

Mitsubishi Electric Building Air Conditioning Control System Transmission Booster PAC-SF46EPA

INSTALLATION MANUAL

- Read this manual thoroughly before using the Transmission Booster.

INSTALLATIONSHANDBUCH

- Lesen Sie dieses Handbuch gründlich durch, bevor Sie die Übertragungsverstärker (Booster).

MANUEL D'INSTALLATION

- Veuillez lire attentivement le présent manuel avant d'utiliser ce module éleveur du niveau des signaux de transmission.

INSTALLATIEHANDLEIDING

- Lees deze handleiding aandachtig door, alvorens de transmissieversterker in gebruik te nemen.

MANUALE DI INSTALLAZIONE

- Prima di utilizzare il booster di trasmissione leggere attentamente il presente manuale.

MANUAL DE INSTALACIÓN

- Lea este manual con detenimiento antes de utilizar el impulsor de transmisión

MANUAL DE INSTALAÇÃO

- Leia atentamente este manual antes de utilizar o Intensificador de Transmissão.

ΕΓΧΕΙΡΙΔΙΟ ΟΔΗΓΙΩΝ ΕΓΚΑΤΑΣΤΑΣΗΣ

- Διαβάστε αυτό το εγχειρίδιο του Πολλαπλασιαστή τάσης μετάδοσης.

РУКОВОДСТВО ПО УСТАНОВКЕ

- Внимательно прочитайте данное руководство перед установкой Усилителя передачи.

MONTAJ ELKİTABI

- İletim güçlendiriciyi kullanmadan önce bu el kitabını dikkatlice okuyun.

安装手册

- 在使用输电升压器前请仔细阅读本手册。

GB

D

F

NL

I

E

P

GR

RU

TR

中文

Contents

1	Safety Precautions	3
2	Product Feature	4
	2-1. Applicable models	4
	2-2. Specification	4
	2-3. Appearance	4
3	Installation	4
	3-1. Parts prepared at site	4
	3-2. Installation space and the direction	5
	3-3. Unit installation	5
4	Wiring	5
	4-1. Wiring procedure	5
	4-2. Power Line	6
	4-3. M-NET transmission line	6
	4-4. Wiring example	7
5	System Limit (length of signal line, maximum number of units)	8

This manual describes the installation of the PAC-SF46EPA Transmission booster. For the information about how to install the centralized controller or the air conditioner units, see the installation manual for them.

For your safety, first be sure to read “1 Safety Precautions” described below thoroughly and then install the PAC-SF46EPA correctly.



After reading this installation manual, keep it in a location that is easy to find, if the PAC-SF46EPA Transmission booster is going to be operated by another person, make sure that this manual is given to him or her.

1 Safety Precautions



- Before installing this unit, make sure you read all the “Safety Precautions”.

The “Safety Precautions” provide very important points regarding safety. Make sure you follow them.

Symbols and Terms

	WARNING: Statements identify condition or practices that could result in personal injury or loss of life.
	CAUTION: Statements identify condition or practices that could result in damage to the unit or other property.

Symbols used in the illustrations

-  : Indicates a part which must be grounded.
-  : Beware of electric shock. (This symbol is displayed on the Transmission booster label.) <Color: Yellow>
-  **ELV** : Please pay attention to electric shock fully because this is not Safety Extra Low-Voltage (SELV) circuit.
And at servicing, please shut down the power supply for the Transmission booster.

	WARNING: Carefully read the labels affixed to the Transmission booster.
---	--

Specific Precautions

 WARNING	
<ul style="list-style-type: none"> ■ Ask your dealer or technical representative to install. Any deficiency caused by your own installation may result in an electric shock or fire. ■ Install in a place which is strong enough to withstand the weight of the unit. Any lack of strength may cause the unit to fall down, resulting in personal injury. ■ Wire and connect using the desired cables securely so that any external force from the cable is imparted to the terminal connections. Imperfect connection and fixing may result in heating or fire. ■ Never modify or repair the unit by yourself. Any deficiency caused by your modification or repair may result in an electric shock or fire. Consult with your distributor for repair. ■ Make sure that the unit is powered by dedicated line. Other appearance connected to the same line could cause an overload. ■ Make sure that there is a main power switch. A ready accessible breaker for power source line helps reduce the risk of electric shocks. Installation of a breaker is mandatory in same areas. 	<ul style="list-style-type: none"> ■ Ensure that installation work is done correctly following this installation manual. Any deficiency caused by installation may result in an electric shock or fire. ■ All electrical work must be performed by a licensed technician, according to local regulations and the instructions given in this manual. Any lack of electric circuit or any deficiency caused by installation may result in an electric shock or fire. ■ Do not move and re-install the unit yourself. Any deficiency caused by installation may result in an electric shock or fire. Ask your distributor or special vendor for moving and installation. ■ This appliance must be earthed. Make sure to install a protective earth(PE)line. Do not connect the protective earth line to gas or water pipes, lighting conductors or telephone grounding lines. Improper grounding may cause an electric shock. ■ The terminal block cover of each line must be firmly attached to prevent entry of dust and moisture. Improper mounting of cover can cause electric shock of fire. ■ Do not dispose of the PAC-SF46EPA by your self.

 CAUTION	
<ul style="list-style-type: none"> ■ Do not install in any place exposed to flammable gas leakage. Flammable gases accumulated around the body of unit may cause an explosion. ■ Do not use in any special environment. Using in any place exposed to oil (including machine oil), steam and sulfuric gas may deteriorate the performances significantly or give damage to the component parts. ■ Wire so that it does not received any tension. Tension may cause wire breakage, heating or fire. ■ Do not wash with water. Doing so may cause an electric shock or a malfunction. ■ Do not install in any place at a temperature of more than 40°C or less than 0°C or exposed to direct sunlight. ■ Use only a fuse of specified capacity. A fuse of large capacity or a steel or copper wire could cause a malfunction or fire. 	<ul style="list-style-type: none"> ■ Do not install in any steamy place such as bathroom or kitchen. Avoid any place where moisture is condensed into dew. Doing so may cause an electric shock or a malfunction. ■ Do not install in any place where acidic or alkaline solution or special spray are often be used. Doing so may cause an electric shock or malfunction. ■ Use standard wires in compliance with the current capacity. A failure to this may result in an electric leakage, heating or fire. ■ Do not touch any PCB (Printed Circuit Board) with your hand or tools. Do not have dust collected on the PCB. Doing so may cause fire or an electric shock. ■ When installing the unit in a hospital, communication station, or similar place, provide sufficient protection against noise. The inverter equipment, private power generator, high-frequency medial equipment, or radio communication equipment may cause the air conditioner to operate erroneously, or fail to operate. On the other hand, the air conditioner may affect such equipment by creating noise that disturbs medial treatment or image broadcasting.

2 Product Feature

2-1. Applicable models

- Super Y Series(PUHY-YSMF-B, PUHY-YSMC)
 - Lossnay unit
 - Centralized controller
- Do not supply power to any other models.

2-2. Specification

Source power requirement	Input voltage	AC220V-AC240V; 0.7A (Maximum loading) 50/60Hz Single-phase	
	Fuse:	2.0A F (IEC127-2)	
Voltage/current of output on the transmission booster side	DC28V-30V 1.7A (Maximum loading)		
Environmental condition	Temperature	Operating	0-40°C (32-104°F)
		Non operating	-20-60°C (-4-104°F)
	Humidity	30-90%RH (No condensation)	
Dimensions	340 (High) × 360 (Width) × 59.2 (Depth) mm		
Weight	3.5 kg (7.8 pounds)		
Installation Environment	Indoor		

2-3. Appearance

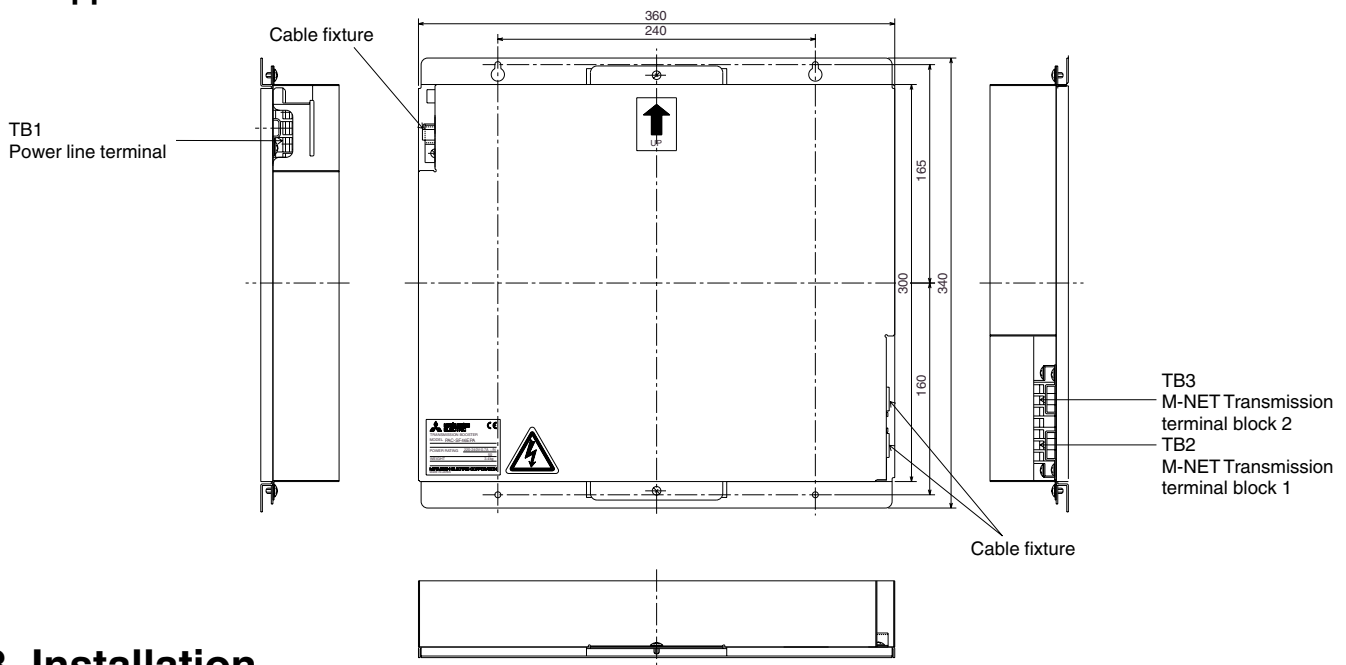

3 Installation

3-1. Parts prepared at site

Please prepare the following parts before installation of the unit.

Preparation parts	Specification
Unit fixing screw	M4 screw × 4pcs
Power cable/ Protective earth cable	<p>Please prepare the power cable complied with your applicable technical standard in consider with power requirement of the unit.</p> <p>*Recommend type; $\phi 1.6\text{mm}$ (2.0 mm²) - $\phi 2.0\text{mm}$ (3.2 mm²) (Example: H03VV-F, H03VVH2-F, H05VV-F, H05VVH2-F)</p> <p>*The sticking by ring crimp terminal for wiring. (Hole diameter: M4)</p> <p>Note: The power supply should comply with local specifications.</p>
Main power switch (Circuit breaker)	<p>Qty.: 1pc</p> <p>Type: 250VAC, Single-phase 50/60Hz, 3A</p> <p>*Recommend type; CP30-BA series(MITSUBISHI ELECTRIC) or equivalent.</p> <p>Note: The power supply should comply with local specifications.</p>
Transmission cable	<p>Type of the cable; Sheathed vinyl cords or cable which comply with the following specifications or equivalent.</p> <ul style="list-style-type: none"> • CPEVS $\phi 1.2\text{mm}$ - $\phi 1.6\text{mm}$ • CVVS 1.25mm² - 2mm² <p>*CPEV; PE insulated PVC jacketed shielded communication cable</p> <p>*CVVS; PVC insulated PVC jacketed shielded control cable</p> <p>*The sticking by ring crimp terminal for wiring. (Hole diameter: M3)</p>

3-2. Installation space and the direction

PAC-SF46EPA Transmission booster is not waterproof type. Therefore this unit shall be installed in a control panel box or the like. Please prepare the control panel box in consider with installation space as shown in the Fig.3-1.

The unit shall be also installed in vertical direction only indicated by the arrow making on the cover as shown in the Fig.3-1.

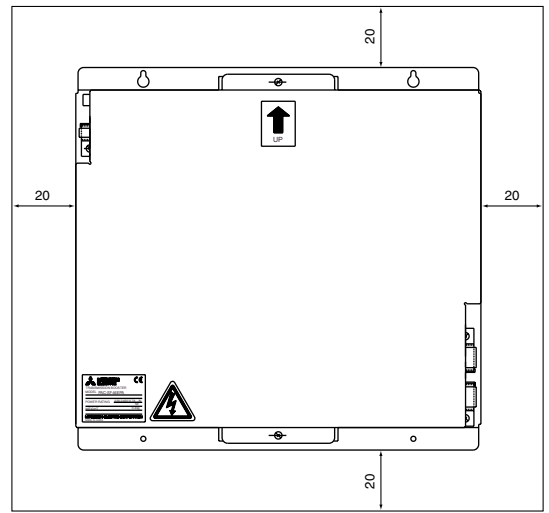

Fig.3-1

3-3. Unit installation

Fix the unit to the control panel box using M4 screw as shown in the Fig.3-2.

CAUTION:

- The unit should be fixed with 4 positions to prevent from unit falling down.
- Install the booster in a location which can withstand a load of 3.5 kg.
- Position the unit, making sure not to drop it.

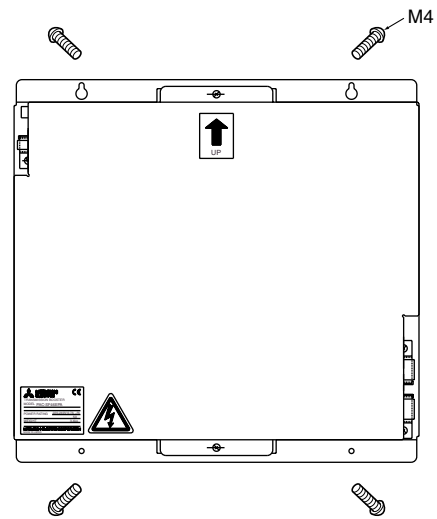

Fig.3-2

4 Wiring

WARNING:

- All electric work must be performed according to local regulations. Improper electrical work may result in electric shock or fire.
- Be sure to shut off the power source of the unit and the all other unit to be connected to the transmission booster before wiring.
- Firmly secure the wiring so that it does not become disconnected.

CAUTION:

- Never connect the power source to the M-NET transmission line, as this will cause a unit failure.

4-1. Wiring procedure

1. Remove the screws used to secure the cover, and then open the cover.

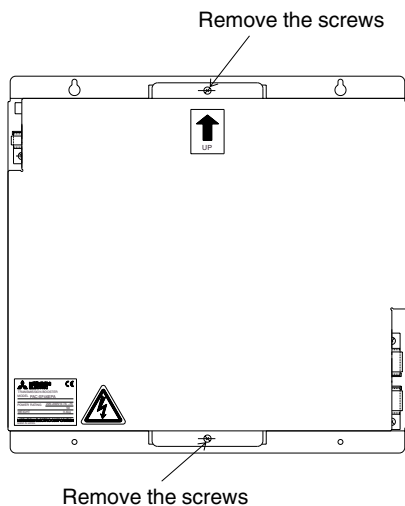

Fig.4-1

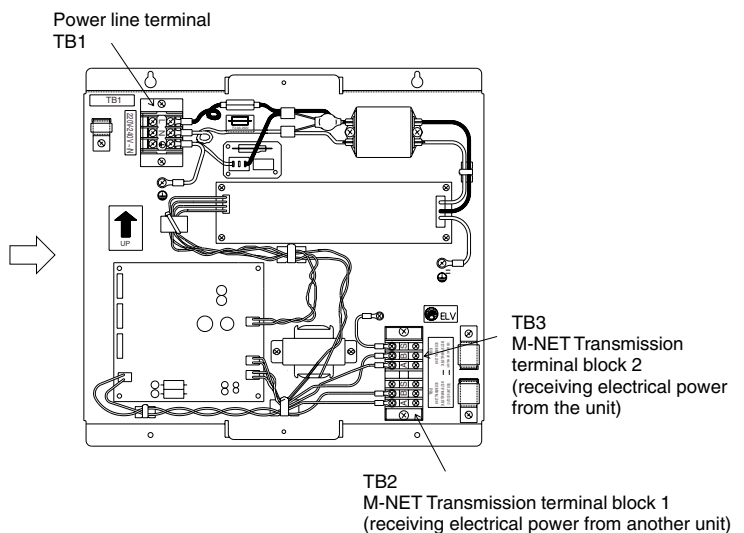

Fig.4-2

2. Connect the power supply and transmission wiring. (Refer to 4-2 and 4-3.)
3. After connection for the each cable, fasten the each cable with the cable fixture.
4. After finishing the wiring, be sure to secure the cover with the screws before turning on the power source.

4-2. Power Line

Wire the power cable and protective earth cable to L, N and the earth line terminals on the TB1 as shown in the Fig.4-3.

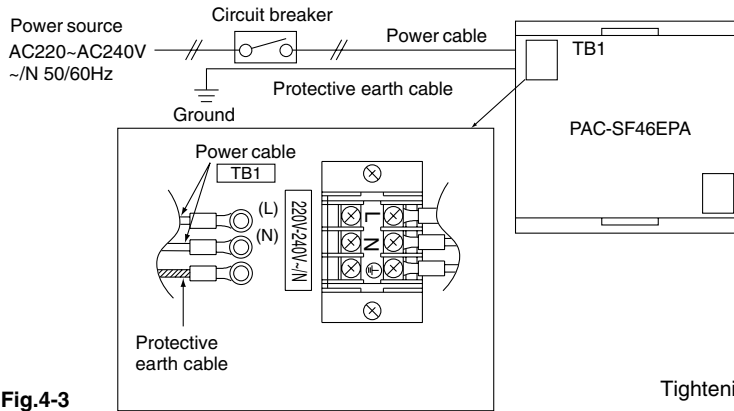

Fig.4-3

Tightening torque: 1.4-2.0 Nm

4-3. M-NET transmission line

Wire the M-NET transmission cable to A, B(non-polarity data) and S(shield) terminals on the TB2 and TB3 as shown in the Fig.4-4.

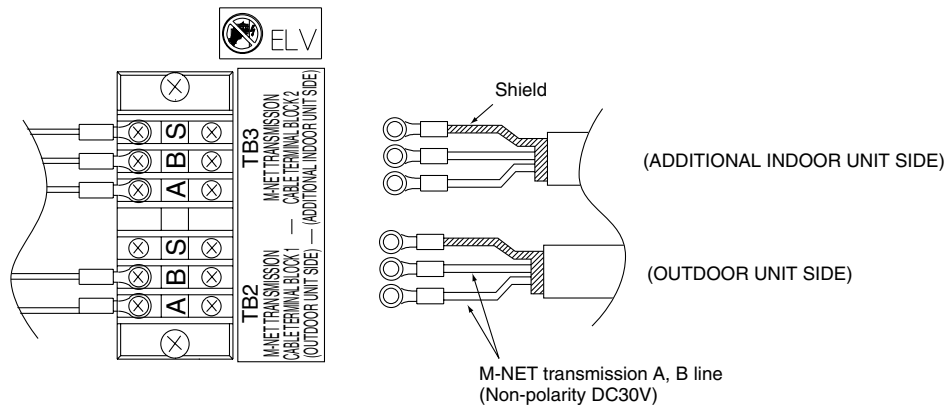

Fig.4-4

Tightening torque: 0.6-1.0 Nm

NOTES:

- The shield wire of M-NET transmission line shall be grounded by one point earthing method.
- The shield wire shall be connected to the S terminal of the only one unit on the common transmission line.

CAUTION:

- Do not mistake transmission line terminal block 1 (TB2) and transmission line terminal block 2 (TB3) when performing the wiring. The transmission booster will not operate correctly if the terminal blocks are connected in reverse.
- Since the M-NET transmission line is 30V DC, do not mistake it with the power line when performing the wiring. (The machine will be broken if the power line is connected to TB2 or TB3.)
- In order to prevent erroneous operations, do not store the power line and M-NET transmission line banded together or in the same conduit.
- Connect the ground wire certainty.
(If the ground wire is not correctly connected, there is a danger of electric shocks or incorrect operations due to the influence of the noise.)
- Never use a megohm tester on the transmission line terminal blocks (TB2 and TB3).

4-4. Wiring example

Example

<Super Y series> For details, refer to the installation manual for the Super Y Series unit.

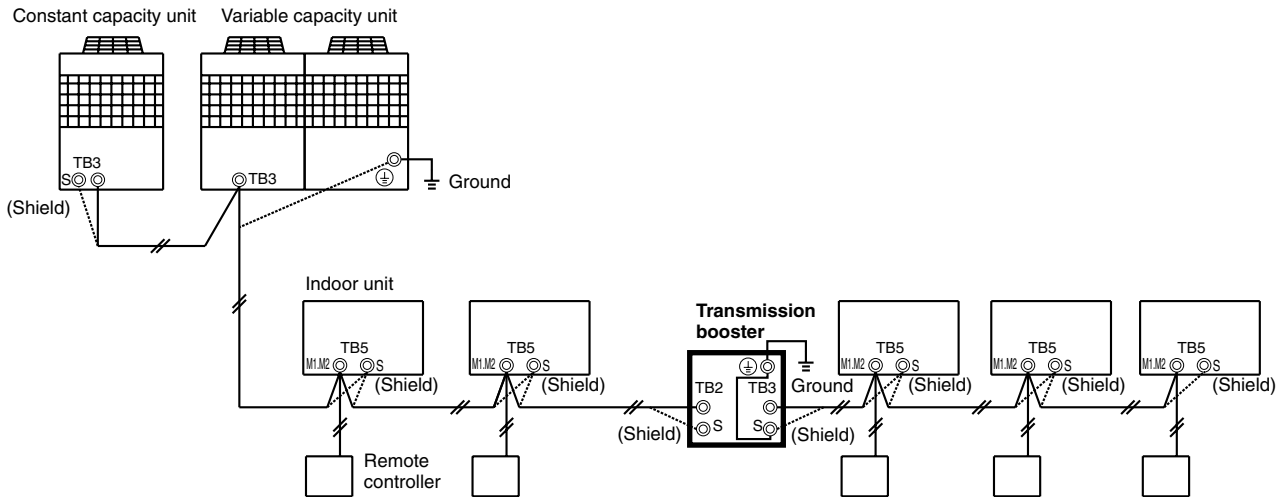

<Centralized controller and Lossnay units>

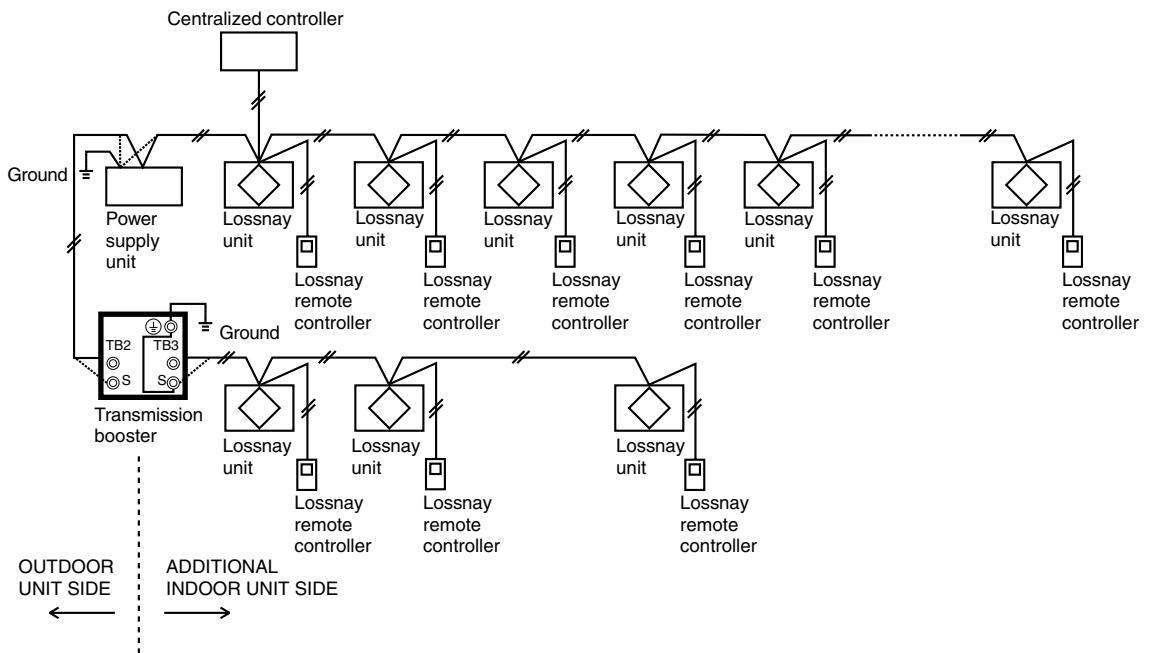

NOTES: *This unit cannot be used to extend the transmission line.

5 System Limit (length of signal line, maximum number of units)

<Super Y series>

Please read the installation manual which is included with the Super Y Series (PUHY-YSMF-B, PUHY-YSMC) unit.

<Except for Super Y series>

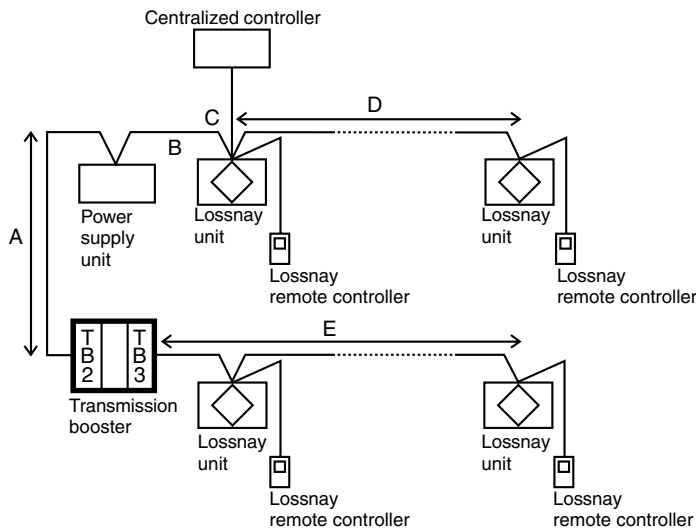

Transmission line length limits

(1) Maximum distance between ends should be less than 500 m

Ex.) $A+B+D+E$,
 $A+B+C+E$,
 $C+D$

(2) Maximum distance from power supply should be less than 200 m

Ex.) $B+D$, $B+C$, A , E

NOTES:

- If the total length of the remote controller's wiring is less than 10 m, use 0.75 mm² cable, and do not add their lengths to the length calculations made above.
- If the total length of the remote controller's wiring is more than 10 m, use 1.25 mm² cable or ø1.2 mm or more shielded cable for the length of wiring exceeding 10 m, and be sure to add their lengths to the length calculations made above.

Maximum number of units that can be connected (TB3 side)

Maximum number of units that can be connected	50 Lossnay remote controllers (One centralized controller is equivalent to 4 Lossnay remote controllers.)
---	--

This product is designed and intended for use in the residential,
commercial and light-industrial environment.

The product at hand is
based on the following
EU regulations:

- Low Voltage Directive 73/23/EEC
- Electromagnetic Compatibility Directive 89/
336/EEC