

SERVICE PARTS LIST FOR MITSUBISHI ELECTRIC PACKAGED AIR-CONDITIONERS

Series PQRV-P•YGM-A

For use with the R410A

July 2005

INDEX

PQRV-P200YGM-A

PQRV-P250YGM-A

PQRY-P200YGM-A
 PQRY-P250YGM-A

EXTERNAL PARTS

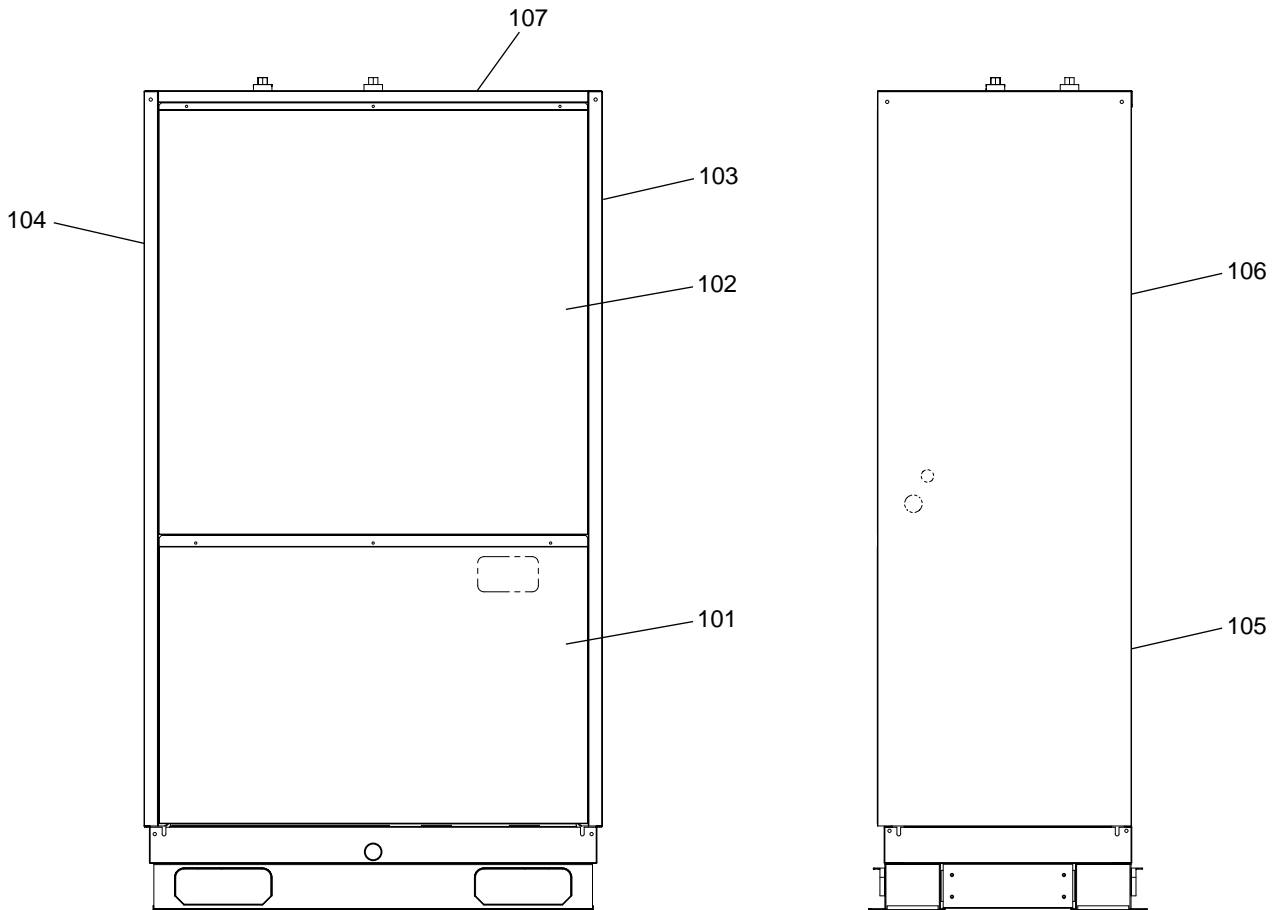

No.	Part No.	Part Name	Spec.	P200YGM-A	P250YGM-A	Dwg. No.	Price
101	R61 4F3 651	Front panel 1 assy		1	1	W660979G01	
102	R61 4F3 652	Front panel 2 assy		1	1	W660980G02	
103	R61 4F3 661	Side panel R assy		1	1	W660977G02	
104	R61 4F3 662	Side panel L assy		1	1	W660978G02	
105	R61 4F3 678	Rear panel 1 assy		1	1	W660981G01	
106	R61 4F3 676	Rear panel 2 assy		1	1	W660982G02	
107	R61 4F3 642	Top panel		1	1	W659887H01	

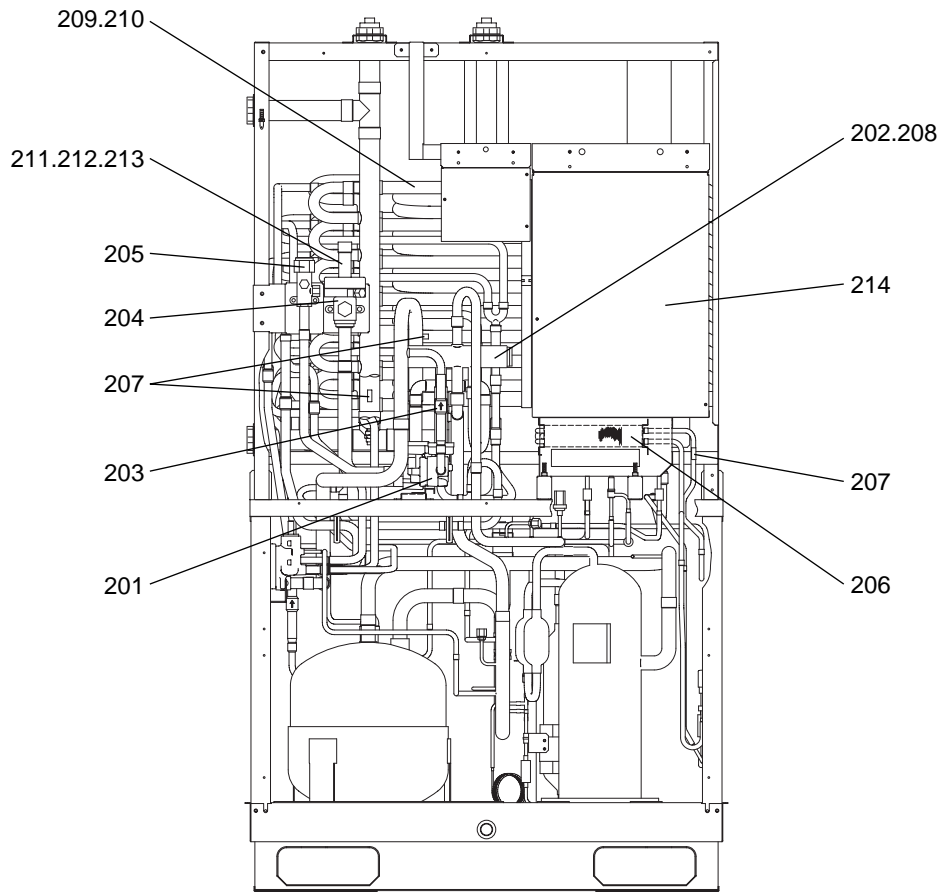

No.	Part No.	Part Name	Spec.			Dwg. No.	Price
				-P200YGM-A	-P250YGM-A		
201	R61 6A7 418	Check valve block assy		1	1	W276816G01	
202	R61 Y05 154	Four way valve	STF-07	1	1	P633119X01	
203	R61 R43 418	Check valve		1	1	P639165X01	
204	R61 R40 410	Ball valve		1	1	P636309X01	
205	R61 R34 410	Ball valve		1	1	P636308X01	
206	R61 4F3 480	Heat exchanger		1	1	W278600G02	
207	R61 670 202	Thermistor	NTH3A14 <TH6,INV,TH9>	3	3	P425496X01	
208	R61 Y16 243	Four way valve coil	<21S4a>	1	1	P472024X01	
209	R61 4F3 481	Heat exchanger assy		1		W277980G04	
210	R61 4F4 481	Heat exchanger assy			1	W277323G04	
211	R61 0G9 441	Pipe assy		1		W663334G01	
212	R61 9F2 441	Pipe assy			1	W663334G02	
213	R61 F14 514	Packing		1	1	P321009X01	
214	R61 Y48 305	Control box	WR-P250	1	1	W278127G01	

PQRY-P200YGM-A
PQRY-P250YGM-A

FUNCTIONAL PARTS (2)

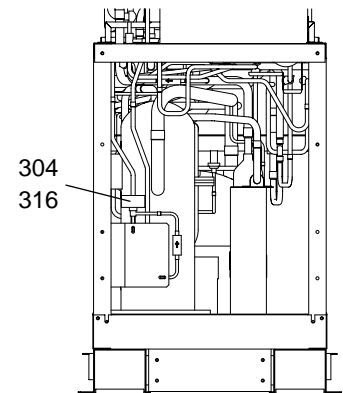
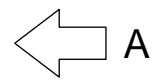
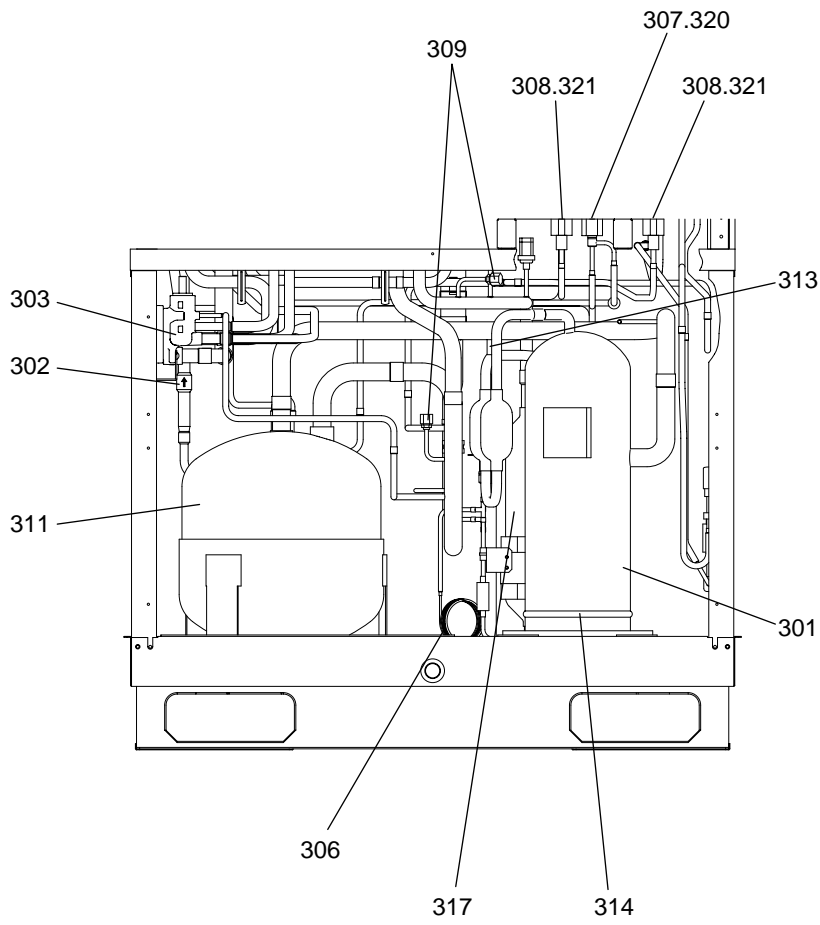
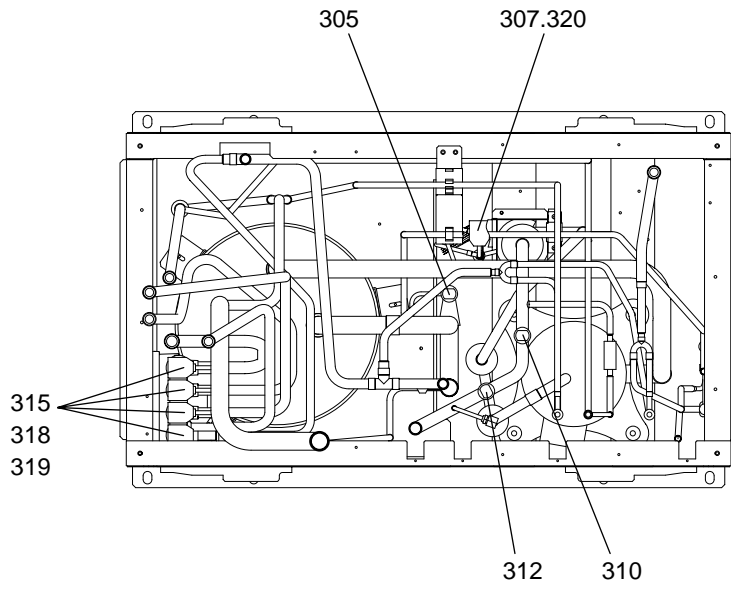

A

PQRY-P200YGM-A
 PQRY-P250YGM-A

CONTROL BOX PARTS

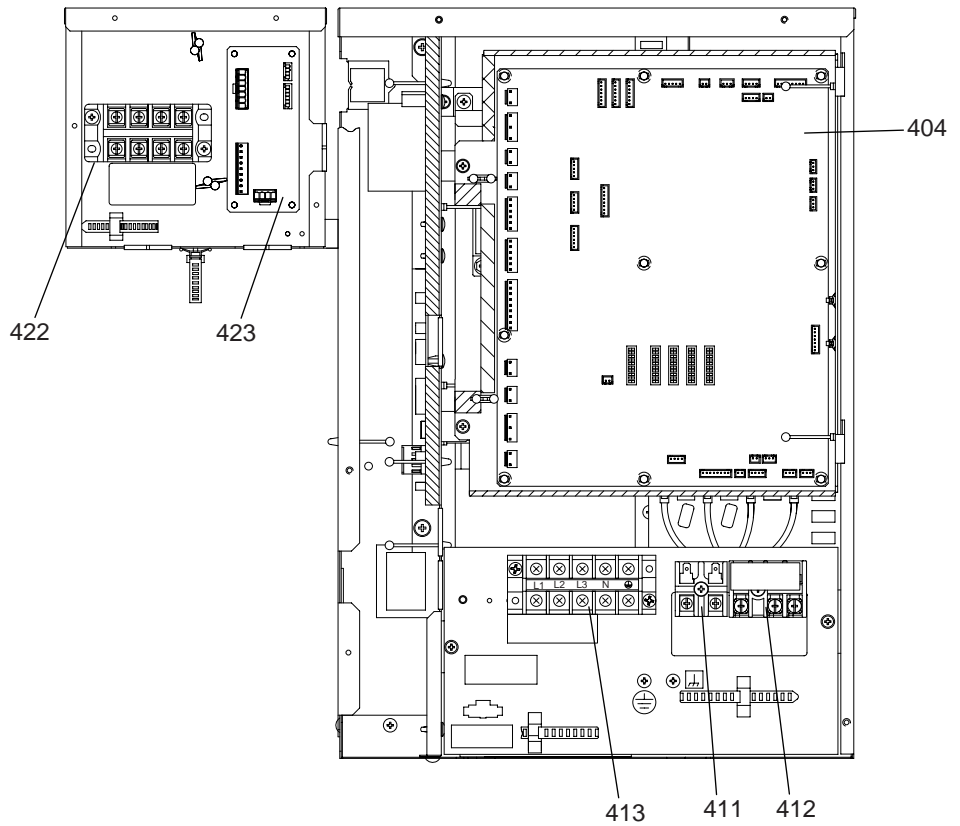
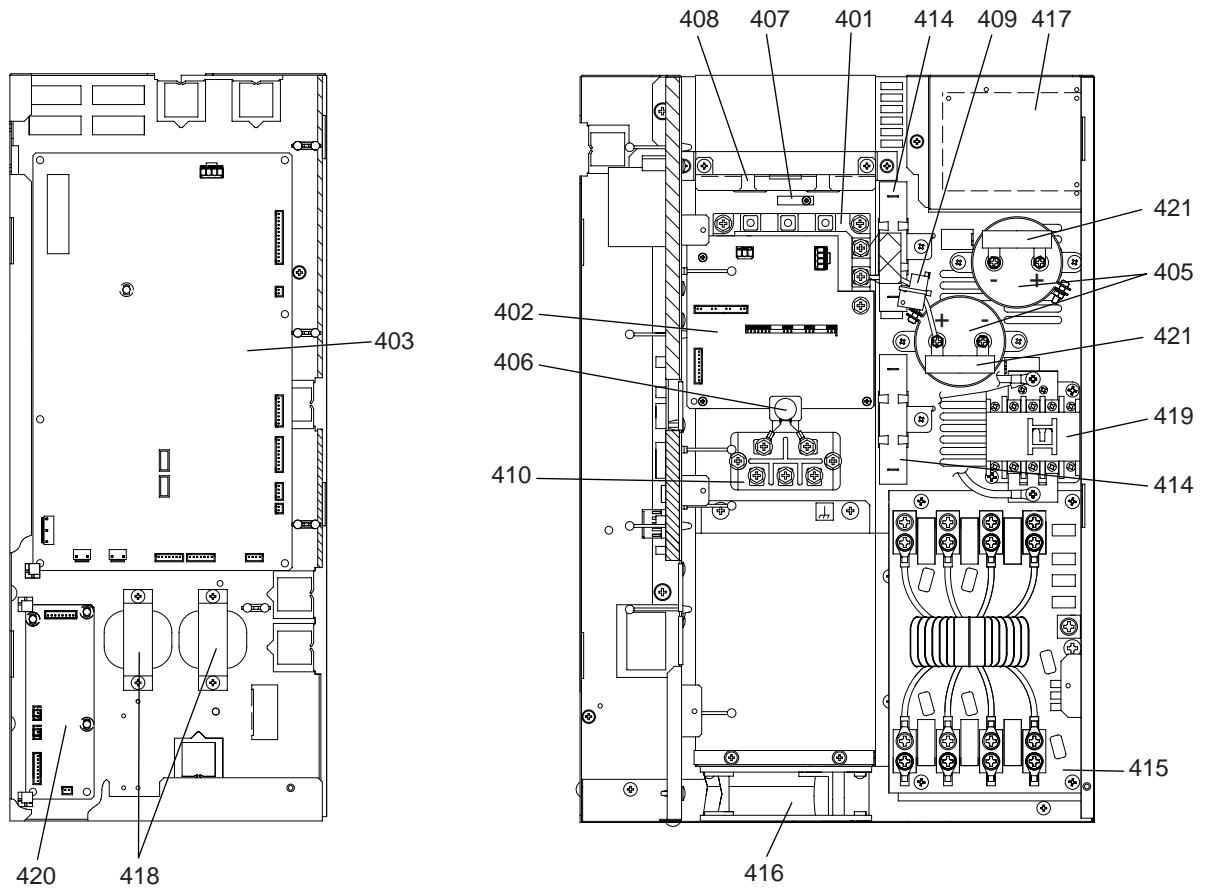

No.	Part No.	Part Name	Spec.	-P200YGM-A	-P250YGM-A	Dwg. No.	Price
401	R61 Y04 249	IPM	6MBP50RA120	1	1	W848413G10	
402	R61 Y43 280	G/A board		1	1	W652112G02	
403	R61 Y25 321	INV board		1	1	W647875G04	
404	R61 Y73 281	Main board		1	1	W647876G27	
405	R61 R34 252	Capacitor	400V 3300μF <C1,C2>	2	2	P412293X01	
406	R61 L85 252	ZNR+C	<ZNR4>	1	1	W886345G01	
407	R61 F14 201	Thermistor	<THHS>	1	1	P414095X01	
408	R61 N79 289	ACCT	CHJ038CP2B<ACCT>	1	1	P418002X01	
409	R61 A42 289	DCCT	<DCCT>	1	1	P419079X02	
410	R61 Y12 320	Diode	DF60LB160 <DS>	1	1	W876941G06	
411	R61 435 246	Terminal bed	<TB3>	1	1	A73S950H02	
412	R61 979 247	Terminal bed	<TB7>	1	1	P436110X01	
413	R61 Y05 246	Terminal bed	<TB1>	1	1	P436151X01	
414	R61 Y06 234	Resistor	40W, 47Ω <R1,R2>	2	2	P411141X01	
415	R61 Y14 293	Noise filter	<ACNF>	1	1	P417015X01	
416	R61 Y02 300	Fan	109S025UL <MF1>	1	1	P712360X01	
417	R61 Y02 259	Reactor	<DCL>	1	1	P715379X01	
418	R61 R40 259	Choke coil	12mH 2A <L1,L2>	2	2	P715392X01	
419	R61 Y28 225	Magnet contactor	PAK-21J, AC240V <52C>	1	1	S427020H12	
420	R61 Y26 321	Filter board		1	1	W629574G06	
421	R61 Y04 234	Resistor	<R3,R4>	2	2	P411124X01	
422	R61 Y07 246	Terminal bed	<TB8>	1	1	P436229X01	
423	R61 Y55 280	Relay board		1	1	W629574G01	

