

TECHNICAL & SERVICE MANUAL

R407C
**Outdoor unit
[Model name]**

PUMY-P125VMA

PUMY-P125YMA

[Service Ref.]
**PUMY-P125VMA
PUMY-P125VMA₁
PUMY-P125YMA
PUMY-P125YMA₁**
Revision :

- PUMY-P125VMA₁ is added in REVISED EDITION-B.
 - "9-8.TEST POINT DIAGRAM" has been added in REVISED EDITION-B.
- Please void OC272 REVISED EDITION-A.

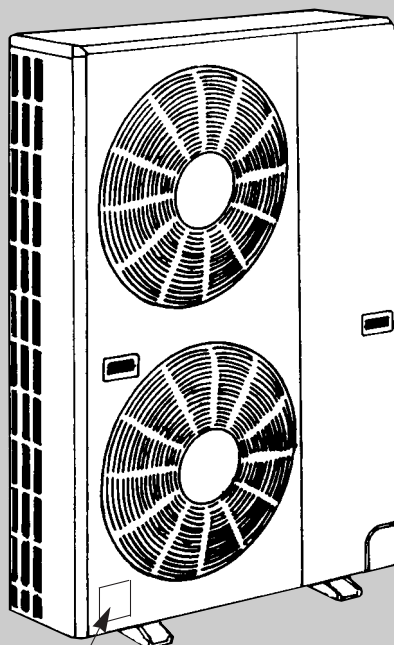
OUTDOOR UNIT

 Model name
indication

CONTENTS

1. TECHNICAL CHANGE	2
2. SAFETY PRECAUTION	3
3. OVERVIEW OF UNITS	5
4. SPECIFICATIONS	8
5. DATA	10
6. OUTLINES AND DIMENSIONS	18
7. WIRING DIAGRAM	19
8. NECESSARY CONDITIONS FOR SYSTEM CONSTRUCTION ...	22
9. TROUBLESHOOTING	34
10. ELECTRICAL WIRING	78
11. REFRIGERANT PIPING TASKS	81
12. DISASSEMBLY	86
13. PARTS LIST	92

OC272 REVISED EDITION-A**PUMY-P125YMA → PUMY-P125YMA₁****1. Addition of new function (Auto Change Over)**

PUMY-P125YMA : Not equipped

PUMY-P125YMA₁ : Equipped

2. Difference of operation switching logic for the outdoor output connector (CN3D)

PUMY-P125YMA : CN3D 1-2 OPEN : Heating CLOSE : Cooling

PUMY-P125YMA₁ : CN3D 1-2 OPEN : Cooling CLOSE : Heating

3. Difference of the role of SW5-1 (function selection switch)

PUMY-P125YMA : Fix the operation frequency ON : Fix OFF : Normal

PUMY-P125YMA₁ : Auto Change Over from Remote Controller ON : Enable OFF : Disable

OC272 REVISED EDITION-B**PUMY-P125VMA → PUMY-P125VMA₁****•Partial Change on Electrical Wiring:**

Change of reactor (DCL).

Only 2 reactor (DCL1,2) are adopted. (Previously 4)

CAUTIONS RELATED TO NEW REFRIGERANT

Cautions for units utilizing refrigerant R407C

Do not use the existing refrigerant piping.

The old refrigerant and lubricant in the existing piping contains a large amount of chlorine which may cause the lubricant deterioration of the new unit.

Use “low residual oil piping”

If there is a large amount of residual oil (hydraulic oil, etc.) inside the piping and joints, deterioration of the lubricant will result.

**Store the piping to be used during installation indoors with keep both ends sealed until just before brazing.
(Store elbows and other joints in a plastic bag.)**

If dust, dirt, or water enters the refrigerant cycle, deterioration of the oil and compressor trouble may result.

Use ESTR , ETHER or HAB as the lubricant to coat flares and flange connection parts.

If large amount of mineral oil enter, that can cause deterioration of refrigerant oil etc.

Use liquid refrigerant to charge the system.

If gas refrigerant is used to seal the system, the composition of the refrigerant in the cylinder will change and performance may drop.

Do not use a refrigerant other than R407C.

If another refrigerant (R22, etc.) is used, the chlorine in the refrigerant may cause the lubricant deterioration.

Use a vacuum pump with a reverse flow check valve.

The vacuum pump oil may flow back into the refrigerant cycle and cause the lubricant deterioration.

Ventilate the room if refrigerant leaks during operation. If refrigerant comes into contact with a flame, poisonous gases will be released.**[1] Cautions for service**

- After recovering the all refrigerant in the unit, proceed to working.
- Do not release refrigerant in the air.
- After completing the repair service, recharge the cycle with the specified amount of liquid refrigerant.

[2] Refrigerant recharging

(1) Refrigerant recharging process

①Direct charging from the cylinder.

- R407C cylinder are available on the market has a syphon pipe.
- Leave the syphon pipe cylinder standing and recharge it.
(By liquid refrigerant)

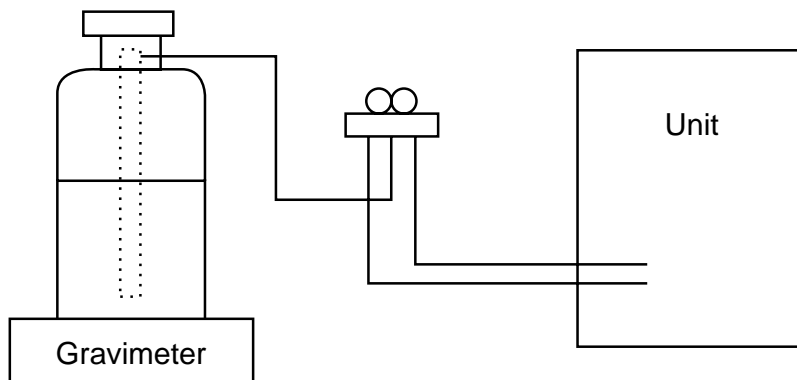

(2) Recharge in refrigerant leakage case

- After recovering the all refrigerant in the unit, proceed to working.
- Do not release the refrigerant in the air.
- After completing the repair service, recharge the cycle with the specified amount of liquid refrigerant.

[3] Service tools

Use the below service tools as exclusive tools for R407C refrigerant.

No.	Tool name	Specifications
①	Gauge manifold	·Only for R407C.
		·Use the existing fitting SPECIFICATIONS. (UNF7/16)
		·Use high-tension side pressure of 3.43MPa-G or over.
②	Charge hose	·Only for R407C.
		·Use pressure performance of 5.10MPa-G or over.
③	Electronic scale	
④	Gas leak detector	·Use the detector for R134a or R407C.
⑤	Adapter for reverse flow check.	·Attach on vacuum pump.
⑥	Refrigerant charge base.	
⑦	Refrigerant cylinder.	·For R407C ·Top of cylinder (Brown)
		·Cylinder with syphon
⑧	Refrigerant recovery equipment.	

3

OVERVIEW OF UNITS

3-1. UNIT CONSTRUCTION

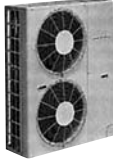
Outdoor unit	5HP	
	PUMY-P125VMA PUMY-P125VMA ₁ PUMY-P125YMA PUMY-P125YMA ₁	
		
Indoor unit that can be connected	Capacity	Type 20~Type 125
	Number of units	1~8 units
	Total system wide capacity	50~130% of outdoor unit capacity

Branching pipe components	CMY-Y62-C-E	CMY-Y64-C	CMY-Y68	CMY-S65
	Branch header (2 branches)	Branch header (4 branches)	Branch header (8 branches)	Multi distribution Piping on outdoor unit (5 branches)

Model Capacity	Cassette Ceiling			Ceiling Concealed PEFY-P	Ceiling mounted built-in PDFY-P	Wall Mounted PKFY-P	Ceiling Suspended PCFY-P	Floor standing	
	4-way flow PLFY-P	2-way flow PLFY-P	1-way flow PMFY-P					Exposed PFFY-P	Concealed PFFY-P
20	-	20VLMD-A	20VBM-A	20VML-A / VMM-A	20VM-A	20VAM-A	-	20VLEM-A	20VLRM-A
25	-	25VLMD-A	25VBM-A	25VML-A / VMM-A	25VM-A	25VAM-A	-	25VLEM-A	25VLRM-A
32	32VKM-A	32VLMD-A	32VBM-A	32VML-A / VMM-A	32VM-A	32VGM-A	-	32VLEM-A	32VLRM-A
40	40VKM-A	40VLMD-A	40VBM-A	40VMH-A / VMM-A	40VM-A	40VGM-A	40VGM-A	40VLEM-A	40VLRM-A
50	50VKM-A	50VLMD-A	-	50VMH-A / VMM-A	50VM-A	50VGM-A	-	50VLEM-A	50VLRM-A
63	63VKM-A	63VLMD-A	-	63VMH-A / VMM-A	63VM-A	63VFM-A	63VGM-A	63VLEM-A	63VLRM-A
71	-	-	-	71VMH-A / VMM-A	71VM-A	-	-	-	-
80	80VAM-A	80VLMD-A	-	80VMH-A / VMM-A	80VM-A	-	-	-	-
100	100VAM-A	100VLMD-A	-	100VMH-A / VMM-A	100VM-A	100VFM-A	100VGM-A	-	-
125	125VAM-A	125VLMD-A	-	125VMH-A / VMM-A	125VM-A	-	125VGM-A	-	-



Remote controller	Name	M-NET remote controller	MA remote controller
	Model number	PAR-F27MEA-E	PAR-20MAA-E
	Functions	<ul style="list-style-type: none"> A handy remote controller for use in conjunction with the Melans centralized management system. Addresses must be set. 	<ul style="list-style-type: none"> Addresses setting is not necessary. Only the indoor unit for MA remote controller (the end of model name is -A) can be used.

3-2. UNIT SPECIFICATIONS

(1) Outdoor Unit

Service Ref.		PUMY-P125VMA ※ PUMY-P125VMA ₁ PUMY-P125YMA PUMY-P125YMA ₁
Capacity	Cooling (kW)	14.0
	Heating (kW)	16.0
Motor for compressor (kW)		3.5

Cooling / Heating capacity indicates the maximum value at operation under the following condition.

※. Cooling Indoor : D.B. 27°C / W.B. 19.0°C
Outdoor : D.B. 35°C
Heating Indoor : D.B. 20°C
Outdoor : D.B. 7°C / W.B. 6°C

(2) Method for identifying MULTI-S model

■ Indoor unit < When using Model 80 >

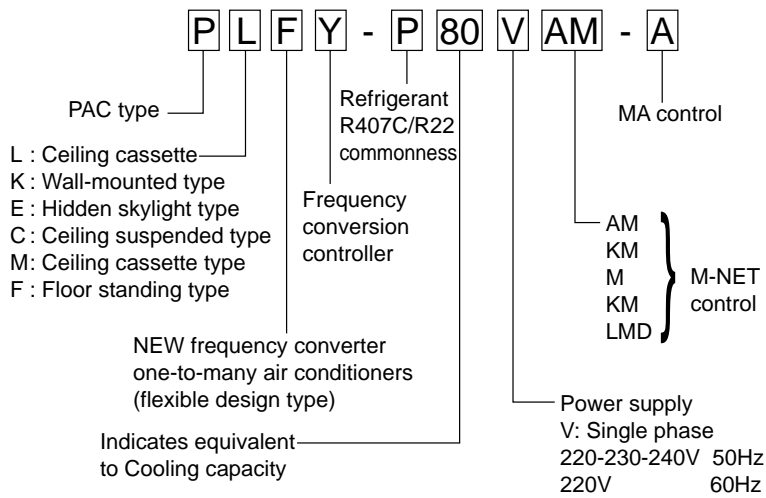

■ Outdoor unit <When using model 125 >

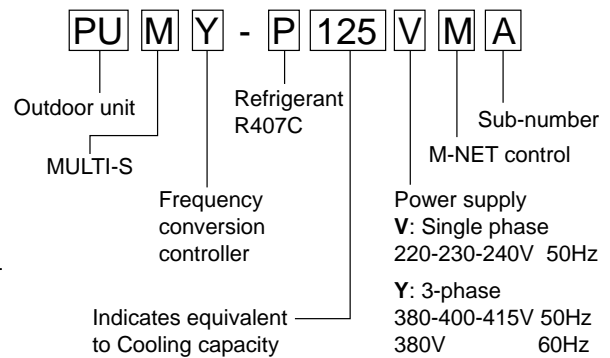

(3) Operating temperature range

	Cooling	Heating
Indoor-side intake air temperature	W.B. 15~24°C	D.B. 15~27°C
Outdoor-side intake air temperature	D.B. -5~46°C	W.B. -15~15.5°C

Notes D.B. : Dry Bulb Temperature
W.B. : Wet Bulb Temperature

3-3. SYSTEM LAYOUT

3-3-1. System layout

One outdoor unit using branching connectors can be connected to a maximum of eight indoor units.

■ Examples of a branching method

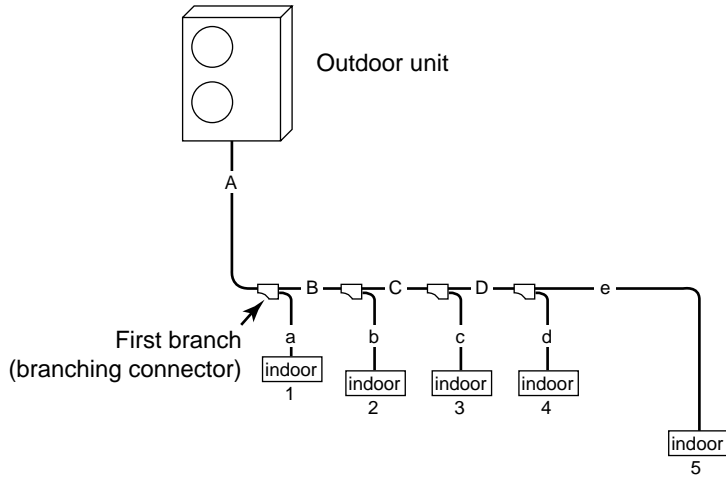

3-3-2. Notes on the connection of indoor and outdoor units

Note: When the total capacity of indoor units exceeds the capacity of the outdoor unit (more than 100%), the rated power of each indoor unit will be less when they are running simultaneously.

Outdoor unit	PUMY-P125VMA PUMY-P125VMA₁ PUMY-P125YMA PUMY-P125YMA₁
Indoor unit that can connected	1~8 units
Available capacity of indoor unit	Type 20 ~ Type 125
Total capacity of units that can be included system (50-130% of outdoor unit capacity)	63~163

3-3-3. Capacity for outdoor unit

(1) Branching pipe

Model		NUMBER OF BRANCHING POINTS
Branching connector	CMY-Y62C-E	2
	CMY-Y64-C	4
	CMY-Y68	8
	CMY-S65	5

(2) Examples of System Construction (All models)

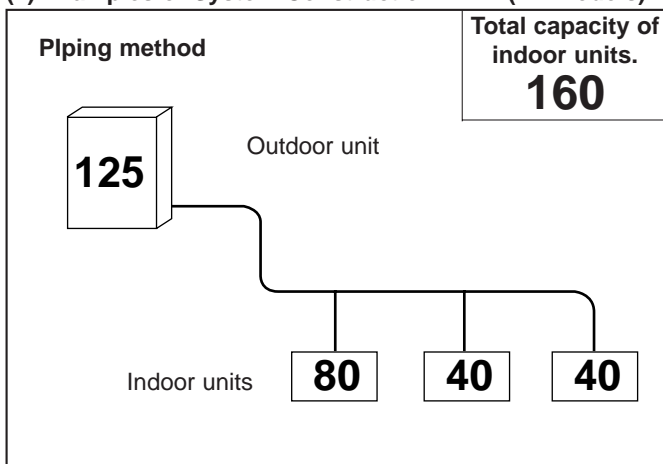

4

SPECIFICATIONS

Item		Service Ref.	Unit	PUMY-P125VMA PUMY-P125VMA ₁
Standard performance	Cooling	Rated Cooling capacity	kW	14.0
		Rated power consumption	kW	6.10
		Operating current	A	28.3-27.1-26.0
		Operating power factor	%	98
		Starting current	A	17
	Heating	Rated Heating capacity	kW	16.0
		Rated power consumption	kW	6.03
		Operating current	A	28.0-26.7-25.7
		Operating power factor	%	98
		Starting current	A	17
Rated power supply				Single phase 220-230-240V 50Hz
External finish (Munsell colour-coded markings)				Molten-galvanized steel plate (with polyester coating), ivory white <5Y 8/1>
Dimensions H × W × D (Note 1)		mm		1280 × 1020 × 350 (+30)
Heat exchanger type				Crossover fin
Compressor	Model			EEV48FAM
	Type × quantity			Fully enclosed type × 1
	Starting method			Frequency converter start
	Motor output	kW		3.5
	Capacity control	%		Cooling 27-100% Heating 25-100%
	Daily cooling capacity	Legal tons		1.9 (104Hz)
	Heater <crankcase>	W		—
	Refrigerating oil (Model)	L		1.4 (MEL32)
Fan	Type × quantity			Propeller (direct) × 2
	Airflow	m ³ /min(CFM)		90(3,177)
	Motor output	W		60 × 2
Defrost method				Reverse cycle
Pressure gauge				—
Protection devices	High pressure protection			High pressure pressure sensor (3.0MPa)
	Compressor protection			Thermal switch
	Blower protection			Thermal switch
	Frequency converter circuit			Overheating, Over current protection
Noise level		dB		54
Weight		kg(lbs)		127(280)
Refrigerant pipe size		Gas	φ mm	19.05
		Liquid	φ mm	9.52
Refrigerant	Type × charge amount		kg	R407C × 8.5
	Control method			Expansion valve

Note 1: External dimensions in parentheses indicate the dimensions of protruding parts.

Note 2: Rating conditions (JIS B 8616)

Cooling : Indoor : D.B. 27°C W.B. 19°C

: Outdoor : D.B. 35°C W.B. 24°C

Heating : Indoor : D.B. 20°C

: Outdoor : D.B. 7°C W.B. 6°C



Item		Service Ref.	Unit	PUMY-P125YMA PUMY-P125YMA ₁
Standard performance	Cooling	Rated Cooling capacity	kW	14.0
		Rated power consumption	kW	5.95
		Operating current	A	9.6-9.1-8.8
		Operating power factor	%	94
		Starting current	A	8.0
	Heating	Rated Heating capacity	kW	16.0
		Rated power consumption	kW	5.58
		Operating current	A	9.2-8.8-8.5
		Operating power factor	%	92
		Starting current	A	8.0
Rated power supply				3 phase 380-400-415V 50Hz
External finish (Munsell colour-coded markings)				Molten-galvanized steel plate (with polyester coating), ivory white <5Y 8/1>
Dimensions H × W × D (Note 1)		mm		1280 × 1020 × 350 (+30)
Heat exchanger type				Crossover fin
Compressor	Model			EEV48FAK
	Type × quantity			Fully enclosed type × 1
	Starting method			Frequency converter start
	Motor output		kW	3.5
	Capacity control		%	Cooling 27-100% Heating 25-100%
	Daily cooling capacity		Legal tons	1.9 (104Hz)
	Heater <crankcase>		W	—
	Refrigerating oil (Model)		L	1.4 (MEL32)
Fan	Type × quantity			Propeller (direct) × 2
	Airflow		m ³ /min(CFM)	90(3,177)
	Motor output		W	60 × 2
Defrost method				Reverse cycle
Pressure gauge				—
Protection devices	High pressure protection			High pressure pressure sensor (3.0MPa)
	Compressor protection			Thermal switch
	Blower protection			Thermal switch
	Frequency converter circuit			Overheating, Over current protection
Noise level		dB		54
Weight		kg(lbs)		127(280)
Refrigerant pipe size		Gas	φ mm	19.05
		Liquid	φ mm	9.52
Refrigerant	Type × charge amount		kg	R407C × 8.5
	Control method			Expansion valve

Note 1: External dimensions in parentheses indicate the dimensions of protruding parts.

Note 2: Rating conditions (JIS B 8616)

Cooling : Indoor : D.B. 27°C W.B. 19°C

: Outdoor : D.B. 35°C W.B. 24°C

Heating : Indoor : D.B. 20°C

: Outdoor : D.B. 7°C W.B. 6°C

5-1. COOLING AND HEATING CAPACITY AND CHARACTERISTICS

5-1-1. Method for obtaining system cooling and heating capacity:

To obtain the system cooling and heating capacity and the electrical characteristics of the outdoor unit, first add up the ratings of all the indoor units connected to the outdoor unit (see table below), and then use this total to find the standard capacity with the help of the tables on page 11 to 14.

(1) Capacity of indoor unit

Model Number for indoor unit	Model 20	Model 25	Model 32	Model 40	Model 50	Model 63	Model 71	Model 80	Model 100	Model 125
Model Capacity	22	28	36	45	56	71	80	90	112	140

(2) Sample calculation

① System assembled from indoor and outdoor unit (in this example the total capacity of the indoor units is greater than that of the outdoor unit)

- Outdoor unit PUMY-P125YMA
- Indoor unit PKFY-P25VAM-A × 2 , PLFY-P50VLMD-A × 2

② According to the conditions in ①, the total capacity of the indoor unit will be: $28 \times 2 + 56 \times 2 = 168$

③ The following figures are obtained from the 168 total capacity row of the standard capacity table (page 12):

Capacity (kW)		Outdoor unit power consumption (kW)		Outdoor unit current (A)	
Cooling	Heating	Cooling	Heating	Cooling	Heating
Ⓐ 14.60	Ⓑ 16.33	6.04	5.14	8.9	7.8

5-1-2. Method for obtaining the heating and cooling capacity of an indoor unit:

(1) The capacity of each indoor unit (kW) = the capacity Ⓐ (or Ⓑ) × $\frac{\text{model capacity}}{\text{total model capacity of all indoor units}}$

(2) Sample calculation (using the system described above in 5-1-1. (2)):

During cooling:

- The total model capacity of the indoor unit is:
 $2.8 \times 2 + 5.6 \times 2 = 16.8 \text{ kW}$
 Therefore, the capacity of PKFY-P25VAM-A and PLFY-P50VLMD-A will be calculated as follows by using the formula in 4-1-2. (1):

$$\text{Model 25} = 14.6 \times \frac{2.8}{16.8} = 2.43 \text{ kW}$$

$$\text{Model 50} = 14.6 \times \frac{5.6}{16.8} = 4.87 \text{ kW}$$

During heating:

- The total model capacity of indoor unit is:
 $3.2 \times 2 + 6.3 \times 2 = 19.0$
 Therefore, the capacity of PKFY-P25VAM-A and PLFY-P50VLMD-A will be calculated as follows by using the formula in 4-1-2. (1):

$$\text{Model 25} = 16.33 \times \frac{3.2}{19.0} = 2.75 \text{ kW}$$

$$\text{Model 50} = 16.33 \times \frac{6.3}{19.0} = 5.41 \text{ kW}$$

5-2. STANDARD CAPACITY DIAGRAM

5-2-1. PUMY-P125VMA, PUMY-P125VMA₁ STANDARD CAPACITY DIAGRAM

* Before calculating the sum of total capacity of indoor units, please convert the valve into the kW model capacity following the formula on page 10.

240V, 50Hz

* Total capacity of indoor units	Capacity (kW)		Power consumption (kW)		Current (A)	
	Cooling	Heating	Cooling	Heating	Cooling	Heating
70	7.00	7.88	2.58	2.86	11.0	12.2
71	7.10	8.00	2.61	2.89	11.1	12.3
72	7.20	8.11	2.65	2.93	11.3	12.5
73	7.30	8.22	2.69	2.97	11.5	12.6
74	7.40	8.33	2.73	3.01	11.6	12.8
75	7.50	8.44	2.76	3.04	11.8	13.0
76	7.60	8.56	2.80	3.08	11.9	13.1
77	7.70	8.67	2.84	3.12	12.1	13.3
78	7.80	8.78	2.88	3.16	12.3	13.5
79	7.90	8.89	2.92	3.20	12.4	13.6
80	8.00	9.00	2.96	3.23	12.6	13.8
81	8.10	9.10	3.00	3.27	12.8	13.9
82	8.20	9.20	3.04	3.31	12.9	14.1
83	8.30	9.30	3.08	3.35	13.1	14.3
84	8.40	9.40	3.12	3.39	13.3	14.5
85	8.50	9.50	3.16	3.43	13.5	14.6
86	8.60	9.60	3.20	3.47	13.6	14.8
87	8.70	9.70	3.25	3.51	13.8	15.0
88	8.80	9.80	3.29	3.55	14.0	15.1
89	8.90	9.90	3.33	3.59	14.2	15.3
90	9.00	10.00	3.38	3.64	14.4	15.5
91	9.10	10.10	3.42	3.68	14.6	15.7
92	9.20	10.22	3.47	3.72	14.8	15.8
93	9.30	10.33	3.51	3.76	15.0	16.0
94	9.40	10.45	3.56	3.80	15.1	16.2
95	9.50	10.56	3.60	3.85	15.3	16.4
96	9.60	10.67	3.65	3.89	15.5	16.6
97	9.70	10.79	3.69	3.93	15.7	16.8
98	9.80	10.90	3.74	3.98	15.9	16.9
99	9.90	11.02	3.79	4.02	16.1	17.1
100	10.00	11.13	3.84	4.06	16.3	17.3
101	10.10	11.24	3.89	4.11	16.6	17.5
102	10.20	11.36	3.93	4.15	16.8	17.7
103	10.30	11.47	3.98	4.20	17.0	17.9
104	10.40	11.59	4.03	4.24	17.2	18.1
105	10.50	11.70	4.08	4.29	17.4	18.3
106	10.60	11.81	4.13	4.33	17.6	18.5
107	10.70	11.93	4.19	4.38	17.8	18.6
108	10.80	12.04	4.24	4.42	18.0	18.8
109	10.90	12.16	4.29	4.47	18.3	19.0
110	11.00	12.27	4.34	4.52	18.5	19.2
111	11.10	12.38	4.39	4.56	18.7	19.4
112	11.20	12.50	4.45	4.61	18.9	19.6
113	11.30	12.63	4.50	4.66	19.2	19.8
114	11.40	12.75	4.55	4.70	19.4	20.0
115	11.50	12.88	4.61	4.75	19.6	20.2
116	11.60	13.00	4.66	4.80	19.9	20.4
117	11.70	13.13	4.72	4.85	20.1	20.7
118	11.80	13.25	4.77	4.90	20.3	20.9
119	11.90	13.38	4.83	4.94	20.6	21.1
120	12.00	13.50	4.89	4.99	20.8	21.3
121	12.10	13.63	4.94	5.04	21.1	21.5
122	12.20	13.75	5.00	5.09	21.3	21.7
123	12.30	13.88	5.06	5.14	21.5	21.9
124	12.40	14.00	5.12	5.19	21.8	22.1
125	12.50	14.13	5.17	5.24	22.0	22.3

5-2-2. PUMY-P125VMA, PUMY-P125VMA₁ STANDARD CAPACITY DIAGRAM

* Before calculating the sum of total capacity of indoor units, please convert the valve into the kW model capacity following the formula on page 10.

240V, 50Hzw

* Total capacity of indoor units	Capacity (kW)		Power consumption (kW)		Current (A)	
	Cooling	Heating	Cooling	Heating	Cooling	Heating
126	12.60	14.25	5.23	5.29	22.3	22.6
127	12.70	14.38	5.29	5.34	22.5	22.8
128	12.80	14.50	5.35	5.39	22.8	23.0
129	12.90	14.63	5.41	5.45	23.1	23.2
130	13.00	14.75	5.47	5.50	23.3	23.4
131	13.10	14.88	5.53	5.55	23.6	23.6
132	13.20	15.00	5.59	5.60	23.8	23.9
133	13.30	15.13	5.66	5.65	24.1	24.1
134	13.40	15.25	5.72	5.71	24.4	24.3
135	13.50	15.38	5.78	5.76	24.6	24.5
136	13.60	15.50	5.84	5.81	24.9	24.8
137	13.70	15.63	5.91	5.87	25.2	25.0
138	13.80	15.75	5.97	5.92	25.4	25.2
139	13.90	15.88	6.04	5.97	25.7	25.4
140	14.00	16.00	6.10	6.03	26.0	25.7
141	14.02	16.01	6.11	6.02	26.0	25.6
142	14.04	16.02	6.11	6.00	26.0	25.6
143	14.06	16.03	6.11	5.98	26.0	25.5
144	14.08	16.04	6.12	5.96	26.1	25.4
145	14.10	16.06	6.12	5.95	26.1	25.3
146	14.12	16.07	6.12	5.93	26.1	25.3
147	14.15	16.08	6.13	5.91	26.1	25.2
148	14.17	16.09	6.13	5.90	26.1	25.1
149	14.19	16.10	6.13	5.88	26.1	25.0
150	14.21	16.12	6.14	5.86	26.1	25.0
151	14.23	16.13	6.14	5.85	26.2	24.9
152	14.25	16.14	6.14	5.83	26.2	24.8
153	14.27	16.15	6.15	5.81	26.2	24.8
154	14.30	16.16	6.15	5.79	26.2	24.7
155	14.32	16.17	6.15	5.78	26.2	24.6
156	14.34	16.19	6.15	5.76	26.2	24.5
157	14.36	16.20	6.16	5.74	26.2	24.5
158	14.38	16.21	6.16	5.73	26.2	24.4
159	14.40	16.22	6.16	5.71	26.3	24.3
160	14.42	16.23	6.17	5.69	26.3	24.3
161	14.45	16.25	6.17	5.68	26.3	24.2
162	14.47	16.26	6.17	5.66	26.3	24.1
163	14.49	16.27	6.18	5.64	26.3	24.0
164	14.51	16.28	6.18	5.62	26.3	24.0
165	14.53	16.29	6.18	5.61	26.3	23.9
166	14.55	16.31	6.19	5.59	26.4	23.8
167	14.57	16.32	6.19	5.57	26.4	23.7
168	14.60	16.33	6.19	5.56	26.4	23.7
169	14.62	16.34	6.20	5.54	26.4	23.6
170	14.64	16.35	6.20	5.52	26.4	23.5
171	14.66	16.36	6.20	5.51	26.4	23.5
172	14.68	16.38	6.21	5.49	26.4	23.4
173	14.70	16.39	6.21	5.47	26.5	23.3
174	14.72	16.40	6.21	5.46	26.5	23.2
175	14.75	16.41	6.22	5.44	26.5	23.2
176	14.77	16.42	6.22	5.42	26.5	23.1
177	14.79	16.44	6.22	5.40	26.5	23.0
178	14.81	16.45	6.22	5.39	26.5	23.0
179	14.83	16.46	6.23	5.37	26.5	22.9
180	14.85	16.47	6.23	5.35	26.5	22.8
181	14.87	16.48	6.23	5.34	26.6	22.7
182	14.89	16.50	6.24	5.32	26.6	22.7

5-2-3. PUMY-P125YMA, PUMY-P125YMA₁ STANDARD CAPACITY DIAGRAM

* Before calculating the sum of total capacity of indoor units, please convert the valve into the kW model capacity following the formula on page 10.

415V, 50Hz

* Total capacity of indoor units	Capacity (kW)		Power consumption (kW)		Current (A)	
	Cooling	Heating	Cooling	Heating	Cooling	Heating
70	7.00	7.88	2.47	2.63	3.8	4.2
71	7.10	8.00	2.50	2.66	3.9	4.2
72	7.20	8.11	2.54	2.70	3.9	4.3
73	7.30	8.22	2.57	2.73	4.0	4.3
74	7.40	8.33	2.61	2.77	4.0	4.4
75	7.50	8.44	2.64	2.80	4.1	4.4
76	7.60	8.56	2.68	2.84	4.1	4.5
77	7.70	8.67	2.72	2.87	4.2	4.5
78	7.80	8.78	2.76	2.91	4.2	4.5
79	7.90	8.89	2.80	2.94	4.3	4.6
80	8.00	9.00	2.83	2.98	4.3	4.7
81	8.10	9.10	2.87	3.02	4.4	4.7
82	8.20	9.20	2.91	3.05	4.4	4.8
83	8.30	9.30	2.95	3.09	4.5	4.8
84	8.40	9.40	2.99	3.13	4.6	4.9
85	8.50	9.50	3.03	3.16	4.6	4.9
86	8.60	9.60	3.07	3.20	4.7	5.0
87	8.70	9.70	3.12	3.24	4.8	5.1
88	8.80	9.80	3.16	3.27	4.8	5.1
89	8.90	9.90	3.20	3.31	4.9	5.2
90	9.00	10.00	3.24	3.35	5.0	5.2
91	9.10	10.10	3.29	3.39	5.0	5.3
92	9.20	10.22	3.33	3.43	5.1	5.4
93	9.30	10.33	3.37	3.47	5.2	5.4
94	9.40	10.45	3.42	3.51	5.2	5.5
95	9.50	10.56	3.46	3.55	5.2	5.5
96	9.60	10.67	3.51	3.59	5.3	5.5
97	9.70	10.79	3.55	3.62	5.4	5.6
98	9.80	10.90	3.60	3.67	5.4	5.7
99	9.90	11.02	3.65	3.71	5.5	5.7
100	10.00	11.13	3.69	3.75	5.6	5.8
101	10.10	11.24	3.74	3.79	5.7	5.9
102	10.20	11.36	3.79	3.83	5.7	5.9
103	10.30	11.47	3.84	3.87	5.8	6.0
104	10.40	11.59	3.88	3.91	5.9	6.0
105	10.50	11.70	3.93	3.95	5.9	6.1
106	10.60	11.81	3.98	3.99	6.0	6.2
107	10.70	11.93	4.03	4.04	6.1	6.2
108	10.80	12.04	4.08	4.08	6.2	6.3
109	10.90	12.16	4.13	4.12	6.2	6.4
110	11.00	12.27	4.18	4.16	6.3	6.4
111	11.10	12.38	4.24	4.21	6.3	6.4
112	11.20	12.50	4.29	4.25	6.4	6.5
113	11.30	12.63	4.34	4.30	6.5	6.6
114	11.40	12.75	4.39	4.34	6.6	6.6
115	11.50	12.88	4.44	4.38	6.6	6.7
116	11.60	13.00	4.50	4.43	6.7	6.8
117	11.70	13.13	4.55	4.47	6.8	6.8
118	11.80	13.25	4.61	4.52	6.9	6.9
119	11.90	13.38	4.66	4.56	7.0	7.0
120	12.00	13.50	4.72	4.61	7.1	7.0
121	12.10	13.63	4.77	4.65	7.1	7.1
122	12.20	13.75	4.83	4.70	7.2	7.2
123	12.30	13.88	4.88	4.74	7.3	7.2
124	12.40	14.00	4.94	4.79	7.4	7.3
125	12.50	14.13	5.00	4.84	7.5	7.4

5-2-4. PUMY-P125YMA, PUMY-P125YMA₁ STANDARD CAPACITY DIAGRAM

※ Before calculating the sum of total capacity of indoor units, please convert the valve into the kW model capacity following the formula on page 10.

415V, 50Hzw

※ Total capacity of indoor units	Capacity (kW)		Power consumption (kW)		Current (A)	
	Cooling	Heating	Cooling	Heating	Cooling	Heating
126	12.60	14.25	5.05	4.88	7.6	7.5
127	12.70	14.38	5.11	4.93	7.6	7.5
128	12.80	14.50	5.17	4.98	7.7	7.5
129	12.90	14.63	5.23	5.03	7.7	7.6
130	13.00	14.75	5.29	5.07	7.8	7.7
131	13.10	14.88	5.35	5.12	7.9	7.7
132	13.20	15.00	5.41	5.17	8.0	7.8
133	13.30	15.13	5.47	5.22	8.1	7.9
134	13.40	15.25	5.53	5.27	8.2	8.0
135	13.50	15.38	5.59	5.32	8.3	8.0
136	13.60	15.50	5.65	5.36	8.4	8.1
137	13.70	15.63	5.71	5.41	8.5	8.2
138	13.80	15.75	5.77	5.46	8.5	8.3
139	13.90	15.88	5.84	5.51	8.6	8.3
140	14.00	16.00	5.95	5.58	8.8	8.4
141	14.02	16.01	5.96	5.57	8.8	8.4
142	14.04	16.02	5.96	5.55	8.8	8.4
143	14.06	16.03	5.96	5.53	8.8	8.4
144	14.08	16.04	5.97	5.52	8.8	8.3
145	14.10	16.06	5.97	5.50	8.8	8.3
146	14.12	16.07	5.97	5.49	8.8	8.3
147	14.15	16.08	5.98	5.47	8.9	8.3
148	14.17	16.09	5.98	5.46	8.9	8.3
149	14.19	16.10	5.98	5.44	8.9	8.2
150	14.21	16.12	5.99	5.43	8.9	8.2
151	14.23	16.13	5.99	5.41	8.9	8.2
152	14.25	16.14	5.99	5.39	8.9	8.2
153	14.27	16.15	5.99	5.38	8.9	8.1
154	14.30	16.16	6.00	5.36	8.9	8.1
155	14.32	16.17	6.00	5.35	8.9	8.1
156	14.34	16.19	6.00	5.33	8.9	8.1
157	14.36	16.20	6.01	5.32	8.9	8.0
158	14.38	16.21	6.01	5.30	8.9	8.0
159	14.40	16.22	6.01	5.28	8.9	8.0
160	14.42	16.23	6.02	5.27	8.9	8.0
161	14.45	16.25	6.02	5.25	8.9	7.9
162	14.47	16.26	6.02	5.24	8.9	7.9
163	14.49	16.27	6.03	5.22	8.9	7.9
164	14.51	16.28	6.03	5.21	8.9	7.9
165	14.53	16.29	6.03	5.19	8.9	7.8
166	14.55	16.31	6.03	5.17	8.9	7.8
167	14.57	16.32	6.04	5.16	8.9	7.8
168	14.60	16.33	6.04	5.14	8.9	7.8
169	14.62	16.34	6.04	5.13	8.9	7.8
170	14.64	16.35	6.05	5.11	9.0	7.8
171	14.66	16.36	6.05	5.10	9.0	7.8
172	14.68	16.38	6.05	5.08	9.0	7.8
173	14.70	16.39	6.06	5.06	9.0	7.7
174	14.72	16.40	6.06	5.05	9.0	7.7
175	14.75	16.41	6.06	5.03	9.0	7.7
176	14.77	16.42	6.07	5.02	9.0	7.7
177	14.79	16.44	6.07	5.00	9.0	7.6
178	14.81	16.45	6.07	4.99	9.0	7.6
179	14.83	16.46	6.07	4.97	9.0	7.6
180	14.85	16.47	6.08	4.95	9.0	7.6
181	14.87	16.48	6.08	4.94	9.0	7.6
182	14.89	16.50	6.08	4.92	9.0	7.5

5-3. CORRECTING COOLING AND HEATING CAPACITY

5-3-1. Correcting Changes in Air Conditions

(1) The performance curve charts (Figure 1, 2) show the rated capacity (total capacity) under the stated conditions when standard length for piping (5m) is used. The rated power is derived from the capacity ratio and power ratio obtained for the indoor and outdoor intake temperatures at time 1.

- Standard conditions:

Service Ref.	PUMY-P125VMA	PUMY-P125VMA ₁	PUMY-P125YMA	PUMY-P125YMA ₁
Rated cooling capacity	Indoor D.B. 27°C / W.B. 19°C Outdoor D.B. 35°C			
Rated heating capacity	Indoor D.B. 20°C Outdoor D.B. 7°C / W.B. 6°C			

- Use the rated capacity and rated power values given in the characteristics table for each indoor unit.
- The capacity is the single value on the side of the outdoor unit; the capacity on the sides of each indoor unit must be added to obtain the total capacity.

(2) The capacity of each indoor unit may be obtained by multiplying the total capacity obtained in (1) by the ratio between the individual capacity at the rated time and the total capacity at the rated time.

$$\text{Individual capacity under stated conditions} = \text{total capacity under the stated conditions} \times \frac{\text{individual capacity at the rated time}}{\text{total capacity at the rated time}}$$

(3) Capacity correction factor curve

**Figure 1. PUMY-P125VMA PUMY-P125YMA
PUMY-P125VMA₁ PUMY-P125YMA₁
Cooling performance curve**

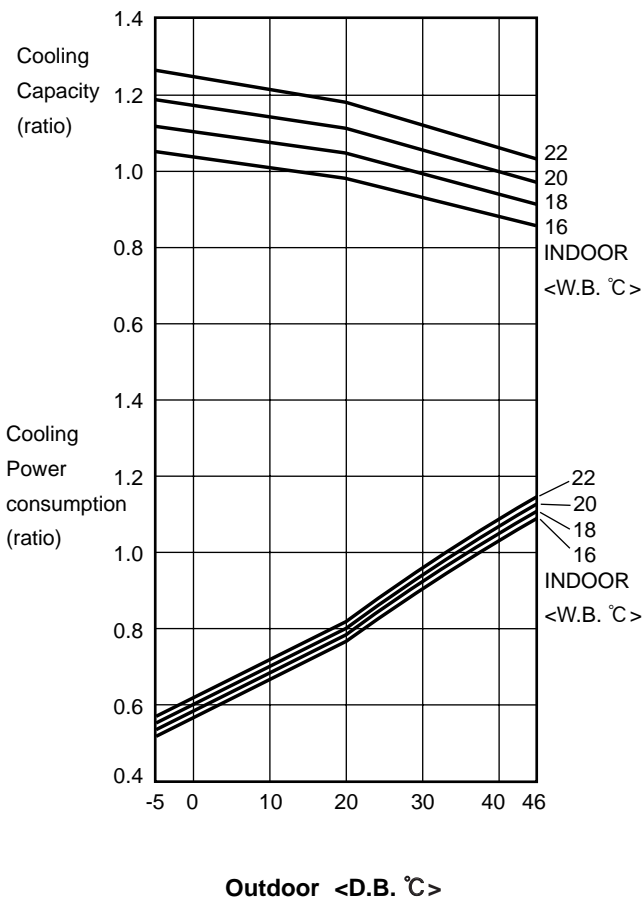

**Figure 2. PUMY-P125VMA PUMY-P125YMA
PUMY-P125VMA₁ PUMY-P125YMA₁
Heating performance curve**

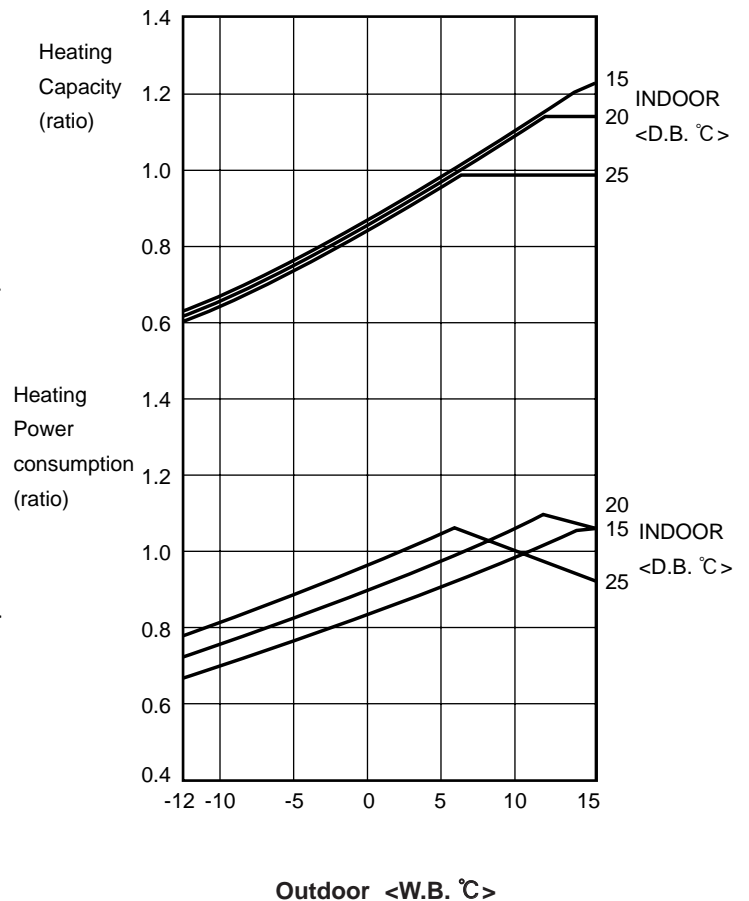

5-3-2. Correcting Capacity for Changes in the Length of Refrigerant Piping

- (1) During cooling, to obtain the ratio (and the equivalent piping length) of the outdoor units rated capacity and the total in-use indoor capacity, first find the capacity ratio corresponding to the standard piping length (5m) from Figures 3 at first, and then multiply by the cooling capacity from Figure 1 to obtain the actual capacity.
- (2) During heating, to find the equivalent piping length, first find the capacity ratio corresponding to standard piping length (5m) from Figure 4, and then multiply by the heating capacity from Figure 2 to obtain the actual capacity.

(1) Cooling capacity correction factor

Figure 3. PUMY-P125VMA PUMY-P125VMA₁ PUMY-P125YMA PUMY-P125YMA₁
Cooling capacity correction curve

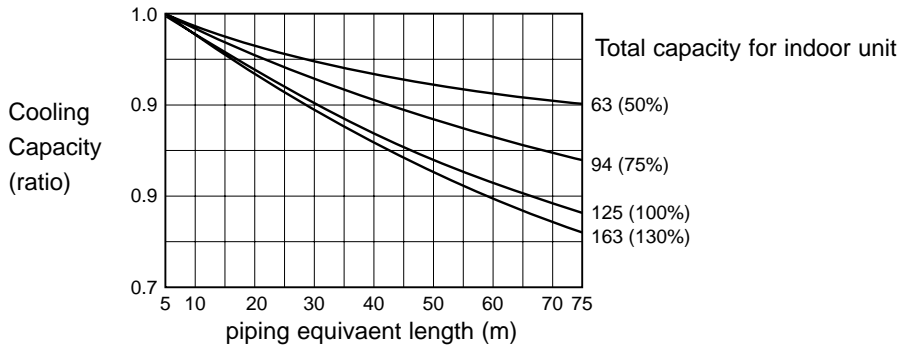

(2) Heating capacity correction factor

Figure 4. PUMY-P125VMA PUMY-P125VMA₁ PUMY-P125YMA PUMY-P125YMA₁
Heating capacity correction curve

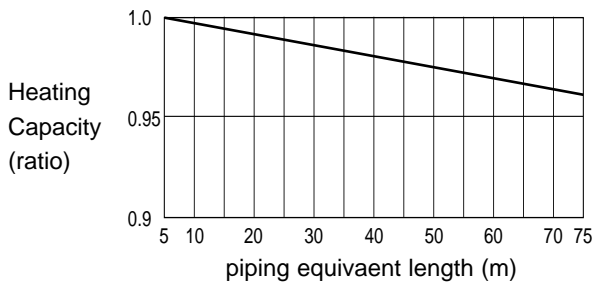

(3) Method for Obtaining the Equivalent Piping Length

Equivalent length for type 125 = (length of piping to farthest indoor unit) + (0.35 × number of bends in the piping) (m)

Length of piping to farthest indoor unit: type 125.....70m

5-3-3. Correction of Heating Capacity for Frost and Defrosting

If heating capacity has been reduced due to frost formation or defrosting, multiply the capacity by the appropriate correction factor from the following table to obtain the actual heating capacity.

Correction factor diagram

Outdoor Intake temperature (W.B.°C)	6	4	2	0	-2	-4	-6	-8	-10
Correction factor	1.0	0.98	0.89	0.88	0.89	0.9	0.95	0.95	0.95

PUMY-P125VMA
PUMY-P125VMA₁
PUMY-P125YMA
PUMY-P125YMA₁

NOTCH	SPL(dB)	LINE
Hi	54	○—○

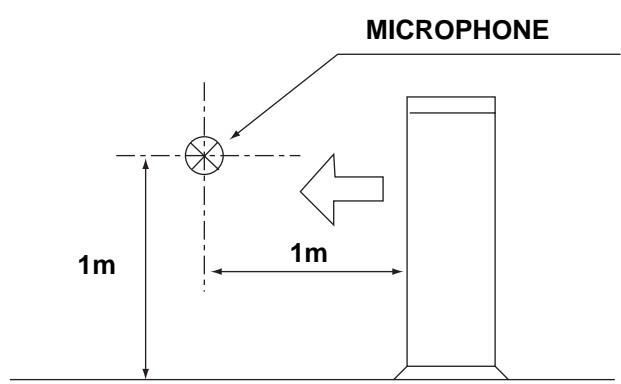
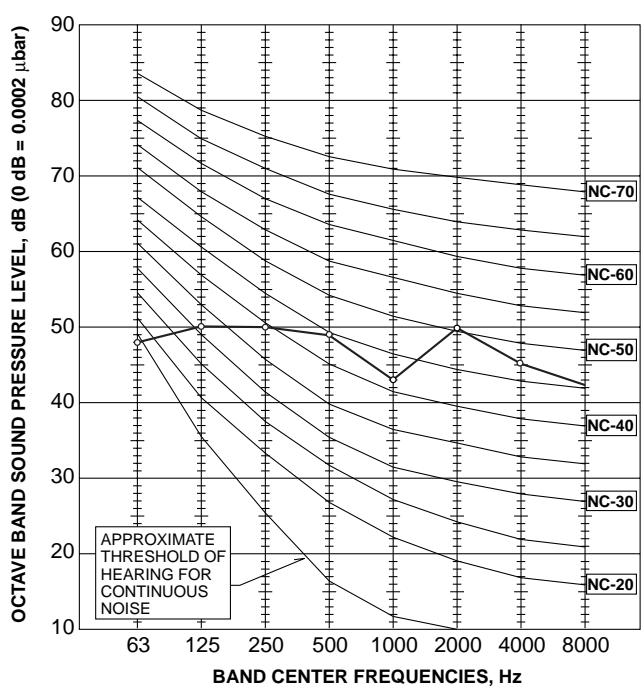

- OUTDOOR UNITS
 PUMY-P125VMA
 PUMY-P125VMA₁
 PUMY-P125YMA
 PUMY-P125YMA₁

unit : mm

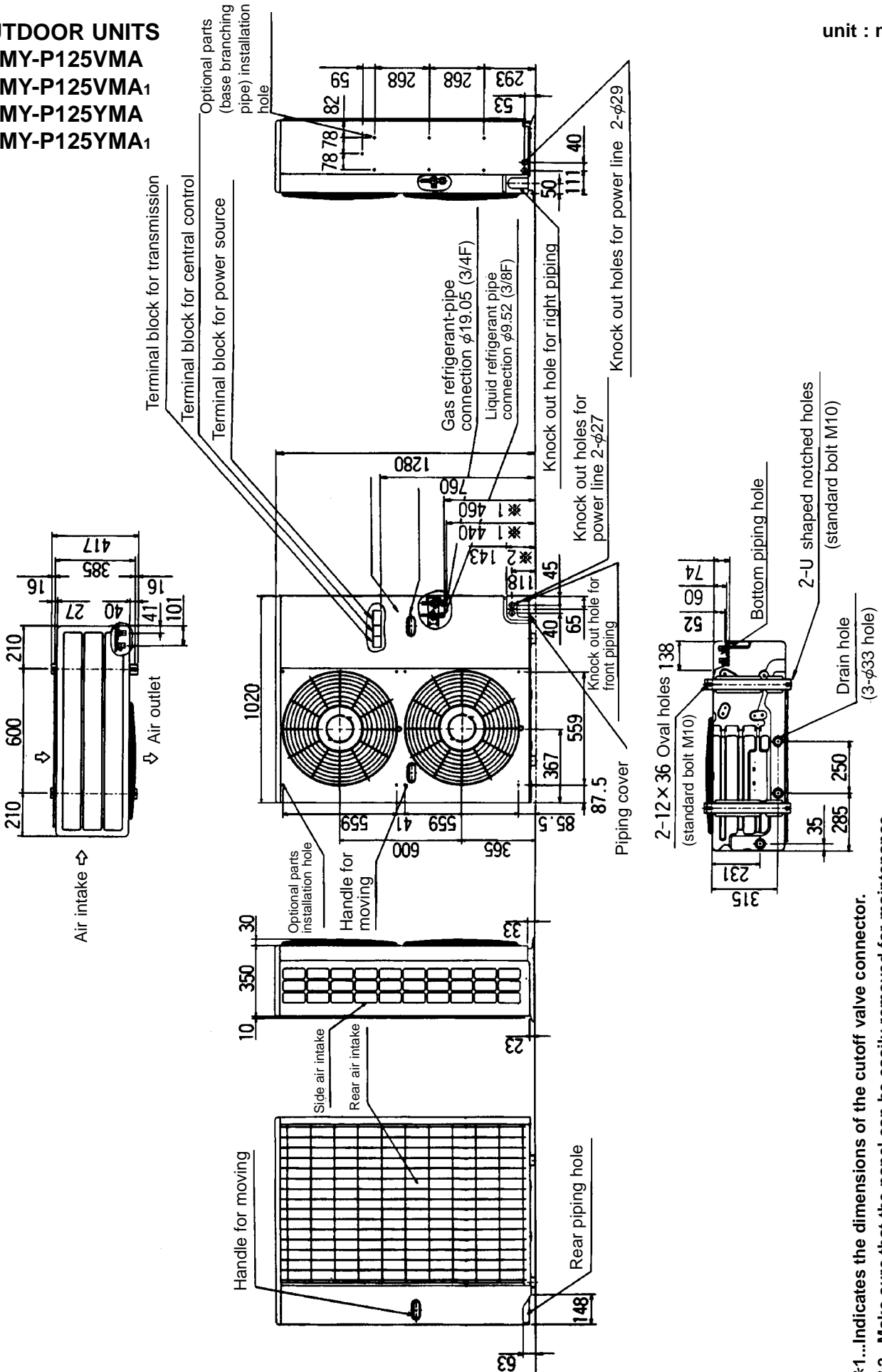

*1...Indicates the dimensions of the cutoff valve connector.
 *2...Make sure that the panel can be easily removed for maintenance when a piping cover is used for aesthetic reasons.

PUMY-P125VMA PUMY-P125VMA1

SYMBOL	NAME	SYMBOL	NAME	SYMBOL	NAME	SYMBOL	NAME
TB1	Terminal Block(Power Supply)	52C	Magnetic Contactor	N.F.	Noise Filter Circuit Board	CNS1	Connector(Multi system)
TB3	Terminal Block(Transmission)	21S4	4-Way Valve	L/L/O	Connection Lead(L-Phase)	CNS2	Connector(Centralized Control)
TB7	Terminal Block(Centralized Control)	SV	Solenoid Valve(Hot Gas Bypass)	N/I/N/O	Connection Lead(N-Phase)	CN4	Connector
CE	Smoothing Capacitor	LEV(A)	Expansion Valve	E1	Connection Terminal(Ground)	CN40	Connector(Centralized Control Power Supply)
C1,C2	Fan Motor Capacitor	MF1,MF2	Fan Motor(Inner Thermostat)	CNAC2	Connector	CN41	Connector(For String Jumper Connector)
DCL1-4	Reactor(PUMY-P125VMA)	MC	Compressor(Inner Thermostat)	CN5	Connector	CN51	Connector(Connected for Option) Compressor drive signal,Error signal
DCL1,2	Reactor(PUMY-P125VMA1)						
RS	Resistor(Rush Current Protection)	P.B.	Power Circuit Board	M.B.	Multi Circuit Board	CN3D	Connector(Connected for Option) Auto Change Over Signal
ACTM	Active Filter Module	U/V/W	Connection Terminal(U/V/W Phase)	F1,F2	Fuse(6.3A)	CN3S	Connector(Connected for Option) Demand Signal
TH1	Thermistor(Discharge Temperature Detection)	CN2-6	Connector	SW1	Switch(Display Selection)		
TH2	Thermistor (Low Pressure Saturated Temp.Detection)	CNDC	Connector	SW2	Switch(Function Selection)		
TH5	Thermistor (Pipe Temp.Detection / Judging Defrost)	CNAF	Connector	SW3	Switch(Test Run)	X500	Relay(Magnetic Contactor)
TH6	Thermistor(Outdoor Temp.Detection)	IGBT	Converter, Inverter	SW4	Switch(Model Selection)	X501	Relay(4-Way Valve)
THHS A/B	Thermistor(Radiator Panel) A:ACTM,B:IGBT	LED1	Light Emitting Diode(Inverter Control Status)	SW5	Switch(Function Selection) SW5-1 Auto Change Over OFF:disabled ON:enabled	X502	Relay(Solenoid Valve)
63HS	High Pressurer Sensor (Discharge Pressure Detection)	SC-S,R	Screw Type Terminal(L./N-Phase)	SW6	Switch(Function Selection)	LED1,2	Digital Indication LED Operation Inspection Indication
49C	Thermal Switch(Compressor)	SC-P1,P2	Screw Type Terminal(DC Voltage)	SWU1	Switch(Unit Address Selection,1st digit)		
		SC-N1,N2	Screw Type Terminal(DC Voltage)	SWU2	Switch(Unit Address Selection,2nd digit)		

*1 The address automatically becomes "100" if it is set as "01~50".

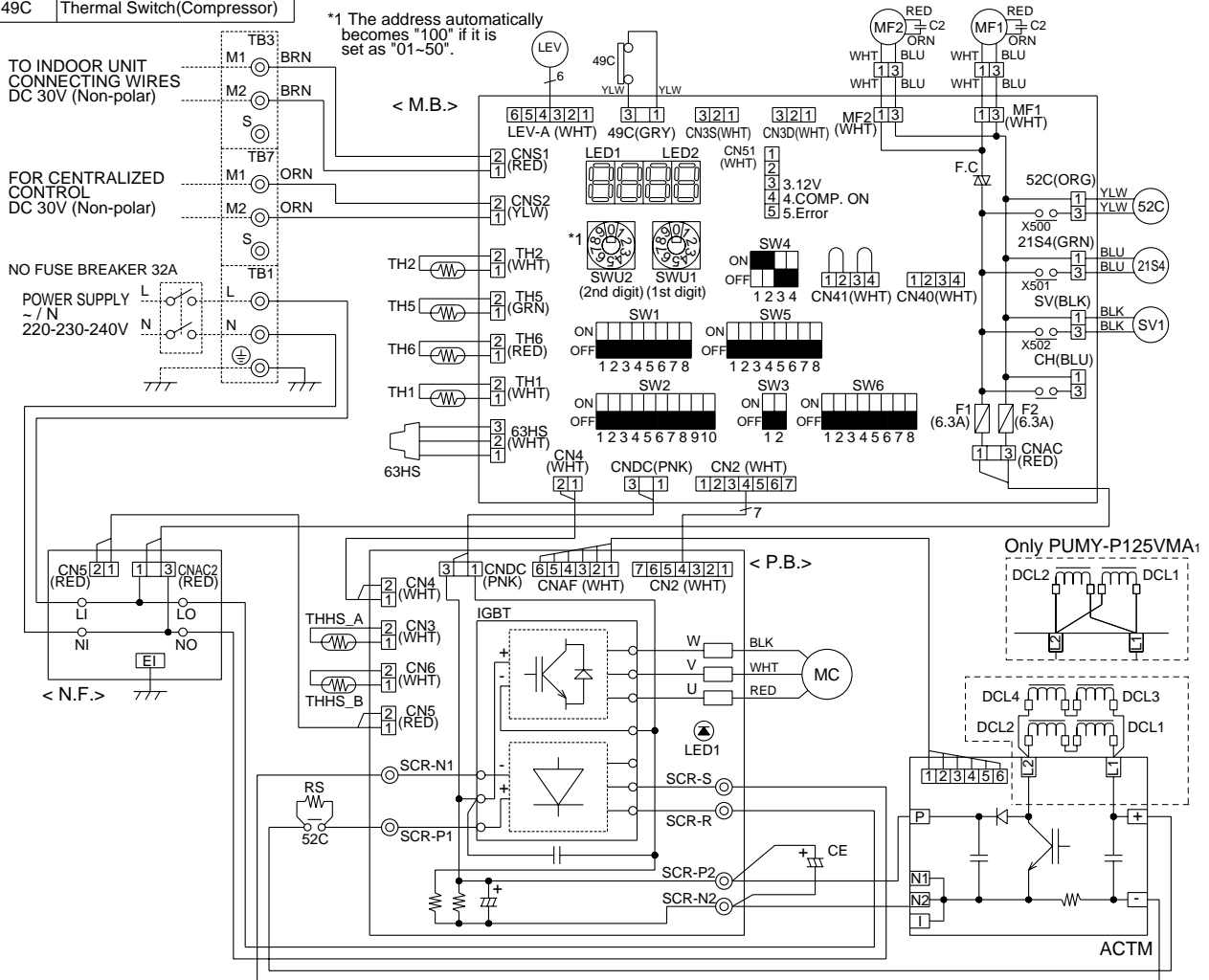

- NOTES: 1. Refer to the wiring diagrams of the indoor units for details on wiring of each indoor unit.
 2. Symbols used in wiring diagram above are. ⊙:Terminal block, □:Connector, ▭:Insertion tab.
 3. Self-diagnosis function
 The indoor and outdoor units can be diagnosed automatically using the self-diagnosis switch(SW1) and LED1,2 (LED indication)found on the multi-controller of the outdoor unit.
 LED indication : Set all contacts of SW1 to OFF.
 4. For the system utilizing R-converter units(PAC-SF29LB),the following functions are not available.
 SW3;TEST RUN SW5-1;AUTO CHANGE OVER CN3D;AUTO CHANGE OVER(external signal)
 5. The input for CN3D 1-2(AUTO CHANGE OVER EXTERNAL SIGNAL)is as follows.
 Short;heating Open;Cooling(It differs from Service ref.PUMY-P125VMA)

•During normal operation
 The LED indicates the drive state of the controller in the outdoor unit.

Bit	1	2	3	4	5	6	7	8
Indication	Compressor operated	52C	21S4	SV1	-	-	-	Always lit

•When fault requiring inspection has occurred

The LED alternately indicates the inspection code and the location of the unit in which the fault has occurred.

(Example)
 When the compressor and SV1 are turned during cooling operation.



PUMY-P125YMA

SYMBOL	NAME	SYMBOL	NAME	SYMBOL	NAME	SYMBOL	NAME
ACCT	CONNECTOR <CURRENT DETECTION>	C1,C2	FAN MOTOR CAPACITOR	SV1	SOLENOID VALVE <HOT GAS BYPASS>	TH2	THERMISTOR <LOW PRESSURE SATURATED TEMPERATURE DETECTION>
CB1,CB2	SMOOTHING CAPACITOR	DM	DIODE MODULE	SW1	SWITCH <DISPLAY SELECTION>	TH5	THERMISTOR <PIPE TEMPERATURE DETECTION • JUDGING DEFROST>
CNA	CONNECTOR <POWER SUPPLY>	DCL	REACTOR	SW2	SWITCH <FUNCTION SELECTION>	TH6	THERMISTOR <OUTDOOR TEMPERATURE DETECTION>
CNR	CONNECTOR <DISCHARGE CIRCUIT, POWER SUPPLY>	F.C	FAN CONTROL	SW3	SWITCH <TEST RUN>		
CNS1	CONNECTOR <MULTI SYSTEM>	FUSE1	FUSE (6.3A)	SW4	SWITCH <MODEL SELECTION>	TH6	THERMISTOR
CNS2	CONNECTOR <CENTRALIZED CONTROL>	FUSE2	FUSE (2A)	SW5	SWITCH <FUNCTION SELECTION>	X	RELAY
CN1	CONNECTOR <CONTROLLER DRIVE CONTROL>	IPM	INTELLIGENT POWER MODULE	SWU1	SWITCH <UNIT ADDRESS SELECTION,1ST DIGIT>	X71	RELAY <MAGNETIC CONTACTOR>
CN2	CONNECTOR <POWER SYNC SIGNAL, PROTECTION>	LD1	DIGITAL INDICATION LED <OPERATION INSPECTION INDICATION>	SWU2	SWITCH <UNIT ADDRESS SELECTION,2ND DIGIT>	X72	RELAY <4-WAY VALVE>
CN3	CONNECTOR <POWER SUPPLY 30V, 12V, 5V>	MC	COMPRESSOR <INNER THERMOSTAT>	SWU3	SWITCH <UNIT ADDRESS SELECTION,3RD DIGIT>	X73	RELAY <SOLENOID VALVE>
CN4	CONNECTOR <INVERTER SIGNAL 5V>	MF1,MF2	FAN MOTOR <INNER THERMOSTAT>	TB1	TERMINAL BLOCK <POWER SUPPLY>	ZNR	VARISTOR
CN40	CONNECTOR <CENTRALIZED CONTROL POWER SUPPLY>	NF	NOISE FILTER	TB3	TERMINAL BLOCK <TRANSMISSION>	21S4	4-WAY VALVE
CN41	CONNECTOR <FOR STORING JUMPER CONNECTOR>	RS1	RESISTOR <RUSH CURRENT PROTECT>	TB7	TERMINAL BLOCK <CENTRALIZED CONTROL>	49C	THERMAL SWITCH <COMPRESSOR>
CN51	CONNECTOR <COMPRESSOR DRIVE SIGNAL OUTPUT>	RB1,RB2	RESISTOR <VOLTAGE BALANCE ADJUSTMENT>	THHS	THERMISTOR <IPM RADIATOR PANEL TEMPERATURE DETECTION>	52C	MAGNETIC CONTACTOR
CN3D	CONNECTOR <AUTO CHANGE OVER SIGNAL>	RD1,RD2	RESISTOR <DISCHARGE>	TH1	THERMISTOR <DISCHARGE TEMPERATURE DETECTION>	63HS	HIGH PRESSURE SENSOR <DISCHARGE PRESSURE DETECTION>
CN3S	CONNECTOR <DEMAND SIGNAL>	SLEV	EXPANSION VALVE				
C01,C02	SMOOTHING CAPACITOR						
C03	CAPACITOR <FILTER>						

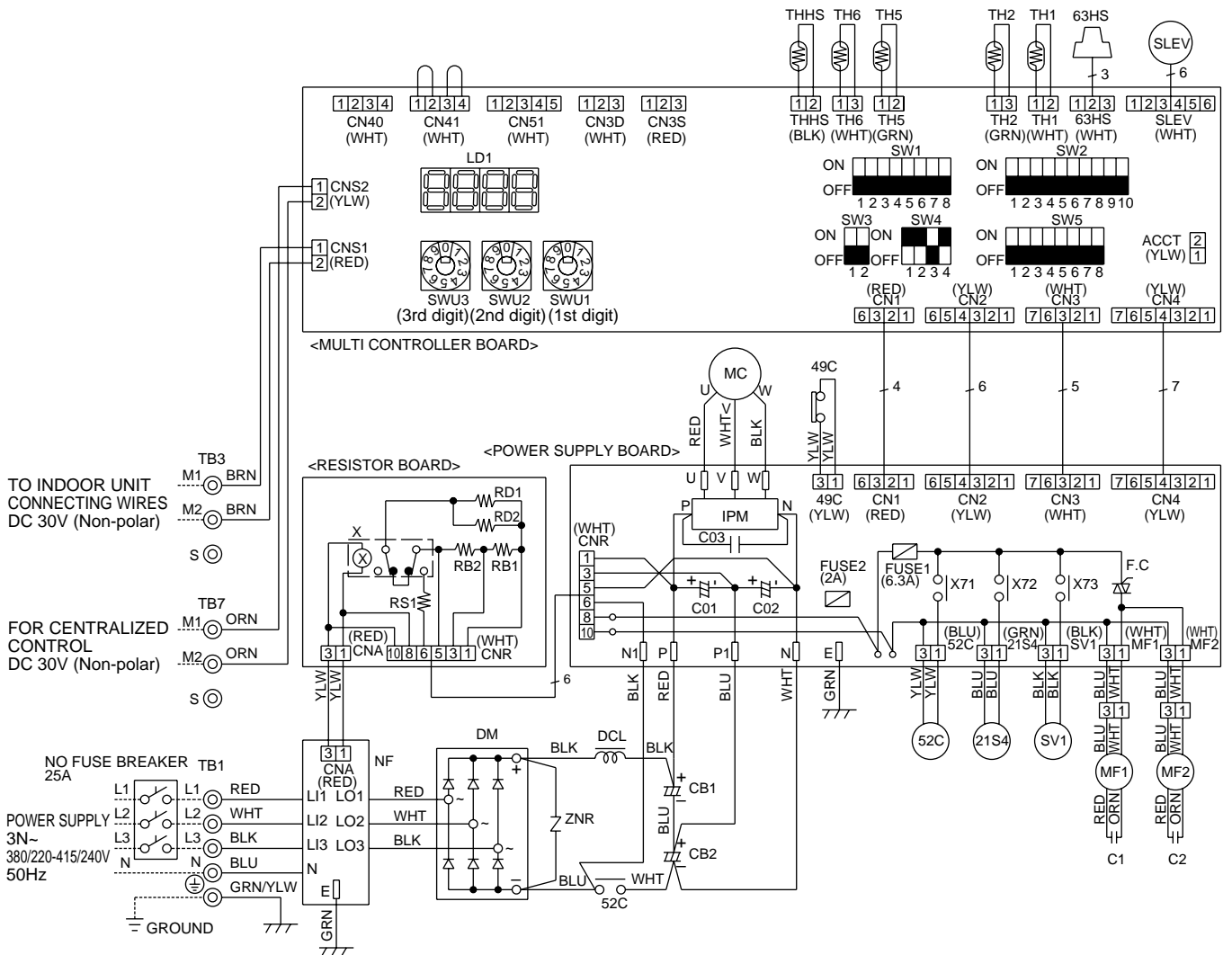

- NOTES : 1. Refer to the wiring diagrams of the indoor units for details on wiring of each indoor unit.
 2. Symbols used in wiring diagram above are. ⊙: Terminal block, □□: Connector, □: Insertion tab.
 3. Self-diagnosis function

The indoor and outdoor units can be diagnosed automatically using the self-diagnosis switch (SW1) and LD1(LED indication) found on the multi-controller of the outdoor unit.
 LED indication : Set all contacts of SW1 to OFF.

•During normal operation

The LED indicates the drive state of the controller in the outdoor unit.

Bit	1	2	3	4	5	6	7	8
Indication	Compressor operated	52C	21S4	SV1	-	-	-	Always lit

•When fault requiring inspection has occurred

The LED alternately indicates the inspection code and the location of the unit in which the fault has occurred.

(Example)
 When the compressor and SV1 are turned during cooling operation.



PUMY-P125YMA₁

SYMBOL	NAME	SYMBOL	NAME	SYMBOL	NAME	SYMBOL	NAME
ACCT	CONNECTOR <CURRENT DETECTION>	C1,C2	FAN MOTOR CAPACITOR	SV1	SOLENOID VALVE <HOT GAS BYPASS>	TH2	THERMISTOR <LOW PRESSURE SATURATED TEMP. DETECTION>
CB1,CB2	SMOOTHING CAPACITOR	DM	DIODE MODULE	SW1	SWITCH <DISPLAY SELECTION>	TH5	THERMISTOR <PIPE TEMP. DETECTION • JUDGING DEFROST>
CNA	CONNECTOR <POWER SUPPLY>	DCL	REACTOR	SW2	SWITCH <FUNCTION SELECTION>	TH6	THERMISTOR <OUTDOOR TEMP. DETECTION>
CNR	CONNECTOR <DISCHARGE CIRCUIT,POWER SUPPLY>	F.C	FAN CONTROL	SW3	SWITCH <TEST RUN>	X	RELAY
CNS1	CONNECTOR <MULTI SYSTEM>	FUSE1	FUSE (6.3A)	SW4	SWITCH <MODEL SELECTION>	X71	RELAY <MAGNETIC CONTACTOR>
CNS2	CONNECTOR <CENTRALIZED CONTROL>	FUSE2	FUSE (2A)	SW5	SWITCH <FUNCTION SELECTION> SW5-1 AUTO CHANGE OVER OFF : disabled ON : enabled	X72	RELAY <4-WAY VALVE>
CN1	CONNECTOR <CONTROLLER DRIVE CONTROL>	IPM	INTELLIGENT POWER MODULE	SWU1	SWITCH <UNIT ADDRESS SELECTION,1ST DIGIT>	X73	RELAY <SOLENOID VALVE>
CN2	CONNECTOR <POWER SYNC SIGNAL,PROTECTION>	LD1	DIGITAL INDICATION LED <OPERATION INSPECTION INDICATION>	SWU2	SWITCH <UNIT ADDRESS SELECTION,2ND DIGIT>	ZNR	VARISTOR
CN3	CONNECTOR <POWER SUPPLY 30V,12V,5V>	MC	COMPRESSOR <INNER THERMOSTAT>	SWU3	SWITCH <UNIT ADDRESS SELECTION,3RD DIGIT>	21S4	4-WAY VALVE
CN4	CONNECTOR <INVERTER SIGNAL 5V>	MF1,MF2	FAN MOTOR <INNER THERMOSTAT>	TB1	TERMINAL BLOCK <POWER SUPPLY>	49C	THERMAL SWITCH <COMPRESSOR>
CN40	CONNECTOR <CENTRALIZED CONTROL POWER SUPPLY>	NF	NOISE FILTER	TB3	TERMINAL BLOCK <TRANSMISSION>	52C	MAGNETIC CONTACTOR
CN41	CONNECTOR <FOR STORING JUMPER CONNECTOR>	RS1	RESISTOR <RUSH CURRENT PROTECT>	TB7	TERMINAL BLOCK <CENTRALIZED CONTROL>	63HS	HIGH PRESSURE SENSOR <DISCHARGE PRESSURE DETECTION>
CN51	CONNECTOR <COMPRESSOR DRIVE SIGNAL OUTPUT>	RB1,RB2	RESISTOR <VOLTAGE BALANCE ADJUSTMENT>	THHS	THERMISTOR <IPM RADIATOR PANEL TEMP. DETECTION>		
CN3D	CONNECTOR <AUTO CHANGE OVER SIGNAL>	RD1,RD2	RESISTOR <DISCHARGE>	TH1	THERMISTOR <DISCHARGE TEMP. DETECTION>		
CN3S	CONNECTOR <DEMAND SIGNAL>	SLEV	EXPANSION VALVE				
C01,C02	SMOOTHING CAPACITOR						
C03	CAPACITOR <FILTER>						

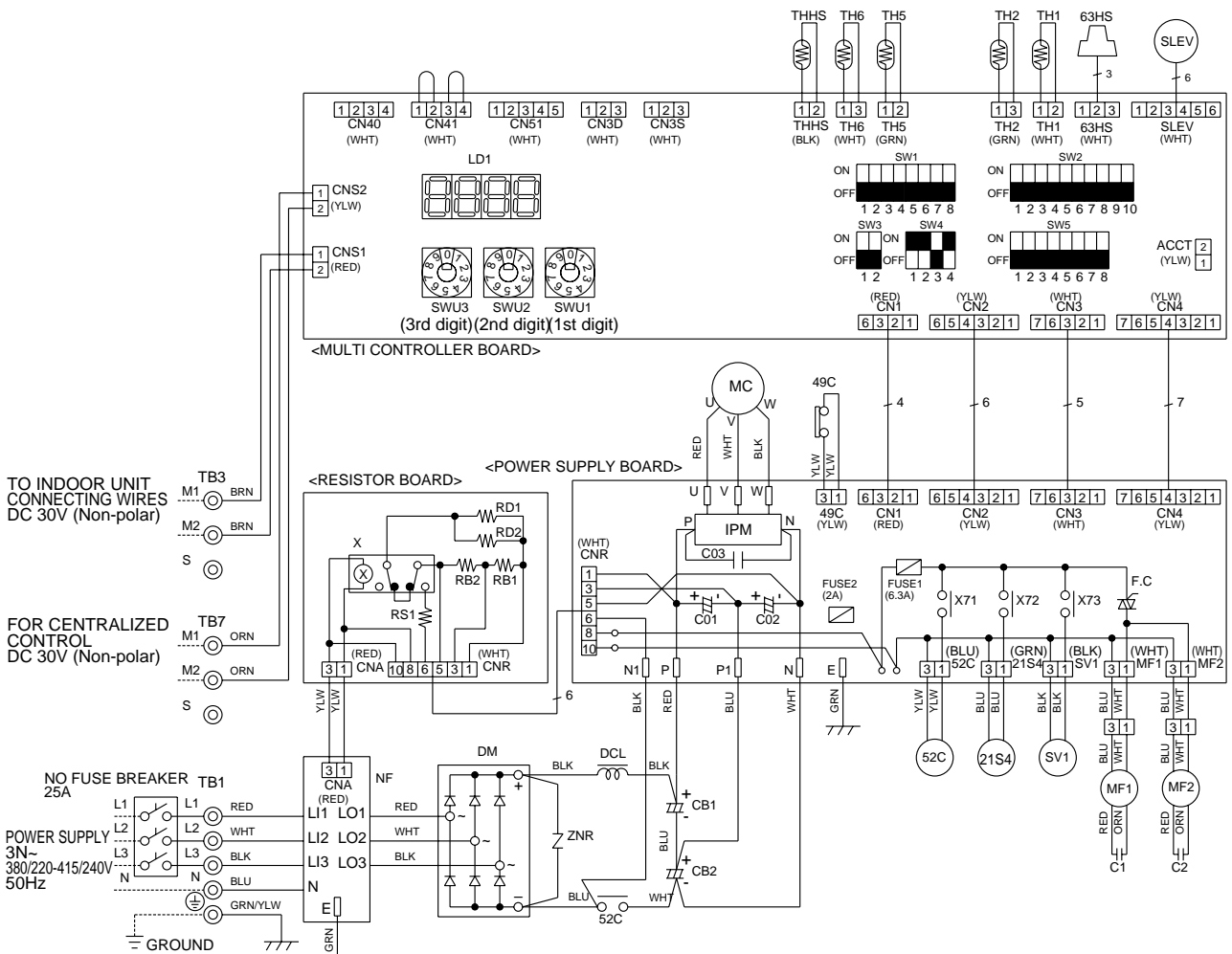

- NOTES: 1.Refer to the wiring diagrams of the indoor units for details on wiring of each indoor unit.
 2.Symbols used in wiring diagram above are. ⊙:Terminal block, □:Connector, □:Insertion tab.
 3.Self-diagnosis function
 The indoor and outdoor units can be diagnosed automatically using the self-diagnosis switch(SW1) and LD1(LED indication) found on the multi-controller of the outdoor unit.
 LED indication : Set all contacts of SW1 to OFF.
 4.For the system utilizing R-converter units(PAC-SF29LB), the following functions are not available.
 SW3 : TEST RUN SW5-1 : AUTO CHANGE OVER CN3D : AUTO CHANGE OVER(external signal)
 5.The input for CN3D 1-2(AUTO CHANGE OVER EXTERNAL SIGNAL)is as follows.
 Short : heating Open : Cooling(It differs from Service ref. PUMY-P125YMA)

- During normal operation
 The LED indicates the drive state of the controller in the outdoor unit.

Bit	1	2	3	4	5	6	7	8
Indication	Compressor operated	52C	21S4	SV1	-	-	-	Always lit

- When fault requiring inspection has occurred
 The LED alternately indicates the inspection code and the location of the unit in which the fault has occurred.

(Example)
 When the compressor and SV1 are turned during cooling operation.



8-1. TRANSMISSION SYSTEM SETUP

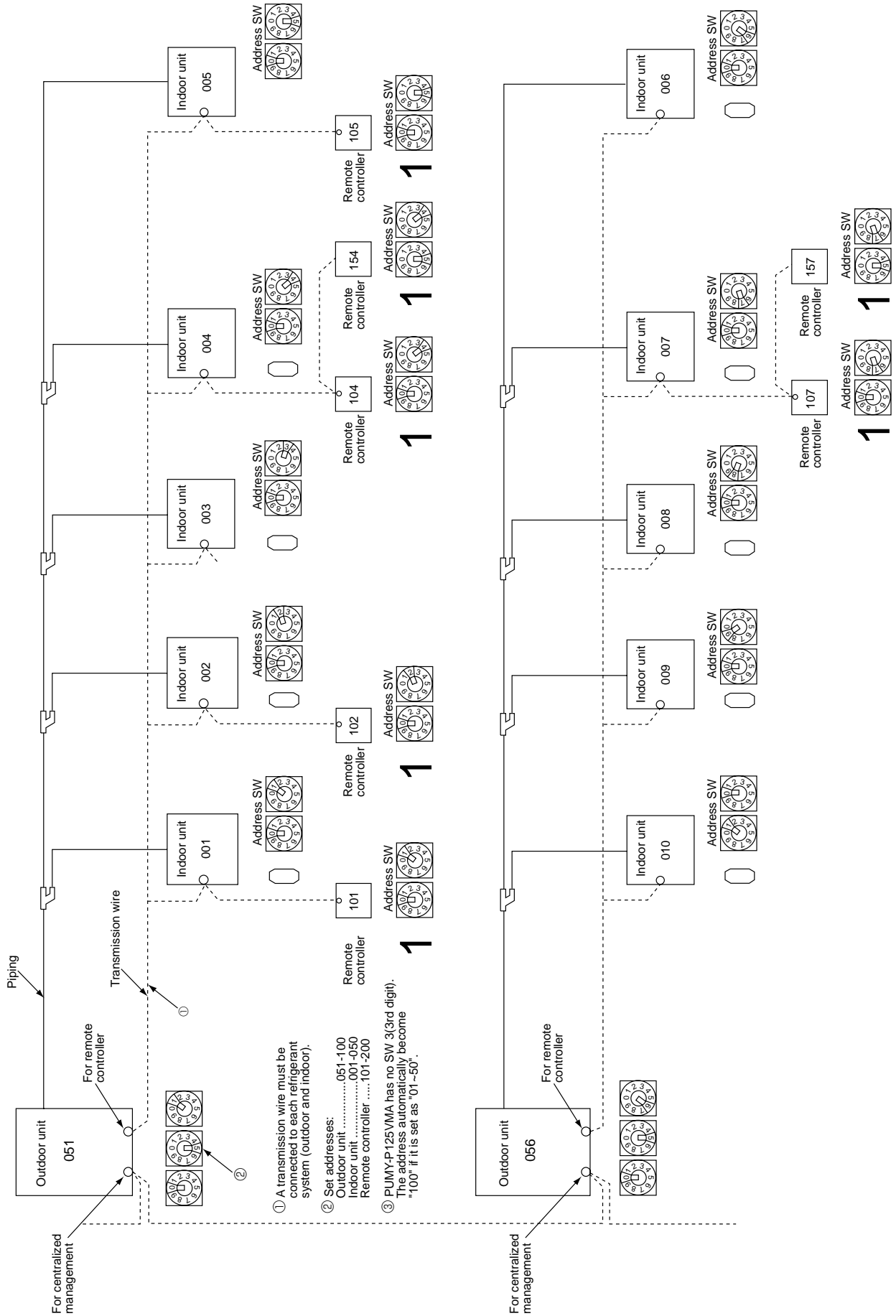

8-2. REFRIGERANT SYSTEM DIAGRAM

PUMY-P125VMA
 PUMY-P125VMA₁
 PUMY-P125YMA
 PUMY-P125YMA₁

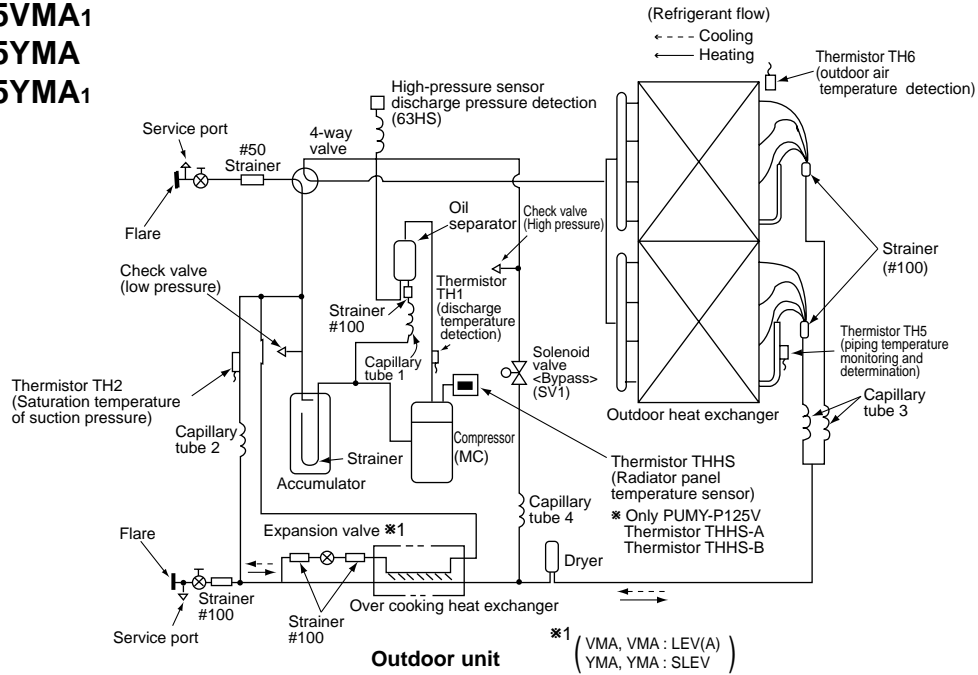

Refrigerant Piping Specifications (dimensions of flared connector)

Capacity		Item	Liquid piping	Gas piping
Indoor unit	20, 25, 32, 40		φ6.35 <1/4" >	φ12.7 <1/2" >
	50, 63, 71, 80		φ9.52 <3/8" >	φ15.88 <5/8" >
	100, 125		φ9.52 <3/8" >	φ19.05 <3/4" >
Outdoor unit	125		φ9.52 <3/8" >	φ19.05 <3/4" >

	Capillary tube 1 (for return of oil from oil separator)	Capillary tube 2 (for Evaporating temperature detection)	Capillary tube 3 (for maintaining equilibrium between upper and lower coils)	Capillary tube 4 (for SV1)
PUMY-P125VMA PUMY-P125VMA ₁ PUMY-P125YMA PUMY-P125YMA ₁	φ2.5 × φ0.6 × L500	φ2.5 × φ0.6 × L500	(φ4 × φ3.0 × L200) × 2	φ4 × φ2.4 × L360

Concerning the Compressor

This system has a scroll compressor. This compressor uses a low pressure shell that typically has a temperature in the range 30-80°C.

In addition, compressor wiring should be in the direction of rotation to the right. Wire colors are red (U), white (V), black (W), yellow and yellow (thermal switch).

8-3. SYSTEM CONTROL

8-3-1. Operating a Single Refrigerant System

When operating either alone or as part of a group, a M-NET remote controller (NR) may be used to control a single refrigerant system that does not overlap with any other system.

<Example of system arrangement>

Using a M-NET remote controller (NR)

- * Address setting must be performed.
- * The NR wire and indoor and outdoor transmission wires must be a non-polar two wire cable.
- * One NR may be connected to a maximum of 16 indoor unit.
- * Two NR units may be used to perform control tasks (the second one pressed will have priority if two are pressed simultaneously).
- * For the system utilizing R-Converter units (PAC-SF29LB), the following systems are not available. Group operation system, centralized controller, group remote controller, etc. (See the installation manual of R-Converter units.)

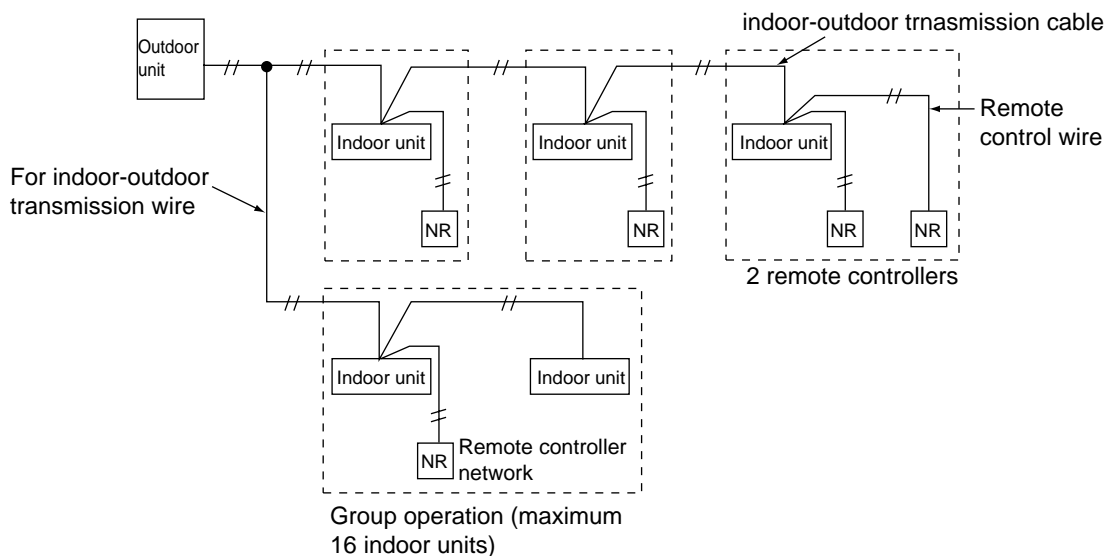

- * If the user plans to install multiple refrigerant systems and a centralized controller in the future, it is strongly suggested that a NR be used.

8-3-2. System Controller (SC) to Perform Centralized Control

<Example of System Arrangement>

The following diagram shows the use of system controller (SC) to control a system that includes the multiple outdoor unit.

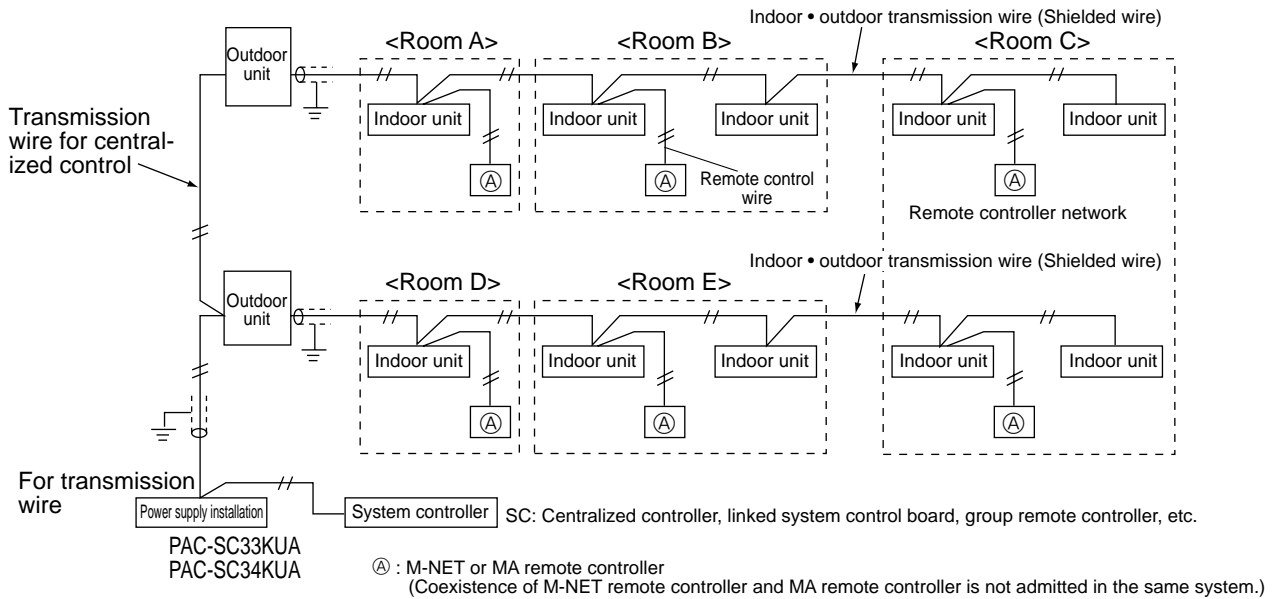

Note 1) The NR, SC, indoor and outdoor unit all require address settings.

Indoor unit	Linked settings must be made within a group.	1 ~ 50
Outdoor unit	The lowest address of an indoor unit within a refrigerant system is +50.	51 ~ 100 *
M-NET remote controller (Main)	The lowest address of an indoor unit within a group is +100.	101 ~ 150
M-NET remote controller (Sub)	The address of the main remote controller is +50.	151 ~ 200
SC		0 or 201 ~ 250
MA Remote controller	Unnecessary address setting (Necessary main/sub setting)	—

* The address automatically becomes “100” if it is set as “01~50”. (PUMY-P125VMA, PUMY-P125VMA₁)

2) Indoor unit that may be connected with an SC are shown as follows.

Centralized controller	50 group /50 units
Multi-unit controller board	24 group /50 units
Group controller	8 group /16 units

3) There may be a maximum of two controllers when a group has 16 indoor units or less.

4) The transmission wire must have a power supply when an SC is used. Please connect the power supply for the transmission wire to the centralized controller transmission wire.

SC with 2 units or less	Power supply for transmission wire PAC-SC33KU
SC with 3 to 5 units	Power supply for transmission wire PAC-SC34KU

5) Use a shielded wire (at least 1.25mm²) for the indoor, outdoor, and centralized controller transmission wires. In addition, all shielded wires in a system must be grounded at one point. If the length of the remote control wire exceeds 10m, use an insulated wire for the extra portion.

8-3-3. Example for the System

- Example for wiring control cables, wiring method and address setting, permissible lengths, and the prohibited items are listed in the standard system with detailed explanation.

The explanation for the system in this section : Use one single outdoor unit and multiple outdoor units for M-NET remote control system.

Use one single outdoor unit and multiple indoor units in the multiple outdoor units for the M-NET remote control system.

A. Example of a M-NET remote controller system (address setting is necessary.)

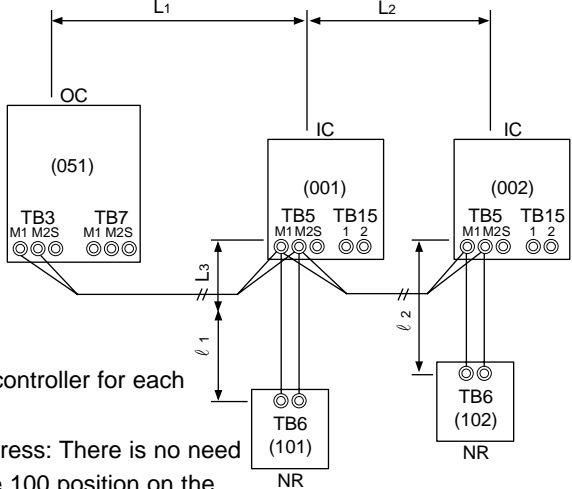
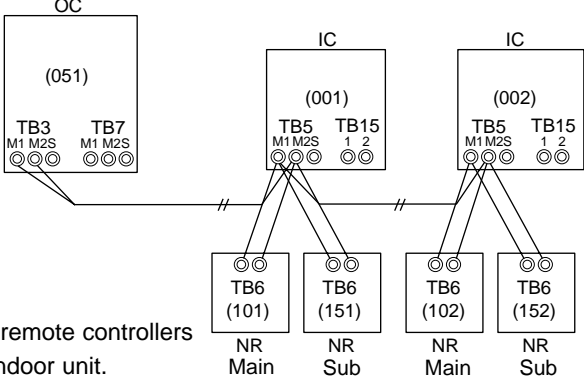
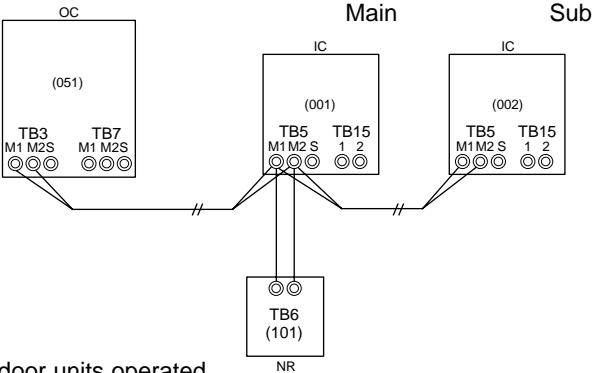
Example of wiring control cables	Wiring Method and Address Setting																		
<p>1. Standard operation</p>  <ul style="list-style-type: none"> • One remote controller for each indoor unit. • Inside () Address: There is no need for setting the 100 position on the remote controller. 	<p>a. Use feed wiring to connect terminals M1 and M2 on transmission cable block (TB3) for the outdoor unit (OC) to terminals M1 and M2 on the transmission cable block (TB5) of each indoor unit (IC). Use non-polarized two wire.</p> <p>b. Connect terminals M1 and M2 on transmission cable terminal block (TB5) for each indoor unit with the terminal block (TB6) for the remote controller (NR).</p> <p>c. Set the address setting switch as shown below.</p> <table border="1" data-bbox="836 862 1442 1070"> <thead> <tr> <th>Unit</th> <th>Range</th> <th>Setting Method</th> </tr> </thead> <tbody> <tr> <td>Indoor unit (IC)</td> <td>001 to 050</td> <td>—</td> </tr> <tr> <td>Outdoor unit (OC)</td> <td>051 to 100</td> <td>Use the most recent address of all the indoor unit plus 50.</td> </tr> <tr> <td>Remote controller (NR)</td> <td>101 to 150</td> <td>Indoor unit address plus 100.</td> </tr> </tbody> </table>	Unit	Range	Setting Method	Indoor unit (IC)	001 to 050	—	Outdoor unit (OC)	051 to 100	Use the most recent address of all the indoor unit plus 50.	Remote controller (NR)	101 to 150	Indoor unit address plus 100.						
Unit	Range	Setting Method																	
Indoor unit (IC)	001 to 050	—																	
Outdoor unit (OC)	051 to 100	Use the most recent address of all the indoor unit plus 50.																	
Remote controller (NR)	101 to 150	Indoor unit address plus 100.																	
<p>2. Operation using two remote controllers</p>  <ul style="list-style-type: none"> • Using two remote controllers for each indoor unit. 	<p>a. Same as above.</p> <p>b. Same as above.</p> <p>c. Set address switch as shown below.</p> <table border="1" data-bbox="836 1205 1442 1467"> <thead> <tr> <th>Unit</th> <th>Range</th> <th>Setting Method</th> </tr> </thead> <tbody> <tr> <td>Indoor Unit (IC)</td> <td>001 to 050</td> <td>—</td> </tr> <tr> <td>Outdoor unit (OC)</td> <td>051 to 100</td> <td>Use the most recent address of all the indoor units plus 50.</td> </tr> <tr> <td>Main Remote Controller (NR)</td> <td>101 to 150</td> <td>Indoor unit address plus 100.</td> </tr> <tr> <td>Sub Remote Controller (NR)</td> <td>151 to 200</td> <td>Indoor unit address plus 150.</td> </tr> </tbody> </table>	Unit	Range	Setting Method	Indoor Unit (IC)	001 to 050	—	Outdoor unit (OC)	051 to 100	Use the most recent address of all the indoor units plus 50.	Main Remote Controller (NR)	101 to 150	Indoor unit address plus 100.	Sub Remote Controller (NR)	151 to 200	Indoor unit address plus 150.			
Unit	Range	Setting Method																	
Indoor Unit (IC)	001 to 050	—																	
Outdoor unit (OC)	051 to 100	Use the most recent address of all the indoor units plus 50.																	
Main Remote Controller (NR)	101 to 150	Indoor unit address plus 100.																	
Sub Remote Controller (NR)	151 to 200	Indoor unit address plus 150.																	
<p>3. Group operation</p>  <ul style="list-style-type: none"> • Multiple indoor units operated together by one remote controller 	<p>a. Same as above.</p> <p>b. Connect terminals M1 and M2 on transmission cable terminal block (TB5) of the IC main unit with the most most recent address within the same indoor unit (IC) group to terminal block (TB6) on the remote controller.</p> <p>c. Set the address setting switch as shown below.</p> <table border="1" data-bbox="836 1691 1442 1993"> <thead> <tr> <th>Unit</th> <th>Range</th> <th>Setting Method</th> </tr> </thead> <tbody> <tr> <td>IC (Main)</td> <td>001 to 050</td> <td>Use the most recent address within the same group of indoor units.</td> </tr> <tr> <td>IC (Sub)</td> <td>001 to 050</td> <td>Use an address, other than that of the IC (Main) from among the units within the same group of indoor units. This must be in sequence with the IC (Main).</td> </tr> <tr> <td>Outdoor Unit</td> <td>051 to 100</td> <td>Use the most recent address of all the indoor units plus 50.</td> </tr> <tr> <td>Main Remote Controller</td> <td>101 to 150</td> <td>Set at an IC (Main) address within the same group plus 100.</td> </tr> <tr> <td>Sub Remote Controller</td> <td>151 to 200</td> <td>Set at an IC (Main) address within the same group plus 150.</td> </tr> </tbody> </table> <p>d. Use the indoor unit (IC) within the group with the most functions as the IC (Main) unit.</p>	Unit	Range	Setting Method	IC (Main)	001 to 050	Use the most recent address within the same group of indoor units.	IC (Sub)	001 to 050	Use an address, other than that of the IC (Main) from among the units within the same group of indoor units. This must be in sequence with the IC (Main).	Outdoor Unit	051 to 100	Use the most recent address of all the indoor units plus 50.	Main Remote Controller	101 to 150	Set at an IC (Main) address within the same group plus 100.	Sub Remote Controller	151 to 200	Set at an IC (Main) address within the same group plus 150.
Unit	Range	Setting Method																	
IC (Main)	001 to 050	Use the most recent address within the same group of indoor units.																	
IC (Sub)	001 to 050	Use an address, other than that of the IC (Main) from among the units within the same group of indoor units. This must be in sequence with the IC (Main).																	
Outdoor Unit	051 to 100	Use the most recent address of all the indoor units plus 50.																	
Main Remote Controller	101 to 150	Set at an IC (Main) address within the same group plus 100.																	
Sub Remote Controller	151 to 200	Set at an IC (Main) address within the same group plus 150.																	
<p>Combinations of 1 through 3 above are possible.</p>																			



• Name, Symbol and the Maximum Remote controller Units for Connection

Name	Symbol	Maximum units for connection
Outdoor unit	OC	
Indoor unit	IC	One OC unit can be connect to 1-8 IC units
M-NET remote controller	NR	Maximum two NR for one indoor unit, Maximum 16 NR for one OC

Permissible Lengths	Prohibited items
<p>Longest transmission cable length (1.25 mm²) $L_1 + L_2, L_2 + L_3, L_3 + L_1 \leq 200m$ Remote controller cable length 1. If 0.5 to 0.75 mm² $l_1, l_2 \leq 10m$ 2. If the length exceeds 10 meters, the exceeding section should be 1.25 mm² and that section should be a value within the total extension length of the transmission cable and maximum transmission cable length. (L₃)</p>	<ul style="list-style-type: none"> • M-NET remote controller(NR) and MA remote controller(MA) cannot be used together. • Do not connect anything with TB15 of indoor unit(IC).
Same as above	<ul style="list-style-type: none"> • Use the indoor unit(IC) address plus 150 as the sub remote controller address. In this case, it should be 152. • Three or more remote controller (NR) cannot be connected to one indoor unit.
Same as above	<ul style="list-style-type: none"> • The remote controller address is the indoor unit main address plus 100. In this case, it should be 101.

B. Example of a group operation system with two or more outdoor units and a M-NET remote controller.
(Shielding wires and address settings are necessary.)

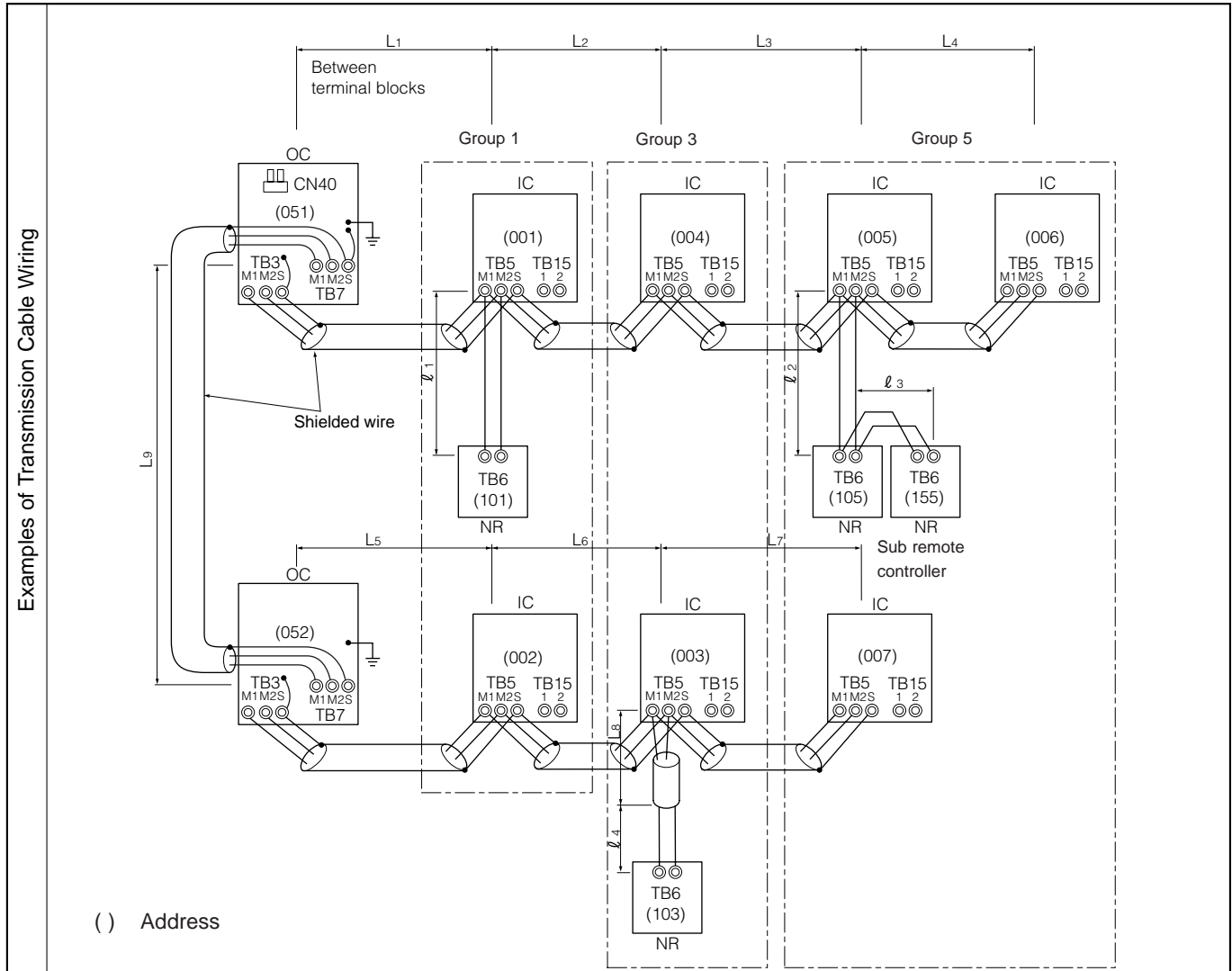

- Wiring Method Address Settings
- Always use shielded wire when making connections between the outdoor unit (OC) and the indoor unit (IC), as well for all OC-OC, and IC-IC wiring intervals.
 - Use feed wiring to connect terminals M1 and M2 and the ground terminal on the transmission cable terminal block (TB3) of each outdoor unit (OC) to terminals M1 and M2 on the terminal S on the transmission cable block of the indoor unit (IC).
 - Connect terminals M1 and M2 on the transmission cable terminal block of the indoor unit (IC) that has the most recent address within the same group to the terminal block (TB6) on the remote controller (NR).
 - Connect together terminals M1, M2 and terminal S on the terminal block for central control (TB7) for the outdoor unit (OC).
 - Use the grounded wire to connect the S-terminal on the transmission terminal of the outdoor unit (OC) and the grounded terminal for the electrical components box.
 - On one outdoor unit only, change the jumper connector on the control panel from CN41 to CN40.
 - Connect the terminal S on the terminal block for central control (TB7) for the outdoor unit (OC) for the unit into which the jumper connector was inserted into CN40 in Step above to the ground terminal ⊕ in the electrical component box.
 - Set the address setting switch as follows.
- | Unit | Range | Setting Method |
|------------------------|------------|---|
| IC (Main) | 001 to 050 | Use the most recent address within the same group of indoor units. |
| IC (Sub) | 001 to 050 | Use an address, other than that of the IC (Main) from among the units within the same group of indoor units. This must be in sequence with the IC (Main). |
| Outdoor Unit | 051 to 100 | Use the most recent address of all the indoor units plus 50. |
| Main Remote Controller | 101 to 150 | Set at an IC (Main) address within the same group plus 100. |
| Sub Remote Controller | 151 to 200 | Set at an IC (Main) address within the same group plus 150. |
- The group setting operations among the multiple indoor units is done by the remote controller (NR) after the electrical power has been turned on.

• Name, Symbol, and the Maximum Units for Connection

Permissible Length

- Max length via outdoor units : $L_1+L_2+L_3+L_4+L_5+L_6+L_7+L_9$
 $L_1+L_2+L_3+L_4+L_5+L_6+L_8+L_9 \leq 500$ meters (1.25mm²)
- Max transmission cable length : $L_1+L_2+L_3+L_4, L_5+L_6+L_7, L_5+L_6+L_8, L_7+L_8 \leq 200$ meters (1.25mm²)
- Remote controller cable length : $l_1, l_2, l_3, l_4 \leq 10$ meters (0.5 to 0.75mm²)
 If the length exceeds 10 meters, use a 1.25 mm² shielded wire. The length of this section (L₈) should be included in the calculation of the maximum length and overall length.

Prohibited items

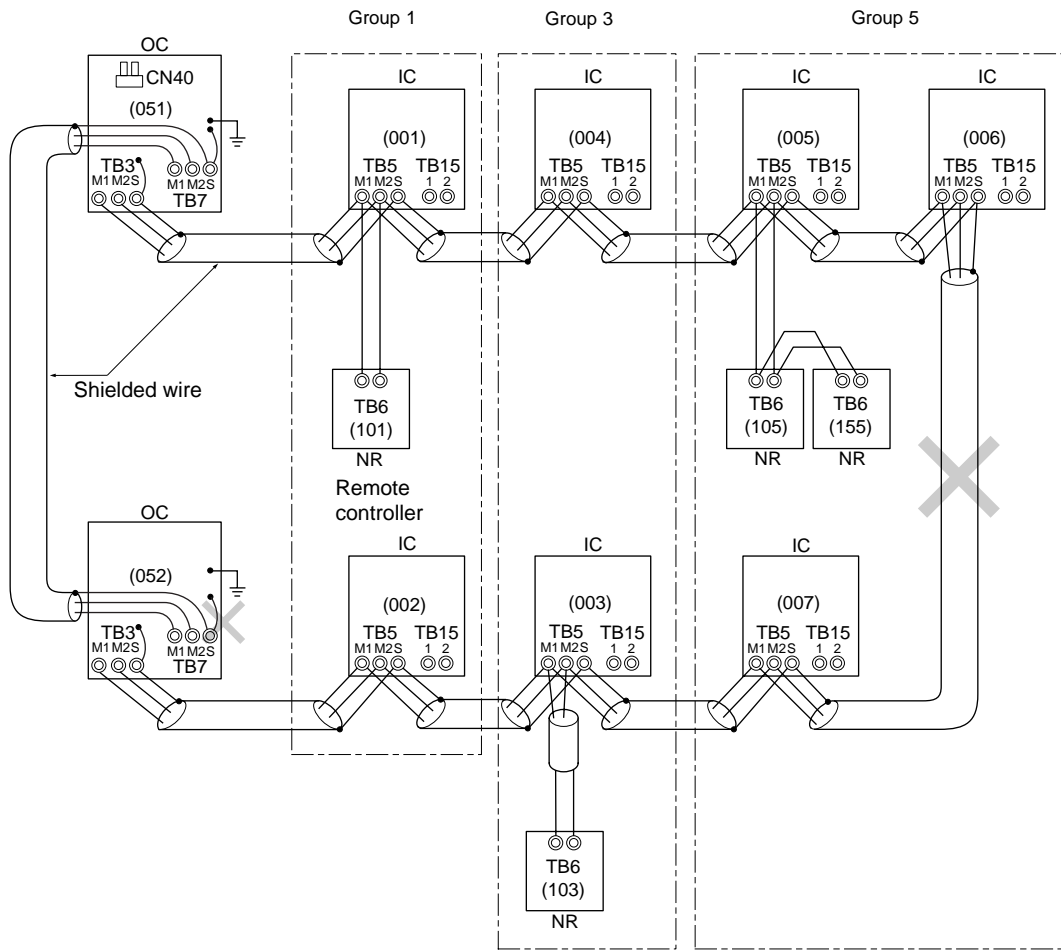

- The terminal S on the terminal block (TB7) for the central control panel should be connected to the ground terminal ⊕ of the electric components box for one outdoor unit only.
- Never connect together the terminal blocks (TB5) for transmission wires for indoor units (IC) that have been connected to different outdoor units (OC).
- Set all addresses to ensure that they are not overlapped.
- It cannot be connected M-NET remote controller and MA remote controller with indoor unit of the same group using together.

C. Example of a MA remote controller system (address setting is not necessary.)

NOTE : In the case of same group operation, need to set the address that is only main indoor unit.

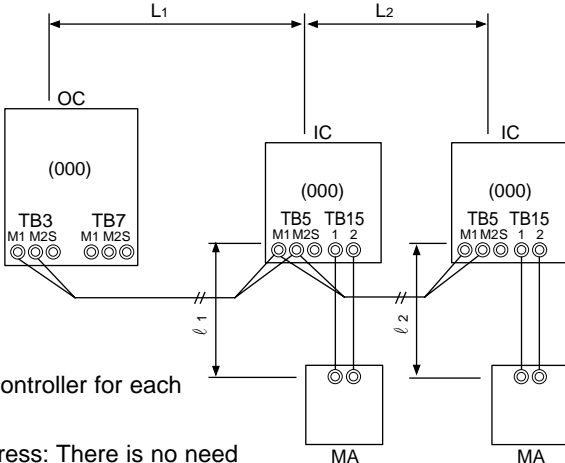
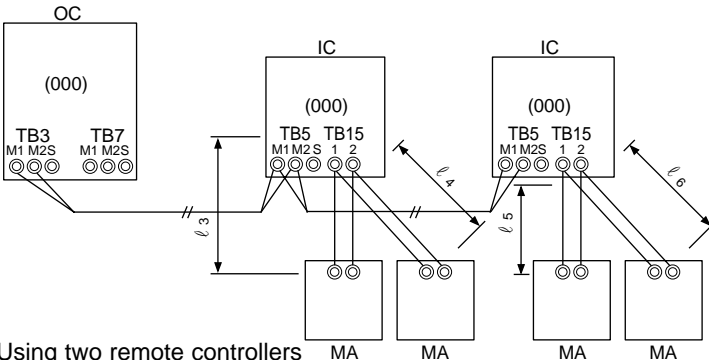
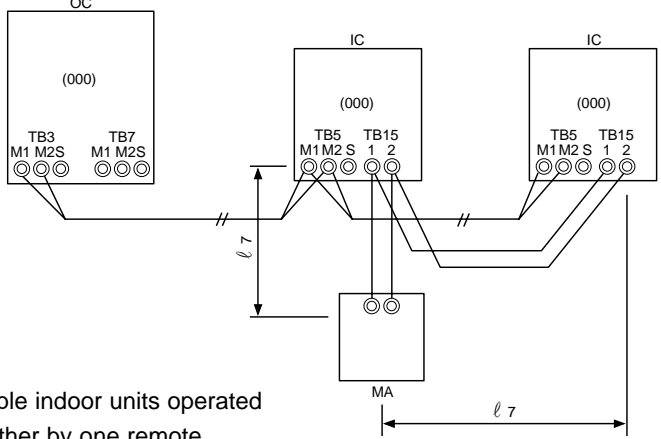
Example of wiring control cables	Wiring Method and Address Setting
<p>1. Standard operation</p>  <ul style="list-style-type: none"> • One remote controller for each indoor unit. • Inside () Address: There is no need for setting the 100 position on the remote controller. 	<p>a. Use feed wiring to connect terminals M1 and M2 on transmission cable block (TB3) for the outdoor unit (OC) to terminals M1 and M2 on the transmission cable block (TB5) of each indoor unit (IC). Use non-polarized two wire.</p> <p>b. Connect terminals 1 and 2 on transmission cable terminal block (TB15) for each indoor unit with the terminal block for the MA remote controller (MA).</p>
<p>2. Operation using two remote controllers</p>  <ul style="list-style-type: none"> • Using two remote controllers for each indoor unit. 	<p>a. The same as above.</p> <p>b. The same as above.</p> <p>c. In the case of using two remote controllers, connect terminals 1 and 2 on transmission cable terminal block (TB15) for each indoor unit with the terminal block for two remote controllers.</p> <ul style="list-style-type: none"> • Set the sub remote controller position for one of MA remote controller's main switch. Refer to the installation manual of MA remote controller
<p>3. Group operation</p>  <ul style="list-style-type: none"> • Multiple indoor units operated together by one remote controller 	<p>a. The same as above.</p> <p>b. The same as above.</p> <p>c. Connect terminals 1 and 2 on transmission cable terminal block (TB15) of each indoor unit, which is doing group operation with the terminal block the MA remote controller. Use non-polarized two wire.</p> <p>d. In the case of same group operation, need to set the address that is only main indoor unit. Please set the address of the indoor unit with the most functions in the same group in the number that 01-50 is young.</p>
<p>Combinations of 1 through 3 above are possible.</p>	

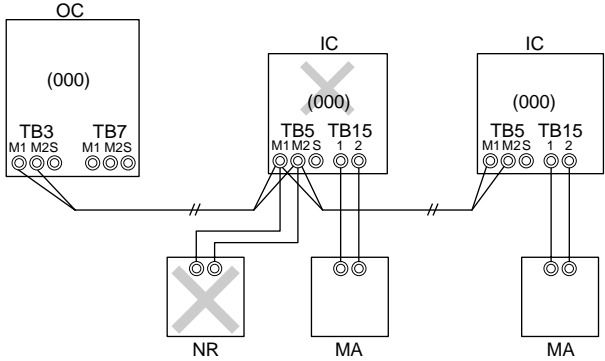
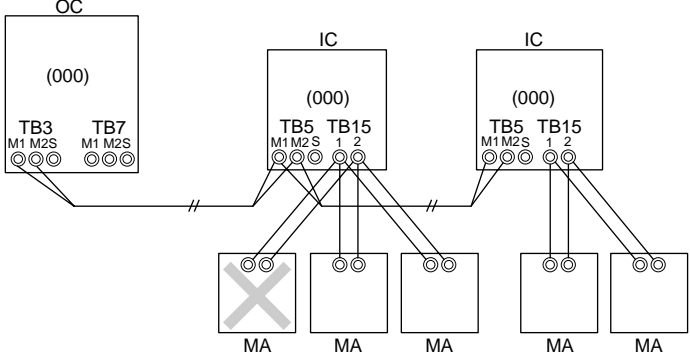
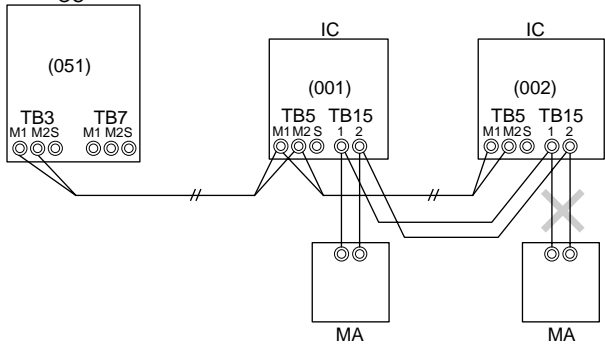

Permissible Lengths	Prohibited items
<p>Longest transmission cable length $L_1 + L_2 \leq 200\text{m}$ (1.25 mm²) MA remote controller cable length $l_1, l_2 \leq 200\text{m}$ (0.3 ~ 1.25 mm²)</p>	<p>The MA remote controller and the M-NET remote controller cannot be used together with the indoor unit of the same group.</p> 
<p>Longest transmission cable length The same as above. MA remote controller cable length $l_3 + l_4, l_5 + l_6 \leq 200\text{m}$ (0.3 ~ 1.25 mm²)</p>	<p>Three MA remote controller or more cannot connect with the indoor unit of the same group.</p> 
<p>Longest transmission cable length The same as above. MA remote controller cable length $l_7 + l_8 \leq 200\text{m}$ (0.3 ~ 1.25 mm²)</p>	<p>The second MA remote control is connected with the terminal block (TB15) for the MA remote control of the same indoor unit (IC) as the first remote control.</p> 

D. Example of a group operation with two or more outdoor units and a MA remote controller.
 (Shielding wires and address settings are necessary.)

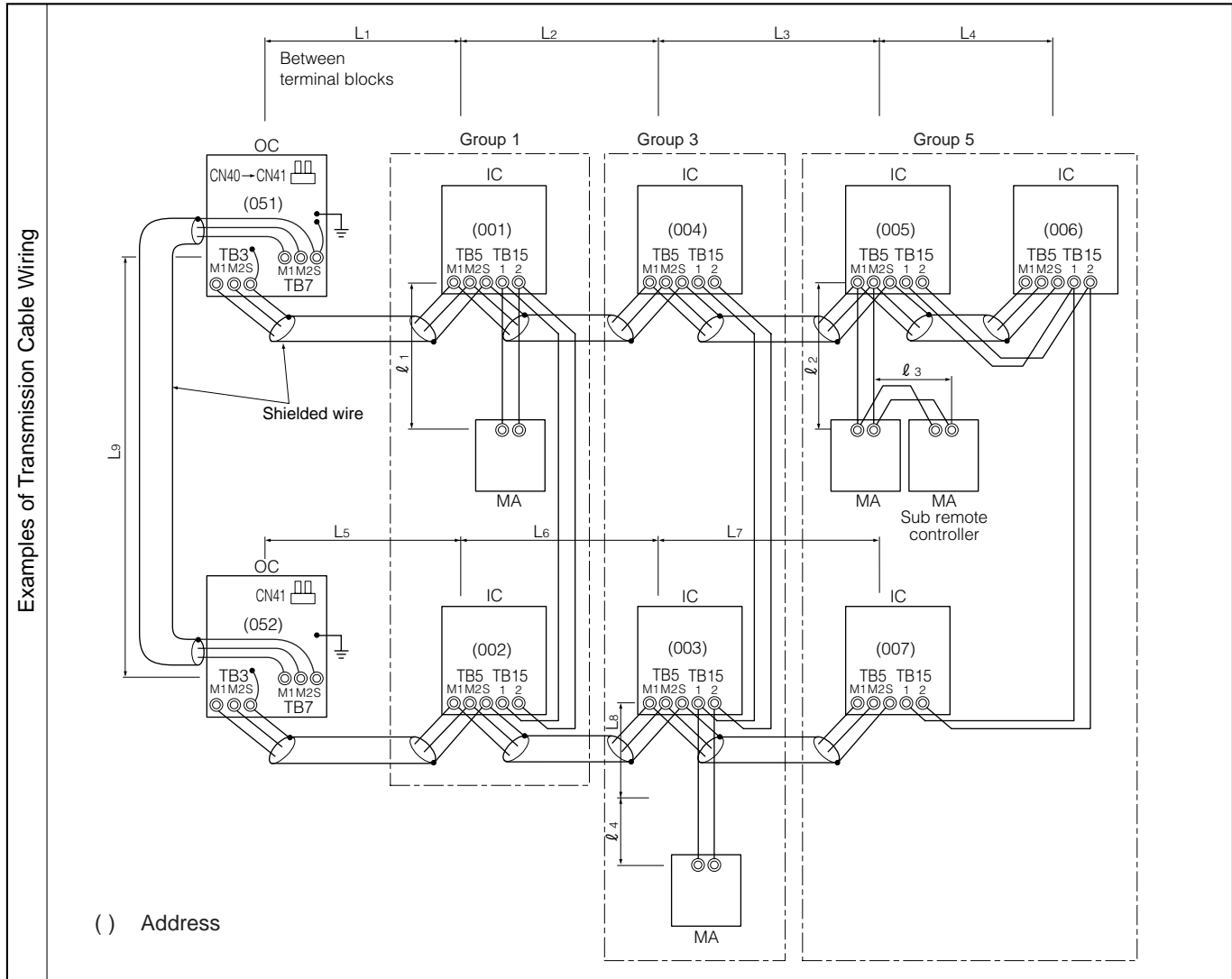

- Wiring Method Address Settings
- Always use shielded wire when making connections between the outdoor unit (OC) and the indoor unit (IC), as well for all OC-OC, and IC-IC wiring intervals.
 - Use feed wiring to connect terminals M1, M2 and S and the ground terminal on the transmission cable terminal block (TB3) of each outdoor unit (OC) to terminals M1, M2 and S on the transmission cable block (TB15) of the indoor unit (IC).
 - Connect terminals M1 and M2 on the transmission cable terminal block of the indoor unit (IC) that has the most recent address within the same group to the terminal block on the remote controller (MA).
 - Connect together terminals M1, M2 and terminal S on the terminal block for central control (TB7) for the outdoor unit (OC).
 - Use the grounded wire to connect the S-terminal on the transmission terminal of the outdoor unit (OC) and the grounded terminal for the electrical components box.
 - On one outdoor unit only, change the jumper connector on the control panel from CN41 to CN40.
 - Connect the terminal S on the terminal block for central control (TB7) for the outdoor unit (OC) for the unit into which the jumper connector was inserted into CN40 in Step above to the ground terminal ⊕ in the electrical component box.
 - Set the address setting switch as follows.

Unit	Range	Setting Method
IC (Main)	001 to 050	Use the most recent address within the same group of indoor units.
IC (Sub)	001 to 050	Use an address, other than that of the IC (Main) from among the units within the same group of indoor units. This must be in sequence with the IC (Main).
Outdoor Unit	051 to 100	Use the most recent address of all the indoor units plus 50.

• Name, Symbol, and the Maximum Units for Connection

- Permissible Length
- Max length via outdoor units : $L_1+L_2+L_3+L_4+L_5+L_6+L_7+L_9$
 $L_1+L_2+L_3+L_4+L_5+L_6+L_8+L_9 \leq 500$ meters (1.25mm²)
 - Max transmission cable length : $L_1+L_2+L_3+L_4$, $L_5+L_6+L_7$, $L_5+L_6+L_8$, $L_7+L_8 \leq 200$ meters (1.25mm²)
 - Remote controller cable length : $l_1, l_2, l_3, l_4 \leq 10$ meters (0.5 to 0.75mm²)
 If the length exceeds 10 meters, use a 1.25 mm² shielded wire. The length of this section (L₈) should be included in the calculation of the maximum length and overall length.

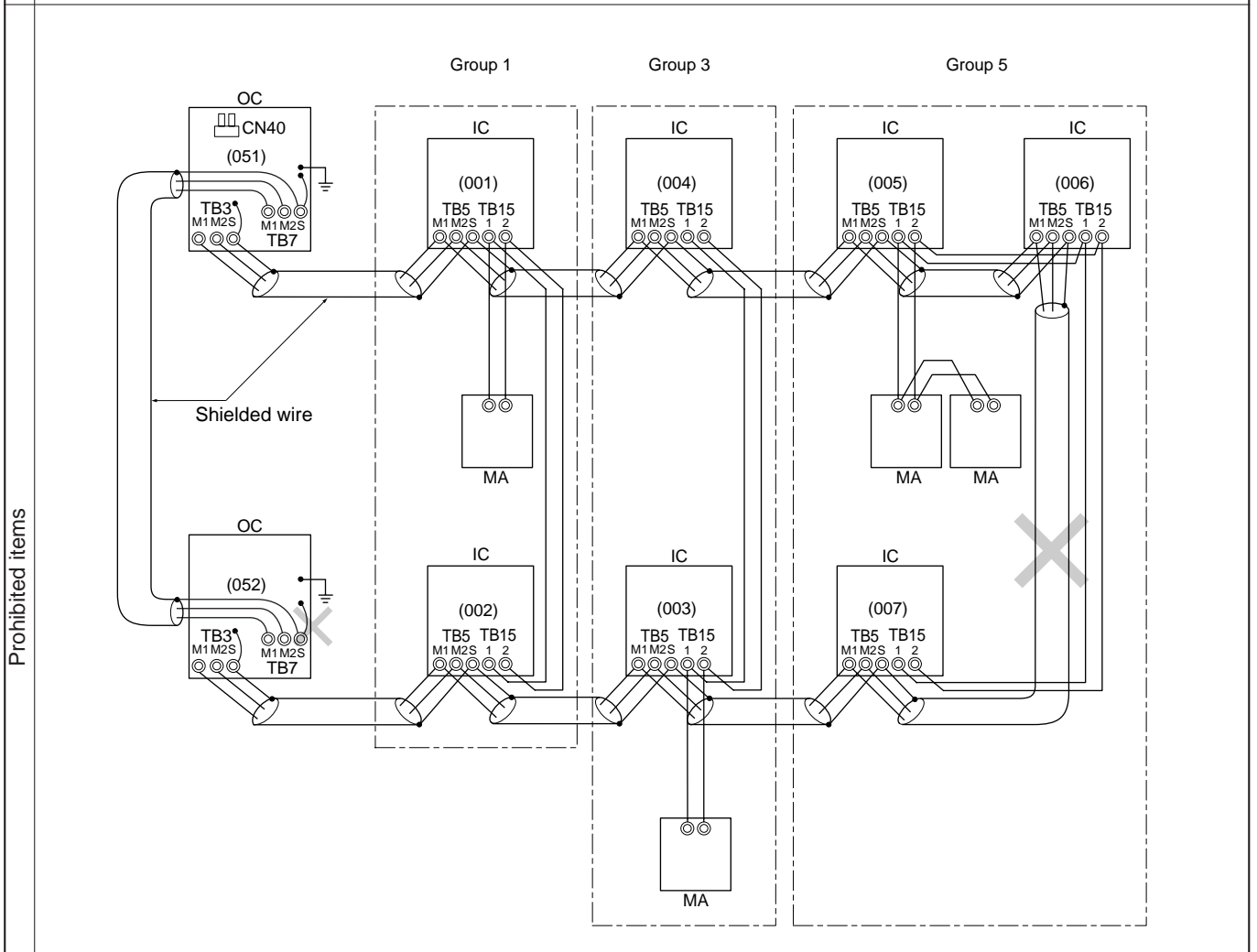

- The terminal S on the terminal block (TB7) for the central control panel should be connected to the ground terminal ⊕ of the electric components box for one outdoor unit only.
- Never connect together the terminal blocks (TB5) for transmission wires for indoor units (IC) that have been connected to different outdoor units (OC).
- M-NET remote controller and MA remote controller cannot be connected with the indoor unit of the same group wiring together

9-1. CHECK POINTS FOR TEST RUN

9-1-1. Procedures of test run

(1) Before test run, make sure that following work is completed.

- Installation related :

Make sure that the panel of cassette type and electrical wiring is done.
Otherwise electrical functions like auto vane will not operate normally.

- Piping related :

Perform leakage test of refrigerant and drain piping.
Make sure that all joints are perfectly insulated.

Check stop valves on both liquid and gas side for full open.

- Electrical wiring related :

Check ground wire, transmission cable, remote controller cable, and power supply cable for secure connection.

Make sure that all switch settings of address or adjustments for special specification systems are correctly settled.

(2) Safety check :

With the insulation tester of 500V, inspect the insulation resistance.

Do not touch the transmission cable and remote controller cable with the tester.

The resistance should be over 1.0 MΩ. Do not proceed inspection if the resistance is under 1.0 MΩ.

Inspect between the outdoor unit power supply terminal block and ground first, metallic parts like refrigerant pipes or the electrical box next, then inspect all electrical wiring of outdoor unit, indoor unit, and all linked equipment .

(3) Before operation :

a) Turn the power supply switch of the outdoor unit to on for compressor protection. For a test run, wait at least 12 hours from this point.

b) Register control systems into remote controller(s). Never touch the on/ off switch of the remote controller(s). Refer to “ 8-1-2 M-NET Remote Controller Settings” on page 29 as for settings . In MA remote controller(s), this registration is unnecessary.

(4) More than 12 hours later from power supply to the outdoor unit, turn all power switch to on for test run. Perform test run according to the “Operation procedure” table of the bottom of this page. While test running, make test run reports .

(5) When you deliver the unit after test run, instruct the end user for proper usage of the system using owners' manual and the test run report you made to certificate normal operation. If abnormalities are detected during test run, refer to “ 9-1-3 Countermeasures for Error During Test Run” on page 37. As for DIP switch setting of outdoor unit, refer to “ 9-5. INTERNAL SWITCH FUNCTION TABLE” on page 60.

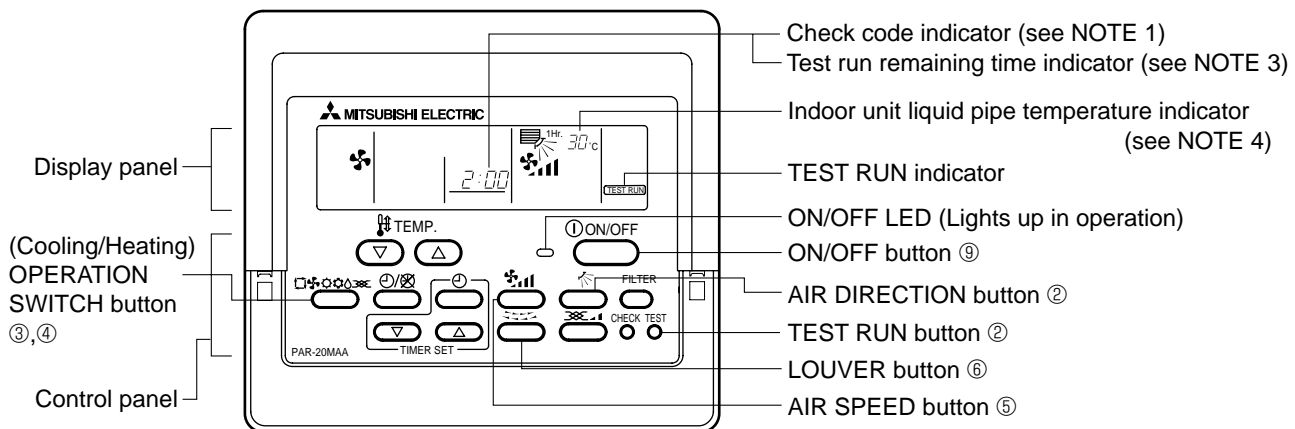

Operation procedure	
①	Turn on the main power supply the all units at least 12 hrs. before test run. "HO" appears on display panel for 3 min.
②	12 hrs later, press TEST RUN button twice to perform test run. "TEST RUN " appears on display panel.
③	Press OPERATION SWITCH button to make sure that air blows out.
④	Select Cooling (or Heating) by OPERATION SWITCH button to make sure that cool (or warm) air blow out.
⑤	Press Fan speed button to make sure that fan speed in changed by the button.
⑥	Press AIR DIRECTION button or LOUVER button to make sure that air direction is adjustable(horizontal, downward, upward, and each angle).
⑦	Check outdoor fans for normal operation.
⑧	Check interlocked devices (like ventilator) for normal operation, if any. This is the end of test run operation.
⑨	Press ON/OFF button to stop and cancel test run.
NOTE 1 : If error code appears on remote controller or remote controller malfunction , refer to “ 9-1-3 Countermeasures for Error During Run” on page 37.	
NOTE 2 : During test run operation 2-hours off timer activates automatically and remaining time is on remote controller and test run stops 2 later.	
NOTE 3 : During test run, the indoor liquid pipe temperature is displayed on remote controller instead of room temperature.	
NOTE 4 : Depend on a model, “This function is not available” is appears when air direction button is pressed, however, this is not malfunction.	

9-1-2. Special Function Operation and Settings (for M-NET Remote Controller)

- It is necessary to perform "group settings" and "paired settings" at making group settings of different refrigerant systems (multiple outdoor unit).
 - (A) Group settings: Enter the indoor unit controlled by the remote controller, check the content of entries, and clear entries, etc.
 - (B) Paired settings: Used to set the linked operation of a Lossnay unit.

(1) Entering address: Follow the steps below to enter the addresses of the indoor unit using the remote controller.

a) Group settings





- Turning off the remote controller: Press the ON/OFF button to stop operation (the indicator light will go off).
- Changing to indoor unit address display mode: If the FILTER and  buttons on the remote controller are pressed simultaneously and held for two seconds, the display shown in Figure 1 will appear.
- Changing address: Press the temperature adjustment   buttons to change the displayed address to the address to be entered.
- Entering the displayed address: Press the TEST RUN button to enter the indoor unit with the displayed address. The type of the unit will be displayed as shown in Figure 2 if entry is completed normally. If a selected indoor unit does not exist, an error signal will be displayed as shown in Figure 3. When this happens, check whether the indoor unit actually exists and perform entry again.
- Returning to the normal mode after completing entry: Press the FILTER and  buttons simultaneously and hold for two seconds to return to the normal mode.

Figure 1 (A) Group setting display

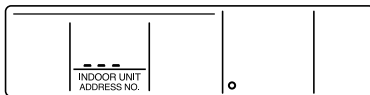
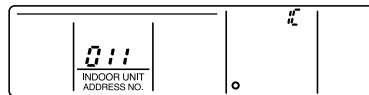
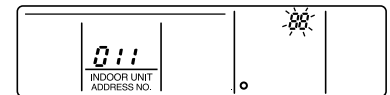

Figure 2 Normal completion of entry



Type of unit is displayed

Figure 3 Entry error signal



Flashing "88" indicates entry error

b) Paired Settings







- Turn off the remote controller: Press the remote controller's ON/OFF button to turn it off (the indicator light will go off).
- Put in indoor unit address display mode: Press the FILTER and  buttons on the remote controller simultaneously and hold for two seconds.
- *The above steps are the same as when making group settings (A).
- Changing to the linked operation unit address display state: The display shown in Figure 4 will appear when the  button on the remote control is pressed.
- Displaying the address of the Lossnay unit and linked indoor unit: In this situation, the indoor unit number will be the lowest address of the group. The Lossnay unit will not operate if this setting is incorrect.
- *If the temperature adjustment   buttons are pressed, the address may be changed to the indoor unit that are to be linked.
- *If the time setting   buttons are pressed, the address of the linked units may be changed to the address where it is desired to enter the Lossnay .
- Linking the Lossnay and the indoor unit: The display shown in Figure 5 will appear when the TEST RUN button is pressed. The indoor unit whose address is displayed and the Lossnay unit with a linked address will operate in a linked manner.
- *If it is desired to display the address of the Lossnay in the indoor unit address, display the indoor unit address in the linked unit address, and the above content will also be recorded.
- * Apart from the indoor unit with the lowest address in the group, display and enter the addresses of the other indoor unit that are to be linked with the Lossnay unit.
- Returning to the normal mode after completing entry: Press the FILTER and  buttons on the remote controller simultaneously and hold for two seconds to return to the normal mode.

Figure 4 (B) Making paired settings



The addresses of indoor unit and linked units are displayed simultaneously.

Figure 5 Completing normal entry

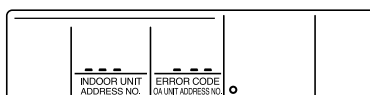
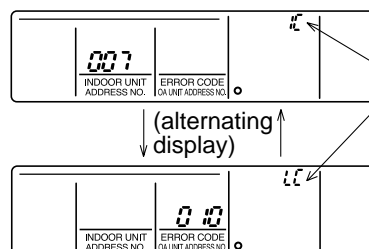



These alternating IC or LC displays will appear when entry is completed normally.





A flashing "88" will appear if there is a problem with the entry (indicating that the unit does not exist).

(2) Address check: Refer to section (1) regarding address entry.

a) In making group settings:

- Turn off the remote controller: Press the remote controller's ON/OFF button to stop operation (the indicator light will go off).
- Locate the indoor unit address display mode: Press the FILTER and  buttons on the remote controller simultaneously and hold for two seconds.
- Display indoor unit address: The entered indoor units address and type will be displayed each time the button is pressed.
* When one entry is made, only one address will be displayed no matter how many times the button is pressed.
- Returning to the normal mode after completing check: Simultaneously press the FILTER and  buttons on the remote controller and hold for two seconds to return to the normal mode.

b) In making paired settings:

- Turn off the remote controller: Press the remote controller's ON/OFF button to stop operation (the indicator light will go off).
- Put in indoor unit address display mode: Press the FILTER and  buttons on the remote controller simultaneously and hold for two seconds.
- Changing to the linked operation unit address display state: Press the  button on the remote control.
- Displaying the address of the indoor unit to be checked: Change the address to that of the indoor unit to be checked by pressing the temperature adjustment buttons .
- Displaying the address of the linked Lossnay unit: Press the button to display the addresses of the linked Lossnay and indoor unit in alternation.
- Displaying the addresses of other entered units: The addresses of the other entered units will be displayed in alternating fashion after resting the button again.
- Returning to the normal mode after completing the check: Simultaneously press the FILTER and  buttons on the remote controller and hold for two seconds to return to the normal mode.

(3) Clearing an address: Refer to section (1) regarding the address entry and section (2) regarding checking addresses.

a) In making group settings:

- Turn off the remote controller: The procedure is same as **a)** in (2) Address check.
- Put in the indoor unit address display mode: The procedure is same as **a)** in (2) Address check.
- Displaying the indoor unit address to be cleared: The procedure is same as **a)** in (2) Address check.
- Clearing indoor unit address :Pressing the  button on the remote controller twice will clear the address entry of the displayed indoor unit, resulting in the display shown in Figure 6.
The display shown in Figure 7 will appear if an abnormality occurs and the entry is not cleared.
Please repeat the clearing procedure.
- Returning to the normal mode after clearing an address: The procedure is same as **a)** in (2) Address check.

Figure 6 Display after address has been cleared normally

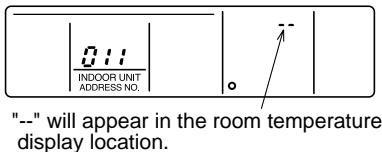
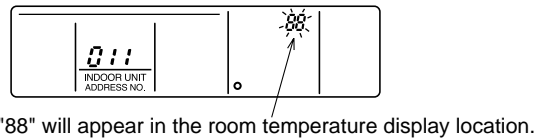

Figure 7 Display when an abnormality has occurred during clearing



b) In making paired settings:

- Turn off the remote controller: The procedure is same as **b)** in (2) Address check.
- Put into the indoor unit address display mode: The procedure is same as **b)** in (2) Address check.
- Put into the linked unit address display mode: The procedure is same as **b)** in (2) Address check.
- Display the address of the Lossnay unit or the indoor unit to be cleared.
- Deleting the address of a linked indoor unit: Pressing the  button on the remote controller twice will clear the address entry of the displayed indoor unit, resulting in the display shown in Figure 8.
- Returning to the normal mode after clearing an address: The procedure is same as **b)** in (2) Address check.

Figure 8 Display after address has been cleared normally



9-1-3. Countermeasures for Error During Test Run

- If a problem occurs during test run, a code number will appear in the temperature display area on the remote controller (or LD1 on the outdoor unit), and the air conditioning system will automatically cease operating.

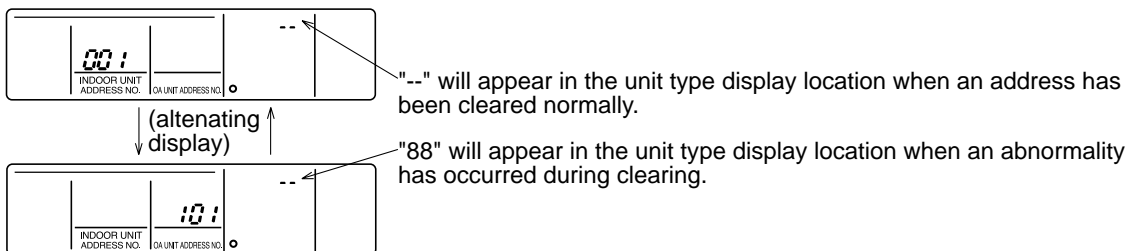
Determine the nature of the abnormality and apply corrective measures.

Check code	Trouble	Check code	Trouble
1102	Discharge temperature trouble	6600	Duplicated unit address setting
1108	Compressor's inner thermal sensor trouble	6602	Transmission error (Transmission processor hardware error)
1302	High pressure trouble		
1500	Excessive refrigerant replenishment	6603	Transmission error (Transmission route BUSY)
1501	Insufficient refrigerant	6606	Transmission and reception error (Communication trouble with transmission processor)
1505	Vacuum operation protection		
2502	Drain pump trouble	6607	Transmission and reception error (No ACK error)
2503	Drain sensor trouble (THd)	6608	No response
4115	Power synchronization signal trouble	6831	MA communication receive signal error (no receive signal)
4116	Indoor unit fan rotation trouble		
4220	Inverter main voltage drop	6832	MA communication send signal error (starting bit detection error)
4230	Overheat protection of radiator panel		
4250	Multiple IPM errors (Over current trouble)	6833	MA communication send error (H/W error)
5101	Intake thermistor trouble (TH21) or discharge thermistor trouble (TH1)	6834	MA communication receive error (Synchronous recovery error)
5102	Liquid pipe thermistor trouble (TH22) or low pressure saturation thermistor trouble (TH2)	7100	Total capacity error
		7101	Capacity code error
5103	Gas pipe temperature sensor trouble (TH23)	7102	Connecting unit number error
5105	Piping temperature sensor trouble (TH5)	7105	Address set error
5106	Outdoor temperature sensor trouble (TH6)	7111	Remote controller sensor trouble
5110	ACTM/IGBT Radiator panel thermistor trouble (THHS-A/B) (PUMY-P125VMA, PUMY-P125VMA ₁)	0403	Communication trouble with Power Board (PUMY-P125VMA, PUMY-P125VMA ₁)
	IPM Radiator panel thermistor trouble (THHS) (PUMY-P125YMA, PUMY-P125YMA ₁)		
5201	Pressure sensor trouble (63HS)		
5300	Current sensor error (PUMY-P125VMA,PUMY-P125VMA ₁)		

The operational status of the outdoor unit controller is displayed on the LD1 of the outdoor unit under normal conditions (when all SW1's are OFF)

Field	1	2	3	4	5	6	7	8
Display item	Compressor is operating	52C	21S4	SV1	—	—	—	Lit steadily

Example: When the air conditioner is in the heating mode and the SV1 and compressor turned on.

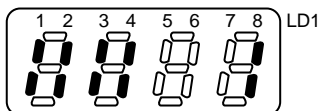



- 52C : Compressor Contactor
- 21S4 : Four-way valve
- SV1 : Bypass valve

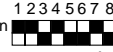

Display	Meaning and detecting method	Causes	Check points
1102	<p>Discharge temperature abnormality</p> <p>① When the discharge temperature thermistor (TH1) detects 125°C or more (1st detection), the compressor stops and restarts operation in 3 minutes.</p> <p>② When the thermistor detects 125°C or more again (2nd detection) within 30 minutes since the compressor has stopped, the compressor stops and restarts operation in 3 minutes.</p> <p>③ When the thermistor detects 125°C or more again (3rd detection) within 30 minutes since the compressor has stopped 2 times, the compressor stops abnormally. <1102> is displayed.</p> <p>④ When the thermistor detects 125°C or more after 30 minutes since the compressor has stopped (1st or 2nd time), it becomes the 1st detection or the same performance as above-mentioned ①.</p> <p>⑤ It is being delay for abnormal stop during 30 minutes since the compressor has stopped. In this time, check delay code <1202> will be displayed.</p>	<p>1) Gas leakage, Gas shortage</p> <p>2) Overloaded operation</p> <p>3) Indoor linear expansion valve operation defective</p> <p>4) Ball valve operation defective</p> <p>5) Outdoor fan block and defective of fan motor (heating mode)</p> <p>6) Gas leakage between high and low pressure (Defective of 4-way valve or compressor)</p> <p>7) Solenoid valve (SV1) performance defective (control failure to prevent the discharge temp. from rising by SV1)</p> <p>8) Thermistor defective</p> <p>9) Input circuit defective of multi controller board</p>	<p>Check the refrigerant amount.</p> <p>Check the indoor/outdoor unit operating condition and status.</p> <p>Perform cool or heat operation to check the condition.</p> <p>Check ball valve is fully opened.</p> <p>Check the outdoor fan motor.</p> <p>Check the operating condition.</p> <p>Check the solenoid valve performance.</p> <p>Check the thermistor resistance.</p> <p>Check the intake temperature in discharge temperature thermistor (TH1) by LD1. (See 5101 Discharge temperature thermistor error)</p>
1108	<p>Compressor inner thermo abnormality</p> <p>① When the inner thermo performs (1st detection) during the compressor operation, the compressor stops and restarts operation in 3 minutes.</p> <p>② When the inner thermo performs again (2nd detection) within 30 minutes since the compressor has stopped, or does not recover within 30 minutes, it stops abnormally. In this time <1108> is displayed.</p> <p>③ When the inner thermo performs after 30 minutes since the compressor has stopped (1st stop), it is the 1st detection and becomes the same performance as above-mentioned ①.</p> <p>④ It is being delay for abnormal stop during 30 minutes since the compressor has stopped. In this time, check delay code <1208> will be displayed.</p>	<p>1) Low voltage supplied to power supply terminal block</p> <p>2) Power supply L2 or L3 phase is opened. (When L1 phase is opened, power supply of the micro computer is not supplied.)</p> <p>3) Compressor failure (Over current by motor rare short, etc.)</p> <p>4) Overloaded operation</p> <p>5) Gas leakage, Gas shortage</p> <p>6) Inner thermo defective</p> <p>7) Input circuit defective of multi controller board or power supply board</p>	<p>Measure the terminal voltage.</p> <p>Check the voltage reduction.</p> <p>Check the open phase.</p> <p>Check the coil resistance.</p> <p>Check the indoor/outdoor unit operating condition and status.</p> <p>Check the refrigerant amount.</p> <p>Check the current flows in inner thermo.</p> <p>When the inner thermo is normal and input circuit is defective, even if the inner thermo performs, the compressor does not operate and becomes error in 30 minutes.</p>
1302	<p>High-pressure pressure abnormality</p> <p>① When high-pressure pressure sensor detects 2.94MPa or more (1st detection) during the compressor operation, the compressor stops and restarts operation in 3 minutes</p>	<p>1) Indoor unit short cycle</p> <p>2) Indoor unit filter clogging</p> <p>3) Air flow capacity decrease due to indoor fan dirt</p> <p>4) Indoor heat exchanger dirt</p>	<p>Check the indoor unit.</p> <p>Check the indoor unit filter.</p> <p>Check the indoor fan.</p> <p>Check the indoor unit heat exchanger.</p>

Display	Meaning and detecting method	Causes	Check points
1302	<p>② When the sensor detects 2.94MPa or more again (2nd detection) within 30 minutes since the compressor has stopped, the compressor stops again and restarts operation in 3 minutes.</p> <p>③ When the sensor detects 2.94MPa or more again (3rd detection) within 30 minutes since the compressor has stopped, the compressor stops again and restarts operation in 3 minutes.</p> <p>④ When the sensor detects 2.94MPa or more again (4th detection) within 30 minutes after 3rd compressor stop, it stops abnormally. In this time <1302> is displayed.</p> <p>⑤ When the sensor detects 2.94MPa or more after 30 minutes since the compressor has stopped (1st or 2nd or 3rd time), it becomes the 1st detection or the same performance as above-mentioned ①.</p> <p>⑥ It is being delay for abnormal stop during 30 minutes since the compressor has stopped. In this time, check delay code <1402> will be displayed.</p> <p>Note) For first 7 minutes in COOL or HEAT starting, error detected pressure of high-pressure pressure sensor is 3.14MPa.</p>	<p>5) Indoor fan motor lock</p> <p>6) Indoor fan motor failure</p> <p>7) 4-way valve performance failure (Stop in the middle of performance)</p> <p>8) Ball valve performance failure (not full-opened)</p> <p>9) Pipe clogged or broken</p> <p>10) Indoor linear expansion valve performance failure</p> <p>11) Outdoor fan motor lock</p> <p>12) Outdoor fan motor failure</p> <p>13) Outdoor unit short cycle</p> <p>14) Outdoor heat exchanger dirt</p> <p>15) Decrease in airflow capacity which the outdoor unit intakes because of intake defective of outer temperature thermistor. (Intake less than the actual outer air)</p> <p>16) Indoor unit capacity codes miss setting (If the capacity code is set greatly, initial frequency rises and high-pressure is easy to rise.)</p> <p>17) Solenoid valve (SV1) performance failure (High-pressure pressure cannot be controlled by SV1)</p> <p>18) Indoor thermistor (liquid pipe temperature detection) detecting failure (thermistor removed) (Hot adjust time becomes long.)</p> <p>19) High-pressure pressure sensor defective</p> <p>20) High-pressure pressure sensor input circuit defective in multi controller board.</p>	<p>Check the indoor fan motor.</p> <p>Check the indoor fan motor.</p> <p>Change COOL/HEAT operation mode to perform the 4-way valve. If any defective, replace the 4-way valve.</p> <p>Check the ball valve full-opened.</p> <p>Repair the defective points.</p> <p>Operate COOL or HEAT operation, and check the operation condition.</p> <p>Check the outdoor unit fan motor.</p> <p>Check the outdoor unit fan motor.</p> <p>Check the outdoor unit.</p> <p>Check the outdoor unit heat exchanger.</p> <p>Check intake temperature of the outer temperature thermistor by LD1. (See 5106 Outer temperature thermistor error)</p> <p>Check the capacity set switch in the indoor controller board. If it is wrong setting reset it. Check is available for the outdoor unit. (See 7101 Capacity code error)</p> <p>Check the solenoid valve performance.</p> <p>Check the thermistor installed condition. Operate in trial mode and check the pipe temperature change by the remote controller.</p> <p>Check the high-pressure pressure sensor.</p> <p>Check the high-pressure pressure sensor.</p>
1500	<p>Refrigerant over charged abnormality</p> <p>① When below 5 conditions are satisfied during the compressor operation (1st detection), the compressor stops and restarts operation in 3 minutes.</p> <p>1. Cool mode, outer temp. is 20°C or more Heat mode, outer temp. is 15°C or less</p>	<p>1) Refrigerant over charged</p> <p>2) Light-loaded operation (Wrong determination)</p> <p>3) Performance defective of the indoor's linear expansion valve and outdoor's electronic expansion valve.</p>	<p>Check the refrigerant amount.</p> <p>Check the indoor/outdoor unit operating condition and status.</p> <p>Perform cool or heat operation to check the condition.</p>

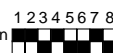
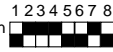
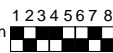
Display	Meaning and detecting method	Causes	Check points
1500	<p>2. The compressor has operated consecutively 20 minutes or more, since the indoor unit operation capacity had changed (including the compressor operation start).</p> <p>3. Operation frequency is 80Hz or more.</p> <p>4. Discharge super heat is below 10℃.</p> <p>5. Sub cool step continues for 5 minutes or more by SN=4.</p> <p>② Same condition as ① is satisfied again within 60 minutes since the compressor has stopped, it stops abnormally. In this time, <1500> is displayed.</p> <p>③ Same condition as ① is satisfied again after 60 minutes since the compressor has stopped (1st time), it becomes the first detection and same performance as ①.</p> <p>④ It is being delay for abnormal stop during 60 minutes since the compressor has stopped. In this time, check delay code <1600> will be displayed.</p>	<p>4) Discharge super heat detection error</p> <p>① High-pressure pressure sensor failure</p> <p>② Discharge temperature thermistor failure</p> <p>③ Thermistor input circuit defective in the multi controller board., and high-pressure pressure sensor input circuit failure</p>	<p>① Check the high-pressure pressure sensor.</p> <p>② Check the resistance of discharge temp. thermistor.</p> <p>③ Set the SW1 to  and check the high-pressure pressure sensor level.</p> <p>Set the SW1 to  and check the discharge temp. thermistor level.</p> <p>When the high-pressure pressure sensor and discharge temp. thermistor are normal, if the above mentioned detecting pressure level and temp. are big different from the actual pressure and temp., replace the multi controller board.</p>
1501	<p>Refrigerant shortage abnormality</p> <p>① When the conditions of below detecting mode I or II are satisfied (1st detection) during the compressor operation, the compressor stops and restarts operation in 3 minutes. <Detecting mode I > When the below conditions are satisfied completely.</p> <ol style="list-style-type: none"> SW5-5 is OFF. Compressor is operating in HEAT mode. Discharge super heat is 60℃ or more. Difference of outer temperature thermistor (TH6) and outdoor piping temp. thermistor (TH5) applies to the formula of (TH6-TH5)<5℃. High-pressure pressure sensor is below 1.08MPa. <p><Detecting mode II > When the below conditions are satisfied completely.</p> <ol style="list-style-type: none"> Compressor is operating. When cooling, discharge super heat is 70℃ or more. <p>When heating, discharge super heat is 95℃ or more.</p> <p>② When the conditions of detecting mode I and II are satisfied again (2nd detection) within 30 minutes since the compressor has stopped, it stops abnormally. In this time, <1501> is displayed.</p> <p>③ When the conditions of detecting mode I and II are satisfied again after 30 minutes since the compressor has stopped (1st time), it becomes the 1st detection and same performance as above ①.</p> <p>④ It is being delay for abnormal stop during 30 minutes since the compressor has stopped. In this time, check delay code <1600> will be displayed.</p>	<ol style="list-style-type: none"> Gas leakage, Gas shortage When heating operation, refrigerant shortage feeling operation (When heating, air flow or thermo OFF are mixed-operation, it cause a refrigerant shortage operation.) Ball valve performance failure (not full opened.) Error detection of discharge super heat <p>① High-pressure pressure sensor defective</p> <p>② Discharge temperature thermistor defective</p> <p>③ Thermistor input circuit defective and high-pressure pressure sensor defective in multi controller board</p> <p>5) Error detection of TH5/TH6</p> <p>① Thermistor defective</p> <p>② Thermistor input circuit defective in multi controller board</p>	<p>Check the refrigerant amount.</p> <p>Check the operation condition and refrigerant amount.</p> <p>Check the ball valve is full opened.</p> <p>① Check the high-pressure pressure sensor.</p> <p>② Check the resistance of discharge temperature thermistor.</p> <p>③ Set the SW1 to  and check the high-pressure pressure sensor level.</p> <p>Set the SW1 to  and check the discharge temp. thermistor level.</p> <p>When the high-pressure pressure sensor and discharge temp. thermistor are normal, if the above mentioned detecting pressure level and temp. are big different from the actual pressure and temp. replace the multi controller board.</p> <p>① Check the resistance of thermistor.</p> <p>② Set the SW1 to  and check the outdoor pipe temp. thermistor level.</p> <p>③ Set the SW1 to  and check the outer temp. thermistor level.</p>



Display	Meaning and detecting method	Causes	Check points
1505	<p>Vacuum operation protection</p> <p>When the suction pressure saturation temperature thermistor (TH2) detects -13°C or less and "[indoor temperature-liquid pipe temperature]$\leq 8^{\circ}\text{deg}$" for 3minutes continuously, the 1st COOL operation (compressor operation) after power supply on, it stops abnormally. In this time, <1505> is displayed</p>	<ol style="list-style-type: none"> 1) Ball valve performance failure (not full opened.) 2) Light-loaded operation (When outer temperature is low, the operation is liable to change to this mode.) 3) Low-pressure over suction by refrigerant shortage 4) Pipe clogging and broken 5) Indoor linear expansion valve performance defective 	<p>Check the ball valve is full opened.</p> <p>Check the indoor/outdoor unit operating condition and status.</p> <p>Check the refrigerant amount.</p> <p>Repair the defective points.</p> <p>Perform cool or heat operation to check the condition.</p>
2502	<p>Drain pump abnormality</p> <p>① When either of the undermentioned condition is satisfied (when determined drain sensor goes under water) while the indoor unit operation (excluding the case of abnormal stop) and after 3minutes since the drain pump has operated, the indoor unit stops abnormally (however fan continues the normal control). In this time, <2502> is displayed.</p> <ul style="list-style-type: none"> · Turn on the side heater of drain sensor, then when temperature up from the detected temperature before turning on is below 20°C during 40 seconds. · The detected temperature is below 63°C after 40seconds since the side heater of drain sensor has turned on. <p>② When condition which the outdoor unit is stopped forcibly consists, or the drain sensor detects continuously to go under water 5 times, and also detects "[liquid pipe temperature-suction temperature]$\leq -10^{\circ}\text{deg}$" for 30minutes continuously, the indoor unit stops abnormally (however, fan operates by normal control) that indoor unit and excluding [Fan mode or OFF] in same refrigerant system. Also, the outdoor unit which is connected to that indoor unit with refrigerant system stops abnormality (compressor is inhibited to operation). In this time, <2502> is displayed.</p>	<ol style="list-style-type: none"> 1) Drain pump trouble 2) Drain defective <ul style="list-style-type: none"> · Drain pump clogging · Drain pipe clogging 3) Open circuit of drain sensor side heater 4) Contact failure of drain sensor connector 5) Dew condensation on drain sensor <ul style="list-style-type: none"> · Drain water descends along lead wire. · Drain water waving due to filter clogging. 6) Indoor controller board defective <ul style="list-style-type: none"> · Drain pump drive circuit failure · Drain heater output circuit failure 7) Both of above mentioned 1)~6) and the indoor linear expansion valve full-closed failure (leakage) happens synchronistically. 	<p>Check the drain pump. Performance</p> <p>Please confirm whether water can be drained.</p> <p>Confirm the resistance of the drain sensor side heater. (approx. 82Ω at normal between connector CN50 1 and 3 in the indoor controller board)</p> <p>Check the connector contact failure.</p> <p>① Check the drain sensor lead- wire mounted.</p> <p>② Check the filter clogging</p> <p>If the above mentioned checkpoints has any problem, replace the indoor controller board.</p> <p>Check whether the indoor linear expansion valve leaks or not.</p>

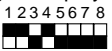

Display	Meaning and detecting method	Causes	Check points
2502	<p>Drain pump abnormality</p> <p>(Note) Address/Attribute displayed on the remote controller shows the indoor unit which is cause of trouble.</p> <p><Detected timing> Always detecting regardless of the indoor unit status.</p> <p><Abnormality clear> Abnormality is cleared by either of two of the following; <ul style="list-style-type: none"> Reset power supply of the indoor unit and outdoor unit in same refrigerant system, which is the cause of trouble in the refrigerant system. Reset power supply of the indoor unit, which is the cause of trouble. (However, power supply interception of 10 minutes or more is necessary.) </p> <p>(Note) Above ① and ② detects independently.</p>		
2503	<p>Drain sensor (THd, DS) abnormality</p> <p>When the drain sensor detects short/open while the operation.</p> <p>Short: detection of 90°C or more</p> <p>Open: detection of -40°C or less</p>	<p>1) Connector (CN50) contact failure (insertion failure)</p> <p>2) Thermistor wiring disconnection or half disconnection</p> <p>3) Thermistor defective</p> <p>4) Indoor controller board (detecting circuit) failure</p>	<p>① Check whether the indoor controller board connector (CN50) is disconnected or not.</p> <p>② Check whether the thermistor wiring is disconnected or not.</p> <p>③ Check the resistance of thermistor. 0°C...15kΩ 10°C...9.6 kΩ 20°C...6.3 kΩ 30°C...4.3 kΩ 40°C...3.0 kΩ</p> <p>④ If abnormality is not found in the method of the above-mentioned from ① to ③, it is defective of the indoor controller board.</p>
4115	<p>Power supply synchronous signal abnormality</p> <p>① When power supply synchronous signal (once a second) is not read, stop the compressor and restarts operation in 3 minutes. (When the synchronous signal is not read at just before of compressor start, the compressor does not start and stops operation 3 minutes.)</p> <p>② For 30minutes after the compressor stop (PUMY-P125VMA PUMY-P125VMA₁ : 4minutes), it is being to delay abnormal stop. Then, when SW1 is set, the outdoor units address No. and check code <4165> blinks on the 4 digit digital display alternately.</p> <p>SW1 setting on </p> <p>③ When power supply synchronous signal (once a second) is not read again during abnormal delay, the compressor stops abnormally. Then, the outdoor units address No. and check code <4115> blinks on the 4 digit digital display alternately.</p>	<p>1) Disconnection or contact failure by loose of connector (CN2) is connected to power supply board.</p> <p>2) Power supply synchronous detected circuit failures in the power supply board.</p> <p>3) Power supply synchronous detected circuit failure in the multi controller board.</p>	<p>Check the connector insertion.</p> <p>Replace the power supply board.</p> <p>Replace the multi controller board.</p>





Display	Meaning and detecting method	Causes	Check points
4116	<p>Fan rotational frequency abnormality (Detected only PKFY-P-VAM-A)</p> <p>① When rotational frequency of the fan is detected 180rpm or less, or 2000rpm or more (1st detection) while the indoor unit fan operation, the fan stops for 30seconds.</p> <p>② When the rotational frequency of the fan is detected 180rpm or less, or 2000rpm or more again after the fan restarts, the indoor unit stop abnormally (fan stops). In this time, <4116> is displayed.</p>	<p>1) Fan rotational frequency detecting connector (CN33) disconnection in the indoor controller board.</p> <p>2) Fan output connector (FAN1) disconnection in the indoor power board.</p> <p>3) Fan rotational frequency detecting connector (CN33) wiring breakage in the controller board or fan output connector (FAN1) breakage in the indoor power board</p> <p>4) Filter clogging</p> <p>5) Indoor fan motor trouble</p> <p>6) Fan rotational frequency detecting circuit failure in the indoor controller board or fan output circuit failure in the indoor power board.</p>	<p>① Check whether the connector (CN33) in the indoor controller board is disconnected or not.</p> <p>② Check whether the connector (FAN1) in the indoor power board is disconnected or not.</p> <p>③ Check whether the wiring is disconnected or not.</p> <p>④ Check the filter.</p> <p>⑤ Check the indoor fan motor.</p> <p>⑥ When there is no problem in the above-mentioned from ① to ⑤; (1) In the case of abnormality after the fan operation; Replace the indoor controller board. When the fan does not recover even if the indoor controller board is replaced, replace the indoor power board. (2) In the case of abnormality without fan operation, replace the indoor power board.</p>
4220	<p>PUMY-P125VMA PUMY-P125VMA1 Abnormality such as overvoltage or voltage shortage and abnormal synchronous signal to main circuit</p> <p>Abnormal if any of followings are detected during compressor operation;</p> <ul style="list-style-type: none"> • Decrease of DC bus voltage to 270V • Instantaneous decrease of DC bus voltage to 200V • Increase of DC bus voltage to 400V 	<p>1) Decrease of power supply voltage</p> <p>2) Disconnection of compressor wiring</p> <p>3) Defective 52C</p> <p>4) Disconnection or loose connection of CN52C</p> <p>5) Defective active filter module (ACTM)</p> <p>6) Defective active filter module (ACTM) drive circuit of outdoor power board</p> <p>7) Disconnection or loose connection of CNAF</p> <p>8) Defective 52C drive circuit of outdoor control board</p> <p>9) Disconnection or loose connection of CN5</p> <p>10) Disconnection or loose connection of CN2</p>	<p>① Check the facility of power supply.</p> <p>② Correct the wiring (U•V•W phase) to compressor.</p> <p>③ Replace 52C.</p> <p>④ Check CN52C wiring.</p> <p>⑤ Replace active filter module (ACTM).</p> <p>⑥ Replace outdoor power board.</p> <p>⑦ Check CNAF wiring.</p> <p>⑧ Replace outdoor controller board.</p> <p>⑨ Check CN5 wiring.</p> <p>⑩ Check CN2 wiring.</p>

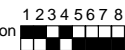
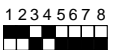

Display	Meaning and detecting method	Causes	Check points						
4220	<p>PUMY-P125YMA PUMY-P125YMA₁ Shortage abnormality of inverter bus-bar voltage</p> <p>① When direct current bus-bar voltage reduces extremely during the compressor operation, the compressor stops and restarts operation in 3minutes.</p> <p>② It is being delay to stop abnormally for 30 minutes after the compressor stop. Then, when SW1 is set, the outdoor unit address No. and check code <4320> blinks alternately on the 4 digit digital display. SW1 setting </p> <p>③ When detecting abnormality of direct bus-bar voltage decrease again during being delay abnormality, it performs the same action as ①. Also, when the abnormality is not detected, it operates normally. Hereafter, action ① is repeated until 5th abnormal detection.</p> <p>④ When the 6th voltage decrease of direct bus bar is detected during being delay abnormality, it stops abnormally. In this time, the outdoor unit address No. and check code <4220> blinks alternately on the 4 digit digital display.</p>	<p>1) Power supply terminal voltage is low.</p> <p>2) Power supply L2,L3-phase is opened.</p> <p>3) Diode stack (Diode module) defective.</p> <p>4) Connector lead wire disconnection, contact failure.</p> <p>Power supply board connecting connector (CND)-Between smoothing capacitor (CB1 and CB2).</p> <p>Power supply board connecting connector (52C)-Between electron-magnetic contactor (52C)</p> <p>5) Connector (CN2) disconnection, contact failure.</p> <p>6) Instant power failure</p> <p>7) Lightening surge, single interruption by external noise.</p> <p>8) Direct bus-bar voltage shortage detecting circuit failure in power supply board</p>	<p>Measure the terminal voltage, and check whether the voltage decreases or not.</p> <p>Check the power supply is opened.</p> <p>Check the resistance of diode stack.</p> <p>Check the defective points.</p> <p>Check the connector insertion.</p> <p>It happens by accident, and does not have the possibility to happen again.</p> <p>It happens by accident, and does not have the possibility to happen again.</p> <p>Replace the power supply board.</p>						
4230	<p>Radiator panel shield temperature</p> <p>① When the radiator panel temperature thermistor (THHS(A/B)) detects abnormality (1w detection) stops the outdoor unit once and restarts operation in 3minutes.</p> <p>② It is being delay to stop abnormally for 30minutes after the compressor stop. (PUMY-P125VMA PUMY-P125VMA₁ : 10 minutes) Then, when SW1 is set, outdoor unit address No. and check delay code <4330> blinks alternately on the 4 digit digital display. SW1 setting </p> <p>③ When the radiation shield temperature thermistor (THHS(A/B)) detects abnormality again (2nd detection) during delay abnormality, perform the same action as ①.</p> <p>④ When the radiation shield temperature thermistor (THHS(A/B)) detects abnormality on 3rd time during delay abnormality, it stops abnormally. (PUMY-P125VMA PUMY-P125VMA₁ : 5 minutes) Then, the outdoor unit address No. check code <4230> blinks alternately on the 4 digit digital display.</p> <p>Abnormality detecting temperature in radiation shield temperature thermistor</p> <table border="1"> <thead> <tr> <th>Type</th> <th>Abnormal temperature (°C)</th> </tr> </thead> <tbody> <tr> <td>125VMA/VMA₁</td> <td>85</td> </tr> <tr> <td>125YMA/YMA₁</td> <td>84</td> </tr> </tbody> </table>	Type	Abnormal temperature (°C)	125VMA/VMA ₁	85	125YMA/YMA ₁	84	<p>1) Outdoor fan motor lock</p> <p>2) Outdoor fan motor trouble</p> <p>3) Block of duct which cooled air passes</p> <p>4) Surrounding temperature-rise</p> <p>5) Thermistor failure</p> <p>6) Thermistor input circuit failure in the multi controller board</p>	<p>Check the outdoor fan motor.</p> <p>Check the outdoor fan motor.</p> <p>Check whether the air duct for cooling is opened.</p> <p>Check whether there is a heat source in surroundings of the outdoor unit. (Surroundings temperature upper limit is 46°C)</p> <p>① Check the resistance of thermistor. (Use tester)</p> <p>② Change the SW1 to on and check the temperature in radiation shield temperature thermistor. When there is a big difference between the detected temp. and thermistor temp. replace the multi controller board.</p>
Type	Abnormal temperature (°C)								
125VMA/VMA ₁	85								
125YMA/YMA ₁	84								

Display	Meaning and detecting method	Causes	Check points
4250	<p>IPM abnormality Over current limited</p> <p>(When the compressor is interrupted by over current at its start-up.)</p> <p>① When over current limit is detected within 30seconds from start-up, the compressor stops and restarts in 3minutes.</p> <p>② While the compressor stops for 3minutes, confine the current-carry.</p> <p>③ When SW1 setting during delay of interruption abnormality stop, the outdoor unit address No. and check delay code <4350> blinks alternately on the 4 digit digital display.</p> <p>SW1 setting on </p> <p>④ When the compressor is interrupted again by over current after restarting in 3minutes, it stops and restarts in 3minutes. Perform the same action as ② and ③.</p> <p>⑤ When the compressor is not interrupted within 30seconds after restarting in 3minutes, clear the delay of limited abnormal stop and back to normal.</p> <p>⑥ When the above action ④ is repeated and the compressor is interrupted within 30seconds after 7th start-up (PUMY-P125VMA PUMY-P125VMA₁: after 15th start-up), or the compressor is interrupted during confined the current-carry, it stops abnormally. Then, the outdoor unit address No. and check delay code <4250> blinks alternately on the 4 digit digital display.</p> <p>(When the compressor is interrupted by over current during the operation)</p> <p>① When over current limit is detected after 30seconds from start-up, the compressor stops and restarts in 3minutes.</p> <p>② The compressor is being delay to stop abnormally for 5minutes after the compressor stop. (PUMY-P125VMA PUMY-P125VMA₁ : 6minutes) Then, the outdoor unit address No. and check delay code <4350> blinks alternately on the 4 digit digital display.</p> <p>SW1 setting on </p> <p>③ When the compressor is interrupted again within 2minutes after restarting in 3minutes, it stops abnormally. Then, the outdoor unit address No. and check delay code <4250> blinks alternately on the 4 digit digital display. PUMY-P125VMA PUMY-P125VMA₁ : 6minutes, 4minutes.</p> <p>④ When the compressor is not interrupted within 2minutes (PUMY-P125VMA PUMY-P125VMA₁ : 3minutes) after restarting in 3minutes, it becomes the 1st detection and performs the same action as ① and ②.</p>	<p>PUMY-P125YMA PUMY-P125YMA₁</p> <p>1) Single interruption by external noise.</p> <p>2) Single interruption by lightening surge</p> <p>3) Power supply abnormality (a) Voltage decrease to 340V or less. (b) Power supply open-phase (Current increase in the compressor by the voltage decrease)</p> <p>4) Diode stack defective When it is opened-phase, same phenomenon occurs as power supply open-phase.</p> <p>5) Disconnection of connector and lead wire, and miss-wiring Between multi controller board (CN4) and power supply board (CN4)</p> <p>6) IPM (intelligent power module) drive circuit in the gate amplifier defective</p> <p>7) IPM (intelligent power module) drive signal output circuit defective, power factor detecting circuit failure in the multi controller board.</p> <p>8) Current detection defective (ACCT)</p> <p>9) Compressor lock</p> <p>10) Liquid sealing start-up of the compressor</p> <p>11) Open-phase at the compressor side</p> <p>12) IPM (intelligent power module) failure</p> <p>13) Power supply board abnormality detecting circuit failure and IPM drive power supply circuit failure</p>	<p>The interruption happens by accident. Since the interception only once returns automatically after restarting in 3minutes, the possibility to stop abnormally is very few.</p> <p>① Measure a receiving voltage and check the power supply capacity</p> <p>② Check whether the phase is opened or not. Check from 4) to 13) by following procedure;</p> <p>③ Start-up the compressor and check the status of interrupting. (1) When the compressor stops (output signal stop) after immediately after output signal comes out and is interrupted abnormally. ⇒Generation of short-circuit current is assumed. (5),6),7),12),13)) (2) After 5seconds of start-up, when the compressor stops by interruption, being delay and repeats to confine current-carry for 3minutes → restart-up → interruption → to confine current-carry → restart-up and becomes interruption-abnormality after approx. 18minutes from start-up. ⇒The compressor is assumed not to start-up by torque shortage or lock. (5), 6), 7), 9), 10), 11), 12)) (3) When the compressor stops after a while by the interception though the compressor starts once, and restarts in 3minutes. ⇒It is presumed to stop since the frequency goes up and the load grows though the compressor starts. (4), 5), 6), 7), 8))</p> <p>④ Check the miss-wiring, terminal loosing and disconnection of connector and lead wire. ⇒ Repair of defective points. (5), 11))</p> <p>⑤ Check the resistance of IPM. ⇒ In the case of abnormality, replace the gate ampere board and IPM.</p> <p>⑥ Check the resistance of diode stack. ⇒In the case of abnormality, replace the diode stack.</p> <p>⑦ When excluding of ④⑤⑥, Switch off and disconnect the connection of the compressor after confirming charge of main circuit electrolysis capacitor is discharged enough. Then, switch on and operate in no-load. (1) When the compressor is interrupted again. ⇒ Replace the power supply board when the compressor does not back to normal even if the gate amplifier board is replaced. ⇒ Replace the multi controller board when the compressor does not back to normal even if the power supply board is replaced. (2) Check the balance of inverter output voltage. If it is unbalanced,... ⇒ Replace the power supply board when the compressor does not back to normal even if the gate ampere is replaced. ⇒ Replace the multi controller board when the compressor does not back to normal even if the power supply board is replaced.</p>

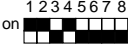

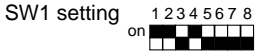
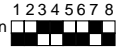

From the preceding page.

Display	Meaning and detecting method	Causes	Check points
4250			<p>⑧ When not applying from ④ to ⑦, it applies to 9) and 10). ⇒ Check the compressor. ⇒ In case of 10), recheck the compressor again after 12 hours with former power supply.</p>
		<p>PUMY-P125VMA PUMY-125VMA₁ 1) Stop valve of outdoor unit is closed. 2) Decrease of power supply voltage 3) Looseness, disconnection or converse of compressor wiring connection 4) Defective fan of indoor/outdoor units 5) Short cycle of indoor/outdoor units 6) Defective input circuit of outdoor controller board 7) Defective compressor</p>	<p>① Open stop valve. ② Check facility of power supply. ③ Correct the wiring (U•V•W phase) to compressor. ④ Check indoor/outdoor fan. ⑤ Solve short cycle. ⑥ Replace outdoor controller board. ⑦ Check compressor.</p>
5101	<p>Suction temperature thermistor (TH21) abnormality When controller detects short (high temp.)/open (low temp.) in thermistor during the operation, the operation stops and the operation changes to protect mode of restarting in 3minutes. If the thermistor does not recover in 3minutes, the operation stops abnormally. In this time, <5101> is displayed. Then, if the thermistor recover in 3minutes, it operates normally.</p> <p>Short: Detected 90℃ or more Open: Detected —40℃ or less</p>	<p>1) Connector (CN20) contact failure 2) Thermistor wiring disconnection or half disconnection 3) Thermistor failure 4) Detecting circuit failure in the indoor controller board</p>	<p>① Check whether the connector (CN20) in the indoor controller board is connected or not. ② Check whether the thermistor wiring is disconnected or not. ③ Check the resistance of thermistor; 0℃...15kΩ 10℃...9.6kΩ 20℃...6.3kΩ 30℃...4.3kΩ 40℃...3.0kΩ ④ When there is no problem in above mentioned ①②③, replace the indoor controller board.</p>
	<p>Discharge temperature thermistor (TH1) abnormality</p> <p>① When controller detects short/open in thermistor during the operation, the outdoor unit stops once and restarts operation in 3minutes. When the detected temperature is normal at just before of restarting, the outdoor unit restarts.</p> <p>② When controller detects short/open in thermistor at just before of restarting, the unit stops abnormally. In this time, <5101> is displayed.</p> <p>③ While the compressor is protected not to restart in 3minutes, the unit is delayed abnormal stop. Then, the outdoor unit address No. and check delay code <1202> blinks alternately on the 4 digit digital display. SW1 setting </p> <p>④ For 10 minutes after starting compressor, for defrosting or for 3minutes after recover of defrosting, above-mentioned short/open are not detected. Short: 216℃ or more (1kΩ) Open: 0℃ or less (700kΩ) Note) When outer temperature thermistor (TH6) is 5℃ or less on cooling, open detecting is not determined as abnormality.</p>	<p>1) Connector (TH1) contact failure 2) Thermistor wiring disconnection or half disconnection 3) Thermistor failure 4) Multi controller board input circuit failure</p>	<p>① Check whether the connector (TH1) in the multi controller board is connected or not. ② Check whether the thermistor wiring is disconnected or not. ③ Check the resistance of thermistor; When the resistance is not below value, replace the thermistor. 0℃... about 700kΩ 10℃... about 410kΩ 20℃... about 250kΩ 30℃... about 160kΩ 40℃... about 104kΩ ④ Set the SW1 to  When the temperature in multi controller board is not an actual temperature, replace the multi controller board. -99.9: Open 999.9: Short</p>

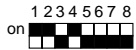
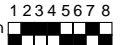
Display	Meaning and detecting method	Causes	Check points
5102	<p>Liquid pipe temperature thermistor (TH22) abnormality</p> <p>When the thermistor detects short/open during the operation, the operation stops and the operation changes to protect mode of restarting in 3minutes. If the thermistor does not recover in 3minutes, the operation stops abnormally. In this time, <5102> is displayed. Then, if the thermistor recover in 3minutes, it operates normally.</p> <p>Short: Detected 90℃ or more Open: Detected -40℃ or less</p>	<p>1) Connector (CN21) contact failure</p> <p>2) Thermistor wiring disconnection or half disconnection</p> <p>3) Thermistor failure</p> <p>4) Detecting circuit failure in the indoor controller board</p>	<p>① Check whether the connector (CN21) in the indoor controller board is connected or not.</p> <p>② Check whether the thermistor wiring is disconnected or not.</p> <p>③ Check the resistance of thermistor; 0℃...15kΩ 10℃...9.6kΩ 20℃...6.3kΩ 30℃...4.3kΩ 40℃...3.0kΩ</p> <p>④ When there is no problem in above mentioned ①②③,replace the indoor controller board.</p>
	<p>Low pressure saturation temperature thermistor (TH2) abnormality</p> <p>① When controller detects short/open in thermistor during the operation, the outdoor unit stops once and restarts operation in 3minutes. When the detected temperature is normal at just before of restarting, the outdoor unit restarts.</p> <p>② When controller detects short/open in thermistor at just before of restarting, the unit stops abnormally. In this time, <5102> is displayed.</p> <p>③ While the compressor is protected not to restart in 3minutes, the unit is delayed abnormal stop. Then, the outdoor unit address No. and check delay code <1211> blinks alternately on the 4 digit digital display.</p> <p>SW1 setting </p> <p>④ For 10 minutes after starting compressor, for defrosting or for 3minutes after recover of defrosting, above-mentioned short/open are not detected.</p> <p>Short: 100℃ or more (0.5kΩ) Open: -46℃ or less (200kΩ)</p>	<p>1) Connector (TH2) contact failure</p> <p>2) Thermistor wiring disconnection or half disconnection</p> <p>3) Thermistor failure</p> <p>4) Multi controller board input circuit failure</p>	<p>① Check whether the connector (TH2) in the multi controller board is connected or not.</p> <p>② Check whether the thermistor wiring is disconnected or not.</p> <p>③ Check the resistance of thermistor; 0℃...15kΩ 10℃...9.6kΩ 20℃...6.3kΩ 30℃...4.3kΩ 40℃...3.0kΩ</p> <p>④ Set the SW1 to  When the temperature in multi controller board is not an actual temperature, replace the multi controller board. -99.9: Open 999.9: Short</p>

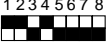

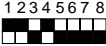
Display	Meaning and detecting method	Causes	Check points
5103	<p>Gas pipe temperature thermistor (TH23) abnormality</p> <p>When the thermistor detects short/open after 3minutes-continuous thermo ON during cooling or dry operation, the operation stops and the operation changes to protect mode of restarting in 3minutes. If the thermistor does not recover in 3minutes, the the operation stops abnormally. In this time, <5103> is displayed. Then, if the thermistor recover in 3minutes, it operates normally.</p> <p>Short: Detected 90℃ or more</p> <p>Open: Detected -40℃ or less</p>	<p>1) Connector (CN29) contact failure</p> <p>2) Thermistor wiring disconnection or half disconnection</p> <p>3) Thermistor failure</p> <p>4) Detecting circuit failure in the indoor controller board</p>	<p>① Check whether the connector (CN29) in the indoor controller board is connected or not.</p> <p>② Check whether the thermistor wiring is disconnected or not.</p> <p>③ Check the resistance of thermistor;</p> <p>0℃...15kΩ 10℃...9.6kΩ 20℃...6.3kΩ 30℃...4.3kΩ 40℃...3.0kΩ</p> <p>④ When there is no problem in above mentioned ①②③,replace the indoor controller board.</p>
5105	<p>Pipe temperature / judging defrost thermistor (TH5) abnormality</p> <p>① When controller detects short/open in thermistor during the operation, the outdoor unit stops once and restarts operation in 3minutes. When the detected temperature is normal at just before of restarting, the outdoor unit restarts.</p> <p>② When controller detects short/open in thermistor at just before of restarting, the unit stops abnormally. In this time, <5105> is displayed.</p> <p>③ While the compressor is protected not to restart in 3minutes, the unit is delayed abnormal stop. Then, the outdoor unit address No. and check delay code <1205> blinks alternately on the 4 digit digital display.</p> <p>SW1 setting </p> <p>④ For 10 minutes after starting compressor, for defrosting or for 3minutes after recover of defrosting, above-mentioned short/open are not detected.</p> <p>Short: 88℃ or more (0.4kΩ) Open: -39℃ or less (115kΩ)</p>	<p>1) Connector (TH5) contact failure</p> <p>2) Thermistor wiring disconnection or half disconnection</p> <p>3) Thermistor failure</p> <p>4) Multi controller board input circuit failure</p>	<p>① Check whether the connector (TH5) in the multi controller board is connected or not.</p> <p>② Check whether the thermistor wiring is disconnected or not.</p> <p>③ Check the resistance of thermistor; When the resistance is not below value, replace the thermistor.</p> <p>0℃...15kΩ 10℃...9.6kΩ 20℃...6.3kΩ 30℃...4.3kΩ 40℃...3.0kΩ</p> <p>④ Set the SW1 to  When the temperature in multi controller board is not an actual temperature, replace the multi controller board.</p> <p>-99.9: Open 999.9: Short</p>

Display	Meaning and detecting method	Causes	Check points
5106	<p>Outdoor temperature thermistor (TH6) abnormality</p> <p>① When controller detects short/open in thermistor during the operation, the outdoor unit stops once and restarts operation in 3minutes. When the detected temperature is normal at just before of restarting, the outdoor unit restarts.</p> <p>② When controller detects short/open in thermistor at just before of restarting, the unit stops abnormally. In this time, <5106> is displayed.</p> <p>③ While the compressor is protected not to restart in 3minutes, the unit is delayed abnormal stop. Then, the outdoor unit address No. and check delay code <1221> blinks alternately on the 4 digit digital display.</p> <p>SW1 setting on </p> <p>④ For 10 minutes after starting compressor, for defrosting or for 3minutes after recover of defrosting, above-mentioned short/open are not detected.</p> <p>Short: 88℃ or more (0.4kΩ) Open: -39℃ or less (115kΩ)</p>	<p>1) Connector (TH6) contact failure</p> <p>2) Thermistor wiring disconnection or half disconnection</p> <p>3) Thermistor failure</p> <p>4) Multi controller board input circuit failure</p>	<p>① Check whether the connector (TH6) in the multi controller board is connected or not.</p> <p>② Check whether the thermistor wiring is disconnected or not.</p> <p>③ Check the resistance of thermistor; When the resistance is not below value, replace the thermistor.</p> <p>0℃...15kΩ 10℃...9.6kΩ 20℃...6.3kΩ 30℃...4.3kΩ 40℃...3.0kΩ</p> <p>④ Set the SW1 to on  When the temperature in multi controller board is not an actual temperature, replace the multi controller board.</p> <p>-99.9: Open 999.9: Short</p>
5110	<p>PUMY-P125VMA, PUMY-P125VMA₁: Radiator panel temperature thermistor (THHS-A, THHS-B) abnormality</p> <p>PUMY-P125YMA, PUMY-P125YMA₁: IPM radiator panel temperature thermistor (THHS) abnormality</p> <p>① When controller detects short/open in thermistor during the operation, the outdoor unit stops once and restarts operation in 3minutes. When the detected temperature is normal at just before of restarting, the outdoor unit restarts.</p> <p>② When controller detects short/open in thermistor at just before of restarting, the unit stops abnormally. In this time, <5110> is displayed.</p> <p>③ While the compressor is protected not to restart in 3minutes, the unit is delayed abnormal stop. Then, the outdoor unit address No. and check delay code <1214> blinks alternately on the 4 digit digital display.</p> <p>SW1 setting on </p> <p>④ For 10 minutes after starting compressor, for defrosting or for 3minutes after recover of defrosting, above-mentioned short/open are not detected.</p> <p>(PUMY-P125YMA, PUMY-P125YMA₁)</p> <p>PUMY-P125VMA, PUMY-P125VMA₁: Short: 102℃ or more (2.9kΩ) Open: -27℃ or less (950kΩ)</p> <p>PUMY-P125YMA, PUMY-P125YMA₁: Short: 132℃ or more (1.2kΩ) Open: -30℃ or less (1200kΩ)</p>	<p>1) Connector (THHS(A/B)) contact failure</p> <p>2) Thermistor wiring disconnection or half disconnection</p> <p>3) Thermistor failure</p> <p>4) Multi controller board input circuit failure</p>	<p>① Check whether the connector (THHS(A/B)) in the multi controller board is connected or not.</p> <p>② Check whether the thermistor wiring is disconnected or not.</p> <p>③ Check the resistance of thermistor; When the resistance is not below value, replace the thermistor.</p> <p>0℃...180kΩ 10℃...105kΩ 20℃...63kΩ 30℃...39kΩ 40℃...25kΩ</p> <p>④ Set the SW1 to on  When the temperature in multi controller board is not an actual temperature, replace the multi controller board.</p> <p>-99.9: Open 999.9: Short</p>

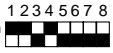

Display	Meaning and detecting method	Causes	Check points
5201	<p>Pressure sensor (63HS) abnormality</p> <p>① When detected pressure in high-pressure pressure sensor is 1MPa or less during the operation, the compressor stops and restarts operation in 3minutes.</p> <p>② When the detected pressure is 1MPa or less at just before of restarting, the compressor stops abnormally. In this time, <5201> is displayed.</p> <p>③ For 3minutes after the compressor stops, the unit delays to abnormal stop. Then, the outdoor unit address No. and check delay code <1402> blinks alternately on the 4digit digital display.</p> <p>SW1 setting  on</p> <p>④ For 3minutes after starting compressor, for defrosting or for 3minutes after recover of defrosting, abnormality is not determined as abnormality.</p>	<p>1) High-pressure pressure sensor failure</p> <p>2) Internal pressure decrease by gas leakage</p> <p>3) Connector contact failure, disconnection</p> <p>4) Multi controller board input circuit failure</p>	<p>① Check the high-pressure pressure sensor.</p> <p>② Check the internal pressure.</p> <p>③ Check the high-pressure pressure sensor.</p> <p>④ Check the high-pressure pressure sensor.</p>
5300	<p>Current sensor error (PUMY-P125VMA PUMY-P125VMA₁)</p> <p>① Abnormal if current sensor detects -1.5A to 1.5A during compressor operation. (This error is ignored in case of SW6-3 ON.)</p> <p>② 1. When input current sensor on N.F. circuit board detects 34A or more, compressor stops and restarts in 3 minutes. 2. When the sensor detects 34A or more again (2nd detection) within 10 minutes, since the compressor has stopped, the compressor stops again and restarts operation in 3 minutes. 3. When the sensor detects 34A or more again (10th detection) within 10 minutes, it stops abnormally. In this time <5300> error is displayed. 4. It is being delay for abnormal stop during 10 minutes since the compressor has stopped. In this time, check delay code <5350> will be displayed.</p>	<p>1) Disconnection of compressor wiring</p> <p>2) Defective circuit of current sensor on outdoor power board</p> <p>3) Low voltage supplied to power supply terminal block.</p>	<p>① Correct the wiring (U•V•W phase) to compressor.</p> <p>② Replace outdoor power board.</p> <p>③ Check the facility of power supply.</p>
6600	<p>Duplex address error</p> <p>Detected error when transmission of unit with the same address is confirmed,</p> <p>Note) Address/Attribute displayed on the remote controller shows the controller detecting abnormality.</p>	<p>1) There are 2units or more with the same address among the outdoor unit or indoor unit or lossnay controller, remote controller.</p> <p>2) When noise has occurred in the transmission signal, and the signal has changed.</p>	<p>① Look for the unit, which is source of abnormality with the same address. When the same address is found, correct the address and turn off power supply of outdoor unit, indoor unit, and lossnay for 2minutes or more as the same time. Then, turn on power supply.</p> <p>② Check the transmitted wave and the noise on the transmission line.</p>
6602	<p>Transmission processor H/W error</p> <p>" 1 " shows on the transmission line though the transmission processor transmitted " 0".</p> <p>Note) Address/Attribute displayed on the remote controller shows the controller detecting abnormality.</p>	<p>1) When the wiring for either of the indoor unit, the outdoor unit or lossnay transmission line is constructed or polarity is changed with the power supply turned on, the transmission waves change in case that the transmission data collides mutually. It causes to detect error.</p> <p>2) Transmission processor circuit failure</p> <p>3) When the transmission data has changed by the noise.</p>	<p>① When the transmission line is constructed with the current flowed, turn off power supply of outdoor unit, indoor unit and lossnay for 2minutes or more as the same time. Then, turn on power supply.</p> <p>② Check the transmitted wave and the noise on the transmission line.</p>



Display	Meaning and detecting method	Causes	Check points
6603	<p>Transmission bus busy error</p> <p>① Over error by collision</p> <p>Abnormality when the state, which cannot be transmitted by collision of transmission, is consecutive for 8 to 10minutes.</p> <p>② The state that data cannot to be output to the transmission line by the noise happens for 8 to 10minutes consecutively.</p> <p>Note) Address/Attribute displayed on the remote controller shows the controller detecting abnormality.</p>	<p>1) The transmission processor cannot be transmitted since a short cycle voltage of the noise etc. mixes on the transmission line consecutively.</p> <p>2) The transmission volume increases and cannot be transmitted since the wiring method is mistaken and the routing technique to the terminal board (TB3) for the transmission line of the outdoor unit and the terminal board (TB7) for centralized control cannot be transmitted.</p> <p>3) The share becomes high since the data exists together to other transmitted data by a defective repeater (function which connects and intercepts the transmission of controlling system and centralized control system), and it causes abnormal detection.</p>	<p>① Check whether the transmission line of the indoor unit, fresh master, lossnay and remote controller is connected to the outdoor unit terminal board (TB7) for centralized controller or not.</p> <p>② Check whether the transmission line with the other refrigerant system of the indoor unit and lossnay is connected to the outdoor unit terminal board (TB3) for transmission or not.</p> <p>③ Check whether the outdoor unit terminal board for transmission line (TB3) and for centralized controller (TB7) are connected or not.</p> <p>④ Check the transmitted wave and the noise on the transmission line.</p>
6606	<p>Signal communication error with transmission processor</p> <p>Signal communication error between unit processor and transmission processor</p> <p>Note) Address/Attribute displayed on the remote controller shows the controller detecting abnormality.</p>	<p>1) It happened since the noise and lightening serge that happened by chance had not normally transmitted the data of the unit/transmission processor.</p> <p>2) The address transmission from the unit processor was not normally transmitted by the hardware of transmission processor defective.</p>	<p>Turn off power supply of outdoor unit, indoor unit, and lossnay for 2minutes or more at the same time. Then, turn on power supply. It recovers normally at the malfunction that happens by chance. When same abnormality occurs again, it is defective of a generation former controller.</p>

Display	Meaning and detecting method	Causes	Check points
6607	<p>No ACK (Acknowledgement)</p> <p>① Abnormality which controller of the sending side detects when there is no answer (ACK) from other side though data was transmitted once. It is detected 6 times every 30seconds continuously.</p> <div style="border: 1px solid black; padding: 5px; margin-top: 10px;"> <p>Note) Address/Attribute displayed on the remote controller shows the controller, which did not send back replay (ACK).</p> </div>	<p>Factor that not related to origin</p> <p>1) Since the address switch was changed with the current passed, the unit in the last address does not exist.</p> <p>2) Decline of transmission voltage and signal by transmission line tolerance over · The furthest point...200m · Remote controller line...(12m) (See page 26-33 for details)</p> <p>3) Decline of transmission line voltage and signal by unmatched kind of line. Kind...Shield line-CVVS,CPEVS No shield...VCTF, VCTFK, CVV, CVS, VVR, VVF, VCT Line diameter...1.25 mm² or more</p> <p>4) Decline of transmission line voltage and signal by a number of over-connected units.</p> <p>5) Miss operation of origin controller, which happens by chance.</p> <p>6) Origin controller defective</p>	<p>① Turn off power supply of outdoor unit, indoor unit fresh master and lossnay for 2minutes or more at the same time. Then, turn on power supply. It recovers normally at the malfunction that happens by chance.</p> <p>② Check the address switch in the address, which occurs abnormality.</p> <p>③ Check whether the transmission line is connected / loosen or not at origin. (Terminal board or connector)</p> <p>④ Check whether the transmission line tolerance is over or not.</p> <p>⑤ Check whether the kind of transmission line is mistaken or not.</p> <p>When there is any trouble from above ①-⑤, turn off power supply of outdoor unit, indoor unit and lossnay for 2minutes or more at the same time. Then, turn on power supply.</p> <p>⇒When there is not any trouble in single refrigerant system (1outdoor unit) from above①-⑤, controller defective in displayed address and attribute. ⇒ When there is not any trouble in different refrigerant system (2outdoor unit or more) from above①-⑤, determine it after ⑥.</p> <p>⑥ When the address, which should not exist, is an origin, since there is the indoor unit which memorizes the address data, cancel the unnecessary address data by the manual setting function of remote controller. However, they are limited to the system, which sets the group between different refrigerant systems, or which fresh master /lossnay are connected.</p> <p>When there is not any trouble from above ①-⑥, replace the displayed address/attribute controller board.</p> <p>In this time, when the error does not recover to normal, the outdoor unit multi controller board (repeater circuit) defective is expected.</p> <p>Check the recovery by replacing the multi controller board one by one.</p>
	<p>1) When the cause of displayed address and attribute is on the outdoor unit side (The indoor unit detects when there is no reply (ACK) on transmitting from the indoor unit to the outdoor unit.)</p>	<p>1) Contact failure of outdoor unit or indoor unit transmission line</p> <p>2) Indoor unit transmission connector (CN2M) disconnection</p> <p>3) Sending/receiving signal circuit failure in the indoor/outdoor unit</p>	
	<p>2) When the cause of displayed address and attribute is on the indoor unit side</p> <p>(The remote controller detects when there is no reply (ACK) on transmitting from the remote controller to the indoor unit.)</p>	<p>1) When operating with multi refrigerant system indoor units, the remote controller transmits the signal to the indoor unit after the other refrigerant system outdoor unit is turned off or turned on again in 2minutes, and detects abnormality.</p> <p>2) Contact failure of remote controller or indoor unit transmission line.</p> <p>3) Indoor unit transmission connector (CN2M) disconnection.</p> <p>4) Sending/receiving signal circuit failure in the indoor unit or remote controller.</p>	



Display	Meaning and detecting method	Causes	Check points
6607	<p>3) When the cause of displayed address and attribute is on the remote controller side</p> <p>(The indoor unit detects when there is no reply (ACK) on transmitting from the indoor unit to the remote controller unit.)</p>	<p>1) When operating with multi refrigerant system indoor units, the indoor units transmits the signal to the remote controller after the other refrigerant system outdoor unit is turned off or turned on again in 2minutes, and detects abnormality.</p> <p>2) Contact failure of remote controller or indoor unit transmission line</p> <p>3) Indoor unit transmission connector (CN2M) disconnection.</p> <p>4) Sending/receiving signal circuit failure in the indoor unit or remote controller.</p>	
	<p>4) When the cause of displayed address and attribute is on the fresh master side</p> <p>(The indoor unit detects when there is no reply (ACK) on transmitting from the indoor unit to the fresh master.)</p>	<p>1) When synchronized operating with other refrigerant system fresh master, the indoor units transmits the signal to the fresh master after the fresh master and same refrigerant system outdoor unit is turned off or turned on again in 2minutes, and detects abnormality.</p> <p>2) Contact failure of fresh master or indoor unit transmission line</p> <p>3) Indoor unit or fresh master transmission connector (CN2M) disconnection.</p> <p>4) Sending/receiving signal circuit failure in the indoor unit or fresh master.</p>	
	<p>5) When the cause of displayed address and attribute is on the lossnay side</p> <p>(The indoor unit detects when there is no reply (ACK) on transmitting from the indoor unit to the lossnay.)</p>	<p>1) When the lossnay power supply is Off, the indoor unit detects abnormality at signal transmitting to the lossnay.</p>	



Display	Meaning and detecting method	Causes	Check points
6607	<p>6) When the controller of displayed address and attribute is not recognized</p>	<p>2) When synchronized operating with other refrigerant system lossnay, the indoor units transmits the signal to the lossnay after the lossnay and same refrigerant system outdoor unit is turned off or turned on again in 2minutes, and detects abnormality</p> <p>3) Contact failure of lossnay or indoor unit transmission line</p> <p>4) Indoor unit transmission connector (CN2M) disconnection.</p> <p>5) Sending/receiving signal circuit failure in the indoor unit or lossnay.</p> <p>1) Since the address switch was changed with the current passed, the unit in the last address does not exist.</p> <p>2) Since the fresh master/lossnay address are changed after synchronized setting of fresh master / lossnay by the remote controller, abnormality is detected at transmitting from the indoor unit.</p>	
6608	<p>No response Though there was a replay (ACK) of having received signal from the other side, it is the abnormality when the response command does not return. The sending side detects the abnormality continuously six times every 30 seconds. Note) Address/Attribute displayed on the remote controller shows the controller, which did not response.</p>	<p>1) Transmission repeats the failure by the noise etc.</p> <p>2) Decline of transmission voltage and signal by transmission line tolerance over. · The furthest point...200m · Remote controller line...(12m) (See page 26-33 for details)</p> <p>3) Decline of transmission line voltage and signal by unmatched kind of line. Kind...Shield wire-CVVS,CPEVS No shield ...VCTF, VCTFK, CVV, CVS, VVR, VVF, VCT wire diameter...1.25mm² or more</p> <p>4) Miss operation of origin controller, which happens by chance.</p>	<p>① Check the transmission wave and noise on the transmission line.</p> <p>② Turn off power supply of outdoor unit, indoor unit and lossnay for 2minutes or more at the same time. Then, turn on power supply again. It recovers normally at the malfunction that happens by chance. When same abnormality occurs again, it is defective of displayed address and attribute.</p>



Display	Meaning and detecting method	Causes	Check points
6810	<p>UR communication abnormality (UR: Unit Remote controller) Communications between the unit remote controller and indoor unit is not normal.</p> <p>When there is no display of address and attribute to the remote controller. (When detecting by the unit remote controller)</p> <p>1) It is abnormality though the unit remote controller transmitted "H", when "L" reception is detected continuously three times.</p> <p>2) It is abnormality when there is no response from the indoor unit for 3 minutes against to "monitor request" from the unit remote controller.</p> <p>3) It is abnormality when there is no response 3times continuously from the indoor unit against to "operation /setting" from the unit remote controller.</p> <hr style="border-top: 1px dashed black;"/> <p>When the cause of displayed address and attribute is on the indoor unit side.</p> <p>1) It is abnormality though the indoor unit transmitted "H", when "L" reception is detected continuously three times.</p> <p>2) It is abnormality when the indoor units cannot receive the transmission signal from the unit remote controller for 3minutes.</p>	<p>1) Contact failure of the unit remote controller transmission line in the unit remote controller or indoor unit.</p> <p>2) Decline of transmission voltage and signal on the unit remote controller transmission line by the unit remote controller transmission line tolerance over</p> <p>3) When the transmission signal of unit remote controller changes by noise.</p> <p>4) Unit remote controller transmitting / receiving signal circuit failure in the unit remote controller or indoor unit.</p>	<p>① Check whether the transmission line of the indoor unit or unit remote controller is connected / loosen or not.</p> <p>② Check whether the unit remote controller transmission line tolerance is over or not.</p> <p>③ Check the transmission wave and noise on the transmission signal of unit remote controller.</p> <p>④ When there is not any trouble from above ①-③, replace the indoor controller board or unit remote controller. Check of following conditions is available by LED1/LED2 in the indoor controller board. · When LED1 and 2 blinks at the same time. The indoor unit is transmitting to the unit remote controller. · When only LED2 blinks. The unit remote controller is transmitting to the indoor unit. Or, other indoor unit is transmitting to the unit remote controller. ·When LED1 and 2 does not blink. The indoor unit and unit remote controller is not transmitting.</p>
6831 6834	<p>Signal reception abnormality (Remote controller) Following symptoms are regarded as abnormality.</p> <p>1) When the remote controller cannot receive the signal from indoor controller normally even once for 3 minutes</p> <p>2) When sub-remote controller cannot receive the signal even once for 2 minutes</p>	<p>① Defect of the transmission and reception circuit of the remote controller.</p> <p>② Defect of the transmission and reception circuit of the indoor controller board</p> <p>③ Noise occurs on the transmission line of the remote controller</p> <p>④ All remote controllers are set as sub-remote controller.</p>	<p>①-③ Perform a check of the remote controller. According to the results, perform the following disposals. • When "RC OK" is displayed The remote controller is normal. Turn off the power supply and turn it on again. If "HO" is displayed for 4 minutes or more, replace the indoor controller board. • When "RC NG" is displayed Replace the remote controller. • When "RC 6832 or 6833" or "ERC 00-66" is displayed These displays may be due to noise, etc. ④ Set one remote controller to main remote controller and the other to sub-remote controller.</p>
6832 6833	<p>Signal transmission abnormality (Remote controller) Following symptoms are regarded as abnormality.</p> <p>1) When sub-remote controller cannot transmit the signal to the transmission path for 6 seconds</p> <p>2) When the remote controller cannot finish transmitting the signal for 30 times on end</p>	<p>① Defect of the transmission and reception circuit of the remote controller</p> <p>② Noise occurs on the transmission line of the remote controller</p> <p>③ There are two main remote controllers.</p>	<p>④ Set one remote controller to main remote controller and the other to sub-remote controller.</p>

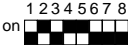
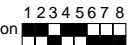
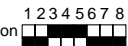
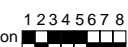
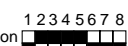
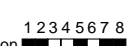
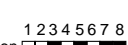
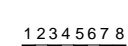

Display	Meaning and detecting method	Causes	Check points
7100	When connected total models of the indoor units exceed the specified level (130% of the outdoor unit models), error code <7100> is displayed.	1) Connecting total models of the indoor unit exceed the specified level. 125: Possible up to 163 (code 33)	① Check the total models of connected indoor unit. ② Check the model code registration switch (indoor controller board SW2) of connected indoor unit.
		2) There is a mistake in the registration of model name code of the outdoor unit.	Check the model code registration switch (outdoor multi controller board SW4) of the outdoor unit.
7101	Capacity code error When the connected indoor unit models cannot be connected, <7101> is displayed.	The indoor unit models is not possible to connect, The indoor unit of 20-125(code 4-25) is possible to connect.	① Check the model code registration switch (indoor controller board SW2) in the connected indoor unit. ② The outdoor unit SW1 operation can check model code of the connected indoor units. Code of indoor unit No.1  Code of indoor unit No.2  Code of indoor unit No.3  Code of indoor unit No.4  Code of indoor unit No.5  Code of indoor unit No.6  Code of indoor unit No.7  Code of indoor unit No.8 
7102	Number of connecting unit over When the connecting unit exceeds a number of limitations, error code <7102> is displayed. (Even if the indoor unit is not connected, becomes <7102> is display.)	Connecting unit exceeds a number of limitations. It is assumed abnormality excluding the following cases; 1) The indoor unit can be totally connected up to 8 units. The indoor unit can be connected up to 8 units 2) Ventilation unit connecting is only 1unit.	Check whether the connecting unit exceeds a number of limitations or not.
0403	Serial communication error Abnormal if serial communication between outdoor multi board and outdoor power board is defective.	① Breaking of wire or contact failure of connector CN2 ② Breaking of wire or contact failure of connector CN4 ③ Defective communication circuit of outdoor power board ④ Defective communication circuit of outdoor multi board for power board	①② Check connection of each connector CN2, CN4. ③ Replace outdoor power board. ④ Replace outdoor multi board.



Display	Meaning and detecting method	Causes	Check points
7105	Address setting error Address setting of the outdoor unit is wrong.	Addresses miss setting of the outdoor unit. The outdoor unit is not set in 000 or in the range of 51-100.	Check the address setting of the outdoor unit. The address should be set in 000 or 51-100. When the setting is out of the range, reset it, turn off power supply of the outdoor unit, indoor unit and lossnay for 2minutes or more at the same time, and turn on power supply again.
7111	Remote controller sensor abnormality In the case of network remote controller, it is an abnormality when incapable response returns from the net work remote controller during the operation.	When an old type remote controller for M-NET is used, and the remote controller sensor is specified (SW1-1 is ON).	Replace the remote controller to net work remote controller.

9-2. REMOTE CONTROLLER DIAGNOSIS

- MA remote controller is equipped with the diagnosis function.

Check the remote controller with this function when the unit does not operate with the remote controller.

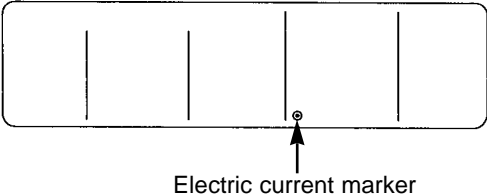
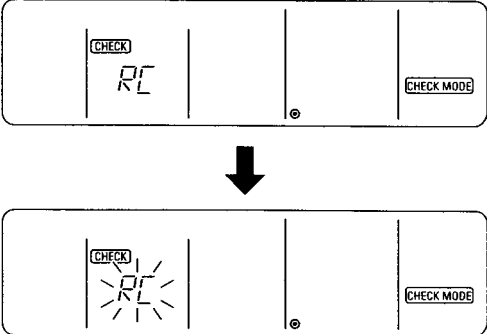
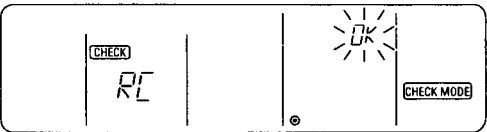
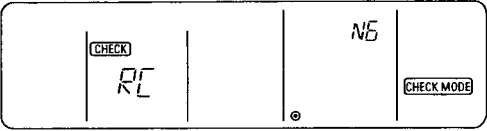
<p>(1)</p>  <p>Electric current marker</p> <p>(2)</p>  <p>(3)</p> <p>a)</p>  <p>b)</p> 	<p>(1) First, check the electricity current maker. If the correct voltage (DC 8.7~13V) is not supplied on the remote controller, the electric current marker will be lit. If the electricity current marker is not lit, check the remote controller wiring and the indoor units.</p> <p>(2) Transfer to remote control diagnosis mode. Hold down the CHECK button for five seconds or more to display the diagram on the left. Press the FILTER button to commence diagnosis of remote controller.</p> <p>(3) Remote controller diagnosis results.</p> <p>a) The remote control is functioning correctly. Check other possible causes as there are on problems with the remote controller.</p> <p>b) The remote controller has a nonconformity. The remote controller must be replaced. Error display 1 ("NG") flashes to show a nonconformity in the transmitter-receiver circuit.</p>
--	---

To be continued on the next page.

From the preceding page.

a)

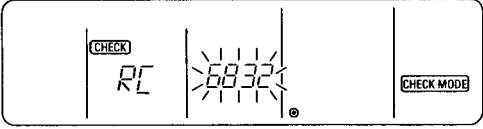

b)

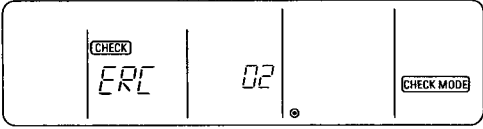

• When the number of data errors generated is 02.

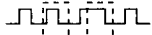
Remote controller transmission data 

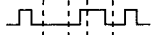
Transmission data at transmission path 

Potential problems other than those diagnosed for the remote controller.

a) Single transmission not possible if error display 2 (“6832 or 6833”) flashes. There is “noise” on the transmission line, or damage of other remote controller for the indoor units can be considered. Check the transmission path and other controller

b) Data error has occurred when error display three shows “ERC” and number of data errors. Number of generated data error (maximum 66 errors). The number of generated data error stands for the difference in the number of bits of transmitted data from the remote controller and the actual number of bits that were transmitted along the transmission path. If this error occurs, “noise”, etc., is interfering with the transmission data. Check the transmission path.

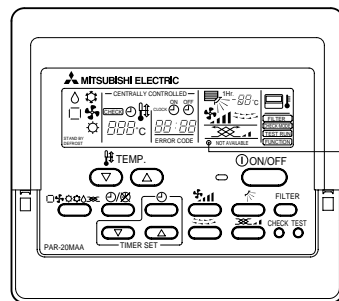

(4) **Cancel the remote controller diagnosis.**
Hold down the CHECK button for five seconds or more to cancel the remote controller diagnosis. The “HO” operation lamp will flash, and the display screen will return to the status before remote controller diagnosis in approximately 30 seconds.

9-3. REMOTE CONTROLLER TROUBLE



“” indicator: Appears when current is carried.

(1) For M-NET remote controller systems

Symptom or inspection code	Cause	Inspection method and solution
Though the content of operation is displayed on the remote controller, some indoor units do not operate.	<ul style="list-style-type: none"> The power supply of the indoor unit is not on. The address of the indoor units in same group or the remote controller is not set correctly. The group setting between outdoor units is not registered to the remote controller. The fuse on the indoor unit controller board is blown. 	<ul style="list-style-type: none"> Check the part where the abnormality occurs. <ol style="list-style-type: none"> The entire system In the entire refrigerant system In same group only One indoor unit only
Though the indoor unit operates, the display of the remote controller goes out soon.	<ul style="list-style-type: none"> The power supply of the indoor unit is not on. The fuse on the indoor unit controller board is blown. 	<p><In case of the entire system or in the entire refrigerant system></p> <ul style="list-style-type: none"> Check the self-diagnosis LED of the outdoor unit. Check the items shown in the left that are related to the outdoor unit.
() is not displayed on the remote controller. (M-NET remote controller is not fed.)	<ul style="list-style-type: none"> The power supply of the outdoor unit is not on. The number of connected indoor unit in the refrigeration system is over the limit or the number of connected remote controller is over the limit. M-NET remote controller is connected to MA remote controller cable. The transmission line of the indoor/outdoor unit is shorted or down. M-NET remote controller cable is shorted or down. 	<p><In case of in same group only or one indoor unit only></p> <ul style="list-style-type: none"> Check the items shown in the left that are related to the indoor unit.
"HO" keeps being displayed or it is displayed periodically. ("HO" is usually displayed for 3 minutes at the longest after the power supply of the outdoor unit is on.)	<ul style="list-style-type: none"> The power supply for the feeding expansion unit for the transmission line is not on. The address of the outdoor unit remains "00". The address of the indoor unit or the remote controller is not set correctly. MA remote controller is connected to the transmission line of the indoor/outdoor unit. 	
The remote controller does not operate though () is displayed.	<ul style="list-style-type: none"> The transmission line of the indoor/outdoor unit is connected to TB15. The transmission line of the indoor/outdoor unit is shorted, down or badly contacted. 	



(2) For MA remote controller systems





Symptom or inspection code	Cause	Inspection method and solution
Though the content of operation is displayed on the remote controller, some indoor units do not operate.	<ul style="list-style-type: none"> The power supply of the indoor unit is not on. Wiring between indoor units in same group is not finished. The indoor unit and Slim model are connected to same group. The fuse on the indoor unit controller board is blown. 	<ul style="list-style-type: none"> Check the part where the abnormality occurs. ① The entire system ② In the entire refrigerant system ③ In same group only ④ One indoor unit only
Though the indoor unit operates, the display of the remote controller goes out soon.	<ul style="list-style-type: none"> The power supply of the indoor unit (Master) is not on. In case of connecting the system controller, the setting of the system controller does not correspond to that of MA remote controller. The fuse on the indoor unit (Master) controller board is blown. 	<p><In case of the entire system or in the entire refrigerant system></p> <ul style="list-style-type: none"> Check the self-diagnosis LED of the outdoor unit. Check the items shown in the left that are related to the outdoor unit. <p><In case of in same group only or one indoor unit only></p> <ul style="list-style-type: none"> Check the items shown in the left that are related to the indoor unit.
(●) is not displayed on the remote controller. (MA remote controller is not fed.)	<p>The remote controller is not fed until the power supply of both indoor unit and outdoor unit is on and the start-up of both units is finished normally.</p> <ul style="list-style-type: none"> The power supply of the indoor unit is not on. The power supply of the outdoor unit is not on. The number of connected remote controller is over the limit (Maximum: 2 units) or the number of connected indoor unit that is over the limit (Maximum: 16 units). The address of the indoor unit is "00" and the address for the outdoor unit is the one other than "00". The transmission line of the indoor/outdoor unit is connected to TB15. MA remote controller is connected to the transmission line of the indoor/outdoor unit . The remote controller cable is shorted or down. The power supply cable or the transmission line is shorted or down. The fuse on the indoor unit controller board is blown. 	
"HO" keeps being displayed or it is displayed periodically. ("HO" is usually displayed for 3 minutes at the longest after the power supply of the outdoor unit is on.)	<ul style="list-style-type: none"> The power supply of the outdoor unit is not on. The power supply of the feeding expansion unit for the transmission line is not on. The setting of MA remote controller is not main remote controller, but sub-remote controller. MA remote controller is connected to the transmission line of the indoor/outdoor unit. 	
The remote controller does not operate though (●) is displayed.	<ul style="list-style-type: none"> The power supply of the indoor unit (Master) is not on. The transmission line of the indoor/outdoor unit is connected to TB15. The transmission line of the indoor/outdoor unit is shorted, down or badly contacted. The fuse on the indoor unit controller board is blown. 	

9-4. THE FOLLOWING SYMPTON DO NOT REPRESENT TROUBLE (EMERGENCY)

Symptom	Display of remote controller	CAUSE
Even the cooling (heating) operation selection button is pressed, the indoor unit cannot be operated.	"Cooling (Heating)" blinks	The indoor unit can not cool (heat) if other indoor units are heating (cooling).
The auto vane runs freely.	Normal display	Because of the control operation of auto vane, it may change over to horizontal blow automatically from the downward blow in cooling in cause the downward blow operation has been continued for one hour. At defrosting in heating, hot adjusting and thermostat OFF, it automatically changes over to horizontal blow.
Fan setting changes during heating.	Normal display	Ultra-low speed operation is commenced at thermostat OFF. Light air automatically change over to set value by time or piping temperature at thermostat ON.
Fan stops during heating operation.	"Defrost ☆"	The fan is to stop during defrosting.
Fan does not stop while operation has been stopped.	Light out	Fan is to run for one minute after stopping to exhaust residual heat (only in heating).
No setting of fan while start SW has been turned on.	STAND BY ☆	Ultra-low speed operation for 5 minutes after SW ON or until piping temperature becomes 35°C. There low speed operate for 2 minutes, and then set notch is commenced. (Hot adjust control)
Indoor unit remote controller shows "HO" indicator for about two minutes when turning ON power supply.	"HO" blinks	System is being driven. Operate remote controller again after "HO" disappears.
Drain pump does not stop while unit has been stopped.	Light out	After a stop of cooling operation, unit continues to operate drain pump for three minutes and then stops it.
Drain pump continues to operate while unit has been stopped.	—	Unit continues to operate drain pump if drainage is generated, even during a stop.







9-5. INTERNAL SWITCH FUNCTION TABLE

9-5-1. Outdoor unit internal switch function table (PUMY-P125VMA PUMY-P125VMA₁)

Switch	Step	Function	Operation in Each Switch Setting			Remarks																																
			ON	OFF	When to Set																																	
SW U1 1st digit SW U2 2nd digit	Rotary switch	 SWU2 (2nd digit)  SWU1 (1st digit) <p>* The address automatically becomes "100" if it is set as "01~50"</p>			Before turning the power on	<Factory Settings>  SWU2  SWU1 (2nd digit) (1st digit)																																
SW1 Digital Display Switching	1~8	ON <table border="1" style="display: inline-table; vertical-align: middle;"><tr><td> </td><td> </td><td> </td><td> </td><td> </td><td> </td><td> </td><td> </td></tr></table> OFF <table border="1" style="display: inline-table; vertical-align: middle;"><tr><td> </td><td> </td><td> </td><td> </td><td> </td><td> </td><td> </td><td> </td></tr></table> 1 2 3 4 5 6 7 8																			Can be set either during operation or not.	<Factory Settings> ON <table border="1" style="display: inline-table; vertical-align: middle;"><tr><td> </td><td> </td><td> </td><td> </td><td> </td><td> </td><td> </td><td> </td></tr></table> OFF <table border="1" style="display: inline-table; vertical-align: middle;"><tr><td> </td><td> </td><td> </td><td> </td><td> </td><td> </td><td> </td><td> </td></tr></table> 1 2 3 4 5 6 7 8																
SW2 function Switching	1	Selects operating system startup	Doesn't start up	Start up	Before turning the power on	<Factory Settings> ON <table border="1" style="display: inline-table; vertical-align: middle;"><tr><td> </td><td> </td><td> </td><td> </td><td> </td><td> </td><td> </td><td> </td></tr></table> OFF <table border="1" style="display: inline-table; vertical-align: middle;"><tr><td> </td><td> </td><td> </td><td> </td><td> </td><td> </td><td> </td><td> </td></tr></table> 1 2 3 4 5 6 7 8 9 10																																
	2	Connection Information Clear Switch	Clear	Do not clear																																		
	3	Abnormal data clear switch input	Clear abnormal data	Normal	OFF to ON any time after the power is turned on.																																	
	4	Refrigerant Volume Adjustment Operation	Run adjustment mode.	Normal	Can be set during compressor stopping.																																	
	5	During the FAN or COOL mode, and thermo - OFF or OFF in heating operation, set the opening of linear expansion valve on indoor unit.	Active	Inactive	While unit stopping.																																	
	6	During the FAN or COOL mode, and thermo - OFF in heating operation, set the opening of linear expansion valve on indoor unit.	Active	Inactive																																		
	7	Forced defrost	Forced defrost	Normal	OFF → ON, during compressor running in heating mode.																																	
	8	Defrost detection switching	Cumulative	Continuous	While unit stopping.																																	
9	Defrost disabled time selection	60 min.	30 min. (ordinary)																																			
10	Vacuum operation protection (error code 1505) is not detected.	Active	Inactive																																			
SW3 Trial operation	1	Enable/disable operation from outdoor unit	Enable	Disable	Any time after the power is turned on.	<Factory Settings> ON <table border="1" style="display: inline-table; vertical-align: middle;"><tr><td> </td><td> </td></tr></table> OFF <table border="1" style="display: inline-table; vertical-align: middle;"><tr><td> </td><td> </td></tr></table> 1 2																																
2	ON/OFF from the outdoor unit.	ON	OFF	※1																																		
SW4 Model Switching	1~4	<table border="1" style="display: inline-table; vertical-align: middle;"> <tr> <td>Service ref.</td> <td>SW4</td> </tr> <tr> <td>PUMY-P125VMA</td> <td>ON <table border="1" style="display: inline-table; vertical-align: middle;"><tr><td> </td><td> </td><td> </td><td> </td></tr></table></td> </tr> <tr> <td>PUMY-P125VMA₁</td> <td>OFF <table border="1" style="display: inline-table; vertical-align: middle;"><tr><td> </td><td> </td><td> </td><td> </td></tr></table></td> </tr> <tr> <td></td> <td>1 2 3 4</td> </tr> </table>	Service ref.	SW4	PUMY-P125VMA	ON <table border="1" style="display: inline-table; vertical-align: middle;"><tr><td> </td><td> </td><td> </td><td> </td></tr></table>					PUMY-P125VMA ₁	OFF <table border="1" style="display: inline-table; vertical-align: middle;"><tr><td> </td><td> </td><td> </td><td> </td></tr></table>						1 2 3 4			Before the power is turned on.	<Factory Settings> Set for each capacity.																
Service ref.	SW4																																					
PUMY-P125VMA	ON <table border="1" style="display: inline-table; vertical-align: middle;"><tr><td> </td><td> </td><td> </td><td> </td></tr></table>																																					
PUMY-P125VMA ₁	OFF <table border="1" style="display: inline-table; vertical-align: middle;"><tr><td> </td><td> </td><td> </td><td> </td></tr></table>																																					
	1 2 3 4																																					
SW5 function switching	1	Auto Change Over from Remote Controller	Enable	Disable	Before the power is turned on.	<Factory Settings> ON <table border="1" style="display: inline-table; vertical-align: middle;"><tr><td> </td><td> </td><td> </td><td> </td><td> </td><td> </td><td> </td><td> </td></tr></table> OFF <table border="1" style="display: inline-table; vertical-align: middle;"><tr><td> </td><td> </td><td> </td><td> </td><td> </td><td> </td><td> </td><td> </td></tr></table> 1 2 3 4 5 6 7 8																																
	2	Fixing the indoor units linear expansion valve opening	Fix	Normal	OFF → ON while compressor is not operating																																	
	3	Fixing the outdoor unit electronic expansion valve opening.	Fix	Normal																																		
	4	Enable fixing at the desired frequency	Enable	Disable	Any time after the power is turned on.																																	
	5	Maintain outdoor fan at fixed speed and ignore outdoor temperature sensor abnormality	Active	Inactive	While unit stopping.																																	
	6	Ignore refrigerant filling abnormality	Active	Inactive																																		
7	Switching the target discharge pressure (Pdm)	Pdm switching	Normal	Can be set when off or during operation																																		
8	Switching the target evaporation temperature (ETm)	ETm switching	Normal																																			
SW6 function switching	1	Switching the Input Current Limit Level	2 Amp down	Normal	Before turning the power on	<Factory Settings> ON <table border="1" style="display: inline-table; vertical-align: middle;"><tr><td> </td><td> </td><td> </td><td> </td><td> </td><td> </td><td> </td><td> </td></tr></table> OFF <table border="1" style="display: inline-table; vertical-align: middle;"><tr><td> </td><td> </td><td> </td><td> </td><td> </td><td> </td><td> </td><td> </td></tr></table> 1 2 3 4 5 6 7 8																																
2	Switching the High Pressure Limit Level	0.2 MPS up	Normal	While unit stopping																																		
3	Ignore current sensor error	Active	Inactive	While unit stopping																																		

※1 For the system utilizing R-Converter units (PAC-SF29LB), SW3 trial operation function is not available.

9-5-2. Outdoor unit internal switch function table (PUMY-P125YMA PUMY-P125YMA₁)

Switch	Step	Function	Operation in Each Switch Setting			Remarks								
			ON	OFF	When to Set									
SW U1 1st digit SW U2 2nd digit SW U3 3rd digit	Rotary switch	 SWU3 (3rd digit)  SWU2 (2nd digit)  SWU1 (1st digit)			Before turning the power on	<Factory Settings>  SWU3 (3rd digit)  SWU2 (2nd digit)  SWU1 (1st digit)								
SW1 Digital Display Switching	1~8	ON <input type="checkbox"/> <input type="checkbox"/> <input type="checkbox"/> <input type="checkbox"/> <input type="checkbox"/> <input type="checkbox"/> <input type="checkbox"/> <input type="checkbox"/> OFF <input checked="" type="checkbox"/> <input checked="" type="checkbox"/> <input checked="" type="checkbox"/> <input checked="" type="checkbox"/> <input checked="" type="checkbox"/> <input checked="" type="checkbox"/> <input checked="" type="checkbox"/> <input checked="" type="checkbox"/> 1 2 3 4 5 6 7 8			Can be set either during operation or not.	<Factory Settings> ON <input type="checkbox"/> <input type="checkbox"/> <input type="checkbox"/> <input type="checkbox"/> <input type="checkbox"/> <input type="checkbox"/> <input type="checkbox"/> <input type="checkbox"/> OFF <input checked="" type="checkbox"/> <input checked="" type="checkbox"/> <input checked="" type="checkbox"/> <input checked="" type="checkbox"/> <input checked="" type="checkbox"/> <input checked="" type="checkbox"/> <input checked="" type="checkbox"/> <input checked="" type="checkbox"/> 1 2 3 4 5 6 7 8								
SW2 function Switching	1	Selects operating system startup	Doesn't start up	Start up	Before turning the power on	<Factory Settings> ON <input type="checkbox"/> <input type="checkbox"/> <input type="checkbox"/> <input type="checkbox"/> <input type="checkbox"/> <input type="checkbox"/> <input type="checkbox"/> <input type="checkbox"/> OFF <input checked="" type="checkbox"/> <input checked="" type="checkbox"/> <input checked="" type="checkbox"/> <input checked="" type="checkbox"/> <input checked="" type="checkbox"/> <input checked="" type="checkbox"/> <input checked="" type="checkbox"/> <input checked="" type="checkbox"/> 1 2 3 4 5 6 7 8 9 10								
	2	Connection Information Clear Switch	Clear	Do not clear										
	3	Abnormal data clear switch input	Clear abnormal data	Normal	OFF to ON any time after the power is turned on.									
	4	Refrigerant Volume Adjustment Operation	Run adjustment mode.	Normal	Can be set during compressor stopping.									
	5	During the FAN or COOL mode, and thermo - OFF or OFF in heating operation, set the opening of linear expansion valve on indoor unit.	Active	Inactive	While unit stopping.									
	6	During the FAN or COOL mode, and thermo - OFF in heating operation, set the opening of linear expansion valve on indoor unit.	Active	Inactive										
	7	Forced defrost	Forced defrost	Normal	OFF → ON, during compressor running in heating mode.									
	8	Defrost detection switching	Cumulative	Continuous	While unit stopping.									
	9	Defrost disabled time selection	60 min.	30 min. (ordinary)										
	10	Vacuum operation protection (error code 1505) is not detected.	Active	Inactive										
SW3 Trial operation	1	Enable/disable operation from outdoor unit	Enable	Disable	Any time after the power is turned on.	<Factory Settings> ON <input type="checkbox"/> <input type="checkbox"/> OFF <input checked="" type="checkbox"/> <input checked="" type="checkbox"/> ※1 1 2								
	2	ON/OFF from the outdoor unit.	ON	OFF										
SW4 Model Switching	1~4	<table border="1" data-bbox="437 1469 783 1588"> <tr> <td>Service ref.</td> <td>SW4</td> </tr> <tr> <td>PUMY-P125YMA</td> <td>ON <input type="checkbox"/> <input type="checkbox"/> <input type="checkbox"/> <input type="checkbox"/></td> </tr> <tr> <td>PUMY-P125YMA₁</td> <td>OFF <input type="checkbox"/> <input checked="" type="checkbox"/> <input checked="" type="checkbox"/> <input checked="" type="checkbox"/></td> </tr> <tr> <td></td> <td>1 2 3 4</td> </tr> </table>	Service ref.	SW4	PUMY-P125YMA	ON <input type="checkbox"/> <input type="checkbox"/> <input type="checkbox"/> <input type="checkbox"/>	PUMY-P125YMA ₁	OFF <input type="checkbox"/> <input checked="" type="checkbox"/> <input checked="" type="checkbox"/> <input checked="" type="checkbox"/>		1 2 3 4			Before the power is turned on.	<Factory Settings> Set for each capacity.
Service ref.	SW4													
PUMY-P125YMA	ON <input type="checkbox"/> <input type="checkbox"/> <input type="checkbox"/> <input type="checkbox"/>													
PUMY-P125YMA ₁	OFF <input type="checkbox"/> <input checked="" type="checkbox"/> <input checked="" type="checkbox"/> <input checked="" type="checkbox"/>													
	1 2 3 4													
SW5 function switching	1	PUMY-P125YMA : Fix the operation frequency	Fix	Normal	OFF → ON while compressor is not operating	<Factory Settings> ON <input type="checkbox"/> <input type="checkbox"/> <input type="checkbox"/> <input type="checkbox"/> <input type="checkbox"/> <input type="checkbox"/> <input type="checkbox"/> <input type="checkbox"/> OFF <input checked="" type="checkbox"/> <input checked="" type="checkbox"/> <input checked="" type="checkbox"/> <input checked="" type="checkbox"/> <input checked="" type="checkbox"/> <input checked="" type="checkbox"/> <input checked="" type="checkbox"/> <input checked="" type="checkbox"/> 1 2 3 4 5 6 7 8								
		PUMY-P125YMA ₁ : Auto Change Over from Remote Controller	Enable	Disable	Before the power is turned on.									
	2	Fixing the indoor units linear expansion valve opening	Fix	Normal	OFF → ON while compressor is not operating									
	3	Fixing the outdoor unit electronic expansion valve opening.	Fix	Normal										
	4	Enable fixing at the desired frequency	Enable	Disable	While unit stopping.									
	5	Maintain outdoor fan at fixed speed and ignore outdoor temperature sensor abnormality	Active	Inactive										
	6	Ignore refrigerant filling abnormality	Active	Inactive										
	7	Switching the target discharge pressure (Pdm)	Pdm switching	Normal			Can be set when off or during operation							
8	Switching the target evaporation temperature (ETm)	ETm switching	Normal											

※1 For the system utilizing R-Converter units (PAC-SF29LB), SW3 trial operation function is not available.

9-6. OUTDOOR UNIT INPUT/OUTPUT CONNECTOR

● State (CN51)

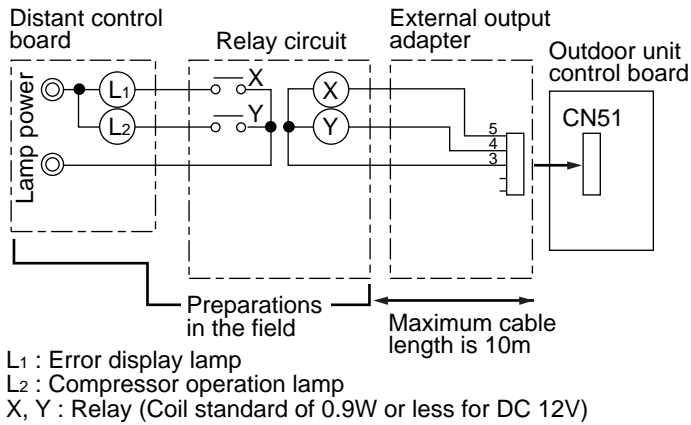

● Comp ON/OFF (CN3S)

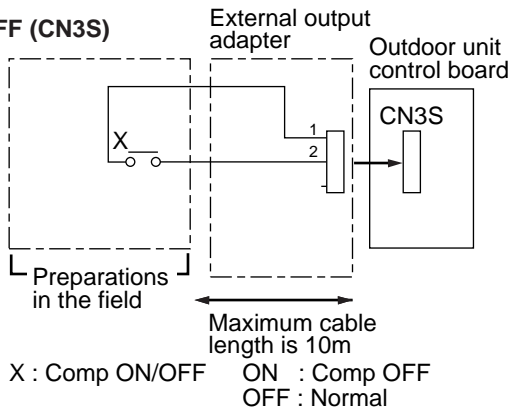

● Auto change over (CN3D)

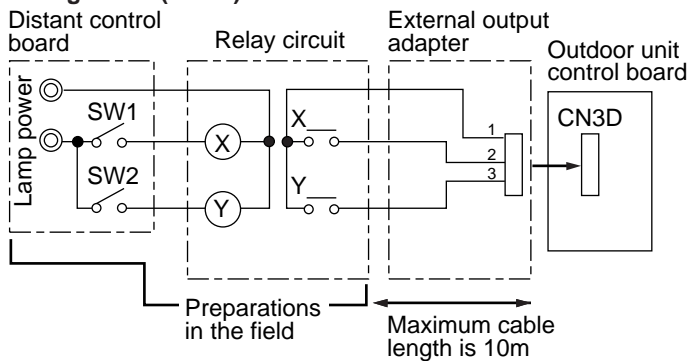

		ON	OFF
SW1	PUMY-P125YMA	Cooling	Heating
	PUMY-P125VMA	Heating	Cooling
	PUMY-P125VMA ₁ PUMY-P125YMA ₁		
SW2	PUMY-P125VMA	Validity of SW1	Invalidity of SW1
	PUMY-P125VMA ₁		
	PUMY-P125YMA PUMY-P125YMA ₁		

* For the system utilizing R-Converter units (PAC-SF29LB), the following systems are not available.
Group operation system, centralized controller, group remote controller, etc.
(See the installation manual of R-Converter units.)

* For the system utilizing R-Converter units (PAC-SF29LB), the following functions are not available.
Test run (SW3), auto change over, auto change over (external signal).
(See the installation manual of R-Converter units.)

9-7. HOW TO CHECK THE PARTS

PUMY-P125VMA PUMY-P125VMA₁ PUMY-P125YMA PUMY-P125YMA₁

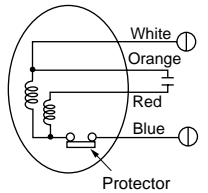
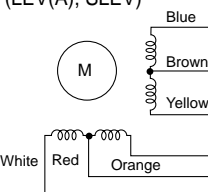
Parts name	Check points														
<ul style="list-style-type: none"> •Thermistor (TH1) <Discharge temperature detection> •Thermistor (TH2) <Low pressure saturated temperature detection> •Thermistor (TH5) <Pipe temperature detection / judging defrost> •Thermistor (TH6) <Outdoor temperature detection> •Thermistor (THHS A/B) <Radiator panel> PUMY-P125VMA ,VMA₁ •Thermistor (THHS) <IPM radiator panel temperature thermistor detection> PUMY-P125YMA,YMA₁ 	<p>Disconnect the connector then measure the resistance using a tester. (Surrounding temperature 10°C ~30°C)</p> <table border="1"> <thead> <tr> <th></th> <th>Normal</th> <th>Abnormal</th> </tr> </thead> <tbody> <tr> <td>TH1</td> <td>160kΩ~410kΩ</td> <td rowspan="4">Open or short</td> </tr> <tr> <td>TH2</td> <td rowspan="3">4.3kΩ~9.6kΩ</td> </tr> <tr> <td>TH5</td> </tr> <tr> <td>TH6</td> </tr> <tr> <td>THHS A/B THHS</td> <td>39kΩ~105kΩ</td> <td></td> </tr> </tbody> </table>		Normal	Abnormal	TH1	160kΩ~410kΩ	Open or short	TH2	4.3kΩ~9.6kΩ	TH5	TH6	THHS A/B THHS	39kΩ~105kΩ		
	Normal	Abnormal													
TH1	160kΩ~410kΩ	Open or short													
TH2	4.3kΩ~9.6kΩ														
TH5															
TH6															
THHS A/B THHS	39kΩ~105kΩ														
<p>FAN MOTOR (MF1,2)</p> 	<p>Measure the resistance between the terminals using a tester. (Part wiring temperature 20°C)</p> <table border="1"> <thead> <tr> <th>Motor lead wire</th> <th>Normal</th> <th>Abnormal</th> </tr> </thead> <tbody> <tr> <td>White — Blue</td> <td>107.5Ω ±10%</td> <td rowspan="2">Open or short</td> </tr> <tr> <td>Blue — Red</td> <td>128.0Ω ±10%</td> </tr> </tbody> </table> <p>Opening and closing temperature of protector. Open: 135±5°C (Fan motor OFF) Close: 86±15°C (Fan motor ON)</p>	Motor lead wire	Normal	Abnormal	White — Blue	107.5Ω ±10%	Open or short	Blue — Red	128.0Ω ±10%						
Motor lead wire	Normal	Abnormal													
White — Blue	107.5Ω ±10%	Open or short													
Blue — Red	128.0Ω ±10%														
<p>Expansion valve (LEV(A), SLEV)</p> 	<p>Disconnect the connector then measure the resistance using a tester. (Part wiring temperature 20°C)</p> <table border="1"> <thead> <tr> <th colspan="4">Normal</th> <th>Abnormal</th> </tr> </thead> <tbody> <tr> <td>White - Red</td> <td>Yellow - Brown</td> <td>Orange - Red</td> <td>Blue - Brown</td> <td rowspan="2">Open or short</td> </tr> <tr> <td colspan="4">150Ω ±10%</td> </tr> </tbody> </table>	Normal				Abnormal	White - Red	Yellow - Brown	Orange - Red	Blue - Brown	Open or short	150Ω ±10%			
Normal				Abnormal											
White - Red	Yellow - Brown	Orange - Red	Blue - Brown	Open or short											
150Ω ±10%															
<p>4-WAY COIL (21S4)</p>	<p>Measure the resistance between the terminals using a tester. (Part wiring temperature 20°C)</p> <table border="1"> <thead> <tr> <th>Normal</th> <th>Abnormal</th> </tr> </thead> <tbody> <tr> <td>1430Ω</td> <td>Open or short</td> </tr> </tbody> </table>	Normal	Abnormal	1430Ω	Open or short										
Normal	Abnormal														
1430Ω	Open or short														
<p>SOLENOID COIL (SV1)</p>	<p>Measure the resistance between the terminals using a tester. (Part wiring temperature 20°C)</p> <table border="1"> <thead> <tr> <th>Normal</th> <th>Abnormal</th> </tr> </thead> <tbody> <tr> <td>1970Ω</td> <td>Open or short</td> </tr> </tbody> </table>	Normal	Abnormal	1970Ω	Open or short										
Normal	Abnormal														
1970Ω	Open or short														

<Thermistor feature chart>

Low temperature thermistors

- Thermistor (TH2) <Low pressure saturated temperature detection>
- Thermistor (TH5) <Pipe temperature detection / judging defrost>
- Thermistor (TH6) <Outdoor temperature detection>

Thermistor R₀ = 15kΩ ± 3%

B constant = 3480K ± 2%

$$R_t = 15 \exp\left\{3480 \left(\frac{1}{273+t} - \frac{1}{273} \right)\right\}$$

0°C 15kΩ 30°C 4.3kΩ

10°C 9.6kΩ 40°C 3.0kΩ

20°C 6.3kΩ

25°C 5.4kΩ

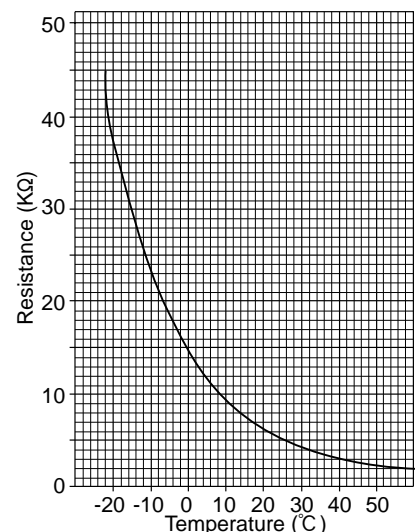

From the preceding page.

PUMY-P125VMA PUMY-P125VMA₁

Medium temperature thermistor

•Thermistor (THHS A/B) <Radiator panel>

Thermistor R50 = 17kΩ ± 2%

B constant = 4150K ± 3%

$$R_t = 17 \exp\left\{4150 \left(\frac{1}{273+t} - \frac{1}{323} \right)\right\}$$

0°C	180kΩ
25°C	50kΩ
50°C	17kΩ
70°C	8kΩ
90°C	4kΩ

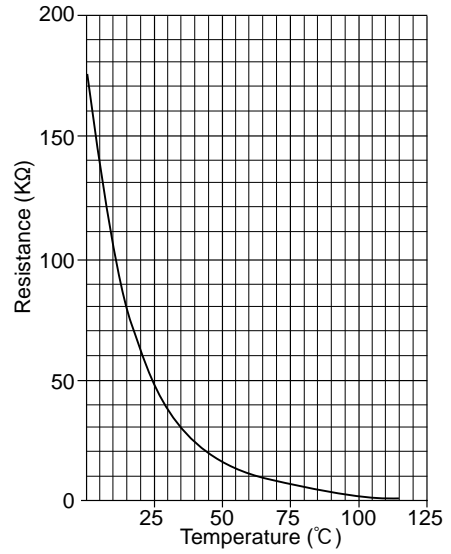

PUMY-P125YMA, PUMY-P125YMA₁

Medium temperature thermistor

•Thermistor (THHS) <IPM radiator panel temperature thermistor detection>

Thermistor R50 = 17kΩ ± 2%

B constant = 4170K ± 3%

$$R_t = 17 \exp\left\{4170 \left(\frac{1}{273+t} - \frac{1}{323} \right)\right\}$$

0°C	180kΩ
25°C	50kΩ
50°C	17kΩ
70°C	8kΩ
90°C	4kΩ

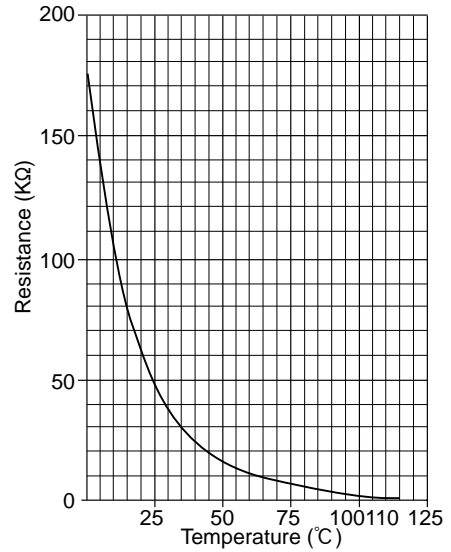

High temperature thermistor

•Thermistor (TH1) <Discharge temperature detection>

Thermistor R120 = 7.465kΩ ± 2%

B constant = 4057K ± 2%

$$R_t = 7.465 \exp\left\{4057 \left(\frac{1}{273+t} - \frac{1}{393} \right)\right\}$$

20°C	250kΩ	70°C	34kΩ
30°C	160kΩ	80°C	24kΩ
40°C	104kΩ	90°C	17.5kΩ
50°C	70kΩ	100°C	13.0kΩ
60°C	48kΩ	110°C	9.8kΩ

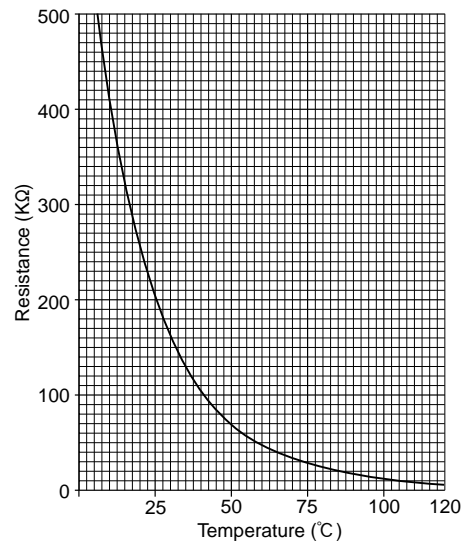

<HIGH PRESSURE SENSOR>

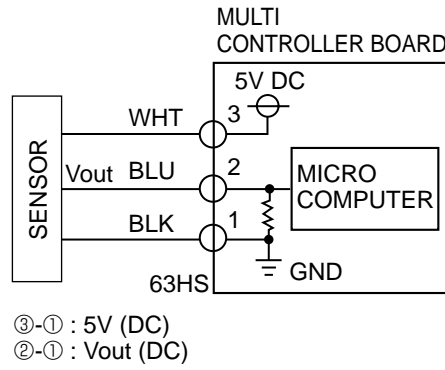
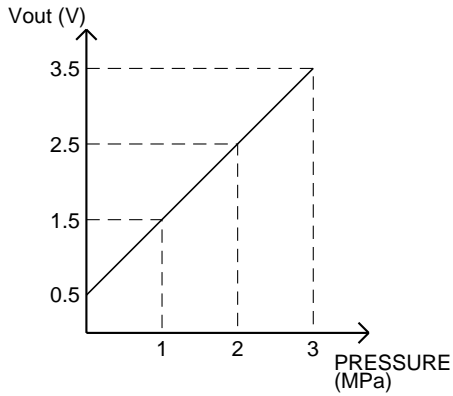

Expansion valve (LEV(A), SLEV: Outdoor unit)

①Notes on expansion valve action

- LEV(A), SLEV to stepping motor ON/OFF after outdoor controller board has received pulse signal.
- The valve position can be changed according to the pulse signal number ratio.

<connection between the LEV(A), SLEV and the outdoor controller board>

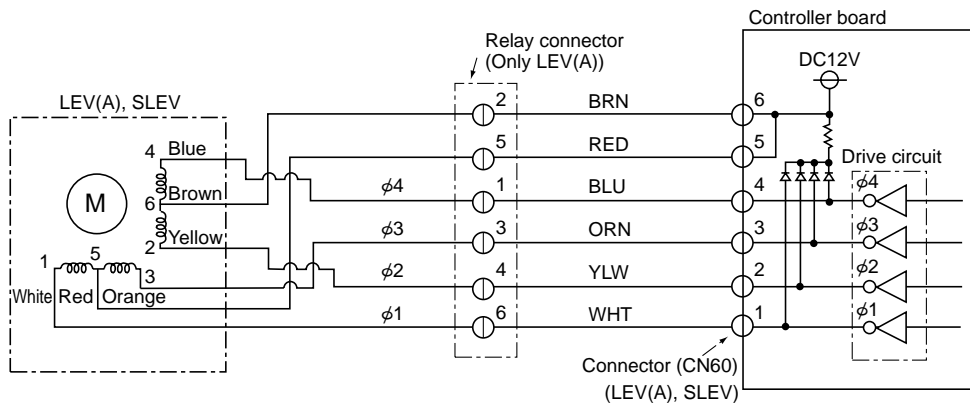

Note: Because the numbers of the relay connector and the connector on the controller board side are different, wiring work must rely on the colors of the wires.

To be continued on the next page.

From the preceding page.

③ Troubleshooting

<Output pulse signal and valve action>

Output(phase)	Output			
	1	2	3	4
φ1	ON	OFF	OFF	ON
φ2	ON	ON	OFF	OFF
φ3	OFF	ON	ON	OFF
φ4	OFF	OFF	ON	ON

Valve closing: 1→2→3→4→1
Valve opening: 4→3→2→1→4

The address of the pulse output is shifted using the procedures mentioned earlier.

- ※1. All output phase will turn OFF when the LEV(A), SLEV stops operating.
- 2. When the output phase is terminated or when the phase shift is not according to frequency, the motor rotation will become irregular, causing the motor to vibrate or lockup.

※ When the power supply is on, the closing signal of 2,200 pulse will be transmitted to decide the position of the valve. The valve position can be determined when point (A) is reached.

The LEV(LEV(A), SLEV) will not vibrate or make noise when the valve is operating smoothly. However, when the number of pulses change from (E) to (A), or if the valve lockup, there may be more noise than under normal circumstances.

- The noise can be heard by resting your ear on the handle of a screwdriver that is pressed against the top of the LEV(LEV(A), SLEV) valve.

② LEV(A), SLEV action

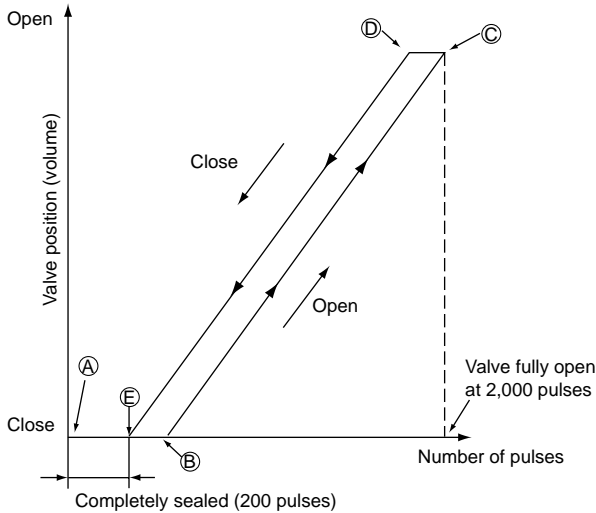

Problem	Check point	Corrective measure
Malfunction in microprocessor operating circuit	Remove the connector from the controller board and connect diagnostic LEDs. When power is turned on, pulse signals will output for 10 seconds. There must be some defects in the operation circuit if the LED does not light while the signals are output or keeps lighting even after the signals stop.	Replace the indoor unit controller board or Replace the outdoor multi controller board.
Locked expansion valve	If the linear expansion valve (indoor unit) or electronic expansion valve (outdoor unit) becomes locked and the motor is still operating, the motor will emit a clicking noise and will not function. This clicking noise indicates an abnormality.	Replace the linear expansion valve or electronic expansion valve
Short circuit or broken circuit in expansion valve motor coil	Use an all-purpose electrical meter to measure the resistance between the different coils (white-red, yellow-brown, orange-red, blue-brown). Normal resistance is within a range of 150Ω±10%.	Replace the linear expansion valve or electronic expansion valve
Valve does not close completely	In order to check the linear expansion valve, operate one indoor unit in the fan mode and another in the cooling mode. Then, use the outdoor multi controller board to operate the monitor and check the pipe temperature of the indoor unit (liquid pipe temperature). The linear expansion valve should be fully closed when the fan is operating. The temperature measured by the temperature sensor will drop if there is any leakage. If the measured temperature is significantly lower than that on the remote controller, this indicates that the valve is not closed. It is not necessary to replace the linear expansion valve if the leak of refrigerant is small and does not cause a malfunction. 	Replace the linear expansion valve if there is a major leak of refrigerant.
Incorrect connection or connection failure	① Check improperly connected connector terminals and the wire colors. ② Remove the connector on the controller board side and check electrical conductance	Continuity check of wrong part.

9-8. TEST POINT DIAGRAM

9-8-1. Outdoor multi controller board

PUMY-P125YMA
PUMY-P125YMA₁

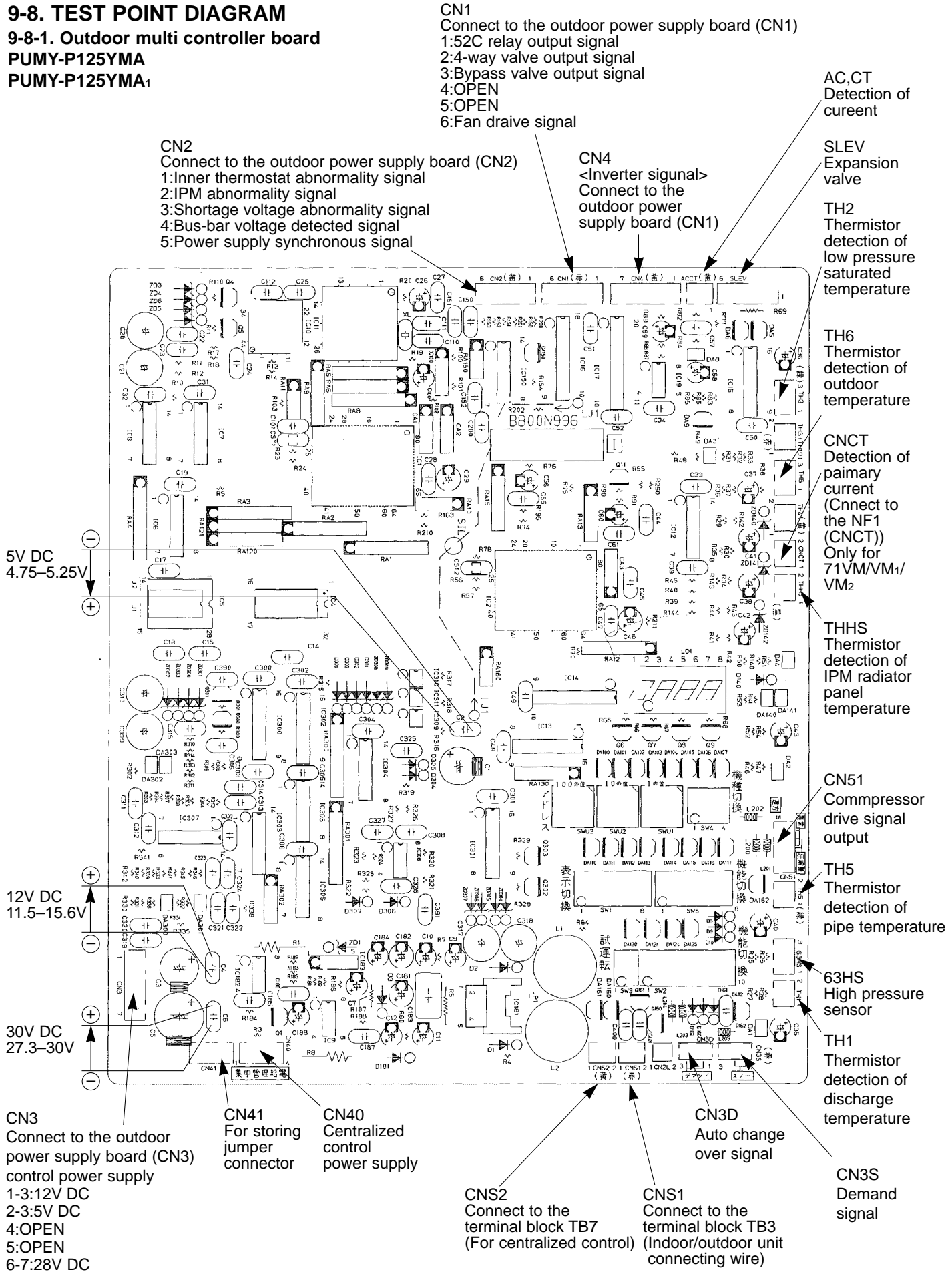

9-8-2. Outdoor power supply board
PUMY-P125YMA
PUMY-P125YMA₁

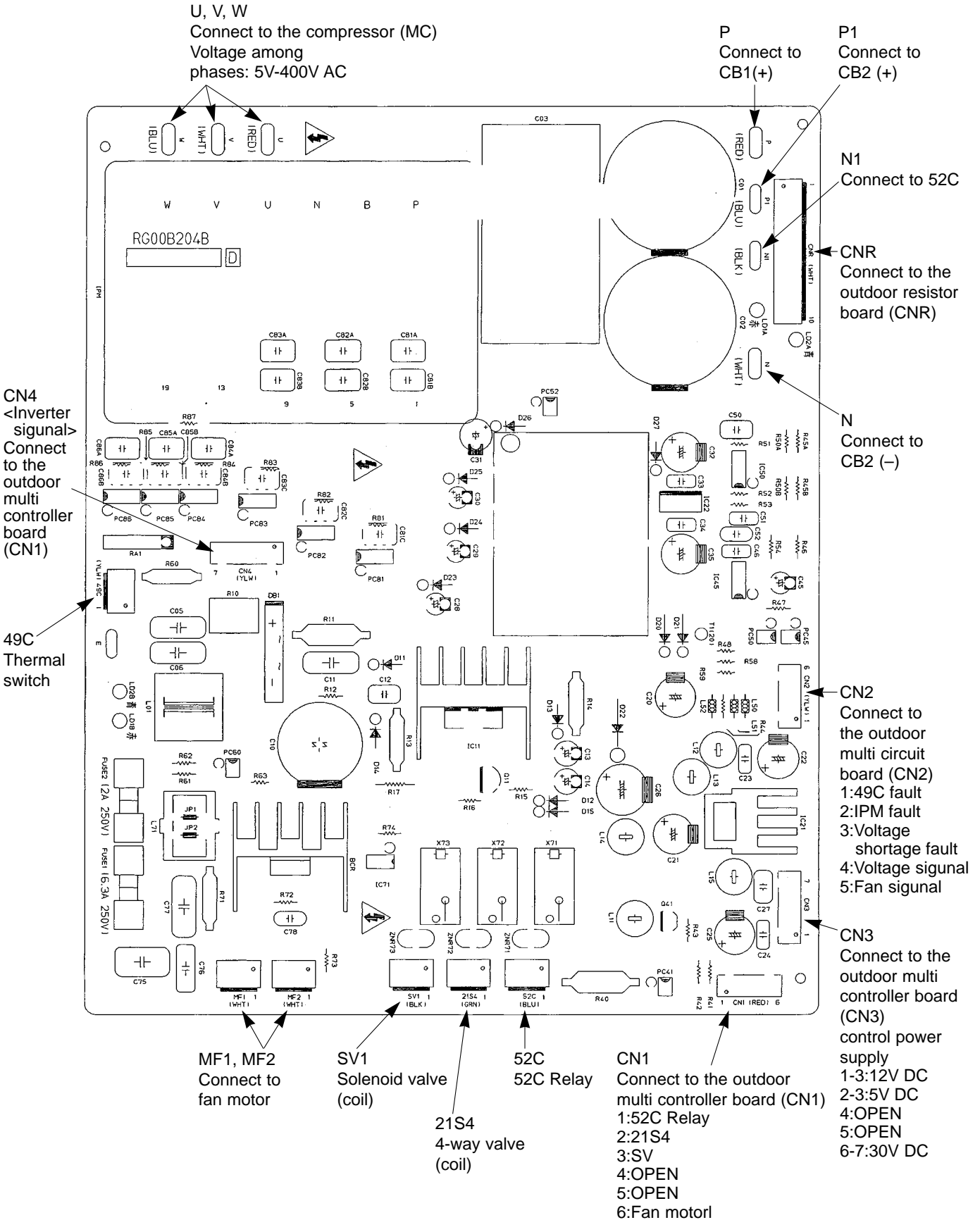

9-8-3. Outdoor resistor board
PUMY-P125YMA
PUMY-P125YMA₁

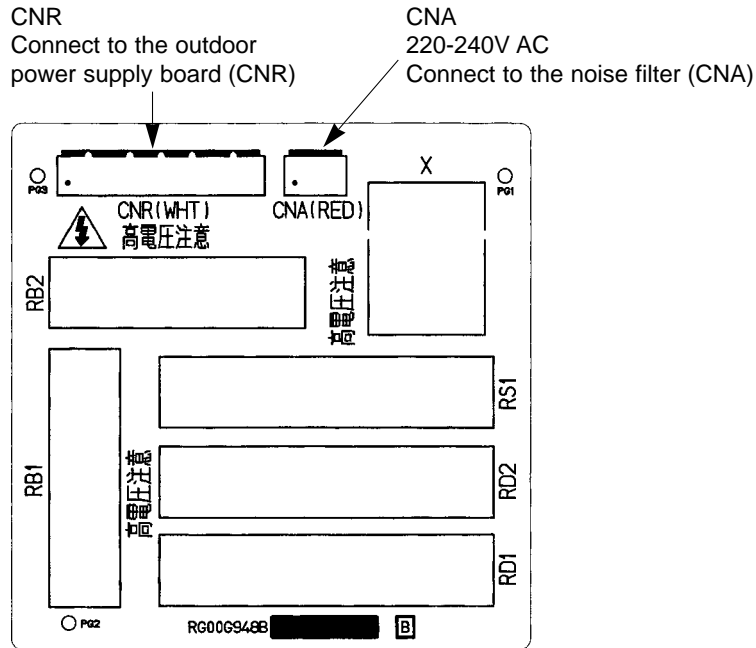

9-8-4. Outdoor multi circuit board
PUMY-P125VMA
PUMY-P125VMA₁

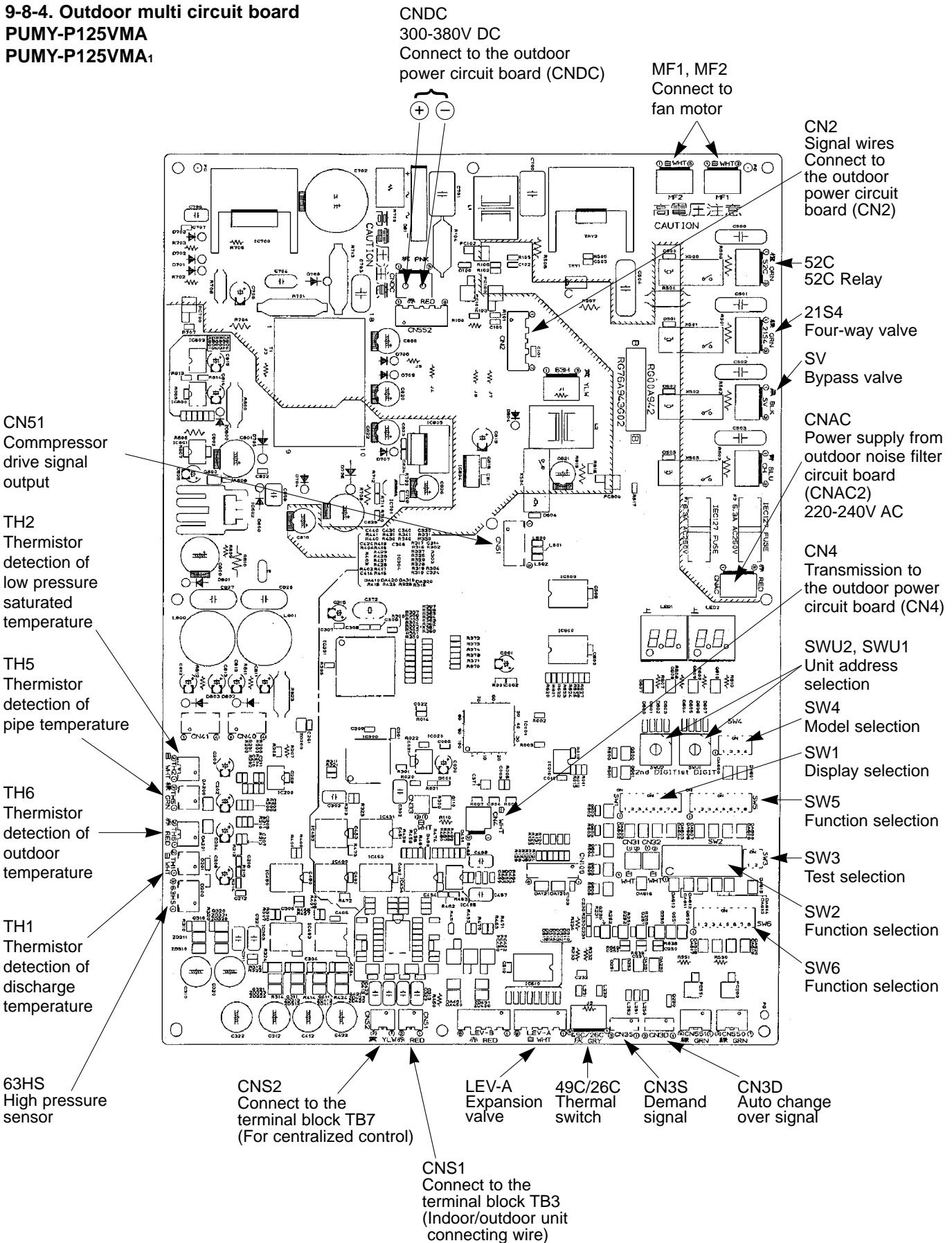

9-8-5. Outdoor power circuit board
PUMY-P125VMA
PUMY-P125VMA₁

Brief Check of POWER MODULE
 * Usually, they are in a state of being short-circuited if they are broken. Measure the resistance in the following points (connectors, etc.).
 If they are short-circuited, it means that they are broken.

1. Check of POWER MODULE

①. Check of DIODE circuit
 [L]-P1, [N]-P1, [L]-N1, [N]-N1

②. Check of IGBT circuit
 [P2]-U, [P2]-V, [P2]-W, [N2]-U, [N2]-V, [N2]-W

Note: The marks, [L], [N], [N1], [N2], [P1], [P2], [U], [V] and [W] shown in the diagram above are not actually printed on the board.

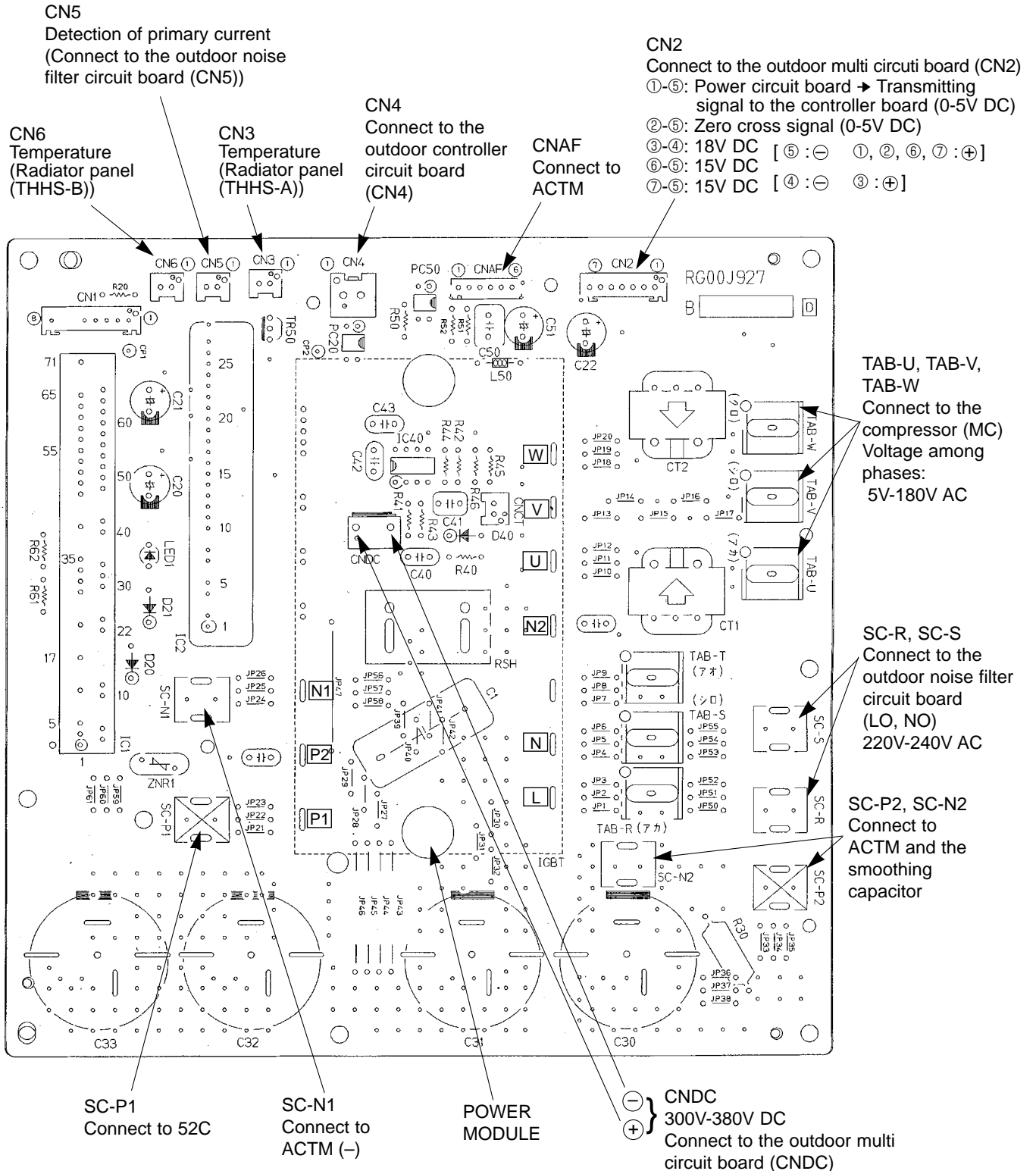

9-8-6. Outdoor noise filter circuit board
PUMY-P125VMA
PUMY-P125VMA₁

LO, NO
 Voltage of 220-240V AC is output
 (Connect to the outdoor power
 circuit board (SC-R, SC-S))

CNAC1, CNAC2
 220-240V AC
 (Connect to the
 outdoor multi circuit
 board (CNAC))

EI
 Connect to
 the earth

CN5
 Primary current
 (Connect to the
 outdoor power
 circuit board
 (CN5))

LI, NI
 Voltage of 220-240V AC is input
 (Connect to the terminal block(TB1))

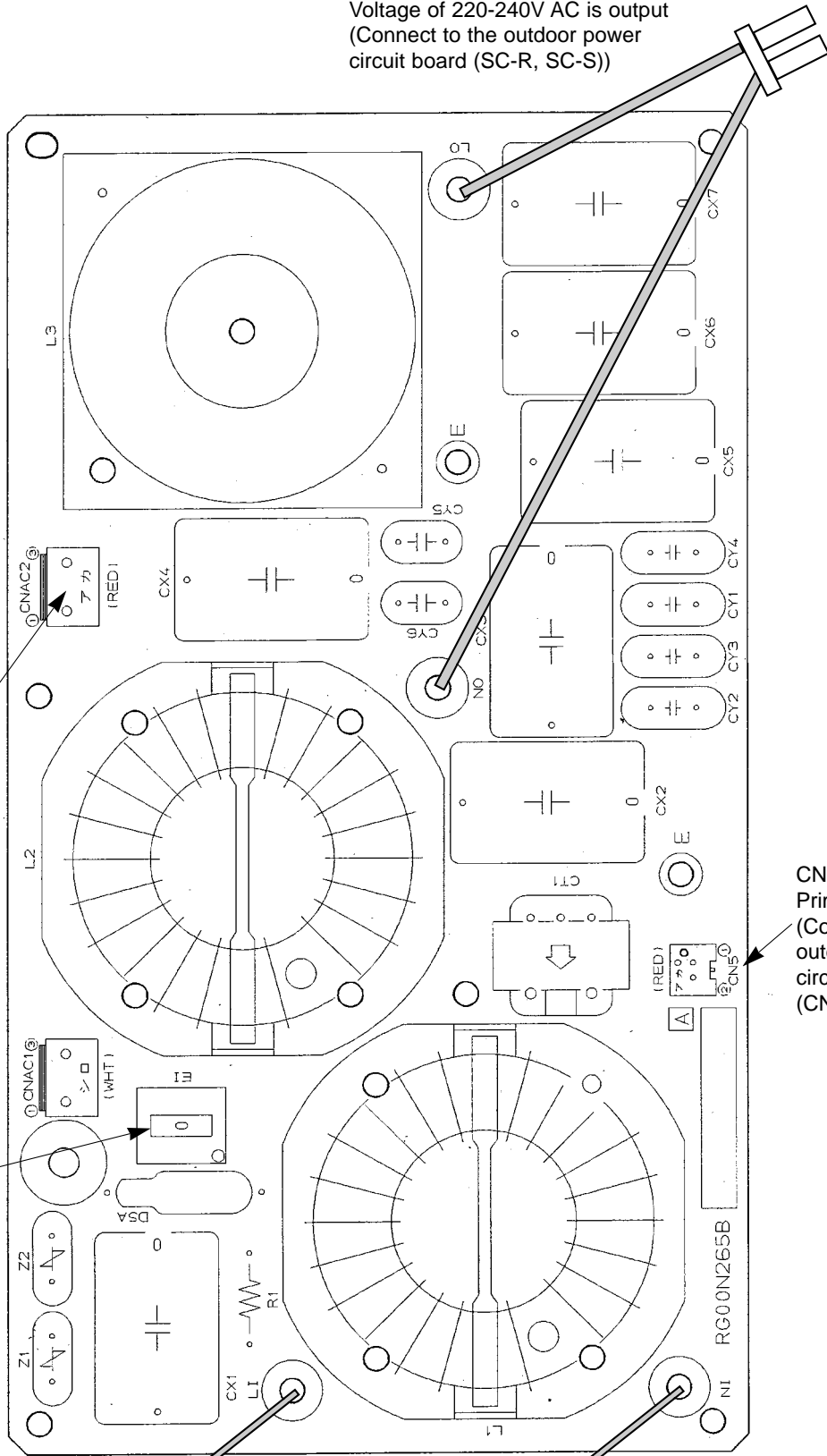

9-9. OUTDOOR UNIT FUNCTIONS

SW:setting
0...OFF
1...ON

No.	SW1 setting	Display mode	Display on the LD1 (display data)								Notes
			1	2	3	4	5	6	7	8	
0	00000000	Relay output display	Compressor operation	52C	21S4	SV					Lighting always ON: light on OFF: light off
		Check display	0000~9999 (Alternating display of addresses and error code)								•When abnormality occurs, check display.
1	10000000	Indoor unit check status	No.2 unit check	No.3 unit check	No.4 unit check	No.5 unit check	No.6 unit check	No.7 unit check	No.8 unit check		Check: light on Normal: light off
2	01000000	Protection input	Discharge temperature abnormality	Inner thermostat abnormality	IPM abnormality	Radiator panel abnormality	Vacuum operation abnormality	Power synchronization abnormality	63HS abnormality		Display input microprocessor protection (abnormality)
3	11000000	Protection input	TH2 abnormality	TH6 abnormality	TH5 abnormality	Indoor unit capacity	THHS abnormality	Restrict power IPM abnormality			
4	00100000	Protection input	Address double setting abnormality	Indoor unit capacity	Over capacity	Indoor unit address error	Outdoor unit address error	Refrigerant over charge abnormality	Insufficient voltage abnormality		
5	10100000	Abnormality delay display 1	Discharge temperature abnormality delay	Internal thermostat abnormality delay	IPM abnormality delay	Radiator panel overheating delay	THHS abnormality delay	Power synchronization signal abnormality delay	63HS sensor abnormality delay		Display all abnormalities remaining in abnormality delay
6	01100000	Abnormality delay display 2	TH2 abnormality delay	TH6 abnormality delay	TH5 abnormality delay			Restrict power IPM abnormality delay	Single-phase current delay(CT)		
7	11100000	Abnormality delay display 3						Refrigerant over charge delay	Insufficient voltage abnormality delay		
8	00010000	Abnormality delay history 1	Discharge temperature abnormality delay	Internal thermostat abnormality delay	IPM abnormality delay	Radiator panel overheating delay		Power synchronization signal abnormality delay	63HS abnormality delay		Display all abnormalities remaining in abnormality delay history
9	10010000	Abnormality delay history 2	TH2 abnormality delay	TH6 abnormality delay	TH5 abnormality delay			Restrict power IPM abnormality delay	Single-phase current delay(CT)		
10	01010000	Abnormality delay history 3						Refrigerant over charge abnormality delay	Insufficient voltage abnormality delay		
11	11010000	Abnormality code history 1 (the latest)									
12	00110000	Abnormality code history 2									
13	10110000	Abnormality code history 3									
14	01110000	Abnormality code history 4									
15	11110000	Abnormality code history 5									
16	00001000	Abnormality code history 6									
17	10001000	Abnormality code history 7									
18	01001000	Abnormality code history 8									
19	11001000	Abnormality code history 9									
20	00101000	Abnormality code history 10 (the oldest)									
21	10101000	Cumulative time	0~9999(unit:::1-hour)								Display of cumulative compressor operating time
22	01101000	Cumulative time	0~9999(unit:::10-hour)								
23	11101000	Outdoor unit operation display	Excitation Current	Restart after 3 minutes	Compressor operation	Abnormality(detection)					
24	00011000	Indoor unit operation mode	No.1 unit mode	No.2 unit mode	No.3 unit mode	No.4 unit mode	No.5 unit mode	No.6 unit mode	No.7 unit mode	No.8 unit mode	Cooling: light on Heating: light flashing Stop fan: light off
25	10011000	Indoor unit operation display	No.1 unit operation	No.2 unit operation	No.3 unit operation	No.4 unit operation	No.5 unit operation	No.6 unit operation	No.7 unit operation	No.8 unit operation	Thermo ON: light on Thermo OFF: light off
26	01011000	Capacity code (No. 1 indoor unit)	0~255								•Display of indoor unit capacity code
27	11011000	Capacity code (No. 2 indoor unit)									
28	00111000	Capacity code (No. 3 indoor unit)									
29	10111000	Capacity code (No. 4 indoor unit)									
30	01111000	Capacity code (No. 5 indoor unit)									•The No. 1 unit will start from the address with the lowest number

Abnormality delay	Delay code	Abnormality delay
Discharge temperature abnormality	1402	High-pressure abnormality
Discharge temperature sensor (TH1) abnormality		Pressure sensor (63HS) abnormality
Intake outlet temperature sensor (TH5) abnormality	1600	Over charge refrigerant abnormality
Compressor internal thermostat abnormality	1601	Insufficient refrigerant abnormality
Saturation temperature of suction pressure sensor (TH2) abnormality	4165	Power synchronization signal abnormality
Radiator panel thermistor (THHS) abnormality	4320	Frequency converter insufficient wiring voltage abnormality
Outside air temperature sensor (TH6) abnormality	4330	Radiator panel temperature abnormality
	4350	IPM abnormality

Alternating display of addresses
0000-9999 and abnormality code
(including abnormality delay code)

•Display abnormalities up to present (including abnormality terminals)
•History record in 1 is the latest; records become older in sequence; history record in 10 is the oldest.

No.	SW1 setting	Display mode	Display on the LD1 (display data)								Notes	
			1	2	3	4	5	6	7	8		
31	11111000	IC1 operation mode	OFF	Fan	Cooling thermo ON	Cooling thermo OFF	Heating thermo ON	Heating thermo OFF				•Display of indoor unit operating mode
32	00000100	IC2 operation mode										
33	10000100	IC3 operation mode										
34	01000100	IC4 operation mode										
35	11000100	IC5 operation mode										
36	00100100	OC operational mode	ON/OFF	Heating/Cooling	Abnormal/Normal	DEFROST/NO	Refrigerant pull back/no	Excitation current/no	3-min.delay/no			Light on/light off
37	10100100	External connection status	Demand junction									Input: light off No input: light on
38	01100100	Communication demand capacity	0~255									Display of communication demand capacity
40	00001000	Compressor operating current	0.0~50.0 (A)									PUMY-P125VMA
41	10010100	Input current of outdoor unit	0.0~50.0 (A)									PUMY-P125VMA
45	10110100	DC bus voltage	0~500 (V)									PUMY-P125VMA
64	00000010	Operational frequency	0~FF(16 progressive)									Display of actual operating frequency
65	10000010	Target frequency	0~255									Display of target frequency
66	01000010	Outdoor fan control step number	0~20									Display of number of outdoor fan control steps (target)
67	11000010	EER fan control step number (cooling)										
68	00100010	OC SLEV opening pulse	0~2000									Display of opening pulse of outdoor SLEV and indoor LEV
69	10100010	IC1 LEV Opening pulse										
70	01100010	IC2 LEV Opening pulse										
71	11100010	IC3 LEV Opening pulse										
72	00010010	IC4 LEV Opening pulse										
73	10010010	IC5 LEV Opening pulse										
74	01010010	High-pressure sensor (Pc)										
75	11010010	TH1(Td)										
76	00110010	TH2(ET)										
77	10110010	TH6										
78	01110010	TH5										
80	00001010	THHS										
81	10001010	IC1 TH23										
82	01001010	IC2 TH23										
83	11001010	IC3 TH23										
84	00101010	IC4 TH23										
85	10101010	IC5 TH23										
86	01101010	IC1 TH22										
87	11101010	IC2 TH22										

-99.9 ~ 999.9 (short circuit/open: -99.9 or 999.9)

No.	SW1 setting	Display mode	Display on the LD1 (display data)								Notes
			1	2	3	4	5	6	7	8	
88	00011010	IC3 TH22	-99.9 ~ 999.9 (short circuit/open: -99.9 or 999.9)								Display of outdoor subcool (SC) data and detection data from high-pressure sensor and each thermistor
89	10011010	IC4 TH22									
90	01011010	IC5 TH22									
91	11011010	IC1 TH21									
92	00111010	IC2 TH21									
93	10111010	IC3 TH21	-99.9 ~ 999.9 (short circuit/open: -99.9 or 999.9) during heating: subcool (SC)/during cooling: superheat (SH)								Display of indoor SC/SH data
94	01111010	IC4 TH21									
95	11111010	IC5 TH21									
96	00000110	Outdoor SC (cooling)									
97	10000110	Target subcool step									
98	01000110	IC1 SC/SH	-99.9 ~ 999.9								Display of target subcool step data
99	11000110	IC2 SC/SH									
100	00100110	IC3 SC/SH									
101	10100110	IC4 SC/SH									
102	01100110	IC5 SC/SH									
103	11100110	Discharge superheat	-99.9 ~ 999.9								Display of discharge superheat data
105	10010110	Target Pd display (heating)									
106	01010110	Target ET display (cooling)									
107	11010110	Target outdoor SC (cooling)									
108	00110110	Target indoor SC/SH (IC1)									
109	10110110	Target indoor SC/SH (IC2)	Pdm(0.0~22.0) ETm(-1.0~8.0) SCm(0.0~10.0) SCm/SHm(0.0~14.0)								Display of all control target data
110	01110110	Target indoor SC/SH (IC3)									
111	11110110	Target indoor SC/SH (IC4)									
112	00001110	Target indoor SC/SH (IC5)									
128	00000001	Actual frequency of abnormality delay									
129	10000001	Fan step number at time of abnormality delay	0-FF(16 progressive) 0~20								Display of actual frequency at time of abnormality delay Display of fan step number at time of abnormality delay
130	01000001	OC SLEV opening pulse abnormality delay									
131	11000001	IC1 LEV opening pulse abnormality delay									
132	00100001	IC2 LEV opening pulse abnormality delay									
133	10100001	IC3 LEV opening pulse abnormality delay									
134	01100001	IC4 LEV opening pulse abnormality delay	0~2000								Display of opening pulse outdoor SLEV and indoor LEV at time of abnormality delay
135	11100001	IC5 LEV opening pulse abnormality delay									

No.	SW1 setting 12345678	Display mode	Display on the LD1 (display data)								Notes
			1	2	3	4	5	6	7	8	
136	00010001	High-pressure sensor data at time of abnormality delay									Display of data from high-pressure sensor, all thermistors, and SC/SH at time of abnormality delay
137	10010001	TH1 sensor data at time of abnormality delay									
138	01010001	TH2 sensor data at time of abnormality delay									
139	11010001	TH5 sensor data at time of abnormality delay									
140	00110001	THHS sensor data at time of abnormality delay									
141	10110001	OC SC (cooling) at time of abnormality delay									
142	01110001	IC1 SC/SH at time of abnormality delay									-99.9 ~ 999.9 (short circuit/open: -99.9 or 999.9)
143	11110001	IC2 SC/SH at time of abnormality delay									
144	00001001	IC3 SC/SH at time of abnormality delay									
145	10001001	IC4 SC/SH at time of abnormality delay									
146	01001001	IC5 SC/SH at time of abnormality delay									
192	00000011	Actual frequency at time of abnormality									0-FF (16progressive)
193	10000011	Fan step number at time of abnormality									0-20
194	01000011	OC SLEV opening pulse at time of abnormality									
195	11000011	IC1 LEV opening pulse at time of abnormality									
196	00100011	IC2 LEV opening pulse at time of abnormality									0-2000
197	10100011	IC3 LEV opening pulse at time of abnormality									
198	01100011	IC4 LEV opening pulse at time of abnormality									
199	11100011	IC5 LEV opening pulse at time of abnormality									
200	00010011	High-pressure sensor data at abnormality									
201	10010011	TH 1 sensor data at time of abnormality									
202	01010011	TH 2 sensor data at time of abnormality									
203	11010011	TH 5 sensor data at time of abnormality									
204	00110011	THHS sensor data at time of abnormality									
205	10110011	OC SC (Cooling) at time of abnormality									-99.9 ~ 999.9 (short circuit/open: -99.9 or 999.9)
206	01110011	IC1 SC/SH at time of abnormality									
207	11110011	IC2 SC/SH at time of abnormality									
208	00001011	IC3 SC/SH at time of abnormality									
209	10001011	IC4 SC/SH at time of abnormality									
210	01001011	IC5 SC/SH at time of abnormality									

No.	SW1 setting 12345678	Display mode	Display on the LD1 (display data)								Notes	
			1	2	3	4	5	6	7	8		
211	11001011	IC6 Capacity code	0~255								Display of indoor unit capacity mode	
212	00101011	IC7 Capacity code	0~255								Display of indoor unit capacity mode	
213	10101011	IC8 Capacity code	0~255								Display of indoor unit capacity mode	
214	01101011	IC6 operation mode	OFF	Fan	Cooling thermo ON	Heating thermo OFF	Heating thermo OFF					Display of indoor unit operating mode
215	11101011	IC7 operation mode									Display of opening pulse of outdoor SLEV and indoor LEV	
216	00011011	IC8 operation mode										
217	10011011	IC6 LEV opening pulse	0~2000								Display of opening pulse of outdoor SLEV and indoor LEV	
218	01011011	IC7 LEV opening pulse	0~2000									
219	11011011	IC8 LEV opening pulse	0~2000								Display of opening pulse of outdoor SLEV and indoor LEV	
220	00111011	IC6 TH23										
221	10111011	IC7 TH23									Display of opening pulse of outdoor SLEV and indoor LEV	
222	01111011	IC8 TH23										
223	11111011	IC6 TH22									Display of opening pulse of outdoor SLEV and indoor LEV	
224	00001111	IC7 TH22										
225	10001111	IC8 TH22									Display of opening pulse of outdoor SLEV and indoor LEV	
226	01001111	IC6 TH21										
227	11001111	IC7 TH21									Display of opening pulse of outdoor SLEV and indoor LEV	
228	00100111	IC8 TH21										
229	10100111	IC6 SC/SH									Display of indoor SC/SH data	
230	01100111	IC7 SC/SH										
231	11100111	IC8 SC/SH									Display of indoor SC/SH data	
232	00010111	IC6 target SC/SH										
233	10010111	IC7 target SC/SH									Display of indoor SC/SH data	
234	01010111	IC8 target SC/SH										
235	11010111	IC6 LEV opening pulse at abnormality delay	SCm/SHm (0.0~14.0)								Display of all control target data	
236	00110111	IC7 LEV opening pulse at abnormality delay	SCm/SHm (0.0~14.0)									
237	10110111	IC8 LEV opening pulse at abnormality delay	SCm/SHm (0.0~14.0)								Display of all control target data	
238	01110111	IC6 SC/SH at abnormality delay	SCm/SHm (0.0~14.0)									
239	11110111	IC7 SC/SH at abnormality delay	SCm/SHm (0.0~14.0)								Display of all control target data	
240	00001111	IC8 SC/SH at abnormality delay	SCm/SHm (0.0~14.0)									
241	10001111	IC6 LEV opening pulse at time of abnormality									Display of opening pulse of indoor LEV at time of abnormality	
242	01001111	IC7 LEV opening pulse at time of abnormality										
243	11001111	IC8 LEV opening pulse at time of abnormality									Display of opening pulse of indoor LEV at time of abnormality	
244	00101111	IC6 SC/SH at abnormality										
245	10101111	IC7 SC/SH at abnormality									Display of opening pulse of indoor LEV at time of abnormality	
246	01101111	IC8 SC/SH at abnormality										

This chapter provides an introduction to electrical wiring for the MULTI-S series, together with notes concerning power wiring, wiring for control (transmission wires and remote controller wires), and the frequency converter.

10-1. OVERVIEW OF POWER WIRING

- (1) Please refer to your electric power company about the indoor wiring specifications for the power wire diameter and capacity of protective devices (switches and leakage of breakers).
- (2) Taking into consideration voltage drops caused by the length of the wires when operating devices installed downstream, determine the specifications of wires able to handle the maximum current or voltage. In addition, protective devices must be able to protect against current leakage or excessive current.
- (3) It is generally necessary to include leakage breakers when installing wiring for the CITY MULTI-S series. Protective switches (excessive current protection) along main or branch lines should typically consist of fuse-less breakers (ELB).
- (4) Please perform grounding.
- (5) It is suggested that you consult with your electric power company concerning restrictions on electrical specifications.

10-2. WIRE DIAMETER AND MAIN POWER SWITCH CAPACITY

10-2-1. Wiring diagram for main power supply

• PUMY-P125VMA
PUMY-P125VMA₁

Power supply
(single phase
220-230-240V, 50Hz)

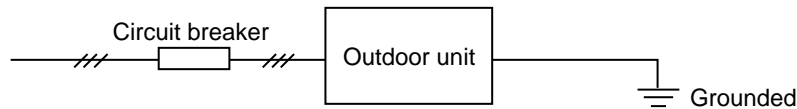

• PUMY-P125YMA
PUMY-P125YMA₁

Power supply
(3phase 380-400-415V, 50Hz)

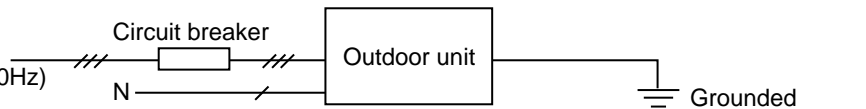

Power supply
(single phase
50Hz 220-230-240V)

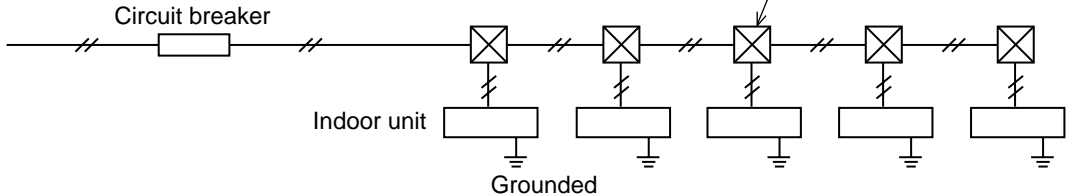

10-2-2. Power supply wire diameter and capacity

Model		Minimum wire cross section area(mm ²)			Breaker	
		Main line	Branch line	Grounded	Interrupting current	Performance characteristic
Outdoor unit	PUMY-P125VMA PUMY-P125VMA ₁	5.5(6)	—	5.5(6)	32A	32A,30mA for 0.1 sec. or less
	PUMY-P125YMA PUMY-P125YMA ₁	2.5	—	2.5	25A	25A,30mA for 0.1 sec. or less

Model		Minimum wire cross section area(mm)			Breaker	
		Main line	Branch line	Grounded	Interrupting current	Performance characteristic
Indoor unit	All Models	φ1.6	—	φ1.6	15A	15A, 30mA for 0.1 sec. or less

10-3. DESIGN FOR CONTROL WIRING

Please note that the types and numbers of control wires needed by the CITY MULTI-S series will depend on the remote controllers and whether they are linked with the system.

10-3-1. Selection number of control wires

		M-NET remote controller
Use		Remote controller used in system control operations. • Group operation involving different refrigerant systems. • Linked operation with upper control system.
Remote controller → indoor unit		2 wires (non-polar)
Transmission wires	Wires connecting → indoor units	
	Wires connecting → indoor units with outdoor unit	
	Wires connecting → outdoor units	

10-3-2. Control signal wires

● Transmission wires

- Types of transmission cables : Shielding wire CVVS or CPEVS.
- Cable diameter : More than 1.25mm²
- Maximum wiring length : Within 200 m

10-3-3. Remote controller wiring

Kind of remote control cable	2-core cable (unshielded)
Cable diameter	0.3 to 1.25mm ²
Remarks	When 10m is exceeded, use cable with the same specifications as 10-3-2. Transmission line wiring

10-3-4. Permissible length of control wiring

- Maximum extension length of wiring (L₁+L₂+L₃+L₄).....less than 500m
- Maximum wire length (L₁+L₂+L₄ or L₁+L₃ or L₂+L₃+L₄).....less than 200m
- Remote controller wire (ℓ).....network controller wire is less than 10m

Note 1: Please make sure that the transmission wire is grounded at the outdoor unit ground terminal.

Note 2: If the remote controller wire is greater than 10m, the excess portion should use shielded wire at least 1.25mm² in size. Please make sure that the total length of the farthest wire is less than 200m.

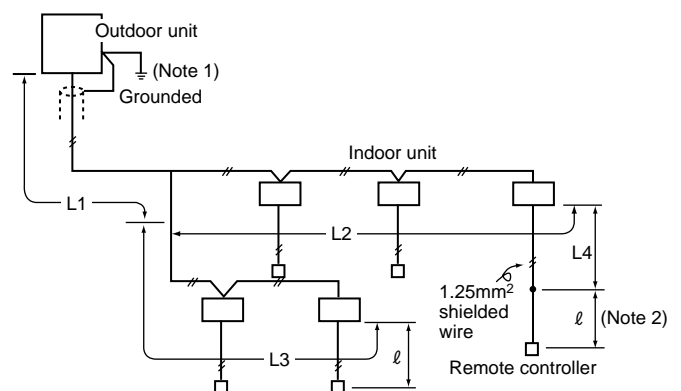

10-4. SYSTEM SWITCH SETTING

In order to identify the destinations of signals to the outdoor units, indoor units, and remote controller of the MULTI-S series, each microprocessor must be assigned an identification number (address). The addresses of outdoor units, indoor units, and remote controller must be set using their settings switches. Please consult the installation manual that comes with each unit for detailed information on setting procedures.

10-5. EXAMPLE EXTERNAL WIRING DIAGRAM FOR A BASIC SYSTEM

10-5-1. Example using a M-NET remote controller

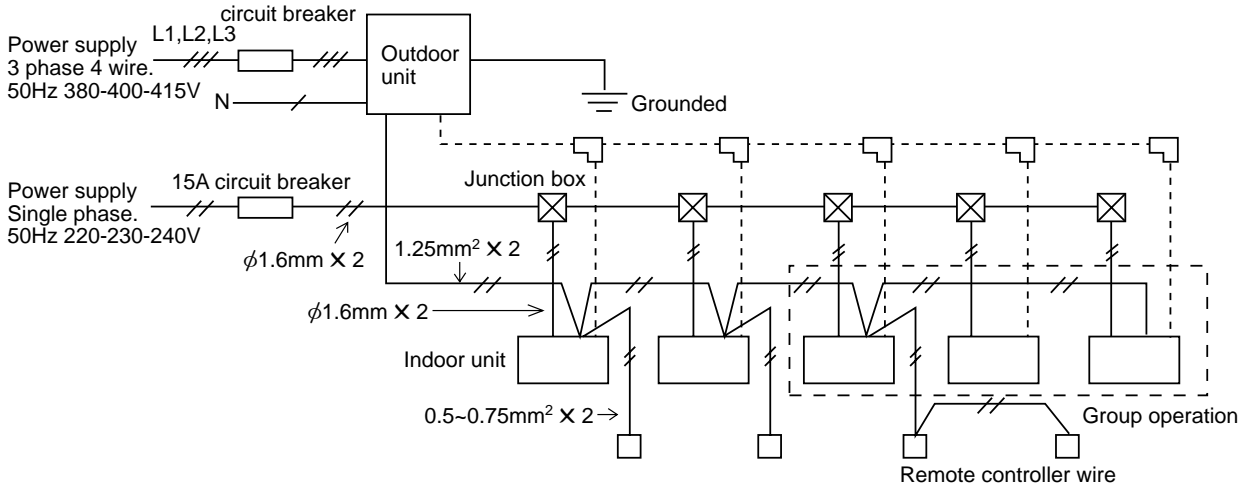

10-6. METHOD FOR OBTAINING ELECTRICAL CHARACTERISTICS WHEN A CAPACITY AGREEMENT IS TO BE SIGNED WITH AN ELECTRIC POWER COMPANY

The electrical characteristics of connected indoor unit system for air conditioning systems, including the MULTI-S series, will depend on the arrangement of the indoor and outdoor units.

First read the data on the selected indoor and outdoor units and then use the following formulas to calculate the electrical characteristics before applying for a capacity agreement with the local electric power company.

10-6-1. Obtaining the electrical characteristics of a MULTI-S series system

(1) Procedure for obtaining total power consumption

	Page numbers in this technical manual	Power consumption
Total power consumption of each indoor unit	See the technical manual of each indoor unit	①
*1 power consumption of outdoor unit	Standard capacity table—page 11-14	②
Total power consumption of system	See the technical manual of each indoor unit	①+② <kW>

*1 Please note that the power consumption of the outdoor unit will vary depends on the total capacity of the selected indoor units.

(2) Method of obtaining total current

	Page numbers in this technical manual	Subtotal
Total current through each indoor unit	See the technical manual of each indoor unit	①
*2 current through outdoor unit	Standard capacity table—page 11-14	②
Total current through system	See the technical manual of each indoor unit	①+② <A>

*2 Please note that the current through the outdoor unit will vary depending on the total capacity of the selected indoor units.

(3) Method of obtaining system power factor

Use the following formula and the total power and current obtained in parts ① and ② on the previous page to calculate the system power factor.

$$\text{System power factor} = \frac{(\text{Total system power consumption})}{(\text{Total system current} \times \text{voltage})} \times 100\%$$

10-6-2. Applying to an electric power company for power and total current

Calculations should be performed separately for heating and cooling employing the same methods; use the largest resulting value in your application to the electric power company.

11-1. REFRIGERANT PIPING SYSTEM

Line-Branch Method

Connection Examples
(Connecting to Four Indoor Units)

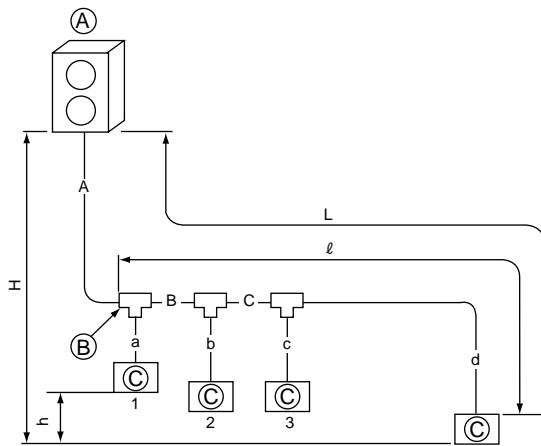

- (A) Outdoor Unit
- (B) First Branch
- (C) Indoor unit

Permissible Length	Total Piping Length	A+B+C+a+b+c+d is 100 meters or less
	Farthest Piping Length (L)	A+B+C+d is 70 meters or less
	Farthest Piping Length After First Branch (ℓ)	B+C+d is 30meters or less
Permissible High/Low Difference	High/Low Difference in Indoor/Outdoor Section (H)	30 meters or less (If the outdoor unit is lower, 20 meters or less)
	High/Low Difference in Indoor/Indoor Section (h)	12 meters or less

■ **Selecting the Refrigerant Branch Kit**

Use an optional branch piping kit (CMY-Y62-C-E).

■ **Select Each Section of Refrigerant Piping**

- (1) Section From Outdoor Unit to First Branch (A)
 - (2) Sections From Branch to Indoor Unit (a,b,c,d)
 - (3) Section From Branch to Branch (B,C)
- } Each Section of Piping

Select the size from the table to the right.

- (1) Refrigerant Piping Diameter In Section From Outdoor Unit to First Branch (Outdoor Unit Piping Diameter)
- (2) Refrigerant Piping Diameter In Section From Branch to Indoor Unit (Indoor Unit Piping Diameter)

Model	Piping Diameter (mm)	
	Liquid Line	Gas Line
PUMY-P125	φ9.52	φ19.05

Model number	Piping Diameter (mm)	
	Liquid Line	Gas Line
40 or lower	φ6.35	φ12.7
	φ9.52	φ15.88
50 to 80	φ9.52	φ15.88
	φ15.88	φ19.05
100, 125	φ9.52	φ19.05
	φ19.05	φ25.4

- (3) Refrigerant Piping Diameter In Section From Branch to Branch

Downstream Unit Model Total	Liquid Line (mm)	Gas Line (mm)
80 or less	φ9.52	φ15.88
80 or more	φ9.52	φ19.05

■ **Additional refrigerant charge**

- Refrigerant of 3kg equivalent to 50-m total extended piping length is already included when the outdoor unit is shipped. Thus, if the total extended piping length is 50m or less, there is no need to charge with additional refrigerant.
- If the total extended piping length exceeds 50m, calculate the required additional refrigerant charge using the procedure shown on the right.
- If the calculated additional refrigerant charge is a negative amount, do not charge with any refrigerant.

<Additional Charge>

Additional refrigerant charge (kg)	=	Liquid pipe size Total length of φ9.52 × 0.06 (m) × 0.06 (kg/m)	+	Liquid pipe size Total length of φ6.35 × 0.024 (m) × 0.024 (kg/m)	-	Refrigerant amount for outdoor unit 125: 3.0kg
------------------------------------	---	---	---	---	---	--

<Example>

Indoor 1 : 25	A : φ9.52	10m	a : φ6.35	5m	} At the conditions below:
2 : 50	B : φ9.52	10m	b : φ9.52	10m	
3 : 25	C : φ9.52	10m	c : φ6.35	10m	
4 : 50			d : φ9.52	10m	

The total length of each liquid line is as follows
 φ9.52 : A + B + C + b + d = 10 + 10 + 10 + 10 + 10 = 50m
 φ6.35 : a + c = 5 + 10 = 15m

Therefore,
 <Calculation example>

Additional refrigerant charge = 50 × 0.06 + 15 × 0.024 – 3.0 = 0.4kg (rounded up)

Header-Branch Method
Connection Examples
(Connecting to Four Indoor Units)

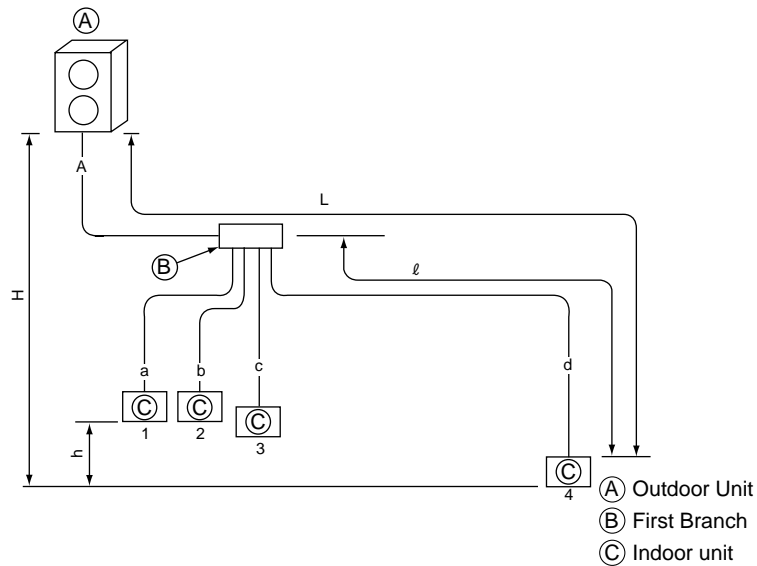

Permissible Length	Total Piping Length	A+a+b+c+d is 100 meters or less
	Farthest Piping Length (L)	A+d is 70 meters or less
	Farthest Piping Length After First Branch (ℓ)	d is 30 meters or less
Permissible High/Low Difference	High/Low Difference in Indoor/Outdoor Section (H)	30 meters or less (If the outdoor unit is lower, 20 meters or less)
	High/Low Difference in Indoor/Indoor Section (h)	12 meters or less

■ **Selecting the Refrigerant Branch Kit**

Please select branching kit, which is sold separately, from the table below.
(The kit comprises sets for use with liquid pipes and for use with gas pipes.)
•The CMY-Y68- cannot be connected with 100,125 type indoor units.

Branch header (4 branches)	Branch header (8 branches)
CMY-Y64-C	CMY-Y68

■ **Select Each Section of Refrigerant Piping**

- (1) Section From Outdoor Unit to First Branch (A)
(2) Sections From Branch to Indoor Unit (a,b,c,d)
- Each Section of Piping

Select the size from the table to the right.

(1) Refrigerant Piping Diameter In Section From Outdoor Unit to First Branch (Outdoor Unit Piping Diameter)			(2) Refrigerant Piping Diameter In Section From Branch to Indoor Unit (Indoor Unit Piping Diameter)		
Model	Piping Diameter (mm)		Model number	Piping Diameter (mm)	
PUMY-P125	Liquid Line	φ9.52	40 or lower	Liquid Line	φ6.35
	Gas Line	φ19.05		Gas Line	φ12.7
	Liquid Line	φ9.52	50 to 80	Liquid Line	φ9.52
	Gas Line	φ15.88		Gas Line	φ15.88
	Liquid Line	φ9.52	100,125	Liquid Line	φ9.52
	Gas Line	φ19.05		Gas Line	φ19.05

■ **Additional refrigerant charge**

- Refrigerant of 3kg equivalent to 50-m total extended piping length is already included when the outdoor unit is shipped. Thus, if the total extended piping length is 50m or less, there is no need to charge with additional refrigerant.
- If the total extended piping length exceeds 50m, calculate the required additional refrigerant charge using the procedure shown on the right.
- If the calculated additional refrigerant charge is a negative amount, do not charge with any refrigerant.

<Additional Charge>

Additional refrigerant charge (kg)	=	Liquid pipe size Total length of φ9.52 X 0.06 (m) X 0.06 (kg/m)	+	Liquid pipe size Total length of φ6.35 X 0.024 (m) X 0.024 (kg/m)	-	Refrigerant amount for outdoor unit 125: 3.0kg
------------------------------------	---	---	---	---	---	--

<Example>

Indoor 1 : 50	A : φ9.52	30m	a : φ9.52	15m	} At the conditions below:
2 : 40			b : φ6.35	10m	
3 : 25			c : φ6.35	10m	
4 : 20			d : φ6.35	20m	

The total length of each liquid line is as follows

φ9.52 : A + a = 30 + 15 = 45m
φ6.35 : b + c + d = 10 + 10 + 20 = 40m

Therefore,

<Calculation example>

Additional refrigerant charge = 45 x 0.06 + 40 x 0.024 - 3.0 = 0.7kg (rounded up)

Method of Combined Branching of Lines and Headers
Connection Examples
 (Connecting to Five Indoor Units)

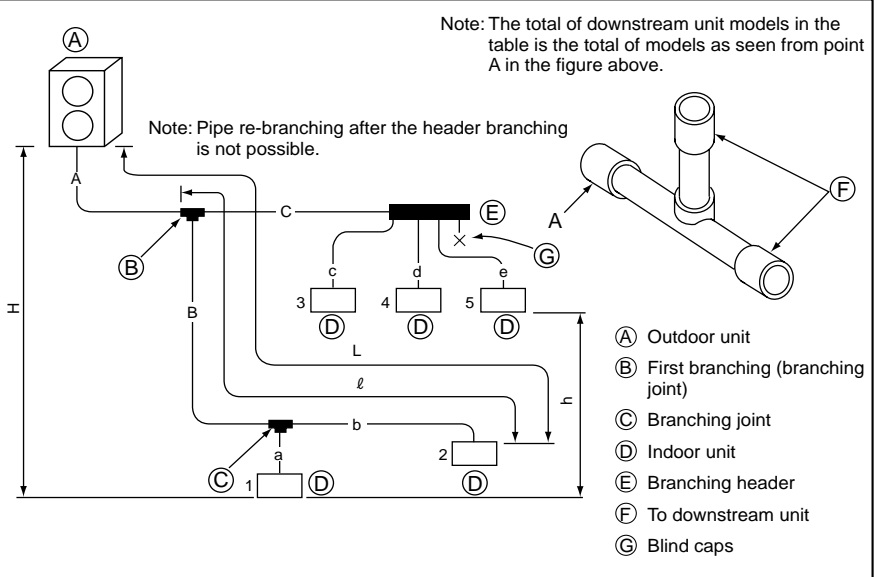

Permissible Length	Total Piping Length	A+B+C+a+b+c+d+e is 100 meters or less
	Farthest Piping Length (L)	A+B+b is 70 meters or less
	Farthest Piping Length After First Branch (ℓ)	B+b is 30 meters or less
Permissible High/Low Difference	High/Low Difference in Indoor/Outdoor Section (H)	30 meters or less (If the outdoor unit is lower, 20 meters or less)
	High/Low Difference in Indoor/Indoor Section (h)	12 meters or less

Selecting the Refrigerant Branch Kit

Please select branching kit, which is sold separately, from the table below.
 (The kit comprises sets for use with liquid pipes and for use with gas pipes.)

Branch Joint	Branch Header (4 branches)	Branch Header (8 branches)
CMY-Y62-C-E	CMY-Y64-C	CMY-Y68

Select Each Section of Refrigerant Piping

- (1) Section From Outdoor Unit to First Branch (A)
 - (2) Sections From Branch to Indoor Unit (a,b,c,d,e)
 - (3) Section From Branch to Branch (B,C)
- Each Section of Piping

Select the size from the table to the right.

(1) Refrigerant Piping Diameter In Section From Outdoor Unit to First Branch (Outdoor Unit Piping Diameter)	(2) Refrigerant Piping Diameter In Section From Branch to Indoor Unit (Indoor Unit Piping Diameter)																								
<table border="1"> <thead> <tr> <th>Model</th> <th>Piping Diameter (mm)</th> </tr> </thead> <tbody> <tr> <td rowspan="2">PUMY-P125</td> <td>Liquid Line</td> <td>φ9.52</td> </tr> <tr> <td>Gas Line</td> <td>φ19.05</td> </tr> </tbody> </table>	Model	Piping Diameter (mm)	PUMY-P125	Liquid Line	φ9.52	Gas Line	φ19.05	<table border="1"> <thead> <tr> <th>Model number</th> <th>Piping Diameter (mm)</th> </tr> </thead> <tbody> <tr> <td rowspan="2">40 or lower</td> <td>Liquid Line</td> <td>φ6.35</td> </tr> <tr> <td>Gas Line</td> <td>φ12.7</td> </tr> <tr> <td rowspan="2">50 to 80</td> <td>Liquid Line</td> <td>φ9.52</td> </tr> <tr> <td>Gas Line</td> <td>φ15.88</td> </tr> <tr> <td rowspan="2">100,125</td> <td>Liquid Line</td> <td>φ9.52</td> </tr> <tr> <td>Gas Line</td> <td>φ19.05</td> </tr> </tbody> </table>	Model number	Piping Diameter (mm)	40 or lower	Liquid Line	φ6.35	Gas Line	φ12.7	50 to 80	Liquid Line	φ9.52	Gas Line	φ15.88	100,125	Liquid Line	φ9.52	Gas Line	φ19.05
Model	Piping Diameter (mm)																								
PUMY-P125	Liquid Line	φ9.52																							
	Gas Line	φ19.05																							
Model number	Piping Diameter (mm)																								
40 or lower	Liquid Line	φ6.35																							
	Gas Line	φ12.7																							
50 to 80	Liquid Line	φ9.52																							
	Gas Line	φ15.88																							
100,125	Liquid Line	φ9.52																							
	Gas Line	φ19.05																							
(3) Refrigerant Piping Diameter In Section From Branch to Branch																									
<table border="1"> <thead> <tr> <th>Downstream Unit Model Total</th> <th>Liquid Line (mm)</th> <th>Gas Line (mm)</th> </tr> </thead> <tbody> <tr> <td>80 or less</td> <td>φ9.52</td> <td>φ15.88</td> </tr> <tr> <td>80 or more</td> <td>φ9.52</td> <td>φ19.05</td> </tr> </tbody> </table>	Downstream Unit Model Total	Liquid Line (mm)	Gas Line (mm)	80 or less	φ9.52	φ15.88	80 or more	φ9.52	φ19.05																
Downstream Unit Model Total	Liquid Line (mm)	Gas Line (mm)																							
80 or less	φ9.52	φ15.88																							
80 or more	φ9.52	φ19.05																							

Additional refrigerant charge

- Refrigerant of 3kg equivalent to 50-m total extended piping length is already included when the outdoor unit is shipped. Thus, if the total extended piping length is 50m or less, there is no need to charge with additional refrigerant.
- If the total extended piping length exceeds 50m, calculate the required additional refrigerant charge using the procedure shown on the right.
- If the calculated additional refrigerant charge is a negative amount, do not charge with any refrigerant.

<Additional Charge>

Additional refrigerant charge (kg)	=	Liquid pipe size Total length of φ9.52 X 0.06 (m) X 0.06 (kg/m)	+	Liquid pipe size Total length of φ6.35 X 0.024 (m) X 0.024 (kg/m)	-	Refrigerant amount for outdoor unit 125: 3.0kg
------------------------------------	---	---	---	---	---	--

<Example>

Indoor 1 : 50	A : φ9.52	10m	a : φ9.52	5m	} At the conditions below:
2 : 40	B : φ9.52	20m	b : φ6.35	10m	
3 : 32	C : φ9.52	10m	c : φ6.35	5m	
4 : 20			d : φ6.35	5m	
5 : 20			e : φ6.35	5m	

The total length of each liquid line is as follows
 φ9.52 : A + B + C + a = 10 + 20 + 10 + 5 = 45m
 φ6.35 : b + c + d + e = 10 + 5 + 5 + 5 = 25m
 Therefore,
 <Calculation example>
 Additional refrigerant charge = 45 × 0.06 + 25 × 0.024 - 3.0 = 0.3kg (rounded up)

Multi-distribution piping on outdoor unit
 Connection Examples
 (Connecting up to Five Indoor Units)

*If multi-distribution piping on outdoor unit is done, a maximum of 5 indoor units can be connected.

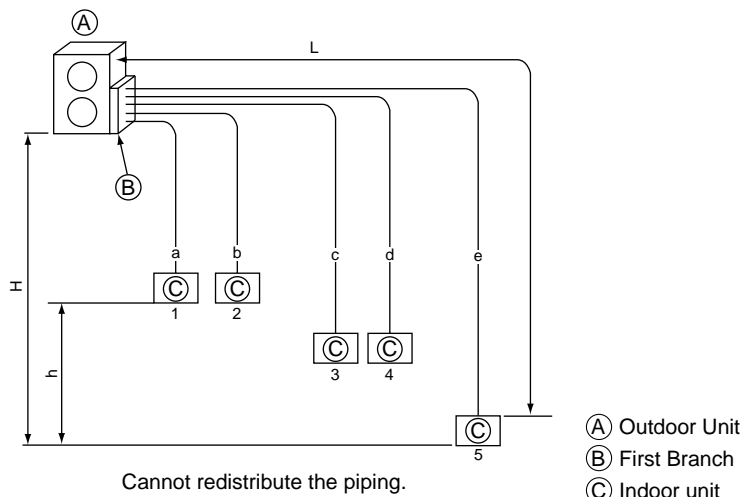

Permissible Length	Total Piping Length	a+b+c+d+e is 100 meters or less
	Farthest Piping Length (L)	e is 30 meters or less
Permissible High/Low Difference	High/Low Difference in Indoor/Outdoor Section (H)	30 meters or less (20 meters or less if the outdoor unit is below.)
	High/Low Difference in Indoor/Indoor Section (h)	12 meters or less

■ **Selecting the Refrigerant Branch Kit**
 Use multi-distribution piping on outdoor unit kit CMY-S65 (5 branches).
 *Cannot be connected with 100,125 type indoor units.

■ **Select Each Section of Refrigerant Piping**
 • Section the piping size for each section from the branch to the indoor unit (a,b,c,d,e) using the chart on the right.

• Refrigerant Piping Diameter In Section From Branch to Indoor Unit (Indoor Unit Piping Diameter)

Model number	Piping Diameter (mm)	
40 or lower	Liquid Line	φ6.35
	Gas Line	φ12.7
50 to 80	Liquid Line	φ9.52
	Gas Line	φ15.88

■ **Additional refrigerant charge**

- Refrigerant of 3kg equivalent to 50-m total extended piping length is already included when the outdoor unit is shipped. Thus, if the total extended piping length is 50m or less, there is no need to charge with additional refrigerant.
- If the total extended piping length exceeds 50m, calculate the required additional refrigerant charge using the procedure shown on the right.
- If the calculated additional refrigerant charge is a negative amount, do not charge with any refrigerant.

<Additional Charge>

Additional refrigerant charge	=	Liquid pipe size Total length of φ9.52 X 0.06	+	Liquid pipe size Total length of φ6.35 X 0.024	-	Refrigerant amount for outdoor unit
(kg)		(m) X 0.06 (kg/m)		(m) X 0.024 (kg/m)		125: 3.0kg

<Example>

- Indoor 1 : 20 a : φ6.35 10m
- 2 : 20 b : φ6.35 20m
- 3 : 20 c : φ6.35 20m
- 4 : 50 d : φ9.52 20m
- 5 : 50 e : φ9.52 30m

The total length of each liquid line is as follows

φ9.52 : d + e = 20 + 30 = 50m

φ6.35 : a + b + c = 10 + 20 + 20 = 50m

Therefore,

Additional refrigerant charge = 50 x 0.06 + 50 x 0.024 - 3.0 = 1.2kg (rounded up)

11-2. PRECAUTIONS AGAINST REFRIGERANT LEAKAGE

11-2-1. Introduction

R-22 refrigerant of this air conditioner is non-toxic and non-flammable but leaking of large amount from an indoor unit into the room where the unit is installed may be deleterious. To prevent possible injury, the rooms should be large enough to keep the R407C concentration specified by KHK : (a high pressure gas safety association) installation guidelines S0010 as follows.

*** Maximum concentration**

Maximum refrigerant concentration of R407C of a room is 0.31 kg/m³ accordance with the installation guidelines. To facilitate calculation, the maximum concentration is expressed in units of kg/m³ (kg of R407C per m³)

Maximum concentration of R407C: 0.31kg/m³

(KHK installation guidelines S0010)

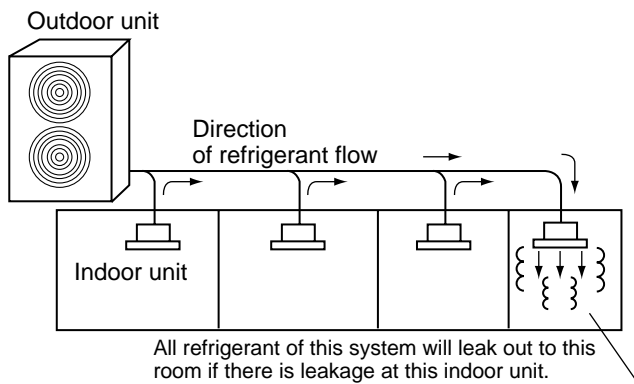

11-2-2. Confirming procedure of R407C concentration

Follow 1) to 4) to confirm the R407C concentration and take appropriate treatment, if necessary.

(1) Calculate total refrigerant amount by each refrigerant system based on one indoor unit.

Total refrigerant amount is precharged refrigerant amount of the indoor unit at ex-factory plus additional charged amount at field installation.

Note:

When single refrigeration system is consists of several independent refrigeration circuit, figure out the total refrigerant amount by each independent refrigerant circuit.

(2) Calculate room volumes (in m³) and find the room with the smallest volume

The part with represents the room with the smallest volume.

(a) Situation in which there are no partitions

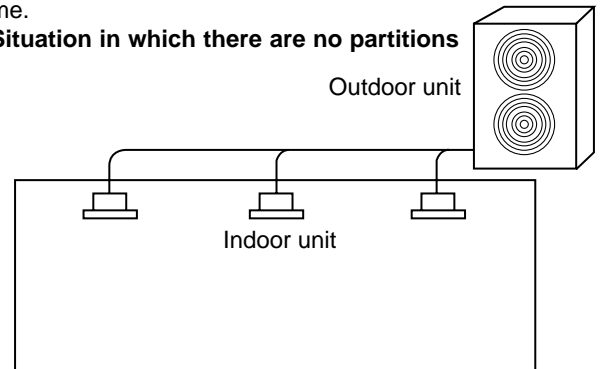

(b) There are partitions, but there are openings that allow the effective mixing of air.

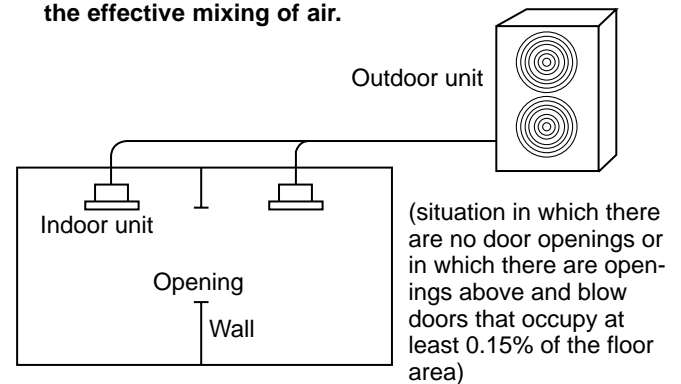

(c) If the smallest room has mechanical ventilation apparatus that is linked to a household gas detection and alarm device, the calculations should be performed for the second smallest room.

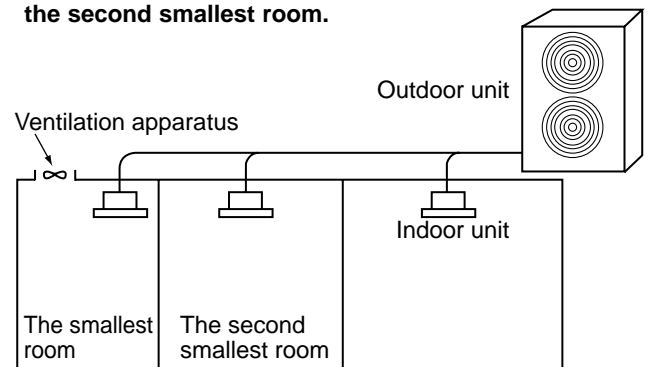

(3) Use the results of calculations (1) and (2) to calculate the refrigerant concentration:

$$\frac{\text{Total refrigerant in the refrigerating unit (kg)}}{\text{The smallest room in which an indoor unit has been installed (m}^3\text{)}} \leq \text{maximum concentration (kg/m}^3\text{)}$$

Maximum concentration of R407C: 0.31kg/m³

If the calculation results do not exceed the maximum concentration, perform the same calculations for the larger second and third room, etc., until it has been determined that nowhere will the maximum concentration be exceeded.

Service Ref. : PUMY-P125VMA
 PUMY-P125VMA₁
 PUMY-P125YMA
 PUMY-P125YMA₁

* 1. Please pay attention to safety when assembling or disassembling heavy items.
 2. The refrigerant system must be vacuum-pumped before performing piping maintenance.

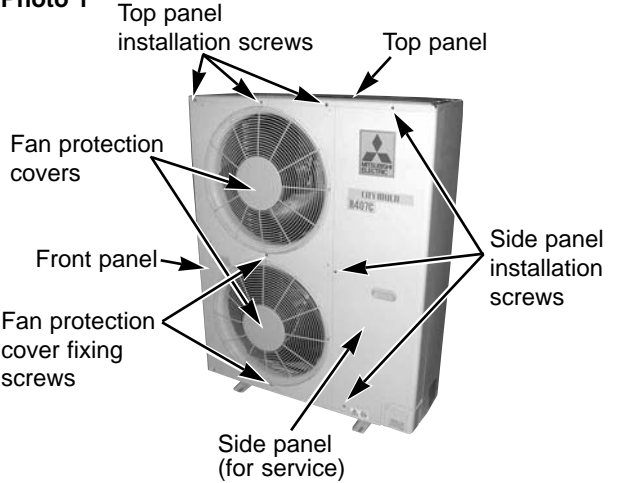
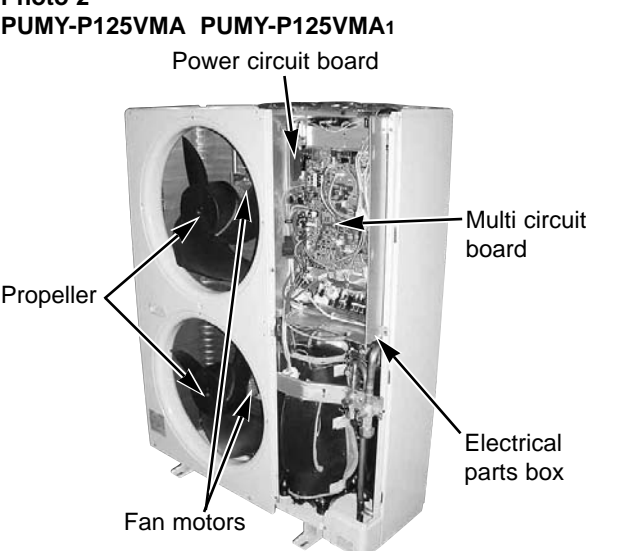
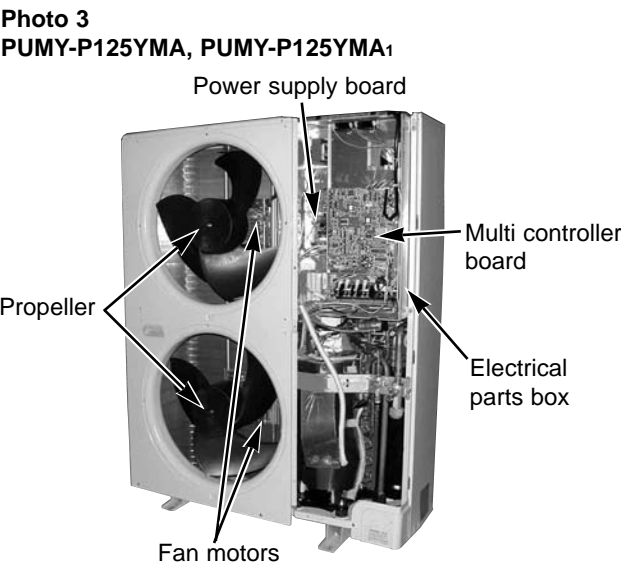
OPERATING PROCEDURE	PHOTOS
<p>1. Side and top panel disassembly procedures:</p> <p>(1) Remove the side panel screws (3 pcs : 5×10 screws) so that the hanging portion on the right side can be slid downward. Remove the side panel.</p> <p>(2) Remove the top panel screws (5×10 screws : 3 pcs in front, 2 pcs in back) and take off the top panel. <If the rear screws on the top panel cannot be removed> Remove the front screws on the top panel (3 pcs : 5×10 screws) and lift up the front part of the top panel.</p>	<p>Photo 1</p>  <p>Labels in Photo 1: Top panel installation screws, Top panel, Fan protection covers, Front panel, Side panel installation screws, Fan protection cover fixing screws, Side panel (for service).</p>
<p>2. Propeller and fan motor disassembly procedures:</p> <p>(1) Remove the side panel (See photo 1)</p> <p>(2) Remove the top panel (See photo 1)</p> <p>(3) Remove the fan protection cover fixing screw (1 pc : 15×15), and take off the fan guard by rotating it to the left.</p> <p>(4) [PUMY-P125VMA, PUMY-P125VMA₁] Remove the fan motor wires (MF1) (MF2) from the multi circuit board. Remove the capacitor wires.</p> <p>[PUMY-P125YMA, PUMY-P125YMA₁] Remove the fan motor wires (MF1) (MF2) from the power supply board. Remove the capacitor wires.</p> <p>(5) Loosen the fan motor wire clips (3 pcs).</p> <p>(6) Remove the propeller.</p> <p>(7) Remove the fan motor screws (3 pcs : 5×16 screws) and remove the fan motors.</p>	<p>Photo 2 PUMY-P125VMA PUMY-P125VMA₁</p>  <p>Labels in Photo 2: Power circuit board, Multi circuit board, Propeller, Fan motors, Electrical parts box.</p> <p>Photo 3 PUMY-P125YMA, PUMY-P125YMA₁</p>  <p>Labels in Photo 3: Power supply board, Multi controller board, Propeller, Fan motors, Electrical parts box.</p>



OPERATING PROCEDURE

3. Thermistor (TH6: outdoor air temperature sensor detection) disassembly procedures:

- (1) Remove the side panel (See photo 1)
- (2) Remove the top panel (See photo 1)
- (3) Remove the thermistor holder fixing screw (1 pc : 4×10), and remove the thermistor holder.
- (4) Remove the Thermistor (outdoor air temperature detection).
- (5) Remove the TH6 wire from the multi-functional controller board in the electrical box and pull out of the electrical box.

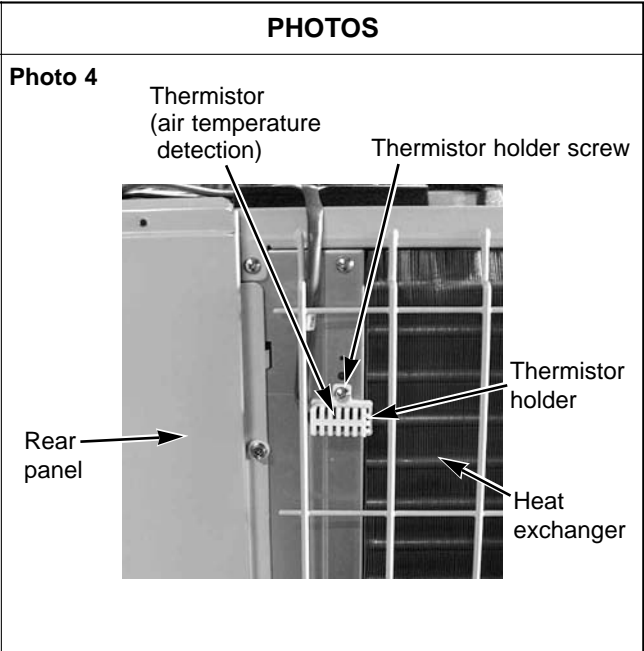

4. Electrical parts box disassembly procedures: [PUMY-P125VMA PUMY-P125VMA₁]

- (1) Remove the side panel (See photo 1)
- (2) Remove the top panel (See photo 1)
- (3) Disconnect the following wires from the multi controller board.
 - Thermistor (Discharge temperature detection):TH1
 - Thermistor (Low pressure saturated temperature detection):TH2
 - Thermistor (Pipe temperature defection / Judging defrost):TH5
 - Thermistor (Outdoor temperature detection): TH6
 - High-pressure sensor (Discharge pressure detection): 63HS
 - Expansion valve: LEV(A)
 - Fan motor: MF1 and MF2
 - Solenoid valve coil: SV
 - 4-way valve coil: 21S4
- (4) Remove the board plate.
Pull wires out of the electrical parts box after disconnecting them.
- (6) After removing the connector cover, remove the compressor wire and the inner thermostat terminal.
- (7) Remove the electrical box screw (1 pc : 4 × 10).
- (8) Remove the valve bed screws from the right side of the valve bed (2 pcs : 4 × 10).
- (9) Remove the electrical box after slightly loosening the rear panel. The electrical box is held by two claws on the left and one on the right.

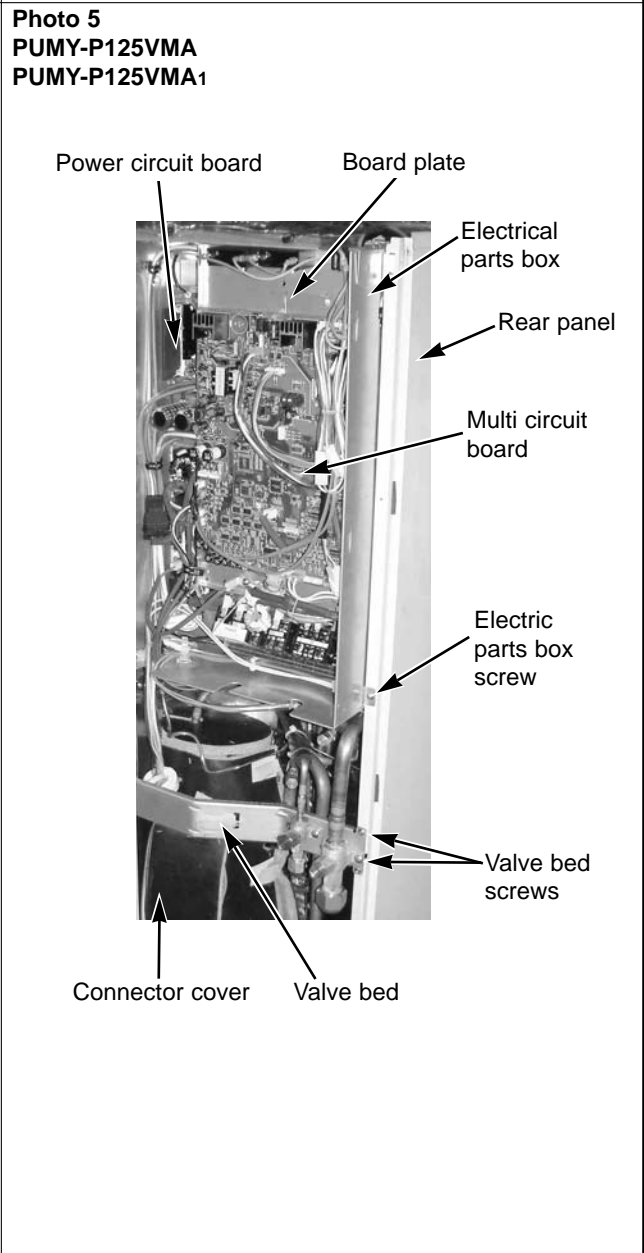



OPERATING PROCEDURE	PHOTOS
---------------------	--------

5. Electrical parts box disassembly procedures:
[PUMY-P125YMA PUMY-P125YMA₁]

- (1) Remove the side panel (See photo 1)
- (2) Remove the top panel (See photo 1)
- (3) Disconnect the following wires from the multi controller board.
 - Thermistor (Discharge temperature detection): TH1
 - Thermistor (Low pressure saturated temperature detection): TH2
 - Thermistor (Pipe temperature deflection • judging defrost): TH5
 - Thermistor (Outdoor temperature detection): TH6
 - High-pressure sensor (Discharge pressure detection): 63HS
 - Expansion valve: SLEV
- (4) Remove the board plate.
- (5) Disconnect the following wires from the power supply board:
 - Fan motor: MF1 and MF2
 - Solenoid valve: SV1
 - 4-way valve: 21S4
 Pull wires out of the electrical box after disconnecting them.
- (6) After removing the connector cover, remove the compressor wire and the inner thermostat terminal.
- (7) Remove the electrical box screw (1 pc : 4 × 10).
- (8) Remove the valve bed screws from the right side of the valve bed (2 pcs : 4 × 10).
- (9) Remove the electrical box after slightly loosening the rear panel. The electrical box is held by two claws on the left and one on the right.

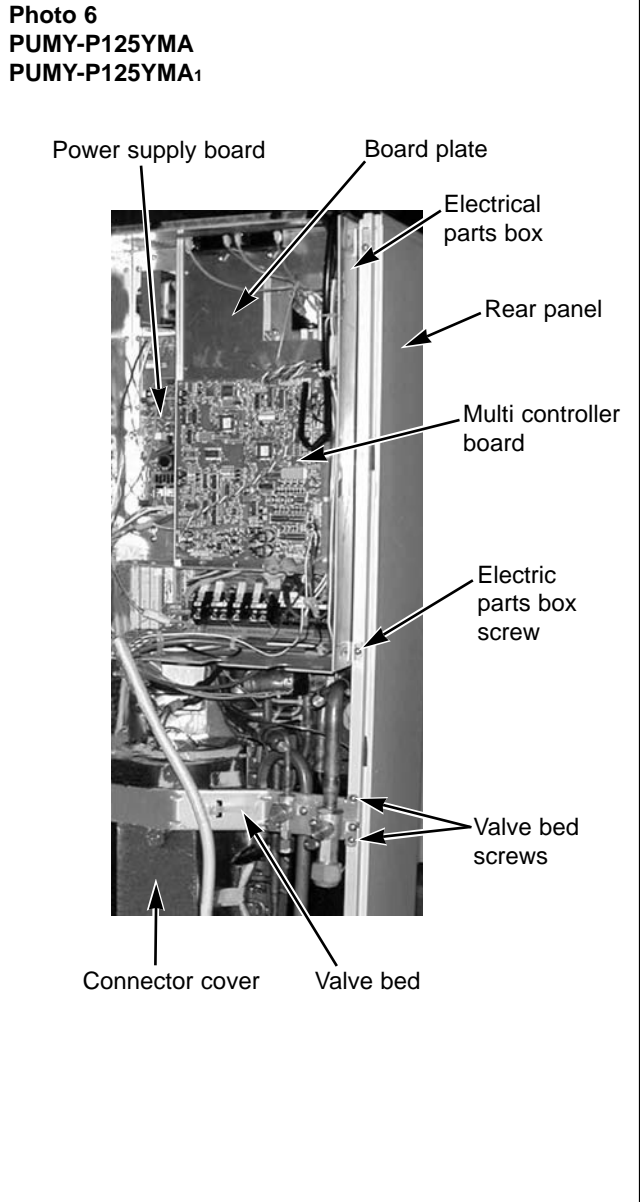

6. Solenoid valve coil and 4-way valve coil disassembly procedures:

- (1) Remove the side panel (See photo 1).
- (2) Remove the top panel (See photo 1).
- (3) Remove the electrical parts box (See photo 5 or 6).
- (4) Remove coil screws (Solenoid valve: 1 pc M4x6; 4-way valve: 1 pc M5x6), and remove the solenoid valve coil (SV1) and 4-way valve coil (21S4) wires from the power supply board.

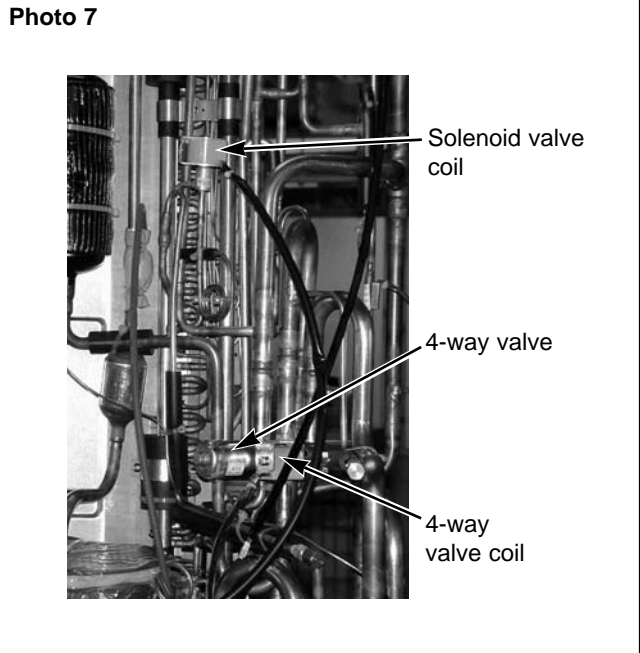



OPERATING PROCEDURE

PHOTOS

7. Thermistor disassembly procedures:

- (1) Remove the side panel (See photo 1)
- (2) Remove the top panel (See photo 1)
- (3) Remove the electrical parts box (See photo 5 or 6)
- (4) Recover gas from the refrigerant circuit.
- (5) Remove the Thermistor
(discharge temperature detection: TH1),
(Low pressure saturated temperature detection: TH2),
(Pipe temperature detection / judging defrost: TH5).
* To remove TH1, cut the bands holding it and remove the piping cover.

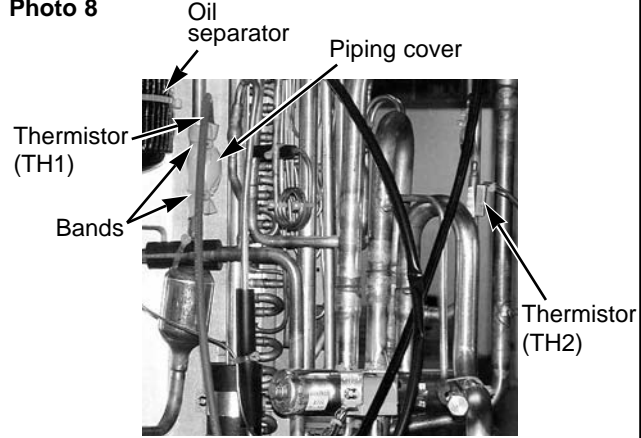

8. Compressor disassembly procedures:

- (1) Remove the side panel (See photo 1)
- (2) Remove the top panel (See photo 1)
- (3) Remove the screws (2 pcs : 5×10, 1 pc : 4×10) and the front panel.
- (4) Remove the electrical parts box (See photo 5 or 6).
- (5) Remove screws (3 pcs : 4×10, 4 pcs : 5×16) and the valve bed (including the ball valve mounting portion).
- (6) Recover gas from the refrigerant circuit.
- (7) Remove the separator screw. (1 pc : 4×10)
- (8) Remove the welded portions of the compressor discharge and intake pipes.
- (9) Remove the compressor leg cover on the separator side.
- (10) Remove the compressor leg mounting nuts (3 pcs). (use an adjustable wrench)
- (11) Move the separator to the left and remove the compressor.

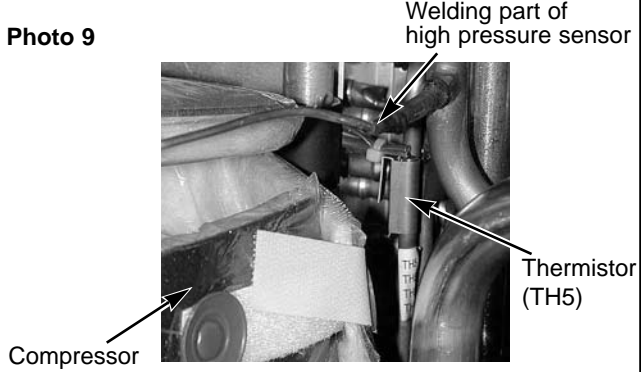

9. Accumulator disassembly procedures:

- (1) Remove the compressor (See photo 10).
- (2) Remove the welded portions of the accumulator.
- (3) Lift up the accumulator and pull it out from the rear.

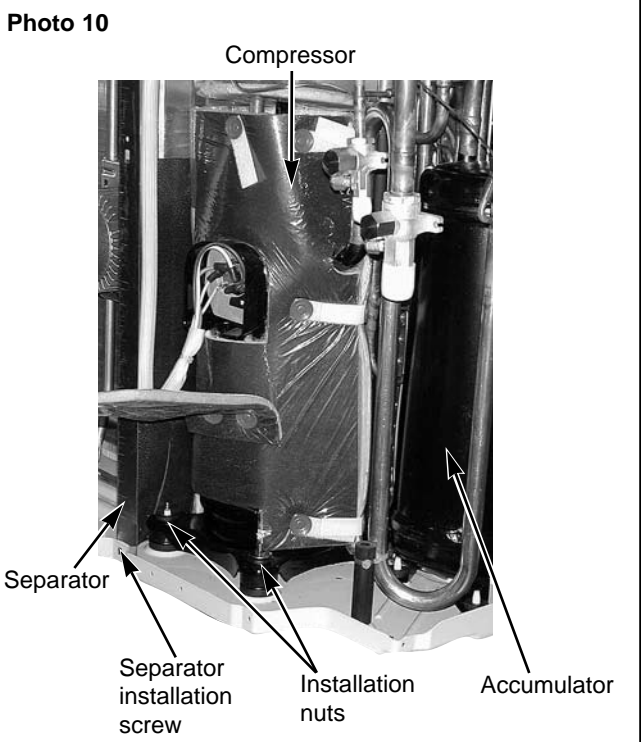

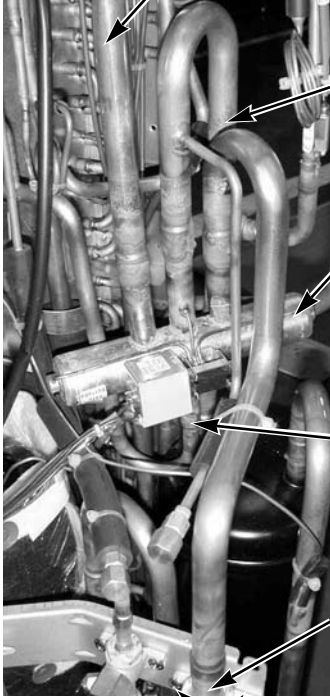
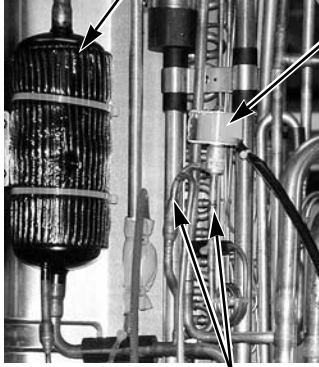
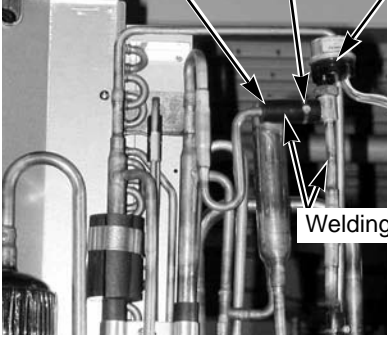

OPERATING PROCEDURE	PHOTOS
<p>10. Four-way valve disassembly procedures:</p> <ol style="list-style-type: none"> (1) Remove the side panel (See photo 1). (2) Remove the top panel (See photo 1). (3) Remove the electrical parts box (See photo 5 or 6). (4) Recover gas from the refrigerant circuit. (5) Remove the 4-way valve coil (See photo 7). (6) Remove the mounting screws from the gas side ball valve (2 pcs : 5×16). (7) Remove the field piping from the outdoor unit (gas side). (8) Remove the welded portion. <ol style="list-style-type: none"> ① Upper and lower heat exchanger inlet (T connector). ② Accumulator inlet (T connector) ③ 4-way valve inlet (9) Remove 4-way valve. <ul style="list-style-type: none"> * Do not expose 4-way valve to above 120°C. 	<p>Photo 11</p>  <p>Pipe of heat exchanger inlet (T connector)</p> <p>Accumulator inlet (T connector)</p> <p>4-way valve</p> <p>4-way valve inlet</p> <p>Gas side ball valve</p> <p>Fixing screws</p>
<p>11. Solenoid valve disassembly procedures:</p> <ol style="list-style-type: none"> (1) Remove the side panel (See photo 1). (2) Remove the electrical parts box (See photo 5 or 6). (3) Recover gas from the refrigerant circuit. (4) Remove the solenoid valve coil (See photo 7). (5) Remove the welded portions of the solenoid valve. (take care excessive heating) 	<p>Photo 12</p>  <p>Oil separator</p> <p>Solenoid valve coil</p> <p>Welding parts</p>
<p>12. Expansion valve disassembly procedures:</p> <ol style="list-style-type: none"> (1) Remove the side panel (See photo 1). (2) Remove the electrical parts box (See photo 5 or 6). (3) Recover gas from the refrigerant circuit. (4) Remove welded portions of expansion valve. (take care excessive heating) <ul style="list-style-type: none"> * To remove welded portion, cut the band holding it and remove the rubber tube. 	<p>Photo 13</p>  <p>Rubber tube</p> <p>Band</p> <p>Expansion valve</p> <p>Welding parts</p>



OPERATING PROCEDURE

13. High pressure sensor (63HS)disassembly procedures:

- (1) Remove the side panel (See photo 1).
- (2) Remove the high pressure sensor wire.
- (3) Recover gas from the refrigerant circuit.
- (4) Remove the welded portion of high pressure sensor.
- (5) Remove the mounting screw fastening the high pressure sensor mounting plate (1 pc : 4×10).
- (6) Remove the high pressure sensor mounting screws (2 pcs : 4×10).

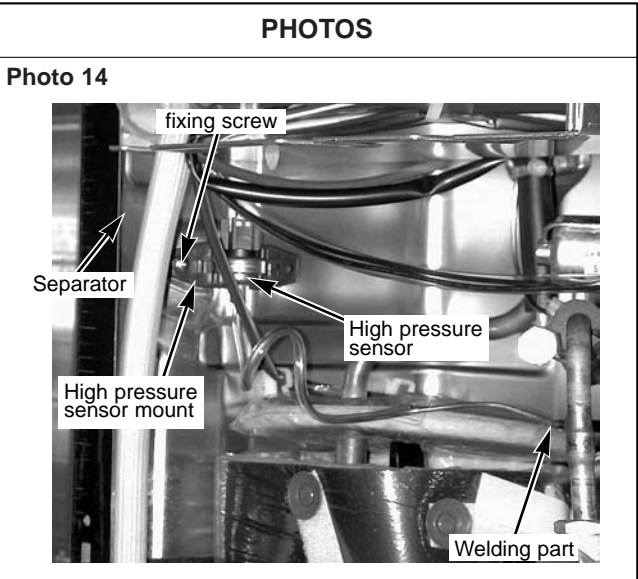

14. Capillary tube disassembly procedures:

- (1) Remove the side panel (See photo 1).
- (2) Remove the top panel (See photo 1).
- (3) Remove the electrical parts box (See photo 5 or 6).
- (4) Recover gas from the refrigerant circuit.
- (5) Remove the field piping from the unit (liquid side)
- (6) Remove the welded portions of capillary tube.
* To remove welded portions, cut the band holding it and remove the rubber tube.

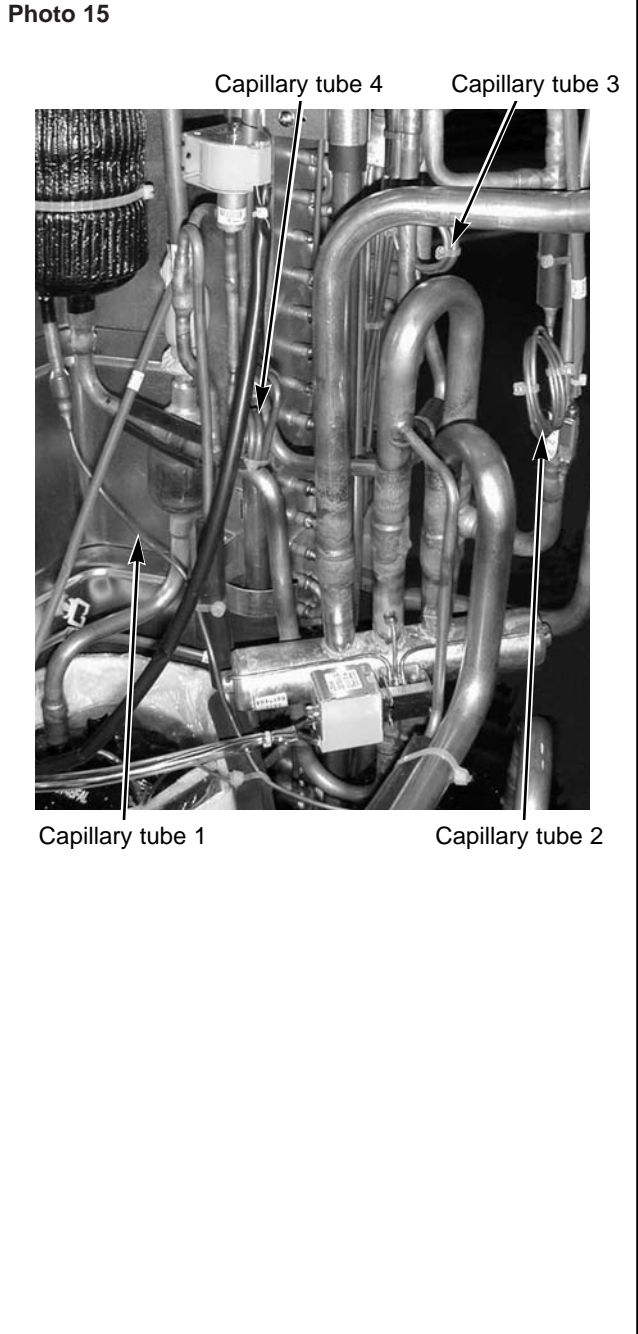

ELECTRICAL PARTS
PUMY-P125VMA
PUMY-P125VMA₁

* The illustration below is of PUMY-P125VMA

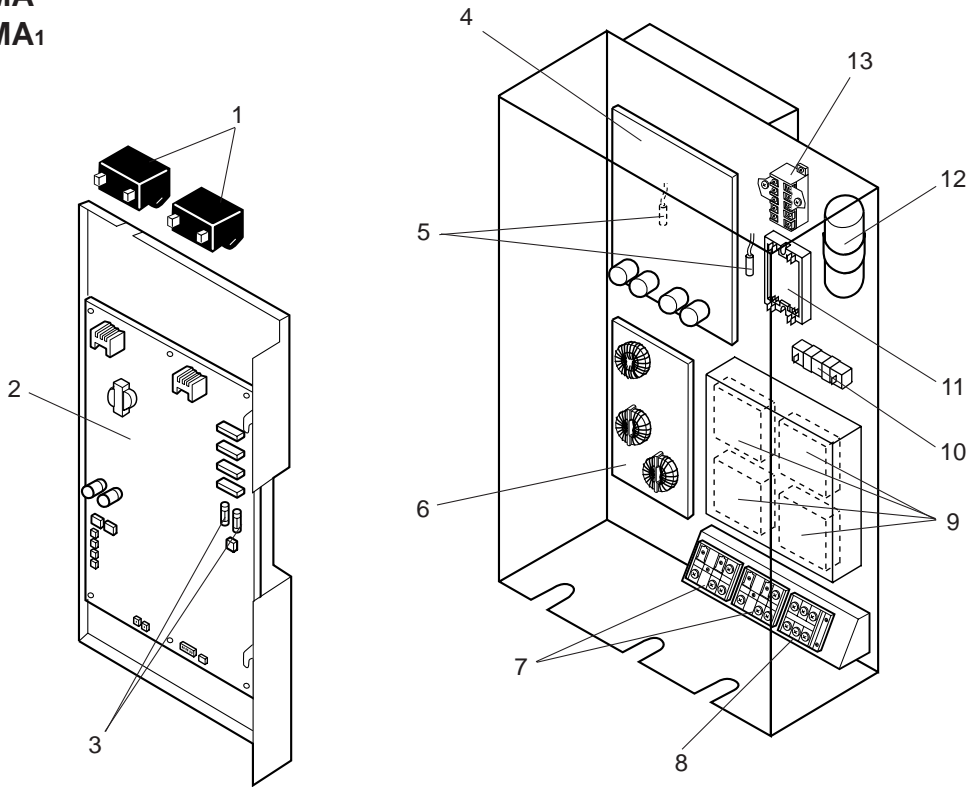

No.	Part No.	Part Name	Specification	Q'ty/set		Remarks (Drawing No.)	Wiring Diagram Symbol	Recom- mended Q'ty	Price	
				PUMY-P 125VMA	125VMA ₁				Unit	Amount
1	R01 580 255	FAN MOTOR CAPACITOR	3.5 μ F 440VAC	2	2		C1,2			
2	T7W E19 315	MULTI CIRCUIT BOARD		1	1		M.B.			
3	T7W 520 239	FUSE	6.3A 250V	2	2		F1, F2			
4	T7W E08 313	POWER CIRCUIT BOARD		1	1		P.B.			
5	R01 E65 202	THERMISTOR (RADIATOR PANEL)		2	2		THHS A/B			
6	T7W E04 346	NOISE FILTER CIRCUIT BOARD		1	1		N.F.			
7	T7W A12 716	TERMINAL BLOCK	3P(M1, M2, S)	2	2		TB3,7			
8	T7W A13 716	TERMINAL BLOCK	3P(L, N, ⊕)	1	1		TB1			
9	T7W E01 259	REACTOR		4			DCL1,2,3,4			
	TW7 E04 259	REACTOR			2		DCL1,2			
10	T7W E01 234	RESISTOR (RUSH CURRENT PROTECTION)		1	1		RS			
11	T7W E00 233	ACTIVE FILTER MODULE		1	1		ACTM			
12	T7W E05 254	SMOOTHING CAPACITOR	1,600 μ / 400WV	1	1		CE			
13	T7W E02 259	MAGNETIC CONTACTOR	S-U12 230V	1	1		52C			

ELECTRICAL PARTS
PUMY-P125YMA
PUMY-P125YMA₁

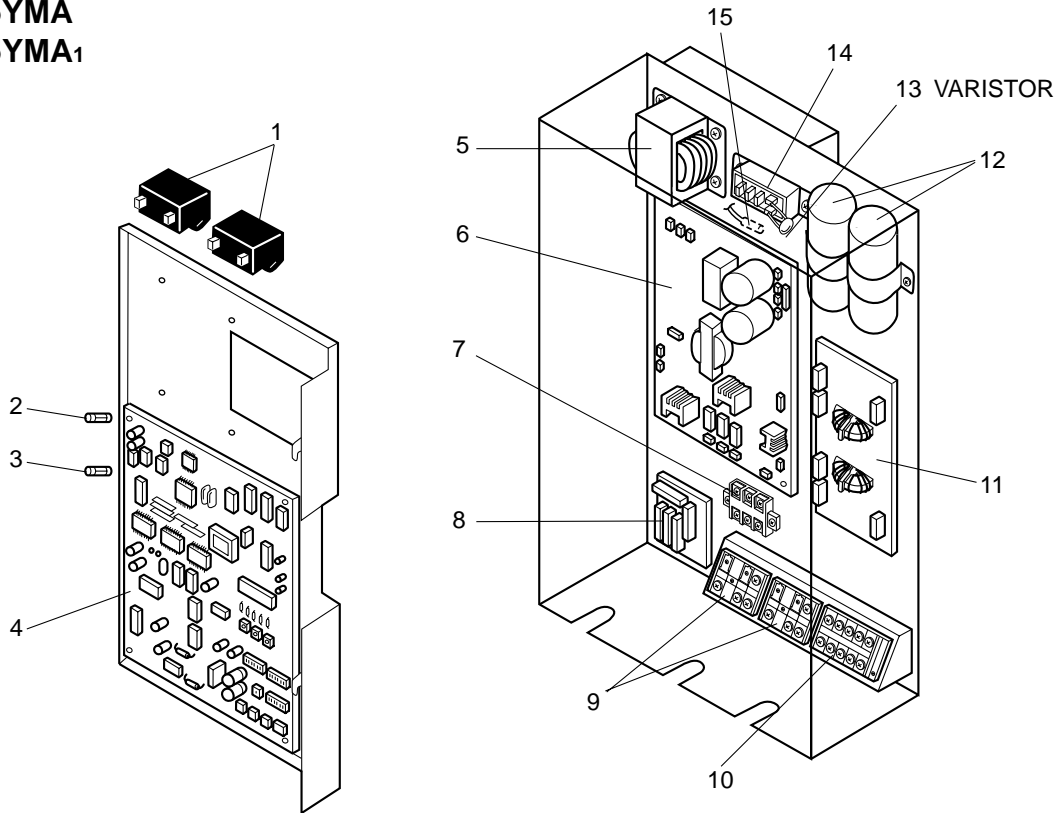

No.	Part No.	Part Name	Specification	Q'ty/set		Remarks (Drawing No.)	Wiring Diagram Symbol	Recom- mended Q'ty	Price	
				PUMY-P125 YMA	YMA ₁				Unit	Amount
1	R01 580 255	FAN MOTOR CAPACITOR	3.5 μ F 440VAC	2	2		C1,2			
2	T7W E02 239	FUSE	2A 250V	1	1		FUSE2			
3	T7W 520 239	FUSE	6.3A 250V	1	1		FUSE1			
4	T7W E11 315	MULTI CONTROLLER BOARD		1						
	T7W E18 315	MULTI CONTROLLER BOARD			1					
5	T7W E00 259	REACTOR		1	1		DCL			
6	T7W E00 311	POWER SUPPLY BOARD		1	1					
7	T7W 249 708	MAGNETIC CONTACTOR	S-U12 230V	1	1		52C			
8	T7W E00 234	RESISTOR BOARD		1	1					
9	T7W A12 716	TERMINAL BLOCK	3P(M1,M2,S)	2	2		TB3,7			
10	T7W E10 716	TERMINAL BLOCK	5P(L1,L2,L3,N,⊕)	1	1		TB1			
11	T7W E01 346	NOISE FILTER		1	1		NF			
12	T7W E03 254	CAPACITOR		2	2		C03			
13	T7W E00 349	VARISTOR		1	1		ZNR			
14	T7W E00 292	DIODE MODULE		1	1		DM			
15	R01 36A 202	THERMISTOR (IPM RADIATOR PANEL)		1	1		THHS			

FUNCTIONAL PARTS
PUMY-P125VMA
PUMY-P125VMA₁
PUMY-P125YMA
PUMY-P125YMA₁

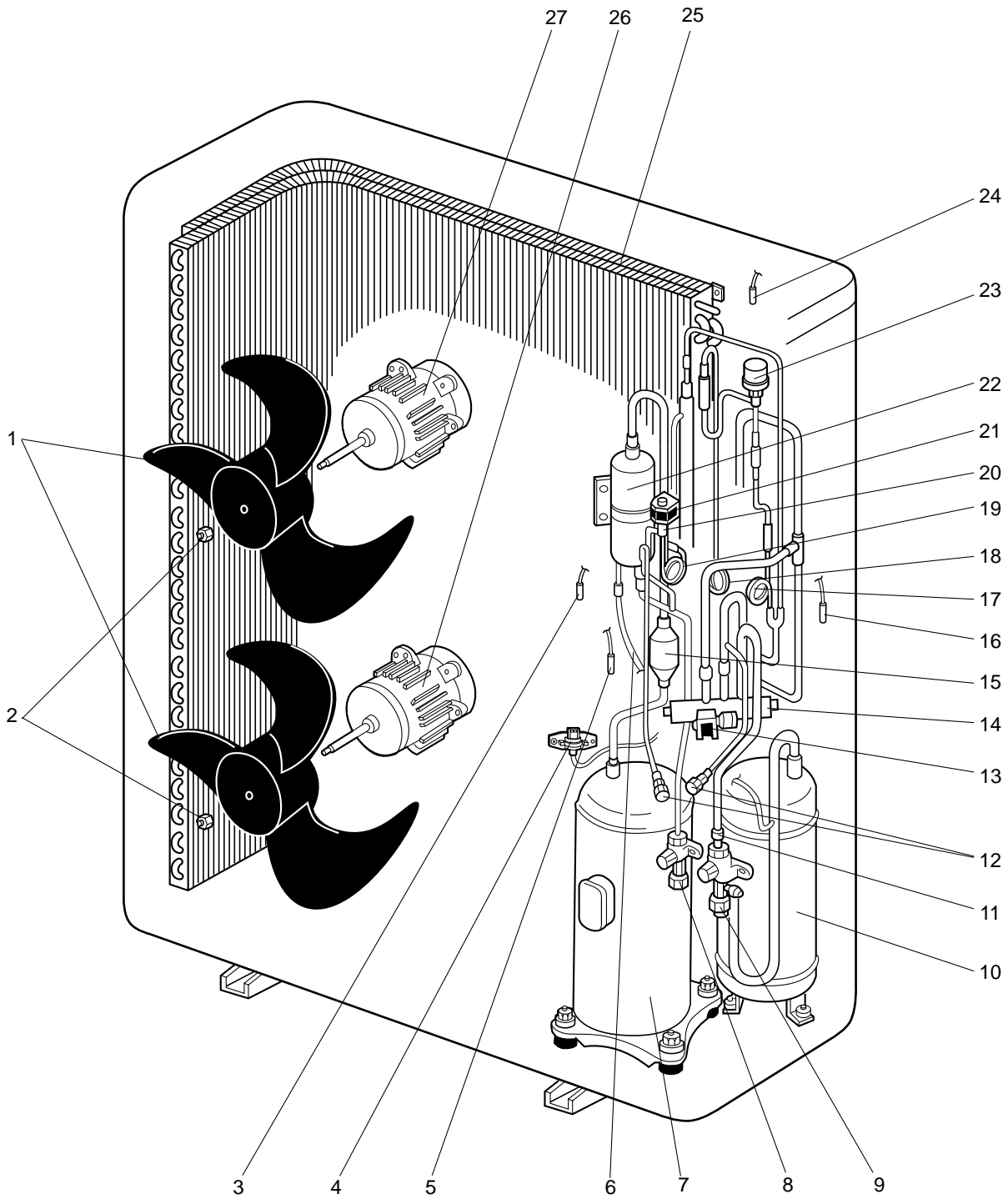



Part number that is circled is not shown in the figure.

No.	Part No.	Part Name	Specification	Q'ty/set			Remarks (Drawing No.)	Wiring Diagram Symbol	Recom- mended Q'ty	Price	
				PUMY-P125						Unit	Amount
				VMA VMA ₁	YMA	YMA ₁					
1	R01 KL5 115	PROPELLER		2	2	2					
2	R01 30L 097	NUT	M8	2	2	2					
3	R01 35A 202	THERMISTOR (DISCHARGE TEMPERATURE DETECTION)		1	1	1		TH1			
4	R01 E00 268	HIGH PRESSURE SENSOR	3.0MPa	1	1	1		63HS			
5	R01 E30 202	THERMISTOR (PIPE TEMPERATURE DETECTION / JUDGING DEFROST)		1	1	1		TH5			
6	R01 J01 425	CAPILLARY TUBE 1	$\phi 2.5 \times \phi 0.6 \times 500\text{mm}$	1	1	1					
7	T97 500 218	COMPRESSOR	EEV48FAM	1				MC			
	T97 500 216	COMPRESSOR	EEV48FAK		1	1		MC			
8	R01 E02 410	BALL VALVE	3/8"	1	1	1					
9	R01 E03 411	BALL VALVE	3/4"	1	1	1					
10	R01 38A 440	ACCUMULATOR		1	1	1					
11	R01 42L 450	STRAINER		1	1	1					
12	R01 28W 413	CHARGE PLUG		2	2	2					
13	T7W E02 242	4-WAY VALVE (COIL)		1	1	1		21S4			
14	R01 E06 403	4-WAY VALVE		1	1	1					
15	R01 KP1 467	MUFFLER		1	1	1					
16	T7W E37 202	THERMISTOR (LOW PRESSURE SATURATED TEMPERATURE DETECTION)		1				TH2			
	R01 E29 202	THERMISTOR (LOW PRESSURE SATURATED TEMPERATURE DETECTION)			1	1		TH2			
17	T7W E13 425	CAPILLARY TUBE 2	$\phi 2.5 \times \phi 0.6 \times 500\text{mm}$	1	1	1					
18	R01 38A 425	CAPILLARY TUBE 3	$\phi 4.0 \times \phi 3.0 \times 200\text{mm}$	2	2	2					
19	R01 E10 425	CAPILLARY TUBE 4	$\phi 4.0 \times \phi 2.4 \times 360\text{mm}$	1	1	1					
20	R01 E02 428	SOLENOID VALVE (COIL)		1	1	1					
21	T7W E00 242	SOLENOID COIL		1	1	1		SV1			
22	R01 37A 490	OIL SEPARATOR		1	1	1					
23	R01 05A 401	EXPANSION VALVE		1				LEV(A)			
	R01 V39 401	EXPANSION VALVE			1	1		SLEV			
24	T7W E36 202	THERMISTOR (OUTDOOR TEMPERATURE DETECTION)		1				TH6			
	R01 E31 202	THERMISTOR (OUTDOOR TEMPERATURE DETECTION)			1	1		TH6			
25	R01 E23 408	HEAT EXCHANGER		2	2	2					
26	T7W E19 763	FAN MOTOR	PA6V60-GD	1	1	1		MF2			
27	T7W E18 763	FAN MOTOR	PA6V60-GC	1	1	1		MF1			
28	R01 E00 405	DRYER		1	1	1					

STRUCTURAL PARTS
PUMY-P125VMA
PUMY-P125VMA₁
PUMY-P125YMA
PUMY-P125YMA₁

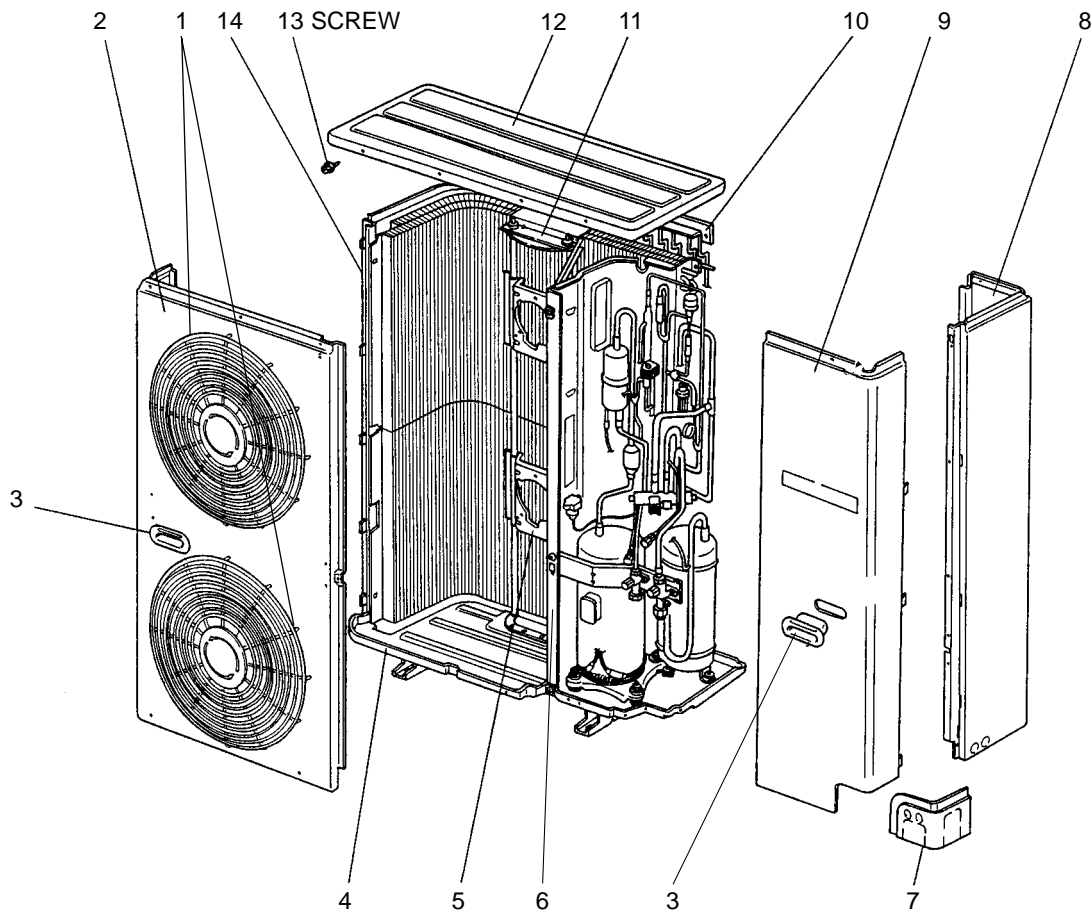

No.	Part No.	Part Name	Specification	Q'ty/set			Remarks (Drawing No.)	Wiring Diagram Symbol	Recom- mended Q'ty	Price	
				PUMY-P125						Unit	Amount
				VMA VMA ₁	YMA	YMA ₁					
1	R01 KN4 675	FAN GUARD		2	2	2					
2	R01 38A 668	FRONT PANEL		1	1	1					
3	R01 KL5 655	PANEL HANDLE		3	3	3					
4	R01 38A 686	BASE		1	1	1					
5	R01 E01 130	MOTOR SUPPORT		1	1	1					
6	—	SEPARATOR ASSY		1	1	1	(BG00G362G27)				
7	T7W E06 658	PANEL COVER		1	1	1					
8	R01 38A 682	REAR PANEL		1	1	1					
9	R01 38A 661	SERVICE PANEL		1	1	1					
10	R01 KP2 698	REAR GUARD		1	1	1					
11	—	MOTOR PLATE		1	1	1	(BG00C965G20)				
12	T7W E00 641	TOP PANEL		1							
	R01 38A 641	TOP PANEL			1	1					
13	—	SCREW (5×10)		11	11	11	(DG12F536H10)				
14	R01 KP2 662	SIDE PANEL LEFT		1	1	1					

