

Air Conditioning

Product Information

PUMY-P140VKM2
Heat Pump Outdoor Unit

Making a
World of
Difference

CITY MULTI



The PUMY City Multi model allows up to 9 indoor units to be connected to a single outdoor unit, using the standard branch pipework system proven in the larger models. Utilising the latest Mitsubishi Electric inverter technology, the system is fully controllable with all City Multi controllers or linked to third party BEMS.

Key Features

- Improved seasonal efficiency through new HIC circuit, increased heat exchanger surface area and improved fan shape
- Latest in inverter technology including a highly efficient DC Scroll Compressor, DC fan motor and Demand Control
- New AC pre-heating control reduces standby power input
- The condensing unit is extremely slimline which allows easy location and application of the system
- Anti-Corrosion blue and flat fin technology
- Connect stylish M Series wall mounted and floor mounted indoor units to the system via the LEV kit interface (PAC-LV11)
- Connect M Series and Mr Slim indoor units via the PAC-MK-BC boxes alongside VRF indoor units to the same system to provide a multi-split solution



Air Conditioning | Heating
Ventilation | Controls

Air Conditioning

Product Information

PUMY-P140VKM2 Heat Pump Outdoor Unit

Making a
World of
Difference

PUMY - OUTDOOR UNIT		PUMY-P140VKM2
CAPACITY (kW)	Heating (nominal)	18.0
	Cooling (nominal)	15.5
	Heating (UK)	14.9
	Cooling (UK)	14.3
POWER INPUT (kW)	Heating (nominal)	4.47
	Cooling (nominal)	4.52
	Heating (UK)	3.98
	Cooling (UK)	3.03
COP / EER (nominal)		4.03 / 3.43
SCOP / SEER (system)		3.61 / 5.60
Max no. OF CONNECTABLE INDOOR UNITS		12
MAX CONNECTABLE CAPACITY		50-130% OU Capacity
AIRFLOW (m ³ /min)		110
PIPE SIZE mm (in)	Gas	15.88 (5/8")
	Liquid	9.52 (3/8")
SOUND PRESSURE LEVEL (dBA)		51
WEIGHT (kg)		123
DIMENSIONS (mm)	Width	1050
	Depth	330+30
	Height	1338
ELECTRICAL SUPPLY		220-240v, 50Hz
PHASE		Single
STARTING CURRENT (A)		5
NOMINAL SYSTEM RUNNING CURRENT (A)*		19.73 / 19.95 [29.5]
Heating / Cooling [MAX]		
GUARANTEED OPERATING RANGE (°C) Heating / Cooling		-20~-15 / -5~-46
FUSE RATING (BS88) - HRC (A)		1 x 32
MAINS CABLE No. Cores		3

DIMENSIONS

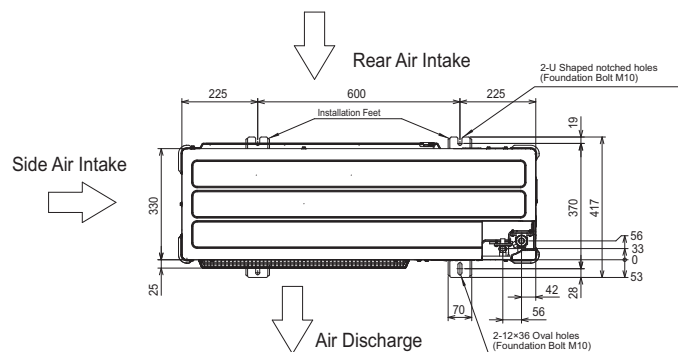
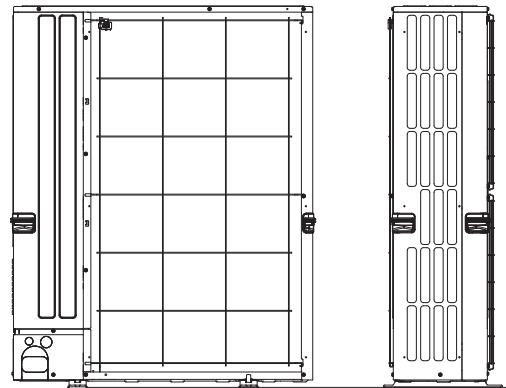
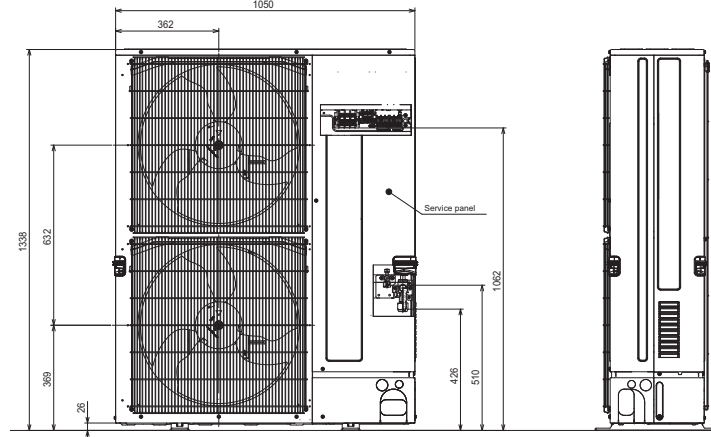

Telephone: 01707 282880

email: air.conditioning@meuk.mee.com web: www.airconditioning.mitsubishielectric.co.uk

UNITED KINGDOM Mitsubishi Electric Europe Living Environmental Systems Division
Travellers Lane, Hatfield, Hertfordshire, AL10 8XB, England General Enquiries Telephone: 01707 282880 Fax: 01707 278881
IRELAND Mitsubishi Electric Europe Westgate Business Park, Ballymount, Dublin 24, Ireland
Telephone: Dublin (01) 419 8800 Fax: Dublin (01) 419 8890 International code: (003531)

Country of origin: United Kingdom - Japan - Thailand - Malaysia. ©Mitsubishi Electric Europe 2015. Mitsubishi and Mitsubishi Electric are trademarks of Mitsubishi Electric Europe B.V. The company reserves the right to make any variation in technical specification to the equipment described, or to withdraw or replace products without prior notification or public announcement. Mitsubishi Electric is constantly developing and improving its products. All descriptions, illustrations, drawings and specifications in this publication present only general particulars and shall not form part of any contract. All goods are supplied subject to the Company's General Conditions of Sale, a copy of which is available on request. Third-party product and brand names may be trademarks or registered trademarks of their respective owners.



Note: The fuse rating is for guidance only. Please refer to the relevant databook for detailed specification. It is the responsibility of a qualified electrician/electrical engineer to select the correct cable size and fuse rating based on current regulation and site specific conditions. Mitsubishi Electric's air conditioning and heat pump systems contain fluorinated greenhouse gases R410A, R407C and R134a.



www.greengateway.mitsubishielectric.co.uk

Mitsubishi Electric UK's commitment
to the environment

Follow us @meuk_les
Follow us @green_gateway

Mitsubishi Electric
Living Environmental Systems UK

mitsubishielectric2

Effective as of April 2015