



Changes for the Better

AIR CONDITIONERS

MODEL

PUHY-RP-Y(S)JM-B
PURY-RP-YJM-B

DATA BOOK

REPLACE MULTI

1.OUTDOOR UNIT

Y SERIES 1
R2 SERIES..... 61

2.CAPACITY TABLES (Indoor unit)..... 87

3.SYSTEM DESIGN

Y SERIES 189
R2 SERIES..... 241

4.CONTROLLER..... 285

OUTDOOR UNITS

1. SPECIFICATIONS	2
2. EXTERNAL DIMENSIONS	15
3. CENTER OF GRAVITY	19
4. ELECTRICAL WIRING DIAGRAMS	20
5. SOUND LEVELS	21
6. CAPACITY TABLES	25
6-1. Correction by temperature	25
6-2. Correction by total indoor	39
6-3. Correction by refrigerant piping length	43
6-4. Correction at frost and defrost	46
6-5. Operation temperature range	47
7. OPTIONAL PARTS	48
7-1. OUTDOOR TWINNING KIT	48
8. UNIT SELECTION	49
8-1. Indoor and outdoor unit selection	49
8-2. Calculation samples	51
8-3. Pipe diameter correction factor	54

1. SPECIFICATIONS

Model		PUHY-RP200YJM-B(-BS)		PUHY-RP250YJM-B(-BS)		
Power source		3-phase 4-wire 380-400-415V 50/60Hz		3-phase 4-wire 380-400-415V 50/60Hz		
Cooling capacity (Nominal)	*1 kW	22.4		28.0		
	*1 kcal / h	19,300		24,100		
	*1 BTU / h	76,400		95,500		
	Power input	kW	5.68		7.62	
	Current input	A	9.5-9.1-8.7		12.8-12.2-11.7	
	COP	kW / kW	3.94		3.67	
Temp. range of cooling	Indoor	W.B.	15.0~24.0°C(59~75°F)		15.0~24.0°C(59~75°F)	
	Outdoor	D.B.	-5.0~43.0°C(23~109°F)		-5.0~43.0°C(23~109°F)	
Heating capacity (Nominal)	*2 kW	25.0		31.5		
	*2 kcal / h	21,500		27,100		
	*2 BTU / h	85,300		107,500		
	Power input	kW	5.69		7.22	
	Current input	A	9.6-9.1-8.7		12.1-11.5-11.1	
	COP	kW / kW	4.39		4.36	
Temp. range of heating	Indoor	D.B.	15.0~27.0°C(59~81°F)		15.0~27.0°C(59~81°F)	
	Outdoor	W.B.	-20.0~15.5°C(-4~60°F)		-20.0~15.5°C(-4~60°F)	
Indoor unit connectable	Total capacity	50~130 % of outdoor unit capacity		50~130 % of outdoor unit capacity		
	Model / Quantity	P15~P250 / 1~17		P15~P250 / 1~21		
Sound pressure level (measured in anechoic room)		dB <A>	56		57	
Refrigerant piping diameter	Liquid pipe	mm (in.)	12.7(1/2) Brazed		12.7(1/2) Brazed	
	Gas pipe	mm (in.)	28.58(1-1/8) Brazed		28.58(1-1/8) Brazed	
FAN	Type x Quantity		Propeller fan x 1		Propeller fan x 1	
	Air flow rate	m ³ / min	185		185	
		L/s	3,083		3,083	
		cfm	6,532		6,532	
	Control, Driving mechanism		Inverter-control, Direct-driven by motor		Inverter-control, Direct-driven by motor	
	Motor output	kW	0.92 x 1		0.92 x 1	
*3 External static press.		0 Pa (0 mmH ₂ O)		0 Pa (0 mmH ₂ O)		
Compressor	Type x Quantity		Inverter scroll hermetic compressor		Inverter scroll hermetic compressor	
	Manufacture		AC&R Works, MITSUBISHI ELECTRIC CORPORATION		AC&R Works, MITSUBISHI ELECTRIC CORPORATION	
	Starting method		Inverter		Inverter	
	Motor output	kW	4.8		6.8	
	Case heater	kW	0.035(240 V)		0.045(240 V)	
	Lubricant		MEL32		MEL32	
External finish		Pre-coated galvanized steel sheets (+powder coating for -BS type) <MUNSELL 5Y 8/1 or similar>		Pre-coated galvanized steel sheets (+powder coating for -BS type) <MUNSELL 5Y 8/1 or similar>		
External dimension HxWxD		mm	1,710(1,650 without legs) x 920 x 760		1,710(1,650 without legs) x 920 x 760	
		in.	67-3/8(65 without legs) x 36-1/4 x 29-15/16		67-3/8(65 without legs) x 36-1/4 x 29-15/16	
Protection devices	High pressure protection		High pressure sensor, High pressure switch at 4.15,3.3MPa (601,479 psi)		High pressure sensor, High pressure switch at 4.15,3.3MPa (601,479 psi)	
	Inverter circuit (COMP. / FAN)		Over-heat protection, Over-current protection		Over-heat protection, Over-current protection	
	Compressor		Over-heat protection		Over-heat protection	
	Fan motor		Thermal switch		Thermal switch	
Refrigerant	Type x original charge		R410A x 6.5kg (15lbs)		R410A x 9.0kg (20lbs)	
	Control		LEV and HIC circuit		LEV and HIC circuit	
Net weight		kg (lbs)	230(508)		255(563)	
Heat exchanger		Salt-resistant cross fin & copper tube		Salt-resistant cross fin & copper tube		
HIC circuit (HIC: Heat Inter-Changer)		Copper pipe,tube-in-tube structure		Copper pipe,tube-in-tube structure		
Defrosting method		Auto-defrost mode (Reversed refrigerant cycle)		Auto-defrost mode (Reversed refrigerant cycle)		
Drawing	External	KD94G725		KD94G725		
	Wiring	KE94C490		KE94C490		
Standard attachment	Document	Installation Manual		Installation Manual		
	Accessory	Refrigerant conn. pipe		Refrigerant conn. pipe		
Optional parts		Header: CMY-Y104/108/1010-G		Header: CMY-Y104/108/1010-G		
Remarks		<ul style="list-style-type: none"> •Details on foundation work, duct work, insulation work, electrical wiring, power source switch, and other items shall be referred to the Installation Manual. •Due to continuing improvement, above specifications may be subject to change without notice. •Our company is unable to guarantee reliability of pre-existing pipes and pre-existing cables. 				

Notes :

- Nominal cooling conditions (subject to JIS B8615-1)
Indoor: 27°CDB/19°CWB (81°FDB/66°FWB), Outdoor: 35°CDB (95°FDB)
Pipe length: 7.5 m (24-9/16 ft.), Level difference: 0 m (0 ft.)
- Nominal heating conditions (subject to JIS B8615-1)
Indoor: 20°CDB (68°FDB), Outdoor: 7°CDB/6°CWB (45°FDB/43°FWB)
Pipe length: 7.5 m (24-9/16 ft.), Level difference: 0 m (0 ft.)
- External static pressure option is available (30 Pa, 60 Pa/3.1 mmH₂O, 6.1 mmH₂O).

Unit converter

kcal	=kW x 860
BTU/h	=kW x 3,412
cfm	=m ³ /min x 35.31
lbs	=kg / 0.4536

*The specification data is subject to rounding variation.

1. SPECIFICATIONS

Model		PUHY-RP300YJM-B(-BS)		PUHY-RP350YJM-B(-BS)		
Power source		3-phase 4-wire 380-400-415V 50/60Hz		3-phase 4-wire 380-400-415V 50/60Hz		
Cooling capacity (Nominal)	*1	kW	33.5	40.0		
	*1	kcal / h	28,800	34,400		
	*1	BTU / h	114,300	136,500		
		Power input	kW	8.98	11.79	
		Current input	A	15.1-14.4-13.8	19.9-18.9-18.2	
		COP	kW / kW	3.73	3.39	
Temp. range of cooling	Indoor	W.B.	15.0~24.0°C(59~75°F)	15.0~24.0°C(59~75°F)		
	Outdoor	D.B.	-5.0~43.0°C(23~109°F)	-5.0~43.0°C(23~109°F)		
Heating capacity (Nominal)	*2	kW	37.5	45.0		
	*2	kcal / h	32,300	38,700		
	*2	BTU / h	128,000	153,500		
		Power input	kW	9.42	12.60	
		Current input	A	15.9-15.1-14.5	21.2-20.2-19.4	
		COP	kW / kW	3.98	3.57	
Temp. range of heating	Indoor	D.B.	15.0~27.0°C(59~81°F)	15.0~27.0°C(59~81°F)		
	Outdoor	W.B.	-20.0~15.5°C(-4~60°F)	-20.0~15.5°C(-4~60°F)		
Indoor unit connectable	Total capacity	50~130 % of outdoor unit capacity		50~130 % of outdoor unit capacity		
	Model / Quantity	P15~P250 / 1~26		P15~P250 / 1~30		
Sound pressure level (measured in anechoic room)		dB <A>	59	60		
Refrigerant piping diameter	Liquid pipe	mm (in.)	12.7(1/2) Brazed	15.88(5/8) Brazed		
	Gas pipe	mm (in.)	28.58(1-1/8) Brazed	34.93(1-3/8) Brazed		
FAN	Type x Quantity		Propeller fan x 1		Propeller fan x 1	
	Air flow rate	m ³ / min	185	185		
		L/s	3,083	3,083		
		cfm	6,532	6,532		
	Control, Driving mechanism		Inverter-control, Direct-driven by motor		Inverter-control, Direct-driven by motor	
	Motor output	kW	0.92 x 1	0.92 x 1		
*3	External static press.	0 Pa (0 mmH ₂ O)		0 Pa (0 mmH ₂ O)		
Compressor	Type x Quantity		Inverter scroll hermetic compressor		Inverter scroll hermetic compressor	
	Manufacture		AC&R Works, MITSUBISHI ELECTRIC CORPORATION		AC&R Works, MITSUBISHI ELECTRIC CORPORATION	
	Starting method		Inverter		Inverter	
	Motor output	kW	8.2	9.9		
	Case heater	kW	0.045(240 V)	0.045(240 V)		
	Lubricant		MEL32		MEL32	
External finish		Pre-coated galvanized steel sheets (+powder coating for -BS type) <MUNSELL 5Y 8/1 or similar>		Pre-coated galvanized steel sheets (+powder coating for -BS type) <MUNSELL 5Y 8/1 or similar>		
External dimension HxWxD		mm	1,710(1,650 without legs) x 920 x 760	1,710(1,650 without legs) x 920 x 760		
		in.	67-3/8(65 without legs) x 36-1/4 x 29-15/16	67-3/8(65 without legs) x 36-1/4 x 29-15/16		
Protection devices	High pressure protection		High pressure sensor, High pressure switch at 4.15,3.3MPa (601,479 psi)		High pressure sensor, High pressure switch at 4.15,3.3MPa (601,479 psi)	
	Inverter circuit (COMP. / FAN)		Over-heat protection, Over-current protection		Over-heat protection, Over-current protection	
	Compressor		Over-heat protection		Over-heat protection	
	Fan motor		Thermal switch		Thermal switch	
Refrigerant	Type x original charge		R410A x 9.0kg (20lbs)		R410A x 9.0kg (20lbs)	
	Control		LEV and HIC circuit		LEV and HIC circuit	
Net weight		kg (lbs)	255(563)	255(563)		
Heat exchanger		Salt-resistant cross fin & copper tube		Salt-resistant cross fin & copper tube		
HIC circuit (HIC: Heat Inter-Changer)		Copper pipe,tube-in-tube structure		Copper pipe,tube-in-tube structure		
Defrosting method		Auto-defrost mode (Reversed refrigerant cycle)		Auto-defrost mode (Reversed refrigerant cycle)		
Drawing	External	KD94G725		KD94G725		
	Wiring	KE94C490		KE94C490		
Standard attachment	Document	Installation Manual		Installation Manual		
	Accessory	Refrigerant conn. pipe		Refrigerant conn. pipe		
Optional parts		Header: CMY-Y104/108/1010-G		Header: CMY-Y104/108/1010-G		
Remarks		<ul style="list-style-type: none"> •Details on foundation work, duct work, insulation work, electrical wiring, power source switch, and other items shall be referred to the Installation Manual. •Due to continuing improvement, above specifications may be subject to change without notice. •Our company is unable to guarantee reliability of pre-existing pipes and pre-existing cables. 				

Notes :	Unit converter
1.Nominal cooling conditions (subject to JIS B8615-1) Indoor: 27°CDB/19°CWB (81°FDB/66°FWB), Outdoor: 35°CDB (95°FDB) Pipe length: 7.5 m (24-9/16 ft.), Level difference: 0 m (0 ft.)	kcal =kW x 860 BTU/h =kW x 3,412
2.Nominal heating conditions (subject to JIS B8615-1) Indoor: 20°CDB (68°FDB), Outdoor: 7°CDB/6°CWB (45°FDB/43°FWB) Pipe length: 7.5 m (24-9/16 ft.), Level difference: 0 m (0 ft.)	cfm =m ³ /min x 35.31 lbs =kg / 0.4536
3.External static pressure option is available (30 Pa, 60 Pa/3.1 mmH ₂ O, 6.1 mmH ₂ O).	
	*The specification data is subject to rounding variation.

1. SPECIFICATIONS

Model			PUHY-RP400YSJM-B(-BS)		
Power source			3-phase 4-wire 380-400-415V 50/60Hz		
Cooling capacity (Nominal)	*1	kW	45.0		
	*1	kcal / h	38,700		
	*1	BTU / h	153,500		
	Power input		kW	11.87	
	Current input		A	20.0-19.0-18.3	
COP		kW / kW	3.79		
Temp. range of cooling	Indoor	W.B.	15.0~24.0°C(59~75°F)		
	Outdoor	D.B.	-5.0~43.0°C(23~109°F)		
Heating capacity (Nominal)	*2	kW	50.0		
	*2	kcal / h	43,000		
	*2	BTU / h	170,600		
	Power input		kW	11.38	
	Current input		A	19.2-18.2-17.5	
COP		kW / kW	4.39		
Temp. range of heating	Indoor	D.B.	15.0~27.0°C(59~81°F)		
	Outdoor	W.B.	-20.0~15.5°C(-4~60°F)		
Indoor unit connectable	Total capacity		50~130 % of outdoor unit capacity		
	Model / Quantity		P15~P250 / 1~32		
Sound pressure level (measured in anechoic room)			dB <A>		
			59		
Refrigerant	Liquid pipe	mm (in.)	15.88(5/8) Brazed		
piping diameter	Gas pipe	mm (in.)	34.93(1-3/8) Brazed		

Set Model

Model			PUHY-RP200YJM-B(-BS)		PUHY-RP200YJM-B(-BS)	
FAN	Type x Quantity		Propeller fan x 1		Propeller fan x 1	
	Air flow rate	m ³ / min	185		185	
		L/s	3,083		3,083	
		cfm	6,532		6,532	
	Control , Driving mechanism		Inverter-control, Direct-driven by motor		Inverter-control, Direct-driven by motor	
	Motor output	kW	0.92 x 1		0.92 x 1	
*3	External static press.		0 Pa (0 mmH ₂ O)		0 Pa (0 mmH ₂ O)	
Compressor	Type x Quantity		Inverter scroll hermetic compressor		Inverter scroll hermetic compressor	
	Manufacture		AC&R Works, MITSUBISHI ELECTRIC CORPORATION		AC&R Works, MITSUBISHI ELECTRIC CORPORATION	
	Starting method		Inverter		Inverter	
	Motor output	kW	4.8		4.8	
	Case heater	kW	0.035(240 V)		0.035(240 V)	
Lubricant		MEL32		MEL32		
External finish			Pre-coated galvanized steel sheets (+powder coating for -BS type) <MUNSELL 5Y 8/1 or similar>		Pre-coated galvanized steel sheets (+powder coating for -BS type) <MUNSELL 5Y 8/1 or similar>	
External dimension HxWxD		mm	1,710(1,650 without legs) x 920 x 760		1,710(1,650 without legs) x 920 x 760	
		in.	67-3/8(65 without legs) x 36-1/4 x 29-15/16		67-3/8(65 without legs) x 36-1/4 x 29-15/16	
Protection devices	High pressure protection		High pressure sensor, High pressure switch at 4.15,3.3MPa (601,479 psi)		High pressure sensor, High pressure switch at 4.15,3.3MPa (601,479 psi)	
	Inverter circuit (COMP. / FAN)		Over-heat protection, Over-current protection		Over-heat protection, Over-current protection	
	Compressor		Over-heat protection		Over-heat protection	
	Fan motor		Thermal switch		Thermal switch	
Refrigerant	Type x original charge		R410A x 6.5kg (15lbs)		R410A x 6.5kg (15lbs)	
	Control		LEV and HIC circuit			
Net weight		kg (lbs)	230(508)		230(508)	
Heat exchanger			Salt-resistant cross fin & copper tube		Salt-resistant cross fin & copper tube	
HIC circuit (HIC: Heat Inter-Changer)			Copper pipe,tube-in-tube structure		Copper pipe,tube-in-tube structure	
Pipe between unit and distributor	Liquid pipe	mm (in.)	9.52(3/8) Brazed		9.52(3/8) Brazed	
	Gas pipe	mm (in.)	19.05(3/4) Brazed		19.05(3/4) Brazed	
Defrosting method			Auto-defrost mode (Reversed refrigerant cycle)			
Drawing	External		KD94G726			
	Wiring		KE94C490		KE94C490	
Standard attachment	Document		Installation Manual			
	Accessory		Refrigerant conn. pipe			
Optional parts			Outdoor Twinning kit: CMY-RP100VBK Header: CMY-Y104/108/1010-G			
Remarks			<ul style="list-style-type: none"> •Details on foundation work, duct work, insulation work, electrical wiring, power source switch, and other items shall be referred to the Installation Manual. •Due to continuing improvement, above specifications may be subject to change without notice. •Our company is unable to guarantee reliability of pre-existing pipes and pre-existing cables. 			

Notes :

- Nominal cooling conditions (subject to JIS B8615-1)
Indoor: 27°CDB/19°CWB (81°FDB/66°FWB), Outdoor: 35°CDB (95°FDB)
Pipe length: 7.5 m (24-9/16 ft.), Level difference: 0 m (0 ft.)
- Nominal heating conditions (subject to JIS B8615-1)
Indoor: 20°CDB (68°FDB), Outdoor: 7°CDB/6°CWB (45°FDB/43°FWB)
Pipe length: 7.5 m (24-9/16 ft.), Level difference: 0 m (0 ft.)
- External static pressure option is available (30 Pa, 60 Pa/3.1 mmH₂O, 6.1 mmH₂O).

Unit converter

kcal	=kW x 860
BTU/h	=kW x 3,412
cfm	=m ³ /min x 35.31
lbs	=kg / 0.4536

*The specification data is subject to rounding variation.

1. SPECIFICATIONS

Model			PUHY-RP450YSJM-B(-BS)	
Power source			3-phase 4-wire 380-400-415V 50/60Hz	
Cooling capacity (Nominal)	*1	kW	50.0	
	*1	kcal / h	43,000	
	*1	BTU / h	170,600	
	Power input	kW	13.77	
	Current input	A	23.2-22.0-21.2	
Temp. range of cooling	COP	kW / kW	3.63	
	Indoor	W.B.	15.0~24.0°C(59~75°F)	
	Outdoor	D.B.	-5.0~43.0°C(23~109°F)	
Heating capacity (Nominal)	*2	kW	56.0	
	*2	kcal / h	48,200	
	*2	BTU / h	191,100	
	Power input	kW	12.81	
	Current input	A	21.6-20.5-19.8	
Temp. range of heating	COP	kW / kW	4.37	
	Indoor	D.B.	15.0~27.0°C(59~81°F)	
Outdoor	W.B.	-20.0~15.5°C(-4~60°F)		
Indoor unit connectable	Total capacity	50~130 % of outdoor unit capacity		
	Model / Quantity	P15~P250 / 1~32		
Sound pressure level (measured in anechoic room)		dB <A>	59.5	
Refrigerant piping diameter	Liquid pipe	mm (in.)	15.88(5/8) Brazed	
	Gas pipe	mm (in.)	34.93(1-3/8) Brazed	

Set Model

Model			PUHY-RP200YJM-B(-BS)		PUHY-RP250YJM-B(-BS)	
FAN	Type x Quantity		Propeller fan x 1		Propeller fan x 1	
	Air flow rate	m ³ / min	185		185	
		L/s	3,083		3,083	
		cfm	6,532		6,532	
	Control, Driving mechanism		Inverter-control, Direct-driven by motor		Inverter-control, Direct-driven by motor	
	Motor output	kW	0.92 x 1		0.92 x 1	
*3 External static press.		0 Pa (0 mmH ₂ O)		0 Pa (0 mmH ₂ O)		
Compressor	Type x Quantity		Inverter scroll hermetic compressor		Inverter scroll hermetic compressor	
	Manufacture		AC&R Works, MITSUBISHI ELECTRIC CORPORATION		AC&R Works, MITSUBISHI ELECTRIC CORPORATION	
	Starting method		Inverter		Inverter	
	Motor output	kW	4.8		6.8	
	Case heater	kW	0.035(240 V)		0.045(240 V)	
	Lubricant		MEL32		MEL32	
External finish			Pre-coated galvanized steel sheets (+powder coating for -BS type) <MUNSELL 5Y 8/1 or similar>		Pre-coated galvanized steel sheets (+powder coating for -BS type) <MUNSELL 5Y 8/1 or similar>	
External dimension HxWxD			1,710(1,650 without legs) x 920 x 760 67-3/8(65 without legs) x 36-1/4 x 29-15/16		1,710(1,650 without legs) x 920 x 760 67-3/8(65 without legs) x 36-1/4 x 29-15/16	
Protection devices	High pressure protection		High pressure sensor, High pressure switch at 4.15,3.3MPa (601,479 psi)		High pressure sensor, High pressure switch at 4.15,3.3MPa (601,479 psi)	
	Inverter circuit (COMP. / FAN)		Over-heat protection, Over-current protection		Over-heat protection, Over-current protection	
	Compressor		Over-heat protection		Over-heat protection	
	Fan motor		Thermal switch		Thermal switch	
Refrigerant	Type x original charge		R410A x 6.5kg (15lbs)		R410A x 9.0kg (20lbs)	
	Control		LEV and HIC circuit			
Net weight	kg (lbs)	230(508)		255(563)		
Heat exchanger			Salt-resistant cross fin & copper tube		Salt-resistant cross fin & copper tube	
HIC circuit (HIC: Heat Inter-Changer)			Copper pipe,tube-in-tube structure		Copper pipe,tube-in-tube structure	
Pipe between unit and distributor	Liquid pipe	mm (in.)	9.52(3/8) Brazed		9.52(3/8) Brazed	
	Gas pipe	mm (in.)	19.05(3/4) Brazed		22.2(7/8) Brazed	
Defrosting method			Auto-defrost mode (Reversed refrigerant cycle)			
Drawing	External		KD94G726			
	Wiring		KE94C490		KE94C490	
Standard attachment	Document		Installation Manual			
	Accessory		Refrigerant conn. pipe			
Optional parts			Outdoor Twinning kit: CMY-RP100VBK Header: CMY-Y104/108/1010-G			
Remarks			<ul style="list-style-type: none"> •Details on foundation work, duct work, insulation work, electrical wiring, power source switch, and other items shall be referred to the Installation Manual. •Due to continuing improvement, above specifications may be subject to change without notice. •Our company is unable to guarantee reliability of pre-existing pipes and pre-existing cables. 			

Notes :

- Nominal cooling conditions (subject to JIS B8615-1)
Indoor: 27°CDB/19°CWB (81°FDB/66°FWB), Outdoor: 35°CDB (95°FDB)
Pipe length: 7.5 m (24-9/16 ft.), Level difference: 0 m (0 ft.)
- Nominal heating conditions (subject to JIS B8615-1)
Indoor: 20°CDB (68°FDB), Outdoor: 7°CDB/6°CWB (45°FDB/43°FWB)
Pipe length: 7.5 m (24-9/16 ft.), Level difference: 0 m (0 ft.)
- External static pressure option is available (30 Pa, 60 Pa/3.1 mmH₂O, 6.1 mmH₂O).

Unit converter

kcal	=kW x 860
BTU/h	=kW x 3,412
cfm	=m ³ /min x 35.31
lbs	=kg / 0.4536

*The specification data is subject to rounding variation.

1. SPECIFICATIONS

Model			PUHY-RP500YSJM-B(-BS)		
Power source			3-phase 4-wire 380-400-415V 50/60Hz		
Cooling capacity (Nominal)	*1	kW	56.0		
	*1	kcal / h	48,200		
	*1	BTU / h	191,100		
		Power input	kW	15.68	
		Current input	A	26.4-25.1-24.2	
		COP	kW / kW		3.57
Temp. range of cooling	Indoor	W.B.	15.0~24.0°C(59~75°F)		
	Outdoor	D.B.	-5.0~43.0°C(23~109°F)		
Heating capacity (Nominal)	*2	kW	63.0		
	*2	kcal / h	54,200		
	*2	BTU / h	215,000		
		Power input	kW	14.44	
		Current input	A	24.3-23.1-22.3	
		COP	kW / kW		4.36
Temp. range of heating	Indoor	D.B.	15.0~27.0°C(59~81°F)		
	Outdoor	W.B.	-20.0~15.5°C(-4~60°F)		
Indoor unit connectable	Total capacity	50~130 % of outdoor unit capacity			
	Model / Quantity	P15~P250 / 1~32			
Sound pressure level (measured in anechoic room)			dB <A>	60	
Refrigerant piping diameter	Liquid pipe	mm (in.)	15.88(5/8) Brazed		
	Gas pipe	mm (in.)	34.93(1-3/8) Brazed		

Set Model			PUHY-RP250YJM-B(-BS)		PUHY-RP250YJM-B(-BS)	
FAN	Type x Quantity		Propeller fan x 1		Propeller fan x 1	
	Air flow rate	m ³ / min	185		185	
		L/s	3,083		3,083	
		cfm	6,532		6,532	
	Control , Driving mechanism		Inverter-control, Direct-driven by motor		Inverter-control, Direct-driven by motor	
	Motor output	kW	0.92 x 1		0.92 x 1	
*3 External static press.			0 Pa (0 mmH ₂ O)		0 Pa (0 mmH ₂ O)	
Compressor	Type x Quantity		Inverter scroll hermetic compressor		Inverter scroll hermetic compressor	
	Manufacture		AC&R Works, MITSUBISHI ELECTRIC CORPORATION		AC&R Works, MITSUBISHI ELECTRIC CORPORATION	
	Starting method		Inverter		Inverter	
	Motor output	kW	6.8		6.8	
	Case heater	kW	0.045(240 V)		0.045(240 V)	
Lubricant		MEL32		MEL32		
External finish			Pre-coated galvanized steel sheets (+powder coating for -BS type) <MUNSELL 5Y 8/1 or similar>		Pre-coated galvanized steel sheets (+powder coating for -BS type) <MUNSELL 5Y 8/1 or similar>	
External dimension HxWxD		mm	1,710(1,650 without legs) x 920 x 760		1,710(1,650 without legs) x 920 x 760	
		in.	67-3/8(65 without legs) x 36-1/4 x 29-15/16		67-3/8(65 without legs) x 36-1/4 x 29-15/16	
Protection devices	High pressure protection		High pressure sensor, High pressure switch at 4.15,3.3MPa (601,479 psi)		High pressure sensor, High pressure switch at 4.15,3.3MPa (601,479 psi)	
	Inverter circuit (COMP. / FAN)		Over-heat protection, Over-current protection		Over-heat protection, Over-current protection	
	Compressor		Over-heat protection		Over-heat protection	
	Fan motor		Thermal switch		Thermal switch	
Refrigerant	Type x original charge		R410A x 9.0kg (20lbs)		R410A x 9.0kg (20lbs)	
	Control		LEV and HIC circuit			
Net weight		kg (lbs)	255(563)		255(563)	
Heat exchanger			Salt-resistant cross fin & copper tube		Salt-resistant cross fin & copper tube	
HIC circuit (HIC: Heat Inter-Changer)			Copper pipe,tube-in-tube structure		Copper pipe,tube-in-tube structure	
Pipe between unit and distributor	Liquid pipe	mm (in.)	9.52(3/8) Brazed		9.52(3/8) Brazed	
	Gas pipe	mm (in.)	22.2(7/8) Brazed		22.2(7/8) Brazed	
Defrosting method			Auto-defrost mode (Reversed refrigerant cycle)			
Drawing	External		KD94G726			
	Wiring		KE94C490		KE94C490	
Standard attachment	Document		Installation Manual			
	Accessory		Refrigerant conn. pipe			
Optional parts			Outdoor Twinning kit: CMY-RP100VBK Header: CMY-Y104/108/1010-G			
Remarks			<ul style="list-style-type: none"> •Details on foundation work, duct work, insulation work, electrical wiring, power source switch, and other items shall be referred to the Installation Manual. •Due to continuing improvement, above specifications may be subject to change without notice. •Our company is unable to guarantee reliability of pre-existing pipes and pre-existing cables. 			

Notes :	Unit converter
1.Nominal cooling conditions (subject to JIS B8615-1) Indoor: 27°CDB/19°CWB (81°FDB/66°FWB), Outdoor: 35°CDB (95°FDB) Pipe length: 7.5 m (24-9/16 ft.), Level difference: 0 m (0 ft.)	kcal =kW x 860 BTU/h =kW x 3,412
2.Nominal heating conditions (subject to JIS B8615-1) Indoor: 20°CDB (68°FDB), Outdoor: 7°CDB/6°CWB (45°FDB/43°FWB) Pipe length: 7.5 m (24-9/16 ft.), Level difference: 0 m (0 ft.)	cfm =m ³ /min x 35.31 lbs =kg / 0.4536
3.External static pressure option is available (30 Pa, 60 Pa/3.1 mmH ₂ O, 6.1 mmH ₂ O).	*The specification data is subject to rounding variation.

1. SPECIFICATIONS

Model			PUHY-RP550YSJM-B(-BS)	
Power source			3-phase 4-wire 380-400-415V 50/60Hz	
Cooling capacity (Nominal)	*1	kW	63.0	
		kcal / h	54,200	
		BTU / h	215,000	
	Power input	kW	17.50	
		Current input	A	29.5-28.0-27.0
COP		kW / kW	3.60	
Temp. range of cooling	Indoor	W.B.	15.0~24.0°C(59~75°F)	
	Outdoor	D.B.	-5.0~43.0°C(23~109°F)	
Heating capacity (Nominal)	*2	kW	69.0	
		kcal / h	59,300	
		BTU / h	235,400	
	Power input	kW	16.62	
		Current input	A	28.0-26.6-25.6
COP		kW / kW	4.15	
Temp. range of heating	Indoor	D.B.	15.0~27.0°C(59~81°F)	
	Outdoor	W.B.	-20.0~15.5°C(-4~60°F)	
Indoor unit connectable	Total capacity	50~130 % of outdoor unit capacity		
	Model / Quantity	P15~P250 / 1~32		
Sound pressure level (measured in anechoic room)		dB <A>	61	
Refrigerant piping diameter	Liquid pipe	mm (in.)	15.88(5/8) Brazed	
	Gas pipe	mm (in.)	34.93(1-3/8) Brazed	

Set Model

Model			PUHY-RP250YJM-B(-BS)		PUHY-RP300YJM-B(-BS)	
FAN	Type x Quantity		Propeller fan x 1		Propeller fan x 1	
	Air flow rate	m ³ / min	185		185	
		L/s	3,083		3,083	
		cfm	6,532		6,532	
	Control, Driving mechanism		Inverter-control, Direct-driven by motor		Inverter-control, Direct-driven by motor	
	*3 External static press.	Motor output	kW	0.92 x 1		0.92 x 1
		0 Pa (0 mmH ₂ O)		0 Pa (0 mmH ₂ O)		
Compressor	Type x Quantity		Inverter scroll hermetic compressor		Inverter scroll hermetic compressor	
	Manufacture		AC&R Works, MITSUBISHI ELECTRIC CORPORATION		AC&R Works, MITSUBISHI ELECTRIC CORPORATION	
	Starting method		Inverter		Inverter	
	Motor output	kW	6.8		8.2	
	Case heater	kW	0.045(240 V)		0.045(240 V)	
	Lubricant		MEL32		MEL32	
External finish			Pre-coated galvanized steel sheets (+powder coating for -BS type) <MUNSELL 5Y 8/1 or similar>		Pre-coated galvanized steel sheets (+powder coating for -BS type) <MUNSELL 5Y 8/1 or similar>	
External dimension HxWxD			mm 1,710(1,650 without legs) x 920 x 760 67-3/8(65 without legs) x 36-1/4 x 29-15/16		mm 1,710(1,650 without legs) x 920 x 760 67-3/8(65 without legs) x 36-1/4 x 29-15/16	
Protection devices	High pressure protection		High pressure sensor, High pressure switch at 4.15,3.3MPa (601,479 psi)		High pressure sensor, High pressure switch at 4.15,3.3MPa (601,479 psi)	
	Inverter circuit (COMP. / FAN)		Over-heat protection, Over-current protection		Over-heat protection, Over-current protection	
	Compressor		Over-heat protection		Over-heat protection	
	Fan motor		Thermal switch		Thermal switch	
Refrigerant	Type x original charge		R410A x 9.0kg (20lbs)		R410A x 9.0kg (20lbs)	
	Control		LEV and HIC circuit			
Net weight	kg (lbs)	255(563)		255(563)		
Heat exchanger			Salt-resistant cross fin & copper tube		Salt-resistant cross fin & copper tube	
HIC circuit (HIC: Heat Inter-Changer)			Copper pipe,tube-in-tube structure		Copper pipe,tube-in-tube structure	
Pipe between unit and distributor	Liquid pipe	mm (in.)	9.52(3/8) Brazed		12.7(1/2) Brazed	
	Gas pipe	mm (in.)	22.2(7/8) Brazed		22.2(7/8) Brazed	
Defrosting method			Auto-defrost mode (Reversed refrigerant cycle)			
Drawing	External		KD94G726			
	Wiring		KE94C490		KE94C490	
Standard attachment	Document		Installation Manual			
	Accessory		Refrigerant conn. pipe			
Optional parts			Outdoor Twinning kit: CMY-RP100VBK Header: CMY-Y104/108/1010-G			
Remarks			<ul style="list-style-type: none"> •Details on foundation work, duct work, insulation work, electrical wiring, power source switch, and other items shall be referred to the Installation Manual. •Due to continuing improvement, above specifications may be subject to change without notice. •Our company is unable to guarantee reliability of pre-existing pipes and pre-existing cables. 			

Notes :

- Nominal cooling conditions (subject to JIS B8615-1)
Indoor: 27°CDB/19°CWB (81°FDB/66°FWB), Outdoor: 35°CDB (95°FDB)
Pipe length: 7.5 m (24-9/16 ft.), Level difference: 0 m (0 ft.)
- Nominal heating conditions (subject to JIS B8615-1)
Indoor: 20°CDB (68°FDB), Outdoor: 7°CDB/6°CWB (45°FDB/43°FWB)
Pipe length: 7.5 m (24-9/16 ft.), Level difference: 0 m (0 ft.)
- External static pressure option is available (30 Pa, 60 Pa/3.1 mmH₂O, 6.1 mmH₂O).

Unit converter

kcal	=kW x 860
BTU/h	=kW x 3,412
cfm	=m ³ /min x 35.31
lbs	=kg / 0.4536

*The specification data is subject to rounding variation.

1. SPECIFICATIONS

Model			PUHY-RP600YSJM-B(-BS)		
Power source			3-phase 4-wire 380-400-415V 50/60Hz		
Cooling capacity (Nominal)	*1	kW	69.0		
	*1	kcal / h	59,300		
	*1	BTU / h	235,400		
		Power input	kW	18.59	
		Current input	A	31.3-29.8-28.7	
Temp. range of cooling		COP	3.71		
	Indoor	W.B.	15.0~24.0°C(59~75°F)		
	Outdoor	D.B.	-5.0~43.0°C(23~109°F)		
Heating capacity (Nominal)	*2	kW	76.5		
	*2	kcal / h	65,800		
	*2	BTU / h	261,000		
		Power input	kW	19.22	
		Current input	A	32.4-30.8-29.7	
Temp. range of heating		COP	3.98		
	Indoor	D.B.	15.0~27.0°C(59~81°F)		
	Outdoor	W.B.	-20.0~15.5°C(-4~60°F)		
Indoor unit connectable	Total capacity		50~130 % of outdoor unit capacity		
	Model / Quantity		P15~P250 / 1~32		
Sound pressure level (measured in anechoic room)			dB <A>		
			62		
Refrigerant piping diameter	Liquid pipe	mm (in.)	19.05(3/4) Brazed		
	Gas pipe	mm (in.)	34.93(1-3/8) Brazed		

Set Model

Model			PUHY-RP300YJM-B(-BS)		PUHY-RP300YJM-B(-BS)	
FAN	Type x Quantity		Propeller fan x 1		Propeller fan x 1	
	Air flow rate	m ³ / min	185		185	
		L/s	3,083		3,083	
		cfm	6,532		6,532	
	Control , Driving mechanism		Inverter-control, Direct-driven by motor		Inverter-control, Direct-driven by motor	
	Motor output	kW	0.92 x 1		0.92 x 1	
	*3 External static press.		0 Pa (0 mmH ₂ O)		0 Pa (0 mmH ₂ O)	
Compressor	Type x Quantity		Inverter scroll hermetic compressor		Inverter scroll hermetic compressor	
	Manufacture		AC&R Works, MITSUBISHI ELECTRIC CORPORATION		AC&R Works, MITSUBISHI ELECTRIC CORPORATION	
	Starting method		Inverter		Inverter	
	Motor output	kW	8.2		8.2	
	Case heater	kW	0.045(240 V)		0.045(240 V)	
	Lubricant		MEL32		MEL32	
External finish			Pre-coated galvanized steel sheets (+powder coating for -BS type) <MUNSELL 5Y 8/1 or similar>		Pre-coated galvanized steel sheets (+powder coating for -BS type) <MUNSELL 5Y 8/1 or similar>	
External dimension HxWxD			mm 1,710(1,650 without legs) x 920 x 760 in. 67-3/8(65 without legs) x 36-1/4 x 29-15/16		mm 1,710(1,650 without legs) x 920 x 760 in. 67-3/8(65 without legs) x 36-1/4 x 29-15/16	
Protection devices	High pressure protection		High pressure sensor, High pressure switch at 4.15,3.3MPa (601,479 psi)		High pressure sensor, High pressure switch at 4.15,3.3MPa (601,479 psi)	
	Inverter circuit (COMP. / FAN)		Over-heat protection, Over-current protection		Over-heat protection, Over-current protection	
	Compressor		Over-heat protection		Over-heat protection	
	Fan motor		Thermal switch		Thermal switch	
Refrigerant	Type x original charge		R410A x 9.0kg (20lbs)		R410A x 9.0kg (20lbs)	
	Control		LEV and HIC circuit			
Net weight			kg (lbs)		255(563)	
Heat exchanger			Salt-resistant cross fin & copper tube		Salt-resistant cross fin & copper tube	
HIC circuit (HIC: Heat Inter-Changer)			Copper pipe,tube-in-tube structure		Copper pipe,tube-in-tube structure	
Pipe between unit and distributor	Liquid pipe	mm (in.)	12.7(1/2) Brazed		12.7(1/2) Brazed	
	Gas pipe	mm (in.)	22.2(7/8) Brazed		22.2(7/8) Brazed	
Defrosting method			Auto-defrost mode (Reversed refrigerant cycle)			
Drawing	External		KD94G726			
	Wiring		KE94C490		KE94C490	
Standard attachment	Document		Installation Manual			
	Accessory		Refrigerant conn. pipe			
Optional parts			Outdoor Twinning kit: CMY-RP100VBK Header: CMY-Y104/108/1010-G			
Remarks			<ul style="list-style-type: none"> •Details on foundation work, duct work, insulation work, electrical wiring, power source switch, and other items shall be referred to the Installation Manual. •Due to continuing improvement, above specifications may be subject to change without notice. •Our company is unable to guarantee reliability of pre-existing pipes and pre-existing cables. 			

Notes :

- Nominal cooling conditions (subject to JIS B8615-1)
Indoor: 27°CDB/19°CWB (81°FDB/66°FWB), Outdoor: 35°CDB (95°FDB)
Pipe length: 7.5 m (24-9/16 ft.), Level difference: 0 m (0 ft.)
- Nominal heating conditions (subject to JIS B8615-1)
Indoor: 20°CDB (68°FDB), Outdoor: 7°CDB/6°CWB (45°FDB/43°FWB)
Pipe length: 7.5 m (24-9/16 ft.), Level difference: 0 m (0 ft.)
- External static pressure option is available (30 Pa, 60 Pa/3.1 mmH₂O, 6.1 mmH₂O).

Unit converter

kcal	=kW x 860
BTU/h	=kW x 3,412
cfm	=m ³ /min x 35.31
lbs	=kg / 0.4536

*The specification data is subject to rounding variation.

1. SPECIFICATIONS

Model			PUHY-RP650YSJM-B(-BS)	
Power source			3-phase 4-wire 380-400-415V 50/60Hz	
Cooling capacity (Nominal)	*1	kW	73.0	
		kcal / h	62,800	
		BTU / h	249,100	
	Power input	kW	21.09	
		Current input	A	35.6-33.8-32.6
COP		kW / kW	3.46	
Temp. range of cooling	Indoor	W.B.	15.0~24.0°C(59~75°F)	
	Outdoor	D.B.	-5.0~43.0°C(23~109°F)	
Heating capacity (Nominal)	*2	kW	81.5	
		kcal / h	70,100	
		BTU / h	278,100	
	Power input	kW	21.73	
		Current input	A	36.6-34.8-33.5
COP		kW / kW	3.75	
Temp. range of heating	Indoor	D.B.	15.0~27.0°C(59~81°F)	
	Outdoor	W.B.	-20.0~15.5°C(-4~60°F)	
Indoor unit connectable	Total capacity	50~130 % of outdoor unit capacity		
	Model / Quantity	P15~P250 / 1~32		
Sound pressure level (measured in anechoic room)		dB <A>	62.5	
Refrigerant piping diameter	Liquid pipe	mm (in.)	19.05(3/4) Brazed	
	Gas pipe	mm (in.)	41.28(1-5/8) Brazed	

Set Model

Model			PUHY-RP300YJM-B(-BS)		PUHY-RP350YJM-B(-BS)	
FAN	Type x Quantity		Propeller fan x 1		Propeller fan x 1	
	Air flow rate	m ³ / min	185		185	
		L/s	3,083		3,083	
		cfm	6,532		6,532	
	Control , Driving mechanism		Inverter-control, Direct-driven by motor		Inverter-control, Direct-driven by motor	
	*3	Motor output	kW	0.92 x 1		0.92 x 1
External static press.		0 Pa (0 mmH ₂ O)		0 Pa (0 mmH ₂ O)		
Compressor	Type x Quantity		Inverter scroll hermetic compressor		Inverter scroll hermetic compressor	
	Manufacture		AC&R Works, MITSUBISHI ELECTRIC CORPORATION		AC&R Works, MITSUBISHI ELECTRIC CORPORATION	
	Starting method		Inverter		Inverter	
	Motor output	kW	8.2		9.9	
	Case heater	kW	0.045(240 V)		0.045(240 V)	
	Lubricant		MEL32		MEL32	
External finish			Pre-coated galvanized steel sheets (+powder coating for -BS type) <MUNSELL 5Y 8/1 or similar>		Pre-coated galvanized steel sheets (+powder coating for -BS type) <MUNSELL 5Y 8/1 or similar>	
External dimension HxWxD			mm 1,710(1,650 without legs) x 920 x 760 67-3/8(65 without legs) x 36-1/4 x 29-15/16		mm 1,710(1,650 without legs) x 920 x 760 67-3/8(65 without legs) x 36-1/4 x 29-15/16	
Protection devices	High pressure protection		High pressure sensor, High pressure switch at 4.15,3.3MPa (601,479 psi)		High pressure sensor, High pressure switch at 4.15,3.3MPa (601,479 psi)	
	Inverter circuit (COMP. / FAN)		Over-heat protection, Over-current protection		Over-heat protection, Over-current protection	
	Compressor		Over-heat protection		Over-heat protection	
	Fan motor		Thermal switch		Thermal switch	
Refrigerant	Type x original charge		R410A x 9.0kg (20lbs)		R410A x 9.0kg (20lbs)	
	Control		LEV and HIC circuit			
Net weight	kg (lbs)	255(563)		255(563)		
Heat exchanger			Salt-resistant cross fin & copper tube		Salt-resistant cross fin & copper tube	
HIC circuit (HIC: Heat Inter-Changer)			Copper pipe,tube-in-tube structure		Copper pipe,tube-in-tube structure	
Pipe between unit and distributor	Liquid pipe	mm (in.)	12.7(1/2) Brazed		12.7(1/2) Brazed	
	Gas pipe	mm (in.)	22.2(7/8) Brazed		28.58(1-1/8) Brazed	
Defrosting method			Auto-defrost mode (Reversed refrigerant cycle)			
Drawing	External		KD94G726			
	Wiring		KE94C490		KE94C490	
Standard attachment	Document		Installation Manual			
	Accessory		Refrigerant conn. pipe			
Optional parts			Outdoor Twinning kit: CMY-RP100VBK Header: CMY-Y104/108/1010-G			
Remarks			<ul style="list-style-type: none"> •Details on foundation work, duct work, insulation work, electrical wiring, power source switch, and other items shall be referred to the Installation Manual. •Due to continuing improvement, above specifications may be subject to change without notice. •Our company is unable to guarantee reliability of pre-existing pipes and pre-existing cables. 			

Notes :

- Nominal cooling conditions (subject to JIS B8615-1)
Indoor: 27°CDB/19°CWB (81°FDB/66°FWB), Outdoor: 35°CDB (95°FDB)
Pipe length: 7.5 m (24-9/16 ft.), Level difference: 0 m (0 ft.)
- Nominal heating conditions (subject to JIS B8615-1)
Indoor: 20°CDB (68°FDB), Outdoor: 7°CDB/6°CWB (45°FDB/43°FWB)
Pipe length: 7.5 m (24-9/16 ft.), Level difference: 0 m (0 ft.)
- External static pressure option is available (30 Pa, 60 Pa/3.1 mmH₂O, 6.1 mmH₂O).

Unit converter

kcal	=kW x 860
BTU/h	=kW x 3,412
cfm	=m ³ /min x 35.31
lbs	=kg / 0.4536

*The specification data is subject to rounding variation.

1. SPECIFICATIONS

Model			PUHY-RP700YSJM-B(-BS)		
Power source			3-phase 4-wire 380-400-415V 50/60Hz		
Cooling capacity (Nominal)	*1	kW	80.0		
	*1	kcal / h	68,800		
	*1	BTU / h	273,000		
	Power input		kW	22.22	
	Current input		A	37.5-35.6-34.3	
COP		kW / kW	3.60		
Temp. range of cooling	Indoor	W.B.	15.0~24.0°C(59~75°F)		
	Outdoor	D.B.	-5.0~43.0°C(23~109°F)		
Heating capacity (Nominal)	*2	kW	88.0		
	*2	kcal / h	75,700		
	*2	BTU / h	300,300		
	Power input		kW	20.13	
	Current input		A	33.9-32.2-31.1	
COP		kW / kW	4.37		
Temp. range of heating	Indoor	D.B.	15.0~27.0°C(59~81°F)		
	Outdoor	W.B.	-20.0~15.5°C(-4~60°F)		
Indoor unit connectable	Total capacity		50~130 % of outdoor unit capacity		
	Model / Quantity		P15~P250 / 1~32		
Sound pressure level (measured in anechoic room)			dB <A>		
			61.5		
Refrigerant piping diameter	Liquid pipe		mm (in.)		
	Gas pipe		mm (in.)		
				19.05(3/4) Brazed	
				41.28(1-5/8) Brazed	

Set Model

Model			PUHY-RP200YJM-B(-BS)		PUHY-RP250YJM-B(-BS)		PUHY-RP250YJM-B(-BS)	
FAN	Type x Quantity		Propeller fan x 1		Propeller fan x 1		Propeller fan x 1	
	Air flow rate	m ³ / min	185		185		185	
		L/s	3,083		3,083		3,083	
		cfm	6,532		6,532		6,532	
	Control , Driving mechanism		Inverter-control, Direct-driven by motor		Inverter-control, Direct-driven by motor		Inverter-control, Direct-driven by motor	
	Motor output		kW		0.92 x 1		0.92 x 1	
*3 External static press.		0 Pa (0 mmH ₂ O)		0 Pa (0 mmH ₂ O)		0 Pa (0 mmH ₂ O)		
Compressor	Type x Quantity		Inverter scroll hermetic compressor		Inverter scroll hermetic compressor		Inverter scroll hermetic compressor	
	Manufacture		AC&R Works, MITSUBISHI ELECTRIC CORPORATION		AC&R Works, MITSUBISHI ELECTRIC CORPORATION		AC&R Works, MITSUBISHI ELECTRIC CORPORATION	
	Starting method		Inverter		Inverter		Inverter	
	Motor output		kW		4.8		6.8	
	Case heater		kW		0.035(240 V)		0.045(240 V)	
	Lubricant		MEL32		MEL32		MEL32	
External finish			Pre-coated galvanized steel sheets (+powder coating for -BS type) <MUNSELL 5Y 8/1 or similar>		Pre-coated galvanized steel sheets (+powder coating for -BS type) <MUNSELL 5Y 8/1 or similar>		Pre-coated galvanized steel sheets (+powder coating for -BS type) <MUNSELL 5Y 8/1 or similar>	
External dimension HxWxD			mm		1,710(1,650 without legs) x 920 x 760		1,710(1,650 without legs) x 920 x 760	
			in.		67-3/8(65 without legs) x 36-1/4 x 29-15/16		67-3/8(65 without legs) x 36-1/4 x 29-15/16	
Protection devices	High pressure protection		High pressure sensor, High pressure switch at 4.15,3.3MPa (601,479 psi)		High pressure sensor, High pressure switch at 4.15,3.3MPa (601,479 psi)		High pressure sensor, High pressure switch at 4.15,3.3MPa (601,479 psi)	
	Inverter circuit (COMP. / FAN)		Over-heat protection, Over-current protection		Over-heat protection, Over-current protection		Over-heat protection, Over-current protection	
	Compressor		Over-heat protection		Over-heat protection		Over-heat protection	
	Fan motor		Thermal switch		Thermal switch		Thermal switch	
Refrigerant	Type x original charge		R410A x 6.5kg (15lbs)		R410A x 9.0kg (20lbs)		R410A x 9.0kg (20lbs)	
	Control		LEV and HIC circuit		LEV and HIC circuit		LEV and HIC circuit	
Net weight			kg (lbs)		230(508)		255(563)	
Heat exchanger			Salt-resistant cross fin & copper tube		Salt-resistant cross fin & copper tube		Salt-resistant cross fin & copper tube	
HIC circuit (HIC: Heat Inter-Changer)			Copper pipe,tube-in-tube structure		Copper pipe,tube-in-tube structure		Copper pipe,tube-in-tube structure	
Pipe between unit and distributor	Liquid pipe		mm (in.)		9.52(3/8) Brazed		9.52(3/8) Brazed	
	Gas pipe		mm (in.)		19.05(3/4) Brazed		22.2(7/8) Brazed	
Defrosting method			Auto-defrost mode (Reversed refrigerant cycle)		Auto-defrost mode (Reversed refrigerant cycle)		Auto-defrost mode (Reversed refrigerant cycle)	
Drawing	External		KD94G727		KD94G727		KD94G727	
	Wiring		KE94C490		KE94C490		KE94C490	
Standard attachment	Document		Installation Manual		Installation Manual		Installation Manual	
	Accessory		Refrigerant conn. pipe		Refrigerant conn. pipe		Refrigerant conn. pipe	
Optional parts			Outdoor Twinning kit: CMY-RP200VBK		Outdoor Twinning kit: CMY-RP200VBK		Outdoor Twinning kit: CMY-RP200VBK	
			Header: CMY-Y104/108/1010-G		Header: CMY-Y104/108/1010-G		Header: CMY-Y104/108/1010-G	
Remarks			<ul style="list-style-type: none"> ●Details on foundation work, duct work, insulation work, electrical wiring, power source switch, and other items shall be referred to the Installation Manual. ●Due to continuing improvement, above specifications may be subject to change without notice. ●Our company is unable to guarantee reliability of pre-existing pipes and pre-existing cables. 					

Notes :

- Nominal cooling conditions (subject to JIS B8615-1)
Indoor: 27°CDB/19°CWB (81°FDB/66°FWB), Outdoor: 35°CDB (95°FDB)
Pipe length: 7.5 m (24-9/16 ft.), Level difference: 0 m (0 ft.)
- Nominal heating conditions (subject to JIS B8615-1)
Indoor: 20°CDB (68°FDB), Outdoor: 7°CDB/6°CWB (45°FDB/43°FWB)
Pipe length: 7.5 m (24-9/16 ft.), Level difference: 0 m (0 ft.)
- External static pressure option is available (30 Pa, 60 Pa/3.1 mmH₂O, 6.1 mmH₂O).

Unit converter

kcal	=kW x 860
BTU/h	=kW x 3,412
cfm	=m ³ /min x 35.31
lbs	=kg / 0.4536
*The specification data is subject to rounding variation.	

1. SPECIFICATIONS

Model			PUHY-RP750YSJM-B(-BS)			
Power source			3-phase 4-wire 380-400-415V 50/60Hz			
Cooling capacity (Nominal)	*1	kW	85.0			
	*1	kcal / h	73,100			
	*1	BTU / h	290,000			
		Power input	kW	24.14		
		Current input	A	40.7-38.7-37.3		
		COP	kW / kW	3.52		
Temp. range of cooling	Indoor	W.B.	15.0~24.0°C(59~75°F)			
	Outdoor	D.B.	-5.0~43.0°C(23~109°F)			
Heating capacity (Nominal)	*2	kW	95.0			
	*2	kcal / h	81,700			
	*2	BTU / h	324,100			
		Power input	kW	21.78		
		Current input	A	36.7-34.9-33.6		
		COP	kW / kW	4.36		
Temp. range of heating	Indoor	D.B.	15.0~27.0°C(59~81°F)			
	Outdoor	W.B.	-20.0~15.5°C(-4~60°F)			
Indoor unit connectable	Total capacity	50~130 % of outdoor unit capacity				
	Model / Quantity	P15~P250 / 1~32				
Sound pressure level (measured in anechoic room)		dB <A>	62			
Refrigerant piping diameter	Liquid pipe	mm (in.)	19.05(3/4) Brazed			
	Gas pipe	mm (in.)	41.28(1-5/8) Brazed			

Set Model

Model			PUHY-RP250YJM-B(-BS)	PUHY-RP250YJM-B(-BS)	PUHY-RP250YJM-B(-BS)	
FAN	Type x Quantity		Propeller fan x 1			
	Air flow rate	m ³ / min	185			
		L/s	3,083			
		cfm	6,532			
	Control , Driving mechanism		Inverter-control, Direct-driven by motor			
	Motor output	kW	0.92 x 1			
	*3 External static press.		0 Pa (0 mmH ₂ O)			
Compressor	Type x Quantity		Inverter scroll hermetic compressor			
	Manufacture		AC&R Works, MITSUBISHI ELECTRIC CORPORATION			
	Starting method		Inverter			
	Motor output	kW	6.8			
	Case heater	kW	0.045(240 V)			
	Lubricant		MEL32			
External finish			Pre-coated galvanized steel sheets (+powder coating for -BS type) <MUNSELL 5Y 8/1 or similar>		Pre-coated galvanized steel sheets (+powder coating for -BS type) <MUNSELL 5Y 8/1 or similar>	
External dimension HxWxD			mm		mm	
			1,710(1,650 without legs) x 920 x 760		1,710(1,650 without legs) x 920 x 760	
			in.		in.	
			67-3/8(65 without legs) x 36-1/4 x 29-15/16		67-3/8(65 without legs) x 36-1/4 x 29-15/16	
Protection devices	High pressure protection		High pressure sensor, High pressure switch at 4.15,3.3MPa (601,479 psi)		High pressure sensor, High pressure switch at 4.15,3.3MPa (601,479 psi)	
	Inverter circuit (COMP. / FAN)		Over-heat protection, Over-current protection		Over-heat protection, Over-current protection	
	Compressor		Over-heat protection		Over-heat protection	
	Fan motor		Thermal switch		Thermal switch	
Refrigerant	Type x original charge		R410A x 9.0kg (20lbs)		R410A x 9.0kg (20lbs)	
	Control		LEV and HIC circuit			
Net weight		kg (lbs)	255(563)		255(563)	
Heat exchanger			Salt-resistant cross fin & copper tube		Salt-resistant cross fin & copper tube	
HIC circuit (HIC: Heat Inter-Changer)			Copper pipe,tube-in-tube structure		Copper pipe,tube-in-tube structure	
Pipe between unit and distributor	Liquid pipe	mm (in.)	9.52(3/8) Brazed		9.52(3/8) Brazed	
	Gas pipe	mm (in.)	22.2(7/8) Brazed		22.2(7/8) Brazed	
Defrosting method			Auto-defrost mode (Reversed refrigerant cycle)			
Drawing	External		KD94G727			
	Wiring		KE94C490		KE94C490	
Standard attachment	Document		Installation Manual			
	Accessory		Refrigerant conn. pipe			
Optional parts			Outdoor Twinning kit: CMY-RP200VBK Header: CMY-Y104/108/1010-G			
Remarks			<ul style="list-style-type: none"> •Details on foundation work, duct work, insulation work, electrical wiring, power source switch, and other items shall be referred to the Installation Manual. •Due to continuing improvement, above specifications may be subject to change without notice. •Our company is unable to guarantee reliability of pre-existing pipes and pre-existing cables. 			

Notes :

- Nominal cooling conditions (subject to JIS B8615-1)
Indoor: 27°CDB/19°CWB (81°FDB/66°FWB), Outdoor: 35°CDB (95°FDB)
Pipe length: 7.5 m (24-9/16 ft.), Level difference: 0 m (0 ft.)
- Nominal heating conditions (subject to JIS B8615-1)
Indoor: 20°CDB (68°FDB), Outdoor: 7°CDB/6°CWB (45°FDB/43°FWB)
Pipe length: 7.5 m (24-9/16 ft.), Level difference: 0 m (0 ft.)
- External static pressure option is available (30 Pa, 60 Pa/3.1 mmH₂O, 6.1 mmH₂O).

Unit converter	
kcal	=kW x 860
BTU/h	=kW x 3,412
cfm	=m ³ /min x 35.31
lbs	=kg / 0.4536
*The specification data is subject to rounding variation.	

1. SPECIFICATIONS

Model			PUHY-RP800YSJM-B(-BS)		
Power source			3-phase 4-wire 380-400-415V 50/60Hz		
Cooling capacity (Nominal)	*1	kW	90.0		
	*1	kcal / h	77,400		
	*1	BTU / h	307,100		
		Power input	kW		
		Current input	A		
		43.0-40.8-39.4			
		COP		kW / kW	
				3.53	
Temp. range of cooling	Indoor	W.B.	15.0~24.0°C(59~75°F)		
	Outdoor	D.B.	-5.0~43.0°C(23~109°F)		
Heating capacity (Nominal)	*2	kW	100.0		
	*2	kcal / h	86,000		
	*2	BTU / h	341,200		
		Power input	kW		
		Current input	A		
		40.0-38.0-36.7			
		COP		kW / kW	
				4.21	
Temp. range of heating	Indoor	D.B.	15.0~27.0°C(59~81°F)		
	Outdoor	W.B.	-20.0~15.5°C(-4~60°F)		
Indoor unit connectable	Total capacity	50~130 % of outdoor unit capacity			
	Model / Quantity	P15~P250 / 1~32			
Sound pressure level (measured in anechoic room)			dB <A>		
			62.5		
Refrigerant piping diameter	Liquid pipe	mm (in.)	19.05(3/4) Brazed		
	Gas pipe	mm (in.)	41.28(1-5/8) Brazed		

Set Model

Model			PUHY-RP250YJM-B(-BS)		PUHY-RP250YJM-B(-BS)		PUHY-RP300YJM-B(-BS)	
FAN	Type x Quantity		Propeller fan x 1		Propeller fan x 1		Propeller fan x 1	
	Air flow rate	m ³ / min	185		185		185	
		L/s	3,083		3,083		3,083	
		cfm	6,532		6,532		6,532	
	Control , Driving mechanism		Inverter-control, Direct-driven by motor		Inverter-control, Direct-driven by motor		Inverter-control, Direct-driven by motor	
	Motor output	kW	0.92 x 1		0.92 x 1		0.92 x 1	
*3 External static press.		0 Pa (0 mmH ₂ O)		0 Pa (0 mmH ₂ O)		0 Pa (0 mmH ₂ O)		
Compressor	Type x Quantity		Inverter scroll hermetic compressor		Inverter scroll hermetic compressor		Inverter scroll hermetic compressor	
	Manufacture		AC&R Works, MITSUBISHI ELECTRIC CORPORATION		AC&R Works, MITSUBISHI ELECTRIC CORPORATION		AC&R Works, MITSUBISHI ELECTRIC CORPORATION	
	Starting method		Inverter		Inverter		Inverter	
	Motor output	kW	6.8		6.8		8.2	
	Case heater	kW	0.045(240 V)		0.045(240 V)		0.045(240 V)	
	Lubricant		MEL32		MEL32		MEL32	
External finish			Pre-coated galvanized steel sheets (+powder coating for -BS type) <MUNSELL 5Y 8/1 or similar>		Pre-coated galvanized steel sheets (+powder coating for -BS type) <MUNSELL 5Y 8/1 or similar>		Pre-coated galvanized steel sheets (+powder coating for -BS type) <MUNSELL 5Y 8/1 or similar>	
External dimension HxWxD			mm		mm		mm	
			1,710(1,650 without legs) x 920 x 760		1,710(1,650 without legs) x 920 x 760		1,710(1,650 without legs) x 920 x 760	
			in.		in.		in.	
			67-3/8(65 without legs) x 36-1/4 x 29-15/16		67-3/8(65 without legs) x 36-1/4 x 29-15/16		67-3/8(65 without legs) x 36-1/4 x 29-15/16	
Protection devices	High pressure protection		High pressure sensor, High pressure switch at 4.15,3.3MPa (601,479 psi)		High pressure sensor, High pressure switch at 4.15,3.3MPa (601,479 psi)		High pressure sensor, High pressure switch at 4.15,3.3MPa (601,479 psi)	
	Inverter circuit (COMP. / FAN)		Over-heat protection, Over-current protection		Over-heat protection, Over-current protection		Over-heat protection, Over-current protection	
	Compressor		Over-heat protection		Over-heat protection		Over-heat protection	
	Fan motor		Thermal switch		Thermal switch		Thermal switch	
Refrigerant	Type x original charge		R410A x 9.0kg (20lbs)		R410A x 9.0kg (20lbs)		R410A x 9.0kg (20lbs)	
	Control		LEV and HIC circuit					
Net weight			kg (lbs)		255(563)		255(563)	
Heat exchanger			Salt-resistant cross fin & copper tube		Salt-resistant cross fin & copper tube		Salt-resistant cross fin & copper tube	
HIC circuit (HIC: Heat Inter-Changer)			Copper pipe,tube-in-tube structure					
Pipe between unit and distributor	Liquid pipe	mm (in.)	9.52(3/8) Brazed		9.52(3/8) Brazed		12.7(1/2) Brazed	
	Gas pipe	mm (in.)	22.2(7/8) Brazed		22.2(7/8) Brazed		22.2(7/8) Brazed	
Defrosting method			Auto-defrost mode (Reversed refrigerant cycle)					
Drawing	External		KD94G727					
	Wiring		KE94C490		KE94C490		KE94C490	
Standard attachment	Document		Installation Manual					
	Accessory		Refrigerant conn. pipe					
Optional parts			Outdoor Twinning kit: CMY-RP200VBK Header: CMY-Y104/108/1010-G					
Remarks			<ul style="list-style-type: none"> ●Details on foundation work, duct work, insulation work, electrical wiring, power source switch, and other items shall be referred to the Installation Manual. ●Due to continuing improvement, above specifications may be subject to change without notice. ●Our company is unable to guarantee reliability of pre-existing pipes and pre-existing cables. 					

Notes :

- Nominal cooling conditions (subject to JIS B8615-1)
Indoor: 27°CDB/19°CWB (81°FDB/66°FWB), Outdoor: 35°CDB (95°FDB)
Pipe length: 7.5 m (24-9/16 ft.), Level difference: 0 m (0 ft.)
- Nominal heating conditions (subject to JIS B8615-1)
Indoor: 20°CDB (68°FDB), Outdoor: 7°CDB/6°CWB (45°FDB/43°FWB)
Pipe length: 7.5 m (24-9/16 ft.), Level difference: 0 m (0 ft.)
- External static pressure option is available (30 Pa, 60 Pa/3.1 mmH₂O, 6.1 mmH₂O).

Unit converter

kcal	=kW x 860
BTU/h	=kW x 3,412
cfm	=m ³ /min x 35.31
lbs	=kg / 0.4536
*The specification data is subject to rounding variation.	

1. SPECIFICATIONS

Model			PUHY-RP850YSJM-B(-BS)		
Power source			3-phase 4-wire 380-400-415V 50/60Hz		
Cooling capacity (Nominal)	*1	kW	96.0		
	*1	kcal / h	82,600		
	*1	BTU / h	327,600		
		Power input	kW	27.11	
		Current input	A	45.7-43.4-41.9	
		COP	kW / kW		3.54
Temp. range of cooling	Indoor	W.B.	15.0~24.0°C(59~75°F)		
	Outdoor	D.B.	-5.0~43.0°C(23~109°F)		
Heating capacity (Nominal)	*2	kW	108.0		
	*2	kcal / h	92,900		
	*2	BTU / h	368,500		
		Power input	kW	26.47	
		Current input	A	44.6-42.4-40.9	
		COP	kW / kW		4.08
Temp. range of heating	Indoor	D.B.	15.0~27.0°C(59~81°F)		
	Outdoor	W.B.	-20.0~15.5°C(-4~60°F)		
Indoor unit connectable	Total capacity	50~130 % of outdoor unit capacity			
	Model / Quantity	P15~P250 / 1~32			
Sound pressure level (measured in anechoic room)	dB <A>	63.5			
Refrigerant piping diameter	Liquid pipe	mm (in.)	19.05(3/4) Brazed		
	Gas pipe	mm (in.)	41.28(1-5/8) Brazed		

Set Model

Model			PUHY-RP250YJM-B(-BS)	PUHY-RP300YJM-B(-BS)	PUHY-RP300YJM-B(-BS)
FAN	Type x Quantity		Propeller fan x 1	Propeller fan x 1	Propeller fan x 1
	Air flow rate	m ³ / min	185	185	185
		L/s	3,083	3,083	3,083
		cfm	6,532	6,532	6,532
	Control , Driving mechanism		Inverter-control, Direct-driven by motor	Inverter-control, Direct-driven by motor	Inverter-control, Direct-driven by motor
	Motor output	kW	0.92 x 1	0.92 x 1	0.92 x 1
*3 External static press.		0 Pa (0 mmH ₂ O)	0 Pa (0 mmH ₂ O)	0 Pa (0 mmH ₂ O)	
Compressor	Type x Quantity		Inverter scroll hermetic compressor	Inverter scroll hermetic compressor	Inverter scroll hermetic compressor
	Manufacture		AC&R Works, MITSUBISHI ELECTRIC CORPORATION	AC&R Works, MITSUBISHI ELECTRIC CORPORATION	AC&R Works, MITSUBISHI ELECTRIC CORPORATION
	Starting method		Inverter	Inverter	Inverter
	Motor output	kW	6.8	8.2	8.2
	Case heater	kW	0.045(240 V)	0.045(240 V)	0.045(240 V)
	Lubricant		MEL32	MEL32	MEL32
External finish			Pre-coated galvanized steel sheets (+powder coating for -BS type) <MUNSELL 5Y 8/1 or similar>	Pre-coated galvanized steel sheets (+powder coating for -BS type) <MUNSELL 5Y 8/1 or similar>	Pre-coated galvanized steel sheets (+powder coating for -BS type) <MUNSELL 5Y 8/1 or similar>
External dimension HxWxD			mm 1,710(1,650 without legs) x 920 x 760 67-3/8(65 without legs) x 36-1/4 x 29-15/16	mm 1,710(1,650 without legs) x 920 x 760 67-3/8(65 without legs) x 36-1/4 x 29-15/16	mm 1,710(1,650 without legs) x 920 x 760 67-3/8(65 without legs) x 36-1/4 x 29-15/16
Protection devices	High pressure protection		High pressure sensor, High pressure switch at 4.15,3.3MPa (601,479 psi)	High pressure sensor, High pressure switch at 4.15,3.3MPa (601,479 psi)	High pressure sensor, High pressure switch at 4.15,3.3MPa (601,479 psi)
	Inverter circuit (COMP. / FAN)		Over-heat protection, Over-current protection	Over-heat protection, Over-current protection	Over-heat protection, Over-current protection
	Compressor		Over-heat protection	Over-heat protection	Over-heat protection
	Fan motor		Thermal switch	Thermal switch	Thermal switch
Refrigerant	Type x original charge		R410A x 9.0kg (20lbs)	R410A x 9.0kg (20lbs)	R410A x 9.0kg (20lbs)
	Control		LEV and HIC circuit		
Net weight	kg (lbs)	255(563)	255(563)	255(563)	
Heat exchanger			Salt-resistant cross fin & copper tube	Salt-resistant cross fin & copper tube	Salt-resistant cross fin & copper tube
HIC circuit (HIC: Heat Inter-Changer)			Copper pipe,tube-in-tube structure	Copper pipe,tube-in-tube structure	Copper pipe,tube-in-tube structure
Pipe between unit and distributor	Liquid pipe	mm (in.)	9.52(3/8) Brazed	12.7(1/2) Brazed	12.7(1/2) Brazed
	Gas pipe	mm (in.)	22.2(7/8) Brazed	22.2(7/8) Brazed	22.2(7/8) Brazed
Defrosting method			Auto-defrost mode (Reversed refrigerant cycle)		
Drawing	External		KD94G727		
	Wiring		KE94C490	KE94C490	KE94C490
Standard attachment	Document		Installation Manual		
	Accessory		Refrigerant conn. pipe		
Optional parts			Outdoor Twinning kit: CMY-RP200VBK Header: CMY-Y104/108/1010-G		
Remarks			<ul style="list-style-type: none"> •Details on foundation work, duct work, insulation work, electrical wiring, power source switch, and other items shall be referred to the Installation Manual. •Due to continuing improvement, above specifications may be subject to change without notice. •Our company is unable to guarantee reliability of pre-existing pipes and pre-existing cables. 		

Notes :

- Nominal cooling conditions (subject to JIS B8615-1)
Indoor: 27°CDB/19°CWB (81°FDB/66°FWB), Outdoor: 35°CDB (95°FDB)
Pipe length: 7.5 m (24-9/16 ft.), Level difference: 0 m (0 ft.)
- Nominal heating conditions (subject to JIS B8615-1)
Indoor: 20°CDB (68°FDB), Outdoor: 7°CDB/6°CWB (45°FDB/43°FWB)
Pipe length: 7.5 m (24-9/16 ft.), Level difference: 0 m (0 ft.)
- External static pressure option is available (30 Pa, 60 Pa/3.1 mmH₂O, 6.1 mmH₂O).

Unit converter	
kcal	=kW x 860
BTU/h	=kW x 3,412
cfm	=m ³ /min x 35.31
lbs	=kg / 0.4536
*The specification data is subject to rounding variation.	

1. SPECIFICATIONS

Model			PUHY-RP900YSJM-B(-BS)		
Power source			3-phase 4-wire 380-400-415V 50/60Hz		
Cooling capacity (Nominal)	*1	kW	101.0		
	*1	kcal / h	86,900		
	*1	BTU / h	344,600		
		Power input	kW	28.29	
		Current input	A	47.7-45.3-43.7	
		COP	kW / kW		3.57
Temp. range of cooling	Indoor	W.B.	15.0~24.0°C(59~75°F)		
	Outdoor	D.B.	-5.0~43.0°C(23~109°F)		
Heating capacity (Nominal)	*2	kW	113.0		
	*2	kcal / h	97,200		
	*2	BTU / h	385,600		
		Power input	kW	28.39	
		Current input	A	47.9-45.5-43.8	
		COP	kW / kW		3.98
Temp. range of heating	Indoor	D.B.	15.0~27.0°C(59~81°F)		
	Outdoor	W.B.	-20.0~15.5°C(-4~60°F)		
Indoor unit connectable	Total capacity	50~130 % of outdoor unit capacity			
	Model / Quantity	P15~P250 / 1~32			
Sound pressure level (measured in anechoic room)			dB <A>		64
Refrigerant piping diameter	Liquid pipe	mm (in.)	19.05(3/4) Brazed		
	Gas pipe	mm (in.)	41.28(1-5/8) Brazed		

Set Model

Model			PUHY-RP300YJM-B(-BS)		PUHY-RP300YJM-B(-BS)		PUHY-RP300YJM-B(-BS)	
FAN	Type x Quantity		Propeller fan x 1		Propeller fan x 1		Propeller fan x 1	
	Air flow rate	m ³ / min	185		185		185	
		L/s	3,083		3,083		3,083	
		cfm	6,532		6,532		6,532	
	Control , Driving mechanism		Inverter-control, Direct-driven by motor		Inverter-control, Direct-driven by motor		Inverter-control, Direct-driven by motor	
	Motor output	kW	0.92 x 1		0.92 x 1		0.92 x 1	
*3 External static press.		0 Pa (0 mmH ₂ O)		0 Pa (0 mmH ₂ O)		0 Pa (0 mmH ₂ O)		
Compressor	Type x Quantity		Inverter scroll hermetic compressor		Inverter scroll hermetic compressor		Inverter scroll hermetic compressor	
	Manufacture		AC&R Works, MITSUBISHI ELECTRIC CORPORATION		AC&R Works, MITSUBISHI ELECTRIC CORPORATION		AC&R Works, MITSUBISHI ELECTRIC CORPORATION	
	Starting method		Inverter		Inverter		Inverter	
	Motor output	kW	8.2		8.2		8.2	
	Case heater	kW	0.045(240 V)		0.045(240 V)		0.045(240 V)	
	Lubricant		MEL32		MEL32		MEL32	
External finish			Pre-coated galvanized steel sheets (+powder coating for -BS type) <MUNSELL 5Y 8/1 or similar>		Pre-coated galvanized steel sheets (+powder coating for -BS type) <MUNSELL 5Y 8/1 or similar>		Pre-coated galvanized steel sheets (+powder coating for -BS type) <MUNSELL 5Y 8/1 or similar>	
External dimension HxWxD			mm 1,710(1,650 without legs) x 920 x 760		mm 1,710(1,650 without legs) x 920 x 760		mm 1,710(1,650 without legs) x 920 x 760	
			in. 67-3/8(65 without legs) x 36-1/4 x 29-15/16		in. 67-3/8(65 without legs) x 36-1/4 x 29-15/16		in. 67-3/8(65 without legs) x 36-1/4 x 29-15/16	
Protection devices	High pressure protection		High pressure sensor, High pressure switch at 4.15,3.3MPa (601,479 psi)		High pressure sensor, High pressure switch at 4.15,3.3MPa (601,479 psi)		High pressure sensor, High pressure switch at 4.15,3.3MPa (601,479 psi)	
	Inverter circuit (COMP. / FAN)		Over-heat protection, Over-current protection		Over-heat protection, Over-current protection		Over-heat protection, Over-current protection	
	Compressor		Over-heat protection		Over-heat protection		Over-heat protection	
	Fan motor		Thermal switch		Thermal switch		Thermal switch	
Refrigerant	Type x original charge		R410A x 9.0kg (20lbs)		R410A x 9.0kg (20lbs)		R410A x 9.0kg (20lbs)	
	Control		LEV and HIC circuit					
Net weight			kg (lbs)		255(563)		255(563)	
Heat exchanger			Salt-resistant cross fin & copper tube		Salt-resistant cross fin & copper tube		Salt-resistant cross fin & copper tube	
HIC circuit (HIC: Heat Inter-Changer)			Copper pipe,tube-in-tube structure		Copper pipe,tube-in-tube structure		Copper pipe,tube-in-tube structure	
Pipe between unit and distributor	Liquid pipe	mm (in.)	12.7(1/2) Brazed		12.7(1/2) Brazed		12.7(1/2) Brazed	
	Gas pipe	mm (in.)	22.2(7/8) Brazed		22.2(7/8) Brazed		22.2(7/8) Brazed	
Defrosting method			Auto-defrost mode (Reversed refrigerant cycle)					
Drawing	External		KD94G727					
	Wiring		KE94C490		KE94C490		KE94C490	
Standard attachment	Document		Installation Manual					
	Accessory		Refrigerant conn. pipe					
Optional parts			Outdoor Twinning kit: CMY-RP200VBK Header: CMY-Y104/108/1010-G					
Remarks			<ul style="list-style-type: none"> ●Details on foundation work, duct work, insulation work, electrical wiring, power source switch, and other items shall be referred to the Installation Manual. ●Due to continuing improvement, above specifications may be subject to change without notice. ●Our company is unable to guarantee reliability of pre-existing pipes and pre-existing cables. 					

Notes :

- Nominal cooling conditions (subject to JIS B8615-1)
Indoor: 27°CDB/19°CWB (81°FDB/66°FWB), Outdoor: 35°CDB (95°FDB)
Pipe length: 7.5 m (24-9/16 ft.), Level difference: 0 m (0 ft.)
- Nominal heating conditions (subject to JIS B8615-1)
Indoor: 20°CDB (68°FDB), Outdoor: 7°CDB/6°CWB (45°FDB/43°FWB)
Pipe length: 7.5 m (24-9/16 ft.), Level difference: 0 m (0 ft.)
- External static pressure option is available (30 Pa, 60 Pa/3.1 mmH₂O, 6.1 mmH₂O).

Unit converter

kcal	=kW x 860
BTU/h	=kW x 3,412
cfm	=m ³ /min x 35.31
lbs	=kg / 0.4536
*The specification data is subject to rounding variation.	

2. EXTERNAL DIMENSIONS

PUHY-RP200, 250, 300, 350YJM-B-(BS)

Unit : mm

1. Required space around the unit

In case of single installation

- Secure enough space around the unit as shown in the figure below.
 - With a space of at least 300 mm to the wall on the back of the unit

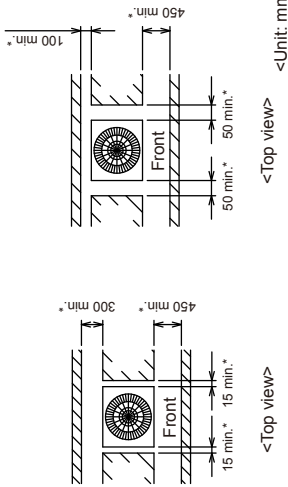

<Unit: mm>

- When the height of the walls on the front, back or on the sides <H> exceeds the wall height limit as defined below, add the height that exceeds the height limit <h> to the figures that are marked with an asterisk.

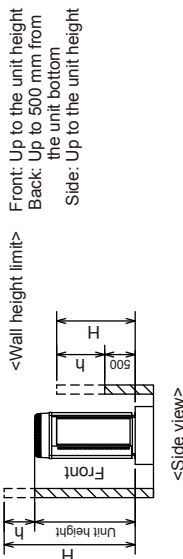

Front: Up to the unit height
Back: Up to 500 mm from the unit bottom
Side: Up to the unit height

<Side view>

2. Foundation work

- Take into consideration the surface strength, water drainage route, piping route, and wiring route when preparing the installation site.
 - Note that the drain water comes out of the unit during operation.
- Build the foundation in such way that the corner of the installation leg is securely supported as shown in the right figure. (Fig.A, B)
 - When using a rubber isolating cushion, please ensure it is large enough to cover the entire width of each of the unit's legs.
- The protrusion length of the anchor bolt must not exceed 30 mm. (Fig.A, B)
- Use four fixing plates as shown in the right figure <field supply required> when using post-installed anchor bolts. (Fig.C, D)
- To prevent small animals and water and snow from entering the unit and damaging its parts, close the gap around the edges of through holes for pipes and wires with filler plates <field supply required>.
- When the pipes or cables are routed at the bottom of the unit, make sure that the through hole at the base of the unit does not get blocked with the installation base.
- Refer to the Installation Manual when installing units on an installation base.

In case of collective installation

- When multiple units are installed adjacent to each other, secure enough space to allow for air circulation and walkway between groups of units, as shown in the figures below.
- At least two sides must be left open.
- As with the single installation, add the height that exceeds the height limit <h> to the figures that are marked with an asterisk.
- If there is a wall at both the front and the rear of the unit, install up to six units consecutively in the side direction and provide a space of 1000 mm or more as inlet space/ passage space for each six units.

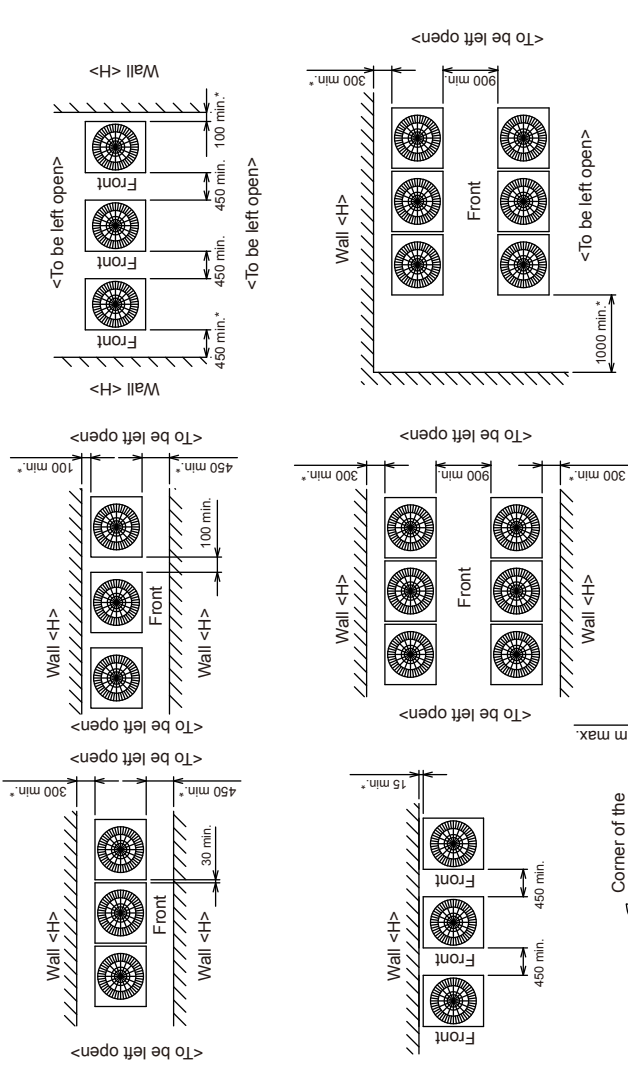

<Unit: mm>

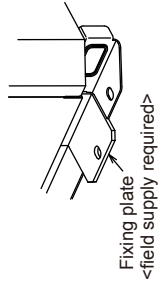

Fig.C (without detachable legs)

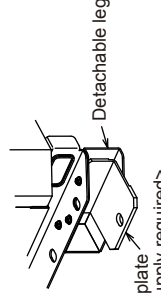

Fig.D (with detachable legs)

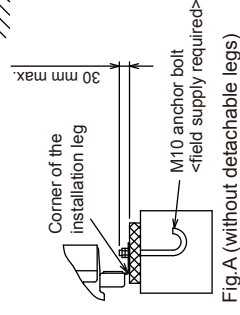

Fig.A (without detachable legs)

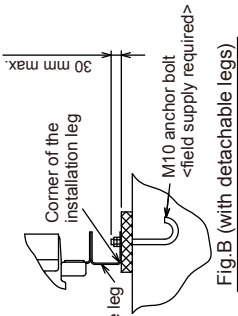
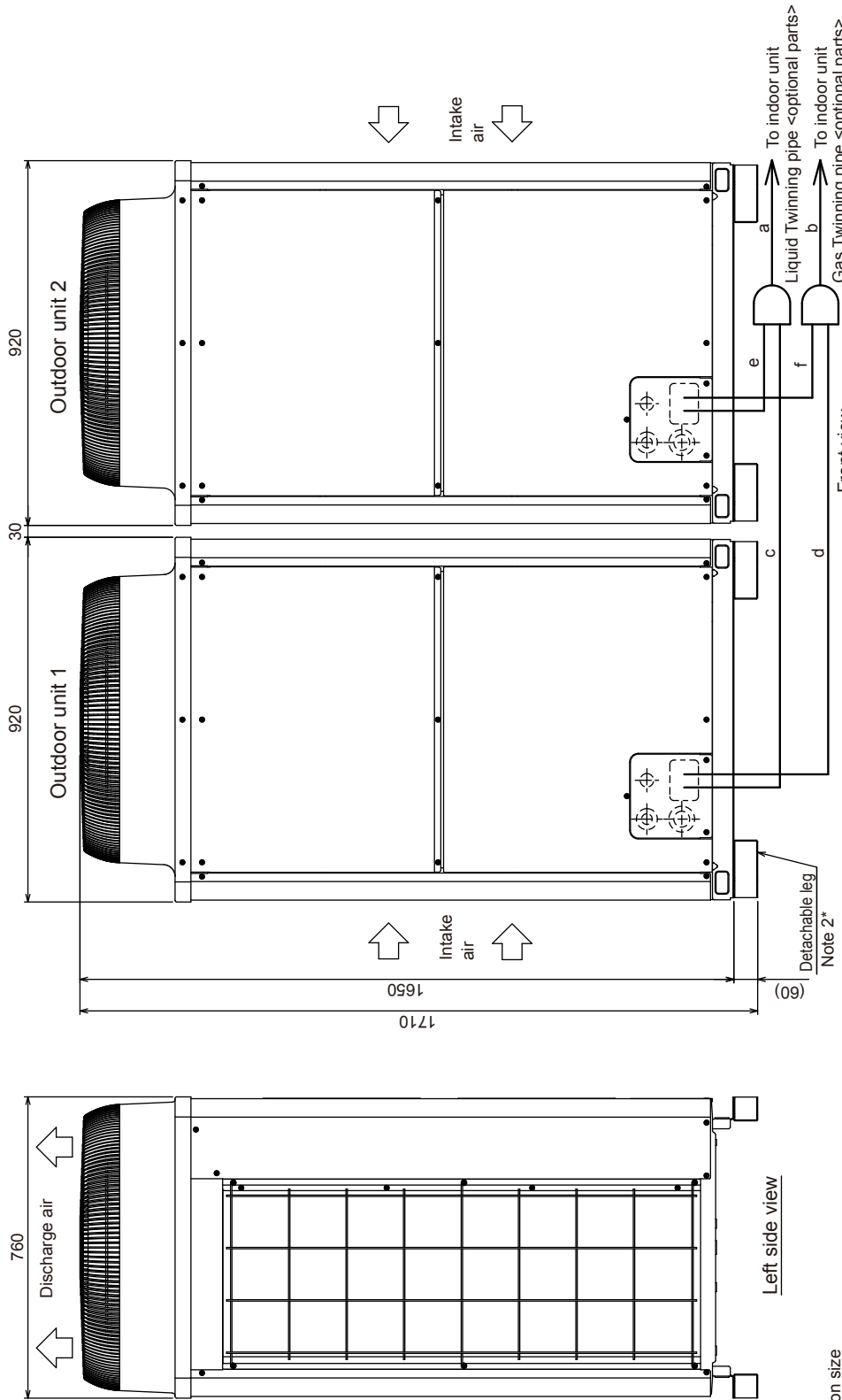

Fig.B (with detachable legs)

2. EXTERNAL DIMENSIONS

PUHY-RP400, 450, 500, 550, 600, 650YSJM-B(-BS)

Unit : mm



Twinning pipe connection size

Package unit name	PUHY-RP400YSJM-B(-BS)	PUHY-RP450YSJM-B(-BS)	PUHY-RP500YSJM-B(-BS)	PUHY-RP550YSJM-B(-BS)	PUHY-RP600YSJM-B(-BS)	PUHY-RP650YSJM-B(-BS)
Outdoor unit 1	PUHY-RP200YSJM-B(-BS)	PUHY-RP250YSJM-B(-BS)	PUHY-RP300YSJM-B(-BS)	PUHY-RP350YSJM-B(-BS)	PUHY-RP400YSJM-B(-BS)	PUHY-RP450YSJM-B(-BS)
Outdoor unit 2	PUHY-RP200YSJM-B(-BS)	PUHY-RP250YSJM-B(-BS)	PUHY-RP300YSJM-B(-BS)	PUHY-RP350YSJM-B(-BS)	PUHY-RP400YSJM-B(-BS)	PUHY-RP450YSJM-B(-BS)
Outdoor Twinning Kit (optional parts)	PUHY-RP200YSJM-B(-BS)	PUHY-RP250YSJM-B(-BS)	PUHY-RP300YSJM-B(-BS)	PUHY-RP350YSJM-B(-BS)	PUHY-RP400YSJM-B(-BS)	PUHY-RP450YSJM-B(-BS)
Indoor unit-Twinning pipe	Liquid	ø15.88		ø19.05		ø41.28
	Gas	ø15.88		ø19.05		ø41.28

Unit model	Gas	Liquid
RP200	d or f	c or e
RP250	ø19.05	ø9.52
RP300	ø22.2	ø9.52
RP350	ø22.2	ø12.7
RP400	ø28.58	ø12.7

- Note 1. Connect the pipes as shown in the figure above. Refer to the table above for the pipe size.
 2. The detachable leg can be removed at site.
 3. Twinning pipes should not be tilted more than 15 degrees from the horizontal plane. Be sure to see the Installation Manual for details of Twinning pipe installation.
 4. The pipe section before the Twinning pipe (sections "a" and "b" in the figure) must have at least 500 mm of straight section (*including the straight pipe that is supplied with the Twinning pipe).
 5. Only use the Twinning pipe by Mitsubishi (optional parts).

2. EXTERNAL DIMENSIONS

PUHY-RP700, 750, 800, 850, 900YSJM-B(-BS)

Unit : mm

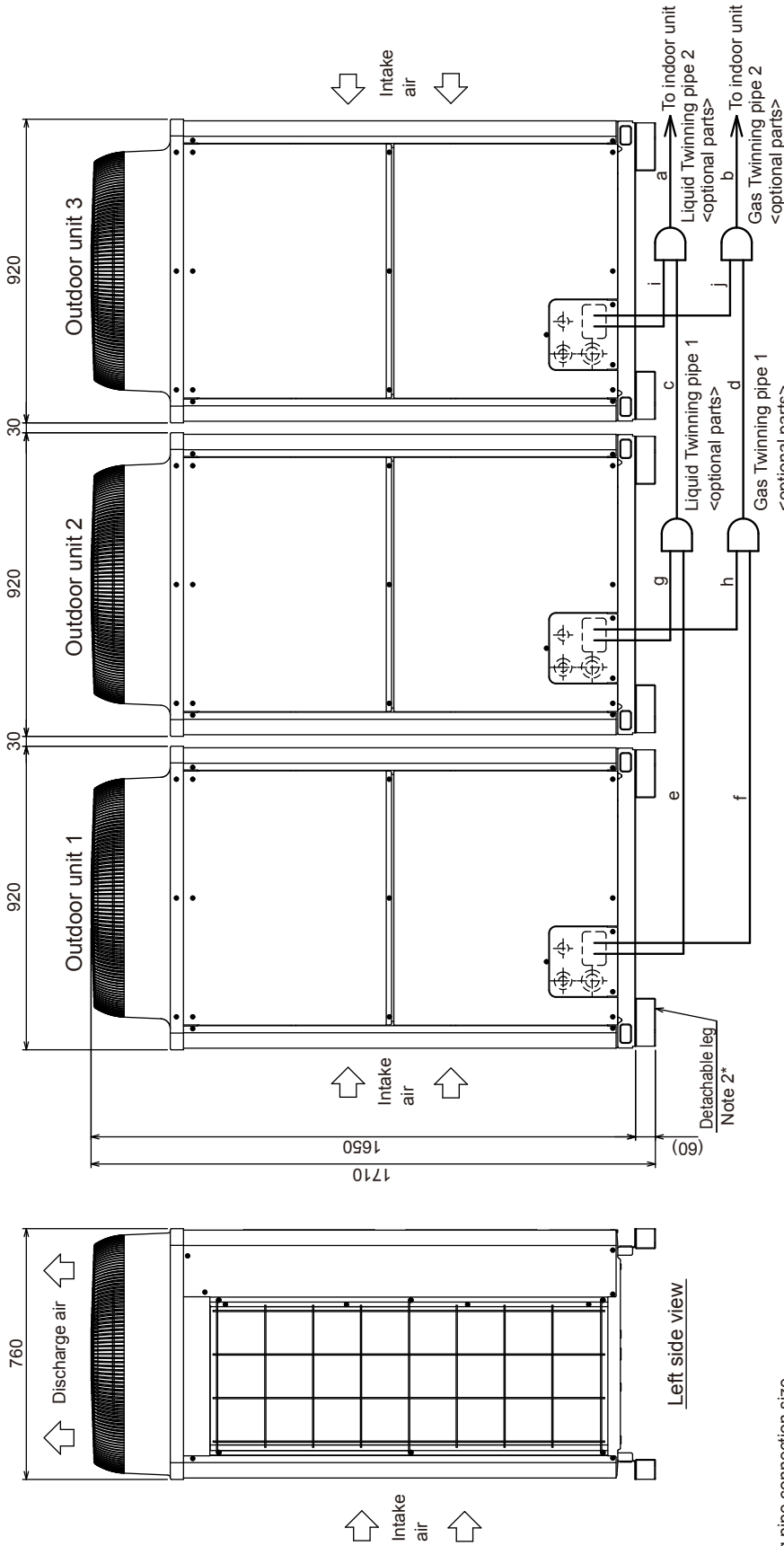

Front view

Left side view

Twinning pipe connection size

Package unit name	PUHY-RP700YSJM-B(-BS)	PUHY-RP750YSJM-B(-BS)	PUHY-RP800YSJM-B(-BS)	PUHY-RP850YSJM-B(-BS)	PUHY-RP900YSJM-B(-BS)
Outdoor unit 1	PUHY-RP250YJM-B(-BS)	PUHY-RP250YJM-B(-BS)	PUHY-RP250YJM-B(-BS)	PUHY-RP300YJM-B(-BS)	PUHY-RP300YJM-B(-BS)
Outdoor unit 2	PUHY-RP250YJM-B(-BS)	PUHY-RP250YJM-B(-BS)	PUHY-RP250YJM-B(-BS)	PUHY-RP300YJM-B(-BS)	PUHY-RP300YJM-B(-BS)
Outdoor unit 3	PUHY-RP200YJM-B(-BS)	PUHY-RP250YJM-B(-BS)	PUHY-RP250YJM-B(-BS)	PUHY-RP250YJM-B(-BS)	PUHY-RP300YJM-B(-BS)
Outdoor Twinning Kit (optional parts)	CNY-RP200VBK				
Liquid a	ø19.05				
Gas b	ø41.28				
Liquid c	ø19.05				
Gas d	ø34.93				
Liquid e or g or i for h or j	RP200		RP250		RP300
Gas	ø19.05		ø22.2		ø22.2

Note 1. Connect the pipes as shown in the figure above. Refer to the table above for the pipe size.

2. The detachable leg can be removed at site.

3. Twinning pipes should not be tilted more than 15 degrees from the horizontal plane.

Be sure to see the Installation Manual for details of Twinning pipe installation.

4. The pipe section before the Twinning pipe (sections "a", "b", "c" and "d" in the figure) must have at least 500 mm of straight section

(*including the straight pipe that is supplied with the Twinning pipe).

5. Only use the Twinning pipe by Mitsubishi (optional parts).

Unit model	Liquid e or g or i for h or j	Gas
RP200	ø19.05	ø19.05
RP250	ø19.05	ø22.2
RP300	ø19.05	ø22.2

Twinning pipe~Outdoor unit

3. CENTER OF GRAVITY

PUHY-RP200, RP250, RP300, RP350YJM-B(-BS)

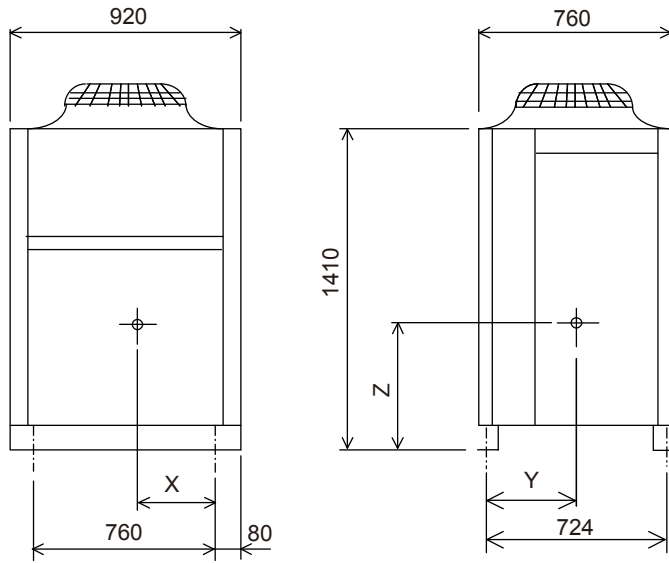

Unit: mm

Model	X	Y	Z
PUHY-RP200YJM-B(-BS)	330	337	550
PUHY-RP250YJM-B(-BS)	325	342	550
PUHY-RP300YJM-B(-BS)	325	352	550
PUHY-RP350YJM-B(-BS)	325	352	550

4. ELECTRICAL WIRING DIAGRAMS

PUHY-RP200, 250, 300, 350YJM-B-(BS)

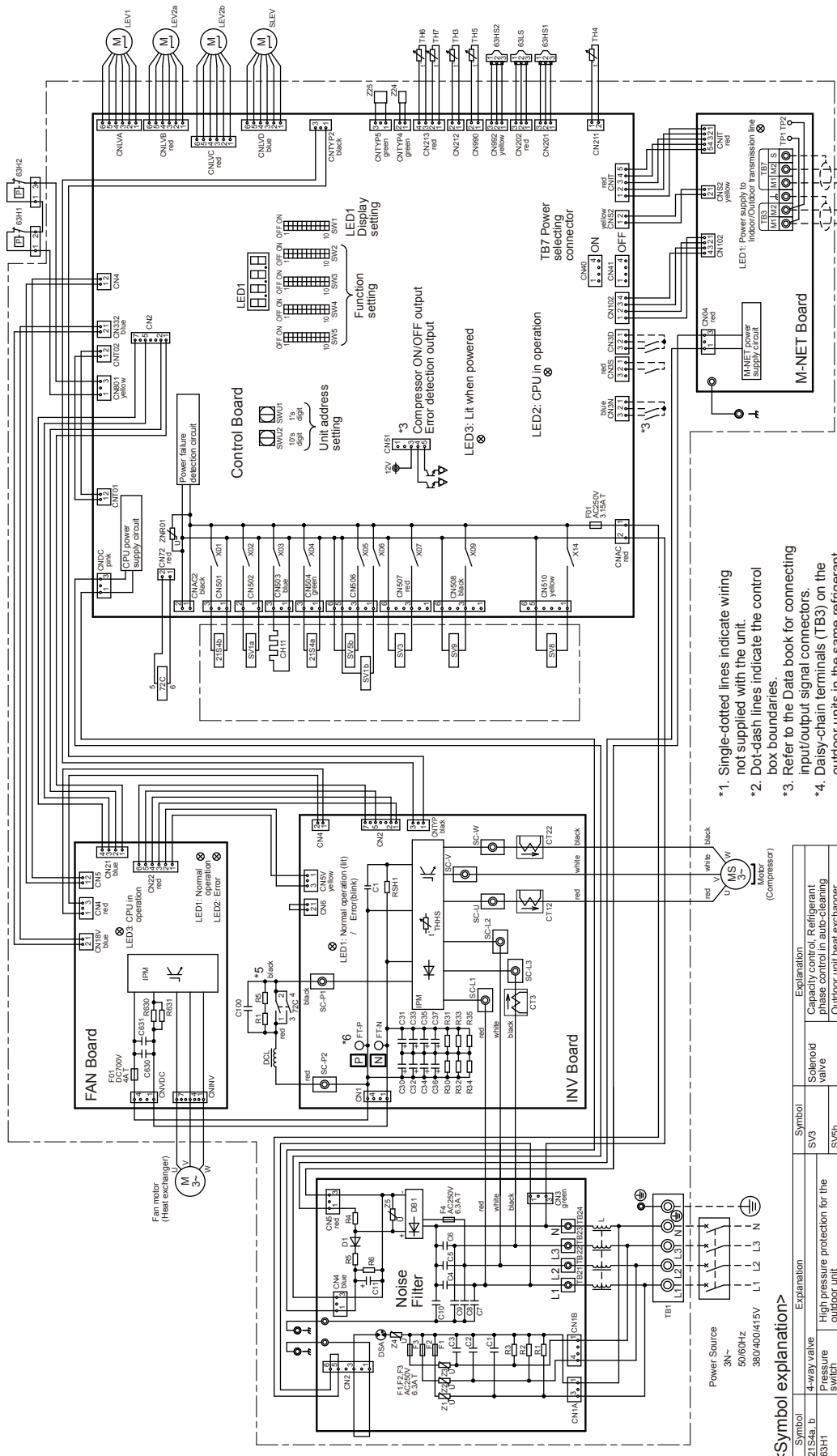

- *1. Single-dotted lines indicate wiring not supplied with the unit.
- *2. Dot-dash lines indicate the control box boundaries.
- *3. Refer to the Data book for connecting input/output signal connectors.
- *4. Daisy-chain terminals (TB3) on the outdoor units in the same refrigerant system together.
- *5. Faston terminals have a locking function. Make sure the terminals are securely locked in place after insertion. Press the tab on the terminals to remove them.
- *6. Control box houses high-voltage parts. Before inspecting the inside of the control box, turn off the power; keep the unit off for at least 10 minutes, and confirm that the voltage between FT-P and FT-N on INV Board has dropped to DC200V or less.

<Symbol explanation>

Symbol	Explanation	Symbol	Explanation
21S4b, b	4-way valve	SV3	Solenoid valve
63H1	High pressure protection for the outdoor unit	SV5b	Capacity control Refrigerant phase control in auto-cleaning
63H2	Pressure protection for pre-existing pipes	SV6	Outdoor unit heat exchanger capacity control
63HS1	Pressure protection for pre-existing pipes	SV9	Refrigerant charging port for auto-charge
63LS2	Discharge pressure	TB1	For opening/closing the bypass
72C	Low pressure	TB3	Power supply
72C	Magnetic relay (inverter main circuit)	TB7	Indoor/Outdoor transmission cable
CH11	Crankcase heater (for heating the compressor)	TB3	Central control transmission cable
DC1	DC reactor	TH3	Pipe temperature
SLEV	Oil flow control	TH4	Discharge pipe temperature
LEV1	Linear expansion valve	TH5	ACC inlet pipe temperature
LEV2a, b	HIC bypass, Controls refrigerant flow in HIC circuit	TH6	Subcooled liquid refrigerant temperature
SV1a	Pressure control, Refrigerant flow rate control	TH7	RA temperature
SV1a	For opening/closing the bypass circuit under the O/S	TH8	IP temperature
SV1b	Solenoid valve	Z2a, 25	Function setting connector
SV1b	For opening/closing the bypass circuit		

5. SOUND LEVELS

Measurement condition PUHY-RP200, 250, 300, 350YJM-B(-BS)

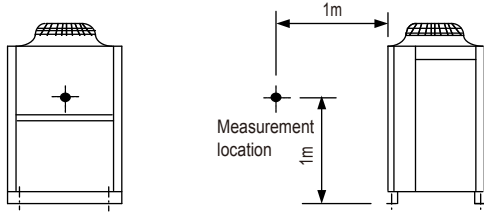

Sound level of PUHY-RP300YJM-B(-BS)

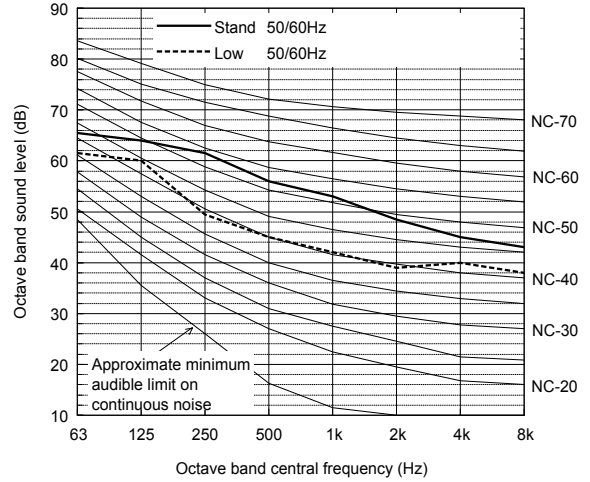

		63	125	250	500	1k	2k	4k	8k	dB(A)
Standard	50/60Hz	65.5	64.0	61.5	56.0	53.0	48.5	45.0	43.0	59.0
Low noise mode	50/60Hz	61.5	60.0	49.5	45.0	42.0	39.0	40.0	38.0	50.0

When Low noise mode is set, the A/C system's capacity is limited. The system could return to normal operation from Low noise mode automatically in the case that the operation condition is severe.

Sound level of PUHY-RP200YJM-B(-BS)

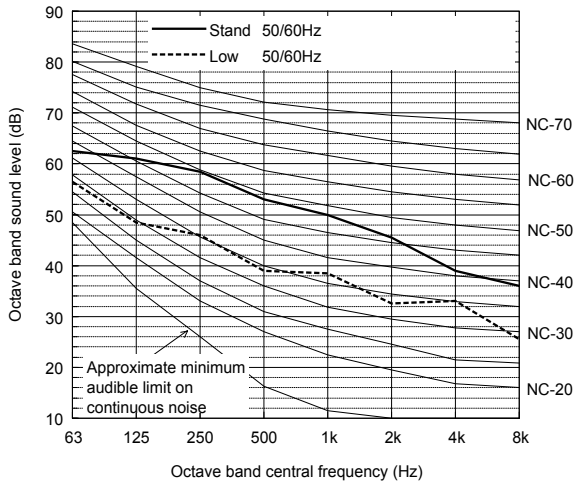

		63	125	250	500	1k	2k	4k	8k	dB(A)
Standard	50/60Hz	62.5	61.0	58.5	53.0	50.0	45.5	39.0	36.0	56.0
Low noise mode	50/60Hz	56.5	48.5	46.0	39.0	38.5	32.5	33.0	25.5	44.0

When Low noise mode is set, the A/C system's capacity is limited. The system could return to normal operation from Low noise mode automatically in the case that the operation condition is severe.

Sound level of PUHY-RP350YJM-B(-BS)

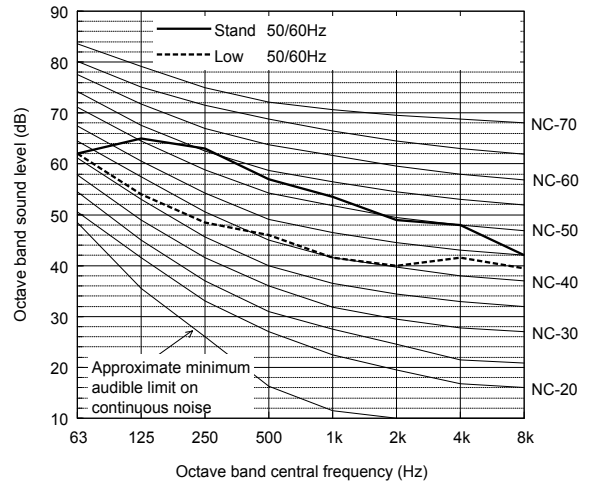

		63	125	250	500	1k	2k	4k	8k	dB(A)
Standard	50/60Hz	62.0	65.0	63.0	57.0	53.5	49.0	48.0	42.0	60.0
Low noise mode	50/60Hz	62.0	54.0	48.5	46.0	41.5	40.0	41.5	39.5	50.0

When Low noise mode is set, the A/C system's capacity is limited. The system could return to normal operation from Low noise mode automatically in the case that the operation condition is severe.

Sound level of PUHY-RP250YJM-B(-BS)

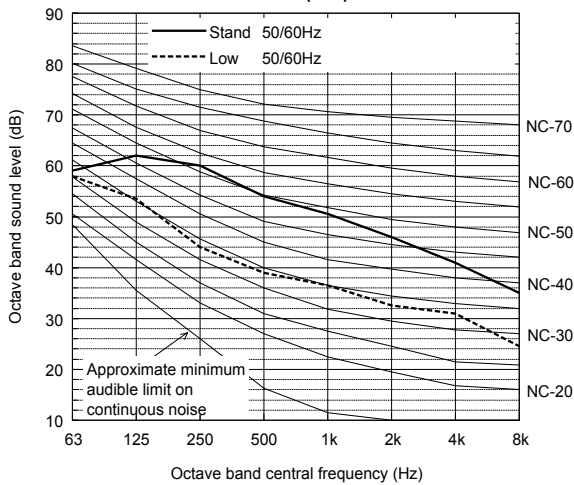

		63	125	250	500	1k	2k	4k	8k	dB(A)
Standard	50/60Hz	59.0	62.0	60.0	54.0	50.5	46.0	41.0	35.0	57.0
Low noise mode	50/60Hz	58.0	53.5	44.0	39.0	36.5	32.5	31.0	24.5	44.0

When Low noise mode is set, the A/C system's capacity is limited. The system could return to normal operation from Low noise mode automatically in the case that the operation condition is severe.

5. SOUND LEVELS

Measurement condition
PUHY-RP400, 450, 500, 550, 600, 650YSJM-B(-BS)

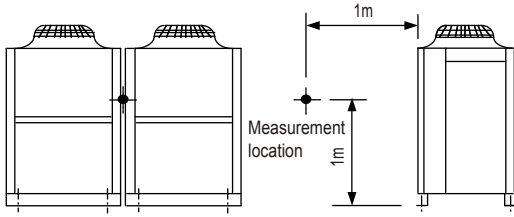

Sound level of PUHY-RP500YSJM-B(-BS)

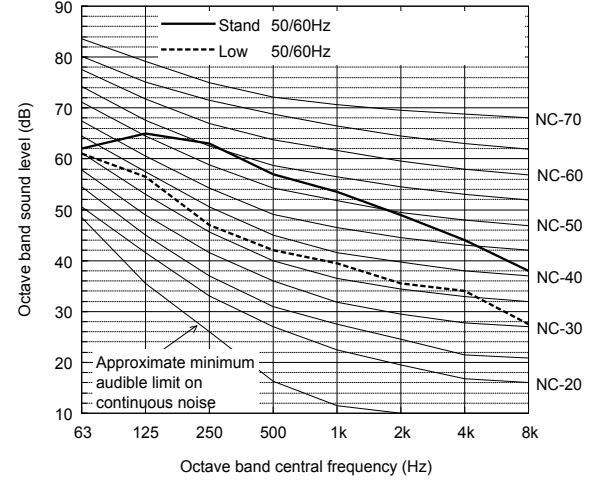

		63	125	250	500	1k	2k	4k	8k	dB(A)
Standard	50/60Hz	62.0	65.0	63.0	57.0	53.5	49.0	44.0	38.0	60.0
Low noise mode	50/60Hz	61.0	56.5	47.0	42.0	39.5	35.5	34.0	27.5	47.0

When Low noise mode is set, the A/C system's capacity is limited. The system could return to normal operation from Low noise mode automatically in the case that the operation condition is severe.

Sound level of PUHY-RP400YSJM-B(-BS)

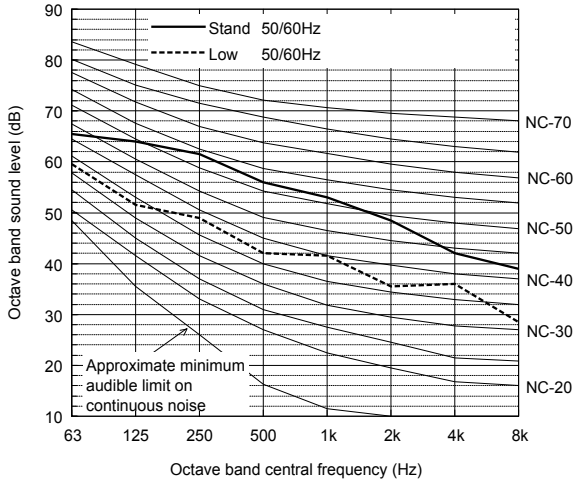

		63	125	250	500	1k	2k	4k	8k	dB(A)
Standard	50/60Hz	65.5	64.0	61.5	56.0	53.0	48.5	42.0	39.0	59.0
Low noise mode	50/60Hz	59.5	51.5	49.0	42.0	41.5	35.5	36.0	28.5	47.0

When Low noise mode is set, the A/C system's capacity is limited. The system could return to normal operation from Low noise mode automatically in the case that the operation condition is severe.

Sound level of PUHY-RP550YSJM-B(-BS)

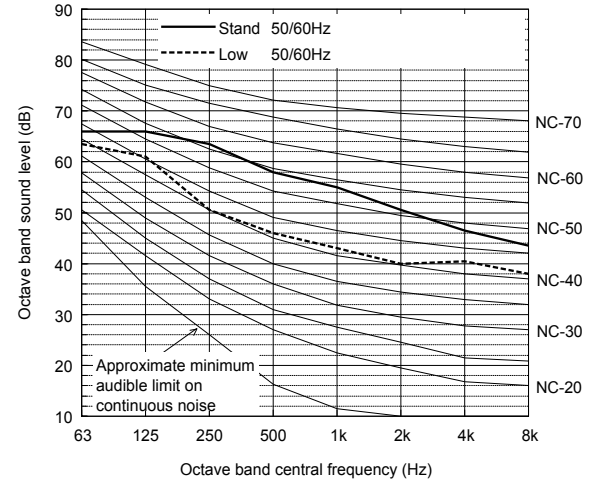

		63	125	250	500	1k	2k	4k	8k	dB(A)
Standard	50/60Hz	66.0	66.0	63.5	58.0	55.0	50.5	46.5	43.5	61.0
Low noise mode	50/60Hz	63.5	61.0	50.5	46.0	43.0	40.0	40.5	38.0	51.0

When Low noise mode is set, the A/C system's capacity is limited. The system could return to normal operation from Low noise mode automatically in the case that the operation condition is severe.

Sound level of PUHY-RP450YSJM-B(-BS)

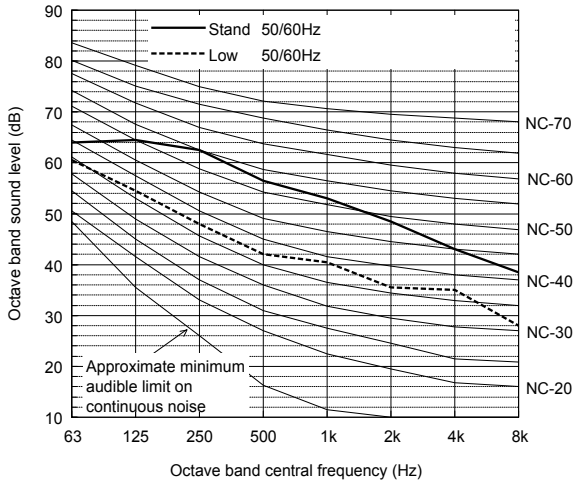

		63	125	250	500	1k	2k	4k	8k	dB(A)
Standard	50/60Hz	64.0	64.5	62.5	56.5	53.0	48.5	43.0	38.5	59.5
Low noise mode	50/60Hz	60.5	54.5	48.0	42.0	40.5	35.5	35.0	28.0	47.0

When Low noise mode is set, the A/C system's capacity is limited. The system could return to normal operation from Low noise mode automatically in the case that the operation condition is severe.

Sound level of PUHY-RP600YSJM-B(-BS)

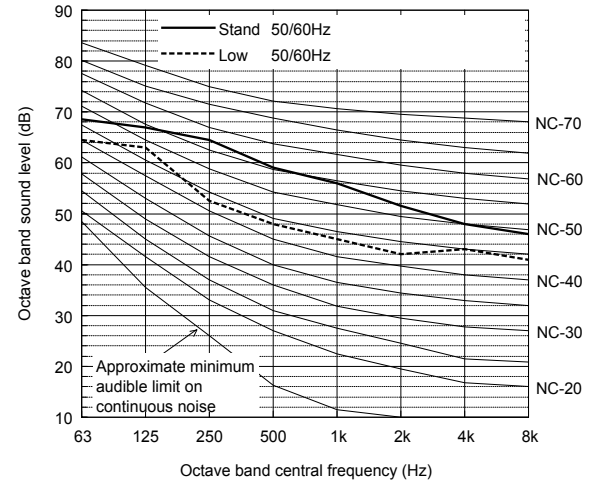

		63	125	250	500	1k	2k	4k	8k	dB(A)
Standard	50/60Hz	68.5	67.0	64.5	59.0	56.0	51.5	48.0	46.0	62.0
Low noise mode	50/60Hz	64.5	63.0	52.5	48.0	45.0	42.0	43.0	41.0	53.0

When Low noise mode is set, the A/C system's capacity is limited. The system could return to normal operation from Low noise mode automatically in the case that the operation condition is severe.

5. SOUND LEVELS

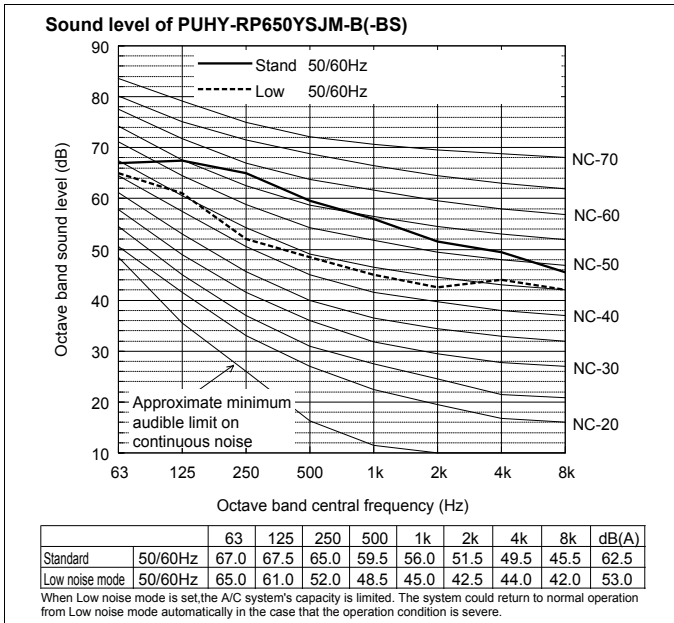

5. SOUND LEVELS

Measurement condition PUHY-RP700, 750, 800, 850, 900YSJM-B(-BS)

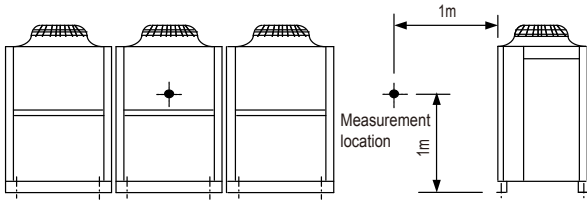

Sound level of PUHY-RP800YSJM-B(-BS)

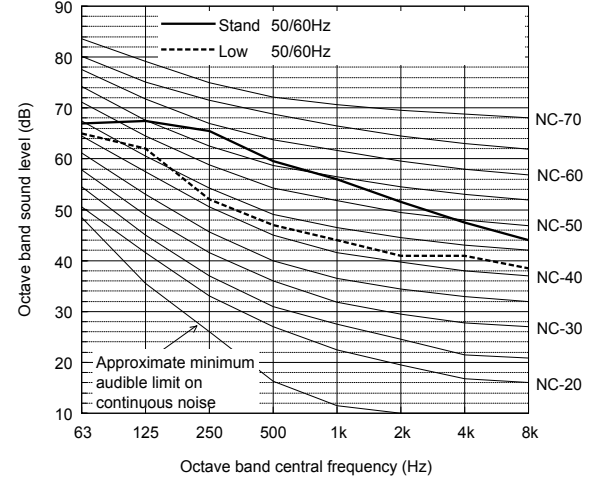

		63	125	250	500	1k	2k	4k	8k	dB(A)
Standard	50/60Hz	67.0	67.5	65.5	59.5	56.0	51.5	47.5	44.0	62.5
Low noise mode	50/60Hz	65.0	62.0	52.0	47.0	44.0	41.0	41.0	38.5	52.0

When Low noise mode is set, the A/C system's capacity is limited. The system could return to normal operation from Low noise mode automatically in the case that the operation condition is severe.

Sound level of PUHY-RP700YSJM-B(-BS)

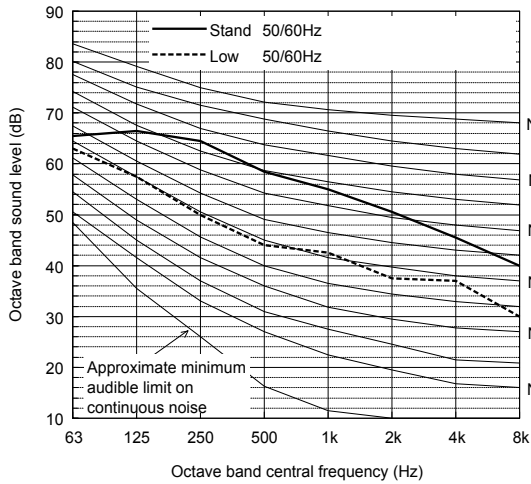

		63	125	250	500	1k	2k	4k	8k	dB(A)
Standard	50/60Hz	65.5	66.5	64.5	58.5	55.0	50.5	45.5	40.0	61.5
Low noise mode	50/60Hz	63.0	57.5	50.0	44.0	42.5	37.5	37.0	30.0	49.0

When Low noise mode is set, the A/C system's capacity is limited. The system could return to normal operation from Low noise mode automatically in the case that the operation condition is severe.

Sound level of PUHY-RP850YSJM-B(-BS)

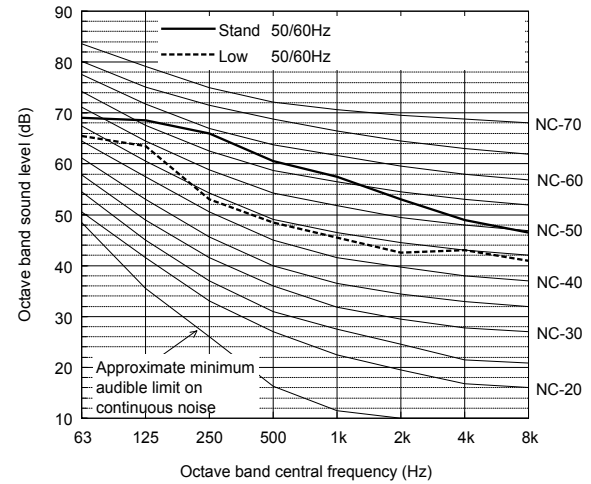

		63	125	250	500	1k	2k	4k	8k	dB(A)
Standard	50/60Hz	69.0	68.5	66.0	60.5	57.5	53.0	49.0	46.5	63.5
Low noise mode	50/60Hz	65.5	63.5	53.0	48.5	45.5	42.5	43.0	41.0	53.5

When Low noise mode is set, the A/C system's capacity is limited. The system could return to normal operation from Low noise mode automatically in the case that the operation condition is severe.

Sound level of PUHY-RP750YSJM-B(-BS)

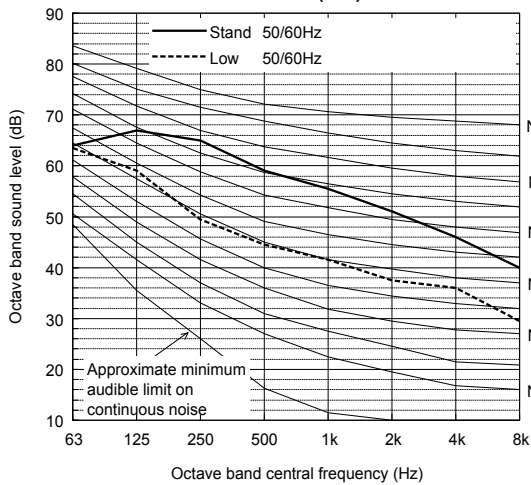

		63	125	250	500	1k	2k	4k	8k	dB(A)
Standard	50/60Hz	64.0	67.0	65.0	59.0	55.5	51.0	46.0	40.0	62.0
Low noise mode	50/60Hz	63.5	59.0	49.5	44.5	41.5	37.5	36.0	29.5	49.0

When Low noise mode is set, the A/C system's capacity is limited. The system could return to normal operation from Low noise mode automatically in the case that the operation condition is severe.

Sound level of PUHY-RP900YSJM-B(-BS)

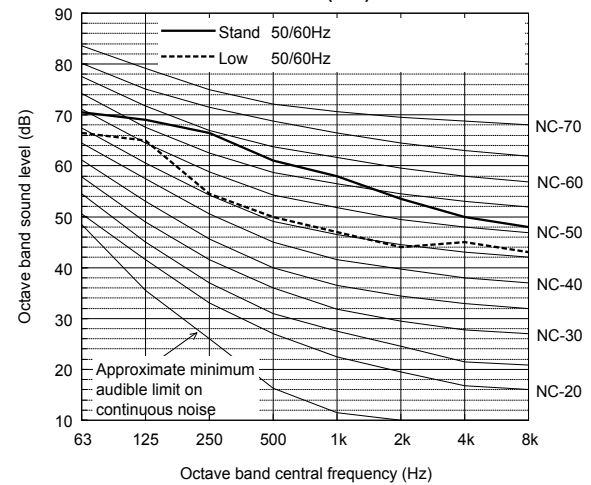

		63	125	250	500	1k	2k	4k	8k	dB(A)
Standard	50/60Hz	70.5	69.0	66.5	61.0	58.0	53.5	50.0	48.0	64.0
Low noise mode	50/60Hz	66.5	65.0	54.5	50.0	47.0	44.0	45.0	43.0	55.0

When Low noise mode is set, the A/C system's capacity is limited. The system could return to normal operation from Low noise mode automatically in the case that the operation condition is severe.

6. CAPACITY TABLES

6-1. Correction by temperature

CITY MULTI could have various capacities at different designing temperatures. Using the nominal cooling/heating capacity values and the ratios below, the capacity can be found for various temperatures.

PUHY-		RP200YJM-B	RP250YJM-B
Nominal Cooling Capacity	kW	22.4	28.0
	BTU/h	76,400	95,500
Input	kW	5.68	7.62

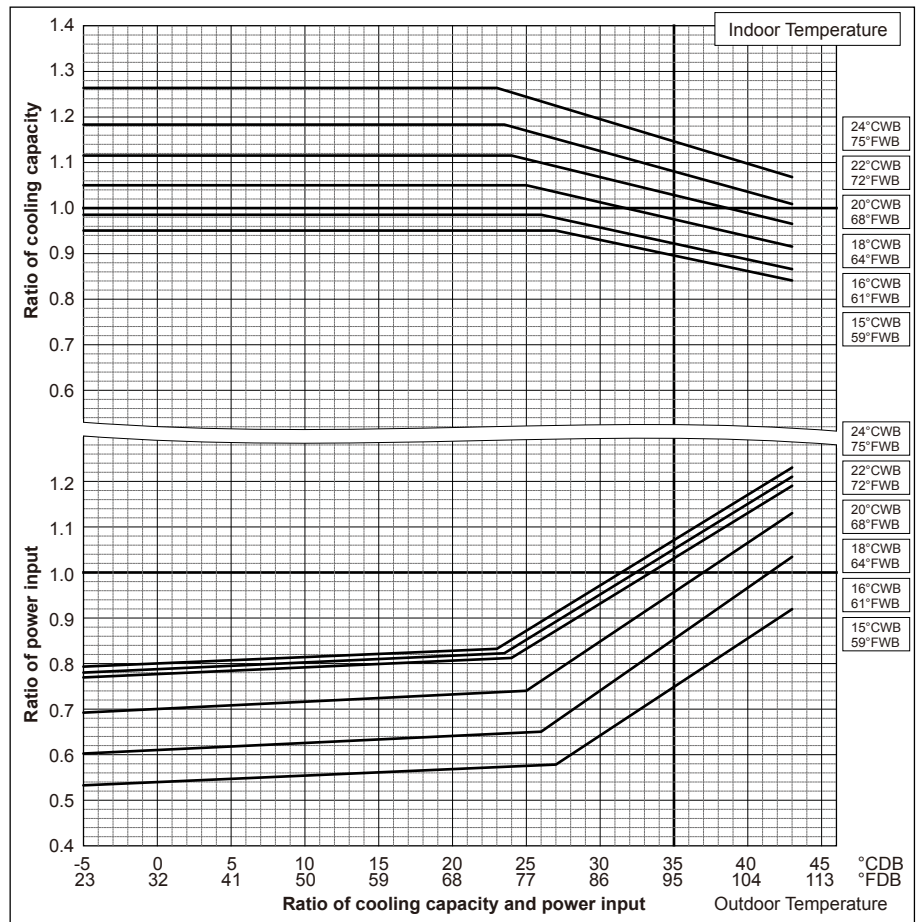

PUHY-		RP200YJM-B	RP250YJM-B
Nominal Heating Capacity	kW	25.0	31.5
	BTU/h	85,300	107,500
Input	kW	5.69	7.22

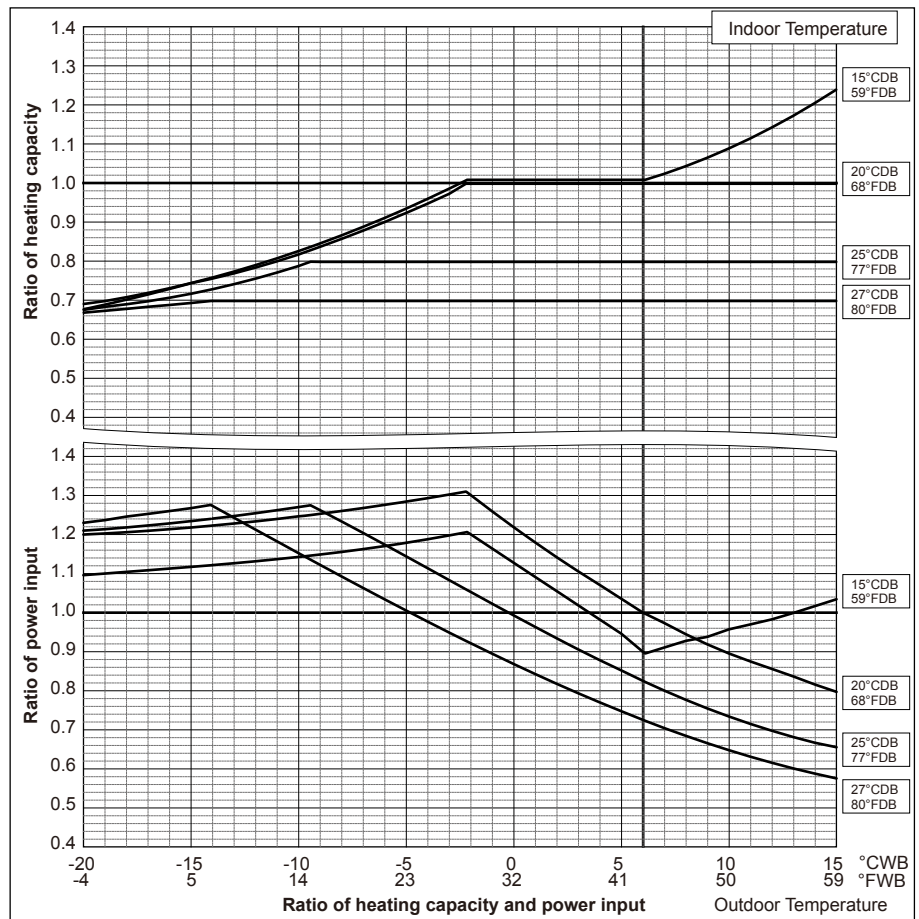

6. CAPACITY TABLES

PUHY-		RP300YJM-B	RP350YJM-B
Nominal Cooling Capacity	kW	33.5	40.0
	BTU/h	114,300	136,500
Input	kW	8.98	11.79

PUHY-		RP400YSJM-B
Nominal Cooling Capacity	kW	45.0
	BTU/h	153,500
Input	kW	11.87

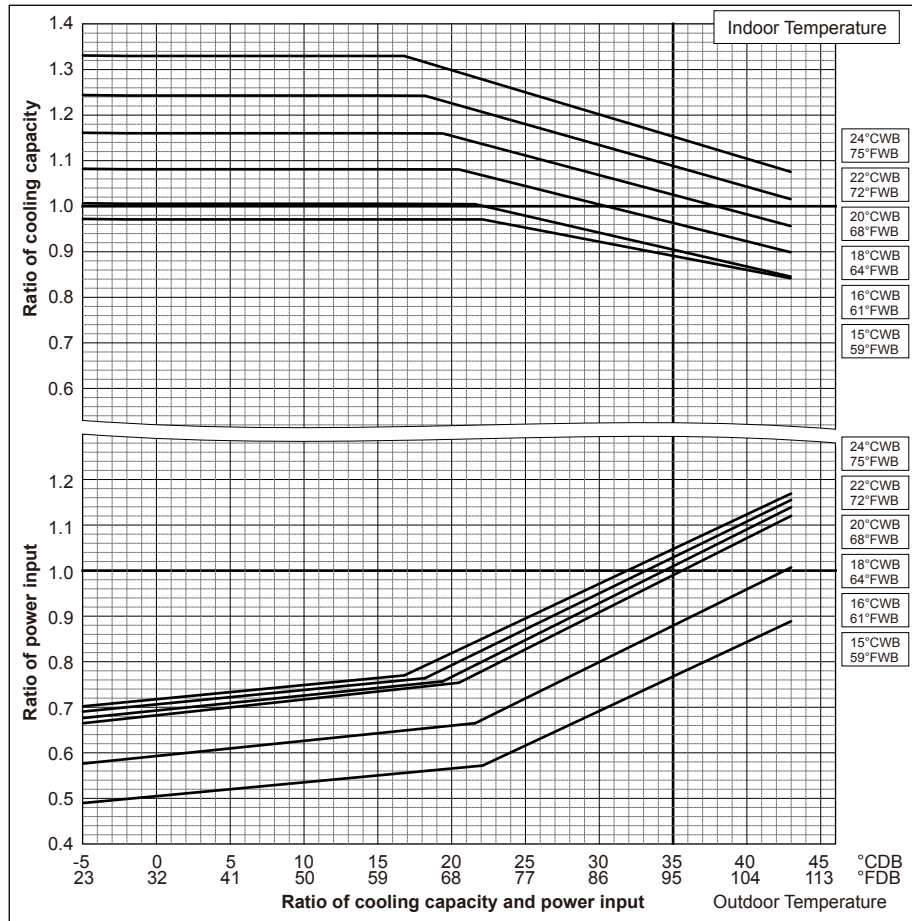

PUHY-		RP300YJM-B	RP350YJM-B
Nominal Heating Capacity	kW	37.5	45.0
	BTU/h	128,000	153,500
Input	kW	9.42	12.60

PUHY-		RP400YSJM-B
Nominal Heating Capacity	kW	50
	BTU/h	170,600
Input	kW	11.38

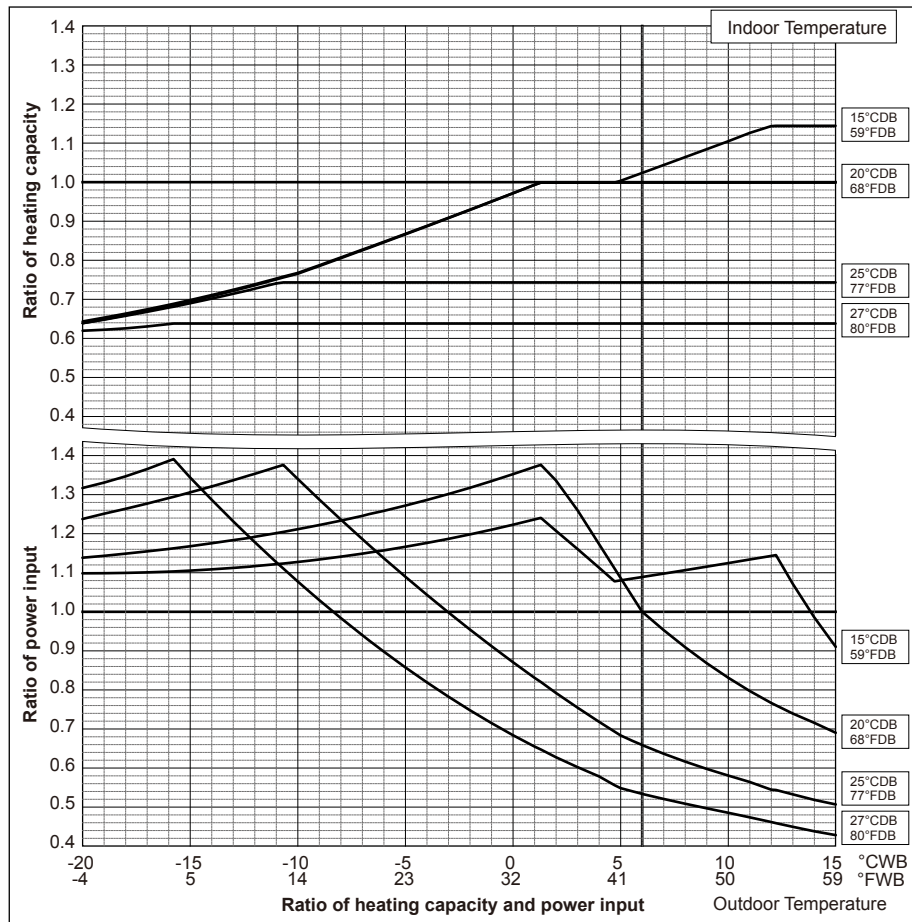

6. CAPACITY TABLES

PUHY-		RP450YSJM-B	RP500YSJM-B
Nominal Cooling Capacity	kW	50.0	56.0
	BTU/h	170,600	191,100
Input	kW	13.77	15.68

PUHY-		RP550YSJM-B	P600YSJM-B
Nominal Cooling Capacity	kW	63.0	69.0
	BTU/h	215,000	235,400
Input	kW	17.50	18.59

PUHY-		RP650YSJM-B
Nominal Cooling Capacity	kW	73.0
	BTU/h	249,100
Input	kW	21.09

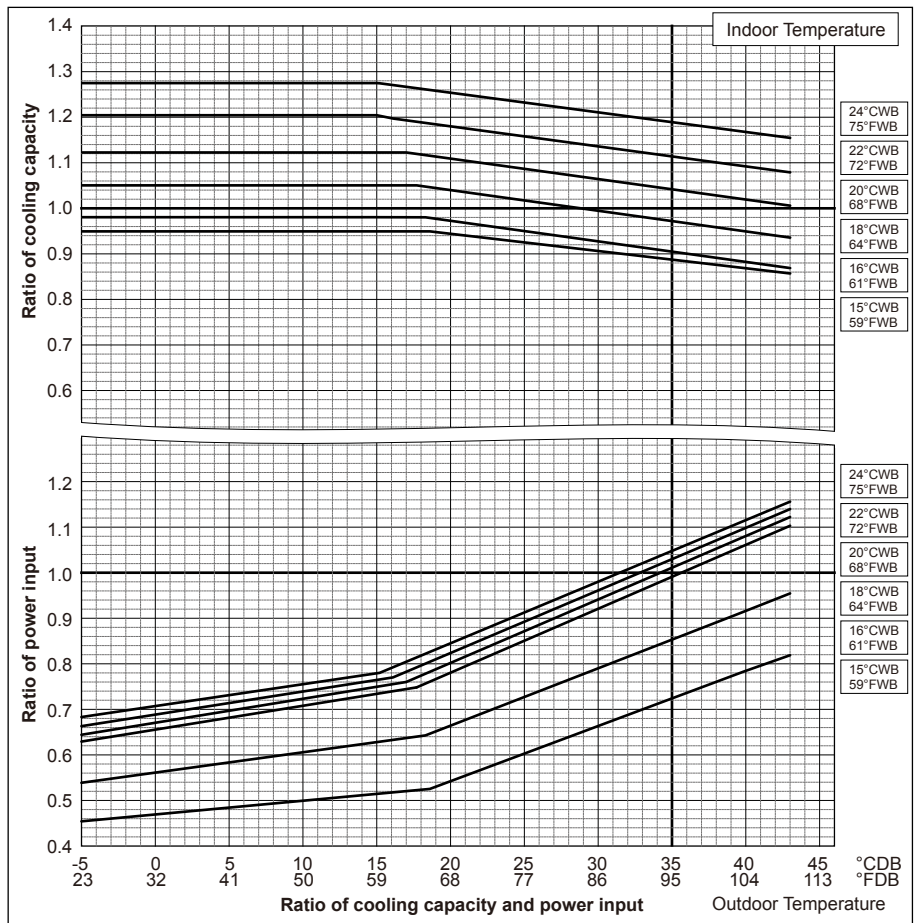

PUHY-		RP450YSJM-B	RP500YSJM-B
Nominal Heating Capacity	kW	56.0	63.0
	BTU/h	191,100	215,000
Input	kW	12.81	14.44

PUHY-		RP550YSJM-B	RP600YSJM-B
Nominal Heating Capacity	kW	69.0	76.5
	BTU/h	235,400	261,000
Input	kW	16.62	19.22

PUHY-		RP650YSJM-B
Nominal Heating Capacity	kW	81.5
	BTU/h	278,100
Input	kW	21.73

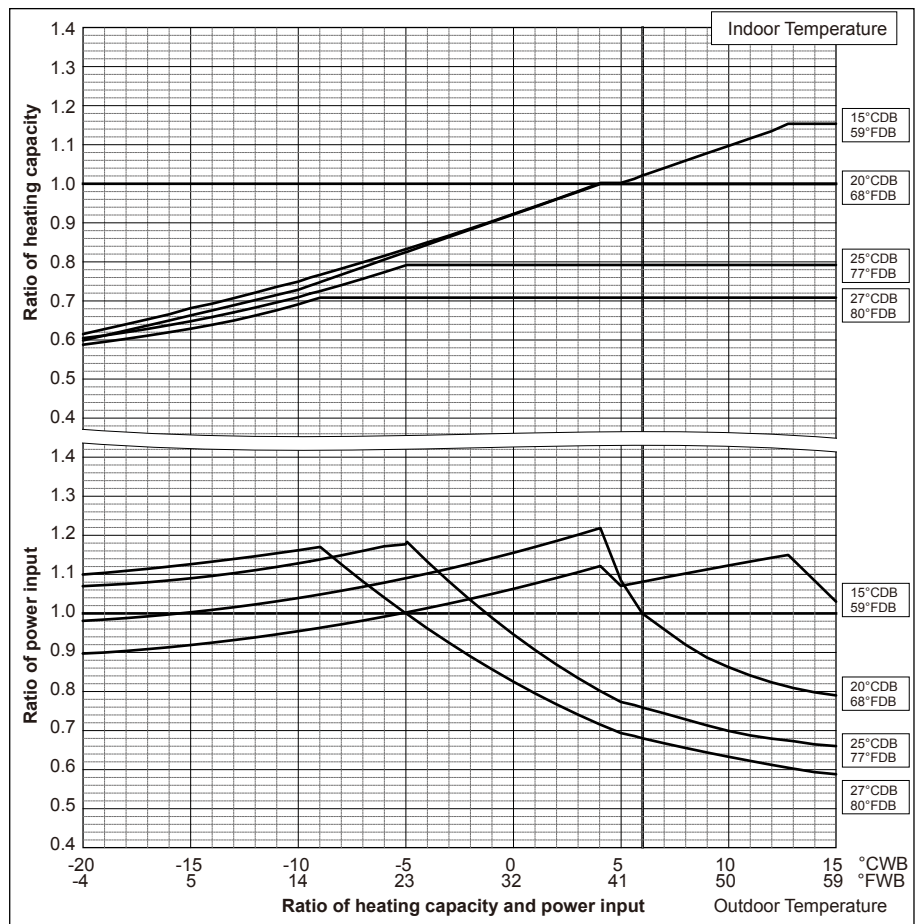

6. CAPACITY TABLES

PUHY-		RP700YSJM-B	PR750YSJM-B
Nominal Cooling Capacity	kW	80.0	85.0
	BTU/h	273,000	290,000
Input	kW	22.22	24.14

PUHY-		RP800YSJM-B
Nominal Cooling Capacity	kW	90.0
	BTU/h	307,100
Input	kW	25.49

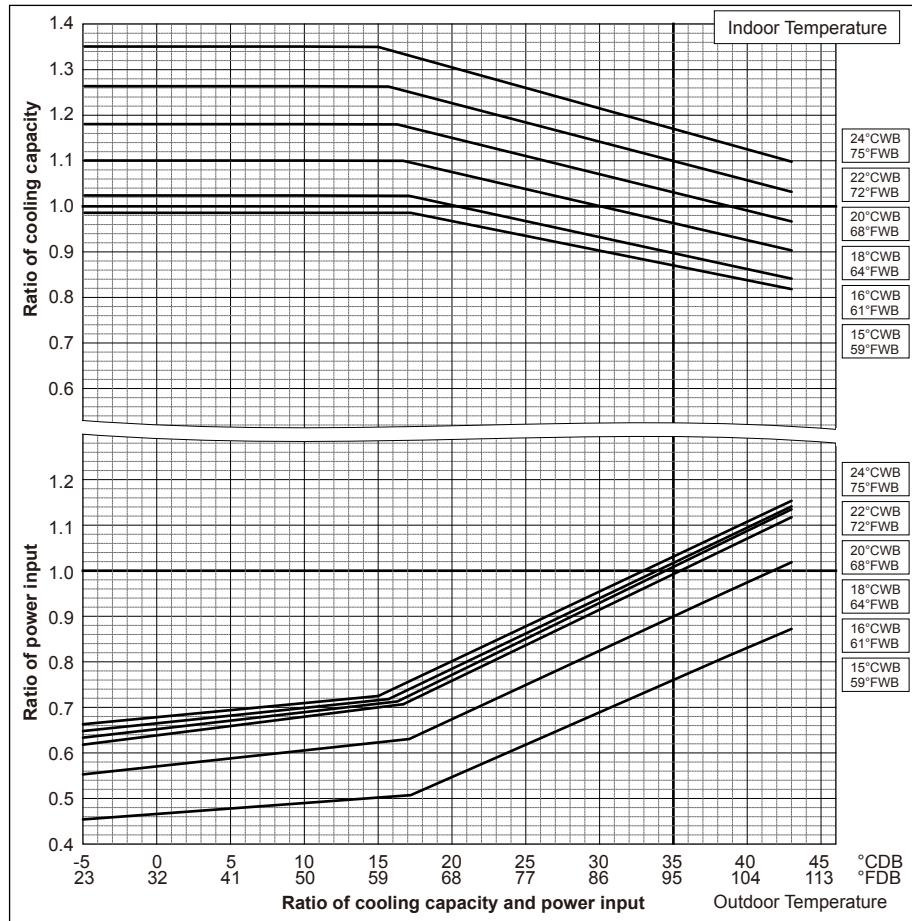

PUHY-		RP700YSJM-B	PR750YSJM-B
Nominal Heating Capacity	kW	88.0	95.0
	BTU/h	300,300	324,100
Input	kW	20.13	21.78

PUHY-		RP800YSJM-B
Nominal Heating Capacity	kW	100.0
	BTU/h	341,200
Input	kW	23.75

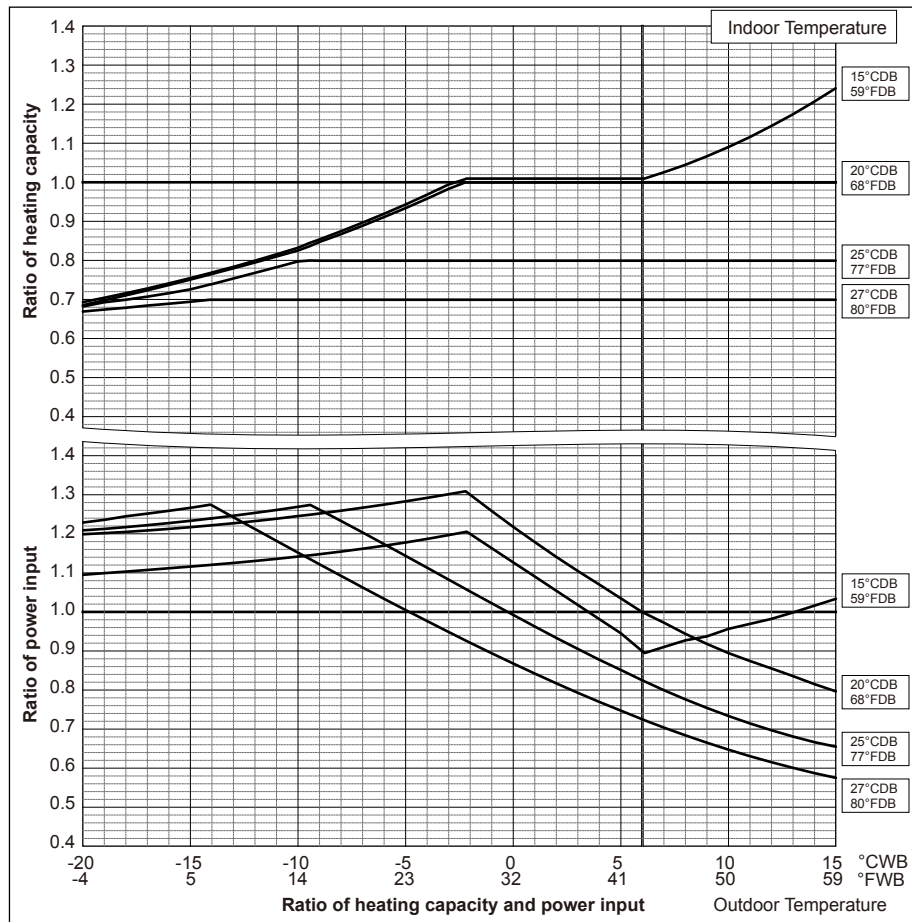

6. CAPACITY TABLES

PUHY-		RP850YSJM-B	RP900YSJM-B
Nominal Cooling Capacity	kW	96.0	101.0
	BTU/h	327,600	344,600
Input	kW	27.11	28.29

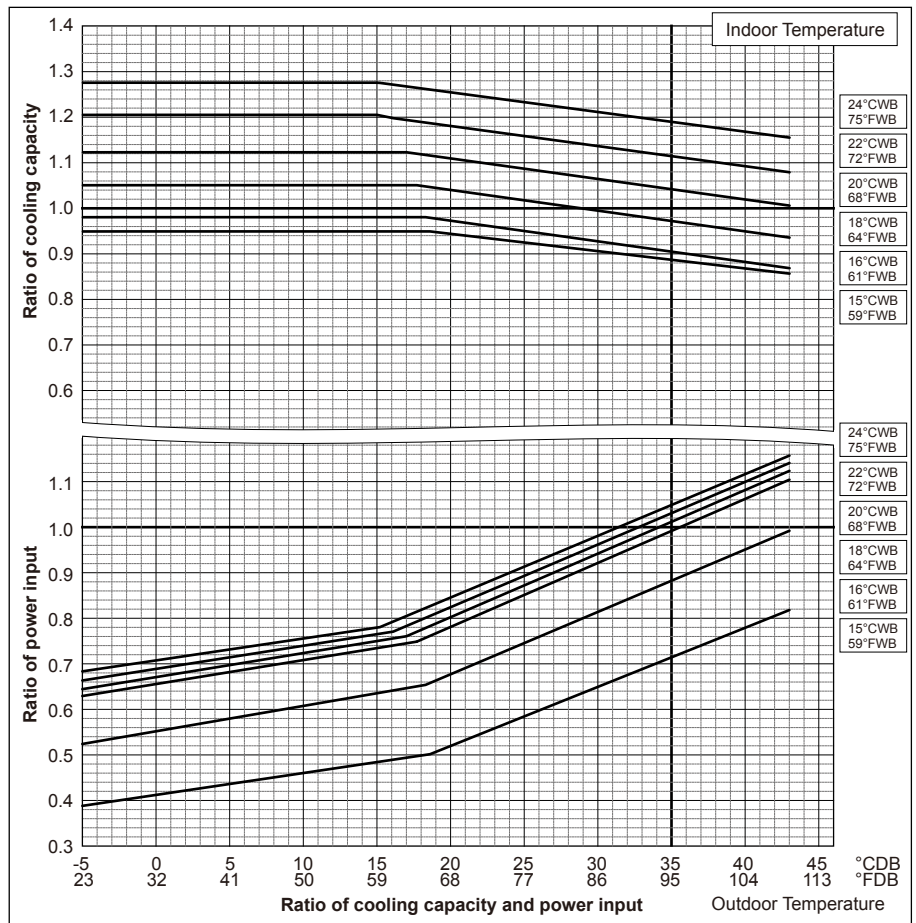

PUHY-		RP850YSJM-B	RP900YSJM-B
Nominal Heating Capacity	kW	108.0	113.0
	BTU/h	368,500	385,600
Input	kW	26.47	28.39

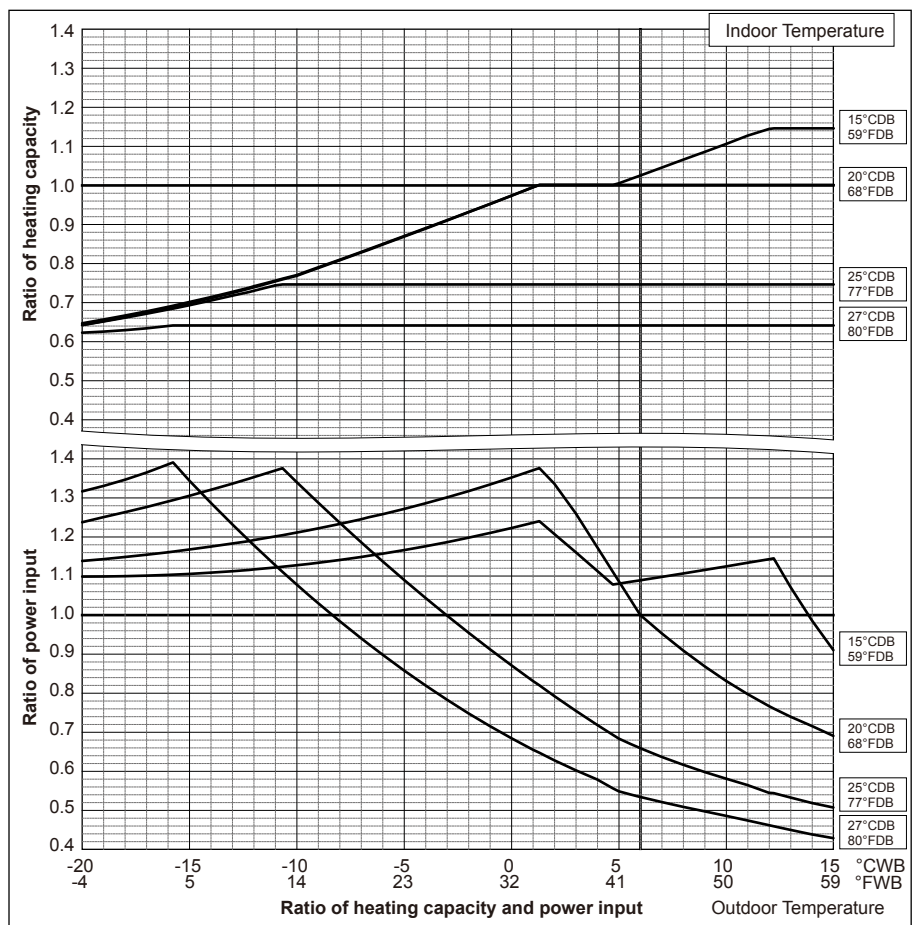

6. CAPACITY TABLES

Correction by temperature (COP Priority Mode)

CITY MULTI could have various capacities at different designing temperatures. Using the nominal cooling/heating capacity values and the ratios below, the capacity can be found for various temperatures.

To select high heating performance mode, DipSW 3-7 must be set to OFF.

PUHY-		RP200YJM-B	RP250YJM-B
Nominal Cooling Capacity	kW	22.4	28.0
	BTU/h	76,400	95,500
Input	kW	5.68	7.62

(There is no difference in cooling performance between Standard Mode and COP Priority Mode.)

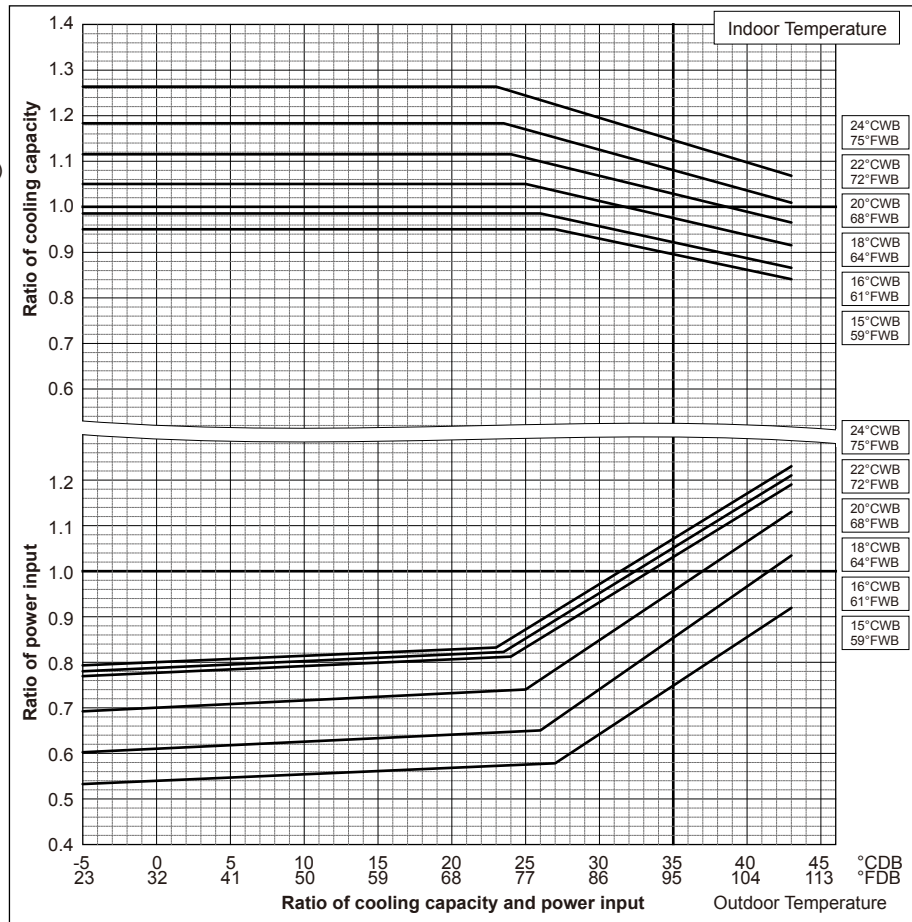

PUHY-		RP200YJM-B	RP250YJM-B
Nominal Heating Capacity	kW	25.0	31.5
	BTU/h	85,300	107,500
Input	kW	5.69	7.22

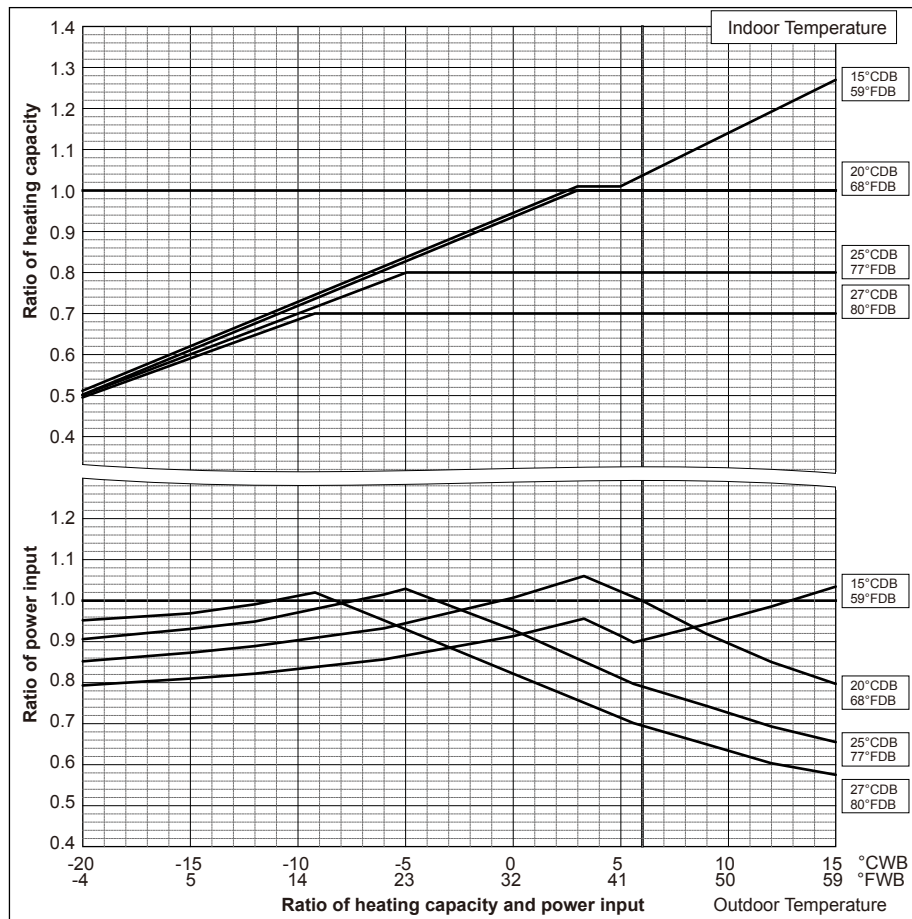

6. CAPACITY TABLES

PUHY-		RP300YJM-B	RP350YJM-B
Nominal Cooling Capacity	kW	33.5	40.0
	BTU/h	114,300	136,500
Input	kW	8.98	11.79

PUHY-		RP400YSJM-B
Nominal Cooling Capacity	kW	45.0
	BTU/h	153,500
Input	kW	11.87

(There is no difference in cooling performance between Standard Mode and COP Priority Mode.)

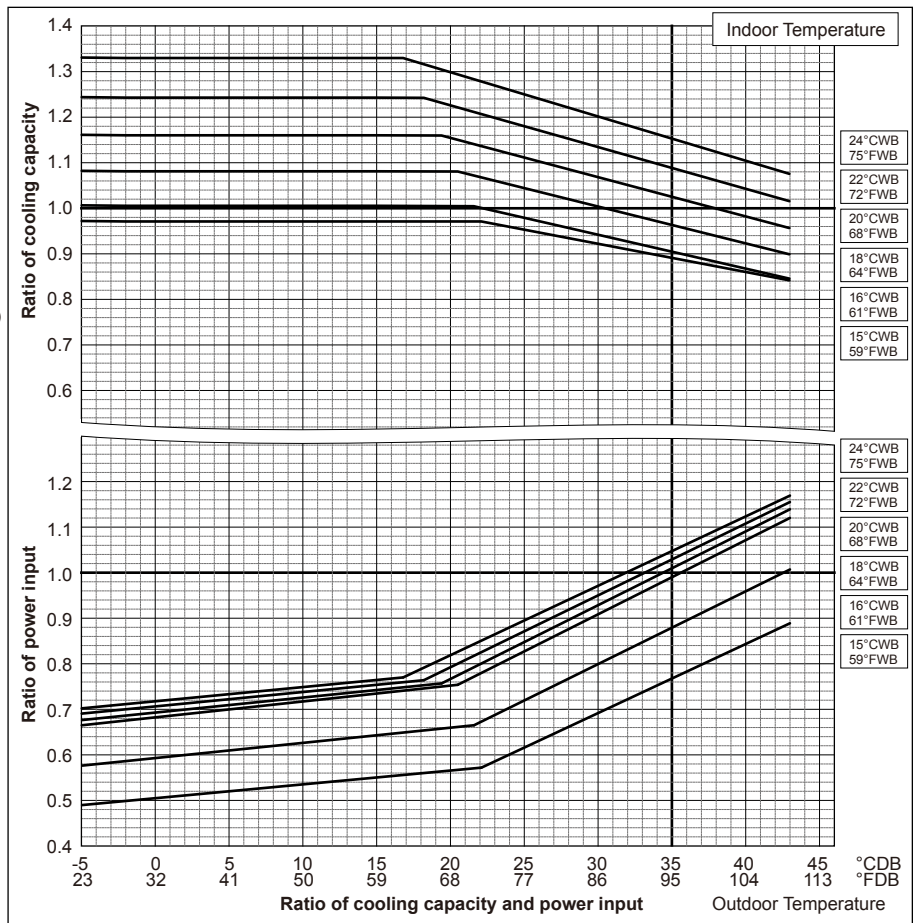

PUHY-		RP300YJM-B	RP350YJM-B
Nominal Heating Capacity	kW	37.5	45.0
	BTU/h	128,000	153,500
Input	kW	9.42	12.60

PUHY-		RP400YSJM-B
Nominal Heating Capacity	kW	50
	BTU/h	170,600
Input	kW	11.38

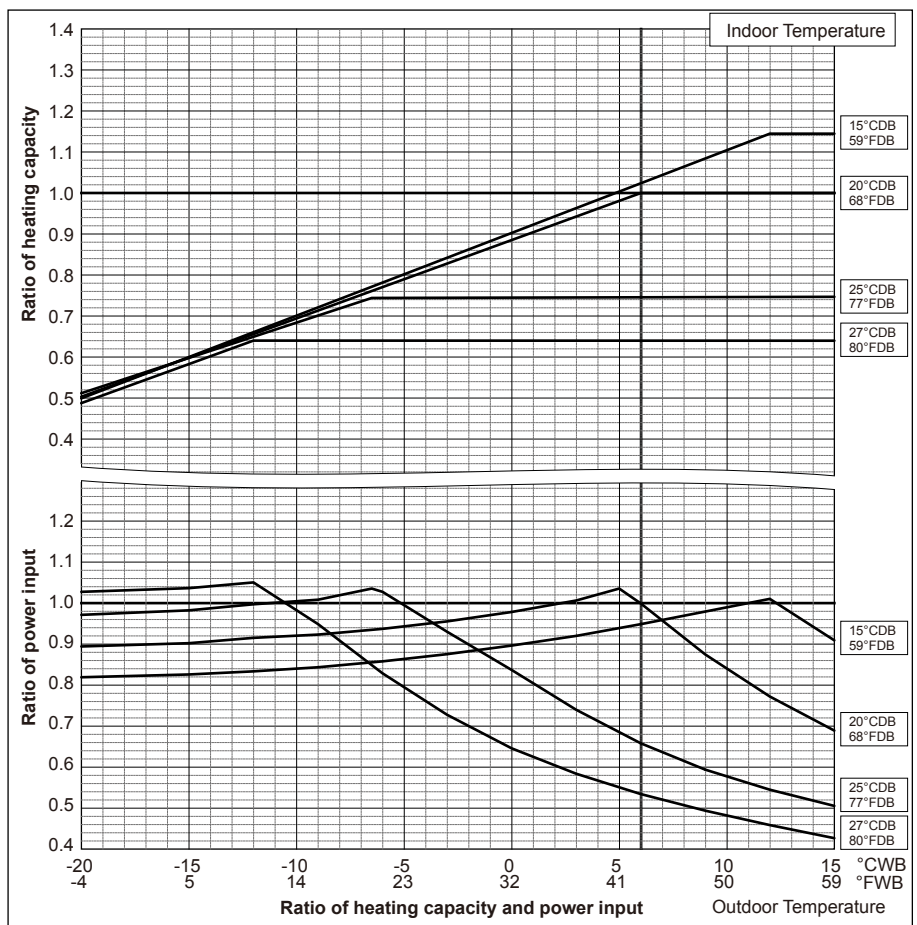

6. CAPACITY TABLES

PUHY-		RP450YSJM-B	RP500YSJM-B
Nominal Cooling Capacity	kW	50.0	56.0
	BTU/h	170,600	191,100
Input	kW	13.77	15.68

PUHY-		RP550YSJM-B	P600YSJM-B
Nominal Cooling Capacity	kW	63.0	69.0
	BTU/h	215,000	235,400
Input	kW	17.50	18.59

PUHY-		RP650YSJM-B
Nominal Cooling Capacity	kW	73.0
	BTU/h	249,100
Input	kW	21.09

(There is no difference in cooling performance between Standard Mode and COP Priority Mode.)

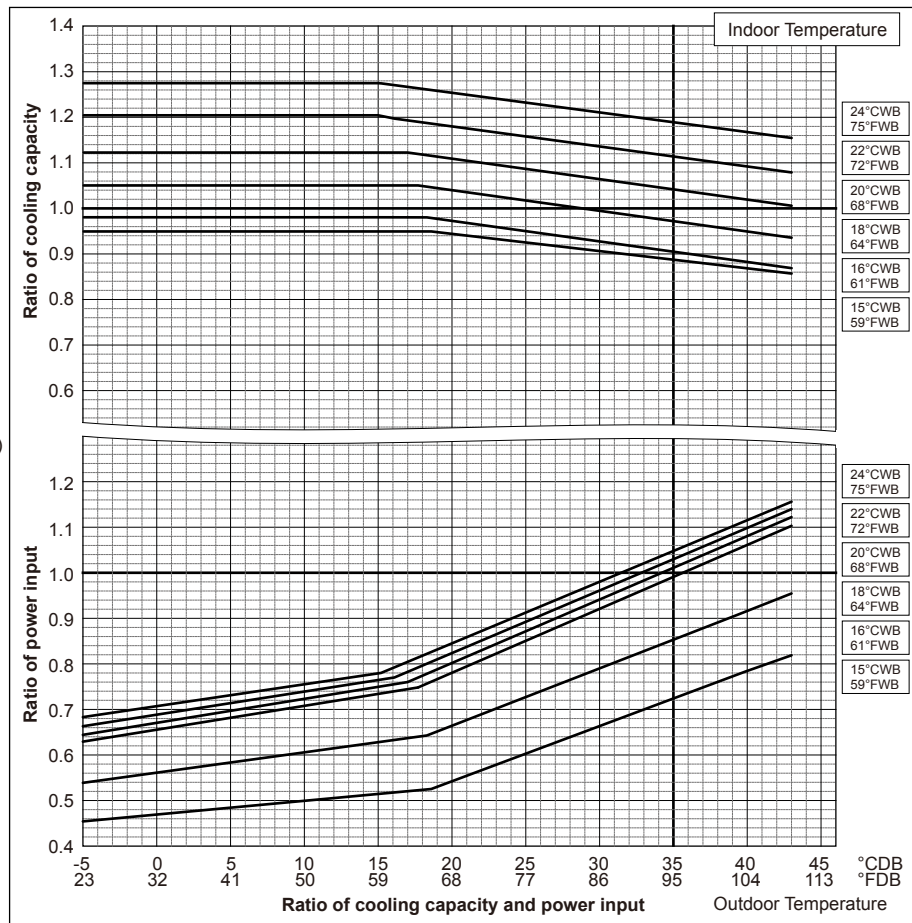

PUHY-		RP450YSJM-B	RP500YSJM-B
Nominal Heating Capacity	kW	56.0	63.0
	BTU/h	191,100	215,000
Input	kW	12.81	14.44

PUHY-		RP550YSJM-B	RP600YSJM-B
Nominal Heating Capacity	kW	69.0	76.5
	BTU/h	235,400	261,000
Input	kW	16.62	19.22

PUHY-		RP650YSJM-B
Nominal Heating Capacity	kW	81.5
	BTU/h	278,100
Input	kW	21.73

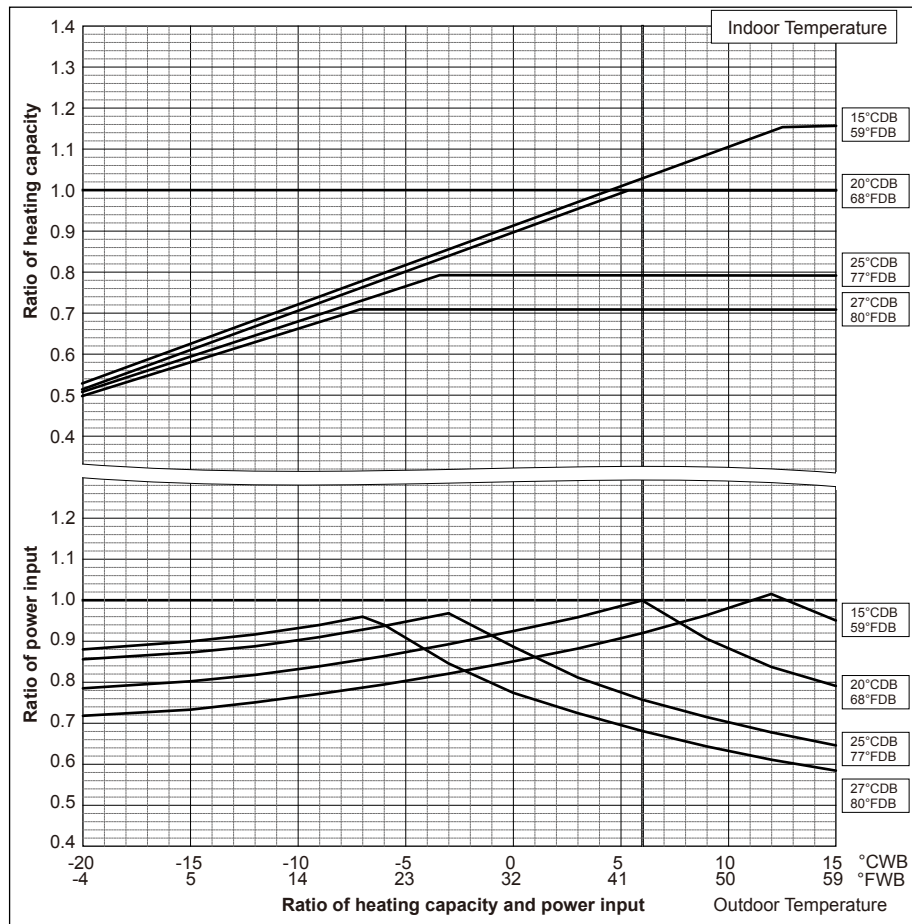

6. CAPACITY TABLES

PUHY-		RP700YSJM-B	RP750YSJM-B
Nominal Cooling Capacity	kW	80.0	85.0
	BTU/h	273,000	290,000
Input	kW	22.22	24.14

PUHY-		RP800YSJM-B
Nominal Cooling Capacity	kW	90.0
	BTU/h	307,100
Input	kW	25.49

(There is no difference in cooling performance between Standard Mode and COP Priority Mode.)

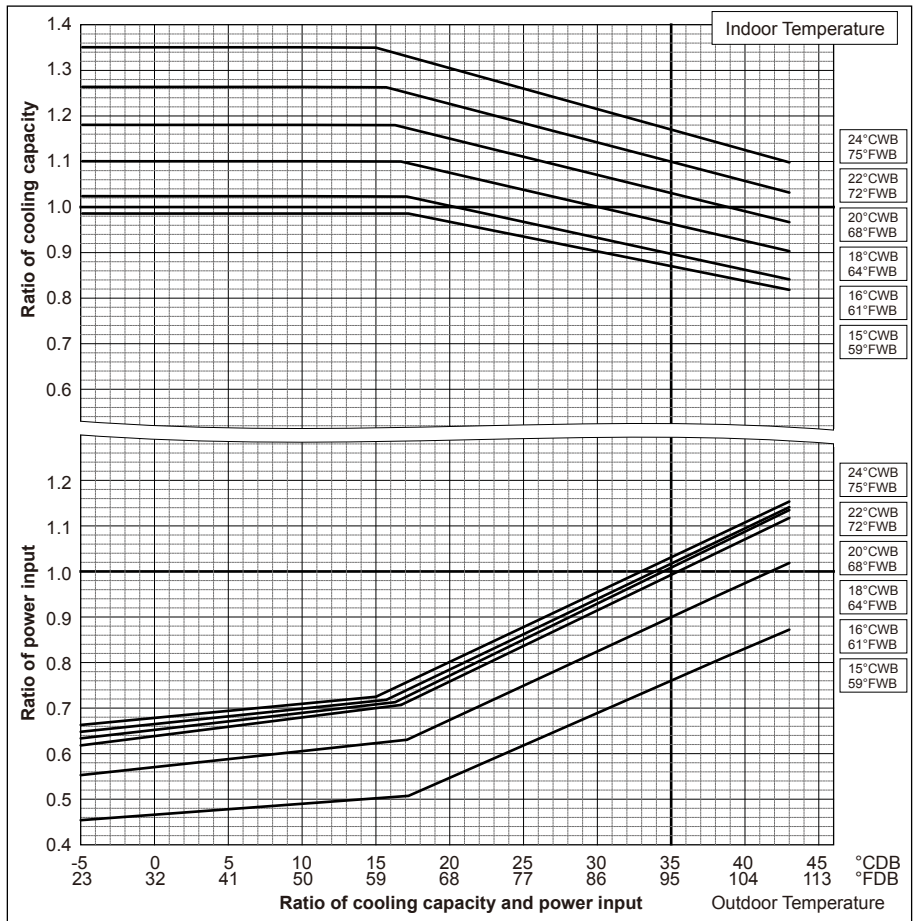

PUHY-		RP700YSJM-B	RP750YSJM-B
Nominal Heating Capacity	kW	88.0	95.0
	BTU/h	300,300	324,100
Input	kW	20.13	21.78

PUHY-		RP800YSJM-B
Nominal Heating Capacity	kW	100.0
	BTU/h	341,200
Input	kW	23.75

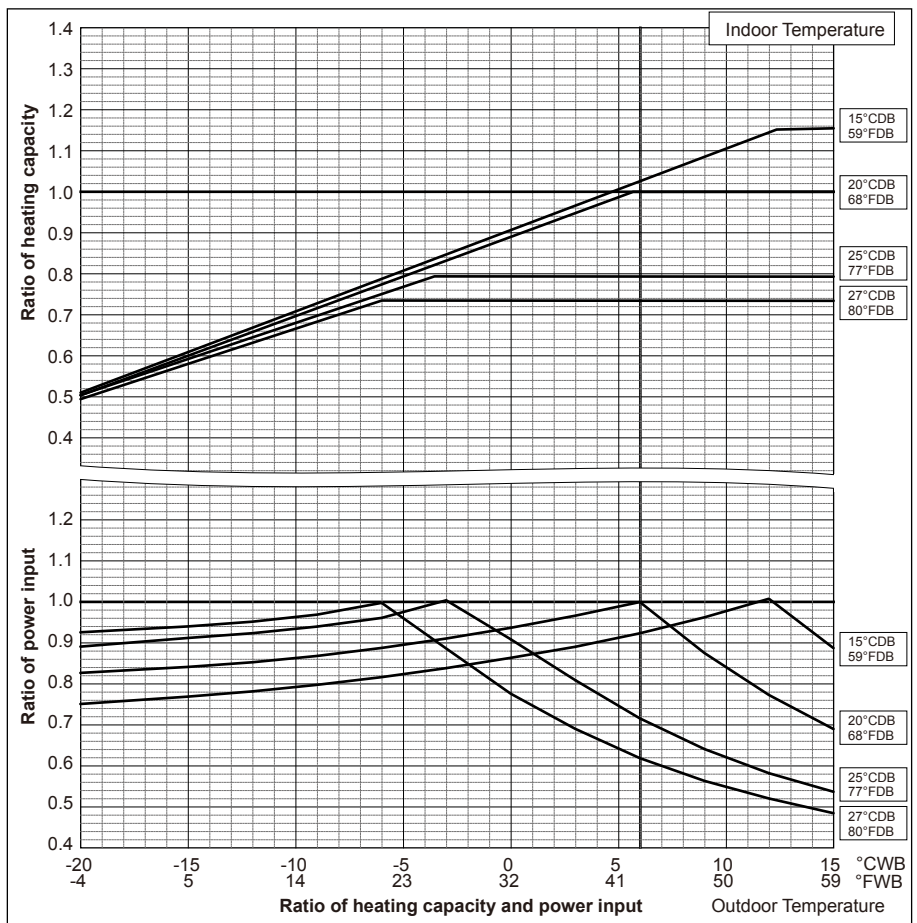

6. CAPACITY TABLES

PUHY-		RP850YSJM-B	RP900YSJM-B
Nominal Cooling Capacity	kW	96.0	101.0
	BTU/h	327,600	344,600
Input	kW	27.11	28.29

(There is no difference in cooling performance between Standard Mode and COP Priority Mode.)

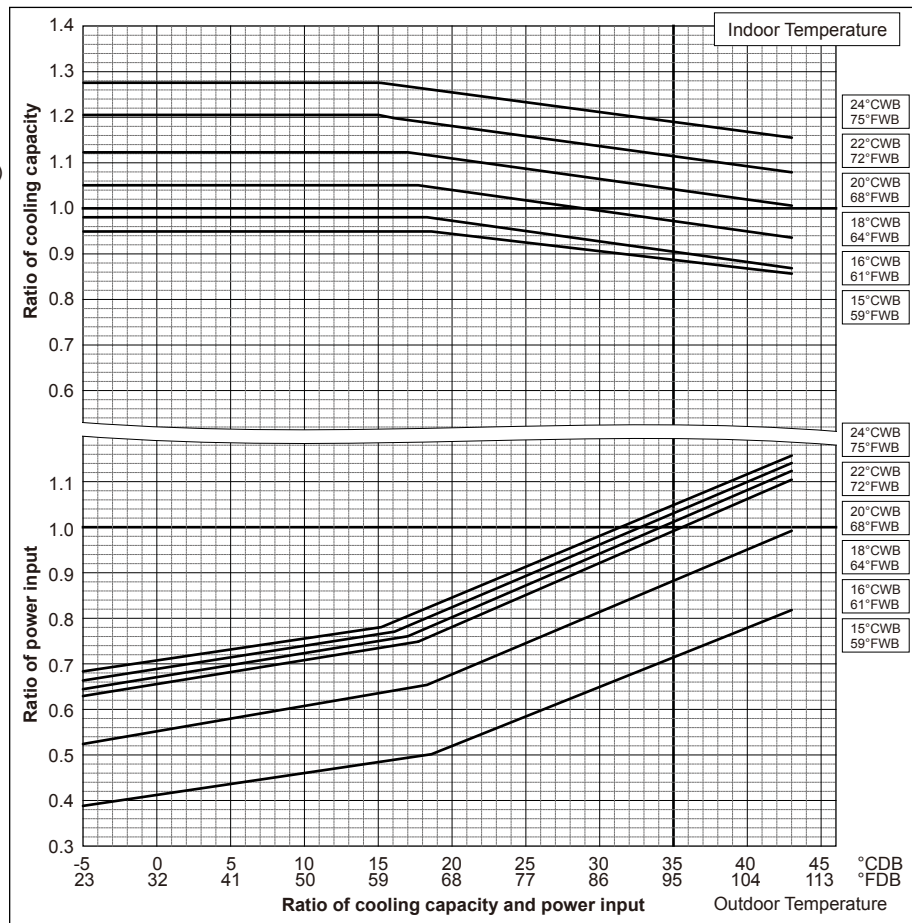

PUHY-		RP850YSJM-B	RP900YSJM-B
Nominal Heating Capacity	kW	108.0	113.0
	BTU/h	368,500	385,600
Input	kW	26.47	28.39

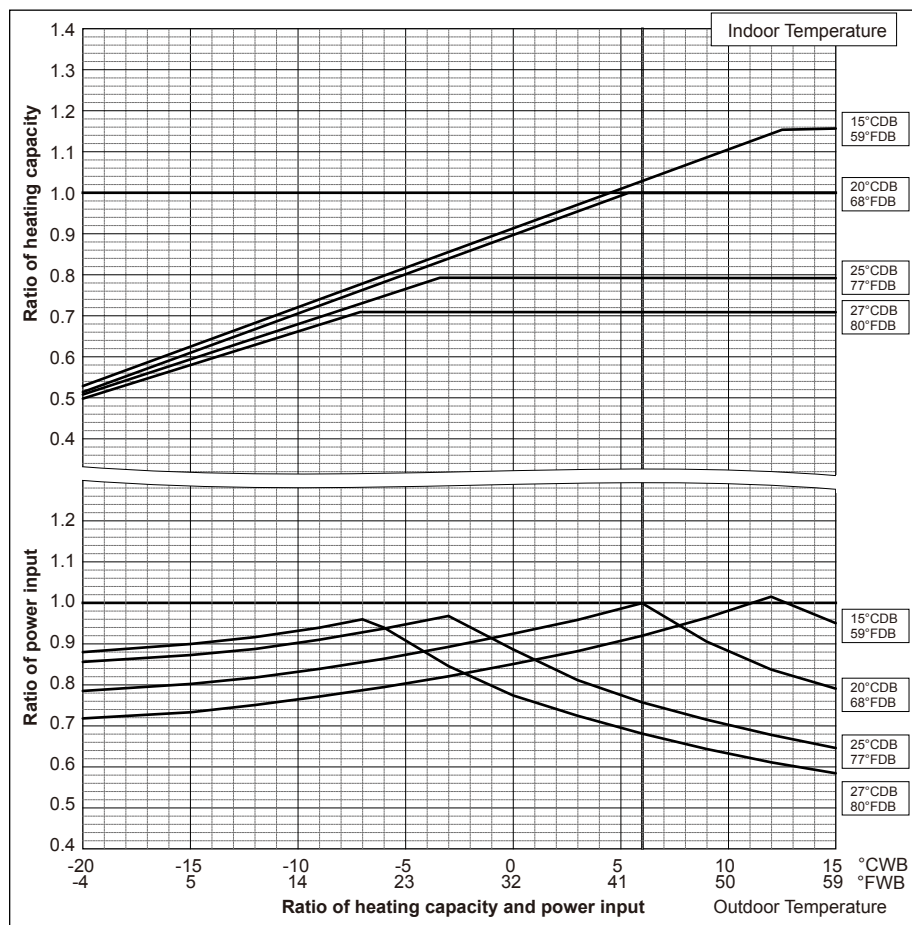

6. CAPACITY TABLES

Correction by temperature (Connection with PWFY-P100/200VM-E-AU (HEX unit))

PUHY-		RP200YJM-B	RP250YJM-B
Nominal Cooling Capacity	kW	22.4	28.0
	BTU/h	76,400	95,500
Input	kW	5.68	7.62

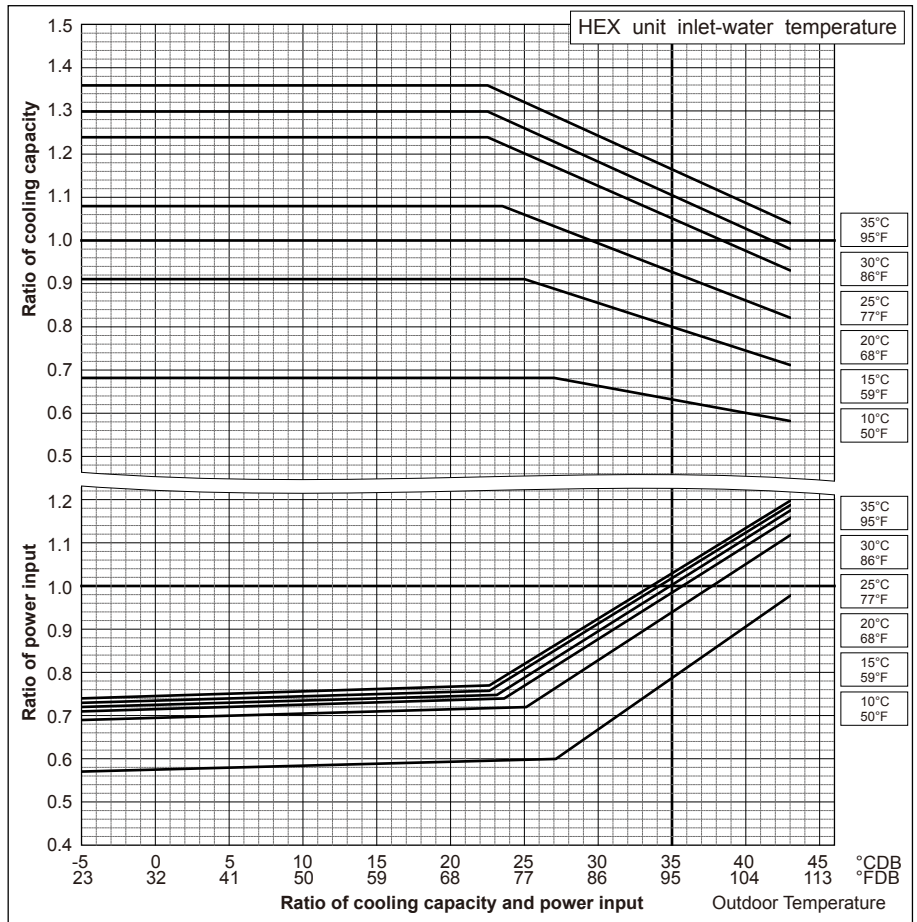

PUHY-		RP200YJM-B	RP250YJM-B
Nominal Heating Capacity	kW	25.0	31.5
	BTU/h	85,300	107,500
Input	kW	5.69	7.22

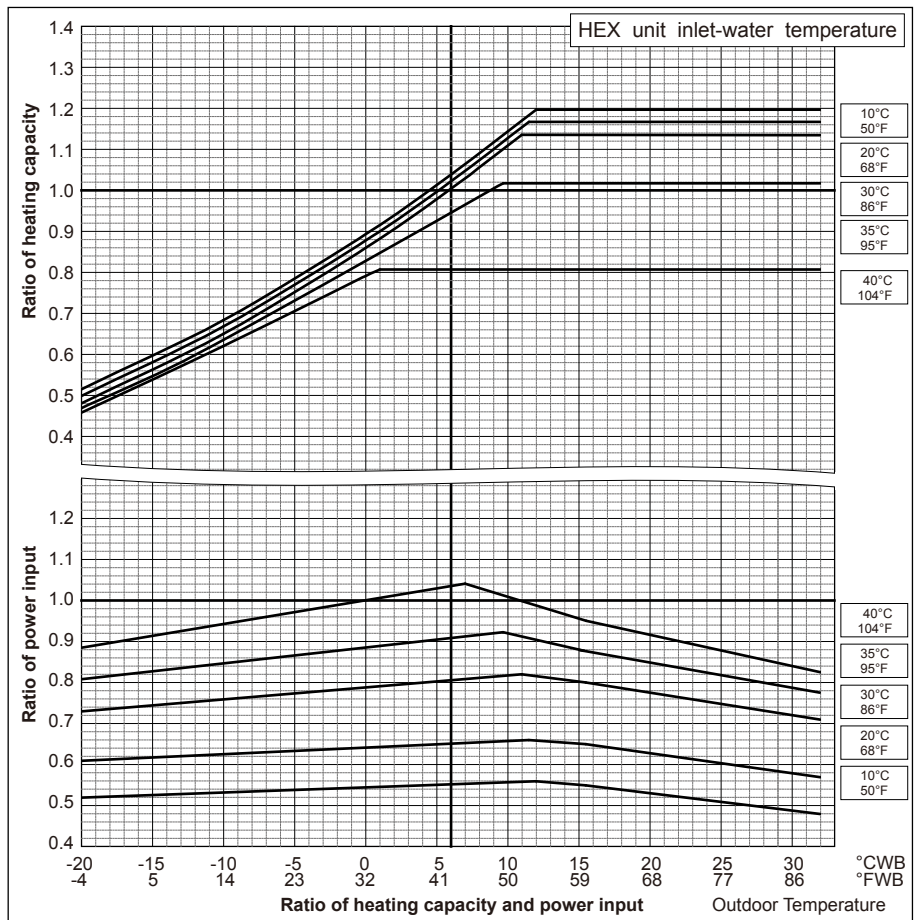

6. CAPACITY TABLES

PUHY-		RP300YJM-B	RP350YJM-B
Nominal Cooling Capacity	kW	33.5	40.0
	BTU/h	114,300	136,500
Input	kW	8.98	11.79

PUHY-		RP400YSJM-B
Nominal Cooling Capacity	kW	45.0
	BTU/h	153,500
Input	kW	11.87

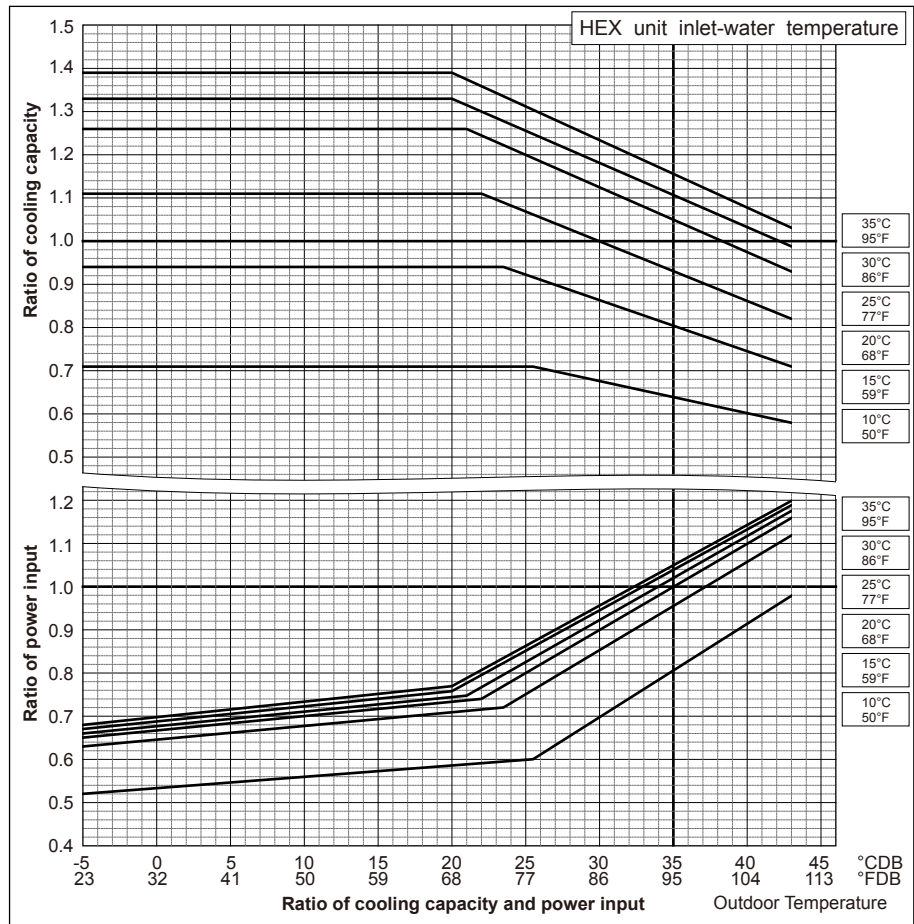

PUHY-		RP300YJM-B	RP350YJM-B
Nominal Heating Capacity	kW	37.5	45.0
	BTU/h	128,000	153,500
Input	kW	9.42	12.60

PUHY-		RP400YSJM-B
Nominal Heating Capacity	kW	50
	BTU/h	170,600
Input	kW	11.38

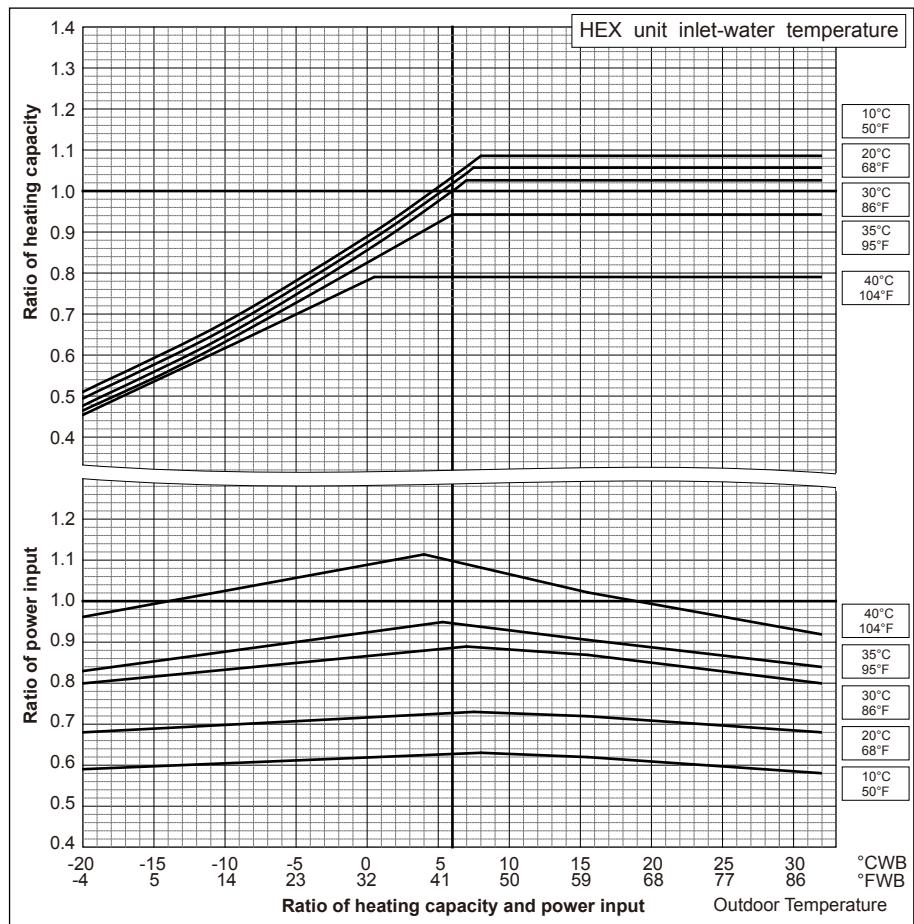

6. CAPACITY TABLES

PUHY-		RP450YSJM-B	RP500YSJM-B
Nominal Cooling Capacity	kW	50.0	56.0
	BTU/h	170,600	191,100
Input	kW	13.77	15.68

PUHY-		RP550YSJM-B	RP600YSJM-B
Nominal Cooling Capacity	kW	63.0	69.0
	BTU/h	215,000	235,400
Input	kW	17.50	18.59

PUHY-		RP650YSJM-B
Nominal Cooling Capacity	kW	73.0
	BTU/h	249,100
Input	kW	21.09

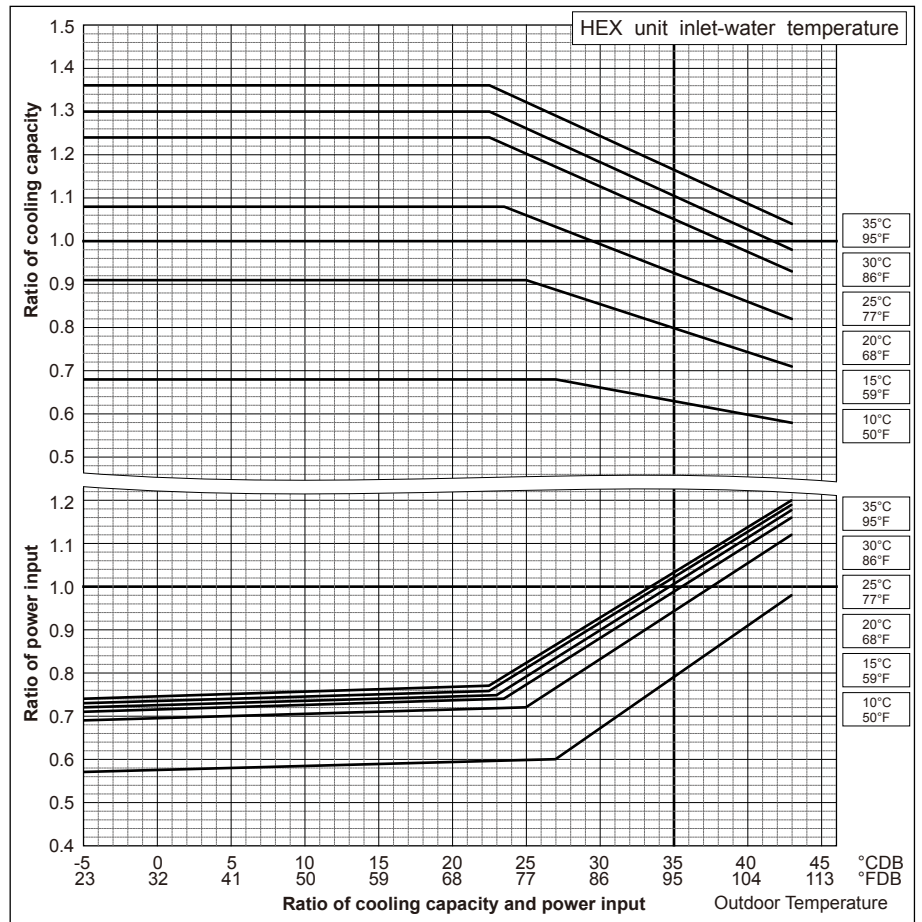

PUHY-		RP450YSJM-B	RP500YSJM-B
Nominal Heating Capacity	kW	56.0	63.0
	BTU/h	191,000	215,000
Input	kW	12.81	14.44

PUHY-		RP550YSJM-B	RP600YSJM-B
Nominal Heating Capacity	kW	69.0	76.5
	BTU/h	235,400	261,000
Input	kW	16.62	19.22

PUHY-		RP650YSJM-B
Nominal Heating Capacity	kW	81.5
	BTU/h	278,100
Input	kW	21.73

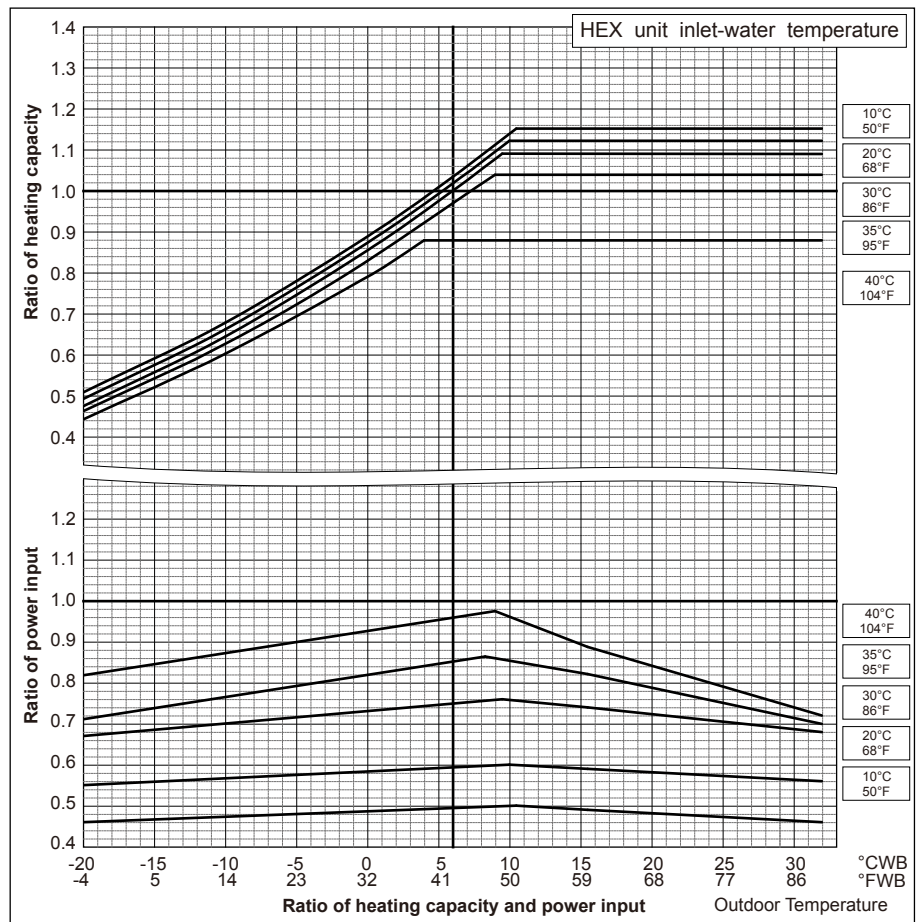

6. CAPACITY TABLES

PUHY-		RP700YSJM-B	RP750YSJM-B
Nominal Cooling Capacity	kW	80.0	85.0
	BTU/h	273,000	290,000
Input	kW	22.22	24.14

PUHY-		RP800YSJM-B	RP850YSJM-B
Nominal Cooling Capacity	kW	90.0	96.0
	BTU/h	307,100	327,600
Input	kW	25.49	27.11

PUHY-		RP900YSJM-B
Nominal Cooling Capacity	kW	101.0
	BTU/h	344,600
Input	kW	28.29

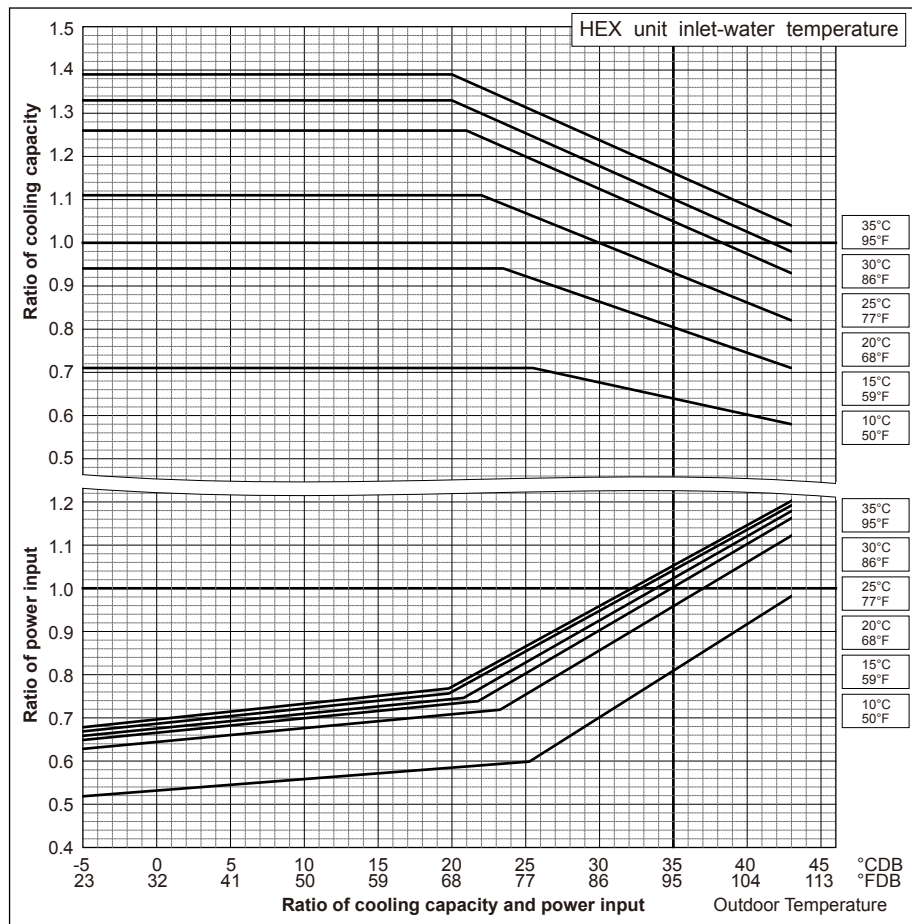

PUHY-		RP700YSJM-B	RP750YSJM-B
Nominal Heating Capacity	kW	88.0	95.0
	BTU/h	300,300	324,100
Input	kW	20.13	21.78

PUHY-		RP800YSJM-B	RP850YSJM-B
Nominal Heating Capacity	kW	100.0	108.0
	BTU/h	341,200	368,500
Input	kW	23.75	26.47

PUHY-		RP900YSJM-B
Nominal Heating Capacity	kW	113.0
	BTU/h	385,600
Input	kW	28.39

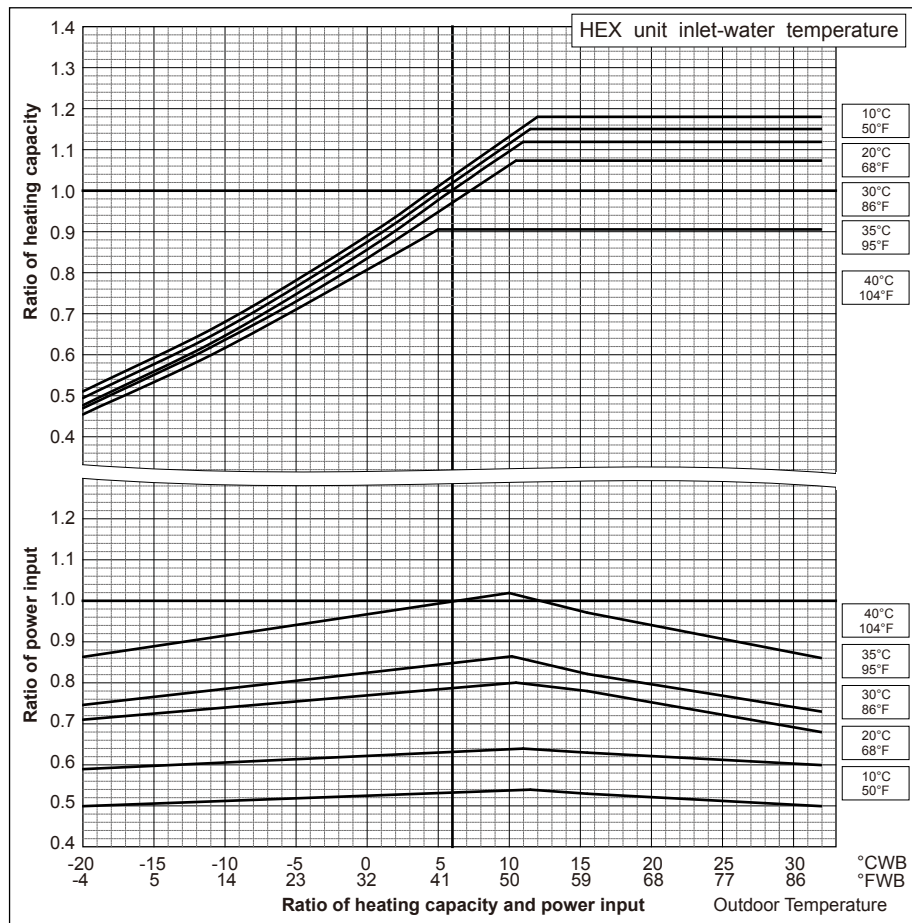

6. CAPACITY TABLES

6-2. Correction by total indoor

CITY MULTI system have different capacities and inputs when many combinations of indoor units with different total capacities are connected. Using following tables, the maximum capacity can be found to ensure the system is installed with enough capacity for a particular application.

PUHY-RP200, 250YJM-B(-BS)

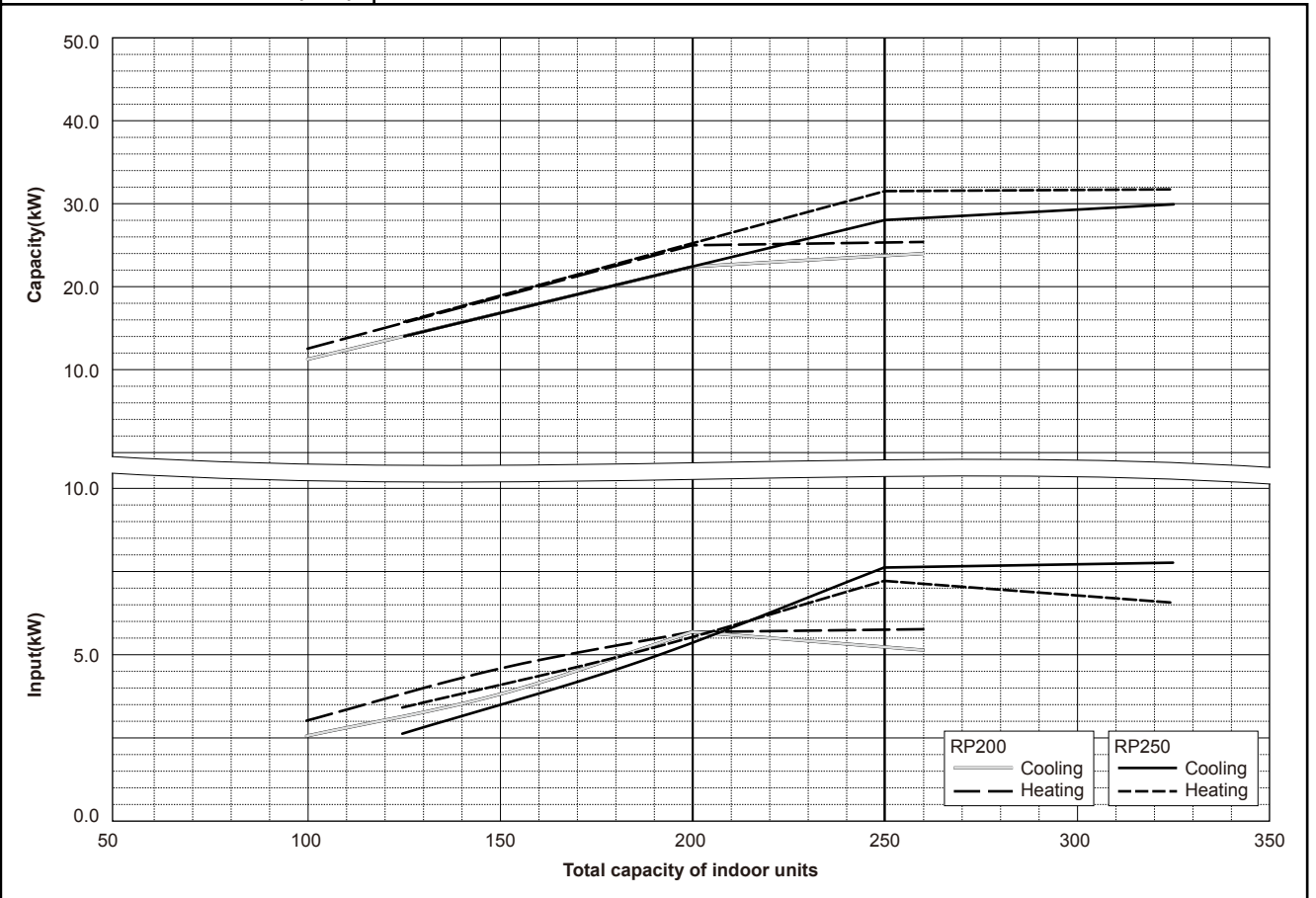

PUHY-RP300, 350YJM-B(-BS)

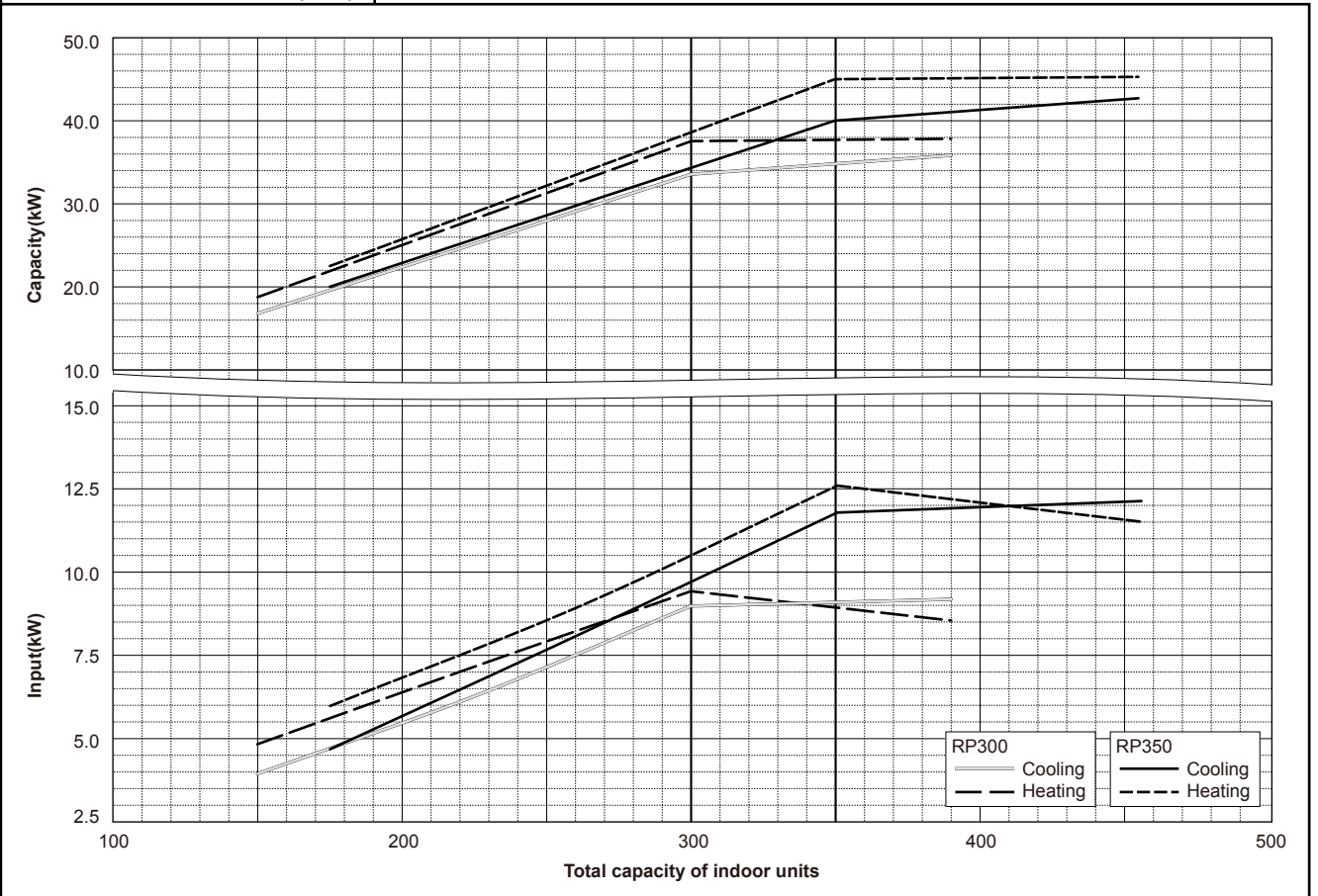

6. CAPACITY TABLES

PUHY-RP400, 450YSJM-B(-BS)

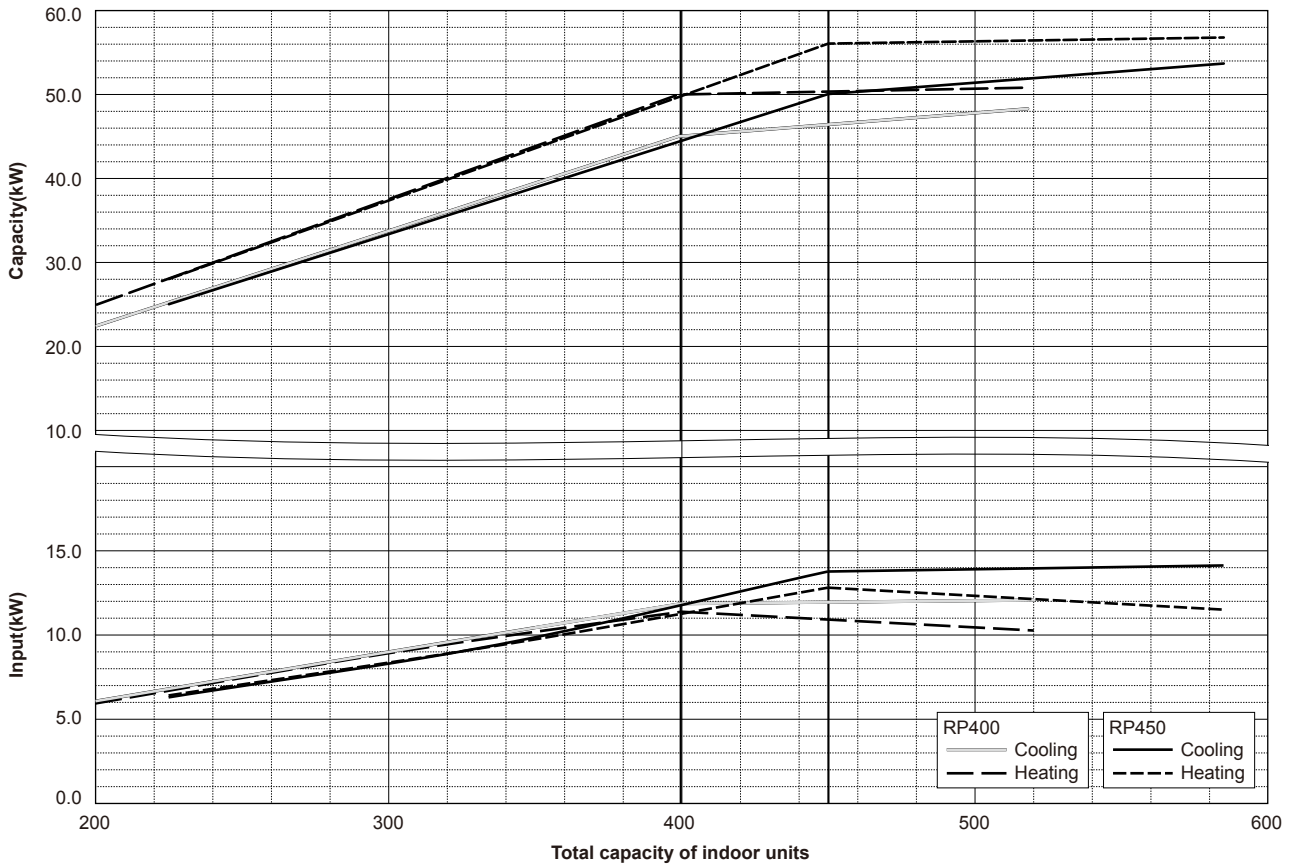

PUHY-RP500, 550YSJM-B(-BS)

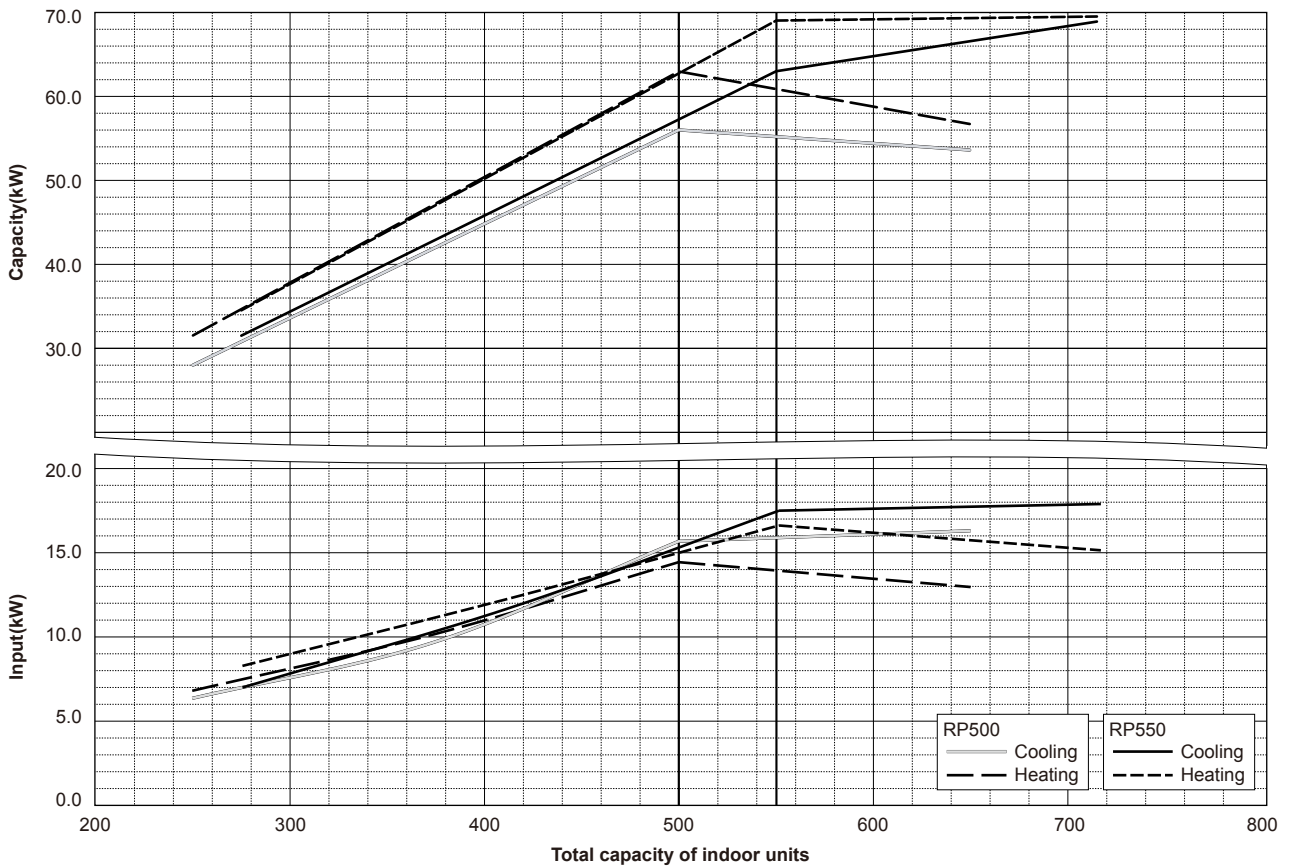

6. CAPACITY TABLES

PUHY-RP600,650YSJM-B(-BS)

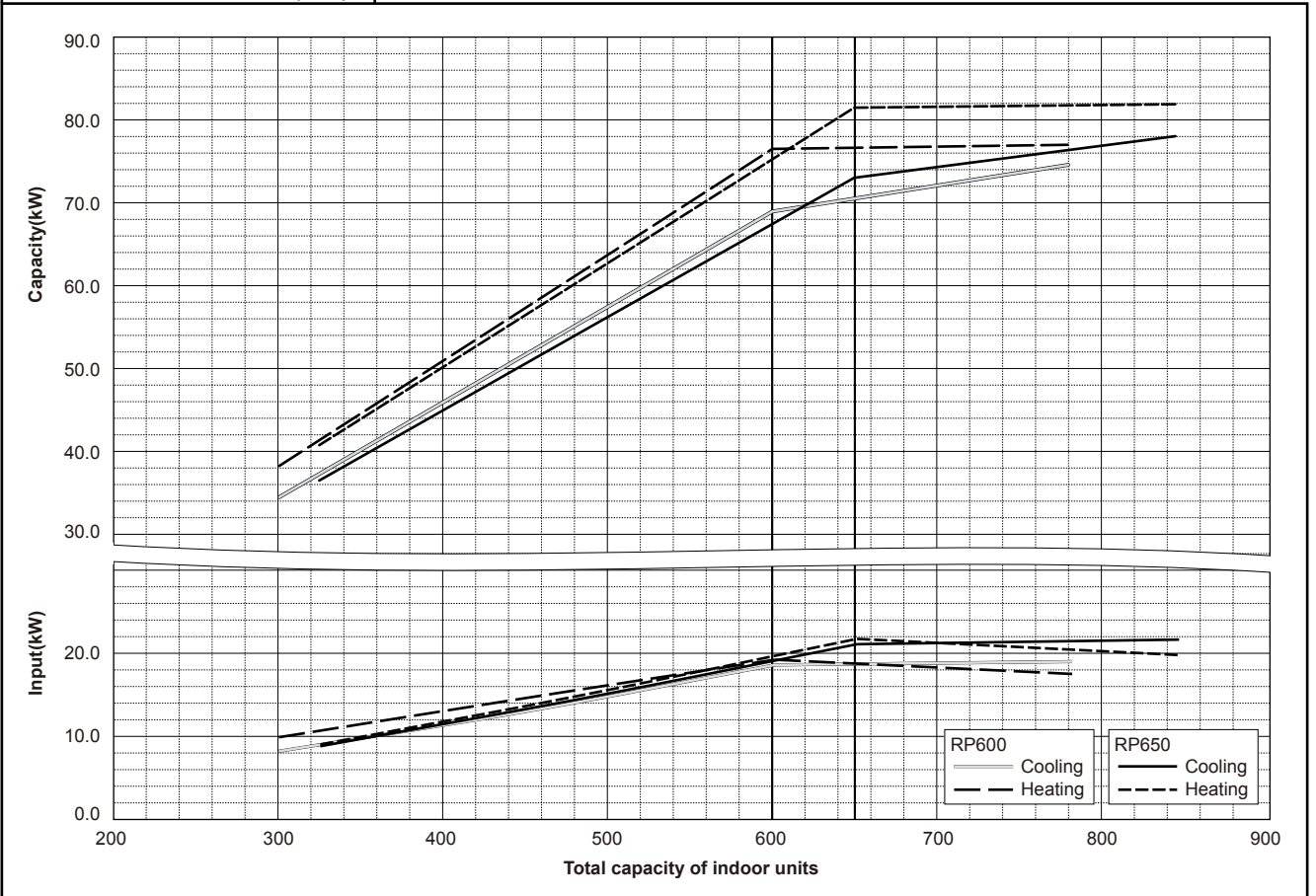

PUHY-RP700,750YSJM-B(-BS)

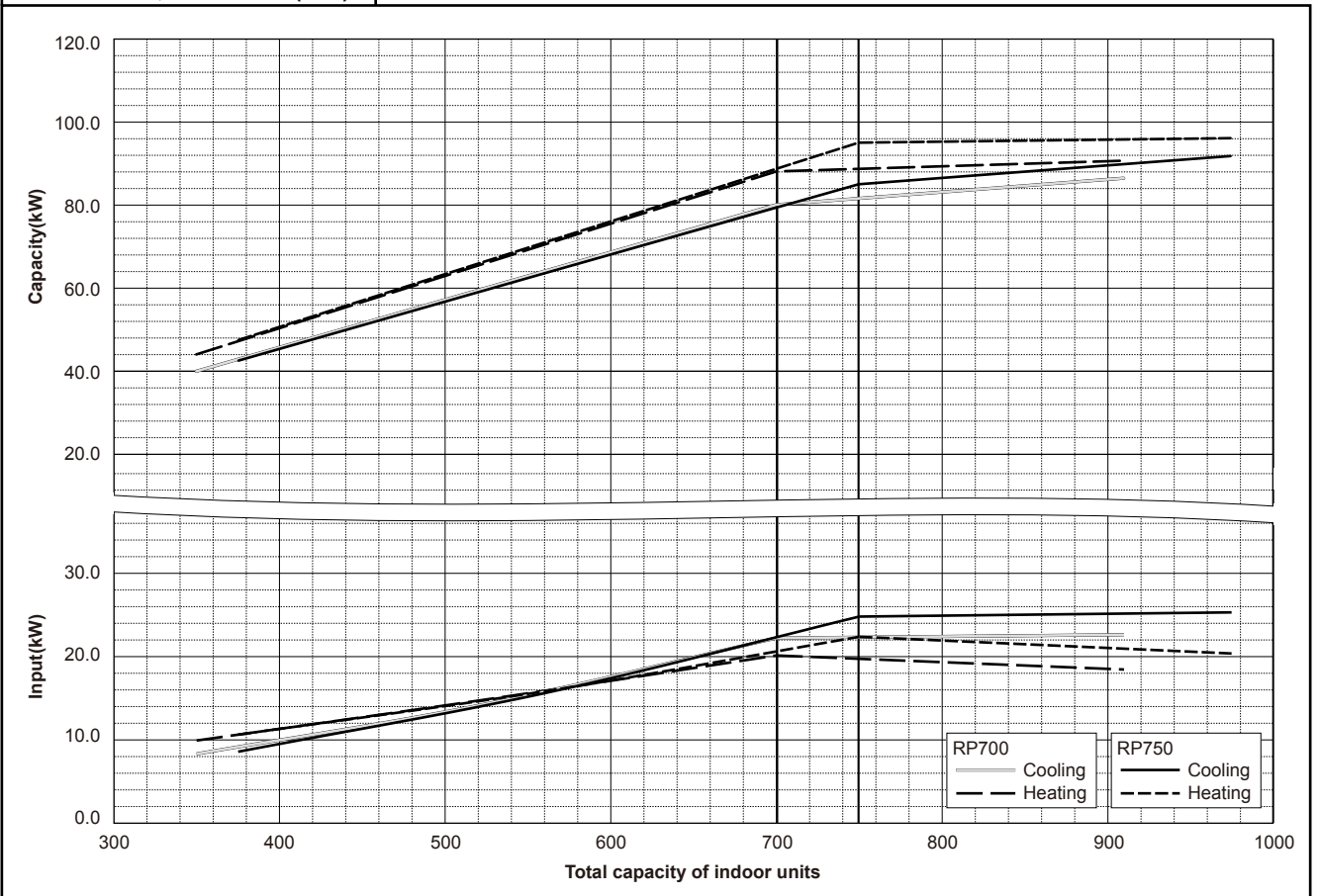

6. CAPACITY TABLES

PUHY-RP800, 850YSJM-B(-BS)

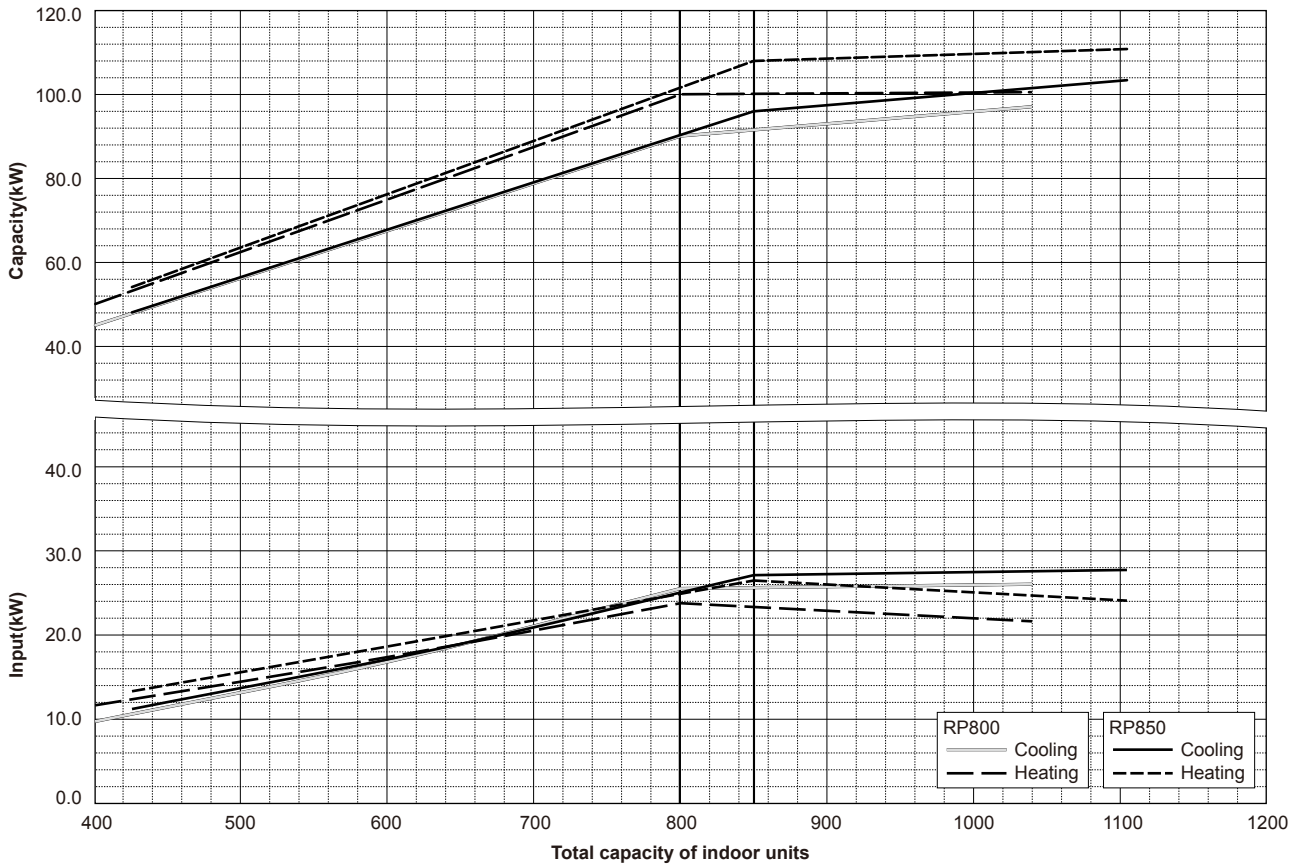

PUHY-RP900YSJM-B(-BS)

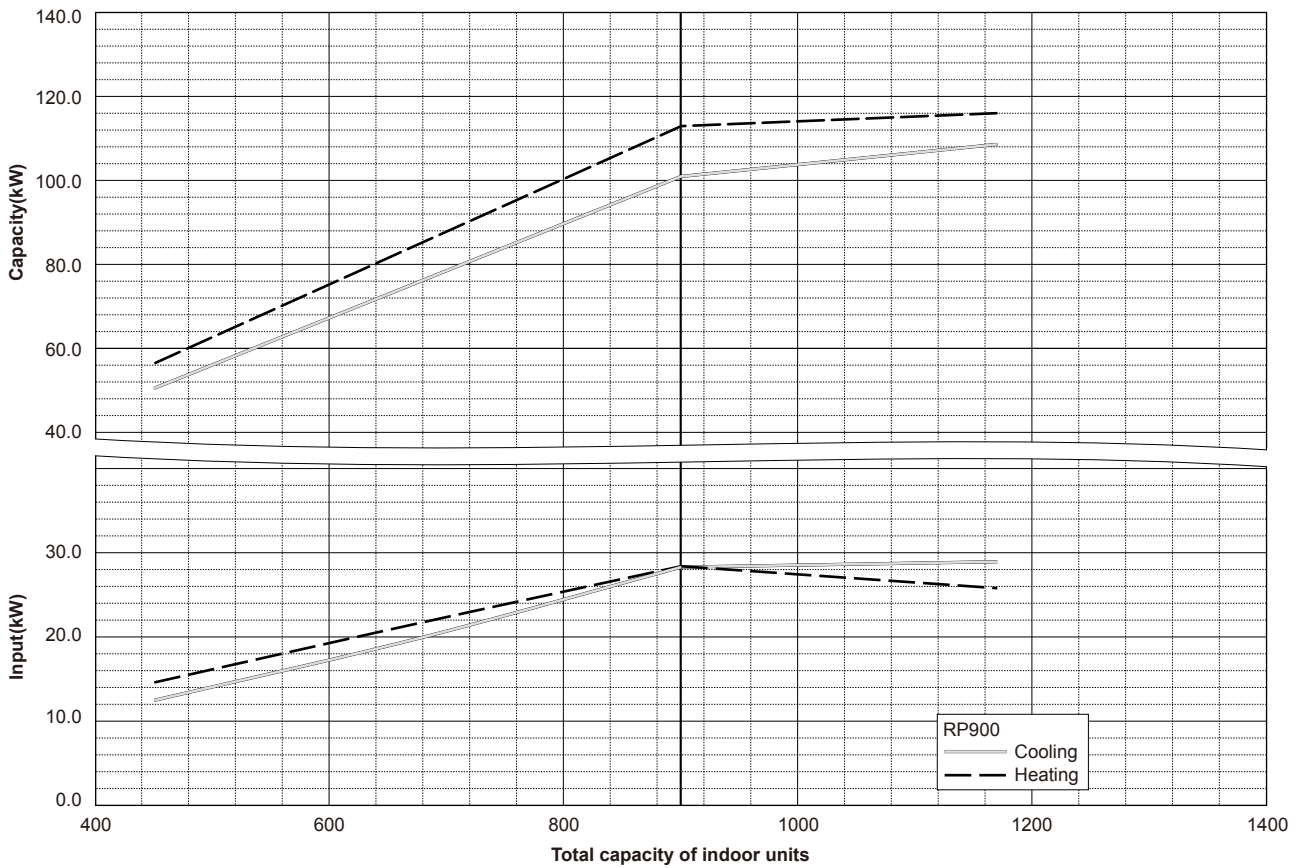

6. CAPACITY TABLES

6-3. Correction by refrigerant piping length

CITY MULTI system can extend the piping flexibly within its limitation for the actual situation. Yet, a decrease of cooling/heating capacity could happen correspondently. Using following correction factor according to the equivalent length of the piping shown at 6-3-1 and 6-3-2, the capacity can be observed. 6-3-3 shows how to obtain the equivalent length of piping.

6-3-1. Cooling capacity correction

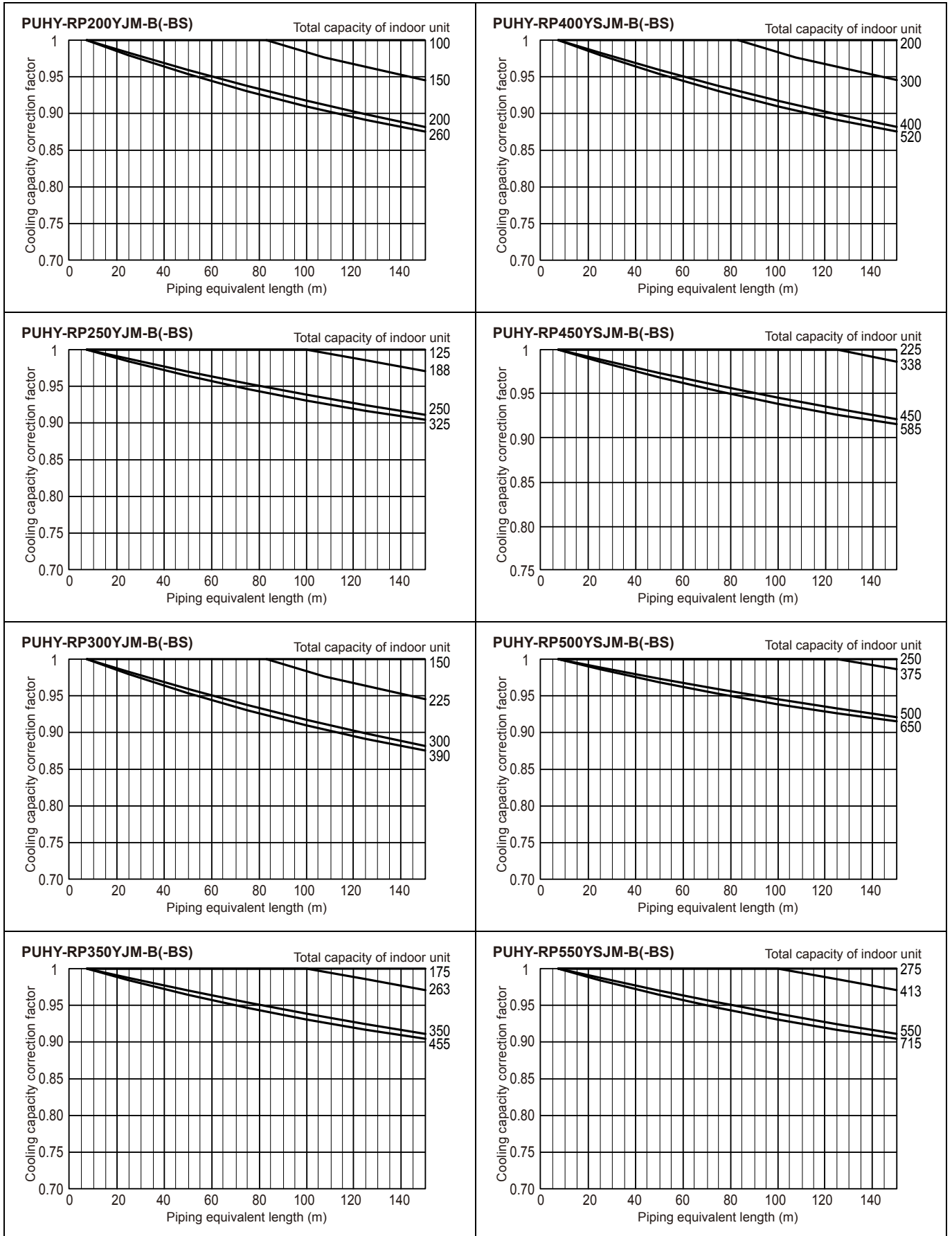

6. CAPACITY TABLES

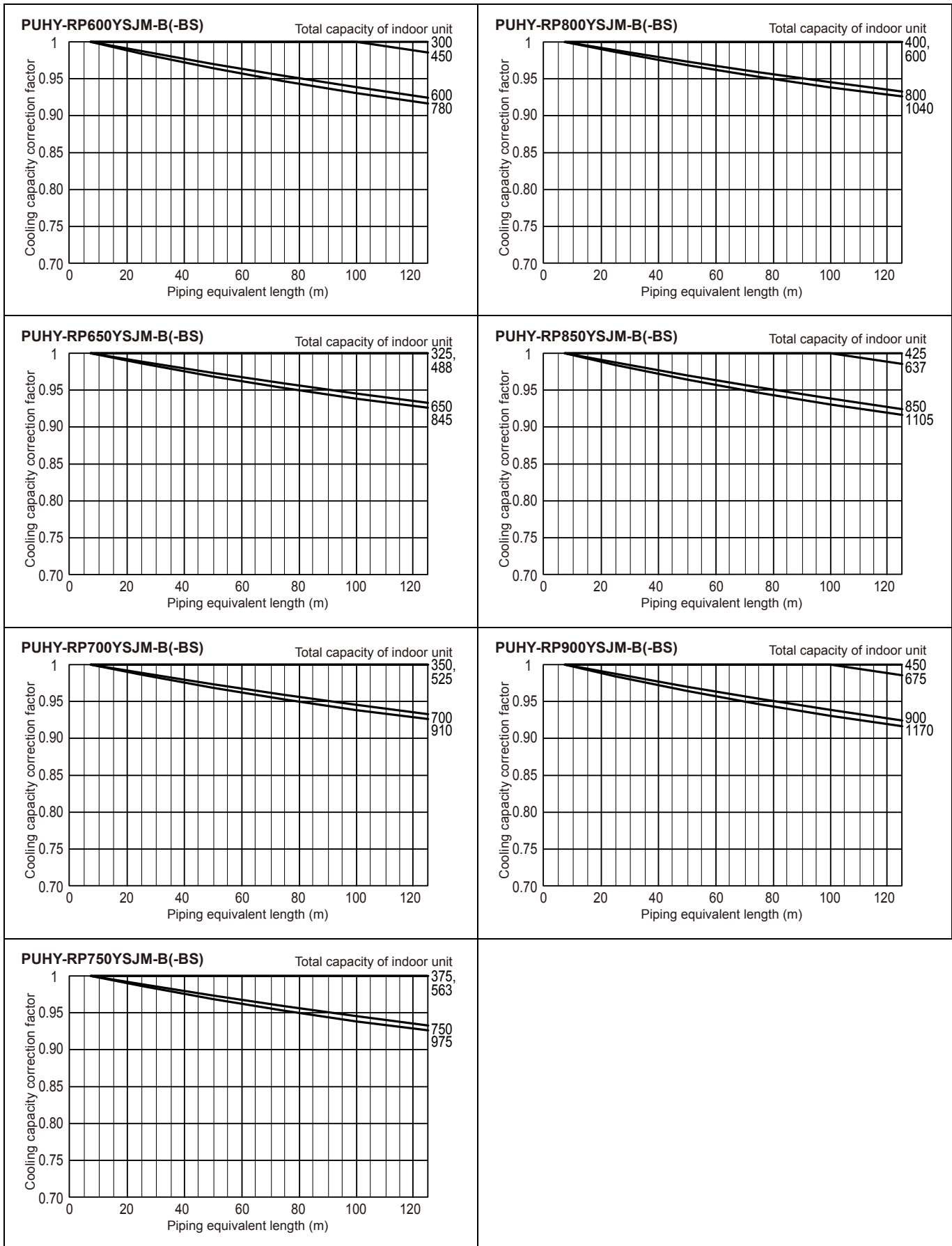

6. CAPACITY TABLES

6-3-2. Heating capacity correction

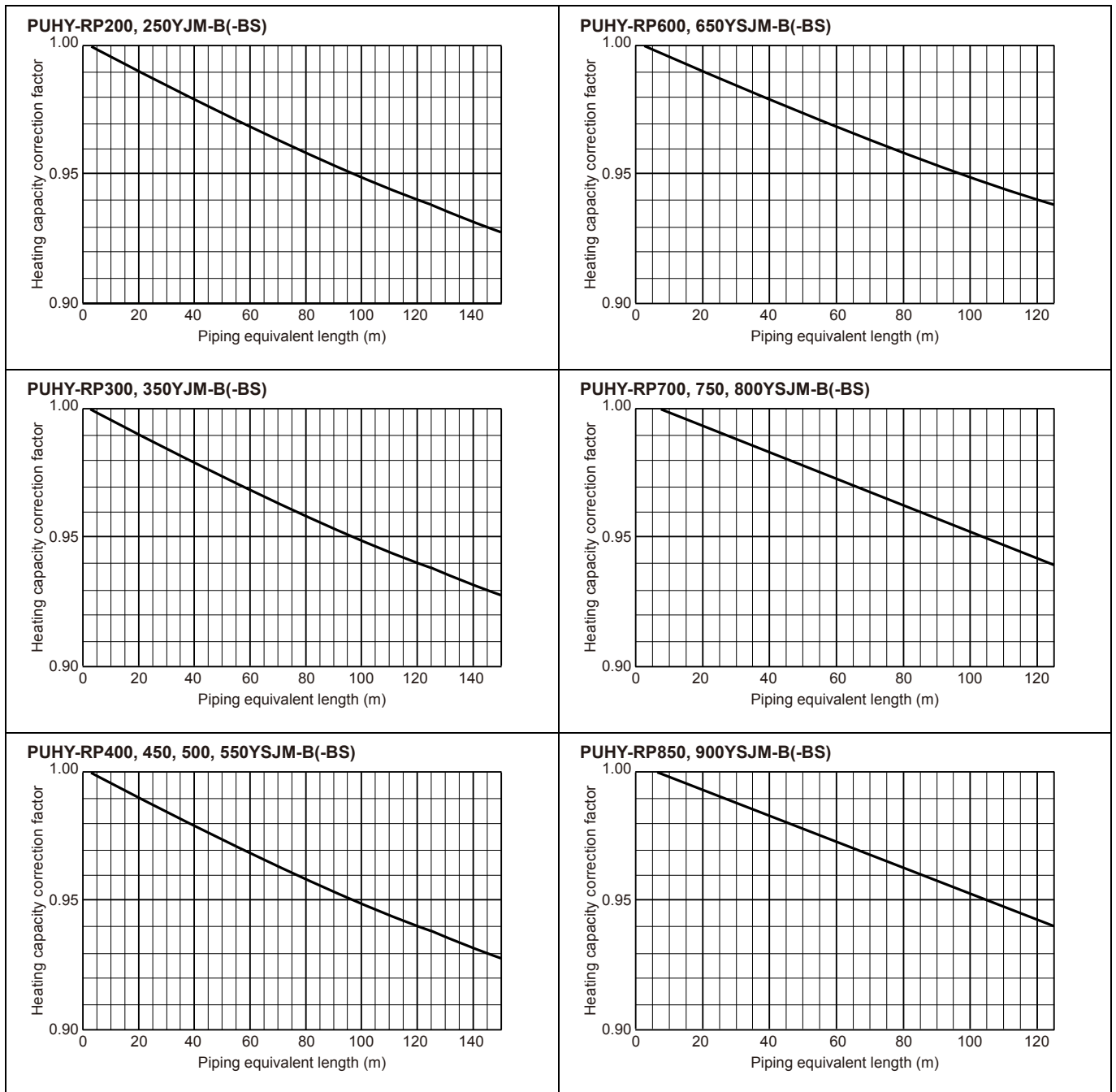

6-3-3. How to obtain the equivalent piping length

1. PUHY-RP200YJM-B(-BS)

Equivalent length = (Actual piping length to the farthest indoor unit) + (0.35 x number of bent on the piping) [m]

2. PUHY-RP250, 300YJM-B(-BS)

Equivalent length = (Actual piping length to the farthest indoor unit) + (0.42 x number of bent on the piping) [m]

3. PUHY-RP350YJM-B(-BS)

Equivalent length = (Actual piping length to the farthest indoor unit) + (0.47 x number of bent on the piping) [m]

4. PUHY-RP400, 450, 500, 550, 600, 650YSJM-B(-BS)

Equivalent length = (Actual piping length to the farthest indoor unit) + (0.50 x number of bent on the piping) [m]

5. PUHY-RP700, 750, 800YSJM-B(-BS)

Equivalent length = (Actual piping length to the farthest indoor unit) + (0.70 x number of bent on the piping) [m]

6. PUHY-RP850, 900YSJM-B(-BS)

Equivalent length = (Actual piping length to the farthest indoor unit) + (0.80 x number of bent on the piping) [m]

6. CAPACITY TABLES

6-4. Correction at frost and defrost

Due to frost at the outdoor heat exchanger and the automatic defrost operation, the heating capacity of the outdoor unit can be calculated by multiplying the correction factor shown in the table below.

Table of correction factor at frost and defrost

Outdoor inlet air temp. °C	6	4	2	1	0	-2	-4	-6	-8	-10	-20
Outdoor inlet air temp. °F	43	39	36	34	32	28	25	21	18	14	14
PUHY-RP200YJM-B(-BS)	1.00	0.93	0.85	0.83	0.84	0.86	0.90	0.90	0.95	0.95	0.95
PUHY-RP250YJM-B(-BS)	1.00	0.93	0.85	0.83	0.84	0.86	0.90	0.90	0.95	0.95	0.95
PUHY-RP300YJM-B(-BS)	1.00	0.93	0.82	0.80	0.82	0.86	0.90	0.90	0.95	0.95	0.95
PUHY-RP350YJM-B(-BS)	1.00	0.93	0.85	0.83	0.84	0.86	0.90	0.90	0.95	0.95	0.95
PUHY-RP400YSJM-B(-BS)	1.00	0.93	0.85	0.83	0.84	0.86	0.90	0.90	0.95	0.95	0.95
PUHY-RP450YSJM-B(-BS)	1.00	0.93	0.85	0.83	0.84	0.86	0.90	0.90	0.95	0.95	0.95
PUHY-RP500YSJM-B(-BS)	1.00	0.94	0.87	0.86	0.87	0.88	0.90	0.90	0.93	0.93	0.93
PUHY-RP550YSJM-B(-BS)	1.00	0.94	0.87	0.86	0.87	0.88	0.90	0.90	0.93	0.93	0.93
PUHY-RP600YSJM-B(-BS)	1.00	0.94	0.87	0.86	0.87	0.88	0.90	0.90	0.93	0.93	0.93
PUHY-RP650YSJM-B(-BS)	1.00	0.98	0.89	0.88	0.89	0.90	0.92	0.95	0.95	0.95	0.95
PUHY-RP700YSJM-B(-BS)	1.00	0.94	0.87	0.86	0.87	0.88	0.90	0.90	0.93	0.93	0.93
PUHY-RP750YSJM-B(-BS)	1.00	0.94	0.87	0.86	0.87	0.88	0.90	0.90	0.93	0.93	0.93
PUHY-RP800YSJM-B(-BS)	1.00	0.98	0.89	0.88	0.89	0.90	0.92	0.95	0.95	0.95	0.95
PUHY-RP850YSJM-B(-BS)	1.00	0.94	0.87	0.86	0.87	0.88	0.90	0.90	0.93	0.93	0.93
PUHY-RP900YSJM-B(-BS)	1.00	0.98	0.89	0.88	0.89	0.90	0.92	0.95	0.95	0.95	0.95

6. CAPACITY TABLES

6-5. Operation temperature range

• Cooling

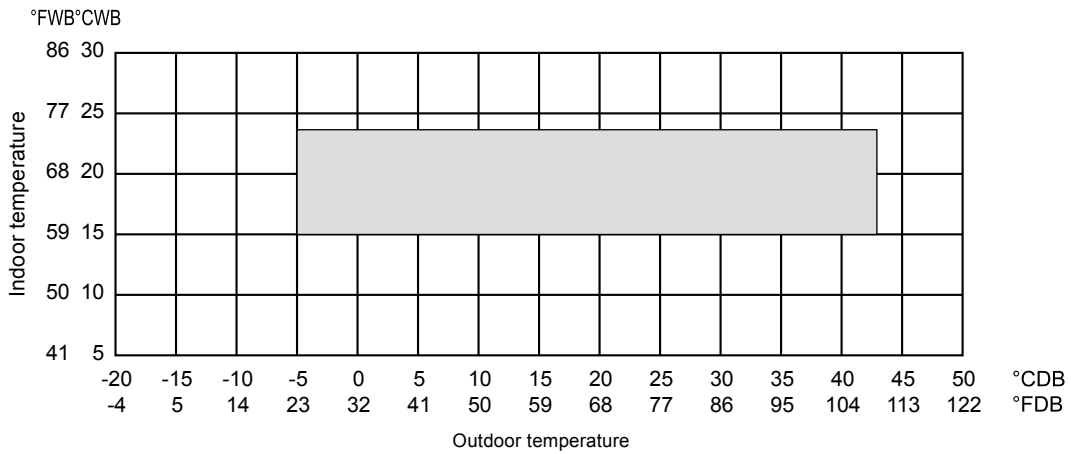

• Heating

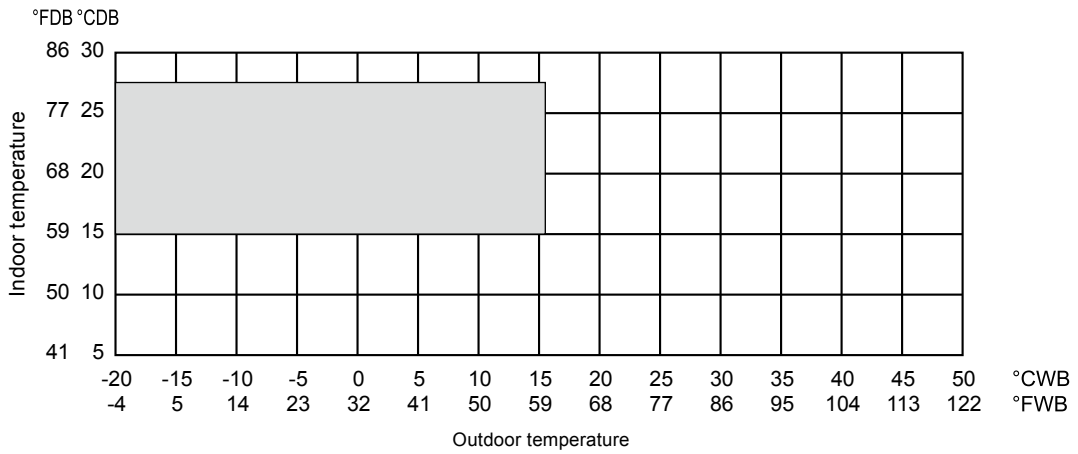

7. OPTIONAL PARTS

7-1. OUTDOOR TWINNING KIT

For PUHY-RP-YSJM, following optional Outdoor Twinning Kit is needed to use to combine to refrigerant flows of its PUHY-RP-YJM. Details of selecting the proper kit should be referred to the System Design Section.

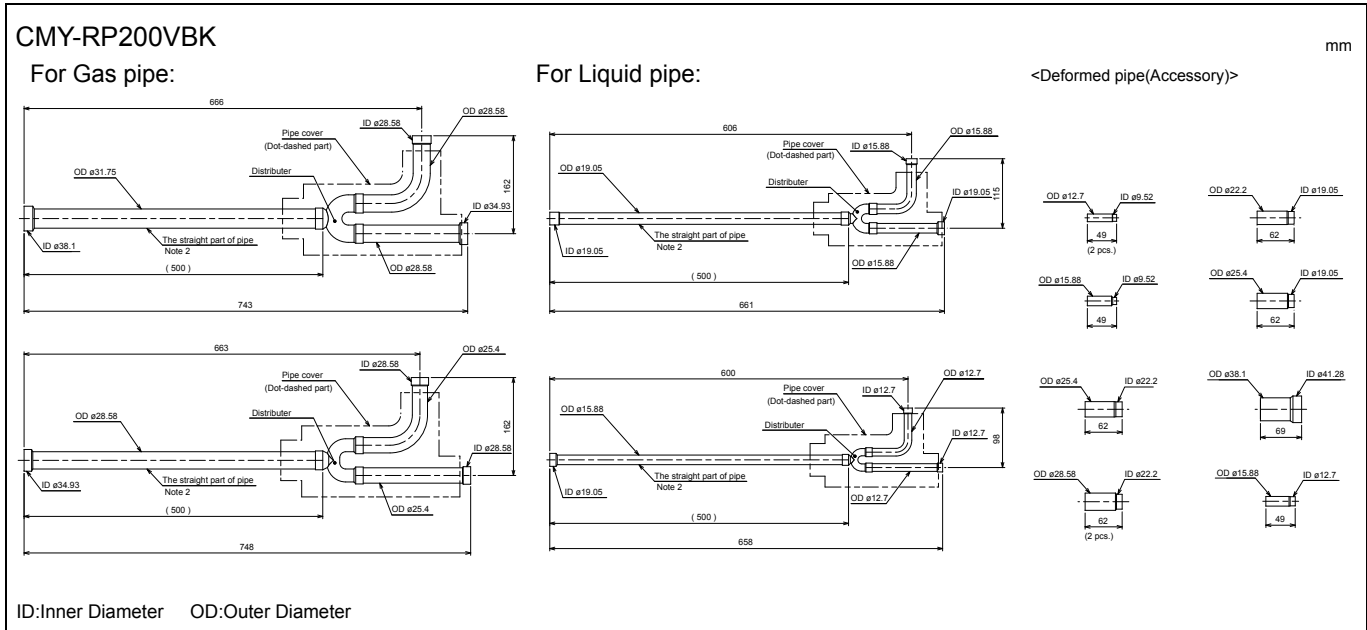
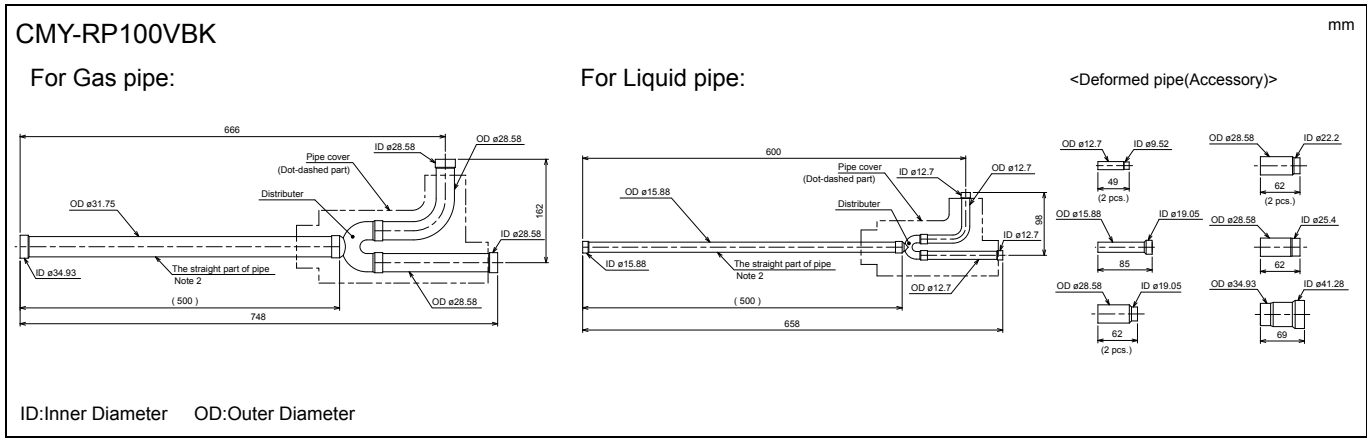

Note 1. Reference the attitude angle of the branch pipe below the fig.

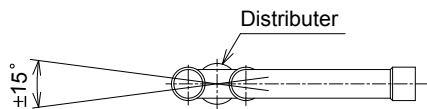

The angle of the branch pipe is within $\pm 15^\circ$ against the horizontal plane.

2. The length of the straight part of pipe connected in front of the twinning pipe must be 500mm or longer. Removing, cutting and bending the twinning kit will cause damage the unit.
3. Pipe diameter is indicated by inside diameter.

8. UNIT SELECTION

8-1. Indoor and outdoor unit selection

(1) Selecting indoor units

- 1) Calculate the thermal load of each room.
- 2) Based on the thermal load corrected for indoor unit return air temperature, select appropriate indoor unit models. Refer to the correction factor diagram for the outdoor unit whose capacity is the closest to the total thermal load of the system (Q_i). Refer to "CAPACITY TABLES (Indoor unit)" and "6. CAPACITY TABLES."
- 3) Calculate the total capacity of the indoor units in the system (N).

(2) Selecting outdoor units

- 1) Based on the total capacity of the indoor units (N), tentatively select the capacity of the outdoor unit (X). The total capacity of the indoor units to be connected to a given outdoor unit (N) should not exceed the maximum connectable capacity of the outdoor unit.
- 2) The tentatively selected standard capacity of the outdoor unit (X) will be defined as Q_s .
* If the total capacity of the indoor units that are connected to a given outdoor unit exceeds 100% of the outdoor unit capacity (X), refer to the outdoor unit partial load capacity table, find the capacity that corresponds to the total capacity N , and use it as the standard outdoor unit capacity (Q_s).
- 3) Obtain the maximum outdoor unit capacity (Q_m) by multiplying Q_s (standard outdoor unit capacity) by the following correction factors: piping length, outside air temperature, and defrost (heating). Find the piping length correction factor from the diagram that corresponds to the total indoor unit capacity (N).

$$Q_m = Q_s \times \text{Piping length correction factor} \times \text{Outside air temperature correction factor} \\ \times \text{Defrost correction factor (heating only)} \times \text{Pipe diameter correction factor}$$

Outside air temperature correction factor	Refer to 6-1.
Piping length correction factor	Refer to 6-3.
Defrost correction factor (heating only)	Refer to 6-4.
Pipe diameter correction factor (applicable only if non-standard size pipes are connected)	Refer to 8-3.

- 4) Make sure the maximum outdoor unit capacity Q_m is equal to or greater than the total thermal load Q_i . If Q_m is smaller than Q_i , reconsider the outdoor unit capacity (X) so that $Q_m \geq Q_i$ will hold true.
- 5) After selecting indoor and outdoor units, calculate the apportioned indoor unit capacity, and make sure that the formula "Thermal load \leq Indoor unit capacity" will hold true for each room. If the thermal load exceeds the indoor unit capacity in one or more rooms, increase the indoor unit size as long as doing so will not exceed the maximum connectable capacity of the outdoor unit. Then, start over from step 1) above. If the maximum connectable capacity is exceeded by increasing the indoor unit capacity, increase the outdoor capacity as well, then start over from step 1) above.

Calculate the indoor/outdoor unit capacities and check for unit compatibility by considering both the heating and the cooling loads. If the formula $Q_m \geq Q_i$ does not hold true for either cooling or heating, reconsider the outdoor unit capacity (X).

8. UNIT SELECTION

(3) Obtaining the unit capacity

A. If the apportioned indoor unit capacity obtained in step 5) on the previous page is equal to or greater than the rated indoor unit capacity, the following formula will be used to calculate the indoor unit capacity: "Rated capacity x return air temperature correction factor x piping length correction factor (x pipe diameter correction factor)".

B. If the apportioned indoor unit capacity obtained in step 5) on the previous page is smaller than the rated indoor unit capacity, the following formula will be used to calculate the indoor unit capacity: "Apportioned indoor unit capacity x return air temperature correction factor."

* The standard outside air temperatures used to obtain the return air temperature correction factor is 35°CDB for cooling and 6°CWB for heating.

* If non-standard size pipes are connected, use the pipe diameter correction factors for the main pipes, merge pipes, and branch pipes.

(4) Notes

When deciding the outside air temperature to calculate unit capacity requirements, take into consideration the possible temperature rise around the outdoor unit due to short-cycling. (When installing outdoor units collectively on the rooftop or if outdoor units are surrounded by walls or other objects, it is recommended to set the outside temperature as 43°C for calculation.)

If you want to take sensible heat load into consideration, refer to the relevant catalogs for information on sensible heat factor when selecting indoor units.

8. UNIT SELECTION

8-2. Calculation samples

(1) To connect indoor units using the standard pipes

Design conditions

<Cooling> Indoor design dry-bulb temperature: 26°C/Indoor design wet-bulb temperature: 18.5°C

Outdoor design dry-bulb temperature: 36°C

Cooling load: 13.5 kW for each of the two rooms

<Heating> Indoor design dry-bulb temperature: 21°C

Outdoor design wet-bulb temperature: 5°C

Heating load: 14.5 kW for each of the two rooms

<Miscellaneous information>

Main piping: \varnothing 28.58 x 45 m, Branch piping: \varnothing 19.05 x 5 m (Equivalent indoor and outdoor piping length: 50 m)

A. Calculating the cooling load

- a) The thermal load (13.5 kW/room), indoor unit return air temperature correction factor, and piping length correction factor are used to calculate the required indoor unit capacity, based on which a 125 model of indoor unit is tentatively selected. (Because the total thermal load is 27 kW, the air temperature correction diagram for the 250 model outdoor unit will be used.)
- b) Because the total capacity of indoor units (N) is 250, the 250 model outdoor unit is tentatively selected. Based on the above, the standard capacity Q_s will be 28 kW.
- c) The correction values obtained from the air temperature correction factor graph and the piping length correction factor graph for the 250 model outdoor units are as follows:
Outside air temperature 36°CDB Capacity correction factor 0.99 (at the standard indoor wet-bulb temperature of 19°C)
Piping length: 50 m Capacity correction factor: 0.97
If the standard capacity Q_s is corrected for indoor/outside air temperatures and piping length, the maximum outdoor unit capacity Q_m can be obtained as follows: $Q_m = 28 \times 0.99 \times 0.97 = 26.8$ kW.
The result shows that the thermal load Q_i (27 kW) exceeds the unit capacity Q_m , so a larger 300 model outdoor unit needs to be selected.
- d) For the 300 model units, the outside air temperature correction factor is 0.99. The piping length correction factor that can be obtained from the diagram for the system whose total indoor unit capacity is 250 would be 0.96.
Because the standard outdoor unit capacity Q_s is 33.5 kW, the maximum outdoor unit capacity Q_m can be obtained using the following formula: $Q_m = 33.5 \times 0.99 \times 0.96 = 31.8$ kW. The result 31.8 kW is greater than the Q_i (27 kW), so the maximum capacity Q_m meets the capacity requirement.
- e) Compare the thermal loads on the indoor units, using the maximum outdoor unit capacity apportioned to each indoor unit and taking the indoor unit return air temperature correction factors into consideration. The correction factor for the return air temperature at 18.5°CWB is 0.99 (at the standard outside dry-bulb temperature of 35°C), and this value can be plugged into the following formula to obtain the capacity.
 $32.1 \text{ kW} \times 125/250 \times 0.99 = 15.8 \text{ kW}$
The result shows that the capacity (15.8 kW) is greater than the thermal load (13.5 kW), and based on this result, two 125 model indoor units and one 300 model outdoor unit can be selected.

B. Calculating the heating load

Next, you will calculate the heating load and unit capacity requirements, using the models that were selected in the previous section.

- a) The standard capacity (Q_s) of the tentatively selected 300 model outdoor unit is 37.5 kW.
- b) Use this value in the following formula to obtain the maximum outdoor unit capacity Q_m as shown below:
 $Q_m = 37.5 \times 1.00 \times 0.965 \times 0.975 = 35.2$ kW, (where the outside air temperature is 5°CWB, capacity correction factor is 1.00 (at the standard indoor dry-bulb temperature of 20°C), defrost correction factor is 0.965, piping length is 50 m, and capacity correction factor is 0.975).
The result shows that the Maximum outdoor unit capacity Q_m (35.2 kW) exceeds the heating load Q_i (29 kW).
- c) You can now check to see if this value will meet the capacity requirement for each indoor unit by using the following formula: $35.2 \times 125/250 \times 0.96 = 16.8$ kW (where the indoor unit return air temperature correction factor at 21°CDB is 0.96) (standard outside temperature at 6°C). The result shows that the unit capacity (16.8 kW) exceeds the thermal load for each room (14.5 kW).

Based on the above calculation, the following indoor and outdoor units can be selected.

Indoor units: 125 model x 2 units

Outdoor unit: RP300 model

C. Calculating the capacity requirement

- a) The cooling capacity of the tentatively selected outdoor unit apportioned to each indoor unit is 15.8 kW, which exceeds the rated cooling capacity of the 125 model unit (14.0 kW). The actual cooling capacity under the specified conditions is calculated as follows: $14.0 \times 0.99 \times 0.97 = 13.4$ kW (where the return air temperature correction factor at the standard outside temperature of 35°CDB is 0.99 and the piping length correction factor is 0.97).
- b) The heating capacity of the tentatively selected outdoor unit apportioned to each indoor unit is 16.8 kW, which exceeds the rated cooling capacity of the 125 model unit (16.0 kW). The actual heating capacity under the specified conditions is calculated as follows: $16.0 \times 0.95 \times 0.975 = 14.8$ kW (where the return air temperature correction factor at the standard outside temperature of 6°CWB is 0.95 and the piping length correction factor is 0.975).

8. UNIT SELECTION

(2) To connect indoor units using non-standard pipes

Design conditions

<Cooling> Indoor design dry-bulb temperature: 26°C/Indoor design wet-bulb temperature: 18.5°C

Outdoor design dry-bulb temperature: 36°C

Cooling load: 13.5 kW for each of the two rooms

<Heating> Indoor design dry-bulb temperature: 21°C

Outdoor design wet-bulb temperature: 5°C

Heating load: 14.5 kW for each of the two rooms

<Miscellaneous information>

Main piping: $\varnothing 25.4 \times 45$ m, Branch piping: $\varnothing 15.88 \times 5$ m (Equivalent indoor and outdoor piping length: 50 m)

A. Calculating the cooling load

a) The thermal load of 13 kW per room and the indoor unit return air temperature correction factor are used to calculate the required indoor unit capacity, based on which a 125 model of indoor unit is tentatively selected. (Because the total thermal load is 26 kW, the air temperature correction diagram for the 250 model outdoor unit will be used.)

b) Because the total capacity of indoor units (N) is 250, the 250 model outdoor unit is tentatively selected.

Based on the above, the standard capacity Q_s will be 28 kW.

c) The correction values obtained from the air temperature correction factor graph and the piping length correction factor graph for the 250 model outdoor units are as follows:

Outside air temperature 36°CDB Capacity correction factor 0.99 (at the standard indoor wet-bulb temperature of 19°C)

Piping length: 50 m Capacity correction factor: 0.97

Main piping: $\varnothing 25.4 \times 45$ m Pipe diameter correction factor: 0.98

The standard capacity Q_s is corrected for indoor/outside air temperatures, piping length, and pipe diameter to obtain the maximum outdoor unit capacity Q_m as follows: $Q_m = 28 \times 0.99 \times 0.97 \times 0.98 = 26.3$ kW. Because this value does not meet the thermal load Q_i (27 kW), a larger 300 model outdoor unit needs to be selected.

d) For the 300 model, the outside air temperature correction factor is 0.99, the pipe diameter correction factor for a 45 m pipe with a diameter of $\varnothing 25.4$ is 0.98, and the piping length correction factor is 0.96 (read from the diagram for the unit whose total indoor unit capacity N is 250).

Where the standard outdoor unit capacity Q_s is 33.5 kW, the maximum outdoor unit capacity Q_m can be obtained as follows: $Q_m = 33.5 \times 0.99 \times 0.98 \times 0.96 = 31.2$ kW. This value is greater than the thermal load Q_i (27 kW), and the maximum capacity Q_m satisfies the capacity requirements.

e) Compare the thermal loads on the indoor unit side, using the maximum outdoor unit capacity apportioned to each indoor unit and taking the indoor unit return air condition correction factors into consideration. The correction factor for the return air temperature at 18.5°C is 0.99 (at the standard outside dry-bulb temperature of 35°C), and the pipe diameter correction factor for a 5 m pipe with a diameter of $\varnothing 15.88$ connected to a 125-model unit is 0.99. These values can be plugged into the following formula to obtain the capacity.

$$31.8 \text{ kW} \times 125/250 \times 0.99 \times 0.99 = 15.5 \text{ kW.}$$

The result shows that the capacity (15.5 kW) is greater than the thermal load of 13.5 kW, and based on this result, two 125 model indoor units and one 300 model outdoor unit can be selected.

B. Calculating the heating load

Next, we will calculate the heating load, using the models that are selected based on the cooling load calculation.

a) The standard capacity Q_s of the tentatively selected (during cooling load calculation) 300 model outdoor unit is 37.5 kW.

b) The correction values obtained from the air temperature correction factor graph and the piping length correction factor graph for the 300 model outdoor units are as follows:

Outside air temperature 5°CWB Capacity correction factor 1.00 (at the standard indoor dry-bulb temperature of 20°C)

Defrost correction factor is 0.975

Piping length: 50 m Capacity correction factor: 0.975

Main piping: $\varnothing 25.4 \times 45$ m Pipe diameter correction factor: 0.98

The standard capacity Q_s is corrected for indoor/outside air temperatures and piping length to obtain the maximum outdoor unit capacity Q_m as follows: $Q_m = 37.5 \times 1.00 \times 0.975 \times 0.975 \times 0.98 = 34.9$ kW.

The result shows that the Maximum outdoor unit capacity Q_m (34.9 kW) exceeds the heating load Q_i (29 kW).

c) You can now check to see if this value will meet the capacity requirement for each indoor unit by using the following formula: $34.9 \times 125/250 \times 0.96 \times 0.99 = 16.5$ kW (where the correction factor for the indoor unit return air temperature of 21°CDB is 0.96 (standard outside temperature at 6°C), and the pipe diameter correction factor for a 5 m branch pipe with a diameter of $\varnothing 15.88$ connected to a 125 models is 0.99. The result shows that the unit capacity 16.5 kW exceeds the thermal load for each room (14.5 kW).

Based on the above calculation, the following indoor and outdoor units can be selected.

Indoor units: 125 model x 2 units

Outdoor unit: RP300 model

8. UNIT SELECTION

<Capacity requirement calculation flow chart>

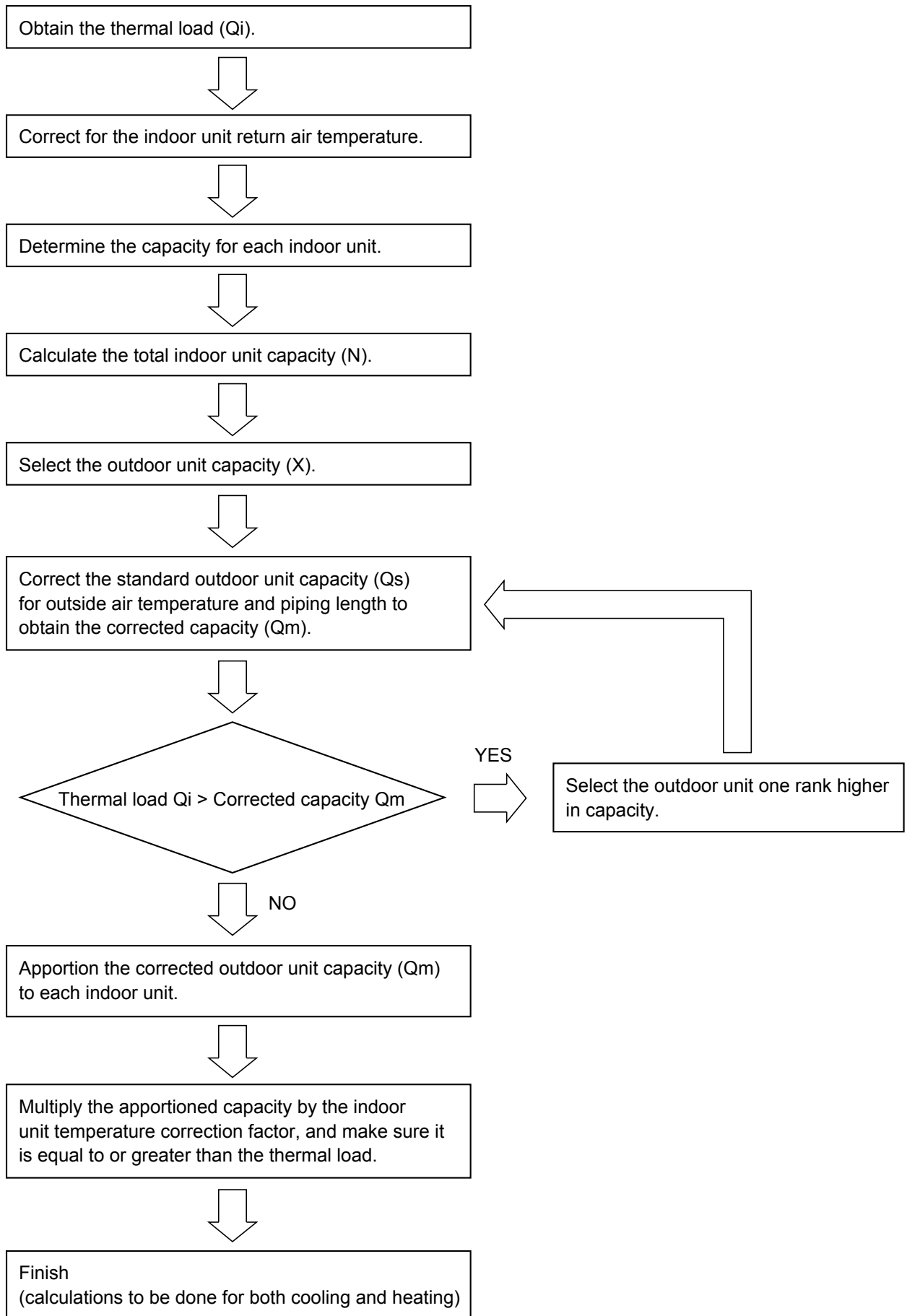

8. UNIT SELECTION

8-3. Pipe diameter correction factor

8-3-1. Correction factors for the outdoor units and main pipe diameter

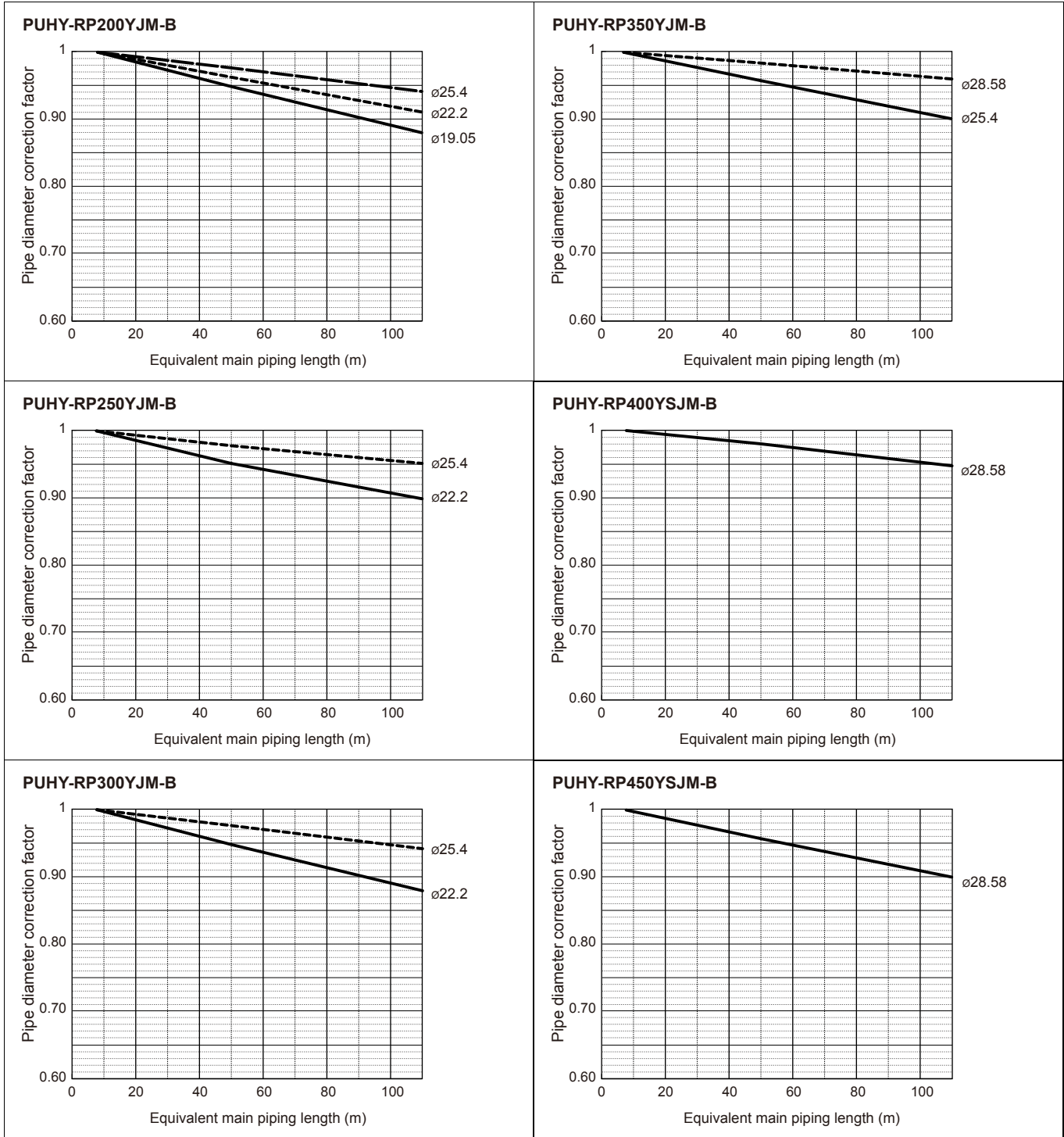

8. UNIT SELECTION

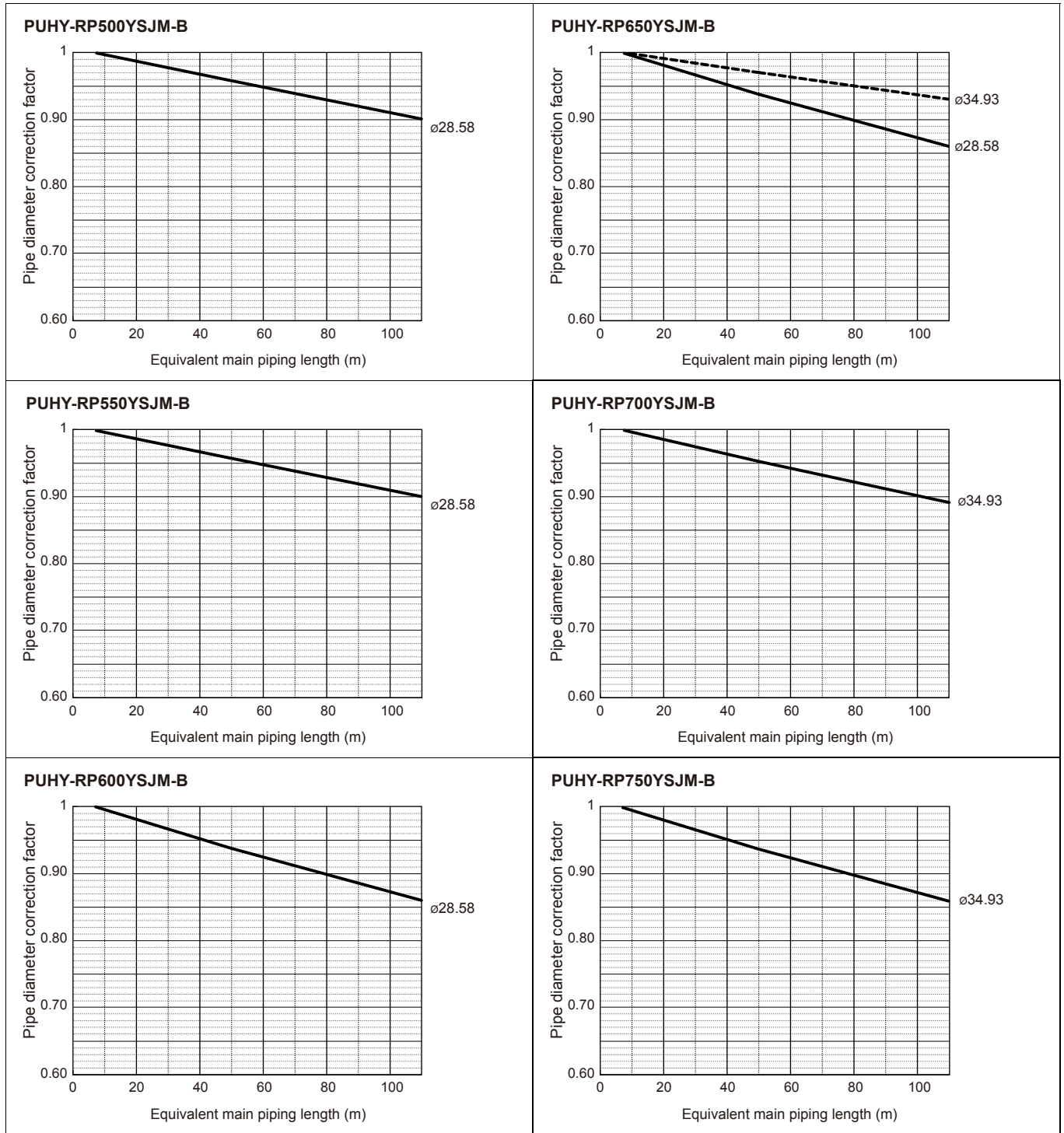

8. UNIT SELECTION

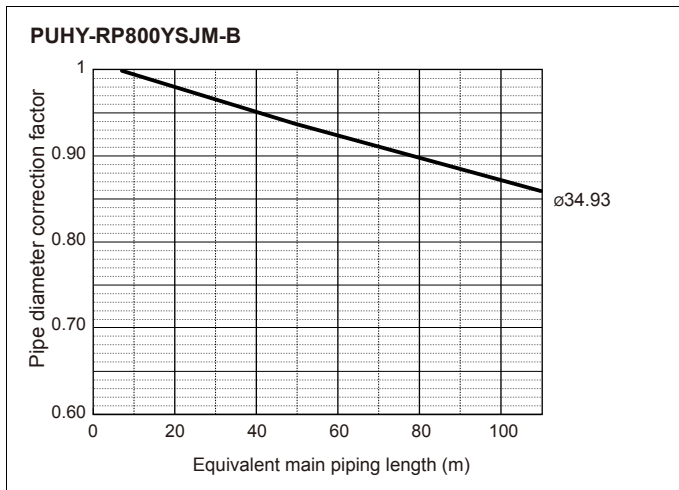

8. UNIT SELECTION

8-3-2. Correction factors for the indoor units and branch pipe diameter

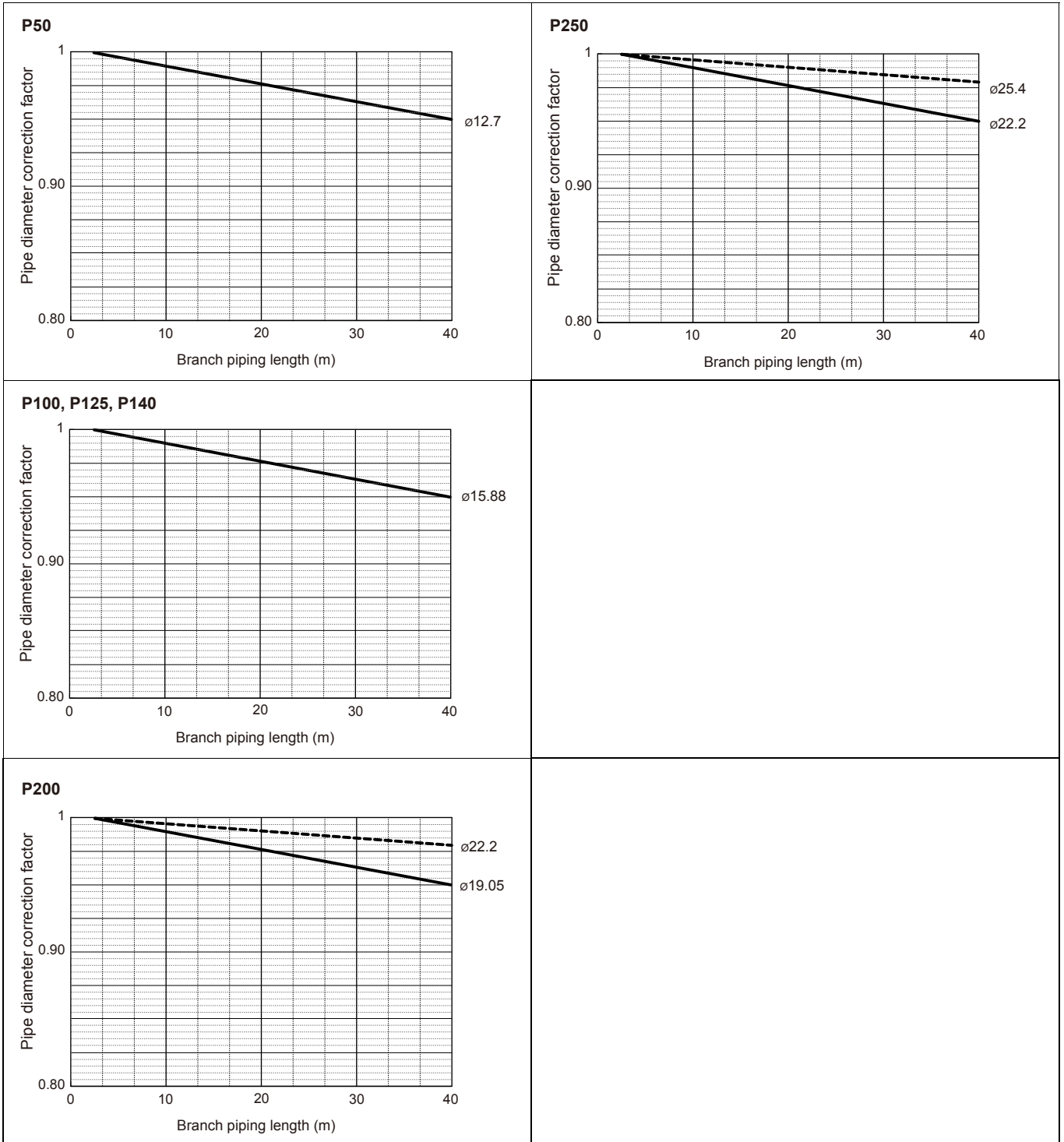

8. UNIT SELECTION

8-3-3. Correction factors for the downstream indoor units and the pipes at the downstream of the branch pipe

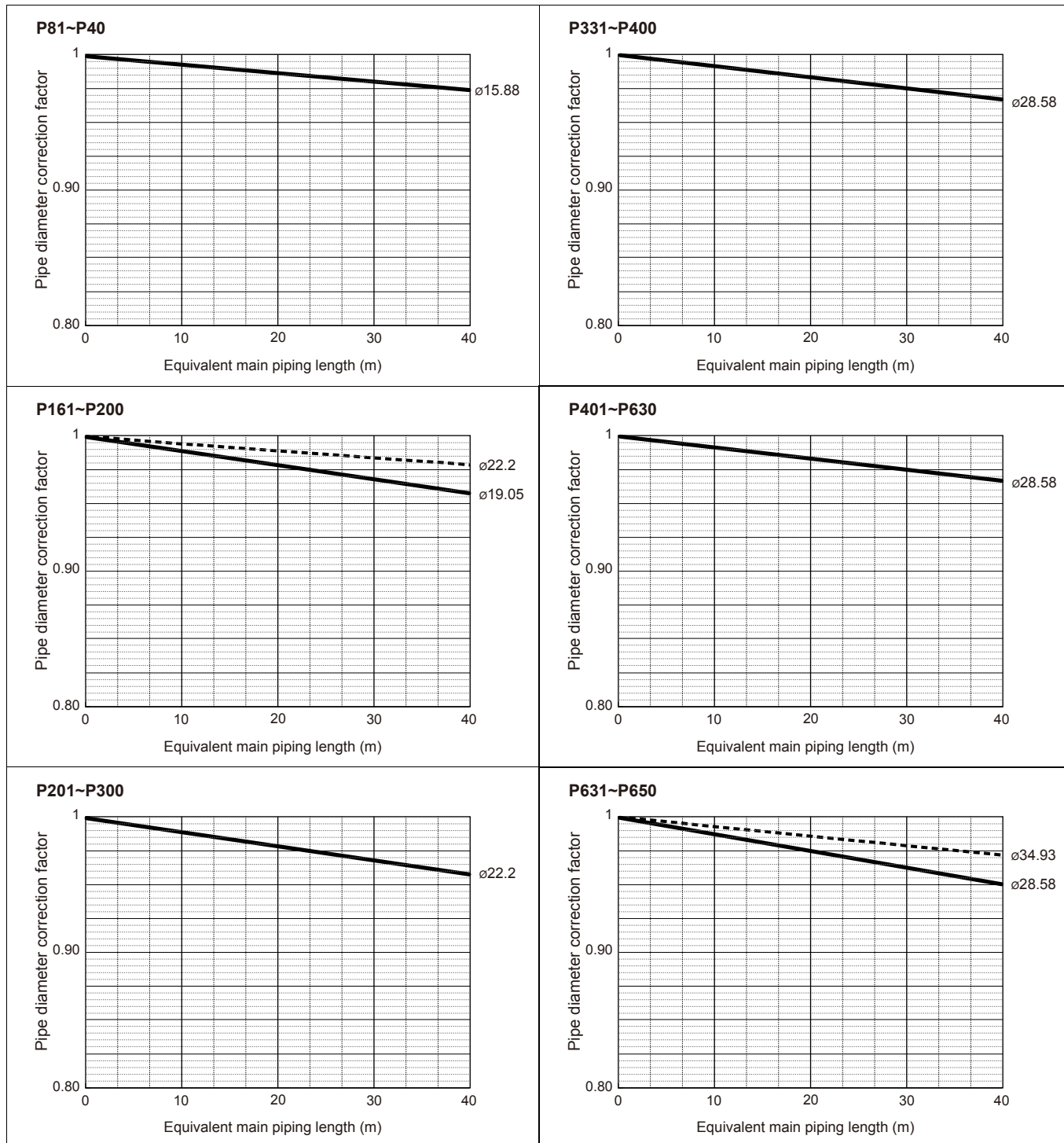

8. UNIT SELECTION

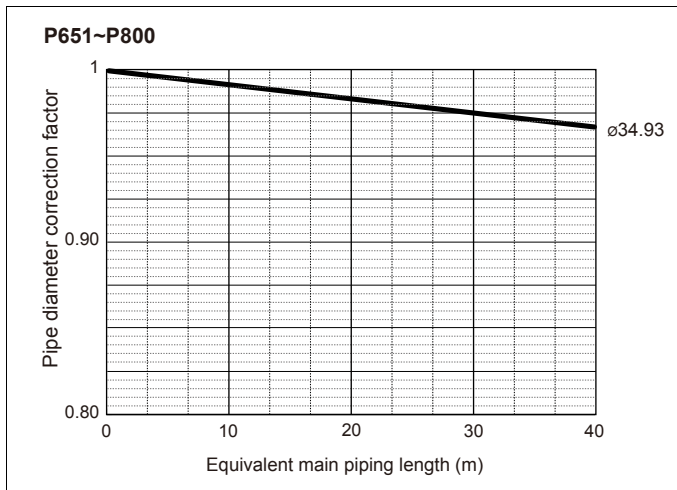

OUTDOOR UNITS

1. SPECIFICATIONS	62
2. EXTERNAL DIMENSIONS	64
3. CENTER OF GRAVITY	66
4. ELECTRICAL WIRING DIAGRAMS	67
5. SOUND LEVELS	68
6. CAPACITY TABLES	69
6-1. Correction by temperature	69
6-2. Correction by total indoor	73
6-3. Correction by refrigerant piping length	74
6-4. Correction by port counts of the BC controller	76
6-5. Correction at frost and defrost	76
6-6. Operation temperature range	77
7. UNIT SELECTION	78
7-1. Indoor and outdoor unit selection	78
7-2. Calculation samples	80
7-3. Pipe diameter correction factor	83

1. SPECIFICATIONS

Model			PURY-RP200YJM-B(-BS)	PURY-RP250YJM-B(-BS)	
Power source			3-phase 4-wire 380-400-415V 50/60Hz	3-phase 4-wire 380-400-415V 50/60Hz	
Cooling capacity (Nominal)	*1	kW	22.4	28.0	
	*1	kcal / h	19,300	24,100	
	*1	BTU / h	76,400	95,500	
		Power input	kW	4.95	6.82
		Current input	A	8.3-7.9-7.6	11.5-10.9-10.5
		COP	kW / kW	4.52	4.10
Temp. range of cooling	Indoor	W.B.	15.0~24.0°C(59~75°F)	15.0~24.0°C(59~75°F)	
	Outdoor	D.B.	-5.0~43.0°C(23~109°F)	-5.0~43.0°C(23~109°F)	
Heating capacity (Nominal)	*2	kW	25.0	31.5	
	*2	kcal / h	21,500	27,100	
	*2	BTU / h	85,300	107,500	
		Power input	kW	5.50	7.22
		Current input	A	9.2-8.8-8.5	12.1-11.5-11.1
		COP	kW / kW	4.54	4.36
Temp. range of heating	Indoor	D.B.	15.0~27.0°C(59~81°F)	15.0~27.0°C(59~81°F)	
	Outdoor	W.B.	-20.0~15.5°C(-4~60°F)	-20.0~15.5°C(-4~60°F)	
Indoor unit connectable	Total capacity		50~150 % of outdoor unit capacity	50~150 % of outdoor unit capacity	
	Model / Quantity		P15~P250 / 1~20	P15~P250 / 1~25	
Sound pressure level (measured in anechoic room)		dB <A>	56	57	
Refrigerant piping diameter	High pressure	mm (in.)	19.05(3/4) Brazed	19.05(3/4) Brazed	
	Low pressure	mm (in.)	28.58(1-1/8) Brazed	28.58(1-1/8) Brazed	
FAN	Type x Quantity		Propeller fan x 1	Propeller fan x 1	
	Air flow rate	m ³ / min	225	225	
		L/s	3,750	3,750	
		cfm	7,945	7,945	
	Control, Driving mechanism		Inverter-control, Direct-driven by motor	Inverter-control, Direct-driven by motor	
	Motor output	kW	0.92 x 1	0.92 x 1	
*3	External static press.	0 Pa (0 mmH ₂ O)	0 Pa (0 mmH ₂ O)		
Compressor	Type x Quantity		Inverter scroll hermetic compressor	Inverter scroll hermetic compressor	
	Manufacture		AC&R Works, MITSUBISHI ELECTRIC CORPORATION	AC&R Works, MITSUBISHI ELECTRIC CORPORATION	
	Starting method		Inverter	Inverter	
	Motor output	kW	5.4	6.8	
	Case heater	kW	0.035(240 V)	0.045(240 V)	
	Lubricant		MEL32	MEL32	
External finish			Pre-coated galvanized steel sheets (+powder coating for -BS type) <MUNSELL 5Y 8/1>	Pre-coated galvanized steel sheets (+powder coating for -BS type) <MUNSELL 5Y 8/1>	
External dimension HxWxD		mm	1,710(1,650 without legs) x 1,220 x 760	1,710(1,650 without legs) x 1,220 x 760	
		in.	67-3/8(65 without legs) x 48-1/16 x 29-15/16	67-3/8(65 without legs) x 48-1/16 x 29-15/16	
Protection devices	High pressure protection		High pressure sensor, High pressure switch at 4.15,3.6MPa (601,522 psi)	High pressure sensor, High pressure switch at 4.15,3.6MPa (601,522 psi)	
	Inverter circuit (COMP. / FAN)		Over-heat protection, Over-current protection	Over-heat protection, Over-current protection	
	Compressor		Discharge thermo protection, Over-current protection	Discharge thermo protection, Over-current protection	
	Fan motor		Thermal switch	Thermal switch	
Refrigerant	Type x original charge		R410A x 11.8kg (27lbs)	R410A x 11.8kg (27lbs)	
	Control		Indoor LEV and BC controller	Indoor LEV and BC controller	
Net weight		kg (lbs)	275(607)	290(640)	
Heat exchanger			Salt-resistant cross fin & copper tube	Salt-resistant cross fin & copper tube	
HIC circuit (HIC: Heat Inter-Changer)			-	-	
Defrosting method			Auto-defrost mode (Reversed refrigerant cycle)	Auto-defrost mode (Reversed refrigerant cycle)	
Drawing	External		KD94G728	KD94G728	
	Wiring		KE94C491	KE94C491	
Standard attachment	Document		Installation Manual	Installation Manual	
	Accessory		Refrigerant conn. pipe	Refrigerant conn. pipe	
Optional parts			Joint: CMY-R160-J1 BC controller: CMB-P104,105,106,108,1010,1013,1016V-G1 Main BC controller: CMB-P108,1010,1013,1016V-GA1 Sub BC controller: CMB-P104,108V-GB1,CMB-P1016V-HB1	Joint: CMY-R160-J1 BC controller: CMB-P104,105,106,108,1010,1013,1016V-G1 Main BC controller: CMB-P108,1010,1013,1016V-GA1 Sub BC controller: CMB-P104,108V-GB1,CMB-P1016V-HB1	
Remarks			<ul style="list-style-type: none"> ●Details on foundation work, duct work, insulation work, electrical wiring, power source switch, and other items shall be referred to the Installation Manual. ●Due to continuing improvement, above specifications may be subject to change without notice. ●Our company is unable to guarantee reliability of pre-existing pipes and pre-existing cables. 		

Notes:

- Nominal cooling conditions (subject to JIS B8615-1)
Indoor: 27°CDB/19°CWB (81°FDB/66°FWB), Outdoor: 35°CDB (95°FDB)
Pipe length: 7.5 m (24-9/16 ft.), Level difference: 0 m (0 ft.)
- Nominal heating conditions (subject to JIS B8615-1)
Indoor: 20°CDB (68°FDB), Outdoor: 7°CDB/6°CWB (45°FDB/43°FWB)
Pipe length: 7.5 m (24-9/16 ft.), Level difference: 0 m (0 ft.)
- External static pressure option is available (30 Pa, 60 Pa/3.1 mmH₂O, 6.1 mmH₂O).

Unit converter

kcal	=kW x 860
BTU/h	=kW x 3,412
cfm	=m ³ /min x 35.31
lbs	=kg / 0.4536

*The specification data is subject to rounding variation.

1. SPECIFICATIONS

Model		PURY-RP300YJM-B(-BS)		
Power source		3-phase 4-wire 380-400-415V 50/60Hz		
Cooling capacity (Nominal)	*1	kW	33.5	
	*1	kcal / h	28,800	
	*1	BTU / h	114,300	
		Power input	kW	8.35
		Current input	A	14.0-13.3-12.9
		COP	kW / kW	4.01
Temp. range of cooling	Indoor	W.B.	15.0~24.0°C(59~75°F)	
	Outdoor	D.B.	-5.0~43.0°C(23~109°F)	
Heating capacity (Nominal)	*2	kW	37.5	
	*2	kcal / h	32,300	
	*2	BTU / h	128,000	
		Power input	kW	8.70
		Current input	A	14.6-13.9-13.4
		COP	kW / kW	4.31
Temp. range of heating	Indoor	D.B.	15.0~27.0°C(59~81°F)	
	Outdoor	W.B.	-20.0~15.5°C(-4~60°F)	
Indoor unit connectable	Total capacity	50~150 % of outdoor unit capacity		
	Model / Quantity	P15~P250 / 1~30		
Sound pressure level (measured in anechoic room)		dB <A>	59	
Refrigerant piping diameter	High pressure	mm (in.)	19.05(3/4) Brazed	
	Low pressure	mm (in.)	28.58(1-1/8) Brazed	
FAN	Type x Quantity		Propeller fan x 1	
	Air flow rate	m ³ / min	225	
		L/s	3,750	
		cfm	7,945	
	Control, Driving mechanism		Inverter-control, Direct-driven by motor	
	Motor output	kW	0.92 x 1	
*3	External static press.	0 Pa (0 mmH ₂ O)		
Compressor	Type x Quantity		Inverter scroll hermetic compressor	
	Manufacture		AC&R Works, MITSUBISHI ELECTRIC CORPORATION	
	Starting method		Inverter	
	Motor output	kW	7.8	
	Case heater	kW	0.045(240 V)	
	Lubricant		MEL32	
External finish		Pre-coated galvanized steel sheets (+powder coating for -BS type) <MUNSELL 5Y 8/1>		
External dimension HxWxD		mm	1,710(1,650 without legs) x 1,220 x 760	
		in.	67-3/8(65 without legs) x 48-1/16 x 29-15/16	
Protection devices	High pressure protection		High pressure sensor, High pressure switch at 4.15,3.6MPa (601,522 psi)	
	Inverter circuit (COMP. / FAN)		Over-heat protection, Over-current protection	
	Compressor		Discharge thermo protection, Over-current protection	
	Fan motor		Thermal switch	
Refrigerant	Type x original charge		R410A x 11.8kg (27lbs)	
	Control		Indoor LEV and BC controller	
Net weight		kg (lbs)	290(640)	
Heat exchanger		Salt-resistant cross fin & copper tube		
HIC circuit (HIC: Heat Inter-Changer)		-		
Defrosting method		Auto-defrost mode (Reversed refrigerant cycle)		
Drawing	External		KD94G728	
	Wiring		KE94C491	
Standard attachment	Document		Installation Manual	
	Accessory		Refrigerant conn. pipe	
Optional parts		Joint: CMY-R160-J1 BC controller: CMB-P104,105,106,108,1010,1013,1016V-G1 Main BC controller: CMB-P108,1010,1013,1016V-GA1 Sub BC controller: CMB-P104,108V-GB1,CMB-P1016V-HB1		
Remarks		<ul style="list-style-type: none"> •Details on foundation work, duct work, insulation work, electrical wiring, power source switch, and other items shall be referred to the Installation Manual. •Due to continuing improvement, above specifications may be subject to change without notice. •Our company is unable to guarantee reliability of pre-existing pipes and pre-existing cables. 		

Notes:

- Nominal cooling conditions (subject to JIS B8615-1)
Indoor: 27°CDB/19°CWB (81°FDB/66°FWB), Outdoor: 35°CDB (95°FDB)
Pipe length: 7.5 m (24-9/16 ft.), Level difference: 0 m (0 ft.)
- Nominal heating conditions (subject to JIS B8615-1)
Indoor: 20°CDB (68°FDB), Outdoor: 7°CDB/6°CWB (45°FDB/43°FWB)
Pipe length: 7.5 m (24-9/16 ft.), Level difference: 0 m (0 ft.)
- External static pressure option is available (30 Pa, 60 Pa/3.1 mmH₂O, 6.1 mmH₂O).

Unit converter

kcal	=kW x 860
BTU/h	=kW x 3,412
cfm	=m ³ /min x 35.31
lbs	=kg / 0.4536

*The specification data is subject to rounding variation.

2. EXTERNAL DIMENSIONS

PURY-RP200, 250, 300YJM-B-(BS)

Unit : mm

- <Accessories>
 ● Connecting pipe <Low pressure> • Pipe (ID ϕ 25.4 × ID ϕ 28.58) 1 pc.

Note 1. Please refer to the next page for information regarding necessary spacing around the unit and foundation work.
 2. The detachable leg can be removed at site.
 3. At brazing of pipes, wrap the refrigerant service valve with wet cloth and keep the temperature of refrigerant service valve under 120°C.

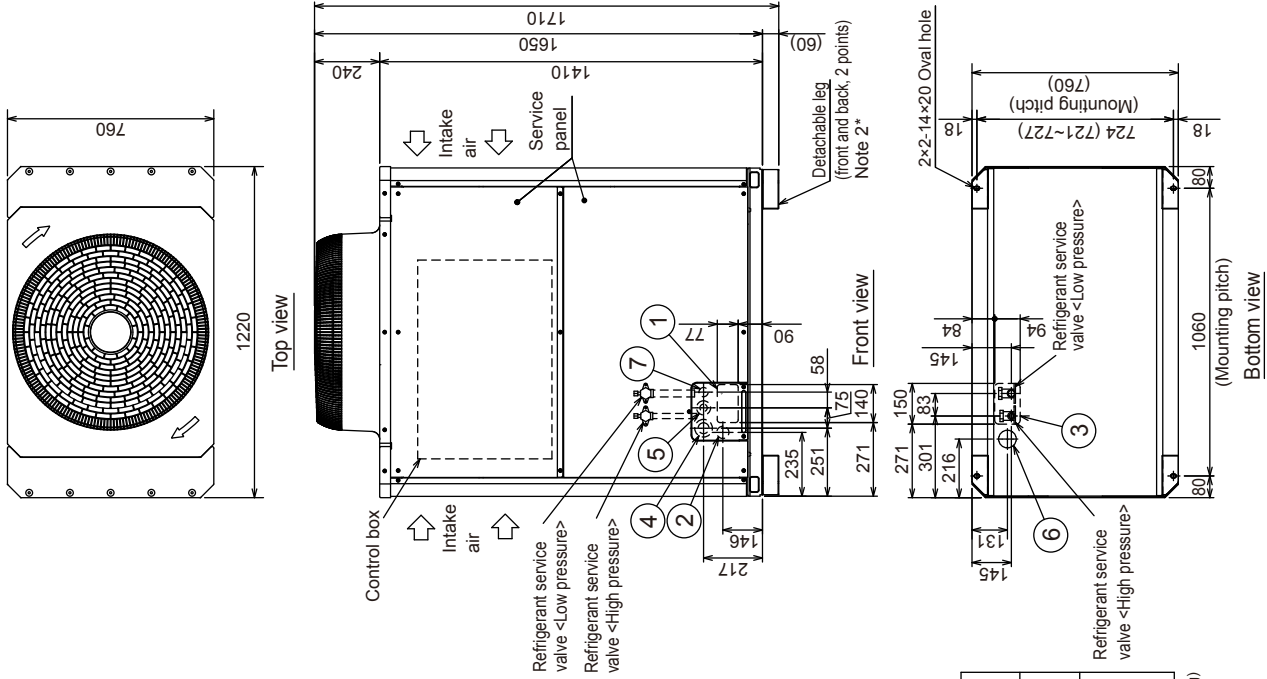

NO.	Usage	Specifications
①	Front through hole	140×77 Knockout hole
②	For pipes	Front through hole (Uses when twinning kit (optional parts) is mounted.)
③		Bottom through hole
④	For wires	150×94 Knockout hole
⑤		Front through hole
⑥		Front through hole
⑦	For transmission cables	Bottom through hole
		Front through hole

Model	Position dimensions for the refrigerant service valve *1		Connection specifications for the refrigerant service valve *1	
	High pressure A	Low pressure B	High pressure	Low pressure
PURY-RP200YJM-B-(BS)	261	263	High pressure	Low pressure
PURY-RP250YJM-B-(BS)			High pressure	Low pressure
PURY-RP300YJM-B-(BS)			High pressure	Low pressure

*1. Connect by using the connecting pipes (for bottom piping and front piping) that are supplied.

2. EXTERNAL DIMENSIONS

PURY-RP200, 250, 300YJM-B(-BS)

Unit : mm

1. Required space around the unit

● In case of single installation

- Secure enough space around the unit as shown in the figure below.
 - With a space of at least 300 mm to the wall on the back of the unit

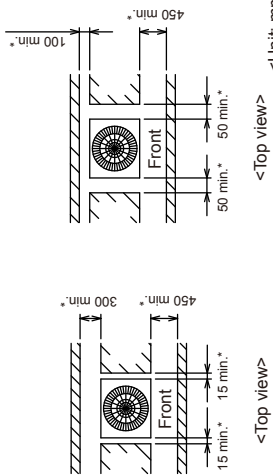

● In case of collective installation

- When multiple units are installed adjacent to each other, secure enough space to allow for air circulation and walkway between groups of units as shown in the figures below.
 - At least two sides must be left open.
 - As with the single installation, add the height that exceeds the height limit <h> to the figures that are marked with an asterisk.
 - If there is a wall at both the front and the rear of the unit, install up to six units consecutively in the side direction and provide a space of 1000 mm or more as inlet space/ passage space for each six units.

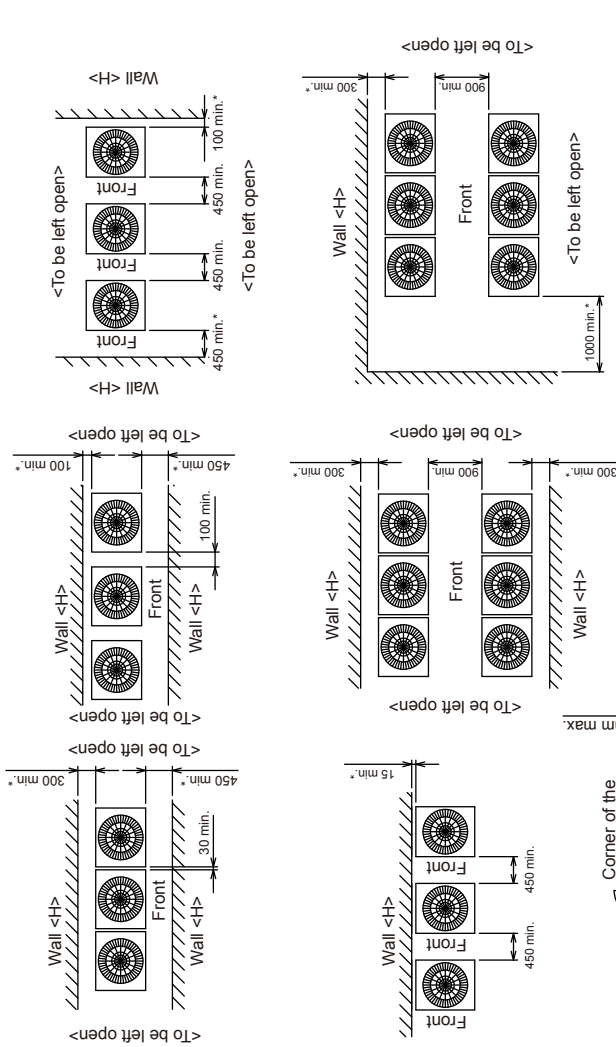

- When the height of the walls on the front, back or on the sides <H> exceeds the wall height limit as defined below, add the height that exceeds the height limit <h> to the figures that are marked with an asterisk.
 - Front: Up to the unit height
 - Back: Up to 500 mm from the unit bottom
 - Side: Up to the unit height

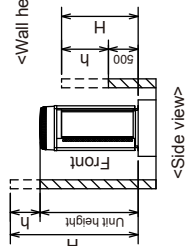

2. Foundation work

- Take into consideration the surface strength, water drainage route, piping route, and wiring route when preparing the installation site.
 - Note that the drain water comes out of the unit during operation.
- Build the foundation in such way that the corner of the installation leg is securely supported as shown in the right figure. (Fig.A, B)
 - When using a rubber isolating cushion, please ensure it is large enough to cover the entire width of each of the unit's legs.
- The protrusion length of the anchor bolt must not exceed 30 mm. (Fig.A, B)
- Use four fixing plates as shown in the right figure <field supply required> when using post-installed anchor bolts. (Fig.C, D)
 - To prevent small animals and water and snow from entering the unit and damaging its parts, close the gap around the edges of through holes for pipes and wires with filler plates <field supply required>.
- When the pipes or cables are routed at the bottom of the unit, make sure that the through hole at the base of the unit does not get blocked with the installation base.
- Refer to the Installation Manual when installing units on an installation base.

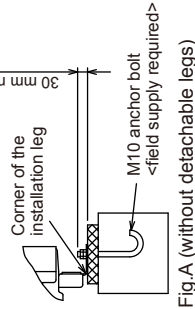

Fig.A (without detachable legs)

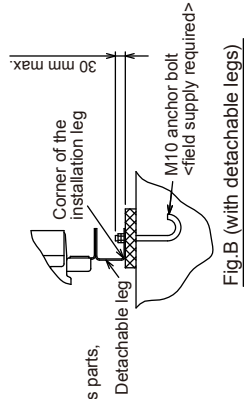

Fig.B (with detachable legs)

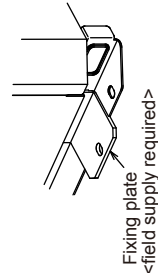

Fig.C (without detachable legs)

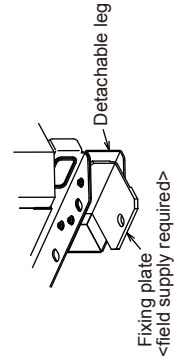
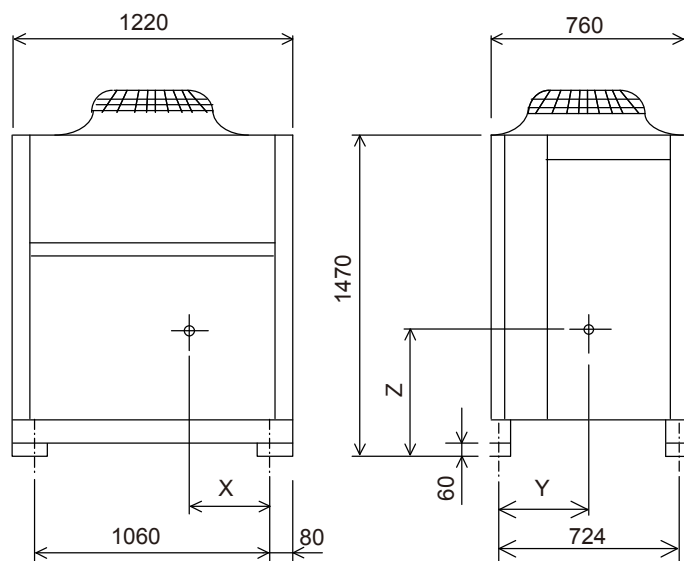

Fig.D (with detachable legs)

3. CENTER OF GRAVITY

PURY-RP200, RP250, RP300YJM-B(-BS)



Unit: mm

Model	X	Y	Z
PURY-RP200YJM-B(-BS)	445	342	642
PURY-RP250, 300YJM-B(-BS)	443	333	633

4. ELECTRICAL WIRING DIAGRAMS

PURY-RP200, 250, 300YJM-B(-BS)

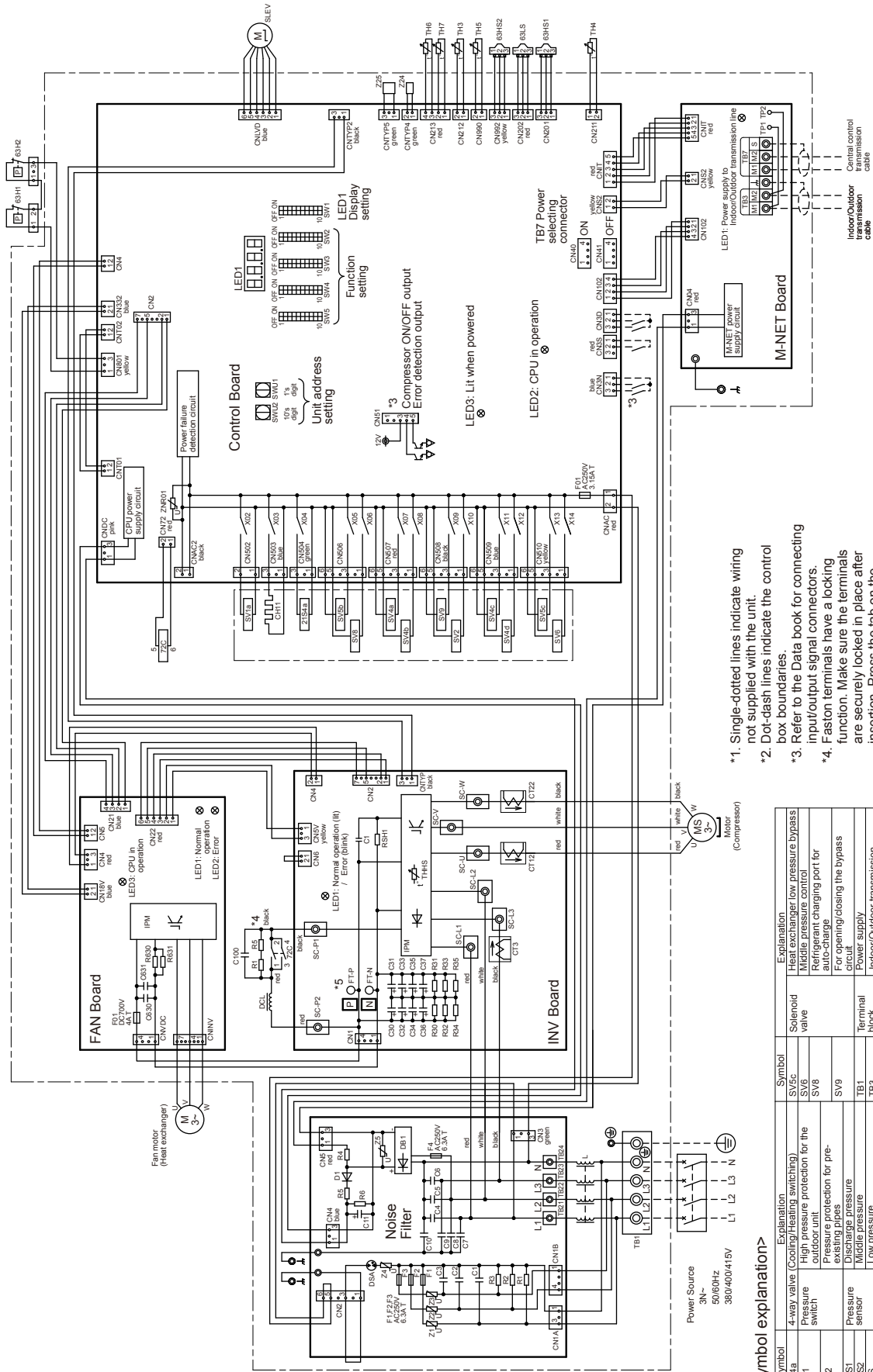

- *1. Single-dotted lines indicate wiring not supplied with the unit.
- *2. Dot-dash lines indicate the control box boundaries.
- *3. Refer to the Data book for connecting input/output signal connectors.
- *4. Fan terminals have a locking function. Make sure the terminals are securely locked in place after insertion. Press the tab on the terminals to remove them.
- *5. Control box houses high-voltage parts. Before inspecting the inside of the control box, turn off the power, keep the unit off for at least 10 minutes, and confirm that the voltage between F-T-P and F-T-N on INV Board has dropped to DC20V or less.

<Symbol explanation>

Symbol	Explanation	Symbol	Explanation
Z1S4a	4-way valve (Coating/heating switching)	SV5c	High exchanger/low pressure bypass
63H1	Pressure switch	SV6	Middle pressure control
63H2	Pressure sensor	SV9	Refrigerant charging port for auto-charge
63HS1	Discharge pressure	SV9	For opening/closing the bypass circuit
63HS2	Middle pressure	TB1	Power supply
63LS	Low pressure	TB3	Indoor/Outdoor transmission cable
Z2C	Magnetic relay (inverter main circuit)	TB7	Central control transmission cable
CH11	Current sensor (AC)	TH3	Liquid pipe temperature
DC1	Crankcase heater (for heating the compressor)	TH4	Discharge pipe temperature
SLEV	Oil flow control	TH5	Discharge pipe temperature
SV1a	Solenoid valve	TH6	Low pressure refrigerant pipe temperature
SV2	DC reactor	TH7	OA temperature
SV4a, b, c, d	For opening/closing the bypass	TH8	IPM temperature
SV5b	Heat exchanger capacity control	Z24, 25	Function setting connector
	For opening/closing the bypass circuit		

5. SOUND LEVELS

Measurement condition PURY-RP200, 250, 300YJM-B(-BS)

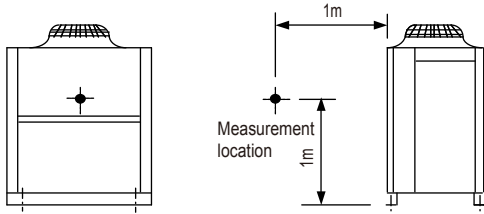

Sound level of PURY-RP300YJM-B(-BS)

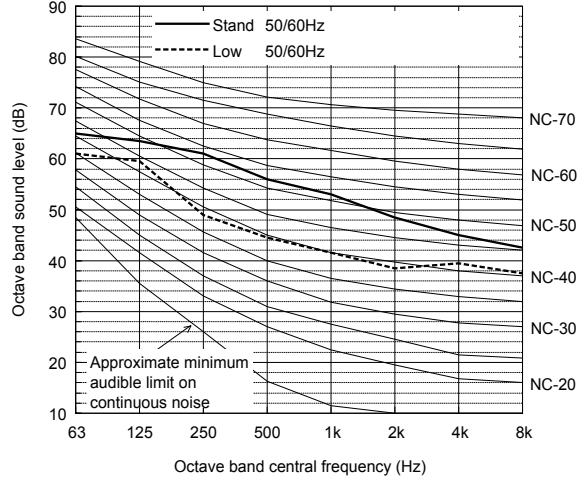

		63	125	250	500	1k	2k	4k	8k	dB(A)
Standard	50/60Hz	65.0	63.5	61.0	56.0	53.0	48.5	45.0	42.5	59.0
Low noise mode	50/60Hz	61.0	59.5	49.0	44.5	41.5	38.5	39.5	37.5	50.0

When Low noise mode is set, the A/C system's capacity is limited. The system could return to normal operation from Low noise mode automatically in the case that the operation condition is severe.

Sound level of PURY-RP200YJM-B(-BS)

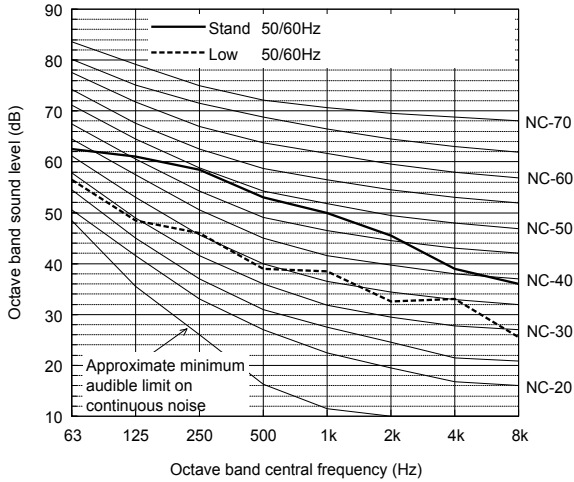

		63	125	250	500	1k	2k	4k	8k	dB(A)
Standard	50/60Hz	62.5	61.0	58.5	53.0	50.0	45.5	39.0	36.0	56.0
Low noise mode	50/60Hz	56.5	48.5	46.0	39.0	38.5	32.5	33.0	25.5	44.0

When Low noise mode is set, the A/C system's capacity is limited. The system could return to normal operation from Low noise mode automatically in the case that the operation condition is severe.

Sound level of PURY-RP250YJM-B(-BS)

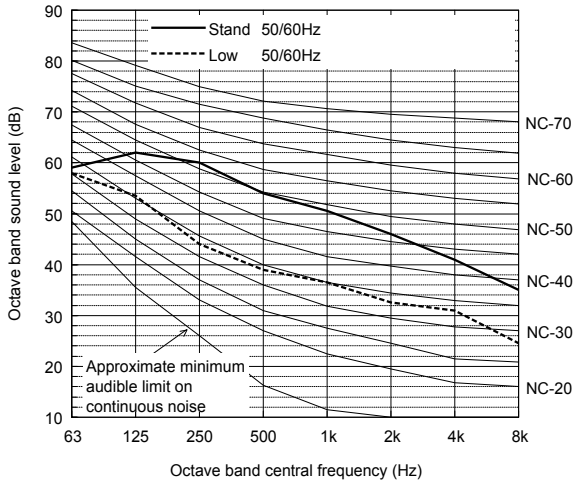

		63	125	250	500	1k	2k	4k	8k	dB(A)
Standard	50/60Hz	59.0	62.0	60.0	54.0	50.5	46.0	41.0	35.0	57.0
Low noise mode	50/60Hz	58.0	53.5	44.0	39.0	36.5	32.5	31.0	24.5	44.0

When Low noise mode is set, the A/C system's capacity is limited. The system could return to normal operation from Low noise mode automatically in the case that the operation condition is severe.

6. CAPACITY TABLES

6-1. Correction by temperature

CITY MULTI could have various capacities at different designing temperatures. Using the nominal cooling/heating capacity values and the ratios below, the capacity can be found for various temperatures.

PURY-		RP200YJM-B	RP250YJM-B
Nominal Cooling Capacity	kW	22.4	28.0
	BTU/h	76,400	95,500
Input	kW	4.95	6.82

PURY-		RP300YJM-B
Nominal Cooling Capacity	kW	33.5
	BTU/h	114,300
Input	kW	8.35

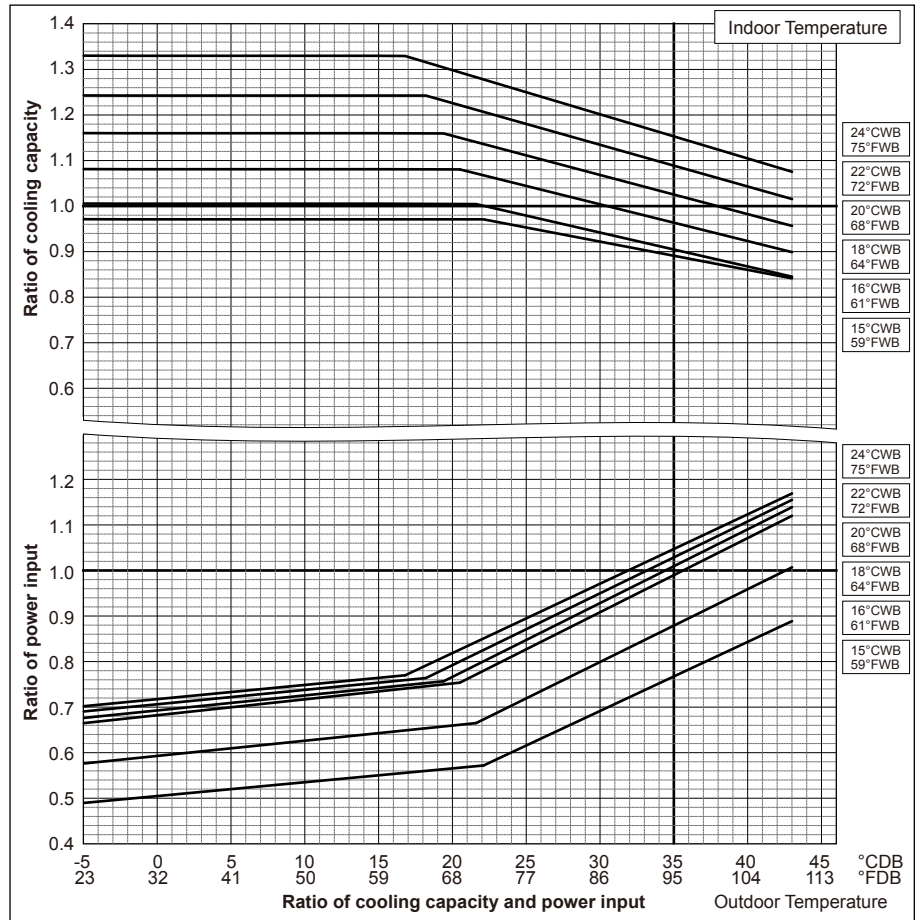

PURY-		RP200YJM-B	RP250YJM-B
Nominal Heating Capacity	kW	25.0	31.5
	BTU/h	85,300	107,500
Input	kW	5.50	7.22

PURY-		RP300YJM-B
Nominal Heating Capacity	kW	37.5
	BTU/h	128,000
Input	kW	8.70

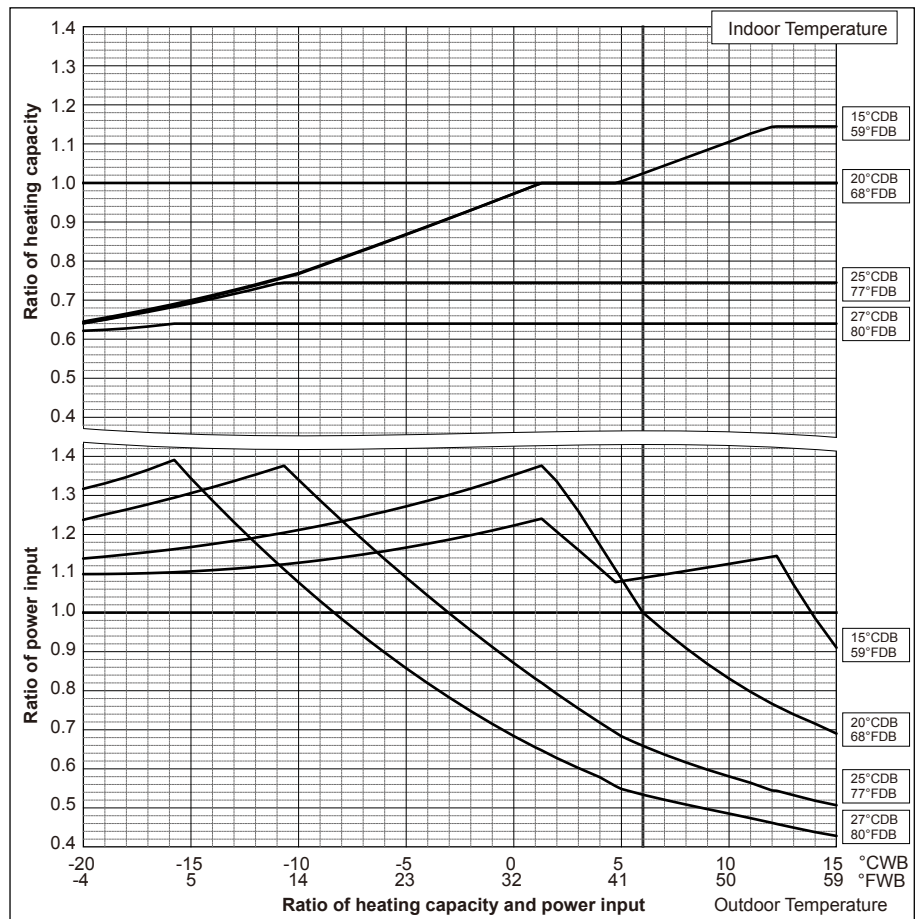

6. CAPACITY TABLES

Correction by temperature (COP Priority Mode)

CITY MULTI could have various capacities at different designing temperatures. Using the nominal cooling/heating capacity values and the ratios below, the capacity can be found for various temperatures.

To select high heating performance mode, DipSW 3-7 must be set to OFF.

PURY-		RP200YJM-B	RP250YJM-B
Nominal Cooling Capacity	kW	22.4	28.0
	BTU/h	76,400	95,500
Input	kW	4.95	6.82

PURY-		RP300YJM-B
Nominal Cooling Capacity	kW	33.5
	BTU/h	114,300
Input	kW	8.35

(There is no difference in cooling performance between Standard Mode and COP Priority Mode.)

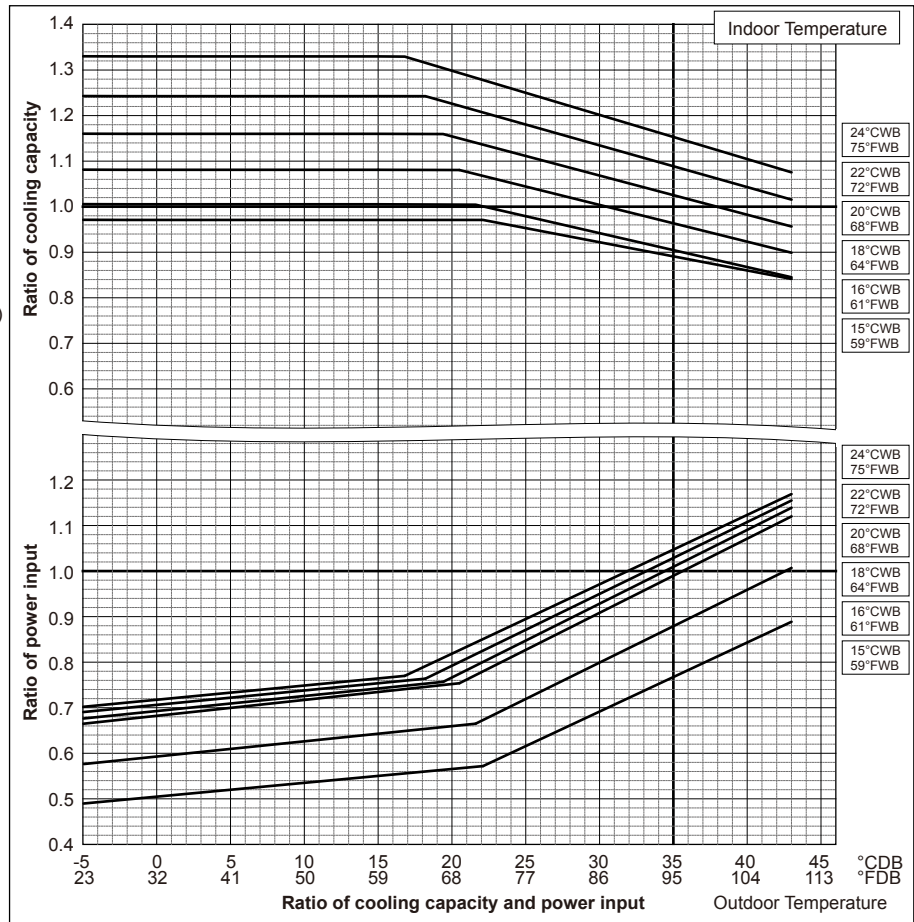

PURY-		RP200YJM-B	RP250YJM-B
Nominal Heating Capacity	kW	25.0	31.5
	BTU/h	85,300	107,500
Input	kW	5.50	7.22

PURY-		RP300YJM-B
Nominal Heating Capacity	kW	37.5
	BTU/h	128,000
Input	kW	8.70

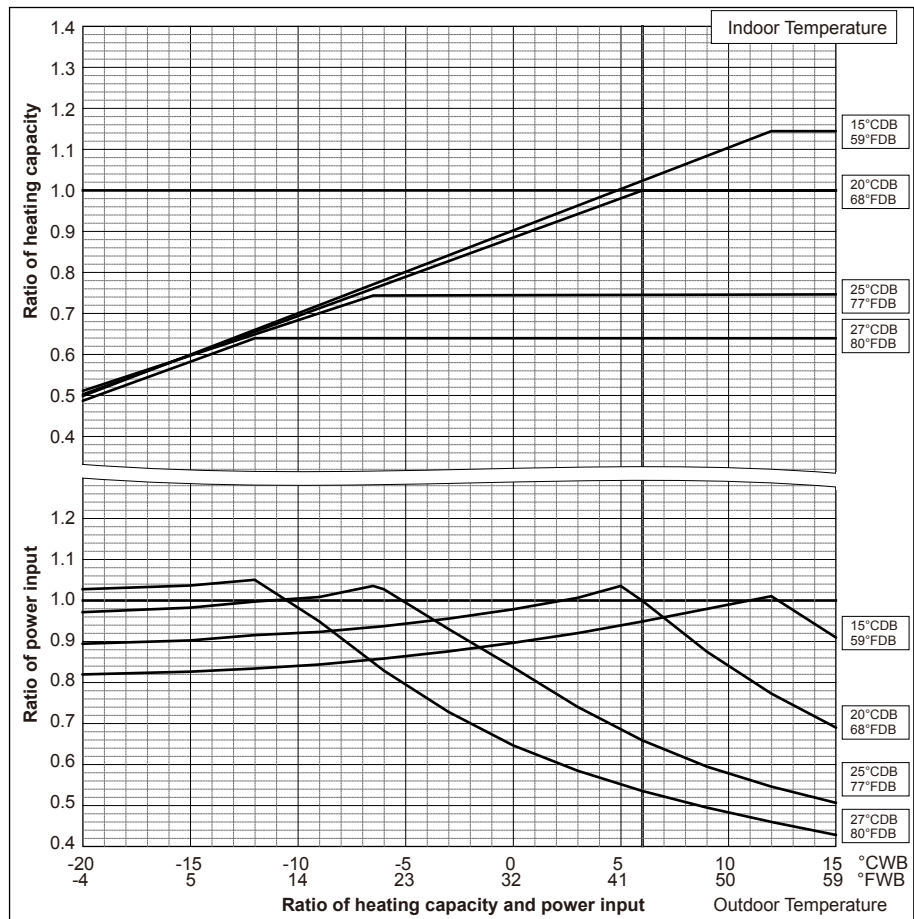

6. CAPACITY TABLES

Correction by temperature (Connection with PWFY-P100/200VM-E-AU (HEX unit))

PURY-		RP200YJM-B	RP250YJM-B
Nominal Cooling Capacity	kW	22.4	28.0
	BTU/h	76,400	95,500
Input	kW	4.95	6.82

PURY-		RP300YJM-B
Nominal Cooling Capacity	kW	33.5
	BTU/h	114,300
Input	kW	8.35

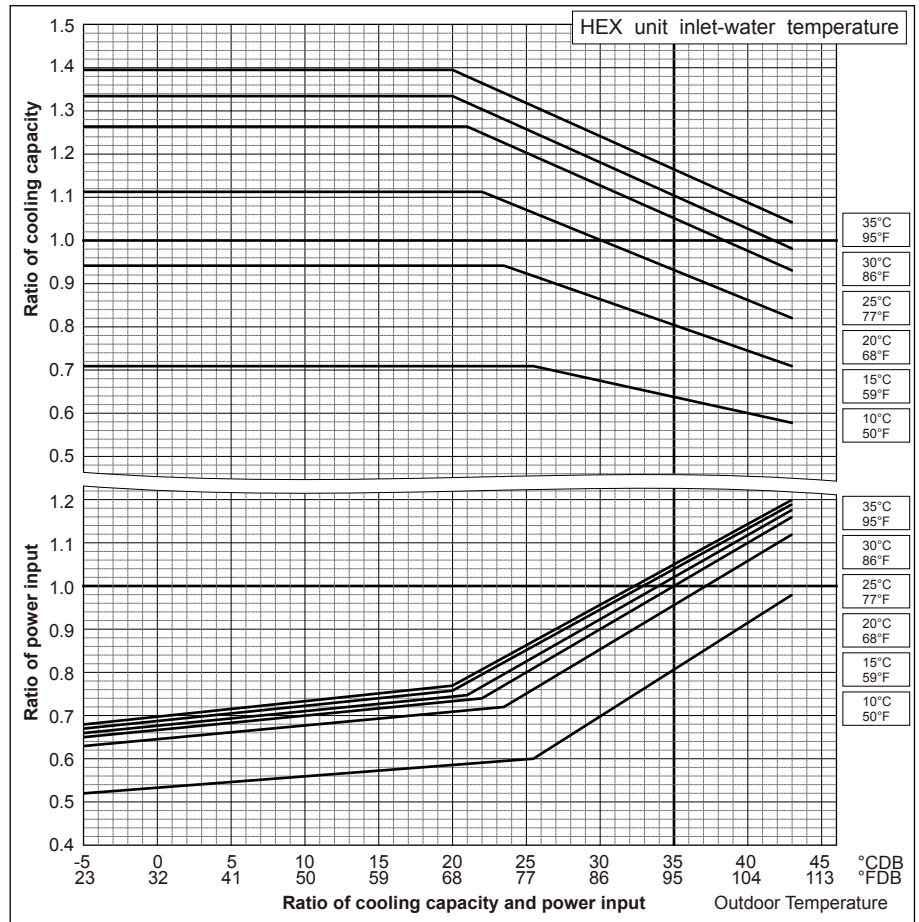

PURY-		RP200YJM-B	RP250YJM-B
Nominal Heating Capacity	kW	25.0	31.5
	BTU/h	85,300	107,500
Input	kW	5.50	7.22

PURY-		RP300YJM-B
Nominal Heating Capacity	kW	37.5
	BTU/h	128,000
Input	kW	8.70

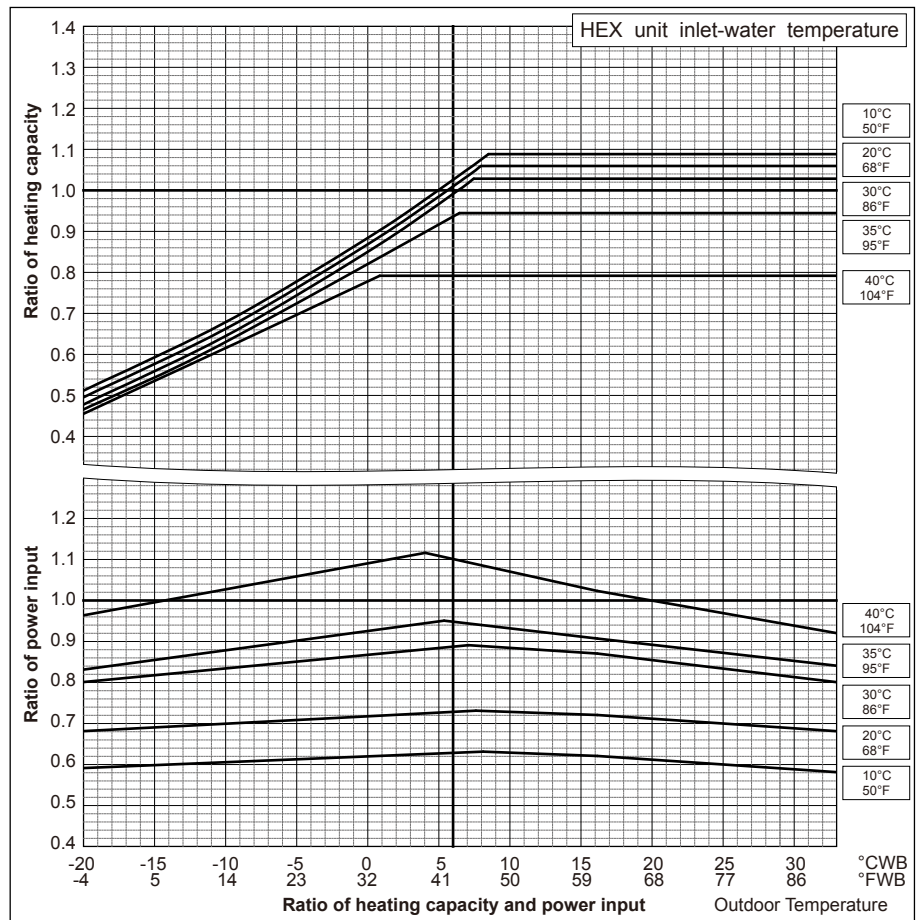

6. CAPACITY TABLES

Correction by temperature (Connection with PWFY-P100VM-E-BU (Booster unit))

PURY-		RP200YJM-B	RP250YJM-B
Nominal Heating Capacity	kW	25.0	31.5
	BTU/h	85,300	107,500
Input	kW	5.50	7.22

PURY-		RP300YJM-B
Nominal Heating Capacity	kW	37.5
	BTU/h	128,000
Input	kW	8.70

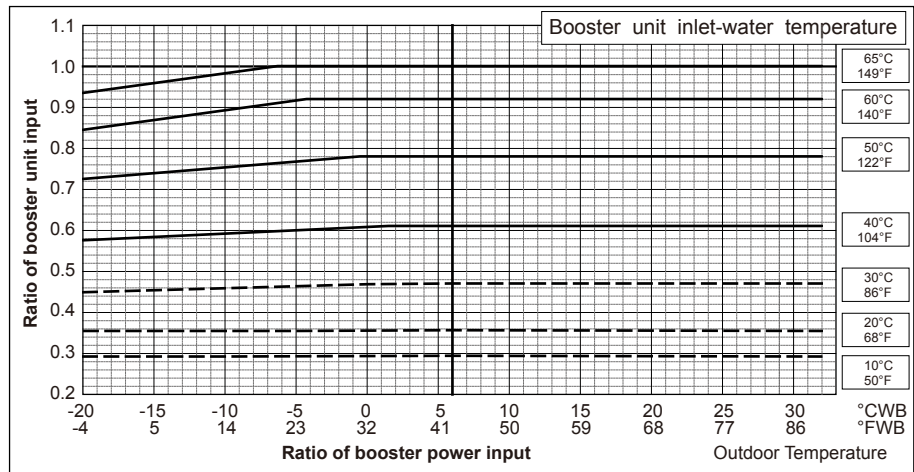
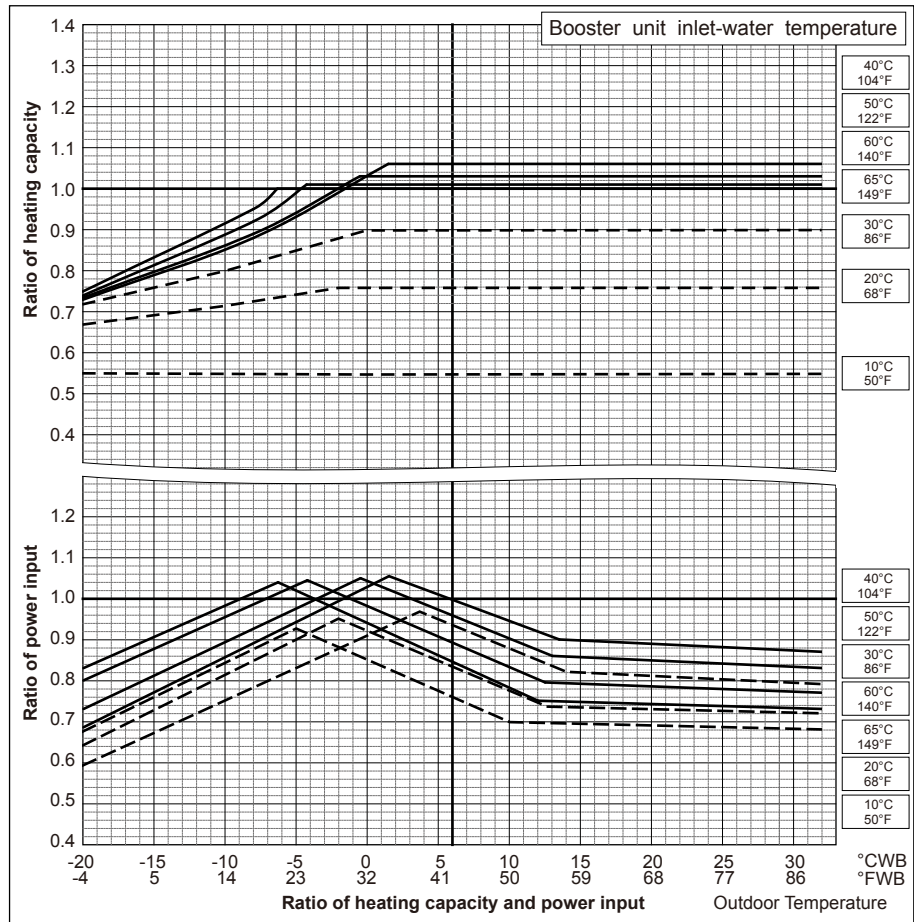

6. CAPACITY TABLES

6-2. Correction by total indoor

CITY MULTI system has different capacity and input at different total capacity of indoor unit connected. Using following tables, the maximum capacity can be observed so as to ensure the system having enough capacity to meet the conditions.

PURY-RP200, 250YJM-B(-BS)

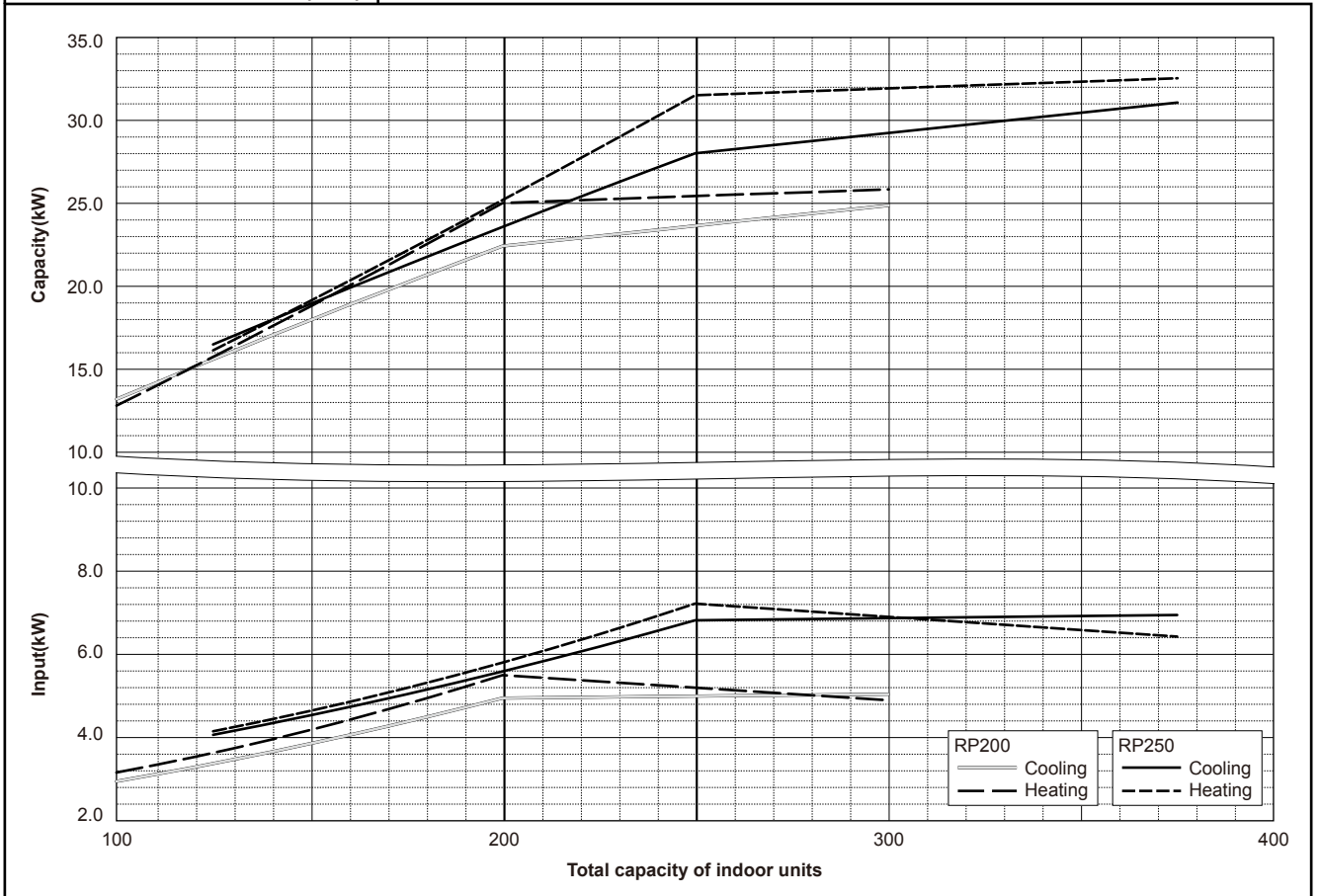

PURY-RP300YJM-B(-BS)

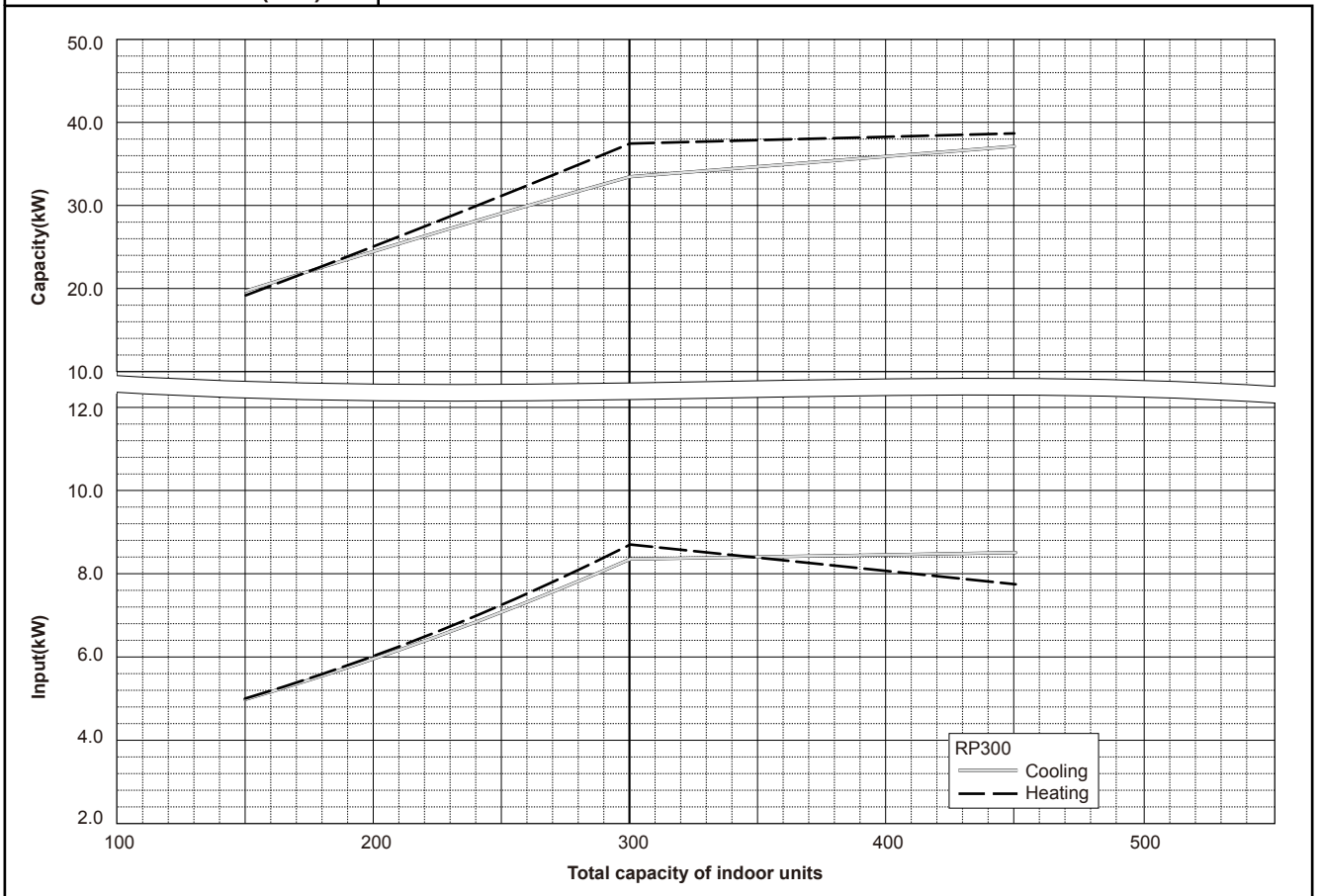

6. CAPACITY TABLES

6-3. Correction by refrigerant piping length

CITY MULTI system can extend the piping flexibly within its limitation for the actual situation. Yet, a decrease of cooling/heating capacity could happen correspondently. Using following correction factor according to the equivalent length of the piping shown at 6-3-1 and 6-3-2, the capacity can be observed. 6-3-3 shows how to obtain the equivalent length of piping.

6-3-1. Cooling capacity correction

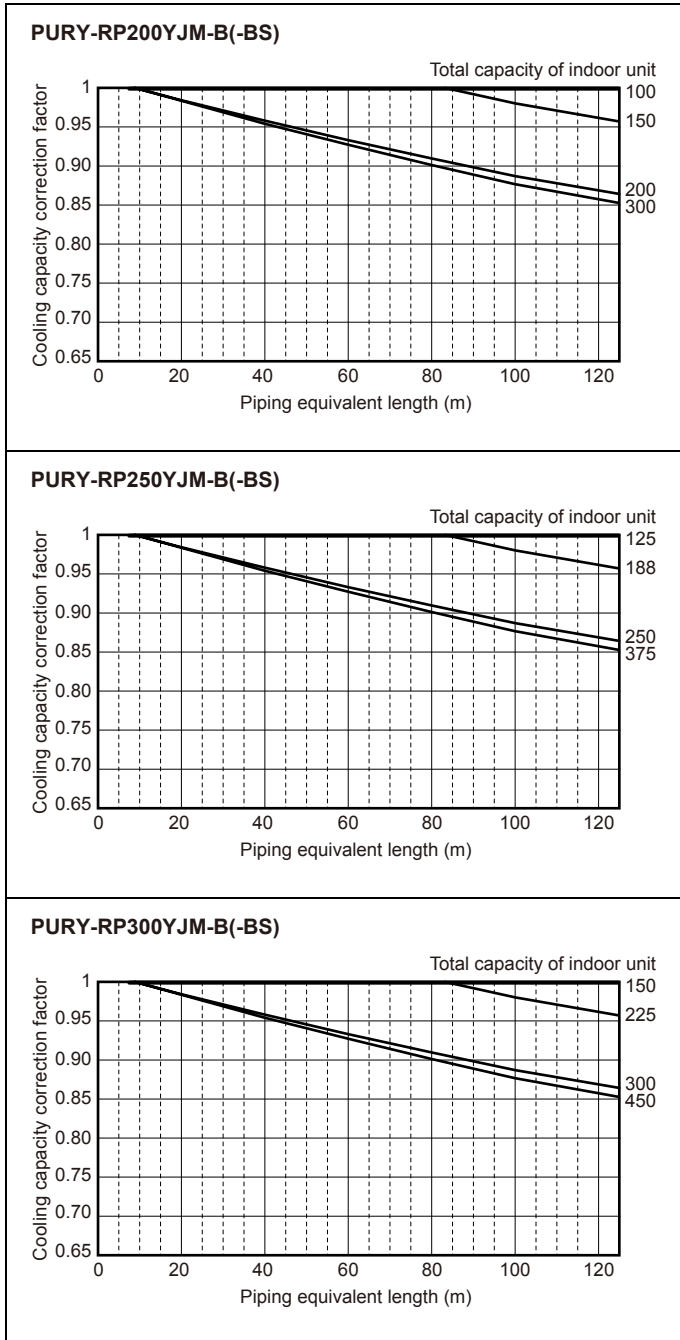

6. CAPACITY TABLES

6-3-2. Heating capacity correction

PURY-RP200YJM-B(-BS)

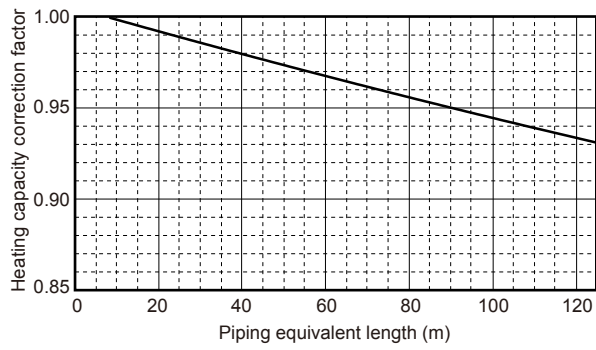

PURY-RP250YJM-B(-BS)

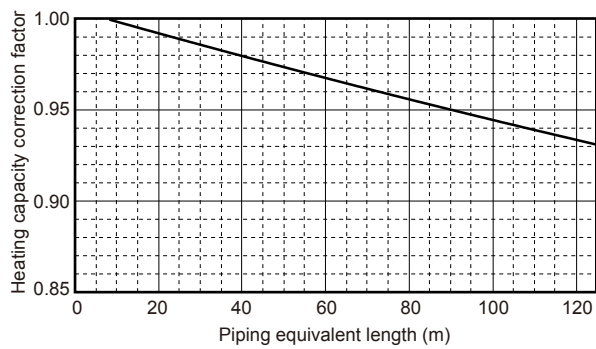

PURY-RP300YJM-B(-BS)

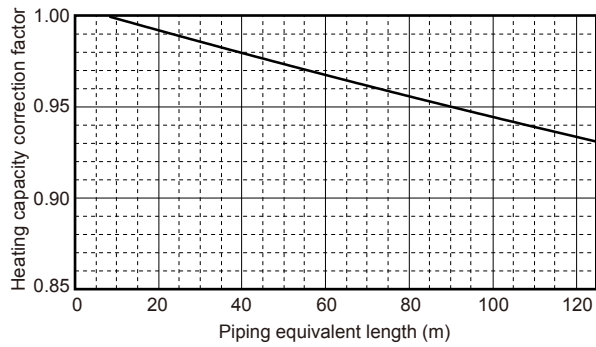

6. CAPACITY TABLES

6-3-3. How to obtain the equivalent piping length

1. PURY-RP200YJM-B(-BS)

Equivalent length = (Actual piping length to the farthest indoor unit) + (0.35 x number of bent on the piping) [m]

2. PURY-RP250, 300YJM-B(-BS)

Equivalent length = (Actual piping length to the farthest indoor unit) + (0.42 x number of bent on the piping) [m]

6-4. Correction by port counts of the BC controller

Indoor unit sizes P200 and P250 must be connected to 2 ports on the BC controller.

Indoor unit sizes from P100 to P140 should normally be connected to 2 ports on the BC controller (set BC controller DIP-SW 4-6 to its ON position).

In cases whereby indoor unit sizes from P100 to P140 are connected to only 1port on the BC controller (set BC controller DIP-SW 4-6 to its OFF position), the cooling capacity of the indoor unit should be multiplied by a correction factor of **0.97**.

6-5. Correction at frost and defrost

Due to frost at the outdoor heat exchanger and the automatic defrost operation, the heating capacity of the outdoor unit can be calculated by multiplying the correction factor shown in the table below.

Table of correction factor at frost and defrost

Outdoor inlet air temp. °C	6	4	2	1	0	-2	-4	-6	-8	-10	-20
Outdoor inlet air temp. °F	43	39	36	34	32	28	25	21	18	14	-4
PURY-RP200YJM-B(-BS)	1.00	0.95	0.84	0.83	0.83	0.87	0.90	0.95	0.95	0.95	0.95
PURY-RP250YJM-B(-BS)	1.00	0.95	0.84	0.83	0.83	0.87	0.90	0.95	0.95	0.95	0.95
PURY-RP300YJM-B(-BS)	1.00	0.93	0.82	0.80	0.82	0.86	0.90	0.90	0.95	0.95	0.95

6. CAPACITY TABLES

6-6. Operation temperature range

• Cooling

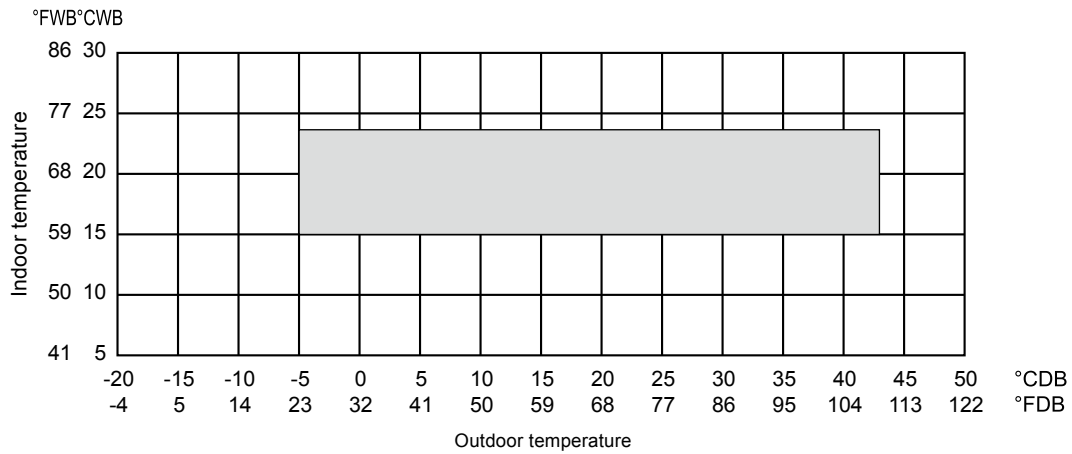

• Heating

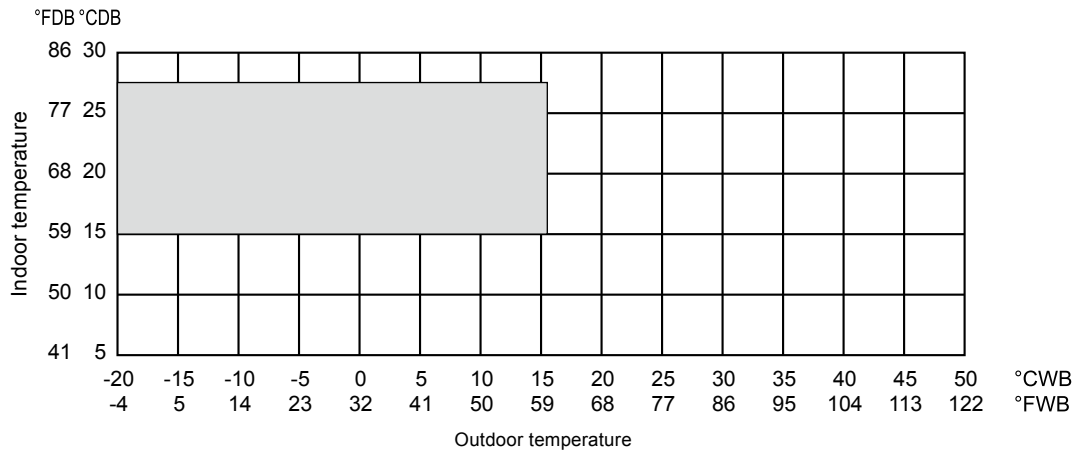

• Combination of cooling/heating operation (Cooling main or Heating main)

Outdoor temperature	Indoor temperature	
	Cooling	Heating
-5 to 21°CDB (23 to 70°FDB)	—	15 to 27°CDB (59 to 81°FDB)
-6 to 15.5°CWB (21 to 60°FWB)	15 to 24°CWB (59 to 75°FWB)	—

7. UNIT SELECTION

7-1. Indoor and outdoor unit selection

(1) Selecting indoor units

- 1) Calculate the thermal load of each room.
- 2) Based on the thermal load corrected for indoor unit return air temperature, select appropriate indoor unit models. Refer to the correction factor diagram for the outdoor unit whose capacity is the closest to the total thermal load of the system (Q_i). Refer to "CAPACITY TABLES (Indoor unit)" and "6. CAPACITY TABLES."
- 3) Calculate the total capacity of the indoor units in the system (N).

(2) Selecting outdoor units

- 1) Based on the total capacity of the indoor units (N), tentatively select the capacity of the outdoor unit (X).
The total capacity of the indoor units to be connected to a given outdoor unit (N) should not exceed the maximum connectable capacity of the outdoor unit.
- 2) The tentatively selected standard capacity of the outdoor unit (X) will be defined as Q_s .
* If the total capacity of the indoor units that are connected to a given outdoor unit exceeds 100% of the outdoor unit capacity (X), refer to the outdoor unit partial load capacity table, find the capacity that corresponds to the total capacity N , and use it as the standard outdoor unit capacity (Q_s).
- 3) Obtain the maximum outdoor unit capacity (Q_m) by multiplying Q_s (standard outdoor unit capacity) by the following correction factors: piping length, outside air temperature, and defrost (heating).
Find the piping length correction factor from the diagram that corresponds to the total indoor unit capacity (N).

$$Q_m = Q_s \times \text{Piping length correction factor} \times \text{Outside air temperature correction factor} \\ \times \text{Defrost correction factor (heating only)} \times \text{Pipe diameter correction factor}$$

Outside air temperature correction factor	Refer to 6-1.
Piping length correction factor	Refer to 6-3.
Defrost correction factor (heating only)	Refer to 6-5.
Pipe diameter correction factor (applicable only if non-standard size pipes are connected)	Refer to 7-3.

- 4) Make sure the maximum outdoor unit capacity Q_m is equal to or greater than the total thermal load Q_i .
If Q_m is smaller than Q_i , reconsider the outdoor unit capacity (X) so that $Q_m \geq Q_i$ will hold true.
- 5) After selecting indoor and outdoor units, calculate the apportioned indoor unit capacity, and make sure that the formula "Thermal load \leq Indoor unit capacity" will hold true for each room.
If the thermal load exceeds the indoor unit capacity in one or more rooms, increase the indoor unit size as long as doing so will not exceed the maximum connectable capacity of the outdoor unit. Then, start over from step 1) above. If the maximum connectable capacity is exceeded by increasing the indoor unit capacity, increase the outdoor capacity as well, then start over from step 1) above.

Calculate the indoor/outdoor unit capacities and check for unit compatibility by considering both the heating and the cooling loads. If the formula $Q_m \geq Q_i$ does not hold true for either cooling or heating, reconsider the outdoor unit capacity (X).

7. UNIT SELECTION

(3) Obtaining the unit capacity

- A. If the apportioned indoor unit capacity obtained in step 5) on the previous page is equal to or greater than the rated indoor unit capacity, the following formula will be used to calculate the indoor unit capacity: "Rated capacity x return air temperature correction factor x piping length correction factor (x pipe diameter correction factor)".
- B. If the apportioned indoor unit capacity obtained in step 5) on the previous page is smaller than the rated indoor unit capacity, the following formula will be used to calculate the indoor unit capacity: "Apportioned indoor unit capacity x return air temperature correction factor."
- * The standard outside air temperatures used to obtain the return air temperature correction factor is 35°CDB for cooling and 6°CWB for heating.
- * If non-standard size pipes are connected, use the pipe diameter correction factors for the main pipes, merge pipes, and branch pipes.

(4) Notes

When deciding the outside air temperature to calculate unit capacity requirements, take into consideration the possible temperature rise around the outdoor unit due to short-cycling. (When installing outdoor units collectively on the rooftop or if outdoor units are surrounded by walls or other objects, it is recommended to set the outside temperature as 43°C for calculation.)

If you want to take sensible heat load into consideration, refer to the relevant catalogs for information on sensible heat factor when selecting indoor units.

7. UNIT SELECTION

7-2. Calculation samples

(1) To connect indoor units using the standard pipes

Design conditions

<Cooling> Indoor design dry-bulb temperature: 26°C/Indoor design wet-bulb temperature: 18.5°C
Outdoor design dry-bulb temperature: 36°C
Cooling load: 13.5 kW for each of the two rooms

<Heating> Indoor design dry-bulb temperature: 21°C
Outdoor design wet-bulb temperature: 5°C
Heating load: 14.5 kW for each of the two rooms

<Miscellaneous information>

Main piping: $\varnothing 28.58 \times 45$ m, Branch piping: $\varnothing 19.05 \times 5$ m (Equivalent indoor and outdoor piping length: 50 m)

A. Calculating the cooling load

- The thermal load (13.5 kW/room), indoor unit return air temperature correction factor, and piping length correction factor are used to calculate the required indoor unit capacity, based on which a 125 model of indoor unit is tentatively selected. (Because the total thermal load is 27 kW, the air temperature correction diagram for the 250 model outdoor unit will be used.)
- Because the total capacity of indoor units (N) is 250, the 250 model outdoor unit is tentatively selected. Based on the above, the standard capacity Q_s will be 28 kW.
- The correction values obtained from the air temperature correction factor graph and the piping length correction factor graph for the 250 model outdoor units are as follows:
Outside air temperature 36°CDB Capacity correction factor 0.99 (at the standard indoor wet-bulb temperature of 19°C)
Piping length: 50 m Capacity correction factor: 0.97
If the standard capacity Q_s is corrected for indoor/outside air temperatures and piping length, the maximum outdoor unit capacity Q_m can be obtained as follows: $Q_m = 28 \times 0.99 \times 0.97 = 26.8$ kW.
The result shows that the thermal load Q_i (27 kW) exceeds the unit capacity Q_m , so a larger 300 model outdoor unit needs to be selected.
- For the 300 model units, the outside air temperature correction factor is 0.99. The piping length correction factor that can be obtained from the diagram for the system whose total indoor unit capacity is 250 would be 0.96.
Because the standard outdoor unit capacity Q_s is 33.5 kW, the maximum outdoor unit capacity Q_m can be obtained using the following formula: $Q_m = 33.5 \times 0.99 \times 0.96 = 31.8$ kW. The result 31.8 kW is greater than the Q_i (27 kW), so the maximum capacity Q_m meets the capacity requirement.
- Compare the thermal loads on the indoor units, using the maximum outdoor unit capacity apportioned to each indoor unit and taking the indoor unit return air temperature correction factors into consideration. The correction factor for the return air temperature at 18.5°CWB is 0.99 (at the standard outside dry-bulb temperature of 35°C), and this value can be plugged into the following formula to obtain the capacity.
 $32.1 \text{ kW} \times 125/250 \times 0.99 = 15.8 \text{ kW}$
The result shows that the capacity (15.8 kW) is greater than the thermal load (13.5 kW), and based on this result, two 125 model indoor units and one 300 model outdoor unit can be selected.

B. Calculating the heating load

Next, you will calculate the heating load and unit capacity requirements, using the models that were selected in the previous section.

- The standard capacity (Q_s) of the tentatively selected 300 model outdoor unit is 37.5 kW.
- Use this value in the following formula to obtain the maximum outdoor unit capacity Q_m as shown below:
 $Q_m = 37.5 \times 1.00 \times 0.965 \times 0.975 = 35.2$ kW, (where the outside air temperature is 5°CWB, capacity correction factor is 1.00 (at the standard indoor dry-bulb temperature of 20°C), defrost correction factor is 0.965, piping length is 50 m, and capacity correction factor is 0.975).
The result shows that the Maximum outdoor unit capacity Q_m (35.2 kW) exceeds the heating load Q_i (29 kW).
- You can now check to see if this value will meet the capacity requirement for each indoor unit by using the following formula: $35.2 \times 125/250 \times 0.96 = 16.8$ kW (where the indoor unit return air temperature correction factor at 21°CDB is 0.96) (standard outside temperature at 6°C). The result shows that the unit capacity (16.8 kW) exceeds the thermal load for each room (14.5 kW).
Based on the above calculation, the following indoor and outdoor units can be selected.
Indoor units: 125 model $\times 2$ units
Outdoor unit: RP300 model

C. Calculating the capacity requirement

- The cooling capacity of the tentatively selected outdoor unit apportioned to each indoor unit is 15.8 kW, which exceeds the rated cooling capacity of the 125 model unit (14.0 kW). The actual cooling capacity under the specified conditions is calculated as follows: $14.0 \times 0.99 \times 0.97 = 13.4$ kW (where the return air temperature correction factor at the standard outside temperature of 35°CDB is 0.99 and the piping length correction factor is 0.97).
- The heating capacity of the tentatively selected outdoor unit apportioned to each indoor unit is 16.8 kW, which exceeds the rated cooling capacity of the 125 model unit (16.0 kW). The actual heating capacity under the specified conditions is calculated as follows: $16.0 \times 0.95 \times 0.975 = 14.8$ kW (where the return air temperature correction factor at the standard outside temperature of 6°CWB is 0.95 and the piping length correction factor is 0.975).

7. UNIT SELECTION

(2) To connect indoor units using non-standard pipes

Design conditions

<Cooling> Indoor design dry-bulb temperature: 26°C/Indoor design wet-bulb temperature: 18.5°C
Outdoor design dry-bulb temperature: 36°C
Cooling load: 13.5 kW for each of the two rooms

<Heating> Indoor design dry-bulb temperature: 21°C
Outdoor design wet-bulb temperature: 5°C
Heating load: 14.5 kW for each of the two rooms

<Miscellaneous information>

Main piping: $\varnothing 25.4 \times 45$ m, Branch piping: $\varnothing 15.88 \times 5$ m (Equivalent indoor and outdoor piping length: 50 m)

A. Calculating the cooling load

a) The thermal load of 13 kW per room and the indoor unit return air temperature correction factor are used to calculate the required indoor unit capacity, based on which a 125 model of indoor unit is tentatively selected. (Because the total thermal load is 26 kW, the air temperature correction diagram for the 250 model outdoor unit will be used.)

b) Because the total capacity of indoor units (N) is 250, the 250 model outdoor unit is tentatively selected.
Based on the above, the standard capacity Q_s will be 28 kW.

c) The correction values obtained from the air temperature correction factor graph and the piping length correction factor graph for the 250 model outdoor units are as follows:

Outside air temperature 36°CDB	Capacity correction factor 0.99 (at the standard indoor wet-bulb temperature of 19°C)
Piping length: 50 m	Capacity correction factor: 0.97
Main piping: $\varnothing 25.4 \times 45$ m	Pipe diameter correction factor: 0.98

The standard capacity Q_s is corrected for indoor/outside air temperatures, piping length, and pipe diameter to obtain the maximum outdoor unit capacity Q_m as follows: $Q_m = 28 \times 0.99 \times 0.97 \times 0.98 = 26.3$ kW. Because this value does not meet the thermal load Q_i (27 kW), a larger 300 model outdoor unit needs to be selected.

d) For the 300 model, the outside air temperature correction factor is 0.99, the pipe diameter correction factor for a 45 m pipe with a diameter of $\varnothing 25.4$ is 0.98, and the piping length correction factor is 0.96 (read from the diagram for the unit whose total indoor unit capacity N is 250).

Where the standard outdoor unit capacity Q_s is 33.5 kW, the maximum outdoor unit capacity Q_m can be obtained as follows: $Q_m = 33.5 \times 0.99 \times 0.98 \times 0.96 = 31.2$ kW. This value is greater than the thermal load Q_i (27 kW), and the maximum capacity Q_m satisfies the capacity requirements.

e) Compare the thermal loads on the indoor unit side, using the maximum outdoor unit capacity apportioned to each indoor unit and taking the indoor unit return air condition correction factors into consideration. The correction factor for the return air temperature at 18.5°C is 0.99 (at the standard outside dry-bulb temperature of 35°C), and the pipe diameter correction factor for a 5 m pipe with a diameter of $\varnothing 15.88$ connected to a 125-model unit is 0.99. These values can be plugged into the following formula to obtain the capacity.

$$31.8 \text{ kW} \times 125/250 \times 0.99 \times 0.99 = 15.5 \text{ kW}$$

The result shows that the capacity (15.5 kW) is greater than the thermal load of 13.5 kW, and based on this result, two 125 model indoor units and one 300 model outdoor unit can be selected.

B. Calculating the heating load

Next, we will calculate the heating load, using the models that are selected based on the cooling load calculation.

a) The standard capacity Q_s of the tentatively selected (during cooling load calculation) 300 model outdoor unit is 37.5 kW.

b) The correction values obtained from the air temperature correction factor graph and the piping length correction factor graph for the 300 model outdoor units are as follows:

Outside air temperature 5°CWB	Capacity correction factor 1.00 (at the standard indoor dry-bulb temperature of 20°C)
	Defrost correction factor is 0.975
Piping length: 50 m	Capacity correction factor: 0.975
Main piping: $\varnothing 25.4 \times 45$ m	Pipe diameter correction factor: 0.98

The standard capacity Q_s is corrected for indoor/outside air temperatures and piping length to obtain the maximum outdoor unit capacity Q_m as follows: $Q_m = 37.5 \times 1.00 \times 0.975 \times 0.975 \times 0.98 = 34.9$ kW.

The result shows that the Maximum outdoor unit capacity Q_m (34.9 kW) exceeds the heating load Q_i (29 kW).

c) You can now check to see if this value will meet the capacity requirement for each indoor unit by using the following formula: $34.9 \times 125/250 \times 0.96 \times 0.99 = 16.5$ kW (where the correction factor for the indoor unit return air temperature of 21°CDB is 0.96 (standard outside temperature at 6°C), and the pipe diameter correction factor for a 5 m branch pipe with a diameter of $\varnothing 15.88$ connected to a 125 models is 0.99. The result shows that the unit capacity 16.5 kW exceeds the thermal load for each room (14.5 kW).

Based on the above calculation, the following indoor and outdoor units can be selected.

Indoor units: 125 model x 2 units
Outdoor unit: RP300 model

7. UNIT SELECTION

<Capacity requirement calculation flow chart>

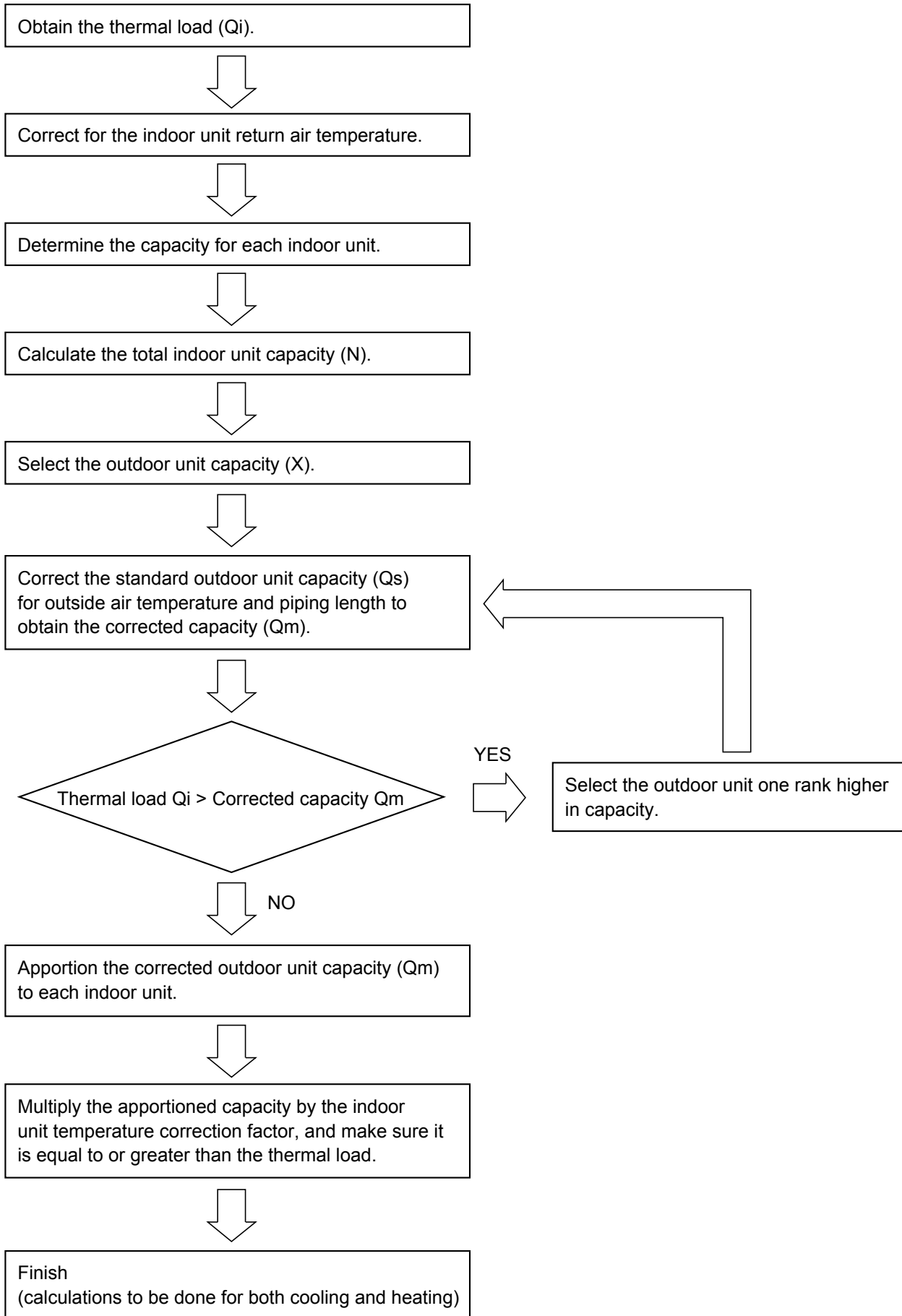

7. UNIT SELECTION

7-3. Pipe diameter correction factor

7-3-1. Correction factors for the outdoor units and main pipe diameter

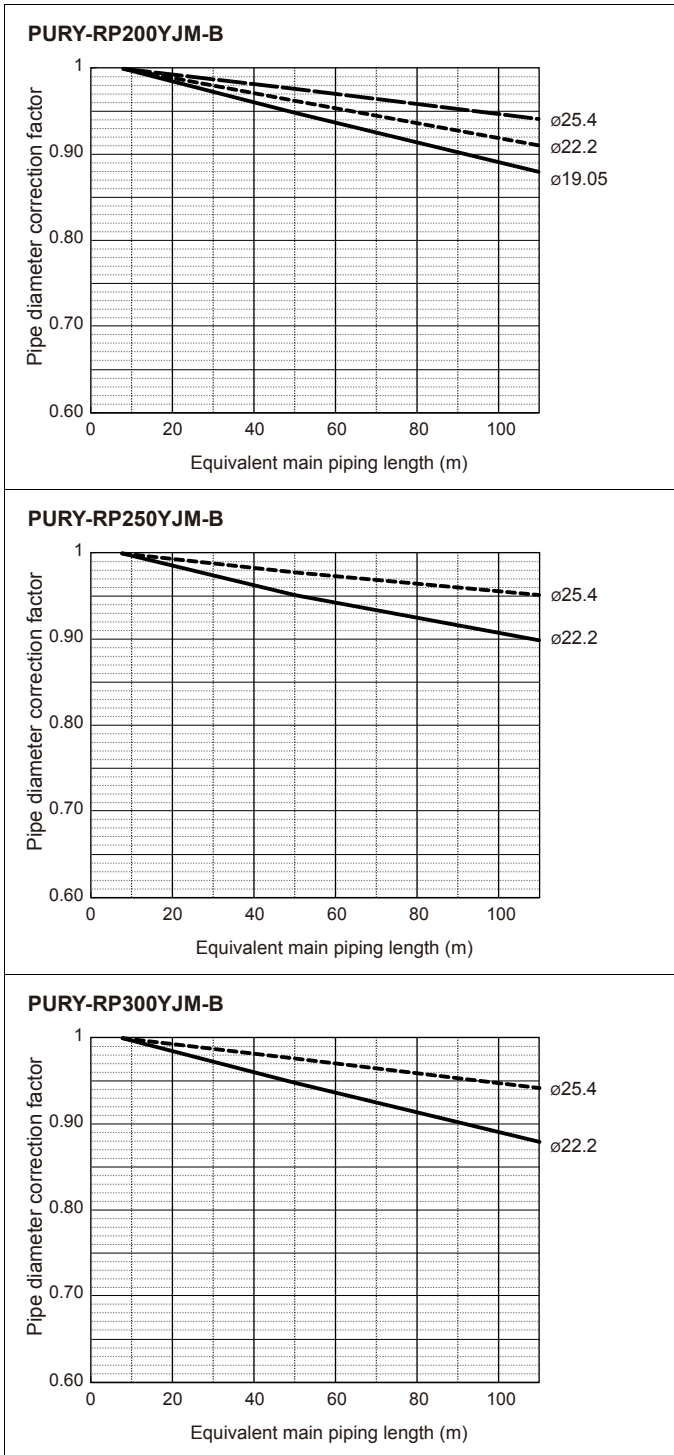

7. UNIT SELECTION

7-3-2. Correction factors for the indoor units and branch pipe diameter

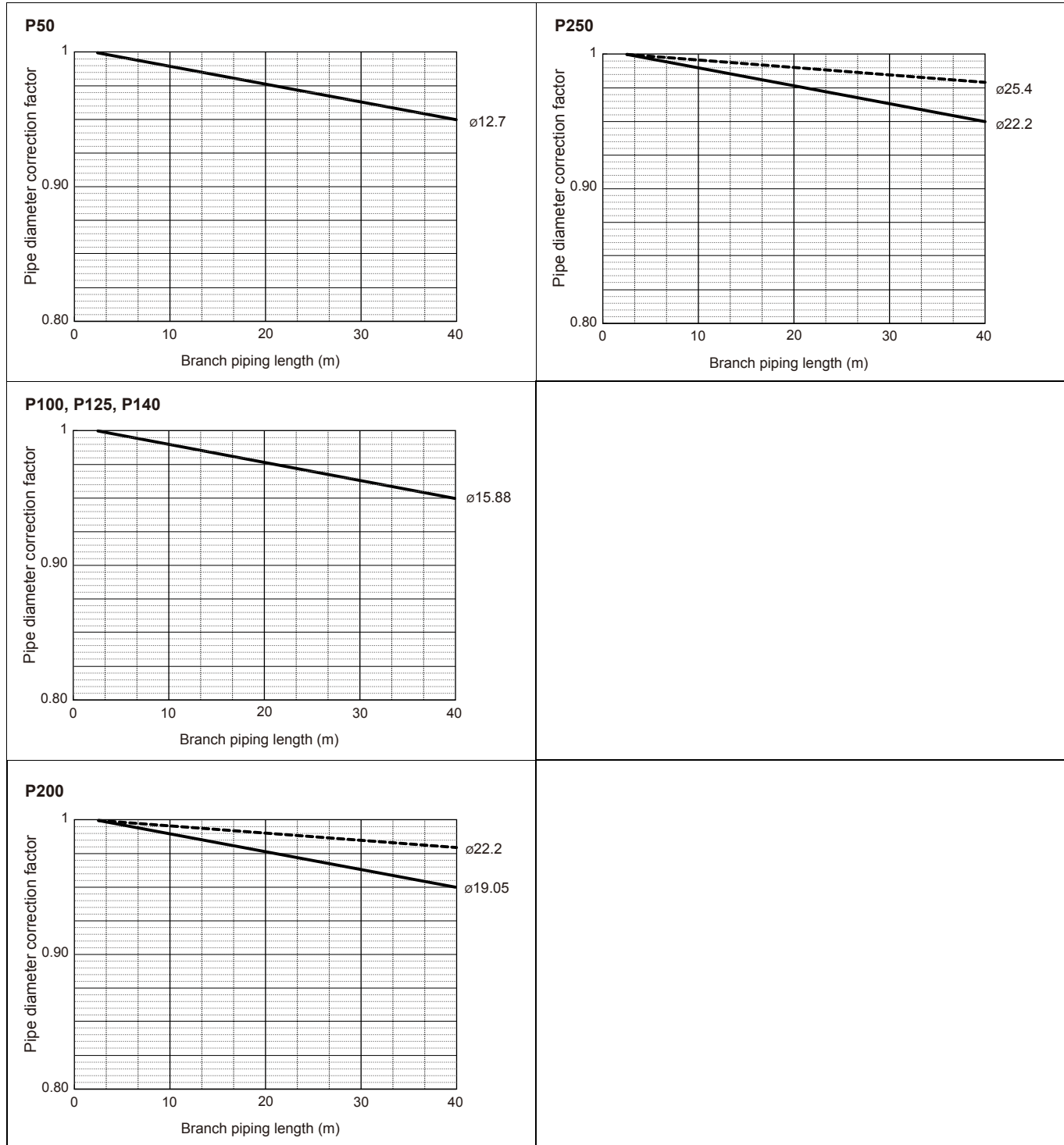

7. UNIT SELECTION

7-3-3. Correction factors for the downstream indoor units and the pipes at the downstream of the branch pipe

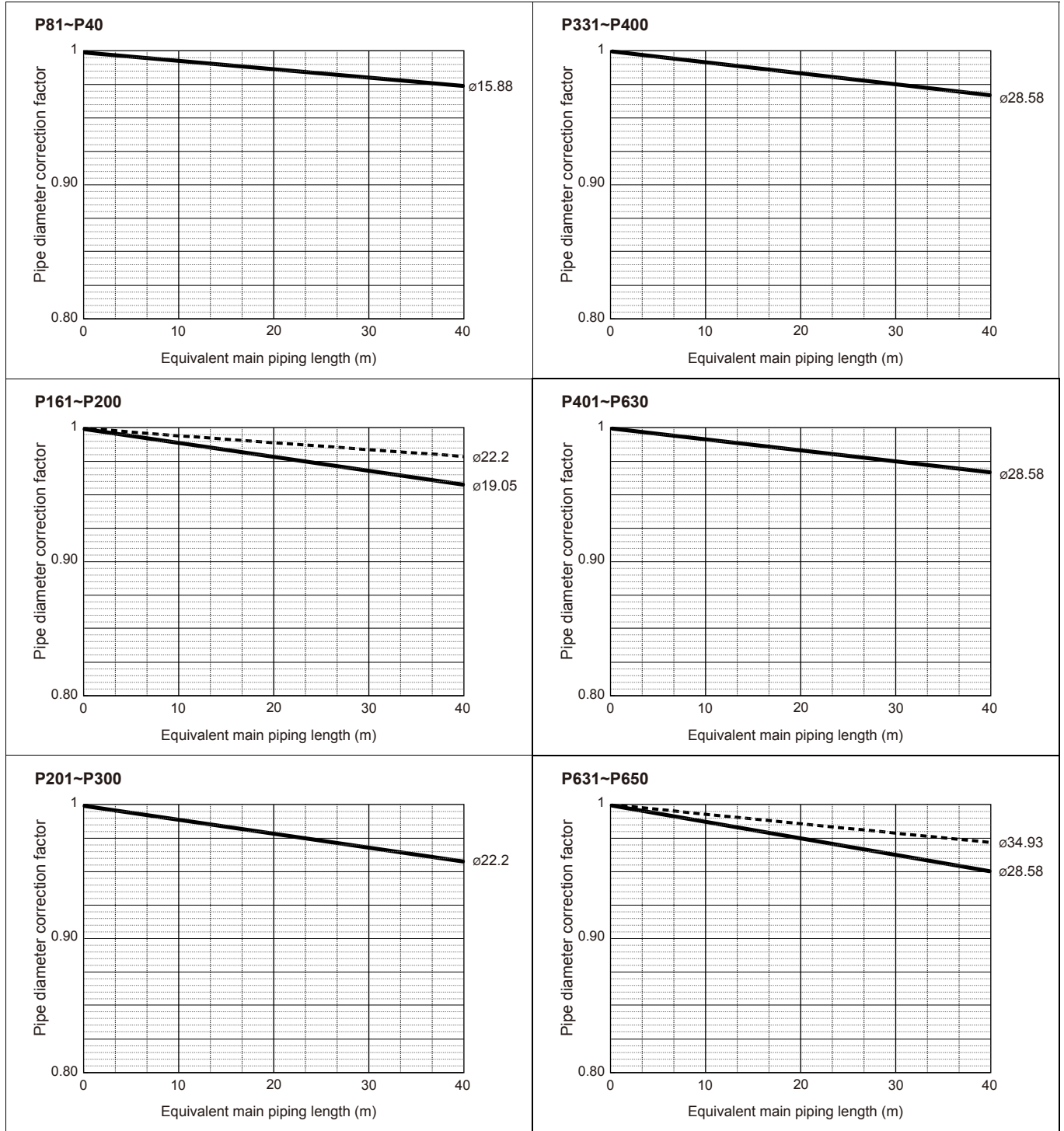

7. UNIT SELECTION

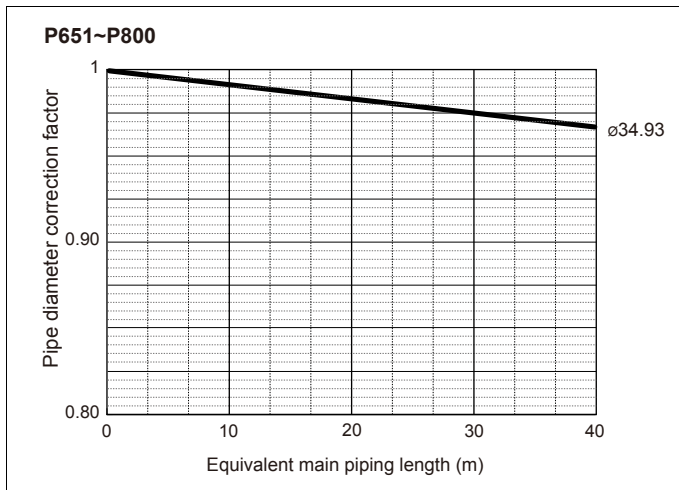

Capacity Table

1. Cooling [Ceiling concealed (Silent/Slim/High static pressure type)]	89
1-1. Cooling capacity with PUHY,PURY-RP200-250YJM	89
1-2. Cooling capacity with PUHY-RP300-400Y(S)JM,PURY-RP300YJM	93
1-3. Cooling capacity with PUHY-RP450-650YSJM	97
1-4. Cooling capacity with PUHY-RP700-800YSJM	101
1-5. Cooling capacity with PUHY-RP850-900YSJM	105
2. Cooling [Ceiling concealed (Middle static pressure type)]	109
2-1. Cooling capacity with PUHY,PURY-RP200-250YJM	109
2-2. Cooling capacity with PUHY-RP300-400Y(S)JM,PURY-RP300YJM	111
2-3. Cooling capacity with PUHY-RP450-650YSJM	113
2-4. Cooling capacity with PUHY-RP700-800YSJM	115
2-5. Cooling capacity with PUHY-RP850-900YSJM	117
3. Cooling [Ceiling cassette (1-way flow type)]	119
3-1. Cooling capacity with PUHY,PURY-RP200-250YJM	119
3-2. Cooling capacity with PUHY-RP300-400Y(S)JM,PURY-RP300YJM	120
3-3. Cooling capacity with PUHY-RP450-650YSJM	121
3-4. Cooling capacity with PUHY-RP700-800YSJM	122
3-5. Cooling capacity with PUHY-RP850-900YSJM	123
4. Cooling [Ceiling cassette (2-way flow type)]	124
4-1. Cooling capacity with PUHY,PURY-RP200-250YJM	124
4-2. Cooling capacity with PUHY-RP300-400Y(S)JM,PURY-RP300YJM	126
4-3. Cooling capacity with PUHY-RP450-650YSJM	128
4-4. Cooling capacity with PUHY-RP700-800YSJM	130
4-5. Cooling capacity with PUHY-RP850-900YSJM	132
5. Cooling [Ceiling cassette (4-way flow type)]	134
5-1. Cooling capacity with PUHY,PURY-RP200-250YJM	134
5-2. Cooling capacity with PUHY-RP300-400Y(S)JM,PURY-RP300YJM	136
5-3. Cooling capacity with PUHY-RP450-650YSJM	138
5-4. Cooling capacity with PUHY-RP700-800YSJM	140
5-5. Cooling capacity with PUHY-RP850-900YSJM	142
6. Cooling [Ceiling suspended]	144
6-1. Cooling capacity with PUHY,PURY-RP200-250YJM	144
6-2. Cooling capacity with PUHY-RP300-400Y(S)JM,PURY-RP300YJM	145
6-3. Cooling capacity with PUHY-RP450-650YSJM	146
6-4. Cooling capacity with PUHY-RP700-800YSJM	147
6-5. Cooling capacity with PUHY-RP850-900YSJM	148
7. Cooling [Wall mounted]	149
7-1. Cooling capacity with PUHY,PURY-RP200-250YJM	149
7-2. Cooling capacity with PUHY-RP300-400Y(S)JM,PURY-RP300YJM	151
7-3. Cooling capacity with PUHY-RP450-650YSJM	153
7-4. Cooling capacity with PUHY-RP700-800YSJM	155
7-5. Cooling capacity with PUHY-RP850-900YSJM	157
8. Cooling [Floor standing (Exposed 2-way/Exposed/Concealed type)]	159
8-1. Cooling capacity with PUHY,PURY-RP200-250YJM	159
8-2. Cooling capacity with PUHY-RP300-400Y(S)JM,PURY-RP300YJM	162
8-3. Cooling capacity with PUHY-RP450-650YSJM	165
8-4. Cooling capacity with PUHY-RP700-800YSJM	168
8-5. Cooling capacity with PUHY-RP850-900YSJM	171
9. Heating [All indoor units]	174
9-1. Heating capacity with PUHY,PURY-RP200-250YJM	174
9-2. Heating capacity with PUHY-RP300-400Y(S)JM,PURY-RP300YJM	175
9-3. Heating capacity with PUHY-RP450-650YSJM	176
9-4. Heating capacity with PUHY-RP700-800YSJM	177
9-5. Heating capacity with PUHY-RP850-900YSJM	178
9-6. Heating capacity with PUHY,PURY-RP200-250YJM "COP priority mode"	179

CAPACITY TABLES

9-7. Heating capacity with PUHY-RP300-400Y(S)JM,PURY-RP300YJM "COP priority mode"	180
9-8. Heating capacity with PUHY-RP450-650YSJM "COP priority mode"	181
9-9. Heating capacity with PUHY-RP700-800YSJM "COP priority mode"	182
9-10. Heating capacity with PUHY-RP850-900YSJM "COP priority mode"	183
10. Cooling [Ceiling concealed (Fresh air intake)]	184
10-1. Cooling capacity.....	184
10-2. Outlet air temp. cooled.....	185
11. Heating [Ceiling concealed (Fresh air intake)]	186
11-1. Heating capacity	186
11-2. Outlet air temp. heated	187

1. Cooling [Ceiling concealed (Silent/Slim/High static pressure type)]

PEFY-P-VMH-E

CA:Capacity(kW) , SHC:Sensible Heat Capacity(kW)

Model size (Rated kW)	Outdoor air temp. °C D.B.	Indoor air temp.													
		21.5°C D.B. 15°C W.B.		23°C D.B. 16°C W.B.		25°C D.B. 18°C W.B.		27°C D.B. 19°C W.B.		28°C D.B. 20°C W.B.		30°C D.B. 22°C W.B.		32°C D.B. 24°C W.B.	
		CA	SHC	CA	SHC	CA	SHC	CA	SHC	CA	SHC	CA	SHC	CA	SHC
140 (16.0)	20.0	15.2	11.2	15.8	11.6	16.8	11.5	17.3	12.2	17.8	12.1	18.9	11.9	20.2	11.8
	22.5	15.2	11.2	15.8	11.6	16.8	11.5	17.3	12.2	17.8	12.1	18.9	11.9	20.2	11.8
	25.0	15.2	11.2	15.8	11.6	16.8	11.5	17.3	12.1	17.7	12.0	18.7	11.9	19.9	11.7
	27.5	15.2	11.2	15.6	11.5	16.5	11.4	16.9	12.0	17.4	11.9	18.4	11.7	19.5	11.6
	30.0	14.9	11.1	15.3	11.4	16.2	11.2	16.6	11.9	17.1	11.8	18.0	11.6	19.1	11.4
	32.5	14.6	10.9	15.0	11.2	15.9	11.1	16.3	11.7	16.8	11.6	17.6	11.4	18.7	11.3
	35.0	14.3	10.8	14.8	11.1	15.6	11.0	16.0	11.6	16.4	11.5	17.3	11.3	18.3	11.1
	37.5	14.1	10.7	14.5	11.0	15.3	10.8	15.7	11.5	16.1	11.4	16.9	11.2	17.9	11.0
	40.0	13.8	10.5	14.2	10.8	15.0	10.7	15.4	11.3	15.8	11.3	16.6	11.0	17.6	10.9
43.0	13.4	10.4	13.8	10.7	14.6	10.5	15.0	11.2	15.4	11.1	16.1	10.9	17.1	10.7	
200 (22.4)	20.0	21.3	16.1	22.1	16.6	23.5	16.5	24.2	17.5	25.0	17.4	26.5	17.2	28.3	17.0
	22.5	21.3	16.1	22.1	16.6	23.5	16.5	24.2	17.5	25.0	17.4	26.5	17.2	28.3	17.0
	25.0	21.3	16.1	22.1	16.6	23.5	16.5	24.2	17.5	24.8	17.3	26.2	17.1	27.9	16.8
	27.5	21.2	16.0	21.8	16.5	23.1	16.3	23.7	17.3	24.3	17.1	25.7	16.9	27.3	16.6
	30.0	20.8	15.9	21.4	16.3	22.7	16.1	23.3	17.1	23.9	16.9	25.2	16.7	26.8	16.4
	32.5	20.4	15.7	21.0	16.1	22.3	16.0	22.9	16.9	23.5	16.8	24.7	16.5	26.2	16.2
	35.0	20.1	15.5	20.7	16.0	21.9	15.8	22.4	16.7	23.0	16.6	24.2	16.3	25.7	16.1
	37.5	19.7	15.3	20.3	15.8	21.4	15.6	22.0	16.5	22.6	16.4	23.7	16.1	25.1	15.9
	40.0	19.3	15.1	19.9	15.6	21.0	15.4	21.6	16.4	22.1	16.2	23.2	15.9	24.6	15.7
43.0	18.8	14.9	19.4	15.4	20.5	15.2	21.1	16.1	21.6	16.0	22.6	15.7	23.9	15.5	
250 (28.0)	20.0	26.6	20.0	27.6	20.7	29.4	20.5	30.3	21.7	31.2	21.6	33.1	21.3	35.4	21.1
	22.5	26.6	20.0	27.6	20.7	29.4	20.5	30.3	21.7	31.2	21.6	33.1	21.3	35.4	21.1
	25.0	26.6	20.0	27.6	20.7	29.4	20.5	30.2	21.7	31.0	21.5	32.8	21.2	34.8	20.9
	27.5	26.5	20.0	27.3	20.5	28.9	20.3	29.7	21.5	30.4	21.3	32.1	20.9	34.2	20.7
	30.0	26.0	19.7	26.8	20.3	28.4	20.1	29.1	21.2	29.9	21.1	31.5	20.7	33.5	20.4
	32.5	25.6	19.5	26.3	20.1	27.8	19.8	28.6	21.0	29.3	20.8	30.9	20.5	32.8	20.2
	35.0	25.1	19.3	25.8	19.8	27.3	19.6	28.0	20.7	28.8	20.6	30.3	20.2	32.1	19.9
	37.5	24.6	19.0	25.3	19.6	26.8	19.4	27.5	20.5	28.2	20.4	29.6	20.0	31.4	19.7
	40.0	24.1	18.8	24.8	19.4	26.3	19.1	27.0	20.3	27.7	20.2	29.0	19.8	30.7	19.5
43.0	23.5	18.5	24.2	19.1	25.6	18.9	26.3	20.0	27.0	19.9	28.2	19.5	29.9	19.2	

kcal/h=kW x 860 , BTU/h = kW x 3,412

1. Cooling [Ceiling concealed (Silent/Slim/High static pressure type)]

PEFY-P-VMR-E-L/R

CA:Capacity(kW) , SHC:Sensible Heat Capacity(kW)

Model size (Rated kW)	Outdoor air temp. °C D.B.	Indoor air temp.													
		21.5°C D.B. 15°C W.B.		23°C D.B. 16°C W.B.		25°C D.B. 18°C W.B.		27°C D.B. 19°C W.B.		28°C D.B. 20°C W.B.		30°C D.B. 22°C W.B.		32°C D.B. 24°C W.B.	
		CA	SHC	CA	SHC	CA	SHC	CA	SHC	CA	SHC	CA	SHC	CA	SHC
20 (2.2)	20.0	2.1	1.7	2.2	1.8	2.3	1.8	2.4	1.9	2.5	1.9	2.6	1.8	2.8	1.8
	22.5	2.1	1.7	2.2	1.8	2.3	1.8	2.4	1.9	2.5	1.9	2.6	1.8	2.8	1.8
	25.0	2.1	1.7	2.2	1.8	2.3	1.8	2.4	1.9	2.4	1.9	2.6	1.8	2.7	1.8
	27.5	2.1	1.7	2.1	1.8	2.3	1.7	2.3	1.9	2.4	1.8	2.5	1.8	2.7	1.8
	30.0	2.0	1.7	2.1	1.7	2.2	1.7	2.3	1.8	2.3	1.8	2.5	1.8	2.6	1.8
	32.5	2.0	1.7	2.1	1.7	2.2	1.7	2.2	1.8	2.3	1.8	2.4	1.8	2.6	1.8
	35.0	2.0	1.7	2.0	1.7	2.1	1.7	2.2	1.8	2.3	1.8	2.4	1.8	2.5	1.7
	37.5	1.9	1.6	2.0	1.7	2.1	1.7	2.2	1.8	2.2	1.8	2.3	1.8	2.5	1.7
	40.0	1.9	1.6	2.0	1.7	2.1	1.7	2.1	1.8	2.2	1.8	2.3	1.7	2.4	1.7
43.0	1.8	1.6	1.9	1.7	2.0	1.6	2.1	1.8	2.1	1.7	2.2	1.7	2.3	1.7	
25 (2.8)	20.0	2.7	2.0	2.8	2.1	2.9	2.0	3.0	2.2	3.1	2.1	3.3	2.1	3.5	2.1
	22.5	2.7	2.0	2.8	2.1	2.9	2.0	3.0	2.2	3.1	2.1	3.3	2.1	3.5	2.1
	25.0	2.7	2.0	2.8	2.1	2.9	2.0	3.0	2.2	3.1	2.1	3.3	2.1	3.5	2.1
	27.5	2.7	2.0	2.7	2.0	2.9	2.0	3.0	2.1	3.0	2.1	3.2	2.1	3.4	2.1
	30.0	2.6	2.0	2.7	2.0	2.8	2.0	2.9	2.1	3.0	2.1	3.2	2.1	3.3	2.0
	32.5	2.6	1.9	2.6	2.0	2.8	2.0	2.9	2.1	2.9	2.1	3.1	2.0	3.3	2.0
	35.0	2.5	1.9	2.6	2.0	2.7	1.9	2.8	2.1	2.9	2.0	3.0	2.0	3.2	2.0
	37.5	2.5	1.9	2.5	1.9	2.7	1.9	2.8	2.0	2.8	2.0	3.0	2.0	3.1	2.0
	40.0	2.4	1.9	2.5	1.9	2.6	1.9	2.7	2.0	2.8	2.0	2.9	2.0	3.1	1.9
43.0	2.4	1.8	2.4	1.9	2.6	1.9	2.6	2.0	2.7	2.0	2.8	1.9	3.0	1.9	
32 (3.6)	20.0	3.4	2.4	3.5	2.5	3.8	2.5	3.9	2.6	4.0	2.6	4.3	2.6	4.6	2.6
	22.5	3.4	2.4	3.5	2.5	3.8	2.5	3.9	2.6	4.0	2.6	4.3	2.6	4.6	2.6
	25.0	3.4	2.4	3.5	2.5	3.8	2.5	3.9	2.6	4.0	2.6	4.2	2.6	4.5	2.5
	27.5	3.4	2.4	3.5	2.5	3.7	2.5	3.8	2.6	3.9	2.6	4.1	2.5	4.4	2.5
	30.0	3.3	2.4	3.4	2.5	3.6	2.4	3.7	2.6	3.8	2.5	4.1	2.5	4.3	2.5
	32.5	3.3	2.4	3.4	2.4	3.6	2.4	3.7	2.5	3.8	2.5	4.0	2.5	4.2	2.4
	35.0	3.2	2.3	3.3	2.4	3.5	2.4	3.6	2.5	3.7	2.5	3.9	2.4	4.1	2.4
	37.5	3.2	2.3	3.3	2.4	3.4	2.3	3.5	2.5	3.6	2.4	3.8	2.4	4.0	2.4
	40.0	3.1	2.3	3.2	2.3	3.4	2.3	3.5	2.4	3.6	2.4	3.7	2.4	3.9	2.3
43.0	3.0	2.2	3.1	2.3	3.3	2.3	3.4	2.4	3.5	2.4	3.6	2.3	3.8	2.3	

kcal/h=kW x 860 , BTU/h = kW x 3,412

1. Cooling [Ceiling concealed (Silent/Slim/High static pressure type)]

PEFY-P-VMH-E

CA:Capacity(kW) , SHC:Sensible Heat Capacity(kW)

Model size (Rated kW)	Outdoor air temp. °C D.B.	Indoor air temp.													
		21.5°C D.B. 15°C W.B.		23°C D.B. 16°C W.B.		25°C D.B. 18°C W.B.		27°C D.B. 19°C W.B.		28°C D.B. 20°C W.B.		30°C D.B. 22°C W.B.		32°C D.B. 24°C W.B.	
		CA	SHC	CA	SHC	CA	SHC	CA	SHC	CA	SHC	CA	SHC	CA	SHC
140 (16.0)	20.0	15.5	11.4	16.1	11.7	17.3	11.7	17.9	12.4	18.5	12.4	19.6	12.2	20.8	12.0
	22.5	15.5	11.4	16.0	11.7	17.0	11.6	17.6	12.3	18.1	12.2	19.2	12.1	20.4	11.9
	25.0	15.3	11.3	15.7	11.6	16.7	11.5	17.3	12.1	17.8	12.1	18.9	11.9	20.0	11.7
	27.5	15.0	11.1	15.4	11.4	16.4	11.3	16.9	12.0	17.4	11.9	18.5	11.8	19.6	11.6
	30.0	14.8	11.0	15.1	11.3	16.1	11.2	16.6	11.8	17.1	11.8	18.1	11.6	19.2	11.5
	32.5	14.5	10.9	14.8	11.1	15.7	11.0	16.3	11.7	16.8	11.6	17.8	11.5	18.8	11.3
	35.0	14.3	10.8	14.5	11.0	15.4	10.9	16.0	11.6	16.4	11.5	17.4	11.4	18.5	11.2
	37.5	14.0	10.6	14.2	10.8	15.1	10.7	15.6	11.4	16.1	11.4	17.0	11.2	18.1	11.0
	40.0	13.8	10.5	13.9	10.7	14.8	10.6	15.2	11.3	15.7	11.2	16.7	11.1	17.7	10.9
43.0	13.5	10.4	13.5	10.5	14.4	10.4	14.8	11.1	15.3	11.0	16.3	10.9	17.2	10.7	
200 (22.4)	20.0	21.8	16.3	22.5	16.8	24.2	16.8	25.0	17.8	25.9	17.8	27.5	17.5	29.1	17.3
	22.5	21.7	16.3	22.4	16.8	23.8	16.6	24.6	17.7	25.4	17.6	26.9	17.3	28.6	17.1
	25.0	21.4	16.1	21.9	16.6	23.4	16.4	24.2	17.5	24.9	17.4	26.4	17.1	28.0	16.9
	27.5	21.0	15.9	21.5	16.4	22.9	16.2	23.7	17.3	24.4	17.2	25.9	16.9	27.5	16.7
	30.0	20.7	15.8	21.1	16.2	22.5	16.0	23.2	17.1	23.9	17.0	25.4	16.7	26.9	16.5
	32.5	20.3	15.6	20.7	16.0	22.0	15.8	22.8	16.9	23.5	16.8	24.9	16.6	26.4	16.3
	35.0	20.0	15.4	20.3	15.8	21.6	15.7	22.4	16.7	23.0	16.6	24.4	16.4	25.8	16.1
	37.5	19.6	15.3	19.9	15.6	21.1	15.5	21.8	16.5	22.5	16.4	23.9	16.2	25.3	15.9
	40.0	19.3	15.1	19.4	15.4	20.7	15.3	21.3	16.3	22.0	16.2	23.4	16.0	24.8	15.7
43.0	18.9	14.9	18.9	15.2	20.1	15.0	20.8	16.0	21.4	16.0	22.8	15.8	24.1	15.5	
250 (28.0)	20.0	27.2	20.3	28.1	20.9	30.3	20.9	31.3	22.2	32.3	22.1	34.3	21.8	36.4	21.5
	22.5	27.1	20.3	28.0	20.8	29.8	20.7	30.8	21.9	31.7	21.8	33.7	21.5	35.7	21.2
	25.0	26.7	20.0	27.4	20.6	29.2	20.4	30.2	21.7	31.1	21.6	33.0	21.3	35.0	21.0
	27.5	26.3	19.8	26.9	20.3	28.7	20.2	29.6	21.4	30.5	21.3	32.4	21.1	34.3	20.7
	30.0	25.8	19.6	26.4	20.1	28.1	19.9	29.0	21.2	29.9	21.1	31.8	20.8	33.7	20.5
	32.5	25.4	19.4	25.9	19.9	27.5	19.7	28.4	20.9	29.3	20.8	31.1	20.6	33.0	20.2
	35.0	25.0	19.2	25.3	19.6	27.0	19.4	28.0	20.7	28.7	20.6	30.5	20.3	32.3	20.0
	37.5	24.5	19.0	24.8	19.4	26.4	19.2	27.3	20.4	28.1	20.3	29.8	20.1	31.6	19.8
	40.0	24.1	18.8	24.3	19.1	25.9	19.0	26.7	20.2	27.5	20.1	29.2	19.8	30.9	19.5
43.0	23.6	18.5	23.7	18.8	25.2	18.7	26.0	19.9	26.8	19.8	28.4	19.6	30.1	19.3	

kcal/h=kW x 860 , BTU/h = kW x 3,412

1. Cooling [Ceiling concealed (Silent/Slim/High static pressure type)]

PEFY-P-VMR-E-L/R

CA:Capacity(kW) , SHC:Sensible Heat Capacity(kW)

Model size (Rated kW)	Outdoor air temp. °C D.B.	Indoor air temp.													
		21.5°C D.B. 15°C W.B.		23°C D.B. 16°C W.B.		25°C D.B. 18°C W.B.		27°C D.B. 19°C W.B.		28°C D.B. 20°C W.B.		30°C D.B. 22°C W.B.		32°C D.B. 24°C W.B.	
		CA	SHC	CA	SHC	CA	SHC	CA	SHC	CA	SHC	CA	SHC	CA	SHC
20 (2.2)	20.0	2.1	1.7	2.2	1.8	2.4	1.8	2.5	1.9	2.5	1.9	2.7	1.9	2.9	1.9
	22.5	2.1	1.7	2.2	1.8	2.3	1.8	2.4	1.9	2.5	1.9	2.6	1.9	2.8	1.8
	25.0	2.1	1.7	2.2	1.8	2.3	1.8	2.4	1.9	2.4	1.9	2.6	1.8	2.8	1.8
	27.5	2.1	1.7	2.1	1.8	2.3	1.7	2.3	1.9	2.4	1.9	2.5	1.8	2.7	1.8
	30.0	2.0	1.7	2.1	1.7	2.2	1.7	2.3	1.8	2.4	1.8	2.5	1.8	2.6	1.8
	32.5	2.0	1.7	2.0	1.7	2.2	1.7	2.2	1.8	2.3	1.8	2.4	1.8	2.6	1.8
	35.0	2.0	1.7	2.0	1.7	2.1	1.7	2.2	1.8	2.3	1.8	2.4	1.8	2.5	1.7
	37.5	1.9	1.6	2.0	1.7	2.1	1.7	2.1	1.8	2.2	1.8	2.3	1.8	2.5	1.7
	40.0	1.9	1.6	1.9	1.7	2.0	1.6	2.1	1.8	2.2	1.8	2.3	1.7	2.4	1.7
43.0	1.9	1.6	1.9	1.6	2.0	1.6	2.0	1.7	2.1	1.7	2.2	1.7	2.4	1.7	
25 (2.8)	20.0	2.7	2.0	2.8	2.1	3.0	2.1	3.1	2.2	3.2	2.2	3.4	2.2	3.6	2.1
	22.5	2.7	2.0	2.8	2.1	3.0	2.1	3.1	2.2	3.2	2.2	3.4	2.1	3.6	2.1
	25.0	2.7	2.0	2.7	2.0	2.9	2.0	3.0	2.2	3.1	2.1	3.3	2.1	3.5	2.1
	27.5	2.6	2.0	2.7	2.0	2.9	2.0	3.0	2.1	3.1	2.1	3.2	2.1	3.4	2.1
	30.0	2.6	1.9	2.6	2.0	2.8	2.0	2.9	2.1	3.0	2.1	3.2	2.1	3.4	2.0
	32.5	2.5	1.9	2.6	2.0	2.8	2.0	2.8	2.1	2.9	2.1	3.1	2.0	3.3	2.0
	35.0	2.5	1.9	2.5	1.9	2.7	1.9	2.8	2.1	2.9	2.0	3.0	2.0	3.2	2.0
	37.5	2.5	1.9	2.5	1.9	2.6	1.9	2.7	2.0	2.8	2.0	3.0	2.0	3.2	2.0
	40.0	2.4	1.9	2.4	1.9	2.6	1.9	2.7	2.0	2.8	2.0	2.9	2.0	3.1	1.9
43.0	2.4	1.8	2.4	1.9	2.5	1.9	2.6	2.0	2.7	2.0	2.8	1.9	3.0	1.9	
32 (3.6)	20.0	3.5	2.5	3.6	2.5	3.9	2.5	4.0	2.7	4.2	2.7	4.4	2.6	4.7	2.6
	22.5	3.5	2.5	3.6	2.5	3.8	2.5	4.0	2.7	4.1	2.6	4.3	2.6	4.6	2.6
	25.0	3.4	2.4	3.5	2.5	3.8	2.5	3.9	2.6	4.0	2.6	4.2	2.6	4.5	2.5
	27.5	3.4	2.4	3.5	2.5	3.7	2.5	3.8	2.6	3.9	2.6	4.2	2.5	4.4	2.5
	30.0	3.3	2.4	3.4	2.4	3.6	2.4	3.7	2.6	3.8	2.5	4.1	2.5	4.3	2.5
	32.5	3.3	2.4	3.3	2.4	3.5	2.4	3.7	2.5	3.8	2.5	4.0	2.5	4.2	2.4
	35.0	3.2	2.3	3.3	2.4	3.5	2.3	3.6	2.5	3.7	2.5	3.9	2.4	4.2	2.4
	37.5	3.2	2.3	3.2	2.3	3.4	2.3	3.5	2.4	3.6	2.4	3.8	2.4	4.1	2.4
	40.0	3.1	2.3	3.1	2.3	3.3	2.3	3.4	2.4	3.5	2.4	3.8	2.4	4.0	2.3
43.0	3.0	2.2	3.0	2.3	3.2	2.2	3.3	2.4	3.4	2.4	3.7	2.3	3.9	2.3	

kcal/h=kW x 860 , BTU/h = kW x 3,412

1. Cooling [Ceiling concealed (Silent/Slim/High static pressure type)]

1-3. Cooling capacity with PUHY-RP450-650YSJM

PEFY-P-VMH-E

CA:Capacity(kW) , SHC:Sensible Heat Capacity(kW)

Model size (Rated kW)	Outdoor air temp. °C D.B.	Indoor air temp.													
		21.5°C D.B. 15°C W.B.		23°C D.B. 16°C W.B.		25°C D.B. 18°C W.B.		27°C D.B. 19°C W.B.		28°C D.B. 20°C W.B.		30°C D.B. 22°C W.B.		32°C D.B. 24°C W.B.	
		CA	SHC	CA	SHC	CA	SHC	CA	SHC	CA	SHC	CA	SHC	CA	SHC
40 (4.5)	20.0	4.3	3.2	4.4	3.3	4.7	3.3	4.8	3.5	5.0	3.5	5.3	3.5	5.7	3.4
	22.5	4.2	3.2	4.3	3.3	4.6	3.3	4.8	3.5	4.9	3.5	5.3	3.5	5.6	3.4
	25.0	4.2	3.2	4.3	3.3	4.6	3.3	4.7	3.5	4.9	3.5	5.2	3.4	5.6	3.4
	27.5	4.1	3.2	4.2	3.3	4.5	3.3	4.7	3.5	4.8	3.5	5.2	3.4	5.5	3.4
	30.0	4.1	3.2	4.2	3.2	4.5	3.2	4.6	3.4	4.8	3.4	5.1	3.4	5.5	3.4
	32.5	4.0	3.1	4.1	3.2	4.4	3.2	4.6	3.4	4.7	3.4	5.1	3.4	5.4	3.3
	35.0	4.0	3.1	4.1	3.2	4.4	3.2	4.5	3.4	4.7	3.4	5.0	3.4	5.4	3.3
	37.5	4.0	3.1	4.0	3.2	4.3	3.2	4.5	3.4	4.6	3.4	5.0	3.3	5.3	3.3
	40.0	3.9	3.1	4.0	3.1	4.3	3.1	4.4	3.4	4.6	3.3	4.9	3.3	5.3	3.3
43.0	3.9	3.1	3.9	3.1	4.2	3.1	4.4	3.3	4.5	3.3	4.9	3.3	5.2	3.3	
50 (5.6)	20.0	5.3	3.8	5.5	3.9	5.8	3.9	6.0	4.1	6.2	4.1	6.6	4.0	7.0	4.0
	22.5	5.2	3.8	5.4	3.9	5.8	3.9	6.0	4.1	6.2	4.1	6.6	4.0	7.0	4.0
	25.0	5.2	3.7	5.3	3.8	5.7	3.8	5.9	4.0	6.1	4.0	6.5	4.0	6.9	3.9
	27.5	5.1	3.7	5.3	3.8	5.6	3.8	5.8	4.0	6.0	4.0	6.4	4.0	6.9	3.9
	30.0	5.1	3.7	5.2	3.8	5.6	3.8	5.8	4.0	6.0	4.0	6.4	3.9	6.8	3.9
	32.5	5.0	3.7	5.1	3.7	5.5	3.7	5.7	4.0	5.9	3.9	6.3	3.9	6.7	3.9
	35.0	5.0	3.6	5.1	3.7	5.4	3.7	5.6	3.9	5.8	3.9	6.2	3.9	6.7	3.8
	37.5	4.9	3.6	5.0	3.7	5.4	3.7	5.6	3.9	5.8	3.9	6.2	3.9	6.6	3.8
	40.0	4.9	3.6	4.9	3.6	5.3	3.6	5.5	3.9	5.7	3.9	6.1	3.8	6.5	3.8
43.0	4.8	3.6	4.9	3.6	5.2	3.6	5.4	3.8	5.6	3.8	6.0	3.8	6.5	3.8	
63 (7.1)	20.0	6.7	5.0	6.9	5.1	7.4	5.1	7.6	5.4	7.9	5.4	8.4	5.3	8.9	5.3
	22.5	6.6	5.0	6.8	5.1	7.3	5.1	7.6	5.4	7.8	5.4	8.3	5.3	8.8	5.2
	25.0	6.6	4.9	6.8	5.1	7.2	5.0	7.5	5.3	7.7	5.3	8.2	5.3	8.8	5.2
	27.5	6.5	4.9	6.7	5.0	7.2	5.0	7.4	5.3	7.6	5.3	8.2	5.2	8.7	5.2
	30.0	6.4	4.9	6.6	5.0	7.1	5.0	7.3	5.3	7.6	5.3	8.1	5.2	8.6	5.1
	32.5	6.4	4.8	6.5	4.9	7.0	4.9	7.2	5.2	7.5	5.2	8.0	5.2	8.5	5.1
	35.0	6.3	4.8	6.4	4.9	6.9	4.9	7.1	5.2	7.4	5.2	7.9	5.1	8.5	5.1
	37.5	6.2	4.8	6.3	4.9	6.8	4.9	7.1	5.2	7.3	5.2	7.8	5.1	8.4	5.1
	40.0	6.2	4.7	6.3	4.8	6.7	4.8	7.0	5.1	7.2	5.1	7.8	5.1	8.3	5.0
43.0	6.1	4.7	6.2	4.8	6.7	4.8	6.9	5.1	7.1	5.1	7.7	5.0	8.2	5.0	
71 (8.0)	20.0	7.6	5.6	7.8	5.7	8.3	5.7	8.6	6.0	8.9	6.0	9.4	5.9	10.0	5.9
	22.5	7.5	5.5	7.7	5.7	8.2	5.7	8.5	6.0	8.8	6.0	9.4	5.9	10.0	5.8
	25.0	7.4	5.5	7.6	5.6	8.1	5.6	8.4	6.0	8.7	5.9	9.3	5.9	9.9	5.8
	27.5	7.3	5.5	7.5	5.6	8.1	5.6	8.3	5.9	8.6	5.9	9.2	5.8	9.8	5.8
	30.0	7.3	5.4	7.4	5.6	8.0	5.5	8.2	5.9	8.5	5.9	9.1	5.8	9.7	5.7
	32.5	7.2	5.4	7.3	5.5	7.9	5.5	8.2	5.8	8.4	5.8	9.0	5.8	9.6	5.7
	35.0	7.1	5.4	7.2	5.5	7.8	5.5	8.0	5.8	8.3	5.8	8.9	5.7	9.5	5.7
	37.5	7.0	5.3	7.2	5.4	7.7	5.4	8.0	5.8	8.3	5.7	8.8	5.7	9.4	5.6
	40.0	7.0	5.3	7.1	5.4	7.6	5.4	7.9	5.7	8.2	5.7	8.7	5.7	9.4	5.6
43.0	6.9	5.2	7.0	5.3	7.5	5.3	7.8	5.7	8.1	5.7	8.6	5.6	9.2	5.6	
80 (9.0)	20.0	8.5	6.3	8.8	6.5	9.4	6.5	9.7	6.8	10.0	6.8	10.6	6.7	11.3	6.6
	22.5	8.4	6.3	8.7	6.4	9.3	6.4	9.6	6.8	9.9	6.8	10.5	6.7	11.2	6.6
	25.0	8.3	6.2	8.6	6.4	9.2	6.4	9.5	6.8	9.8	6.7	10.4	6.7	11.1	6.6
	27.5	8.3	6.2	8.5	6.3	9.1	6.3	9.4	6.7	9.7	6.7	10.3	6.6	11.0	6.5
	30.0	8.2	6.1	8.4	6.3	9.0	6.3	9.3	6.7	9.6	6.6	10.2	6.6	10.9	6.5
	32.5	8.1	6.1	8.3	6.2	8.9	6.2	9.2	6.6	9.5	6.6	10.1	6.5	10.8	6.5
	35.0	8.0	6.1	8.1	6.2	8.8	6.2	9.0	6.5	9.4	6.6	10.0	6.5	10.7	6.4
	37.5	7.9	6.0	8.0	6.1	8.7	6.1	9.0	6.5	9.3	6.5	9.9	6.5	10.6	6.4
	40.0	7.8	6.0	7.9	6.1	8.6	6.1	8.9	6.5	9.2	6.5	9.8	6.4	10.5	6.4
43.0	7.7	5.9	7.8	6.0	8.4	6.0	8.7	6.4	9.1	6.4	9.7	6.4	10.4	6.3	
100 (11.2)	20.0	10.6	8.5	10.9	8.8	11.7	8.7	12.0	9.3	12.4	9.3	13.2	9.2	14.1	9.0
	22.5	10.5	8.4	10.8	8.7	11.5	8.7	11.9	9.3	12.3	9.2	13.1	9.1	13.9	9.0
	25.0	10.4	8.4	10.6	8.7	11.4	8.6	11.8	9.2	12.2	9.2	13.0	9.1	13.8	9.0
	27.5	10.3	8.3	10.5	8.6	11.3	8.6	11.7	9.2	12.1	9.1	12.9	9.0	13.7	8.9
	30.0	10.2	8.3	10.4	8.5	11.2	8.5	11.5	9.1	11.9	9.1	12.7	9.0	13.6	8.9
	32.5	10.1	8.2	10.3	8.5	11.0	8.5	11.4	9.0	11.8	9.0	12.6	8.9	13.5	8.8
	35.0	9.9	8.2	10.1	8.4	10.9	8.4	11.2	9.0	11.7	9.0	12.5	8.9	13.3	8.8
	37.5	9.8	8.1	10.0	8.4	10.8	8.3	11.2	8.9	11.6	8.9	12.4	8.8	13.2	8.8
	40.0	9.7	8.1	9.9	8.3	10.6	8.3	11.0	8.9	11.4	8.9	12.2	8.8	13.1	8.7
43.0	9.6	8.0	9.7	8.2	10.5	8.2	10.9	8.8	11.3	8.8	12.1	8.7	12.9	8.7	
125 (14.0)	20.0	13.2	9.8	13.6	10.1	14.6	10.0	15.1	10.6	15.5	10.6	16.5	10.4	17.6	10.3
	22.5	13.1	9.7	13.5	10.0	14.4	9.9	14.9	10.5	15.4	10.5	16.4	10.4	17.4	10.2
	25.0	13.0	9.7	13.3	9.9	14.3	9.9	14.7	10.5	15.2	10.4	16.2	10.3	17.3	10.2
	27.5	12.8	9.6	13.2	9.8	14.1	9.8	14.6	10.4	15.1	10.4	16.1	10.3	17.1	10.1
	30.0	12.7	9.5	13.0	9.8	13.9	9.7	14.4	10.3	14.9	10.3	15.9	10.2	17.0	10.1
	32.5	12.6	9.5	12.8	9.7	13.8	9.7	14.3	10.3	14.8	10.2	15.8	10.1	16.8	10.0
	35.0	12.4	9.4	12.7	9.6	13.6	9.6	14.0	10.1	14.6	10.2	15.6	10.1	16.7	10.0
	37.5	12.3	9.3	12.5	9.5	13.5	9.5	14.0	10.1	14.4	10.1	15.5	10.0	16.5	9.9
	40.0	12.2	9.3	12.4	9.5	13.3	9.4	13.8	10.1	14.3	10.0	15.3	10.0	16.4	9.9
43.0	12.0	9.2	12.2	9.4	13.1	9.4	13.6	10.0	14.1	9.9	15.1	9.9	16.2	9.8	

kcal/h=kW x 860 , BTU/h = kW x 3,412

1. Cooling [Ceiling concealed (Silent/Slim/High static pressure type)]

PEFY-P-VMH-E

CA:Capacity(kW) , SHC:Sensible Heat Capacity(kW)

Model size (Rated kW)	Outdoor air temp. °C D.B.	Indoor air temp.													
		21.5°C D.B. 15°C W.B.		23°C D.B. 16°C W.B.		25°C D.B. 18°C W.B.		27°C D.B. 19°C W.B.		28°C D.B. 20°C W.B.		30°C D.B. 22°C W.B.		32°C D.B. 24°C W.B.	
		CA	SHC	CA	SHC	CA	SHC	CA	SHC	CA	SHC	CA	SHC	CA	SHC
140 (16.0)	20.0	15.1	11.2	15.6	11.5	16.7	11.4	17.2	12.1	17.8	12.1	18.9	11.9	20.1	11.8
	22.5	15.0	11.1	15.4	11.4	16.5	11.4	17.0	12.0	17.6	12.0	18.7	11.9	19.9	11.7
	25.0	14.8	11.0	15.2	11.3	16.3	11.3	16.8	12.0	17.4	11.9	18.5	11.8	19.7	11.6
	27.5	14.7	11.0	15.0	11.2	16.1	11.2	16.7	11.9	17.2	11.8	18.4	11.7	19.6	11.6
	30.0	14.5	10.9	14.9	11.2	15.9	11.1	16.5	11.8	17.0	11.8	18.2	11.7	19.4	11.5
	32.5	14.4	10.8	14.7	11.1	15.8	11.0	16.3	11.7	16.9	11.7	18.0	11.6	19.2	11.5
	35.0	14.2	10.7	14.5	11.0	15.6	11.0	16.0	11.6	16.7	11.6	17.8	11.5	19.1	11.4
	37.5	14.1	10.7	14.3	10.9	15.4	10.9	15.9	11.6	16.5	11.5	17.7	11.4	18.9	11.3
	40.0	13.9	10.6	14.1	10.8	15.2	10.8	15.8	11.5	16.3	11.5	17.5	11.4	18.7	11.3
43.0	13.7	10.5	13.9	10.7	15.0	10.7	15.6	11.4	16.1	11.4	17.3	11.3	18.5	11.2	
200 (22.4)	20.0	21.2	16.0	21.8	16.5	23.3	16.4	24.1	17.4	24.9	17.3	26.5	17.1	28.1	16.9
	22.5	21.0	15.9	21.6	16.4	23.1	16.3	23.8	17.3	24.6	17.2	26.2	17.1	27.9	16.8
	25.0	20.7	15.8	21.3	16.3	22.8	16.2	23.6	17.2	24.4	17.1	26.0	17.0	27.6	16.7
	27.5	20.5	15.7	21.0	16.1	22.6	16.1	23.3	17.1	24.1	17.0	25.7	16.9	27.4	16.7
	30.0	20.3	15.6	20.8	16.0	22.3	16.0	23.1	17.0	23.9	16.9	25.5	16.8	27.2	16.6
	32.5	20.1	15.5	20.5	15.9	22.1	15.9	22.8	16.9	23.6	16.8	25.2	16.7	26.9	16.5
	35.0	19.9	15.4	20.3	15.8	21.8	15.7	22.4	16.7	23.4	16.7	25.0	16.6	26.7	16.4
	37.5	19.7	15.3	20.0	15.7	21.5	15.6	22.3	16.7	23.1	16.6	24.7	16.5	26.4	16.3
	40.0	19.5	15.2	19.8	15.5	21.3	15.5	22.1	16.6	22.8	16.5	24.5	16.4	26.2	16.2
43.0	19.2	15.1	19.5	15.4	21.0	15.4	21.8	16.4	22.6	16.4	24.2	16.3	25.9	16.1	
250 (28.0)	20.0	26.5	19.9	27.3	20.5	29.2	20.4	30.1	21.7	31.1	21.6	33.1	21.3	35.2	21.0
	22.5	26.2	19.8	26.9	20.4	28.8	20.3	29.8	21.5	30.8	21.4	32.8	21.2	34.9	20.9
	25.0	25.9	19.7	26.6	20.2	28.5	20.1	29.5	21.4	30.5	21.3	32.4	21.1	34.6	20.8
	27.5	25.7	19.5	26.3	20.1	28.2	20.0	29.2	21.2	30.1	21.2	32.1	21.0	34.3	20.7
	30.0	25.4	19.4	26.0	19.9	27.9	19.8	28.9	21.1	29.8	21.0	31.8	20.8	33.9	20.6
	32.5	25.1	19.3	25.7	19.8	27.6	19.7	28.5	21.0	29.5	20.9	31.5	20.7	33.6	20.5
	35.0	24.9	19.2	25.4	19.6	27.2	19.6	28.0	20.7	29.2	20.8	31.2	20.6	33.3	20.4
	37.5	24.6	19.0	25.0	19.5	26.9	19.4	27.9	20.7	28.9	20.6	30.9	20.5	33.0	20.3
	40.0	24.3	18.9	24.7	19.3	26.6	19.3	27.6	20.6	28.6	20.5	30.6	20.4	32.7	20.2
43.0	24.0	18.7	24.3	19.1	26.2	19.1	27.2	20.4	28.2	20.4	30.2	20.2	32.4	20.0	

kcal/h=kW x 860 , BTU/h = kW x 3,412

1. Cooling [Ceiling concealed (Silent/Slim/High static pressure type)]

PEFY-P-VMR-E-L/R

CA:Capacity(kW) , SHC:Sensible Heat Capacity(kW)

Model size (Rated kW)	Outdoor air temp. °C D.B.	Indoor air temp.													
		21.5°C D.B. 15°C W.B.		23°C D.B. 16°C W.B.		25°C D.B. 18°C W.B.		27°C D.B. 19°C W.B.		28°C D.B. 20°C W.B.		30°C D.B. 22°C W.B.		32°C D.B. 24°C W.B.	
		CA	SHC	CA	SHC	CA	SHC	CA	SHC	CA	SHC	CA	SHC	CA	SHC
20 (2.2)	20.0	2.1	1.7	2.1	1.8	2.3	1.8	2.4	1.9	2.4	1.9	2.6	1.8	2.8	1.8
	22.5	2.1	1.7	2.1	1.8	2.3	1.7	2.3	1.9	2.4	1.9	2.6	1.8	2.7	1.8
	25.0	2.0	1.7	2.1	1.7	2.2	1.7	2.3	1.9	2.4	1.8	2.5	1.8	2.7	1.8
	27.5	2.0	1.7	2.1	1.7	2.2	1.7	2.3	1.8	2.4	1.8	2.5	1.8	2.7	1.8
	30.0	2.0	1.7	2.0	1.7	2.2	1.7	2.3	1.8	2.3	1.8	2.5	1.8	2.7	1.8
	32.5	2.0	1.7	2.0	1.7	2.2	1.7	2.2	1.8	2.3	1.8	2.5	1.8	2.6	1.8
	35.0	2.0	1.7	2.0	1.7	2.1	1.7	2.2	1.8	2.3	1.8	2.5	1.8	2.6	1.8
	37.5	1.9	1.6	2.0	1.7	2.1	1.7	2.2	1.8	2.3	1.8	2.4	1.8	2.6	1.8
	40.0	1.9	1.6	1.9	1.7	2.1	1.7	2.2	1.8	2.2	1.8	2.4	1.8	2.6	1.8
43.0	1.9	1.6	1.9	1.7	2.1	1.7	2.1	1.8	2.2	1.8	2.4	1.8	2.5	1.8	
25 (2.8)	20.0	2.6	2.0	2.7	2.0	2.9	2.0	3.0	2.1	3.1	2.1	3.3	2.1	3.5	2.1
	22.5	2.6	2.0	2.7	2.0	2.9	2.0	3.0	2.1	3.1	2.1	3.3	2.1	3.5	2.1
	25.0	2.6	2.0	2.7	2.0	2.9	2.0	2.9	2.1	3.0	2.1	3.2	2.1	3.5	2.1
	27.5	2.6	1.9	2.6	2.0	2.8	2.0	2.9	2.1	3.0	2.1	3.2	2.1	3.4	2.1
	30.0	2.5	1.9	2.6	2.0	2.8	2.0	2.9	2.1	3.0	2.1	3.2	2.1	3.4	2.0
	32.5	2.5	1.9	2.6	2.0	2.8	2.0	2.9	2.1	3.0	2.1	3.2	2.1	3.4	2.0
	35.0	2.5	1.9	2.5	1.9	2.7	1.9	2.8	2.1	2.9	2.1	3.1	2.0	3.3	2.0
	37.5	2.5	1.9	2.5	1.9	2.7	1.9	2.8	2.1	2.9	2.0	3.1	2.0	3.3	2.0
	40.0	2.4	1.9	2.5	1.9	2.7	1.9	2.8	2.0	2.9	2.0	3.1	2.0	3.3	2.0
43.0	2.4	1.9	2.4	1.9	2.6	1.9	2.7	2.0	2.8	2.0	3.0	2.0	3.2	2.0	
32 (3.6)	20.0	3.4	2.4	3.5	2.5	3.7	2.5	3.9	2.6	4.0	2.6	4.3	2.6	4.5	2.5
	22.5	3.4	2.4	3.5	2.5	3.7	2.5	3.8	2.6	4.0	2.6	4.2	2.6	4.5	2.5
	25.0	3.3	2.4	3.4	2.4	3.7	2.4	3.8	2.6	3.9	2.6	4.2	2.5	4.4	2.5
	27.5	3.3	2.4	3.4	2.4	3.6	2.4	3.8	2.6	3.9	2.5	4.1	2.5	4.4	2.5
	30.0	3.3	2.4	3.3	2.4	3.6	2.4	3.7	2.5	3.8	2.5	4.1	2.5	4.4	2.5
	32.5	3.2	2.3	3.3	2.4	3.5	2.4	3.7	2.5	3.8	2.5	4.1	2.5	4.3	2.5
	35.0	3.2	2.3	3.3	2.4	3.5	2.4	3.6	2.5	3.8	2.5	4.0	2.5	4.3	2.5
	37.5	3.2	2.3	3.2	2.3	3.5	2.3	3.6	2.5	3.7	2.5	4.0	2.5	4.2	2.4
	40.0	3.1	2.3	3.2	2.3	3.4	2.3	3.5	2.5	3.7	2.5	3.9	2.4	4.2	2.4
43.0	3.1	2.3	3.1	2.3	3.4	2.3	3.5	2.4	3.6	2.4	3.9	2.4	4.2	2.4	

kcal/h=kW x 860 , BTU/h = kW x 3,412

1. Cooling [Ceiling concealed (Silent/Slim/High static pressure type)]

PEFY-P-VMS1(L)-E

CA:Capacity(kW) . SHC:Sensible Heat Capacity(kW)

Model size (Rated kW)	Outdoor air temp. °C D.B.	Indoor air temp.													
		21.5°C D.B. 15°C W.B.		23°C D.B. 16°C W.B.		25°C D.B. 18°C W.B.		27°C D.B. 19°C W.B.		28°C D.B. 20°C W.B.		30°C D.B. 22°C W.B.		32°C D.B. 24°C W.B.	
		CA	SHC	CA	SHC	CA	SHC	CA	SHC	CA	SHC	CA	SHC	CA	SHC
15 (1.7)	20.0	1.6	1.5	1.7	1.5	1.8	1.5	1.8	1.6	1.9	1.6	2.0	1.6	2.1	1.6
	22.5	1.6	1.5	1.6	1.5	1.8	1.5	1.8	1.6	1.9	1.6	2.0	1.6	2.1	1.6
	25.0	1.6	1.5	1.6	1.5	1.7	1.5	1.8	1.6	1.8	1.6	2.0	1.6	2.1	1.6
	27.5	1.6	1.4	1.6	1.5	1.7	1.5	1.8	1.6	1.8	1.6	2.0	1.6	2.1	1.6
	30.0	1.5	1.4	1.6	1.5	1.7	1.5	1.8	1.6	1.8	1.6	1.9	1.6	2.1	1.6
	32.5	1.5	1.4	1.6	1.5	1.7	1.5	1.7	1.6	1.8	1.6	1.9	1.6	2.0	1.6
	35.0	1.5	1.4	1.5	1.5	1.7	1.5	1.7	1.6	1.8	1.6	1.9	1.6	2.0	1.6
	37.5	1.5	1.4	1.5	1.5	1.6	1.5	1.7	1.6	1.8	1.6	1.9	1.6	2.0	1.5
	40.0	1.5	1.4	1.5	1.5	1.6	1.5	1.7	1.6	1.7	1.6	1.9	1.6	2.0	1.5
43.0	1.5	1.4	1.5	1.4	1.6	1.4	1.7	1.6	1.7	1.6	1.8	1.5	2.0	1.5	
20 (2.2)	20.0	2.1	1.8	2.1	1.8	2.3	1.8	2.4	2.0	2.4	2.0	2.6	1.9	2.8	1.9
	22.5	2.1	1.8	2.1	1.8	2.3	1.8	2.3	2.0	2.4	1.9	2.6	1.9	2.7	1.9
	25.0	2.0	1.8	2.1	1.8	2.2	1.8	2.3	1.9	2.4	1.9	2.5	1.9	2.7	1.9
	27.5	2.0	1.7	2.1	1.8	2.2	1.8	2.3	1.9	2.4	1.9	2.5	1.9	2.7	1.9
	30.0	2.0	1.7	2.0	1.8	2.2	1.8	2.3	1.9	2.3	1.9	2.5	1.9	2.7	1.9
	32.5	2.0	1.7	2.0	1.8	2.2	1.8	2.2	1.9	2.3	1.9	2.5	1.9	2.6	1.9
	35.0	2.0	1.7	2.0	1.8	2.1	1.8	2.2	1.9	2.3	1.9	2.5	1.9	2.6	1.9
	37.5	1.9	1.7	2.0	1.8	2.1	1.8	2.2	1.9	2.3	1.9	2.4	1.9	2.6	1.9
	40.0	1.9	1.7	1.9	1.8	2.1	1.7	2.2	1.9	2.2	1.9	2.4	1.9	2.6	1.8
43.0	1.9	1.7	1.9	1.7	2.1	1.7	2.1	1.9	2.2	1.9	2.4	1.9	2.5	1.8	
25 (2.8)	20.0	2.6	2.1	2.7	2.2	2.9	2.2	3.0	2.3	3.1	2.3	3.3	2.3	3.5	2.3
	22.5	2.6	2.1	2.7	2.2	2.9	2.2	3.0	2.3	3.1	2.3	3.3	2.3	3.5	2.3
	25.0	2.6	2.1	2.7	2.2	2.9	2.2	2.9	2.3	3.0	2.3	3.2	2.3	3.5	2.2
	27.5	2.6	2.1	2.6	2.2	2.8	2.1	2.9	2.3	3.0	2.3	3.2	2.3	3.4	2.2
	30.0	2.5	2.1	2.6	2.1	2.8	2.1	2.9	2.3	3.0	2.3	3.2	2.3	3.4	2.2
	32.5	2.5	2.1	2.6	2.1	2.8	2.1	2.9	2.3	3.0	2.3	3.2	2.2	3.4	2.2
	35.0	2.5	2.1	2.5	2.1	2.7	2.1	2.8	2.2	2.9	2.2	3.1	2.2	3.3	2.2
	37.5	2.5	2.0	2.5	2.1	2.7	2.1	2.8	2.2	2.9	2.2	3.1	2.2	3.3	2.2
	40.0	2.4	2.0	2.5	2.1	2.7	2.1	2.8	2.2	2.9	2.2	3.1	2.2	3.3	2.2
43.0	2.4	2.0	2.4	2.1	2.6	2.1	2.7	2.2	2.8	2.2	3.0	2.2	3.2	2.2	
32 (3.6)	20.0	3.4	2.6	3.5	2.7	3.7	2.6	3.9	2.8	4.0	2.8	4.3	2.8	4.5	2.7
	22.5	3.4	2.6	3.5	2.6	3.7	2.6	3.8	2.8	4.0	2.8	4.2	2.7	4.5	2.7
	25.0	3.3	2.5	3.4	2.6	3.7	2.6	3.8	2.8	3.9	2.8	4.2	2.7	4.4	2.7
	27.5	3.3	2.5	3.4	2.6	3.6	2.6	3.8	2.7	3.9	2.7	4.1	2.7	4.4	2.7
	30.0	3.3	2.5	3.3	2.6	3.6	2.6	3.7	2.7	3.8	2.7	4.1	2.7	4.4	2.7
	32.5	3.2	2.5	3.3	2.6	3.5	2.5	3.7	2.7	3.8	2.7	4.1	2.7	4.3	2.7
	35.0	3.2	2.5	3.3	2.5	3.5	2.5	3.6	2.7	3.8	2.7	4.0	2.7	4.3	2.6
	37.5	3.2	2.5	3.2	2.5	3.5	2.5	3.6	2.7	3.7	2.7	4.0	2.7	4.2	2.6
	40.0	3.1	2.4	3.2	2.5	3.4	2.5	3.5	2.7	3.7	2.7	3.9	2.6	4.2	2.6
43.0	3.1	2.4	3.1	2.5	3.4	2.5	3.5	2.6	3.6	2.6	3.9	2.6	4.2	2.6	
40 (4.5)	20.0	4.3	3.1	4.4	3.2	4.7	3.2	4.8	3.4	5.0	3.4	5.3	3.3	5.7	3.3
	22.5	4.2	3.1	4.3	3.2	4.6	3.2	4.8	3.4	4.9	3.4	5.3	3.3	5.6	3.3
	25.0	4.2	3.1	4.3	3.2	4.6	3.2	4.7	3.4	4.9	3.3	5.2	3.3	5.6	3.3
	27.5	4.1	3.1	4.2	3.1	4.5	3.1	4.7	3.3	4.8	3.3	5.2	3.3	5.5	3.2
	30.0	4.1	3.1	4.2	3.1	4.5	3.1	4.6	3.3	4.8	3.3	5.1	3.3	5.5	3.2
	32.5	4.0	3.0	4.1	3.1	4.4	3.1	4.6	3.3	4.7	3.3	5.1	3.2	5.4	3.2
	35.0	4.0	3.0	4.1	3.1	4.4	3.1	4.5	3.2	4.7	3.3	5.0	3.2	5.4	3.2
	37.5	4.0	3.0	4.0	3.1	4.3	3.0	4.5	3.2	4.6	3.2	5.0	3.2	5.3	3.2
	40.0	3.9	3.0	4.0	3.0	4.3	3.0	4.4	3.2	4.6	3.2	4.9	3.2	5.3	3.2
43.0	3.9	2.9	3.9	3.0	4.2	3.0	4.4	3.2	4.5	3.2	4.9	3.2	5.2	3.1	
50 (5.6)	20.0	5.3	3.8	5.5	3.9	5.8	3.9	6.0	4.1	6.2	4.1	6.6	4.1	7.0	4.0
	22.5	5.2	3.8	5.4	3.9	5.8	3.9	6.0	4.1	6.2	4.1	6.6	4.1	7.0	4.0
	25.0	5.2	3.8	5.3	3.9	5.7	3.9	5.9	4.1	6.1	4.1	6.5	4.0	6.9	4.0
	27.5	5.1	3.8	5.3	3.9	5.6	3.8	5.8	4.1	6.0	4.0	6.4	4.0	6.9	4.0
	30.0	5.1	3.7	5.2	3.8	5.6	3.8	5.8	4.0	6.0	4.0	6.4	4.0	6.8	3.9
	32.5	5.0	3.7	5.1	3.8	5.5	3.8	5.7	4.0	5.9	4.0	6.3	4.0	6.7	3.9
	35.0	5.0	3.7	5.1	3.8	5.4	3.8	5.6	4.0	5.8	4.0	6.2	3.9	6.7	3.9
	37.5	4.9	3.7	5.0	3.7	5.4	3.7	5.6	4.0	5.8	3.9	6.2	3.9	6.6	3.9
	40.0	4.9	3.6	4.9	3.7	5.3	3.7	5.5	3.9	5.7	3.9	6.1	3.9	6.5	3.8
43.0	4.8	3.6	4.9	3.7	5.2	3.7	5.4	3.9	5.6	3.9	6.0	3.9	6.5	3.8	
63 (7.1)	20.0	6.7	4.9	6.9	5.0	7.4	5.0	7.6	5.2	7.9	5.2	8.4	5.2	8.9	5.1
	22.5	6.6	4.8	6.8	4.9	7.3	4.9	7.6	5.2	7.8	5.2	8.3	5.1	8.8	5.1
	25.0	6.6	4.8	6.8	4.9	7.2	4.9	7.5	5.2	7.7	5.1	8.2	5.1	8.8	5.0
	27.5	6.5	4.8	6.7	4.9	7.2	4.8	7.4	5.1	7.6	5.1	8.2	5.1	8.7	5.0
	30.0	6.4	4.7	6.6	4.8	7.1	4.8	7.3	5.1	7.6	5.1	8.1	5.0	8.6	5.0
	32.5	6.4	4.7	6.5	4.8	7.0	4.8	7.2	5.1	7.5	5.0	8.0	5.0	8.5	4.9
	35.0	6.3	4.7	6.4	4.7	6.9	4.7	7.1	5.0	7.4	5.0	7.9	5.0	8.5	4.9
	37.5	6.2	4.6	6.3	4.7	6.8	4.7	7.1	5.0	7.3	5.0	7.8	4.9	8.4	4.9
	40.0	6.2	4.6	6.3	4.7	6.7	4.7	7.0	5.0	7.2	4.9	7.8	4.9	8.3	4.9
43.0	6.1	4.5	6.2	4.6	6.7	4.6	6.9	4.9	7.1	4.9	7.7	4.9	8.2	4.8	

kcal/h=kW x 860 . BTU/h = kW x 3,412

1. Cooling [Ceiling concealed (Silent/Slim/High static pressure type)]

1-4. Cooling capacity with PUHY-RP700-800YSJM

PEFY-P-VMH-E

CA:Capacity(kW) , SHC:Sensible Heat Capacity(kW)

Model size (Rated kW)	Outdoor air temp.	Indoor air temp.													
		21.5°C D.B. 15°C W.B.		23°C D.B. 16°C W.B.		25°C D.B. 18°C W.B.		27°C D.B. 19°C W.B.		28°C D.B. 20°C W.B.		30°C D.B. 22°C W.B.		32°C D.B. 24°C W.B.	
		°C D.B.	CA	SHC	CA	SHC	CA	SHC	CA	SHC	CA	SHC	CA	SHC	CA
40 (4.5)	20.0	4.3	3.3	4.5	3.4	4.8	3.4	5.0	3.6	5.2	3.6	5.5	3.6	5.9	3.5
	22.5	4.3	3.3	4.4	3.4	4.7	3.4	4.9	3.6	5.1	3.5	5.4	3.5	5.8	3.5
	25.0	4.2	3.2	4.3	3.3	4.7	3.3	4.8	3.5	5.0	3.5	5.3	3.5	5.7	3.4
	27.5	4.1	3.2	4.3	3.3	4.6	3.3	4.7	3.5	4.9	3.5	5.2	3.4	5.6	3.4
	30.0	4.1	3.1	4.2	3.3	4.5	3.2	4.7	3.5	4.8	3.4	5.1	3.4	5.5	3.4
	32.5	4.0	3.1	4.1	3.2	4.4	3.2	4.6	3.4	4.7	3.4	5.0	3.4	5.4	3.3
	35.0	3.9	3.1	4.0	3.2	4.3	3.2	4.5	3.4	4.6	3.4	4.9	3.3	5.3	3.3
	37.5	3.8	3.0	4.0	3.1	4.2	3.1	4.4	3.3	4.5	3.3	4.8	3.3	5.2	3.3
	40.0	3.8	3.0	3.9	3.1	4.2	3.1	4.3	3.3	4.5	3.3	4.8	3.3	5.1	3.2
43.0	3.7	3.0	3.8	3.1	4.1	3.1	4.2	3.3	4.3	3.3	4.6	3.2	4.9	3.2	
50 (5.6)	20.0	5.4	3.9	5.6	4.0	6.0	4.0	6.2	4.2	6.4	4.2	6.9	4.1	7.3	4.1
	22.5	5.3	3.8	5.5	3.9	5.9	3.9	6.1	4.1	6.3	4.1	6.7	4.1	7.2	4.0
	25.0	5.2	3.8	5.4	3.9	5.8	3.9	6.0	4.1	6.2	4.1	6.6	4.0	7.0	4.0
	27.5	5.1	3.7	5.3	3.8	5.7	3.8	5.9	4.0	6.1	4.0	6.5	4.0	6.9	3.9
	30.0	5.0	3.7	5.2	3.8	5.6	3.8	5.8	4.0	6.0	4.0	6.4	3.9	6.8	3.9
	32.5	5.0	3.6	5.1	3.7	5.5	3.7	5.7	3.9	5.9	3.9	6.3	3.9	6.7	3.8
	35.0	4.9	3.6	5.0	3.7	5.4	3.7	5.6	3.9	5.8	3.9	6.2	3.8	6.5	3.8
	37.5	4.8	3.5	4.9	3.6	5.3	3.6	5.5	3.8	5.7	3.8	6.0	3.8	6.4	3.7
	40.0	4.7	3.5	4.8	3.6	5.2	3.6	5.4	3.8	5.5	3.8	5.9	3.8	6.3	3.7
43.0	4.6	3.4	4.7	3.5	5.1	3.5	5.2	3.7	5.4	3.7	5.8	3.7	6.1	3.6	
63 (7.1)	20.0	6.9	5.1	7.1	5.2	7.6	5.2	7.9	5.5	8.2	5.5	8.7	5.5	9.3	5.4
	22.5	6.7	5.0	7.0	5.2	7.5	5.2	7.8	5.5	8.0	5.4	8.6	5.4	9.1	5.3
	25.0	6.6	5.0	6.9	5.1	7.4	5.1	7.6	5.4	7.9	5.4	8.4	5.3	8.9	5.3
	27.5	6.5	4.9	6.7	5.0	7.2	5.0	7.5	5.3	7.7	5.3	8.3	5.3	8.8	5.2
	30.0	6.4	4.8	6.6	5.0	7.1	5.0	7.3	5.3	7.6	5.3	8.1	5.2	8.6	5.1
	32.5	6.3	4.8	6.5	4.9	7.0	4.9	7.2	5.2	7.5	5.2	7.9	5.2	8.5	5.1
	35.0	6.2	4.7	6.4	4.9	6.8	4.9	7.1	5.2	7.3	5.1	7.8	5.1	8.3	5.0
	37.5	6.1	4.7	6.2	4.8	6.7	4.8	6.9	5.1	7.2	5.1	7.6	5.0	8.1	5.0
	40.0	5.9	4.6	6.1	4.8	6.6	4.7	6.8	5.1	7.0	5.0	7.5	5.0	8.0	4.9
43.0	5.8	4.5	6.0	4.7	6.4	4.7	6.6	5.0	6.9	5.0	7.3	4.9	7.8	4.9	
71 (8.0)	20.0	7.7	5.7	8.0	5.8	8.6	5.8	8.9	6.2	9.2	6.1	9.8	6.1	10.4	6.0
	22.5	7.6	5.6	7.9	5.8	8.4	5.8	8.7	6.1	9.0	6.1	9.6	6.0	10.3	5.9
	25.0	7.5	5.5	7.7	5.7	8.3	5.7	8.6	6.0	8.9	6.0	9.5	6.0	10.1	5.9
	27.5	7.3	5.5	7.6	5.6	8.1	5.6	8.4	6.0	8.7	5.9	9.3	5.9	9.9	5.8
	30.0	7.2	5.4	7.4	5.6	8.0	5.6	8.3	5.9	8.6	5.9	9.1	5.8	9.7	5.7
	32.5	7.1	5.3	7.3	5.5	7.8	5.5	8.1	5.8	8.4	5.8	9.0	5.8	9.5	5.7
	35.0	6.9	5.3	7.2	5.4	7.7	5.4	8.0	5.8	8.2	5.7	8.8	5.7	9.3	5.6
	37.5	6.8	5.2	7.0	5.4	7.5	5.4	7.8	5.7	8.1	5.7	8.6	5.6	9.2	5.5
	40.0	6.7	5.1	6.9	5.3	7.4	5.3	7.7	5.6	7.9	5.6	8.4	5.6	9.0	5.5
43.0	6.5	5.1	6.7	5.2	7.2	5.2	7.5	5.6	7.7	5.5	8.2	5.5	8.8	5.4	
80 (9.0)	20.0	8.7	6.4	9.0	6.6	9.7	6.6	10.0	7.0	10.3	7.0	11.0	6.9	11.7	6.8
	22.5	8.5	6.3	8.9	6.5	9.5	6.5	9.8	6.9	10.2	6.9	10.8	6.8	11.5	6.7
	25.0	8.4	6.3	8.7	6.5	9.3	6.4	9.7	6.8	10.0	6.8	10.6	6.7	11.3	6.6
	27.5	8.3	6.2	8.5	6.4	9.2	6.4	9.5	6.8	9.8	6.7	10.5	6.7	11.1	6.6
	30.0	8.1	6.1	8.4	6.3	9.0	6.3	9.3	6.7	9.6	6.7	10.3	6.6	10.9	6.5
	32.5	8.0	6.0	8.2	6.2	8.8	6.2	9.1	6.6	9.4	6.6	10.1	6.5	10.7	6.4
	35.0	7.8	6.0	8.1	6.2	8.7	6.1	9.0	6.5	9.3	6.5	9.9	6.4	10.5	6.4
	37.5	7.7	5.9	7.9	6.1	8.5	6.1	8.8	6.5	9.1	6.4	9.7	6.4	10.3	6.3
	40.0	7.5	5.8	7.7	6.0	8.3	6.0	8.6	6.4	8.9	6.4	9.5	6.3	10.1	6.2
43.0	7.4	5.7	7.6	5.9	8.1	5.9	8.4	6.3	8.7	6.3	9.3	6.2	9.9	6.1	
100 (11.2)	20.0	10.8	8.6	11.2	8.9	12.0	8.9	12.5	9.5	12.9	9.4	13.7	9.3	14.6	9.2
	22.5	10.6	8.5	11.0	8.8	11.8	8.8	12.2	9.4	12.6	9.4	13.5	9.3	14.4	9.1
	25.0	10.5	8.4	10.8	8.7	11.6	8.7	12.0	9.3	12.4	9.3	13.3	9.2	14.1	9.1
	27.5	10.3	8.3	10.6	8.6	11.4	8.6	11.8	9.2	12.2	9.2	13.0	9.1	13.8	9.0
	30.0	10.1	8.3	10.4	8.6	11.2	8.5	11.6	9.1	12.0	9.1	12.8	9.0	13.6	8.9
	32.5	9.9	8.2	10.2	8.5	11.0	8.4	11.4	9.0	11.8	9.0	12.5	8.9	13.3	8.8
	35.0	9.7	8.1	10.0	8.4	10.8	8.3	11.2	9.0	11.5	8.9	12.3	8.8	13.1	8.7
	37.5	9.5	8.0	9.8	8.3	10.6	8.3	10.9	8.9	11.3	8.8	12.1	8.7	12.8	8.6
	40.0	9.4	7.9	9.6	8.2	10.4	8.2	10.7	8.8	11.1	8.7	11.8	8.7	12.6	8.5
43.0	9.2	7.8	9.4	8.1	10.1	8.1	10.5	8.7	10.8	8.6	11.5	8.6	12.3	8.4	
125 (14.0)	20.0	13.5	9.9	14.0	10.3	15.0	10.2	15.6	10.8	16.1	10.8	17.2	10.7	18.3	10.5
	22.5	13.3	9.8	13.8	10.1	14.8	10.1	15.3	10.7	15.8	10.7	16.9	10.6	17.9	10.4
	25.0	13.1	9.7	13.5	10.0	14.5	10.0	15.0	10.6	15.5	10.6	16.6	10.4	17.6	10.3
	27.5	12.8	9.6	13.3	9.9	14.3	9.9	14.8	10.5	15.3	10.4	16.3	10.3	17.3	10.2
	30.0	12.6	9.5	13.0	9.8	14.0	9.7	14.5	10.4	15.0	10.3	16.0	10.2	17.0	10.1
	32.5	12.4	9.4	12.8	9.7	13.7	9.6	14.2	10.2	14.7	10.2	15.7	10.1	16.7	10.0
	35.0	12.2	9.3	12.5	9.5	13.5	9.5	14.0	10.1	14.4	10.1	15.4	10.0	16.4	9.9
	37.5	11.9	9.1	12.3	9.4	13.2	9.4	13.7	10.0	14.1	10.0	15.1	9.9	16.0	9.7
	40.0	11.7	9.0	12.1	9.3	12.9	9.3	13.4	9.9	13.9	9.9	14.8	9.8	15.7	9.6
43.0	11.4	8.9	11.8	9.2	12.6	9.1	13.1	9.7	13.5	9.7	14.4	9.6	15.4	9.5	

kcal/h=kW x 860 , BTU/h = kW x 3,412

1. Cooling [Ceiling concealed (Silent/Slim/High static pressure type)]

PEFY-P-VMH-E

CA:Capacity(kW) , SHC:Sensible Heat Capacity(kW)

Model size (Rated kW)	Outdoor air temp. °C D.B.	Indoor air temp.													
		21.5°C D.B. 15°C W.B.		23°C D.B. 16°C W.B.		25°C D.B. 18°C W.B.		27°C D.B. 19°C W.B.		28°C D.B. 20°C W.B.		30°C D.B. 22°C W.B.		32°C D.B. 24°C W.B.	
		CA	SHC	CA	SHC	CA	SHC	CA	SHC	CA	SHC	CA	SHC	CA	SHC
140 (16.0)	20.0	15.5	11.4	16.0	11.7	17.2	11.7	17.8	12.4	18.4	12.3	19.6	12.2	20.9	12.1
	22.5	15.2	11.2	15.7	11.6	16.9	11.6	17.5	12.2	18.1	12.2	19.3	12.1	20.5	11.9
	25.0	14.9	11.1	15.5	11.4	16.6	11.4	17.2	12.1	17.8	12.1	18.9	11.9	20.1	11.8
	27.5	14.7	11.0	15.2	11.3	16.3	11.3	16.9	12.0	17.4	11.9	18.6	11.8	19.8	11.7
	30.0	14.4	10.8	14.9	11.2	16.0	11.1	16.6	11.8	17.1	11.8	18.3	11.7	19.4	11.5
	32.5	14.2	10.7	14.6	11.0	15.7	11.0	16.2	11.7	16.8	11.7	17.9	11.5	19.1	11.4
	35.0	13.9	10.6	14.3	10.9	15.4	10.9	16.0	11.6	16.5	11.5	17.6	11.4	18.7	11.3
	37.5	13.6	10.5	14.1	10.8	15.1	10.7	15.6	11.4	16.2	11.4	17.2	11.3	18.3	11.1
	40.0	13.4	10.3	13.8	10.6	14.8	10.6	15.3	11.3	15.8	11.3	16.9	11.2	18.0	11.0
43.0	13.1	10.2	13.4	10.5	14.4	10.5	14.9	11.1	15.5	11.1	16.5	11.0	17.6	10.9	
200 (22.4)	20.0	21.6	16.3	22.4	16.8	24.1	16.7	24.9	17.8	25.7	17.7	27.5	17.5	29.2	17.3
	22.5	21.3	16.1	22.0	16.6	23.6	16.6	24.5	17.6	25.3	17.5	27.0	17.4	28.7	17.1
	25.0	20.9	15.9	21.6	16.4	23.2	16.4	24.0	17.4	24.9	17.3	26.5	17.2	28.2	16.9
	27.5	20.5	15.7	21.3	16.2	22.8	16.2	23.6	17.2	24.4	17.2	26.0	17.0	27.7	16.8
	30.0	20.2	15.5	20.9	16.1	22.4	16.0	23.2	17.0	24.0	17.0	25.6	16.8	27.2	16.6
	32.5	19.8	15.4	20.5	15.9	22.0	15.8	22.7	16.9	23.5	16.8	25.1	16.6	26.7	16.4
	35.0	19.5	15.2	20.1	15.7	21.5	15.6	22.4	16.7	23.1	16.6	24.6	16.4	26.2	16.2
	37.5	19.1	15.0	19.7	15.5	21.1	15.5	21.9	16.5	22.6	16.4	24.1	16.3	25.7	16.1
	40.0	18.7	14.9	19.3	15.3	20.7	15.3	21.4	16.3	22.2	16.2	23.7	16.1	25.2	15.9
43.0	18.3	14.6	18.8	15.1	20.2	15.1	20.9	16.1	21.6	16.0	23.1	15.9	24.6	15.7	
250 (28.0)	20.0	27.0	20.2	28.0	20.9	30.1	20.8	31.1	22.1	32.2	22.0	34.3	21.8	36.5	21.5
	22.5	26.6	20.0	27.5	20.7	29.6	20.6	30.6	21.9	31.6	21.8	33.7	21.6	35.9	21.3
	25.0	26.1	19.8	27.1	20.4	29.0	20.4	30.0	21.6	31.1	21.5	33.1	21.3	35.2	21.1
	27.5	25.7	19.5	26.6	20.2	28.5	20.1	29.5	21.4	30.5	21.3	32.5	21.1	34.6	20.8
	30.0	25.2	19.3	26.1	19.9	28.0	19.9	29.0	21.2	29.9	21.1	31.9	20.9	34.0	20.6
	32.5	24.8	19.1	25.6	19.7	27.5	19.7	28.4	20.9	29.4	20.9	31.4	20.6	33.4	20.4
	35.0	24.3	18.9	25.1	19.5	26.9	19.4	28.0	20.7	28.8	20.6	30.8	20.4	32.7	20.2
	37.5	23.9	18.7	24.6	19.3	26.4	19.2	27.3	20.5	28.3	20.4	30.2	20.2	32.1	19.9
	40.0	23.4	18.5	24.1	19.0	25.9	19.0	26.8	20.2	27.7	20.2	29.6	20.0	31.5	19.7
43.0	22.9	18.2	23.5	18.8	25.3	18.7	26.2	20.0	27.0	19.9	28.9	19.7	30.7	19.5	

kcal/h=kW x 860 , BTU/h = kW x 3,412

1. Cooling [Ceiling concealed (Silent/Slim/High static pressure type)]

PEFY-P-VMR-E-L/R

CA:Capacity(kW) , SHC:Sensible Heat Capacity(kW)

Model size (Rated kW)	Outdoor air temp. °C D.B.	Indoor air temp.													
		21.5°C D.B. 15°C W.B.		23°C D.B. 16°C W.B.		25°C D.B. 18°C W.B.		27°C D.B. 19°C W.B.		28°C D.B. 20°C W.B.		30°C D.B. 22°C W.B.		32°C D.B. 24°C W.B.	
		CA	SHC	CA	SHC	CA	SHC	CA	SHC	CA	SHC	CA	SHC	CA	SHC
20 (2.2)	20.0	2.1	1.7	2.2	1.8	2.4	1.8	2.4	1.9	2.5	1.9	2.7	1.9	2.9	1.9
	22.5	2.1	1.7	2.2	1.8	2.3	1.8	2.4	1.9	2.5	1.9	2.6	1.9	2.8	1.8
	25.0	2.1	1.7	2.1	1.8	2.3	1.8	2.4	1.9	2.4	1.9	2.6	1.8	2.8	1.8
	27.5	2.0	1.7	2.1	1.7	2.2	1.7	2.3	1.9	2.4	1.9	2.6	1.8	2.7	1.8
	30.0	2.0	1.7	2.0	1.7	2.2	1.7	2.3	1.8	2.4	1.8	2.5	1.8	2.7	1.8
	32.5	1.9	1.6	2.0	1.7	2.2	1.7	2.2	1.8	2.3	1.8	2.5	1.8	2.6	1.8
	35.0	1.9	1.6	2.0	1.7	2.1	1.7	2.2	1.8	2.3	1.8	2.4	1.8	2.6	1.8
	37.5	1.9	1.6	1.9	1.7	2.1	1.7	2.1	1.8	2.2	1.8	2.4	1.8	2.5	1.7
	40.0	1.8	1.6	1.9	1.7	2.0	1.6	2.1	1.8	2.2	1.8	2.3	1.7	2.5	1.7
43.0	1.8	1.6	1.8	1.6	2.0	1.6	2.1	1.8	2.1	1.7	2.3	1.7	2.4	1.7	
25 (2.8)	20.0	2.7	2.0	2.8	2.1	3.0	2.1	3.1	2.2	3.2	2.2	3.4	2.2	3.7	2.1
	22.5	2.7	2.0	2.8	2.1	3.0	2.0	3.1	2.2	3.2	2.2	3.4	2.1	3.6	2.1
	25.0	2.6	2.0	2.7	2.0	2.9	2.0	3.0	2.1	3.1	2.1	3.3	2.1	3.5	2.1
	27.5	2.6	1.9	2.7	2.0	2.9	2.0	3.0	2.1	3.1	2.1	3.3	2.1	3.5	2.1
	30.0	2.5	1.9	2.6	2.0	2.8	2.0	2.9	2.1	3.0	2.1	3.2	2.1	3.4	2.0
	32.5	2.5	1.9	2.6	2.0	2.7	2.0	2.8	2.1	2.9	2.1	3.1	2.0	3.3	2.0
	35.0	2.4	1.9	2.5	1.9	2.7	1.9	2.8	2.1	2.9	2.0	3.1	2.0	3.3	2.0
	37.5	2.4	1.9	2.5	1.9	2.6	1.9	2.7	2.0	2.8	2.0	3.0	2.0	3.2	2.0
	40.0	2.3	1.8	2.4	1.9	2.6	1.9	2.7	2.0	2.8	2.0	3.0	2.0	3.1	2.0
43.0	2.3	1.8	2.4	1.9	2.5	1.9	2.6	2.0	2.7	2.0	2.9	2.0	3.1	1.9	
32 (3.6)	20.0	3.5	2.5	3.6	2.5	3.9	2.5	4.0	2.7	4.1	2.7	4.4	2.6	4.7	2.6
	22.5	3.4	2.4	3.5	2.5	3.8	2.5	3.9	2.6	4.1	2.6	4.3	2.6	4.6	2.6
	25.0	3.4	2.4	3.5	2.5	3.7	2.5	3.9	2.6	4.0	2.6	4.3	2.6	4.5	2.5
	27.5	3.3	2.4	3.4	2.4	3.7	2.4	3.8	2.6	3.9	2.6	4.2	2.5	4.5	2.5
	30.0	3.2	2.3	3.4	2.4	3.6	2.4	3.7	2.5	3.9	2.5	4.1	2.5	4.4	2.5
	32.5	3.2	2.3	3.3	2.4	3.5	2.4	3.7	2.5	3.8	2.5	4.0	2.5	4.3	2.5
	35.0	3.1	2.3	3.2	2.4	3.5	2.3	3.6	2.5	3.7	2.5	4.0	2.5	4.2	2.4
	37.5	3.1	2.3	3.2	2.3	3.4	2.3	3.5	2.5	3.6	2.4	3.9	2.4	4.1	2.4
	40.0	3.0	2.2	3.1	2.3	3.3	2.3	3.4	2.4	3.6	2.4	3.8	2.4	4.0	2.4
43.0	2.9	2.2	3.0	2.3	3.2	2.2	3.4	2.4	3.5	2.4	3.7	2.4	3.9	2.3	

kcal/h=kW x 860 , BTU/h = kW x 3,412

1. Cooling [Ceiling concealed (Silent/Slim/High static pressure type)]

PEFY-P-VMS1(L)-E

CA:Capacity(kW) , SHC:Sensible Heat Capacity(kW)

Model size (Rated kW)	Outdoor air temp. °C D.B.	Indoor air temp.													
		21.5°C D.B. 15°C W.B.		23°C D.B. 16°C W.B.		25°C D.B. 18°C W.B.		27°C D.B. 19°C W.B.		28°C D.B. 20°C W.B.		30°C D.B. 22°C W.B.		32°C D.B. 24°C W.B.	
		CA	SHC	CA	SHC	CA	SHC	CA	SHC	CA	SHC	CA	SHC	CA	SHC
15 (1.7)	20.0	1.6	1.5	1.7	1.5	1.8	1.5	1.9	1.7	2.0	1.6	2.1	1.6	2.2	1.6
	22.5	1.6	1.5	1.7	1.5	1.8	1.5	1.9	1.6	1.9	1.6	2.0	1.6	2.2	1.6
	25.0	1.6	1.5	1.6	1.5	1.8	1.5	1.8	1.6	1.9	1.6	2.0	1.6	2.1	1.6
	27.5	1.6	1.4	1.6	1.5	1.7	1.5	1.8	1.6	1.9	1.6	2.0	1.6	2.1	1.6
	30.0	1.5	1.4	1.6	1.5	1.7	1.5	1.8	1.6	1.8	1.6	1.9	1.6	2.1	1.6
	32.5	1.5	1.4	1.6	1.5	1.7	1.5	1.7	1.6	1.8	1.6	1.9	1.6	2.0	1.6
	35.0	1.5	1.4	1.5	1.5	1.6	1.5	1.7	1.6	1.8	1.6	1.9	1.6	2.0	1.5
	37.5	1.4	1.4	1.5	1.5	1.6	1.4	1.7	1.6	1.7	1.6	1.8	1.5	1.9	1.5
	40.0	1.4	1.4	1.5	1.4	1.6	1.4	1.6	1.6	1.7	1.5	1.8	1.5	1.9	1.5
43.0	1.4	1.4	1.4	1.4	1.5	1.4	1.6	1.5	1.6	1.5	1.8	1.5	1.9	1.5	
20 (2.2)	20.0	2.1	1.8	2.2	1.9	2.4	1.9	2.4	2.0	2.5	2.0	2.7	2.0	2.9	1.9
	22.5	2.1	1.8	2.2	1.8	2.3	1.8	2.4	2.0	2.5	2.0	2.6	1.9	2.8	1.9
	25.0	2.1	1.8	2.1	1.8	2.3	1.8	2.4	2.0	2.4	2.0	2.6	1.9	2.8	1.9
	27.5	2.0	1.7	2.1	1.8	2.2	1.8	2.3	1.9	2.4	1.9	2.6	1.9	2.7	1.9
	30.0	2.0	1.7	2.0	1.8	2.2	1.8	2.3	1.9	2.4	1.9	2.5	1.9	2.7	1.9
	32.5	1.9	1.7	2.0	1.8	2.2	1.8	2.2	1.9	2.3	1.9	2.5	1.9	2.6	1.9
	35.0	1.9	1.7	2.0	1.8	2.1	1.8	2.2	1.9	2.3	1.9	2.4	1.9	2.6	1.8
	37.5	1.9	1.7	1.9	1.7	2.1	1.7	2.1	1.9	2.2	1.9	2.4	1.9	2.5	1.8
	40.0	1.8	1.7	1.9	1.7	2.0	1.7	2.1	1.9	2.2	1.9	2.3	1.8	2.5	1.8
43.0	1.8	1.6	1.8	1.7	2.0	1.7	2.1	1.8	2.1	1.8	2.3	1.8	2.4	1.8	
25 (2.8)	20.0	2.7	2.2	2.8	2.2	3.0	2.2	3.1	2.4	3.2	2.4	3.4	2.3	3.7	2.3
	22.5	2.7	2.1	2.8	2.2	3.0	2.2	3.1	2.4	3.2	2.3	3.4	2.3	3.6	2.3
	25.0	2.6	2.1	2.7	2.2	2.9	2.2	3.0	2.3	3.1	2.3	3.3	2.3	3.5	2.3
	27.5	2.6	2.1	2.7	2.2	2.9	2.2	3.0	2.3	3.1	2.3	3.3	2.3	3.5	2.2
	30.0	2.5	2.1	2.6	2.1	2.8	2.1	2.9	2.3	3.0	2.3	3.2	2.3	3.4	2.2
	32.5	2.5	2.1	2.6	2.1	2.7	2.1	2.8	2.3	2.9	2.3	3.1	2.2	3.3	2.2
	35.0	2.4	2.0	2.5	2.1	2.7	2.1	2.8	2.2	2.9	2.2	3.1	2.2	3.3	2.2
	37.5	2.4	2.0	2.5	2.1	2.6	2.1	2.7	2.2	2.8	2.2	3.0	2.2	3.2	2.2
	40.0	2.3	2.0	2.4	2.1	2.6	2.0	2.7	2.2	2.8	2.2	3.0	2.2	3.1	2.1
43.0	2.3	2.0	2.4	2.0	2.5	2.0	2.6	2.2	2.7	2.2	2.9	2.1	3.1	2.1	
32 (3.6)	20.0	3.5	2.6	3.6	2.7	3.9	2.7	4.0	2.9	4.1	2.8	4.4	2.8	4.7	2.8
	22.5	3.4	2.6	3.5	2.7	3.8	2.7	3.9	2.8	4.1	2.8	4.3	2.8	4.6	2.8
	25.0	3.4	2.6	3.5	2.6	3.7	2.6	3.9	2.8	4.0	2.8	4.3	2.8	4.5	2.7
	27.5	3.3	2.5	3.4	2.6	3.7	2.6	3.8	2.8	3.9	2.8	4.2	2.7	4.5	2.7
	30.0	3.2	2.5	3.4	2.6	3.6	2.6	3.7	2.7	3.9	2.7	4.1	2.7	4.4	2.7
	32.5	3.2	2.5	3.3	2.6	3.5	2.5	3.7	2.7	3.8	2.7	4.0	2.7	4.3	2.6
	35.0	3.1	2.4	3.2	2.5	3.5	2.5	3.6	2.7	3.7	2.7	4.0	2.6	4.2	2.6
	37.5	3.1	2.4	3.2	2.5	3.4	2.5	3.5	2.7	3.6	2.6	3.9	2.6	4.1	2.6
	40.0	3.0	2.4	3.1	2.5	3.3	2.5	3.4	2.6	3.6	2.6	3.8	2.6	4.0	2.6
43.0	2.9	2.4	3.0	2.4	3.2	2.4	3.4	2.6	3.5	2.6	3.7	2.6	3.9	2.5	
40 (4.5)	20.0	4.3	3.2	4.5	3.3	4.8	3.3	5.0	3.5	5.2	3.5	5.5	3.4	5.9	3.4
	22.5	4.3	3.1	4.4	3.2	4.7	3.2	4.9	3.4	5.1	3.4	5.4	3.4	5.8	3.3
	25.0	4.2	3.1	4.3	3.2	4.7	3.2	4.8	3.4	5.0	3.4	5.3	3.3	5.7	3.3
	27.5	4.1	3.1	4.3	3.2	4.6	3.2	4.7	3.4	4.9	3.3	5.2	3.3	5.6	3.3
	30.0	4.1	3.0	4.2	3.1	4.5	3.1	4.7	3.3	4.8	3.3	5.1	3.3	5.5	3.2
	32.5	4.0	3.0	4.1	3.1	4.4	3.1	4.6	3.3	4.7	3.3	5.0	3.2	5.4	3.2
	35.0	3.9	3.0	4.0	3.1	4.3	3.0	4.5	3.2	4.6	3.2	4.9	3.2	5.3	3.2
	37.5	3.8	2.9	4.0	3.0	4.2	3.0	4.4	3.2	4.5	3.2	4.8	3.2	5.2	3.1
	40.0	3.8	2.9	3.9	3.0	4.2	3.0	4.3	3.2	4.5	3.2	4.8	3.1	5.1	3.1
43.0	3.7	2.9	3.8	2.9	4.1	2.9	4.2	3.1	4.3	3.1	4.6	3.1	4.9	3.0	
50 (5.6)	20.0	5.4	3.9	5.6	4.0	6.0	4.0	6.2	4.2	6.4	4.2	6.9	4.2	7.3	4.1
	22.5	5.3	3.9	5.5	4.0	5.9	4.0	6.1	4.2	6.3	4.2	6.7	4.1	7.2	4.1
	25.0	5.2	3.8	5.4	3.9	5.8	3.9	6.0	4.1	6.2	4.1	6.6	4.1	7.0	4.0
	27.5	5.1	3.8	5.3	3.9	5.7	3.9	5.9	4.1	6.1	4.1	6.5	4.0	6.9	4.0
	30.0	5.0	3.7	5.2	3.8	5.6	3.8	5.8	4.0	6.0	4.0	6.4	4.0	6.8	3.9
	32.5	5.0	3.7	5.1	3.8	5.5	3.8	5.7	4.0	5.9	4.0	6.3	3.9	6.7	3.9
	35.0	4.9	3.6	5.0	3.7	5.4	3.7	5.6	4.0	5.8	3.9	6.2	3.9	6.5	3.8
	37.5	4.8	3.6	4.9	3.7	5.3	3.7	5.5	3.9	5.7	3.9	6.0	3.9	6.4	3.8
	40.0	4.7	3.5	4.8	3.6	5.2	3.6	5.4	3.9	5.5	3.8	5.9	3.8	6.3	3.8
43.0	4.6	3.5	4.7	3.6	5.1	3.6	5.2	3.8	5.4	3.8	5.8	3.8	6.1	3.7	
63 (7.1)	20.0	6.9	4.9	7.1	5.1	7.6	5.1	7.9	5.4	8.2	5.3	8.7	5.3	9.3	5.2
	22.5	6.7	4.9	7.0	5.0	7.5	5.0	7.8	5.3	8.0	5.3	8.6	5.2	9.1	5.2
	25.0	6.6	4.8	6.9	5.0	7.4	4.9	7.6	5.2	7.9	5.2	8.4	5.2	8.9	5.1
	27.5	6.5	4.8	6.7	4.9	7.2	4.9	7.5	5.2	7.7	5.2	8.3	5.1	8.8	5.0
	30.0	6.4	4.7	6.6	4.8	7.1	4.8	7.3	5.1	7.6	5.1	8.1	5.0	8.6	5.0
	32.5	6.3	4.6	6.5	4.8	7.0	4.8	7.2	5.0	7.5	5.0	7.9	5.0	8.5	4.9
	35.0	6.2	4.6	6.4	4.7	6.8	4.7	7.1	5.0	7.3	5.0	7.8	4.9	8.3	4.9
	37.5	6.1	4.5	6.2	4.7	6.7	4.6	6.9	4.9	7.2	4.9	7.6	4.9	8.1	4.8
	40.0	5.9	4.5	6.1	4.6	6.6	4.6	6.8	4.9	7.0	4.9	7.5	4.8	8.0	4.7
43.0	5.8	4.4	6.0	4.5	6.4	4.5	6.6	4.8	6.9	4.8	7.3	4.7	7.8	4.7	

kcal/h = kW x 860 , BTU/h = kW x 3,412

1. Cooling [Ceiling concealed (Silent/Slim/High static pressure type)]

1-5. Cooling capacity with PUHY-RP850-900YSJM

PEFY-P-VMH-E

CA:Capacity(kW) , SHC:Sensible Heat Capacity(kW)

Model size (Rated kW)	Outdoor air temp. °C D.B.	Indoor air temp.													
		21.5°C D.B. 15°C W.B.		23°C D.B. 16°C W.B.		25°C D.B. 18°C W.B.		27°C D.B. 19°C W.B.		28°C D.B. 20°C W.B.		30°C D.B. 22°C W.B.		32°C D.B. 24°C W.B.	
		CA	SHC	CA	SHC	CA	SHC	CA	SHC	CA	SHC	CA	SHC	CA	SHC
40 (4.5)	20.0	4.3	3.2	4.4	3.3	4.7	3.3	4.8	3.5	5.0	3.5	5.3	3.5	5.7	3.4
	22.5	4.2	3.2	4.3	3.3	4.6	3.3	4.8	3.5	4.9	3.5	5.3	3.5	5.6	3.4
	25.0	4.2	3.2	4.3	3.3	4.6	3.3	4.7	3.5	4.9	3.5	5.2	3.4	5.6	3.4
	27.5	4.1	3.2	4.2	3.3	4.5	3.3	4.7	3.5	4.8	3.5	5.2	3.4	5.5	3.4
	30.0	4.1	3.2	4.2	3.2	4.5	3.2	4.6	3.4	4.8	3.4	5.1	3.4	5.5	3.4
	32.5	4.0	3.1	4.1	3.2	4.4	3.2	4.6	3.4	4.7	3.4	5.1	3.4	5.4	3.3
	35.0	4.0	3.1	4.1	3.2	4.4	3.2	4.5	3.4	4.7	3.4	5.0	3.4	5.4	3.3
	37.5	4.0	3.1	4.0	3.2	4.3	3.2	4.5	3.4	4.6	3.4	5.0	3.3	5.3	3.3
	40.0	3.9	3.1	4.0	3.1	4.3	3.1	4.4	3.4	4.6	3.3	4.9	3.3	5.3	3.3
43.0	3.9	3.1	3.9	3.1	4.2	3.1	4.4	3.3	4.5	3.3	4.9	3.3	5.2	3.3	
50 (5.6)	20.0	5.3	3.8	5.5	3.9	5.8	3.9	6.0	4.1	6.2	4.1	6.6	4.0	7.0	4.0
	22.5	5.2	3.8	5.4	3.9	5.8	3.9	6.0	4.1	6.2	4.1	6.6	4.0	7.0	4.0
	25.0	5.2	3.7	5.3	3.8	5.7	3.8	5.9	4.0	6.1	4.0	6.5	4.0	6.9	3.9
	27.5	5.1	3.7	5.3	3.8	5.6	3.8	5.8	4.0	6.0	4.0	6.4	4.0	6.9	3.9
	30.0	5.1	3.7	5.2	3.8	5.6	3.8	5.8	4.0	6.0	4.0	6.4	3.9	6.8	3.9
	32.5	5.0	3.7	5.1	3.7	5.5	3.7	5.7	4.0	5.9	3.9	6.3	3.9	6.7	3.9
	35.0	5.0	3.6	5.1	3.7	5.4	3.7	5.6	3.9	5.8	3.9	6.2	3.9	6.7	3.8
	37.5	4.9	3.6	5.0	3.7	5.4	3.7	5.6	3.9	5.8	3.9	6.2	3.9	6.6	3.8
	40.0	4.9	3.6	4.9	3.6	5.3	3.6	5.5	3.9	5.7	3.9	6.1	3.8	6.5	3.8
43.0	4.8	3.6	4.9	3.6	5.2	3.6	5.4	3.8	5.6	3.8	6.0	3.8	6.5	3.8	
63 (7.1)	20.0	6.7	5.0	6.9	5.1	7.4	5.1	7.6	5.4	7.9	5.4	8.4	5.3	8.9	5.3
	22.5	6.6	5.0	6.8	5.1	7.3	5.1	7.6	5.4	7.8	5.4	8.3	5.3	8.8	5.2
	25.0	6.6	4.9	6.8	5.1	7.2	5.0	7.5	5.3	7.7	5.3	8.2	5.3	8.8	5.2
	27.5	6.5	4.9	6.7	5.0	7.2	5.0	7.4	5.3	7.6	5.3	8.2	5.2	8.7	5.2
	30.0	6.4	4.9	6.6	5.0	7.1	5.0	7.3	5.3	7.6	5.3	8.1	5.2	8.6	5.1
	32.5	6.4	4.8	6.5	4.9	7.0	4.9	7.2	5.2	7.5	5.2	8.0	5.2	8.5	5.1
	35.0	6.3	4.8	6.4	4.9	6.9	4.9	7.1	5.2	7.4	5.2	7.9	5.1	8.5	5.1
	37.5	6.2	4.8	6.3	4.9	6.8	4.9	7.1	5.2	7.3	5.2	7.8	5.1	8.4	5.1
	40.0	6.2	4.7	6.3	4.8	6.7	4.8	7.0	5.1	7.2	5.1	7.8	5.1	8.3	5.0
43.0	6.1	4.7	6.2	4.8	6.7	4.8	6.9	5.1	7.1	5.1	7.7	5.0	8.2	5.0	
71 (8.0)	20.0	7.6	5.6	7.8	5.7	8.3	5.7	8.6	6.0	8.9	6.0	9.4	5.9	10.0	5.9
	22.5	7.5	5.5	7.7	5.7	8.2	5.7	8.5	6.0	8.8	6.0	9.4	5.9	10.0	5.8
	25.0	7.4	5.5	7.6	5.6	8.1	5.6	8.4	6.0	8.7	5.9	9.3	5.9	9.9	5.8
	27.5	7.3	5.5	7.5	5.6	8.1	5.6	8.3	5.9	8.6	5.9	9.2	5.8	9.8	5.8
	30.0	7.3	5.4	7.4	5.6	8.0	5.5	8.2	5.9	8.5	5.9	9.1	5.8	9.7	5.7
	32.5	7.2	5.4	7.3	5.5	7.9	5.5	8.2	5.8	8.4	5.8	9.0	5.8	9.6	5.7
	35.0	7.1	5.4	7.2	5.5	7.8	5.5	8.0	5.8	8.3	5.8	8.9	5.7	9.5	5.7
	37.5	7.0	5.3	7.2	5.4	7.7	5.4	8.0	5.8	8.3	5.7	8.8	5.7	9.4	5.6
	40.0	7.0	5.3	7.1	5.4	7.6	5.4	7.9	5.7	8.2	5.7	8.7	5.7	9.4	5.6
43.0	6.9	5.2	7.0	5.3	7.5	5.3	7.8	5.7	8.1	5.7	8.6	5.6	9.2	5.6	
80 (9.0)	20.0	8.5	6.3	8.8	6.5	9.4	6.5	9.7	6.8	10.0	6.8	10.6	6.7	11.3	6.6
	22.5	8.4	6.3	8.7	6.4	9.3	6.4	9.6	6.8	9.9	6.8	10.5	6.7	11.2	6.6
	25.0	8.3	6.2	8.6	6.4	9.2	6.4	9.5	6.8	9.8	6.7	10.4	6.7	11.1	6.6
	27.5	8.3	6.2	8.5	6.3	9.1	6.3	9.4	6.7	9.7	6.7	10.3	6.6	11.0	6.5
	30.0	8.2	6.1	8.4	6.3	9.0	6.3	9.3	6.7	9.6	6.6	10.2	6.6	10.9	6.5
	32.5	8.1	6.1	8.3	6.2	8.9	6.2	9.2	6.6	9.5	6.6	10.1	6.5	10.8	6.5
	35.0	8.0	6.1	8.1	6.2	8.8	6.2	9.0	6.5	9.4	6.6	10.0	6.5	10.7	6.4
	37.5	7.9	6.0	8.0	6.1	8.7	6.1	9.0	6.5	9.3	6.5	9.9	6.5	10.6	6.4
	40.0	7.8	6.0	7.9	6.1	8.6	6.1	8.9	6.5	9.2	6.5	9.8	6.4	10.5	6.4
43.0	7.7	5.9	7.8	6.0	8.4	6.0	8.7	6.4	9.1	6.4	9.7	6.4	10.4	6.3	
100 (11.2)	20.0	10.6	8.5	10.9	8.8	11.7	8.7	12.0	9.3	12.4	9.3	13.2	9.2	14.1	9.0
	22.5	10.5	8.4	10.8	8.7	11.5	8.7	11.9	9.3	12.3	9.2	13.1	9.1	13.9	9.0
	25.0	10.4	8.4	10.6	8.7	11.4	8.6	11.8	9.2	12.2	9.2	13.0	9.1	13.8	9.0
	27.5	10.3	8.3	10.5	8.6	11.3	8.6	11.7	9.2	12.1	9.1	12.9	9.0	13.7	8.9
	30.0	10.2	8.3	10.4	8.5	11.2	8.5	11.5	9.1	11.9	9.1	12.7	9.0	13.6	8.9
	32.5	10.1	8.2	10.3	8.5	11.0	8.5	11.4	9.0	11.8	9.0	12.6	8.9	13.5	8.8
	35.0	9.9	8.2	10.1	8.4	10.9	8.4	11.2	9.0	11.7	9.0	12.5	8.9	13.3	8.8
	37.5	9.8	8.1	10.0	8.4	10.8	8.3	11.2	8.9	11.6	8.9	12.4	8.8	13.2	8.8
	40.0	9.7	8.1	9.9	8.3	10.6	8.3	11.0	8.9	11.4	8.9	12.2	8.8	13.1	8.7
43.0	9.6	8.0	9.7	8.2	10.5	8.2	10.9	8.8	11.3	8.8	12.1	8.7	12.9	8.7	
125 (14.0)	20.0	13.2	9.8	13.6	10.1	14.6	10.0	15.1	10.6	15.5	10.6	16.5	10.4	17.6	10.3
	22.5	13.1	9.7	13.5	10.0	14.4	9.9	14.9	10.5	15.4	10.5	16.4	10.4	17.4	10.2
	25.0	13.0	9.7	13.3	9.9	14.3	9.9	14.7	10.5	15.2	10.4	16.2	10.3	17.3	10.2
	27.5	12.8	9.6	13.2	9.8	14.1	9.8	14.6	10.4	15.1	10.4	16.1	10.3	17.1	10.1
	30.0	12.7	9.5	13.0	9.8	13.9	9.7	14.4	10.3	14.9	10.3	15.9	10.2	17.0	10.1
	32.5	12.6	9.5	12.8	9.7	13.8	9.7	14.3	10.3	14.8	10.2	15.8	10.1	16.8	10.0
	35.0	12.4	9.4	12.7	9.6	13.6	9.6	14.0	10.1	14.6	10.2	15.6	10.1	16.7	10.0
	37.5	12.3	9.3	12.5	9.5	13.5	9.5	14.0	10.1	14.4	10.1	15.5	10.0	16.5	9.9
	40.0	12.2	9.3	12.4	9.5	13.3	9.4	13.8	10.1	14.3	10.0	15.3	10.0	16.4	9.9
43.0	12.0	9.2	12.2	9.4	13.1	9.4	13.6	10.0	14.1	9.9	15.1	9.9	16.2	9.8	

kcal/h=kW x 860 , BTU/h = kW x 3,412

1. Cooling [Ceiling concealed (Silent/Slim/High static pressure type)]

PEFY-P-VMH-E

CA:Capacity(kW) , SHC:Sensible Heat Capacity(kW)

Model size (Rated kW)	Outdoor air temp. °C D.B.	Indoor air temp.													
		21.5°C D.B. 15°C W.B.		23°C D.B. 16°C W.B.		25°C D.B. 18°C W.B.		27°C D.B. 19°C W.B.		28°C D.B. 20°C W.B.		30°C D.B. 22°C W.B.		32°C D.B. 24°C W.B.	
		CA	SHC	CA	SHC	CA	SHC	CA	SHC	CA	SHC	CA	SHC	CA	SHC
140 (16.0)	20.0	15.1	11.2	15.6	11.5	16.7	11.4	17.2	12.1	17.8	12.1	18.9	11.9	20.1	11.8
	22.5	15.0	11.1	15.4	11.4	16.5	11.4	17.0	12.0	17.6	12.0	18.7	11.9	19.9	11.7
	25.0	14.8	11.0	15.2	11.3	16.3	11.3	16.8	12.0	17.4	11.9	18.5	11.8	19.7	11.6
	27.5	14.7	11.0	15.0	11.2	16.1	11.2	16.7	11.9	17.2	11.8	18.4	11.7	19.6	11.6
	30.0	14.5	10.9	14.9	11.2	15.9	11.1	16.5	11.8	17.0	11.8	18.2	11.7	19.4	11.5
	32.5	14.4	10.8	14.7	11.1	15.8	11.0	16.3	11.7	16.9	11.7	18.0	11.6	19.2	11.5
	35.0	14.2	10.7	14.5	11.0	15.6	11.0	16.0	11.6	16.7	11.6	17.8	11.5	19.1	11.4
	37.5	14.1	10.7	14.3	10.9	15.4	10.9	15.9	11.6	16.5	11.5	17.7	11.4	18.9	11.3
	40.0	13.9	10.6	14.1	10.8	15.2	10.8	15.8	11.5	16.3	11.5	17.5	11.4	18.7	11.3
43.0	13.7	10.5	13.9	10.7	15.0	10.7	15.6	11.4	16.1	11.4	17.3	11.3	18.5	11.2	
200 (22.4)	20.0	21.2	16.0	21.8	16.5	23.3	16.4	24.1	17.4	24.9	17.3	26.5	17.1	28.1	16.9
	22.5	21.0	15.9	21.6	16.4	23.1	16.3	23.8	17.3	24.6	17.2	26.2	17.1	27.9	16.8
	25.0	20.7	15.8	21.3	16.3	22.8	16.2	23.6	17.2	24.4	17.1	26.0	17.0	27.6	16.7
	27.5	20.5	15.7	21.0	16.1	22.6	16.1	23.3	17.1	24.1	17.0	25.7	16.9	27.4	16.7
	30.0	20.3	15.6	20.8	16.0	22.3	16.0	23.1	17.0	23.9	16.9	25.5	16.8	27.2	16.6
	32.5	20.1	15.5	20.5	15.9	22.1	15.9	22.8	16.9	23.6	16.8	25.2	16.7	26.9	16.5
	35.0	19.9	15.4	20.3	15.8	21.8	15.7	22.4	16.7	23.4	16.7	25.0	16.6	26.7	16.4
	37.5	19.7	15.3	20.0	15.7	21.5	15.6	22.3	16.7	23.1	16.6	24.7	16.5	26.4	16.3
	40.0	19.5	15.2	19.8	15.5	21.3	15.5	22.1	16.6	22.8	16.5	24.5	16.4	26.2	16.2
43.0	19.2	15.1	19.5	15.4	21.0	15.4	21.8	16.4	22.6	16.4	24.2	16.3	25.9	16.1	
250 (28.0)	20.0	26.5	19.9	27.3	20.5	29.2	20.4	30.1	21.7	31.1	21.6	33.1	21.3	35.2	21.0
	22.5	26.2	19.8	26.9	20.4	28.8	20.3	29.8	21.5	30.8	21.4	32.8	21.2	34.9	20.9
	25.0	25.9	19.7	26.6	20.2	28.5	20.1	29.5	21.4	30.5	21.3	32.4	21.1	34.6	20.8
	27.5	25.7	19.5	26.3	20.1	28.2	20.0	29.2	21.2	30.1	21.2	32.1	21.0	34.3	20.7
	30.0	25.4	19.4	26.0	19.9	27.9	19.8	28.9	21.1	29.8	21.0	31.8	20.8	33.9	20.6
	32.5	25.1	19.3	25.7	19.8	27.6	19.7	28.5	21.0	29.5	20.9	31.5	20.7	33.6	20.5
	35.0	24.9	19.2	25.4	19.6	27.2	19.6	28.0	20.7	29.2	20.8	31.2	20.6	33.3	20.4
	37.5	24.6	19.0	25.0	19.5	26.9	19.4	27.9	20.7	28.9	20.6	30.9	20.5	33.0	20.3
	40.0	24.3	18.9	24.7	19.3	26.6	19.3	27.6	20.6	28.6	20.5	30.6	20.4	32.7	20.2
43.0	24.0	18.7	24.3	19.1	26.2	19.1	27.2	20.4	28.2	20.4	30.2	20.2	32.4	20.0	

kcal/h=kW x 860 , BTU/h = kW x 3,412

1. Cooling [Ceiling concealed (Silent/Slim/High static pressure type)]

PEFY-P-VMR-E-L/R

CA:Capacity(kW) , SHC:Sensible Heat Capacity(kW)

Model size (Rated kW)	Outdoor air temp. °C D.B.	Indoor air temp.													
		21.5°C D.B. 15°C W.B.		23°C D.B. 16°C W.B.		25°C D.B. 18°C W.B.		27°C D.B. 19°C W.B.		28°C D.B. 20°C W.B.		30°C D.B. 22°C W.B.		32°C D.B. 24°C W.B.	
		CA	SHC	CA	SHC	CA	SHC	CA	SHC	CA	SHC	CA	SHC	CA	SHC
20 (2.2)	20.0	2.1	1.7	2.1	1.8	2.3	1.8	2.4	1.9	2.4	1.9	2.6	1.8	2.8	1.8
	22.5	2.1	1.7	2.1	1.8	2.3	1.7	2.3	1.9	2.4	1.9	2.6	1.8	2.7	1.8
	25.0	2.0	1.7	2.1	1.7	2.2	1.7	2.3	1.9	2.4	1.8	2.5	1.8	2.7	1.8
	27.5	2.0	1.7	2.1	1.7	2.2	1.7	2.3	1.8	2.4	1.8	2.5	1.8	2.7	1.8
	30.0	2.0	1.7	2.0	1.7	2.2	1.7	2.3	1.8	2.3	1.8	2.5	1.8	2.7	1.8
	32.5	2.0	1.7	2.0	1.7	2.2	1.7	2.2	1.8	2.3	1.8	2.5	1.8	2.6	1.8
	35.0	2.0	1.7	2.0	1.7	2.1	1.7	2.2	1.8	2.3	1.8	2.5	1.8	2.6	1.8
	37.5	1.9	1.6	2.0	1.7	2.1	1.7	2.2	1.8	2.3	1.8	2.4	1.8	2.6	1.8
	40.0	1.9	1.6	1.9	1.7	2.1	1.7	2.2	1.8	2.2	1.8	2.4	1.8	2.6	1.8
43.0	1.9	1.6	1.9	1.7	2.1	1.7	2.1	1.8	2.2	1.8	2.4	1.8	2.5	1.8	
25 (2.8)	20.0	2.6	2.0	2.7	2.0	2.9	2.0	3.0	2.1	3.1	2.1	3.3	2.1	3.5	2.1
	22.5	2.6	2.0	2.7	2.0	2.9	2.0	3.0	2.1	3.1	2.1	3.3	2.1	3.5	2.1
	25.0	2.6	2.0	2.7	2.0	2.9	2.0	2.9	2.1	3.0	2.1	3.2	2.1	3.5	2.1
	27.5	2.6	1.9	2.6	2.0	2.8	2.0	2.9	2.1	3.0	2.1	3.2	2.1	3.4	2.1
	30.0	2.5	1.9	2.6	2.0	2.8	2.0	2.9	2.1	3.0	2.1	3.2	2.1	3.4	2.0
	32.5	2.5	1.9	2.6	2.0	2.8	2.0	2.9	2.1	3.0	2.1	3.2	2.1	3.4	2.0
	35.0	2.5	1.9	2.5	1.9	2.7	1.9	2.8	2.1	2.9	2.1	3.1	2.0	3.3	2.0
	37.5	2.5	1.9	2.5	1.9	2.7	1.9	2.8	2.1	2.9	2.0	3.1	2.0	3.3	2.0
	40.0	2.4	1.9	2.5	1.9	2.7	1.9	2.8	2.0	2.9	2.0	3.1	2.0	3.3	2.0
43.0	2.4	1.9	2.4	1.9	2.6	1.9	2.7	2.0	2.8	2.0	3.0	2.0	3.2	2.0	
32 (3.6)	20.0	3.4	2.4	3.5	2.5	3.7	2.5	3.9	2.6	4.0	2.6	4.3	2.6	4.5	2.5
	22.5	3.4	2.4	3.5	2.5	3.7	2.5	3.8	2.6	4.0	2.6	4.2	2.6	4.5	2.5
	25.0	3.3	2.4	3.4	2.4	3.7	2.4	3.8	2.6	3.9	2.6	4.2	2.5	4.4	2.5
	27.5	3.3	2.4	3.4	2.4	3.6	2.4	3.8	2.6	3.9	2.5	4.1	2.5	4.4	2.5
	30.0	3.3	2.4	3.3	2.4	3.6	2.4	3.7	2.5	3.8	2.5	4.1	2.5	4.4	2.5
	32.5	3.2	2.3	3.3	2.4	3.5	2.4	3.7	2.5	3.8	2.5	4.1	2.5	4.3	2.5
	35.0	3.2	2.3	3.3	2.4	3.5	2.4	3.6	2.5	3.8	2.5	4.0	2.5	4.3	2.5
	37.5	3.2	2.3	3.2	2.3	3.5	2.3	3.6	2.5	3.7	2.5	4.0	2.5	4.2	2.4
	40.0	3.1	2.3	3.2	2.3	3.4	2.3	3.5	2.5	3.7	2.5	3.9	2.4	4.2	2.4
43.0	3.1	2.3	3.1	2.3	3.4	2.3	3.5	2.4	3.6	2.4	3.9	2.4	4.2	2.4	

kcal/h=kW x 860 , BTU/h = kW x 3,412

1. Cooling [Ceiling concealed (Silent/Slim/High static pressure type)]

PEFY-P-VMS1(L)-E

CA:Capacity(kW) . SHC:Sensible Heat Capacity(kW)

Model size (Rated kW)	Outdoor air temp. °C D.B.	Indoor air temp.													
		21.5°C D.B. 15°C W.B.		23°C D.B. 16°C W.B.		25°C D.B. 18°C W.B.		27°C D.B. 19°C W.B.		28°C D.B. 20°C W.B.		30°C D.B. 22°C W.B.		32°C D.B. 24°C W.B.	
		CA	SHC	CA	SHC	CA	SHC	CA	SHC	CA	SHC	CA	SHC	CA	SHC
15 (1.7)	20.0	1.6	1.5	1.7	1.5	1.8	1.5	1.8	1.6	1.9	1.6	2.0	1.6	2.1	1.6
	22.5	1.6	1.5	1.6	1.5	1.8	1.5	1.8	1.6	1.9	1.6	2.0	1.6	2.1	1.6
	25.0	1.6	1.5	1.6	1.5	1.7	1.5	1.8	1.6	1.8	1.6	2.0	1.6	2.1	1.6
	27.5	1.6	1.4	1.6	1.5	1.7	1.5	1.8	1.6	1.8	1.6	2.0	1.6	2.1	1.6
	30.0	1.5	1.4	1.6	1.5	1.7	1.5	1.8	1.6	1.8	1.6	1.9	1.6	2.1	1.6
	32.5	1.5	1.4	1.6	1.5	1.7	1.5	1.7	1.6	1.8	1.6	1.9	1.6	2.0	1.6
	35.0	1.5	1.4	1.5	1.5	1.7	1.5	1.7	1.6	1.8	1.6	1.9	1.6	2.0	1.6
	37.5	1.5	1.4	1.5	1.5	1.6	1.5	1.7	1.6	1.8	1.6	1.9	1.6	2.0	1.5
	40.0	1.5	1.4	1.5	1.5	1.6	1.5	1.7	1.6	1.7	1.6	1.9	1.6	2.0	1.5
43.0	1.5	1.4	1.5	1.4	1.6	1.4	1.7	1.6	1.7	1.6	1.8	1.5	2.0	1.5	
20 (2.2)	20.0	2.1	1.8	2.1	1.8	2.3	1.8	2.4	2.0	2.4	2.0	2.6	1.9	2.8	1.9
	22.5	2.1	1.8	2.1	1.8	2.3	1.8	2.3	2.0	2.4	1.9	2.6	1.9	2.7	1.9
	25.0	2.0	1.8	2.1	1.8	2.2	1.8	2.3	1.9	2.4	1.9	2.5	1.9	2.7	1.9
	27.5	2.0	1.7	2.1	1.8	2.2	1.8	2.3	1.9	2.4	1.9	2.5	1.9	2.7	1.9
	30.0	2.0	1.7	2.0	1.8	2.2	1.8	2.3	1.9	2.3	1.9	2.5	1.9	2.7	1.9
	32.5	2.0	1.7	2.0	1.8	2.2	1.8	2.2	1.9	2.3	1.9	2.5	1.9	2.6	1.9
	35.0	2.0	1.7	2.0	1.8	2.1	1.8	2.2	1.9	2.3	1.9	2.5	1.9	2.6	1.9
	37.5	1.9	1.7	2.0	1.8	2.1	1.8	2.2	1.9	2.3	1.9	2.4	1.9	2.6	1.9
	40.0	1.9	1.7	1.9	1.8	2.1	1.7	2.2	1.9	2.2	1.9	2.4	1.9	2.6	1.8
43.0	1.9	1.7	1.9	1.7	2.1	1.7	2.1	1.9	2.2	1.9	2.4	1.9	2.5	1.8	
25 (2.8)	20.0	2.6	2.1	2.7	2.2	2.9	2.2	3.0	2.3	3.1	2.3	3.3	2.3	3.5	2.3
	22.5	2.6	2.1	2.7	2.2	2.9	2.2	3.0	2.3	3.1	2.3	3.3	2.3	3.5	2.3
	25.0	2.6	2.1	2.7	2.2	2.9	2.2	2.9	2.3	3.0	2.3	3.2	2.3	3.5	2.2
	27.5	2.6	2.1	2.6	2.2	2.8	2.1	2.9	2.3	3.0	2.3	3.2	2.3	3.4	2.2
	30.0	2.5	2.1	2.6	2.1	2.8	2.1	2.9	2.3	3.0	2.3	3.2	2.3	3.4	2.2
	32.5	2.5	2.1	2.6	2.1	2.8	2.1	2.9	2.3	3.0	2.3	3.2	2.2	3.4	2.2
	35.0	2.5	2.1	2.5	2.1	2.7	2.1	2.8	2.2	2.9	2.2	3.1	2.2	3.3	2.2
	37.5	2.5	2.0	2.5	2.1	2.7	2.1	2.8	2.2	2.9	2.2	3.1	2.2	3.3	2.2
	40.0	2.4	2.0	2.5	2.1	2.7	2.1	2.8	2.2	2.9	2.2	3.1	2.2	3.3	2.2
43.0	2.4	2.0	2.4	2.1	2.6	2.1	2.7	2.2	2.8	2.2	3.0	2.2	3.2	2.2	
32 (3.6)	20.0	3.4	2.6	3.5	2.7	3.7	2.6	3.9	2.8	4.0	2.8	4.3	2.8	4.5	2.7
	22.5	3.4	2.6	3.5	2.6	3.7	2.6	3.8	2.8	4.0	2.8	4.2	2.7	4.5	2.7
	25.0	3.3	2.5	3.4	2.6	3.7	2.6	3.8	2.8	3.9	2.8	4.2	2.7	4.4	2.7
	27.5	3.3	2.5	3.4	2.6	3.6	2.6	3.8	2.7	3.9	2.7	4.1	2.7	4.4	2.7
	30.0	3.3	2.5	3.3	2.6	3.6	2.6	3.7	2.7	3.8	2.7	4.1	2.7	4.4	2.7
	32.5	3.2	2.5	3.3	2.6	3.5	2.5	3.7	2.7	3.8	2.7	4.1	2.7	4.3	2.7
	35.0	3.2	2.5	3.3	2.5	3.5	2.5	3.6	2.7	3.8	2.7	4.0	2.7	4.3	2.6
	37.5	3.2	2.5	3.2	2.5	3.5	2.5	3.6	2.7	3.7	2.7	4.0	2.7	4.2	2.6
	40.0	3.1	2.4	3.2	2.5	3.4	2.5	3.5	2.7	3.7	2.7	3.9	2.6	4.2	2.6
43.0	3.1	2.4	3.1	2.5	3.4	2.5	3.5	2.6	3.6	2.6	3.9	2.6	4.2	2.6	
40 (4.5)	20.0	4.3	3.1	4.4	3.2	4.7	3.2	4.8	3.4	5.0	3.4	5.3	3.3	5.7	3.3
	22.5	4.2	3.1	4.3	3.2	4.6	3.2	4.8	3.4	4.9	3.4	5.3	3.3	5.6	3.3
	25.0	4.2	3.1	4.3	3.2	4.6	3.2	4.7	3.4	4.9	3.3	5.2	3.3	5.6	3.3
	27.5	4.1	3.1	4.2	3.1	4.5	3.1	4.7	3.3	4.8	3.3	5.2	3.3	5.5	3.2
	30.0	4.1	3.1	4.2	3.1	4.5	3.1	4.6	3.3	4.8	3.3	5.1	3.3	5.5	3.2
	32.5	4.0	3.0	4.1	3.1	4.4	3.1	4.6	3.3	4.7	3.3	5.1	3.2	5.4	3.2
	35.0	4.0	3.0	4.1	3.1	4.4	3.1	4.5	3.2	4.7	3.3	5.0	3.2	5.4	3.2
	37.5	4.0	3.0	4.0	3.1	4.3	3.0	4.5	3.2	4.6	3.2	5.0	3.2	5.3	3.2
	40.0	3.9	3.0	4.0	3.0	4.3	3.0	4.4	3.2	4.6	3.2	4.9	3.2	5.3	3.2
43.0	3.9	2.9	3.9	3.0	4.2	3.0	4.4	3.2	4.5	3.2	4.9	3.2	5.2	3.1	
50 (5.6)	20.0	5.3	3.8	5.5	3.9	5.8	3.9	6.0	4.1	6.2	4.1	6.6	4.1	7.0	4.0
	22.5	5.2	3.8	5.4	3.9	5.8	3.9	6.0	4.1	6.2	4.1	6.6	4.1	7.0	4.0
	25.0	5.2	3.8	5.3	3.9	5.7	3.9	5.9	4.1	6.1	4.1	6.5	4.0	6.9	4.0
	27.5	5.1	3.8	5.3	3.9	5.6	3.8	5.8	4.1	6.0	4.0	6.4	4.0	6.9	4.0
	30.0	5.1	3.7	5.2	3.8	5.6	3.8	5.8	4.0	6.0	4.0	6.4	4.0	6.8	3.9
	32.5	5.0	3.7	5.1	3.8	5.5	3.8	5.7	4.0	5.9	4.0	6.3	4.0	6.7	3.9
	35.0	5.0	3.7	5.1	3.8	5.4	3.8	5.6	4.0	5.8	4.0	6.2	3.9	6.7	3.9
	37.5	4.9	3.7	5.0	3.7	5.4	3.7	5.6	4.0	5.8	3.9	6.2	3.9	6.6	3.9
	40.0	4.9	3.6	4.9	3.7	5.3	3.7	5.5	3.9	5.7	3.9	6.1	3.9	6.5	3.8
43.0	4.8	3.6	4.9	3.7	5.2	3.7	5.4	3.9	5.6	3.9	6.0	3.9	6.5	3.8	
63 (7.1)	20.0	6.7	4.9	6.9	5.0	7.4	5.0	7.6	5.2	7.9	5.2	8.4	5.2	8.9	5.1
	22.5	6.6	4.8	6.8	4.9	7.3	4.9	7.6	5.2	7.8	5.2	8.3	5.1	8.8	5.1
	25.0	6.6	4.8	6.8	4.9	7.2	4.9	7.5	5.2	7.7	5.1	8.2	5.1	8.8	5.0
	27.5	6.5	4.8	6.7	4.9	7.2	4.8	7.4	5.1	7.6	5.1	8.2	5.1	8.7	5.0
	30.0	6.4	4.7	6.6	4.8	7.1	4.8	7.3	5.1	7.6	5.1	8.1	5.0	8.6	5.0
	32.5	6.4	4.7	6.5	4.8	7.0	4.8	7.2	5.1	7.5	5.0	8.0	5.0	8.5	4.9
	35.0	6.3	4.7	6.4	4.7	6.9	4.7	7.1	5.0	7.4	5.0	7.9	5.0	8.5	4.9
	37.5	6.2	4.6	6.3	4.7	6.8	4.7	7.1	5.0	7.3	5.0	7.8	4.9	8.4	4.9
	40.0	6.2	4.6	6.3	4.7	6.7	4.7	7.0	5.0	7.2	4.9	7.8	4.9	8.3	4.9
43.0	6.1	4.5	6.2	4.6	6.7	4.6	6.9	4.9	7.1	4.9	7.7	4.9	8.2	4.8	

kcal/h=kW x 860 , BTU/h = kW x 3,412

2. Cooling [Ceiling concealed (Middle static pressure type)]

2-1. Cooling capacity with PUHY,PURY-RP200-250YJM

PEFY-P-VMA(L)-E

CA:Capacity(kW) , SHC:Sensible Heat Capacity(kW)

Model size (Rated kW)	Outdoor air temp. °C D.B.	Indoor air temp.													
		21.5°C D.B. 15°C W.B.		23°C D.B. 16°C W.B.		25°C D.B. 18°C W.B.		27°C D.B. 19°C W.B.		28°C D.B. 20°C W.B.		30°C D.B. 22°C W.B.		32°C D.B. 24°C W.B.	
		CA	SHC	CA	SHC	CA	SHC	CA	SHC	CA	SHC	CA	SHC	CA	SHC
20 (2.2)	20.0	2.1	1.9	2.2	1.9	2.3	1.9	2.4	2.1	2.5	2.0	2.6	2.0	2.8	2.0
	22.5	2.1	1.9	2.2	1.9	2.3	1.9	2.4	2.1	2.5	2.0	2.6	2.0	2.8	2.0
	25.0	2.1	1.9	2.2	1.9	2.3	1.9	2.4	2.1	2.4	2.0	2.6	2.0	2.7	2.0
	27.5	2.1	1.9	2.1	1.9	2.3	1.9	2.3	2.0	2.4	2.0	2.5	2.0	2.7	2.0
	30.0	2.0	1.8	2.1	1.9	2.2	1.9	2.3	2.0	2.3	2.0	2.5	2.0	2.6	2.0
	32.5	2.0	1.8	2.1	1.9	2.2	1.9	2.2	2.0	2.3	2.0	2.4	2.0	2.6	1.9
	35.0	2.0	1.8	2.0	1.9	2.1	1.8	2.2	2.0	2.3	2.0	2.4	1.9	2.5	1.9
	37.5	1.9	1.8	2.0	1.9	2.1	1.8	2.2	2.0	2.2	2.0	2.3	1.9	2.5	1.9
	40.0	1.9	1.8	2.0	1.8	2.1	1.8	2.1	2.0	2.2	1.9	2.3	1.9	2.4	1.9
43.0	1.8	1.7	1.9	1.8	2.0	1.8	2.1	1.9	2.1	1.9	2.2	1.9	2.3	1.9	
25 (2.8)	20.0	2.7	2.1	2.8	2.2	2.9	2.2	3.0	2.3	3.1	2.3	3.3	2.3	3.5	2.2
	22.5	2.7	2.1	2.8	2.2	2.9	2.2	3.0	2.3	3.1	2.3	3.3	2.3	3.5	2.2
	25.0	2.7	2.1	2.8	2.2	2.9	2.2	3.0	2.3	3.1	2.3	3.3	2.2	3.5	2.2
	27.5	2.7	2.1	2.7	2.2	2.9	2.1	3.0	2.3	3.0	2.2	3.2	2.2	3.4	2.2
	30.0	2.6	2.1	2.7	2.1	2.8	2.1	2.9	2.2	3.0	2.2	3.2	2.2	3.3	2.2
	32.5	2.6	2.0	2.6	2.1	2.8	2.1	2.9	2.2	2.9	2.2	3.1	2.2	3.3	2.1
	35.0	2.5	2.0	2.6	2.1	2.7	2.1	2.8	2.2	2.9	2.2	3.0	2.1	3.2	2.1
	37.5	2.5	2.0	2.5	2.1	2.7	2.0	2.8	2.2	2.8	2.2	3.0	2.1	3.1	2.1
	40.0	2.4	2.0	2.5	2.0	2.6	2.0	2.7	2.2	2.8	2.1	2.9	2.1	3.1	2.1
43.0	2.4	2.0	2.4	2.0	2.6	2.0	2.6	2.1	2.7	2.1	2.8	2.1	3.0	2.0	
32 (3.6)	20.0	3.4	2.5	3.5	2.6	3.8	2.6	3.9	2.8	4.0	2.7	4.3	2.7	4.6	2.7
	22.5	3.4	2.5	3.5	2.6	3.8	2.6	3.9	2.8	4.0	2.7	4.3	2.7	4.6	2.7
	25.0	3.4	2.5	3.5	2.6	3.8	2.6	3.9	2.8	4.0	2.7	4.2	2.7	4.5	2.7
	27.5	3.4	2.5	3.5	2.6	3.7	2.6	3.8	2.7	3.9	2.7	4.1	2.7	4.4	2.6
	30.0	3.3	2.5	3.4	2.6	3.6	2.6	3.7	2.7	3.8	2.7	4.1	2.6	4.3	2.6
	32.5	3.3	2.5	3.4	2.6	3.6	2.5	3.7	2.7	3.8	2.6	4.0	2.6	4.2	2.6
	35.0	3.2	2.5	3.3	2.5	3.5	2.5	3.6	2.6	3.7	2.6	3.9	2.6	4.1	2.5
	37.5	3.2	2.4	3.3	2.5	3.4	2.5	3.5	2.6	3.6	2.6	3.8	2.5	4.0	2.5
	40.0	3.1	2.4	3.2	2.5	3.4	2.4	3.5	2.6	3.6	2.6	3.7	2.5	3.9	2.5
43.0	3.0	2.4	3.1	2.4	3.3	2.4	3.4	2.5	3.5	2.5	3.6	2.5	3.8	2.4	
40 (4.5)	20.0	4.3	3.4	4.4	3.6	4.7	3.5	4.9	3.8	5.0	3.7	5.3	3.7	5.7	3.7
	22.5	4.3	3.4	4.4	3.6	4.7	3.5	4.9	3.8	5.0	3.7	5.3	3.7	5.7	3.7
	25.0	4.3	3.4	4.4	3.6	4.7	3.5	4.9	3.8	5.0	3.7	5.3	3.7	5.6	3.6
	27.5	4.3	3.4	4.4	3.5	4.6	3.5	4.8	3.7	4.9	3.7	5.2	3.6	5.5	3.6
	30.0	4.2	3.4	4.3	3.5	4.6	3.5	4.7	3.7	4.8	3.7	5.1	3.6	5.4	3.5
	32.5	4.1	3.3	4.2	3.5	4.5	3.4	4.6	3.6	4.7	3.6	5.0	3.6	5.3	3.5
	35.0	4.0	3.3	4.1	3.4	4.4	3.4	4.5	3.6	4.6	3.6	4.9	3.5	5.2	3.5
	37.5	4.0	3.3	4.1	3.4	4.3	3.3	4.4	3.6	4.5	3.5	4.8	3.5	5.0	3.4
	40.0	3.9	3.2	4.0	3.4	4.2	3.3	4.3	3.5	4.4	3.5	4.7	3.4	4.9	3.4
43.0	3.8	3.2	3.9	3.3	4.1	3.3	4.2	3.5	4.3	3.5	4.5	3.4	4.8	3.4	
50 (5.6)	20.0	5.3	4.2	5.5	4.4	5.9	4.3	6.1	4.6	6.2	4.6	6.6	4.5	7.1	4.5
	22.5	5.3	4.2	5.5	4.4	5.9	4.3	6.1	4.6	6.2	4.6	6.6	4.5	7.1	4.5
	25.0	5.3	4.2	5.5	4.4	5.9	4.3	6.0	4.6	6.2	4.6	6.6	4.5	7.0	4.5
	27.5	5.3	4.2	5.5	4.3	5.8	4.3	5.9	4.6	6.1	4.5	6.4	4.5	6.8	4.4
	30.0	5.2	4.2	5.4	4.3	5.7	4.3	5.8	4.5	6.0	4.5	6.3	4.4	6.7	4.4
	32.5	5.1	4.1	5.3	4.3	5.6	4.2	5.7	4.5	5.9	4.4	6.2	4.4	6.6	4.3
	35.0	5.0	4.1	5.2	4.2	5.5	4.2	5.6	4.4	5.8	4.4	6.1	4.3	6.4	4.3
	37.5	4.9	4.0	5.1	4.2	5.4	4.1	5.5	4.4	5.6	4.4	5.9	4.3	6.3	4.2
	40.0	4.8	4.0	5.0	4.1	5.3	4.1	5.4	4.3	5.5	4.3	5.8	4.2	6.1	4.2
43.0	4.7	3.9	4.8	4.1	5.1	4.0	5.3	4.3	5.4	4.3	5.6	4.2	6.0	4.1	
63 (7.1)	20.0	6.7	5.2	7.0	5.4	7.5	5.4	7.7	5.7	7.9	5.7	8.4	5.6	9.0	5.5
	22.5	6.7	5.2	7.0	5.4	7.5	5.4	7.7	5.7	7.9	5.7	8.4	5.6	9.0	5.5
	25.0	6.7	5.2	7.0	5.4	7.5	5.4	7.7	5.7	7.9	5.6	8.3	5.6	8.8	5.5
	27.5	6.7	5.2	6.9	5.4	7.3	5.3	7.5	5.6	7.7	5.6	8.1	5.5	8.7	5.4
	30.0	6.6	5.2	6.8	5.3	7.2	5.3	7.4	5.6	7.6	5.5	8.0	5.4	8.5	5.4
	32.5	6.5	5.1	6.7	5.3	7.1	5.2	7.2	5.5	7.4	5.5	7.8	5.4	8.3	5.3
	35.0	6.4	5.0	6.5	5.2	6.9	5.1	7.1	5.5	7.3	5.4	7.7	5.3	8.1	5.2
	37.5	6.2	5.0	6.4	5.1	6.8	5.1	7.0	5.4	7.2	5.4	7.5	5.3	8.0	5.2
	40.0	6.1	4.9	6.3	5.1	6.7	5.0	6.8	5.3	7.0	5.3	7.4	5.2	7.8	5.1
43.0	6.0	4.9	6.1	5.0	6.5	5.0	6.7	5.3	6.9	5.2	7.2	5.1	7.6	5.1	
71 (8.0)	20.0	7.6	5.7	7.9	5.9	8.4	5.8	8.7	6.2	8.9	6.1	9.5	6.1	10.1	6.0
	22.5	7.6	5.7	7.9	5.9	8.4	5.8	8.7	6.2	8.9	6.1	9.5	6.1	10.1	6.0
	25.0	7.6	5.7	7.9	5.9	8.4	5.8	8.6	6.2	8.9	6.1	9.4	6.0	10.0	5.9
	27.5	7.6	5.7	7.8	5.8	8.3	5.8	8.5	6.1	8.7	6.0	9.2	6.0	9.8	5.9
	30.0	7.4	5.6	7.7	5.8	8.1	5.7	8.3	6.0	8.5	6.0	9.0	5.9	9.6	5.8
	32.5	7.3	5.5	7.5	5.7	8.0	5.6	8.2	6.0	8.4	5.9	8.8	5.8	9.4	5.7
	35.0	7.2	5.5	7.4	5.6	7.8	5.6	8.0	5.9	8.2	5.9	8.6	5.7	9.2	5.7
	37.5	7.0	5.4	7.2	5.6	7.7	5.5	7.9	5.8	8.1	5.8	8.5	5.7	9.0	5.6
	40.0	6.9	5.3	7.1	5.5	7.5	5.4	7.7	5.8	7.9	5.7	8.3	5.6	8.8	5.5
43.0	6.7	5.3	6.9	5.4	7.3	5.4	7.5	5.7	7.7	5.7	8.1	5.5	8.5	5.4	

kcal/h=kW x 860 , BTU/h = kW x 3,412

2. Cooling [Ceiling concealed (Middle static pressure type)]

PEFY-P-VMA(L)-E

CA:Capacity(kW) , SHC:Sensible Heat Capacity(kW)

Model size (Rated kW)	Outdoor air temp. °C D.B.	Indoor air temp.													
		21.5°C D.B. 15°C W.B.		23°C D.B. 16°C W.B.		25°C D.B. 18°C W.B.		27°C D.B. 19°C W.B.		28°C D.B. 20°C W.B.		30°C D.B. 22°C W.B.		32°C D.B. 24°C W.B.	
		CA	SHC	CA	SHC	CA	SHC	CA	SHC	CA	SHC	CA	SHC	CA	SHC
80 (9.0)	20.0	8.6	6.1	8.9	6.3	9.5	6.3	9.7	6.6	10.0	6.6	10.6	6.5	11.4	6.4
	22.5	8.6	6.1	8.9	6.3	9.5	6.3	9.7	6.6	10.0	6.6	10.6	6.5	11.4	6.4
	25.0	8.6	6.1	8.9	6.3	9.5	6.3	9.7	6.6	10.0	6.5	10.5	6.4	11.2	6.4
	27.5	8.5	6.1	8.8	6.3	9.3	6.2	9.5	6.5	9.8	6.5	10.3	6.4	11.0	6.3
	30.0	8.4	6.0	8.6	6.2	9.1	6.1	9.4	6.4	9.6	6.4	10.1	6.3	10.8	6.2
	32.5	8.2	6.0	8.5	6.1	8.9	6.0	9.2	6.4	9.4	6.3	9.9	6.2	10.5	6.1
	35.0	8.1	5.9	8.3	6.0	8.8	6.0	9.0	6.3	9.2	6.2	9.7	6.1	10.3	6.0
	37.5	7.9	5.8	8.1	6.0	8.6	5.9	8.8	6.2	9.1	6.2	9.5	6.0	10.1	5.9
	40.0	7.7	5.7	8.0	5.9	8.4	5.8	8.7	6.1	8.9	6.1	9.3	6.0	9.9	5.9
43.0	7.6	5.6	7.8	5.8	8.2	5.7	8.5	6.0	8.7	6.0	9.1	5.9	9.6	5.8	
100 (11.2)	20.0	10.6	8.4	11.0	8.7	11.8	8.6	12.1	9.2	12.5	9.1	13.2	9.0	14.2	8.9
	22.5	10.6	8.4	11.0	8.7	11.8	8.6	12.1	9.2	12.5	9.1	13.2	9.0	14.2	8.9
	25.0	10.6	8.4	11.0	8.7	11.8	8.6	12.1	9.2	12.4	9.1	13.1	9.0	13.9	8.9
	27.5	10.6	8.4	10.9	8.6	11.6	8.6	11.9	9.1	12.2	9.0	12.9	8.9	13.7	8.8
	30.0	10.4	8.3	10.7	8.6	11.3	8.5	11.6	9.0	12.0	8.9	12.6	8.8	13.4	8.7
	32.5	10.2	8.2	10.5	8.5	11.1	8.4	11.4	8.9	11.7	8.8	12.4	8.7	13.1	8.6
	35.0	10.0	8.1	10.3	8.4	10.9	8.3	11.2	8.8	11.5	8.8	12.1	8.6	12.8	8.5
	37.5	9.8	8.0	10.1	8.3	10.7	8.2	11.0	8.7	11.3	8.7	11.9	8.5	12.6	8.4
	40.0	9.6	7.9	9.9	8.2	10.5	8.1	10.8	8.6	11.1	8.6	11.6	8.4	12.3	8.3
43.0	9.4	7.8	9.7	8.1	10.2	8.0	10.5	8.5	10.8	8.5	11.3	8.3	12.0	8.2	
125 (14.0)	20.0	13.3	10.2	13.8	10.6	14.7	10.5	15.2	11.2	15.6	11.1	16.6	11.0	17.7	10.8
	22.5	13.3	10.2	13.8	10.6	14.7	10.5	15.2	11.2	15.6	11.1	16.6	11.0	17.7	10.8
	25.0	13.3	10.2	13.8	10.6	14.7	10.5	15.1	11.1	15.5	11.0	16.4	10.9	17.4	10.7
	27.5	13.3	10.2	13.6	10.5	14.4	10.4	14.8	11.0	15.2	10.9	16.1	10.8	17.1	10.6
	30.0	13.0	10.1	13.4	10.4	14.2	10.3	14.6	10.9	14.9	10.8	15.8	10.6	16.7	10.5
	32.5	12.8	10.0	13.2	10.3	13.9	10.2	14.3	10.8	14.7	10.7	15.4	10.5	16.4	10.4
	35.0	12.5	9.9	12.9	10.2	13.7	10.1	14.0	10.7	14.4	10.6	15.1	10.4	16.0	10.3
	37.5	12.3	9.8	12.7	10.1	13.4	9.9	13.8	10.6	14.1	10.5	14.8	10.3	15.7	10.1
	40.0	12.1	9.6	12.4	9.9	13.1	9.8	13.5	10.5	13.8	10.4	14.5	10.2	15.4	10.0
43.0	11.8	9.5	12.1	9.8	12.8	9.7	13.2	10.3	13.5	10.3	14.1	10.0	15.0	9.9	
140 (16.0)	20.0	15.2	11.6	15.8	12.0	16.8	11.9	17.3	12.6	17.8	12.5	18.9	12.4	20.2	12.2
	22.5	15.2	11.6	15.8	12.0	16.8	11.9	17.3	12.6	17.8	12.5	18.9	12.4	20.2	12.2
	25.0	15.2	11.6	15.8	12.0	16.8	11.9	17.3	12.6	17.7	12.5	18.7	12.3	19.9	12.1
	27.5	15.2	11.5	15.6	11.9	16.5	11.7	16.9	12.4	17.4	12.3	18.4	12.1	19.5	12.0
	30.0	14.9	11.4	15.3	11.8	16.2	11.6	16.6	12.3	17.1	12.2	18.0	12.0	19.1	11.8
	32.5	14.6	11.3	15.0	11.6	15.9	11.5	16.3	12.2	16.8	12.1	17.6	11.9	18.7	11.7
	35.0	14.3	11.1	14.8	11.5	15.6	11.4	16.0	12.0	16.4	12.0	17.3	11.7	18.3	11.6
	37.5	14.1	11.0	14.5	11.4	15.3	11.2	15.7	11.9	16.1	11.8	16.9	11.6	17.9	11.4
	40.0	13.8	10.9	14.2	11.2	15.0	11.1	15.4	11.8	15.8	11.7	16.6	11.5	17.6	11.3
43.0	13.4	10.7	13.8	11.1	14.6	10.9	15.0	11.6	15.4	11.6	16.1	11.3	17.1	11.1	

kcal/h=kW x 860 , BTU/h = kW x 3,412

2. Cooling [Ceiling concealed (Middle static pressure type)]

2-2. Cooling capacity with PUHY-RP300-400Y(S)JM,PURY-RP300YJM

PEFY-P-VMA(L)-E

CA:Capacity(kW) , SHC:Sensible Heat Capacity(kW)

Model size (Rated kW)	Outdoor air temp.	Indoor air temp.													
		21.5°C D.B. 15°C W.B.		23°C D.B. 16°C W.B.		25°C D.B. 18°C W.B.		27°C D.B. 19°C W.B.		28°C D.B. 20°C W.B.		30°C D.B. 22°C W.B.		32°C D.B. 24°C W.B.	
		°C D.B.	CA	SHC	CA	SHC	CA	SHC	CA	SHC	CA	SHC	CA	SHC	CA
20 (2.2)	20.0	2.1	1.9	2.2	2.0	2.4	1.9	2.5	2.1	2.5	2.1	2.7	2.1	2.9	2.0
	22.5	2.1	1.9	2.2	1.9	2.3	1.9	2.4	2.1	2.5	2.1	2.6	2.0	2.8	2.0
	25.0	2.1	1.9	2.2	1.9	2.3	1.9	2.4	2.1	2.4	2.0	2.6	2.0	2.8	2.0
	27.5	2.1	1.8	2.1	1.9	2.3	1.9	2.3	2.0	2.4	2.0	2.5	2.0	2.7	2.0
	30.0	2.0	1.8	2.1	1.9	2.2	1.9	2.3	2.0	2.4	2.0	2.5	2.0	2.6	2.0
	32.5	2.0	1.8	2.0	1.9	2.2	1.9	2.2	2.0	2.3	2.0	2.4	2.0	2.6	1.9
	35.0	2.0	1.8	2.0	1.9	2.1	1.8	2.2	2.0	2.3	2.0	2.4	2.0	2.5	1.9
	37.5	1.9	1.8	2.0	1.8	2.1	1.8	2.1	2.0	2.2	2.0	2.3	1.9	2.5	1.9
	40.0	1.9	1.8	1.9	1.8	2.0	1.8	2.1	1.9	2.2	1.9	2.3	1.9	2.4	1.9
43.0	1.9	1.7	1.9	1.8	2.0	1.8	2.0	1.9	2.1	1.9	2.2	1.9	2.4	1.9	
25 (2.8)	20.0	2.7	2.1	2.8	2.2	3.0	2.2	3.1	2.3	3.2	2.3	3.4	2.3	3.6	2.3
	22.5	2.7	2.1	2.8	2.2	3.0	2.2	3.1	2.3	3.2	2.3	3.4	2.3	3.6	2.2
	25.0	2.7	2.1	2.7	2.2	2.9	2.1	3.0	2.3	3.1	2.3	3.3	2.2	3.5	2.2
	27.5	2.6	2.1	2.7	2.1	2.9	2.1	3.0	2.3	3.1	2.3	3.2	2.2	3.4	2.2
	30.0	2.6	2.1	2.6	2.1	2.8	2.1	2.9	2.2	3.0	2.2	3.2	2.2	3.4	2.2
	32.5	2.5	2.0	2.6	2.1	2.8	2.1	2.8	2.2	2.9	2.2	3.1	2.2	3.3	2.1
	35.0	2.5	2.0	2.5	2.1	2.7	2.1	2.8	2.2	2.9	2.2	3.0	2.2	3.2	2.1
	37.5	2.5	2.0	2.5	2.0	2.6	2.0	2.7	2.2	2.8	2.2	3.0	2.1	3.2	2.1
	40.0	2.4	2.0	2.4	2.0	2.6	2.0	2.7	2.1	2.8	2.1	2.9	2.1	3.1	2.1
43.0	2.4	2.0	2.4	2.0	2.5	2.0	2.6	2.1	2.7	2.1	2.8	2.1	3.0	2.1	
32 (3.6)	20.0	3.5	2.6	3.6	2.7	3.9	2.7	4.0	2.8	4.2	2.8	4.4	2.8	4.7	2.7
	22.5	3.5	2.6	3.6	2.7	3.8	2.6	4.0	2.8	4.1	2.8	4.3	2.7	4.6	2.7
	25.0	3.4	2.6	3.5	2.6	3.8	2.6	3.9	2.8	4.0	2.7	4.2	2.7	4.5	2.7
	27.5	3.4	2.5	3.5	2.6	3.7	2.6	3.8	2.7	3.9	2.7	4.2	2.7	4.4	2.6
	30.0	3.3	2.5	3.4	2.6	3.6	2.5	3.7	2.7	3.8	2.7	4.1	2.6	4.3	2.6
	32.5	3.3	2.5	3.3	2.5	3.5	2.5	3.7	2.7	3.8	2.6	4.0	2.6	4.2	2.6
	35.0	3.2	2.4	3.3	2.5	3.5	2.5	3.6	2.6	3.7	2.6	3.9	2.6	4.2	2.5
	37.5	3.2	2.4	3.2	2.5	3.4	2.4	3.5	2.6	3.6	2.6	3.8	2.6	4.1	2.5
	40.0	3.1	2.4	3.1	2.4	3.3	2.4	3.4	2.6	3.5	2.6	3.8	2.5	4.0	2.5
43.0	3.0	2.4	3.0	2.4	3.2	2.4	3.3	2.5	3.4	2.5	3.7	2.5	3.9	2.4	
40 (4.5)	20.0	4.4	3.5	4.5	3.6	4.9	3.6	5.0	3.8	5.2	3.8	5.5	3.8	5.8	3.7
	22.5	4.4	3.5	4.5	3.6	4.8	3.6	4.9	3.8	5.1	3.8	5.4	3.7	5.7	3.7
	25.0	4.3	3.4	4.4	3.5	4.7	3.5	4.9	3.8	5.0	3.7	5.3	3.7	5.6	3.6
	27.5	4.2	3.4	4.3	3.5	4.6	3.5	4.8	3.7	4.9	3.7	5.2	3.6	5.5	3.6
	30.0	4.1	3.4	4.2	3.5	4.5	3.4	4.7	3.7	4.8	3.7	5.1	3.6	5.4	3.6
	32.5	4.1	3.3	4.2	3.4	4.4	3.4	4.6	3.6	4.7	3.6	5.0	3.6	5.3	3.5
	35.0	4.0	3.3	4.1	3.4	4.3	3.4	4.5	3.6	4.6	3.6	4.9	3.5	5.2	3.5
	37.5	3.9	3.3	4.0	3.4	4.2	3.3	4.4	3.6	4.5	3.5	4.8	3.5	5.1	3.4
	40.0	3.9	3.2	3.9	3.3	4.2	3.3	4.3	3.5	4.4	3.5	4.7	3.5	5.0	3.4
43.0	3.8	3.2	3.8	3.3	4.0	3.2	4.2	3.5	4.3	3.5	4.6	3.4	4.8	3.4	
50 (5.6)	20.0	5.4	4.3	5.6	4.4	6.1	4.4	6.3	4.7	6.5	4.7	6.9	4.6	7.3	4.6
	22.5	5.4	4.3	5.6	4.4	6.0	4.4	6.2	4.7	6.3	4.6	6.7	4.6	7.1	4.5
	25.0	5.3	4.2	5.5	4.4	5.8	4.3	6.0	4.6	6.2	4.6	6.6	4.5	7.0	4.5
	27.5	5.3	4.2	5.4	4.3	5.7	4.3	5.9	4.6	6.1	4.5	6.5	4.5	6.9	4.4
	30.0	5.2	4.1	5.3	4.3	5.6	4.2	5.8	4.5	6.0	4.5	6.4	4.4	6.7	4.4
	32.5	5.1	4.1	5.2	4.2	5.5	4.2	5.7	4.5	5.9	4.4	6.2	4.4	6.6	4.3
	35.0	5.0	4.1	5.1	4.2	5.4	4.1	5.6	4.4	5.7	4.4	6.1	4.3	6.5	4.3
	37.5	4.9	4.0	5.0	4.1	5.3	4.1	5.5	4.4	5.6	4.4	6.0	4.3	6.3	4.2
	40.0	4.8	4.0	4.9	4.1	5.2	4.0	5.3	4.3	5.5	4.3	5.8	4.3	6.2	4.2
43.0	4.7	3.9	4.7	4.0	5.0	4.0	5.2	4.3	5.4	4.2	5.7	4.2	6.0	4.1	
63 (7.1)	20.0	6.9	5.3	7.1	5.5	7.7	5.5	7.9	5.8	8.2	5.8	8.7	5.7	9.2	5.6
	22.5	6.9	5.3	7.1	5.4	7.6	5.4	7.8	5.8	8.0	5.7	8.5	5.7	9.1	5.6
	25.0	6.8	5.2	7.0	5.4	7.4	5.3	7.7	5.7	7.9	5.7	8.4	5.6	8.9	5.5
	27.5	6.7	5.2	6.8	5.3	7.3	5.3	7.5	5.6	7.7	5.6	8.2	5.5	8.7	5.4
	30.0	6.5	5.1	6.7	5.3	7.1	5.2	7.4	5.6	7.6	5.5	8.1	5.5	8.5	5.4
	32.5	6.4	5.1	6.6	5.2	7.0	5.2	7.2	5.5	7.4	5.5	7.9	5.4	8.4	5.3
	35.0	6.3	5.0	6.4	5.1	6.8	5.1	7.1	5.5	7.3	5.4	7.7	5.3	8.2	5.3
	37.5	6.2	5.0	6.3	5.1	6.7	5.0	6.9	5.4	7.1	5.4	7.6	5.3	8.0	5.2
	40.0	6.1	4.9	6.2	5.0	6.6	5.0	6.8	5.3	7.0	5.3	7.4	5.2	7.8	5.1
43.0	6.0	4.9	6.0	4.9	6.4	4.9	6.6	5.2	6.8	5.2	7.2	5.2	7.6	5.1	
71 (8.0)	20.0	7.8	5.8	8.0	6.0	8.6	5.9	8.9	6.3	9.2	6.3	9.8	6.2	10.4	6.1
	22.5	7.7	5.8	8.0	5.9	8.5	5.9	8.8	6.2	9.1	6.2	9.6	6.1	10.2	6.0
	25.0	7.6	5.7	7.8	5.9	8.4	5.8	8.6	6.2	8.9	6.1	9.4	6.1	10.0	6.0
	27.5	7.5	5.6	7.7	5.8	8.2	5.7	8.5	6.1	8.7	6.1	9.3	6.0	9.8	5.9
	30.0	7.4	5.6	7.5	5.7	8.0	5.7	8.3	6.0	8.6	6.0	9.1	5.9	9.6	5.8
	32.5	7.3	5.5	7.4	5.6	7.9	5.6	8.1	5.9	8.4	5.9	8.9	5.8	9.4	5.8
	35.0	7.1	5.5	7.2	5.6	7.7	5.5	8.0	5.9	8.2	5.8	8.7	5.8	9.2	5.7
	37.5	7.0	5.4	7.1	5.5	7.5	5.5	7.8	5.8	8.0	5.8	8.5	5.7	9.0	5.6
	40.0	6.9	5.3	6.9	5.4	7.4	5.4	7.6	5.7	7.9	5.7	8.3	5.6	8.8	5.6
43.0	6.7	5.3	6.8	5.4	7.2	5.3	7.4	5.7	7.7	5.6	8.1	5.6	8.6	5.5	

kcal/h=kW x 860 , BTU/h = kW x 3,412

2. Cooling [Ceiling concealed (Middle static pressure type)]

PEFY-P-VMA(L)-E

CA:Capacity(kW) , SHC:Sensible Heat Capacity(kW)

Model size (Rated kW)	Outdoor air temp. °C D.B.	Indoor air temp.													
		21.5°C D.B. 15°C W.B.		23°C D.B. 16°C W.B.		25°C D.B. 18°C W.B.		27°C D.B. 19°C W.B.		28°C D.B. 20°C W.B.		30°C D.B. 22°C W.B.		32°C D.B. 24°C W.B.	
		CA	SHC	CA	SHC	CA	SHC	CA	SHC	CA	SHC	CA	SHC	CA	SHC
80 (9.0)	20.0	8.7	6.2	9.0	6.4	9.7	6.4	10.1	6.8	10.4	6.7	11.0	6.6	11.7	6.5
	22.5	8.7	6.2	9.0	6.4	9.6	6.3	9.9	6.7	10.2	6.6	10.8	6.6	11.5	6.5
	25.0	8.6	6.1	8.8	6.3	9.4	6.3	9.7	6.6	10.0	6.6	10.6	6.5	11.3	6.4
	27.5	8.4	6.1	8.6	6.2	9.2	6.2	9.5	6.5	9.8	6.5	10.4	6.4	11.0	6.3
	30.0	8.3	6.0	8.5	6.1	9.0	6.1	9.3	6.4	9.6	6.4	10.2	6.3	10.8	6.2
	32.5	8.2	5.9	8.3	6.0	8.9	6.0	9.1	6.3	9.4	6.3	10.0	6.2	10.6	6.1
	35.0	8.0	5.9	8.1	6.0	8.7	5.9	9.0	6.3	9.2	6.2	9.8	6.1	10.4	6.1
	37.5	7.9	5.8	8.0	5.9	8.5	5.8	8.8	6.2	9.0	6.1	9.6	6.1	10.2	6.0
	40.0	7.7	5.7	7.8	5.8	8.3	5.8	8.6	6.1	8.8	6.1	9.4	6.0	9.9	5.9
43.0	7.6	5.6	7.6	5.7	8.1	5.7	8.4	6.0	8.6	6.0	9.1	5.9	9.7	5.8	
100 (11.2)	20.0	10.9	8.5	11.3	8.8	12.1	8.8	12.5	9.4	12.9	9.3	13.7	9.2	14.5	9.1
	22.5	10.8	8.5	11.2	8.8	11.9	8.7	12.3	9.3	12.7	9.2	13.5	9.1	14.3	9.0
	25.0	10.7	8.4	11.0	8.7	11.7	8.6	12.1	9.2	12.5	9.1	13.2	9.0	14.0	8.9
	27.5	10.5	8.3	10.8	8.6	11.5	8.5	11.8	9.1	12.2	9.0	13.0	8.9	13.7	8.8
	30.0	10.3	8.3	10.6	8.5	11.2	8.4	11.6	9.0	12.0	8.9	12.7	8.8	13.5	8.7
	32.5	10.2	8.2	10.3	8.4	11.0	8.3	11.4	8.9	11.7	8.8	12.4	8.7	13.2	8.6
	35.0	10.0	8.1	10.1	8.3	10.8	8.2	11.2	8.8	11.5	8.7	12.2	8.6	12.9	8.5
	37.5	9.8	8.0	9.9	8.2	10.6	8.1	10.9	8.7	11.2	8.7	11.9	8.5	12.6	8.4
	40.0	9.6	7.9	9.7	8.1	10.3	8.0	10.7	8.6	11.0	8.6	11.7	8.5	12.4	8.3
43.0	9.4	7.8	9.5	8.0	10.1	7.9	10.4	8.5	10.7	8.4	11.4	8.3	12.1	8.2	
125 (14.0)	20.0	13.6	10.4	14.1	10.7	15.1	10.7	15.7	11.4	16.2	11.3	17.2	11.2	18.2	11.0
	22.5	13.6	10.4	14.0	10.7	14.9	10.6	15.4	11.3	15.9	11.2	16.8	11.1	17.8	10.9
	25.0	13.3	10.3	13.7	10.6	14.6	10.5	15.1	11.1	15.6	11.1	16.5	10.9	17.5	10.8
	27.5	13.1	10.2	13.5	10.4	14.3	10.4	14.8	11.0	15.3	11.0	16.2	10.8	17.2	10.7
	30.0	12.9	10.0	13.2	10.3	14.1	10.2	14.5	10.9	15.0	10.8	15.9	10.7	16.8	10.5
	32.5	12.7	9.9	12.9	10.2	13.8	10.1	14.2	10.8	14.7	10.7	15.6	10.6	16.5	10.4
	35.0	12.5	9.8	12.7	10.1	13.5	10.0	14.0	10.7	14.4	10.6	15.2	10.5	16.2	10.3
	37.5	12.3	9.7	12.4	9.9	13.2	9.9	13.6	10.5	14.1	10.5	14.9	10.3	15.8	10.2
	40.0	12.0	9.6	12.2	9.8	12.9	9.7	13.3	10.4	13.8	10.4	14.6	10.2	15.5	10.1
43.0	11.8	9.5	11.8	9.7	12.6	9.6	13.0	10.3	13.4	10.2	14.2	10.1	15.1	9.9	
140 (16.0)	20.0	15.5	11.7	16.1	12.1	17.3	12.1	17.9	12.8	18.5	12.8	19.6	12.6	20.8	12.4
	22.5	15.5	11.7	16.0	12.1	17.0	12.0	17.6	12.7	18.1	12.7	19.2	12.5	20.4	12.3
	25.0	15.3	11.6	15.7	11.9	16.7	11.8	17.3	12.6	17.8	12.5	18.9	12.3	20.0	12.2
	27.5	15.0	11.5	15.4	11.8	16.4	11.7	16.9	12.4	17.4	12.4	18.5	12.2	19.6	12.0
	30.0	14.8	11.4	15.1	11.6	16.1	11.6	16.6	12.3	17.1	12.2	18.1	12.1	19.2	11.9
	32.5	14.5	11.2	14.8	11.5	15.7	11.4	16.3	12.1	16.8	12.1	17.8	11.9	18.8	11.8
	35.0	14.3	11.1	14.5	11.4	15.4	11.3	16.0	12.0	16.4	11.9	17.4	11.8	18.5	11.6
	37.5	14.0	11.0	14.2	11.2	15.1	11.1	15.6	11.9	16.1	11.8	17.0	11.7	18.1	11.5
	40.0	13.8	10.9	13.9	11.1	14.8	11.0	15.2	11.7	15.7	11.7	16.7	11.5	17.7	11.3
43.0	13.5	10.7	13.5	10.9	14.4	10.8	14.8	11.6	15.3	11.5	16.3	11.4	17.2	11.2	

kcal/h=kW x 860 , BTU/h = kW x 3,412

2. Cooling [Ceiling concealed (Middle static pressure type)]

2-3. Cooling capacity with PUHY-RP450-650YSJM

PEFY-P-VMA(L)-E

CA:Capacity(kW) , SHC:Sensible Heat Capacity(kW)

Model size (Rated kW)	Outdoor air temp.	Indoor air temp.													
		21.5°C D.B. 15°C W.B.		23°C D.B. 16°C W.B.		25°C D.B. 18°C W.B.		27°C D.B. 19°C W.B.		28°C D.B. 20°C W.B.		30°C D.B. 22°C W.B.		32°C D.B. 24°C W.B.	
		°C D.B.	CA	SHC	CA	SHC	CA	SHC	CA	SHC	CA	SHC	CA	SHC	CA
20 (2.2)	20.0	2.1	1.9	2.1	1.9	2.3	1.9	2.4	2.1	2.4	2.0	2.6	2.0	2.8	2.0
	22.5	2.1	1.8	2.1	1.9	2.3	1.9	2.3	2.0	2.4	2.0	2.6	2.0	2.7	2.0
	25.0	2.0	1.8	2.1	1.9	2.2	1.9	2.3	2.0	2.4	2.0	2.5	2.0	2.7	2.0
	27.5	2.0	1.8	2.1	1.9	2.2	1.9	2.3	2.0	2.4	2.0	2.5	2.0	2.7	2.0
	30.0	2.0	1.8	2.0	1.9	2.2	1.9	2.3	2.0	2.3	2.0	2.5	2.0	2.7	2.0
	32.5	2.0	1.8	2.0	1.9	2.2	1.9	2.2	2.0	2.3	2.0	2.5	2.0	2.6	2.0
	35.0	2.0	1.8	2.0	1.9	2.1	1.8	2.2	2.0	2.3	2.0	2.5	2.0	2.6	2.0
	37.5	1.9	1.8	2.0	1.8	2.1	1.8	2.2	2.0	2.3	2.0	2.4	2.0	2.6	1.9
	40.0	1.9	1.8	1.9	1.8	2.1	1.8	2.2	2.0	2.2	2.0	2.4	2.0	2.6	1.9
43.0	1.9	1.8	1.9	1.8	2.1	1.8	2.1	2.0	2.2	2.0	2.4	1.9	2.5	1.9	
25 (2.8)	20.0	2.6	2.1	2.7	2.2	2.9	2.1	3.0	2.3	3.1	2.3	3.3	2.2	3.5	2.2
	22.5	2.6	2.1	2.7	2.1	2.9	2.1	3.0	2.3	3.1	2.3	3.3	2.2	3.5	2.2
	25.0	2.6	2.1	2.7	2.1	2.9	2.1	2.9	2.3	3.0	2.3	3.2	2.2	3.5	2.2
	27.5	2.6	2.1	2.6	2.1	2.8	2.1	2.9	2.2	3.0	2.2	3.2	2.2	3.4	2.2
	30.0	2.5	2.0	2.6	2.1	2.8	2.1	2.9	2.2	3.0	2.2	3.2	2.2	3.4	2.2
	32.5	2.5	2.0	2.6	2.1	2.8	2.1	2.9	2.2	3.0	2.2	3.2	2.2	3.4	2.2
	35.0	2.5	2.0	2.5	2.1	2.7	2.1	2.8	2.2	2.9	2.2	3.1	2.2	3.3	2.2
	37.5	2.5	2.0	2.5	2.1	2.7	2.0	2.8	2.2	2.9	2.2	3.1	2.2	3.3	2.1
	40.0	2.4	2.0	2.5	2.0	2.7	2.0	2.8	2.2	2.9	2.2	3.1	2.2	3.3	2.1
43.0	2.4	2.0	2.4	2.0	2.6	2.0	2.7	2.2	2.8	2.2	3.0	2.1	3.2	2.1	
32 (3.6)	20.0	3.4	2.5	3.5	2.6	3.7	2.6	3.9	2.8	4.0	2.7	4.3	2.7	4.5	2.7
	22.5	3.4	2.5	3.5	2.6	3.7	2.6	3.8	2.7	4.0	2.7	4.2	2.7	4.5	2.7
	25.0	3.3	2.5	3.4	2.6	3.7	2.6	3.8	2.7	3.9	2.7	4.2	2.7	4.4	2.6
	27.5	3.3	2.5	3.4	2.6	3.6	2.5	3.8	2.7	3.9	2.7	4.1	2.7	4.4	2.6
	30.0	3.3	2.5	3.3	2.5	3.6	2.5	3.7	2.7	3.8	2.7	4.1	2.6	4.4	2.6
	32.5	3.2	2.5	3.3	2.5	3.5	2.5	3.7	2.7	3.8	2.7	4.1	2.6	4.3	2.6
	35.0	3.2	2.4	3.3	2.5	3.5	2.5	3.6	2.6	3.8	2.6	4.0	2.6	4.3	2.6
	37.5	3.2	2.4	3.2	2.5	3.5	2.5	3.6	2.6	3.7	2.6	4.0	2.6	4.2	2.6
	40.0	3.1	2.4	3.2	2.5	3.4	2.5	3.5	2.6	3.7	2.6	3.9	2.6	4.2	2.6
43.0	3.1	2.4	3.1	2.4	3.4	2.4	3.5	2.6	3.6	2.6	3.9	2.6	4.2	2.5	
40 (4.5)	20.0	4.3	3.4	4.4	3.5	4.7	3.5	4.8	3.7	5.0	3.7	5.3	3.7	5.7	3.6
	22.5	4.2	3.4	4.3	3.5	4.6	3.5	4.8	3.7	4.9	3.7	5.3	3.7	5.6	3.6
	25.0	4.2	3.4	4.3	3.5	4.6	3.5	4.7	3.7	4.9	3.7	5.2	3.7	5.6	3.6
	27.5	4.1	3.4	4.2	3.5	4.5	3.4	4.7	3.7	4.8	3.7	5.2	3.6	5.5	3.6
	30.0	4.1	3.3	4.2	3.4	4.5	3.4	4.6	3.7	4.8	3.6	5.1	3.6	5.5	3.6
	32.5	4.0	3.3	4.1	3.4	4.4	3.4	4.6	3.6	4.7	3.6	5.1	3.6	5.4	3.6
	35.0	4.0	3.3	4.1	3.4	4.4	3.4	4.5	3.6	4.7	3.6	5.0	3.6	5.4	3.5
	37.5	4.0	3.3	4.0	3.4	4.3	3.4	4.5	3.6	4.6	3.6	5.0	3.6	5.3	3.5
	40.0	3.9	3.3	4.0	3.3	4.3	3.3	4.4	3.6	4.6	3.6	4.9	3.5	5.3	3.5
43.0	3.9	3.2	3.9	3.3	4.2	3.3	4.4	3.6	4.5	3.5	4.9	3.5	5.2	3.5	
50 (5.6)	20.0	5.3	4.2	5.5	4.3	5.8	4.3	6.0	4.6	6.2	4.6	6.6	4.5	7.0	4.5
	22.5	5.2	4.2	5.4	4.3	5.8	4.3	6.0	4.6	6.2	4.6	6.6	4.5	7.0	4.5
	25.0	5.2	4.2	5.3	4.3	5.7	4.3	5.9	4.6	6.1	4.5	6.5	4.5	6.9	4.4
	27.5	5.1	4.1	5.3	4.3	5.6	4.2	5.8	4.5	6.0	4.5	6.4	4.5	6.9	4.4
	30.0	5.1	4.1	5.2	4.2	5.6	4.2	5.8	4.5	6.0	4.5	6.4	4.4	6.8	4.4
	32.5	5.0	4.1	5.1	4.2	5.5	4.2	5.7	4.5	5.9	4.5	6.3	4.4	6.7	4.4
	35.0	5.0	4.1	5.1	4.2	5.4	4.2	5.6	4.4	5.8	4.4	6.2	4.4	6.7	4.4
	37.5	4.9	4.0	5.0	4.1	5.4	4.1	5.6	4.4	5.8	4.4	6.2	4.4	6.6	4.3
	40.0	4.9	4.0	4.9	4.1	5.3	4.1	5.5	4.4	5.7	4.4	6.1	4.4	6.5	4.3
43.0	4.8	4.0	4.9	4.1	5.2	4.1	5.4	4.4	5.6	4.4	6.0	4.3	6.5	4.3	
63 (7.1)	20.0	6.7	5.2	6.9	5.4	7.4	5.3	7.6	5.7	7.9	5.7	8.4	5.6	8.9	5.5
	22.5	6.6	5.2	6.8	5.3	7.3	5.3	7.6	5.6	7.8	5.6	8.3	5.6	8.8	5.5
	25.0	6.6	5.1	6.8	5.3	7.2	5.3	7.5	5.6	7.7	5.6	8.2	5.5	8.8	5.5
	27.5	6.5	5.1	6.7	5.3	7.2	5.2	7.4	5.6	7.6	5.6	8.2	5.5	8.7	5.4
	30.0	6.4	5.1	6.6	5.2	7.1	5.2	7.3	5.5	7.6	5.5	8.1	5.5	8.6	5.4
	32.5	6.4	5.0	6.5	5.2	7.0	5.2	7.2	5.5	7.5	5.5	8.0	5.4	8.5	5.4
	35.0	6.3	5.0	6.4	5.1	6.9	5.1	7.1	5.5	7.4	5.5	7.9	5.4	8.5	5.4
	37.5	6.2	5.0	6.3	5.1	6.8	5.1	7.1	5.4	7.3	5.4	7.8	5.4	8.4	5.3
	40.0	6.2	5.0	6.3	5.1	6.7	5.1	7.0	5.4	7.2	5.4	7.8	5.4	8.3	5.3
43.0	6.1	4.9	6.2	5.0	6.7	5.0	6.9	5.4	7.1	5.4	7.7	5.3	8.2	5.3	
71 (8.0)	20.0	7.6	5.7	7.8	5.8	8.3	5.8	8.6	6.2	8.9	6.1	9.4	6.1	10.0	6.0
	22.5	7.5	5.6	7.7	5.8	8.2	5.8	8.5	6.1	8.8	6.1	9.4	6.0	10.0	5.9
	25.0	7.4	5.6	7.6	5.7	8.1	5.7	8.4	6.1	8.7	6.1	9.3	6.0	9.9	5.9
	27.5	7.3	5.6	7.5	5.7	8.1	5.7	8.3	6.0	8.6	6.0	9.2	6.0	9.8	5.9
	30.0	7.3	5.5	7.4	5.7	8.0	5.6	8.2	6.0	8.5	6.0	9.1	5.9	9.7	5.9
	32.5	7.2	5.5	7.3	5.6	7.9	5.6	8.2	6.0	8.4	5.9	9.0	5.9	9.6	5.8
	35.0	7.1	5.4	7.2	5.6	7.8	5.6	8.0	5.9	8.3	5.9	8.9	5.9	9.5	5.8
	37.5	7.0	5.4	7.2	5.5	7.7	5.5	8.0	5.9	8.3	5.9	8.8	5.8	9.4	5.8
	40.0	7.0	5.4	7.1	5.5	7.6	5.5	7.9	5.8	8.2	5.8	8.7	5.8	9.4	5.7
43.0	6.9	5.3	7.0	5.4	7.5	5.4	7.8	5.8	8.1	5.8	8.6	5.7	9.2	5.7	

kcal/h=kW x 860 , BTU/h = kW x 3,412

2. Cooling [Ceiling concealed (Middle static pressure type)]

PEFY-P-VMA(L)-E

CA:Capacity(kW) , SHC:Sensible Heat Capacity(kW)

Model size (Rated kW)	Outdoor air temp. °C D.B.	Indoor air temp.													
		21.5°C D.B. 15°C W.B.		23°C D.B. 16°C W.B.		25°C D.B. 18°C W.B.		27°C D.B. 19°C W.B.		28°C D.B. 20°C W.B.		30°C D.B. 22°C W.B.		32°C D.B. 24°C W.B.	
		CA	SHC	CA	SHC	CA	SHC	CA	SHC	CA	SHC	CA	SHC	CA	SHC
80 (9.0)	20.0	8.5	6.1	8.8	6.3	9.4	6.2	9.7	6.6	10.0	6.6	10.6	6.5	11.3	6.4
	22.5	8.4	6.1	8.7	6.2	9.3	6.2	9.6	6.5	9.9	6.5	10.5	6.4	11.2	6.4
	25.0	8.3	6.0	8.6	6.2	9.2	6.1	9.5	6.5	9.8	6.5	10.4	6.4	11.1	6.3
	27.5	8.3	6.0	8.5	6.1	9.1	6.1	9.4	6.4	9.7	6.4	10.3	6.4	11.0	6.3
	30.0	8.2	5.9	8.4	6.1	9.0	6.1	9.3	6.4	9.6	6.4	10.2	6.3	10.9	6.2
	32.5	8.1	5.9	8.3	6.0	8.9	6.0	9.2	6.4	9.5	6.3	10.1	6.3	10.8	6.2
	35.0	8.0	5.8	8.1	6.0	8.8	6.0	9.0	6.3	9.4	6.3	10.0	6.2	10.7	6.2
	37.5	7.9	5.8	8.0	5.9	8.7	5.9	9.0	6.3	9.3	6.2	9.9	6.2	10.6	6.1
	40.0	7.8	5.8	7.9	5.9	8.6	5.9	8.9	6.2	9.2	6.2	9.8	6.2	10.5	6.1
43.0	7.7	5.7	7.8	5.8	8.4	5.8	8.7	6.2	9.1	6.2	9.7	6.1	10.4	6.1	
100 (11.2)	20.0	10.6	8.4	10.9	8.6	11.7	8.6	12.0	9.2	12.4	9.1	13.2	9.0	14.1	8.9
	22.5	10.5	8.3	10.8	8.6	11.5	8.5	11.9	9.1	12.3	9.1	13.1	9.0	13.9	8.9
	25.0	10.4	8.3	10.6	8.5	11.4	8.5	11.8	9.1	12.2	9.0	13.0	8.9	13.8	8.8
	27.5	10.3	8.2	10.5	8.5	11.3	8.4	11.7	9.0	12.1	9.0	12.9	8.9	13.7	8.8
	30.0	10.2	8.2	10.4	8.4	11.2	8.4	11.5	9.0	11.9	8.9	12.7	8.8	13.6	8.7
	32.5	10.1	8.1	10.3	8.4	11.0	8.3	11.4	8.9	11.8	8.9	12.6	8.8	13.5	8.7
	35.0	9.9	8.1	10.1	8.3	10.9	8.3	11.2	8.8	11.7	8.8	12.5	8.7	13.3	8.7
	37.5	9.8	8.0	10.0	8.2	10.8	8.2	11.2	8.8	11.6	8.8	12.4	8.7	13.2	8.6
	40.0	9.7	8.0	9.9	8.2	10.6	8.2	11.0	8.7	11.4	8.7	12.2	8.7	13.1	8.6
43.0	9.6	7.9	9.7	8.1	10.5	8.1	10.9	8.7	11.3	8.7	12.1	8.6	12.9	8.5	
125 (14.0)	20.0	13.2	10.2	13.6	10.5	14.6	10.5	15.1	11.1	15.5	11.1	16.5	10.9	17.6	10.8
	22.5	13.1	10.1	13.5	10.4	14.4	10.4	14.9	11.1	15.4	11.0	16.4	10.9	17.4	10.7
	25.0	13.0	10.1	13.3	10.4	14.3	10.3	14.7	11.0	15.2	10.9	16.2	10.8	17.3	10.7
	27.5	12.8	10.0	13.2	10.3	14.1	10.2	14.6	10.9	15.1	10.9	16.1	10.8	17.1	10.6
	30.0	12.7	9.9	13.0	10.2	13.9	10.2	14.4	10.9	14.9	10.8	15.9	10.7	17.0	10.6
	32.5	12.6	9.9	12.8	10.1	13.8	10.1	14.3	10.8	14.8	10.7	15.8	10.7	16.8	10.5
	35.0	12.4	9.8	12.7	10.1	13.6	10.0	14.0	10.7	14.6	10.7	15.6	10.6	16.7	10.5
	37.5	12.3	9.8	12.5	10.0	13.5	10.0	14.0	10.7	14.4	10.6	15.5	10.5	16.5	10.4
	40.0	12.2	9.7	12.4	9.9	13.3	9.9	13.8	10.6	14.3	10.6	15.3	10.5	16.4	10.4
43.0	12.0	9.6	12.2	9.8	13.1	9.8	13.6	10.5	14.1	10.5	15.1	10.4	16.2	10.3	
140 (16.0)	20.0	15.1	11.5	15.6	11.9	16.7	11.8	17.2	12.6	17.8	12.5	18.9	12.4	20.1	12.2
	22.5	15.0	11.5	15.4	11.8	16.5	11.7	17.0	12.5	17.6	12.4	18.7	12.3	19.9	12.1
	25.0	14.8	11.4	15.2	11.7	16.3	11.7	16.8	12.4	17.4	12.3	18.5	12.2	19.7	12.1
	27.5	14.7	11.3	15.0	11.6	16.1	11.6	16.7	12.3	17.2	12.3	18.4	12.2	19.6	12.0
	30.0	14.5	11.2	14.9	11.5	15.9	11.5	16.5	12.2	17.0	12.2	18.2	12.1	19.4	11.9
	32.5	14.4	11.2	14.7	11.5	15.8	11.4	16.3	12.2	16.9	12.1	18.0	12.0	19.2	11.9
	35.0	14.2	11.1	14.5	11.4	15.6	11.3	16.0	12.0	16.7	12.1	17.8	12.0	19.1	11.8
	37.5	14.1	11.0	14.3	11.3	15.4	11.3	15.9	12.0	16.5	12.0	17.7	11.9	18.9	11.8
	40.0	13.9	10.9	14.1	11.2	15.2	11.2	15.8	11.9	16.3	11.9	17.5	11.8	18.7	11.7
43.0	13.7	10.9	13.9	11.1	15.0	11.1	15.6	11.9	16.1	11.8	17.3	11.7	18.5	11.6	

kcal/h=kW x 860 , BTU/h = kW x 3,412

2. Cooling [Ceiling concealed (Middle static pressure type)]

2-4. Cooling capacity with PUHY-RP700-800YSJM

PEFY-P-VMA(L)-E

CA:Capacity(kW) , SHC:Sensible Heat Capacity(kW)

Model size (Rated kW)	Outdoor air temp. °C D.B.	Indoor air temp.													
		21.5°C D.B. 15°C W.B.		23°C D.B. 16°C W.B.		25°C D.B. 18°C W.B.		27°C D.B. 19°C W.B.		28°C D.B. 20°C W.B.		30°C D.B. 22°C W.B.		32°C D.B. 24°C W.B.	
		CA	SHC	CA	SHC	CA	SHC	CA	SHC	CA	SHC	CA	SHC	CA	SHC
20 (2.2)	20.0	2.1	1.9	2.2	1.9	2.4	1.9	2.4	2.1	2.5	2.1	2.7	2.1	2.9	2.0
	22.5	2.1	1.9	2.2	1.9	2.3	1.9	2.4	2.1	2.5	2.1	2.6	2.0	2.8	2.0
	25.0	2.1	1.8	2.1	1.9	2.3	1.9	2.4	2.1	2.4	2.0	2.6	2.0	2.8	2.0
	27.5	2.0	1.8	2.1	1.9	2.2	1.9	2.3	2.0	2.4	2.0	2.6	2.0	2.7	2.0
	30.0	2.0	1.8	2.0	1.9	2.2	1.9	2.3	2.0	2.4	2.0	2.5	2.0	2.7	2.0
	32.5	1.9	1.8	2.0	1.9	2.2	1.9	2.2	2.0	2.3	2.0	2.5	2.0	2.6	2.0
	35.0	1.9	1.8	2.0	1.8	2.1	1.8	2.2	2.0	2.3	2.0	2.4	2.0	2.6	1.9
	37.5	1.9	1.8	1.9	1.8	2.1	1.8	2.1	2.0	2.2	2.0	2.4	1.9	2.5	1.9
	40.0	1.8	1.7	1.9	1.8	2.0	1.8	2.1	2.0	2.2	1.9	2.3	1.9	2.5	1.9
43.0	1.8	1.7	1.8	1.8	2.0	1.8	2.1	1.9	2.1	1.9	2.3	1.9	2.4	1.9	
25 (2.8)	20.0	2.7	2.1	2.8	2.2	3.0	2.2	3.1	2.3	3.2	2.3	3.4	2.3	3.7	2.3
	22.5	2.7	2.1	2.8	2.2	3.0	2.2	3.1	2.3	3.2	2.3	3.4	2.3	3.6	2.2
	25.0	2.6	2.1	2.7	2.1	2.9	2.1	3.0	2.3	3.1	2.3	3.3	2.3	3.5	2.2
	27.5	2.6	2.1	2.7	2.1	2.9	2.1	3.0	2.3	3.1	2.3	3.3	2.2	3.5	2.2
	30.0	2.5	2.0	2.6	2.1	2.8	2.1	2.9	2.2	3.0	2.2	3.2	2.2	3.4	2.2
	32.5	2.5	2.0	2.6	2.1	2.7	2.1	2.8	2.2	2.9	2.2	3.1	2.2	3.3	2.2
	35.0	2.4	2.0	2.5	2.1	2.7	2.1	2.8	2.2	2.9	2.2	3.1	2.2	3.3	2.1
	37.5	2.4	2.0	2.5	2.0	2.6	2.0	2.7	2.2	2.8	2.2	3.0	2.1	3.2	2.1
	40.0	2.3	1.9	2.4	2.0	2.6	2.0	2.7	2.1	2.8	2.1	3.0	2.1	3.1	2.1
43.0	2.3	1.9	2.4	2.0	2.5	2.0	2.6	2.1	2.7	2.1	2.9	2.1	3.1	2.1	
32 (3.6)	20.0	3.5	2.6	3.6	2.7	3.9	2.7	4.0	2.8	4.1	2.8	4.4	2.8	4.7	2.7
	22.5	3.4	2.5	3.5	2.6	3.8	2.6	3.9	2.8	4.1	2.8	4.3	2.7	4.6	2.7
	25.0	3.4	2.5	3.5	2.6	3.7	2.6	3.9	2.8	4.0	2.7	4.3	2.7	4.5	2.7
	27.5	3.3	2.5	3.4	2.6	3.7	2.6	3.8	2.7	3.9	2.7	4.2	2.7	4.5	2.6
	30.0	3.2	2.5	3.4	2.5	3.6	2.5	3.7	2.7	3.9	2.7	4.1	2.7	4.4	2.6
	32.5	3.2	2.4	3.3	2.5	3.5	2.5	3.7	2.7	3.8	2.7	4.0	2.6	4.3	2.6
	35.0	3.1	2.4	3.2	2.5	3.5	2.5	3.6	2.6	3.7	2.6	4.0	2.6	4.2	2.6
	37.5	3.1	2.4	3.2	2.4	3.4	2.4	3.5	2.6	3.6	2.6	3.9	2.6	4.1	2.5
	40.0	3.0	2.3	3.1	2.4	3.3	2.4	3.4	2.6	3.6	2.6	3.8	2.5	4.0	2.5
43.0	2.9	2.3	3.0	2.4	3.2	2.4	3.4	2.5	3.5	2.5	3.7	2.5	3.9	2.5	
40 (4.5)	20.0	4.3	3.5	4.5	3.6	4.8	3.6	5.0	3.8	5.2	3.8	5.5	3.8	5.9	3.7
	22.5	4.3	3.4	4.4	3.6	4.7	3.5	4.9	3.8	5.1	3.8	5.4	3.7	5.8	3.7
	25.0	4.2	3.4	4.3	3.5	4.7	3.5	4.8	3.7	5.0	3.7	5.3	3.7	5.7	3.6
	27.5	4.1	3.4	4.3	3.5	4.6	3.5	4.7	3.7	4.9	3.7	5.2	3.7	5.6	3.6
	30.0	4.1	3.3	4.2	3.4	4.5	3.4	4.7	3.7	4.8	3.7	5.1	3.6	5.5	3.6
	32.5	4.0	3.3	4.1	3.4	4.4	3.4	4.6	3.6	4.7	3.6	5.0	3.6	5.4	3.5
	35.0	3.9	3.3	4.0	3.4	4.3	3.4	4.5	3.6	4.6	3.6	4.9	3.6	5.3	3.5
	37.5	3.8	3.2	4.0	3.3	4.2	3.3	4.4	3.6	4.5	3.6	4.8	3.5	5.2	3.5
	40.0	3.8	3.2	3.9	3.3	4.2	3.3	4.3	3.5	4.5	3.5	4.8	3.5	5.1	3.4
43.0	3.7	3.2	3.8	3.3	4.1	3.2	4.2	3.5	4.3	3.5	4.6	3.4	4.9	3.4	
50 (5.6)	20.0	5.4	4.3	5.6	4.4	6.0	4.4	6.2	4.7	6.4	4.7	6.9	4.6	7.3	4.6
	22.5	5.3	4.2	5.5	4.4	5.9	4.4	6.1	4.6	6.3	4.6	6.7	4.6	7.2	4.5
	25.0	5.2	4.2	5.4	4.3	5.8	4.3	6.0	4.6	6.2	4.6	6.6	4.5	7.0	4.5
	27.5	5.1	4.1	5.3	4.3	5.7	4.3	5.9	4.6	6.1	4.5	6.5	4.5	6.9	4.4
	30.0	5.0	4.1	5.2	4.2	5.6	4.2	5.8	4.5	6.0	4.5	6.4	4.5	6.8	4.4
	32.5	5.0	4.0	5.1	4.2	5.5	4.2	5.7	4.5	5.9	4.5	6.3	4.4	6.7	4.4
	35.0	4.9	4.0	5.0	4.1	5.4	4.1	5.6	4.4	5.8	4.4	6.2	4.4	6.5	4.3
	37.5	4.8	4.0	4.9	4.1	5.3	4.1	5.5	4.4	5.7	4.4	6.0	4.3	6.4	4.3
	40.0	4.7	3.9	4.8	4.1	5.2	4.0	5.4	4.3	5.5	4.3	5.9	4.3	6.3	4.2
43.0	4.6	3.9	4.7	4.0	5.1	4.0	5.2	4.3	5.4	4.3	5.8	4.2	6.1	4.2	
63 (7.1)	20.0	6.9	5.3	7.1	5.5	7.6	5.4	7.9	5.8	8.2	5.8	8.7	5.7	9.3	5.6
	22.5	6.7	5.2	7.0	5.4	7.5	5.4	7.8	5.7	8.0	5.7	8.6	5.7	9.1	5.6
	25.0	6.6	5.2	6.9	5.3	7.4	5.3	7.6	5.7	7.9	5.7	8.4	5.6	8.9	5.5
	27.5	6.5	5.1	6.7	5.3	7.2	5.3	7.5	5.6	7.7	5.6	8.3	5.5	8.8	5.5
	30.0	6.4	5.1	6.6	5.2	7.1	5.2	7.3	5.6	7.6	5.5	8.1	5.5	8.6	5.4
	32.5	6.3	5.0	6.5	5.2	7.0	5.2	7.2	5.5	7.5	5.5	7.9	5.4	8.5	5.4
	35.0	6.2	4.9	6.4	5.1	6.8	5.1	7.1	5.5	7.3	5.4	7.8	5.4	8.3	5.3
	37.5	6.1	4.9	6.2	5.1	6.7	5.0	6.9	5.4	7.2	5.4	7.6	5.3	8.1	5.2
	40.0	5.9	4.8	6.1	5.0	6.6	5.0	6.8	5.3	7.0	5.3	7.5	5.3	8.0	5.2
43.0	5.8	4.8	6.0	4.9	6.4	4.9	6.6	5.3	6.9	5.2	7.3	5.2	7.8	5.1	
71 (8.0)	20.0	7.7	5.8	8.0	5.9	8.6	5.9	8.9	6.3	9.2	6.3	9.8	6.2	10.4	6.1
	22.5	7.6	5.7	7.9	5.9	8.4	5.9	8.7	6.2	9.0	6.2	9.6	6.1	10.3	6.1
	25.0	7.5	5.6	7.7	5.8	8.3	5.8	8.6	6.1	8.9	6.1	9.5	6.1	10.1	6.0
	27.5	7.3	5.6	7.6	5.7	8.1	5.7	8.4	6.1	8.7	6.1	9.3	6.0	9.9	5.9
	30.0	7.2	5.5	7.4	5.7	8.0	5.7	8.3	6.0	8.6	6.0	9.1	5.9	9.7	5.9
	32.5	7.1	5.4	7.3	5.6	7.8	5.6	8.1	5.9	8.4	5.9	9.0	5.9	9.5	5.8
	35.0	6.9	5.4	7.2	5.5	7.7	5.5	8.0	5.9	8.2	5.9	8.8	5.8	9.3	5.7
	37.5	6.8	5.3	7.0	5.5	7.5	5.5	7.8	5.8	8.1	5.8	8.6	5.7	9.2	5.7
	40.0	6.7	5.2	6.9	5.4	7.4	5.4	7.7	5.8	7.9	5.7	8.4	5.7	9.0	5.6
43.0	6.5	5.2	6.7	5.3	7.2	5.3	7.5	5.7	7.7	5.7	8.2	5.6	8.8	5.5	

kcal/h=kW x 860 , BTU/h = kW x 3,412

2. Cooling [Ceiling concealed (Middle static pressure type)]

PEFY-P-VMA(L)-E

CA:Capacity(kW) , SHC:Sensible Heat Capacity(kW)

Model size (Rated kW)	Outdoor air temp. °C D.B.	Indoor air temp.													
		21.5°C D.B. 15°C W.B.		23°C D.B. 16°C W.B.		25°C D.B. 18°C W.B.		27°C D.B. 19°C W.B.		28°C D.B. 20°C W.B.		30°C D.B. 22°C W.B.		32°C D.B. 24°C W.B.	
		CA	SHC	CA	SHC	CA	SHC	CA	SHC	CA	SHC	CA	SHC	CA	SHC
80 (9.0)	20.0	8.7	6.2	9.0	6.4	9.7	6.4	10.0	6.7	10.3	6.7	11.0	6.6	11.7	6.6
	22.5	8.5	6.1	8.9	6.3	9.5	6.3	9.8	6.7	10.2	6.6	10.8	6.6	11.5	6.5
	25.0	8.4	6.1	8.7	6.2	9.3	6.2	9.7	6.6	10.0	6.6	10.6	6.5	11.3	6.4
	27.5	8.3	6.0	8.5	6.2	9.2	6.1	9.5	6.5	9.8	6.5	10.5	6.4	11.1	6.3
	30.0	8.1	5.9	8.4	6.1	9.0	6.1	9.3	6.4	9.6	6.4	10.3	6.3	10.9	6.3
	32.5	8.0	5.8	8.2	6.0	8.8	6.0	9.1	6.3	9.4	6.3	10.1	6.3	10.7	6.2
	35.0	7.8	5.8	8.1	5.9	8.7	5.9	9.0	6.3	9.3	6.2	9.9	6.2	10.5	6.1
	37.5	7.7	5.7	7.9	5.8	8.5	5.8	8.8	6.2	9.1	6.2	9.7	6.1	10.3	6.0
	40.0	7.5	5.6	7.7	5.8	8.3	5.8	8.6	6.1	8.9	6.1	9.5	6.0	10.1	6.0
43.0	7.4	5.5	7.6	5.7	8.1	5.7	8.4	6.0	8.7	6.0	9.3	5.9	9.9	5.9	
100 (11.2)	20.0	10.8	8.5	11.2	8.8	12.0	8.8	12.5	9.3	12.9	9.3	13.7	9.2	14.6	9.1
	22.5	10.6	8.4	11.0	8.7	11.8	8.7	12.2	9.2	12.6	9.2	13.5	9.1	14.4	9.0
	25.0	10.5	8.3	10.8	8.6	11.6	8.6	12.0	9.2	12.4	9.1	13.3	9.0	14.1	8.9
	27.5	10.3	8.2	10.6	8.5	11.4	8.5	11.8	9.1	12.2	9.0	13.0	8.9	13.8	8.8
	30.0	10.1	8.1	10.4	8.4	11.2	8.4	11.6	9.0	12.0	8.9	12.8	8.9	13.6	8.7
	32.5	9.9	8.1	10.2	8.3	11.0	8.3	11.4	8.9	11.8	8.9	12.5	8.8	13.3	8.7
	35.0	9.7	8.0	10.0	8.2	10.8	8.2	11.2	8.8	11.5	8.8	12.3	8.7	13.1	8.6
	37.5	9.5	7.9	9.8	8.2	10.6	8.1	10.9	8.7	11.3	8.7	12.1	8.6	12.8	8.5
	40.0	9.4	7.8	9.6	8.1	10.4	8.0	10.7	8.6	11.1	8.6	11.8	8.5	12.6	8.4
43.0	9.2	7.7	9.4	8.0	10.1	7.9	10.5	8.5	10.8	8.5	11.5	8.4	12.3	8.3	
125 (14.0)	20.0	13.5	10.3	14.0	10.7	15.0	10.7	15.6	11.3	16.1	11.3	17.2	11.2	18.3	11.0
	22.5	13.3	10.2	13.8	10.6	14.8	10.5	15.3	11.2	15.8	11.2	16.9	11.1	17.9	10.9
	25.0	13.1	10.1	13.5	10.5	14.5	10.4	15.0	11.1	15.5	11.1	16.6	11.0	17.6	10.8
	27.5	12.8	10.0	13.3	10.3	14.3	10.3	14.8	11.0	15.3	11.0	16.3	10.8	17.3	10.7
	30.0	12.6	9.9	13.0	10.2	14.0	10.2	14.5	10.9	15.0	10.8	16.0	10.7	17.0	10.6
	32.5	12.4	9.8	12.8	10.1	13.7	10.1	14.2	10.8	14.7	10.7	15.7	10.6	16.7	10.5
	35.0	12.2	9.7	12.5	10.0	13.5	10.0	14.0	10.7	14.4	10.6	15.4	10.5	16.4	10.4
	37.5	11.9	9.6	12.3	9.9	13.2	9.9	13.7	10.5	14.1	10.5	15.1	10.4	16.0	10.3
	40.0	11.7	9.5	12.1	9.8	12.9	9.8	13.4	10.4	13.9	10.4	14.8	10.3	15.7	10.2
43.0	11.4	9.3	11.8	9.7	12.6	9.6	13.1	10.3	13.5	10.3	14.4	10.2	15.4	10.0	
140 (16.0)	20.0	15.5	11.7	16.0	12.1	17.2	12.1	17.8	12.8	18.4	12.8	19.6	12.6	20.9	12.5
	22.5	15.2	11.6	15.7	12.0	16.9	11.9	17.5	12.7	18.1	12.6	19.3	12.5	20.5	12.3
	25.0	14.9	11.4	15.5	11.8	16.6	11.8	17.2	12.5	17.8	12.5	18.9	12.4	20.1	12.2
	27.5	14.7	11.3	15.2	11.7	16.3	11.7	16.9	12.4	17.4	12.4	18.6	12.2	19.8	12.1
	30.0	14.4	11.2	14.9	11.6	16.0	11.5	16.6	12.3	17.1	12.2	18.3	12.1	19.4	12.0
	32.5	14.2	11.1	14.6	11.4	15.7	11.4	16.2	12.1	16.8	12.1	17.9	12.0	19.1	11.8
	35.0	13.9	10.9	14.3	11.3	15.4	11.3	16.0	12.0	16.5	12.0	17.6	11.9	18.7	11.7
	37.5	13.6	10.8	14.1	11.2	15.1	11.1	15.6	11.9	16.2	11.8	17.2	11.7	18.3	11.6
	40.0	13.4	10.7	13.8	11.0	14.8	11.0	15.3	11.8	15.8	11.7	16.9	11.6	18.0	11.5
43.0	13.1	10.6	13.4	10.9	14.4	10.9	14.9	11.6	15.5	11.6	16.5	11.5	17.6	11.3	

kcal/h=kW x 860 , BTU/h = kW x 3,412

2. Cooling [Ceiling concealed (Middle static pressure type)]

2-5. Cooling capacity with PUHY-RP850-900YSJM

PEFY-P-VMA(L)-E

CA:Capacity(kW) , SHC:Sensible Heat Capacity(kW)

Model size (Rated kW)	Outdoor air temp. °C D.B.	Indoor air temp.													
		21.5°C D.B. 15°C W.B.		23°C D.B. 16°C W.B.		25°C D.B. 18°C W.B.		27°C D.B. 19°C W.B.		28°C D.B. 20°C W.B.		30°C D.B. 22°C W.B.		32°C D.B. 24°C W.B.	
		CA	SHC	CA	SHC	CA	SHC	CA	SHC	CA	SHC	CA	SHC	CA	SHC
20 (2.2)	20.0	2.1	1.9	2.1	1.9	2.3	1.9	2.4	2.1	2.4	2.0	2.6	2.0	2.8	2.0
	22.5	2.1	1.8	2.1	1.9	2.3	1.9	2.3	2.0	2.4	2.0	2.6	2.0	2.7	2.0
	25.0	2.0	1.8	2.1	1.9	2.2	1.9	2.3	2.0	2.4	2.0	2.5	2.0	2.7	2.0
	27.5	2.0	1.8	2.1	1.9	2.2	1.9	2.3	2.0	2.4	2.0	2.5	2.0	2.7	2.0
	30.0	2.0	1.8	2.0	1.9	2.2	1.9	2.3	2.0	2.3	2.0	2.5	2.0	2.7	2.0
	32.5	2.0	1.8	2.0	1.9	2.2	1.9	2.2	2.0	2.3	2.0	2.5	2.0	2.6	2.0
	35.0	2.0	1.8	2.0	1.9	2.1	1.8	2.2	2.0	2.3	2.0	2.5	2.0	2.6	2.0
	37.5	1.9	1.8	2.0	1.8	2.1	1.8	2.2	2.0	2.3	2.0	2.4	2.0	2.6	1.9
	40.0	1.9	1.8	1.9	1.8	2.1	1.8	2.2	2.0	2.2	2.0	2.4	2.0	2.6	1.9
43.0	1.9	1.8	1.9	1.8	2.1	1.8	2.1	2.0	2.2	2.0	2.4	1.9	2.5	1.9	
25 (2.8)	20.0	2.6	2.1	2.7	2.2	2.9	2.1	3.0	2.3	3.1	2.3	3.3	2.2	3.5	2.2
	22.5	2.6	2.1	2.7	2.1	2.9	2.1	3.0	2.3	3.1	2.3	3.3	2.2	3.5	2.2
	25.0	2.6	2.1	2.7	2.1	2.9	2.1	2.9	2.3	3.0	2.3	3.2	2.2	3.5	2.2
	27.5	2.6	2.1	2.6	2.1	2.8	2.1	2.9	2.2	3.0	2.2	3.2	2.2	3.4	2.2
	30.0	2.5	2.0	2.6	2.1	2.8	2.1	2.9	2.2	3.0	2.2	3.2	2.2	3.4	2.2
	32.5	2.5	2.0	2.6	2.1	2.8	2.1	2.9	2.2	3.0	2.2	3.2	2.2	3.4	2.2
	35.0	2.5	2.0	2.5	2.1	2.7	2.1	2.8	2.2	2.9	2.2	3.1	2.2	3.3	2.2
	37.5	2.5	2.0	2.5	2.1	2.7	2.0	2.8	2.2	2.9	2.2	3.1	2.2	3.3	2.1
	40.0	2.4	2.0	2.5	2.0	2.7	2.0	2.8	2.2	2.9	2.2	3.1	2.2	3.3	2.1
43.0	2.4	2.0	2.4	2.0	2.6	2.0	2.7	2.2	2.8	2.2	3.0	2.1	3.2	2.1	
32 (3.6)	20.0	3.4	2.5	3.5	2.6	3.7	2.6	3.9	2.8	4.0	2.7	4.3	2.7	4.5	2.7
	22.5	3.4	2.5	3.5	2.6	3.7	2.6	3.8	2.7	4.0	2.7	4.2	2.7	4.5	2.7
	25.0	3.3	2.5	3.4	2.6	3.7	2.6	3.8	2.7	3.9	2.7	4.2	2.7	4.4	2.6
	27.5	3.3	2.5	3.4	2.6	3.6	2.5	3.8	2.7	3.9	2.7	4.1	2.7	4.4	2.6
	30.0	3.3	2.5	3.3	2.5	3.6	2.5	3.7	2.7	3.8	2.7	4.1	2.6	4.4	2.6
	32.5	3.2	2.5	3.3	2.5	3.5	2.5	3.7	2.7	3.8	2.7	4.1	2.6	4.3	2.6
	35.0	3.2	2.4	3.3	2.5	3.5	2.5	3.6	2.6	3.8	2.6	4.0	2.6	4.3	2.6
	37.5	3.2	2.4	3.2	2.5	3.5	2.5	3.6	2.6	3.7	2.6	4.0	2.6	4.2	2.6
	40.0	3.1	2.4	3.2	2.5	3.4	2.5	3.5	2.6	3.7	2.6	3.9	2.6	4.2	2.6
43.0	3.1	2.4	3.1	2.4	3.4	2.4	3.5	2.6	3.6	2.6	3.9	2.6	4.2	2.5	
40 (4.5)	20.0	4.3	3.4	4.4	3.5	4.7	3.5	4.8	3.7	5.0	3.7	5.3	3.7	5.7	3.6
	22.5	4.2	3.4	4.3	3.5	4.6	3.5	4.8	3.7	4.9	3.7	5.3	3.7	5.6	3.6
	25.0	4.2	3.4	4.3	3.5	4.6	3.5	4.7	3.7	4.9	3.7	5.2	3.7	5.6	3.6
	27.5	4.1	3.4	4.2	3.5	4.5	3.4	4.7	3.7	4.8	3.7	5.2	3.6	5.5	3.6
	30.0	4.1	3.3	4.2	3.4	4.5	3.4	4.6	3.7	4.8	3.6	5.1	3.6	5.5	3.6
	32.5	4.0	3.3	4.1	3.4	4.4	3.4	4.6	3.6	4.7	3.6	5.1	3.6	5.4	3.6
	35.0	4.0	3.3	4.1	3.4	4.4	3.4	4.5	3.6	4.7	3.6	5.0	3.6	5.4	3.5
	37.5	4.0	3.3	4.0	3.4	4.3	3.4	4.5	3.6	4.6	3.6	5.0	3.6	5.3	3.5
	40.0	3.9	3.3	4.0	3.3	4.3	3.3	4.4	3.6	4.6	3.6	4.9	3.5	5.3	3.5
43.0	3.9	3.2	3.9	3.3	4.2	3.3	4.4	3.6	4.5	3.5	4.9	3.5	5.2	3.5	
50 (5.6)	20.0	5.3	4.2	5.5	4.3	5.8	4.3	6.0	4.6	6.2	4.6	6.6	4.5	7.0	4.5
	22.5	5.2	4.2	5.4	4.3	5.8	4.3	6.0	4.6	6.2	4.6	6.6	4.5	7.0	4.5
	25.0	5.2	4.2	5.3	4.3	5.7	4.3	5.9	4.6	6.1	4.5	6.5	4.5	6.9	4.4
	27.5	5.1	4.1	5.3	4.3	5.6	4.2	5.8	4.5	6.0	4.5	6.4	4.5	6.9	4.4
	30.0	5.1	4.1	5.2	4.2	5.6	4.2	5.8	4.5	6.0	4.5	6.4	4.4	6.8	4.4
	32.5	5.0	4.1	5.1	4.2	5.5	4.2	5.7	4.5	5.9	4.5	6.3	4.4	6.7	4.4
	35.0	5.0	4.1	5.1	4.2	5.4	4.2	5.6	4.4	5.8	4.4	6.2	4.4	6.7	4.4
	37.5	4.9	4.0	5.0	4.1	5.4	4.1	5.6	4.4	5.8	4.4	6.2	4.4	6.6	4.3
	40.0	4.9	4.0	4.9	4.1	5.3	4.1	5.5	4.4	5.7	4.4	6.1	4.4	6.5	4.3
43.0	4.8	4.0	4.9	4.1	5.2	4.1	5.4	4.4	5.6	4.4	6.0	4.3	6.5	4.3	
63 (7.1)	20.0	6.7	5.2	6.9	5.4	7.4	5.3	7.6	5.7	7.9	5.7	8.4	5.6	8.9	5.5
	22.5	6.6	5.2	6.8	5.3	7.3	5.3	7.6	5.6	7.8	5.6	8.3	5.6	8.8	5.5
	25.0	6.6	5.1	6.8	5.3	7.2	5.3	7.5	5.6	7.7	5.6	8.2	5.5	8.8	5.5
	27.5	6.5	5.1	6.7	5.3	7.2	5.2	7.4	5.6	7.6	5.6	8.2	5.5	8.7	5.4
	30.0	6.4	5.1	6.6	5.2	7.1	5.2	7.3	5.5	7.6	5.5	8.1	5.5	8.6	5.4
	32.5	6.4	5.0	6.5	5.2	7.0	5.2	7.2	5.5	7.5	5.5	8.0	5.4	8.5	5.4
	35.0	6.3	5.0	6.4	5.1	6.9	5.1	7.1	5.5	7.4	5.5	7.9	5.4	8.5	5.4
	37.5	6.2	5.0	6.3	5.1	6.8	5.1	7.1	5.4	7.3	5.4	7.8	5.4	8.4	5.3
	40.0	6.2	5.0	6.3	5.1	6.7	5.1	7.0	5.4	7.2	5.4	7.8	5.4	8.3	5.3
43.0	6.1	4.9	6.2	5.0	6.7	5.0	6.9	5.4	7.1	5.4	7.7	5.3	8.2	5.3	
71 (8.0)	20.0	7.6	5.7	7.8	5.8	8.3	5.8	8.6	6.2	8.9	6.1	9.4	6.1	10.0	6.0
	22.5	7.5	5.6	7.7	5.8	8.2	5.8	8.5	6.1	8.8	6.1	9.4	6.0	10.0	5.9
	25.0	7.4	5.6	7.6	5.7	8.1	5.7	8.4	6.1	8.7	6.1	9.3	6.0	9.9	5.9
	27.5	7.3	5.6	7.5	5.7	8.1	5.7	8.3	6.0	8.6	6.0	9.2	6.0	9.8	5.9
	30.0	7.3	5.5	7.4	5.7	8.0	5.6	8.2	6.0	8.5	6.0	9.1	5.9	9.7	5.9
	32.5	7.2	5.5	7.3	5.6	7.9	5.6	8.2	6.0	8.4	5.9	9.0	5.9	9.6	5.8
	35.0	7.1	5.4	7.2	5.6	7.8	5.6	8.0	5.9	8.3	5.9	8.9	5.9	9.5	5.8
	37.5	7.0	5.4	7.2	5.5	7.7	5.5	8.0	5.9	8.3	5.9	8.8	5.8	9.4	5.8
	40.0	7.0	5.4	7.1	5.5	7.6	5.5	7.9	5.8	8.2	5.8	8.7	5.8	9.4	5.7
43.0	6.9	5.3	7.0	5.4	7.5	5.4	7.8	5.8	8.1	5.8	8.6	5.7	9.2	5.7	

kcal/h=kW x 860 , BTU/h = kW x 3,412

2. Cooling [Ceiling concealed (Middle static pressure type)]

PEFY-P-VMA(L)-E

CA:Capacity(kW) , SHC:Sensible Heat Capacity(kW)

Model size (Rated kW)	Outdoor air temp. °C D.B.	Indoor air temp.													
		21.5°C D.B. 15°C W.B.		23°C D.B. 16°C W.B.		25°C D.B. 18°C W.B.		27°C D.B. 19°C W.B.		28°C D.B. 20°C W.B.		30°C D.B. 22°C W.B.		32°C D.B. 24°C W.B.	
		CA	SHC	CA	SHC	CA	SHC	CA	SHC	CA	SHC	CA	SHC	CA	SHC
80 (9.0)	20.0	8.5	6.1	8.8	6.3	9.4	6.2	9.7	6.6	10.0	6.6	10.6	6.5	11.3	6.4
	22.5	8.4	6.1	8.7	6.2	9.3	6.2	9.6	6.5	9.9	6.5	10.5	6.4	11.2	6.4
	25.0	8.3	6.0	8.6	6.2	9.2	6.1	9.5	6.5	9.8	6.5	10.4	6.4	11.1	6.3
	27.5	8.3	6.0	8.5	6.1	9.1	6.1	9.4	6.4	9.7	6.4	10.3	6.4	11.0	6.3
	30.0	8.2	5.9	8.4	6.1	9.0	6.1	9.3	6.4	9.6	6.4	10.2	6.3	10.9	6.2
	32.5	8.1	5.9	8.3	6.0	8.9	6.0	9.2	6.4	9.5	6.3	10.1	6.3	10.8	6.2
	35.0	8.0	5.8	8.1	6.0	8.8	6.0	9.0	6.3	9.4	6.3	10.0	6.2	10.7	6.2
	37.5	7.9	5.8	8.0	5.9	8.7	5.9	9.0	6.3	9.3	6.2	9.9	6.2	10.6	6.1
	40.0	7.8	5.8	7.9	5.9	8.6	5.9	8.9	6.2	9.2	6.2	9.8	6.2	10.5	6.1
43.0	7.7	5.7	7.8	5.8	8.4	5.8	8.7	6.2	9.1	6.2	9.7	6.1	10.4	6.1	
100 (11.2)	20.0	10.6	8.4	10.9	8.6	11.7	8.6	12.0	9.2	12.4	9.1	13.2	9.0	14.1	8.9
	22.5	10.5	8.3	10.8	8.6	11.5	8.5	11.9	9.1	12.3	9.1	13.1	9.0	13.9	8.9
	25.0	10.4	8.3	10.6	8.5	11.4	8.5	11.8	9.1	12.2	9.0	13.0	8.9	13.8	8.8
	27.5	10.3	8.2	10.5	8.5	11.3	8.4	11.7	9.0	12.1	9.0	12.9	8.9	13.7	8.8
	30.0	10.2	8.2	10.4	8.4	11.2	8.4	11.5	9.0	11.9	8.9	12.7	8.8	13.6	8.7
	32.5	10.1	8.1	10.3	8.4	11.0	8.3	11.4	8.9	11.8	8.9	12.6	8.8	13.5	8.7
	35.0	9.9	8.1	10.1	8.3	10.9	8.3	11.2	8.8	11.7	8.8	12.5	8.7	13.3	8.7
	37.5	9.8	8.0	10.0	8.2	10.8	8.2	11.2	8.8	11.6	8.8	12.4	8.7	13.2	8.6
	40.0	9.7	8.0	9.9	8.2	10.6	8.2	11.0	8.7	11.4	8.7	12.2	8.7	13.1	8.6
43.0	9.6	7.9	9.7	8.1	10.5	8.1	10.9	8.7	11.3	8.7	12.1	8.6	12.9	8.5	
125 (14.0)	20.0	13.2	10.2	13.6	10.5	14.6	10.5	15.1	11.1	15.5	11.1	16.5	10.9	17.6	10.8
	22.5	13.1	10.1	13.5	10.4	14.4	10.4	14.9	11.1	15.4	11.0	16.4	10.9	17.4	10.7
	25.0	13.0	10.1	13.3	10.4	14.3	10.3	14.7	11.0	15.2	10.9	16.2	10.8	17.3	10.7
	27.5	12.8	10.0	13.2	10.3	14.1	10.2	14.6	10.9	15.1	10.9	16.1	10.8	17.1	10.6
	30.0	12.7	9.9	13.0	10.2	13.9	10.2	14.4	10.9	14.9	10.8	15.9	10.7	17.0	10.6
	32.5	12.6	9.9	12.8	10.1	13.8	10.1	14.3	10.8	14.8	10.7	15.8	10.7	16.8	10.5
	35.0	12.4	9.8	12.7	10.1	13.6	10.0	14.0	10.7	14.6	10.7	15.6	10.6	16.7	10.5
	37.5	12.3	9.8	12.5	10.0	13.5	10.0	14.0	10.7	14.4	10.6	15.5	10.5	16.5	10.4
	40.0	12.2	9.7	12.4	9.9	13.3	9.9	13.8	10.6	14.3	10.6	15.3	10.5	16.4	10.4
43.0	12.0	9.6	12.2	9.8	13.1	9.8	13.6	10.5	14.1	10.5	15.1	10.4	16.2	10.3	
140 (16.0)	20.0	15.1	11.5	15.6	11.9	16.7	11.8	17.2	12.6	17.8	12.5	18.9	12.4	20.1	12.2
	22.5	15.0	11.5	15.4	11.8	16.5	11.7	17.0	12.5	17.6	12.4	18.7	12.3	19.9	12.1
	25.0	14.8	11.4	15.2	11.7	16.3	11.7	16.8	12.4	17.4	12.3	18.5	12.2	19.7	12.1
	27.5	14.7	11.3	15.0	11.6	16.1	11.6	16.7	12.3	17.2	12.3	18.4	12.2	19.6	12.0
	30.0	14.5	11.2	14.9	11.5	15.9	11.5	16.5	12.2	17.0	12.2	18.2	12.1	19.4	11.9
	32.5	14.4	11.2	14.7	11.5	15.8	11.4	16.3	12.2	16.9	12.1	18.0	12.0	19.2	11.9
	35.0	14.2	11.1	14.5	11.4	15.6	11.3	16.0	12.0	16.7	12.1	17.8	12.0	19.1	11.8
	37.5	14.1	11.0	14.3	11.3	15.4	11.3	15.9	12.0	16.5	12.0	17.7	11.9	18.9	11.8
	40.0	13.9	10.9	14.1	11.2	15.2	11.2	15.8	11.9	16.3	11.9	17.5	11.8	18.7	11.7
43.0	13.7	10.9	13.9	11.1	15.0	11.1	15.6	11.9	16.1	11.8	17.3	11.7	18.5	11.6	

kcal/h=kW x 860 , BTU/h = kW x 3,412

3. Cooling [Ceiling cassette (1-way flow type)]

3-1. Cooling capacity with PUHY,PURY-RP200-250YJM

PMFY-P-VBM-E

CA:Capacity(kW) , SHC:Sensible Heat Capacity(kW)

Model size (Rated kW)	Outdoor air temp. °C D.B.	Indoor air temp.													
		21.5°C D.B. 15°C W.B.		23°C D.B. 16°C W.B.		25°C D.B. 18°C W.B.		27°C D.B. 19°C W.B.		28°C D.B. 20°C W.B.		30°C D.B. 22°C W.B.		32°C D.B. 24°C W.B.	
		CA	SHC	CA	SHC	CA	SHC	CA	SHC	CA	SHC	CA	SHC	CA	SHC
20 (2.2)	20.0	2.1	1.8	2.2	1.9	2.3	1.9	2.4	2.0	2.5	2.0	2.6	2.0	2.8	1.9
	22.5	2.1	1.8	2.2	1.9	2.3	1.9	2.4	2.0	2.5	2.0	2.6	2.0	2.8	1.9
	25.0	2.1	1.8	2.2	1.9	2.3	1.9	2.4	2.0	2.4	2.0	2.6	2.0	2.7	1.9
	27.5	2.1	1.8	2.1	1.9	2.3	1.9	2.3	2.0	2.4	2.0	2.5	1.9	2.7	1.9
	30.0	2.0	1.8	2.1	1.9	2.2	1.8	2.3	2.0	2.3	2.0	2.5	1.9	2.6	1.9
	32.5	2.0	1.8	2.1	1.8	2.2	1.8	2.2	2.0	2.3	1.9	2.4	1.9	2.6	1.9
	35.0	2.0	1.8	2.0	1.8	2.1	1.8	2.2	1.9	2.3	1.9	2.4	1.9	2.5	1.9
	37.5	1.9	1.7	2.0	1.8	2.1	1.8	2.2	1.9	2.2	1.9	2.3	1.9	2.5	1.8
	40.0	1.9	1.7	2.0	1.8	2.1	1.8	2.1	1.9	2.2	1.9	2.3	1.9	2.4	1.8
43.0	1.8	1.7	1.9	1.8	2.0	1.7	2.1	1.9	2.1	1.9	2.2	1.8	2.3	1.8	
25 (2.8)	20.0	2.7	2.2	2.8	2.3	2.9	2.3	3.0	2.5	3.1	2.4	3.3	2.4	3.5	2.4
	22.5	2.7	2.2	2.8	2.3	2.9	2.3	3.0	2.5	3.1	2.4	3.3	2.4	3.5	2.4
	25.0	2.7	2.2	2.8	2.3	2.9	2.3	3.0	2.4	3.1	2.4	3.3	2.4	3.5	2.4
	27.5	2.7	2.2	2.7	2.3	2.9	2.3	3.0	2.4	3.0	2.4	3.2	2.4	3.4	2.3
	30.0	2.6	2.2	2.7	2.3	2.8	2.2	2.9	2.4	3.0	2.4	3.2	2.3	3.3	2.3
	32.5	2.6	2.2	2.6	2.3	2.8	2.2	2.9	2.4	2.9	2.4	3.1	2.3	3.3	2.3
	35.0	2.5	2.2	2.6	2.2	2.7	2.2	2.8	2.4	2.9	2.3	3.0	2.3	3.2	2.3
	37.5	2.5	2.1	2.5	2.2	2.7	2.2	2.8	2.3	2.8	2.3	3.0	2.3	3.1	2.2
	40.0	2.4	2.1	2.5	2.2	2.6	2.2	2.7	2.3	2.8	2.3	2.9	2.3	3.1	2.2
43.0	2.4	2.1	2.4	2.2	2.6	2.1	2.6	2.3	2.7	2.3	2.8	2.2	3.0	2.2	
32 (3.6)	20.0	3.4	2.6	3.5	2.6	3.8	2.6	3.9	2.8	4.0	2.8	4.3	2.7	4.6	2.7
	22.5	3.4	2.6	3.5	2.6	3.8	2.6	3.9	2.8	4.0	2.8	4.3	2.7	4.6	2.7
	25.0	3.4	2.6	3.5	2.6	3.8	2.6	3.9	2.8	4.0	2.8	4.2	2.7	4.5	2.7
	27.5	3.4	2.6	3.5	2.6	3.7	2.6	3.8	2.7	3.9	2.7	4.1	2.7	4.4	2.6
	30.0	3.3	2.5	3.4	2.6	3.6	2.6	3.7	2.7	3.8	2.7	4.1	2.7	4.3	2.6
	32.5	3.3	2.5	3.4	2.6	3.6	2.5	3.7	2.7	3.8	2.7	4.0	2.6	4.2	2.6
	35.0	3.2	2.5	3.3	2.5	3.5	2.5	3.6	2.7	3.7	2.6	3.9	2.6	4.1	2.6
	37.5	3.2	2.4	3.3	2.5	3.4	2.5	3.5	2.6	3.6	2.6	3.8	2.6	4.0	2.5
	40.0	3.1	2.4	3.2	2.5	3.4	2.5	3.5	2.6	3.6	2.6	3.7	2.5	3.9	2.5
43.0	3.0	2.4	3.1	2.4	3.3	2.4	3.4	2.6	3.5	2.5	3.6	2.5	3.8	2.5	
40 (4.5)	20.0	4.3	3.1	4.4	3.2	4.7	3.2	4.9	3.4	5.0	3.4	5.3	3.3	5.7	3.3
	22.5	4.3	3.1	4.4	3.2	4.7	3.2	4.9	3.4	5.0	3.4	5.3	3.3	5.7	3.3
	25.0	4.3	3.1	4.4	3.2	4.7	3.2	4.9	3.4	5.0	3.4	5.3	3.3	5.6	3.3
	27.5	4.3	3.1	4.4	3.2	4.6	3.2	4.8	3.4	4.9	3.3	5.2	3.3	5.5	3.2
	30.0	4.2	3.1	4.3	3.2	4.6	3.1	4.7	3.3	4.8	3.3	5.1	3.2	5.4	3.2
	32.5	4.1	3.1	4.2	3.1	4.5	3.1	4.6	3.3	4.7	3.3	5.0	3.2	5.3	3.2
	35.0	4.0	3.0	4.1	3.1	4.4	3.1	4.5	3.2	4.6	3.2	4.9	3.2	5.2	3.1
	37.5	4.0	3.0	4.1	3.1	4.3	3.0	4.4	3.2	4.5	3.2	4.8	3.1	5.0	3.1
	40.0	3.9	2.9	4.0	3.0	4.2	3.0	4.3	3.2	4.4	3.1	4.7	3.1	4.9	3.0
43.0	3.8	2.9	3.9	3.0	4.1	2.9	4.2	3.1	4.3	3.1	4.5	3.0	4.8	3.0	

kcal/h=kW x 860 , BTU/h = kW x 3,412

3. Cooling [Ceiling cassette (1-way flow type)]

3-2. Cooling capacity with PUHY-RP300-400Y(S)JM,PURY-RP300YJM

PMFY-P-VBM-E

CA:Capacity(kW) , SHC:Sensible Heat Capacity(kW)

Model size (Rated kW)	Outdoor air temp. °C D.B.	Indoor air temp.													
		21.5°C D.B. 15°C W.B.		23°C D.B. 16°C W.B.		25°C D.B. 18°C W.B.		27°C D.B. 19°C W.B.		28°C D.B. 20°C W.B.		30°C D.B. 22°C W.B.		32°C D.B. 24°C W.B.	
		CA	SHC	CA	SHC	CA	SHC	CA	SHC	CA	SHC	CA	SHC	CA	SHC
20 (2.2)	20.0	2.1	1.8	2.2	1.9	2.4	1.9	2.5	2.0	2.5	2.0	2.7	2.0	2.9	2.0
	22.5	2.1	1.8	2.2	1.9	2.3	1.9	2.4	2.0	2.5	2.0	2.6	2.0	2.8	2.0
	25.0	2.1	1.8	2.2	1.9	2.3	1.9	2.4	2.0	2.4	2.0	2.6	2.0	2.8	1.9
	27.5	2.1	1.8	2.1	1.9	2.3	1.8	2.3	2.0	2.4	2.0	2.5	1.9	2.7	1.9
	30.0	2.0	1.8	2.1	1.8	2.2	1.8	2.3	2.0	2.4	2.0	2.5	1.9	2.6	1.9
	32.5	2.0	1.8	2.0	1.8	2.2	1.8	2.2	1.9	2.3	1.9	2.4	1.9	2.6	1.9
	35.0	2.0	1.8	2.0	1.8	2.1	1.8	2.2	1.9	2.3	1.9	2.4	1.9	2.5	1.9
	37.5	1.9	1.7	2.0	1.8	2.1	1.8	2.1	1.9	2.2	1.9	2.3	1.9	2.5	1.9
	40.0	1.9	1.7	1.9	1.8	2.0	1.8	2.1	1.9	2.2	1.9	2.3	1.9	2.4	1.8
43.0	1.9	1.7	1.9	1.7	2.0	1.7	2.0	1.9	2.1	1.9	2.2	1.8	2.4	1.8	
25 (2.8)	20.0	2.7	2.2	2.8	2.3	3.0	2.3	3.1	2.5	3.2	2.5	3.4	2.4	3.6	2.4
	22.5	2.7	2.2	2.8	2.3	3.0	2.3	3.1	2.5	3.2	2.5	3.4	2.4	3.6	2.4
	25.0	2.7	2.2	2.7	2.3	2.9	2.3	3.0	2.4	3.1	2.4	3.3	2.4	3.5	2.4
	27.5	2.6	2.2	2.7	2.3	2.9	2.3	3.0	2.4	3.1	2.4	3.2	2.4	3.4	2.3
	30.0	2.6	2.2	2.6	2.3	2.8	2.2	2.9	2.4	3.0	2.4	3.2	2.4	3.4	2.3
	32.5	2.5	2.2	2.6	2.2	2.8	2.2	2.8	2.4	2.9	2.4	3.1	2.3	3.3	2.3
	35.0	2.5	2.1	2.5	2.2	2.7	2.2	2.8	2.4	2.9	2.3	3.0	2.3	3.2	2.3
	37.5	2.5	2.1	2.5	2.2	2.6	2.2	2.7	2.3	2.8	2.3	3.0	2.3	3.2	2.3
	40.0	2.4	2.1	2.4	2.2	2.6	2.1	2.7	2.3	2.8	2.3	2.9	2.3	3.1	2.2
43.0	2.4	2.1	2.4	2.1	2.5	2.1	2.6	2.3	2.7	2.3	2.8	2.2	3.0	2.2	
32 (3.6)	20.0	3.5	2.6	3.6	2.7	3.9	2.7	4.0	2.8	4.2	2.8	4.4	2.8	4.7	2.8
	22.5	3.5	2.6	3.6	2.7	3.8	2.7	4.0	2.8	4.1	2.8	4.3	2.8	4.6	2.7
	25.0	3.4	2.6	3.5	2.6	3.8	2.6	3.9	2.8	4.0	2.8	4.2	2.7	4.5	2.7
	27.5	3.4	2.5	3.5	2.6	3.7	2.6	3.8	2.7	3.9	2.7	4.2	2.7	4.4	2.7
	30.0	3.3	2.5	3.4	2.6	3.6	2.6	3.7	2.7	3.8	2.7	4.1	2.7	4.3	2.6
	32.5	3.3	2.5	3.3	2.5	3.5	2.5	3.7	2.7	3.8	2.7	4.0	2.6	4.2	2.6
	35.0	3.2	2.5	3.3	2.5	3.5	2.5	3.6	2.7	3.7	2.6	3.9	2.6	4.2	2.6
	37.5	3.2	2.4	3.2	2.5	3.4	2.5	3.5	2.6	3.6	2.6	3.8	2.6	4.1	2.5
	40.0	3.1	2.4	3.1	2.5	3.3	2.4	3.4	2.6	3.5	2.6	3.8	2.5	4.0	2.5
43.0	3.0	2.4	3.0	2.4	3.2	2.4	3.3	2.5	3.4	2.5	3.7	2.5	3.9	2.5	
40 (4.5)	20.0	4.4	3.2	4.5	3.3	4.9	3.3	5.0	3.5	5.2	3.5	5.5	3.4	5.8	3.4
	22.5	4.4	3.2	4.5	3.3	4.8	3.3	4.9	3.4	5.1	3.4	5.4	3.4	5.7	3.3
	25.0	4.3	3.2	4.4	3.2	4.7	3.2	4.9	3.4	5.0	3.4	5.3	3.3	5.6	3.3
	27.5	4.2	3.1	4.3	3.2	4.6	3.2	4.8	3.4	4.9	3.3	5.2	3.3	5.5	3.2
	30.0	4.1	3.1	4.2	3.2	4.5	3.1	4.7	3.3	4.8	3.3	5.1	3.3	5.4	3.2
	32.5	4.1	3.0	4.2	3.1	4.4	3.1	4.6	3.3	4.7	3.3	5.0	3.2	5.3	3.2
	35.0	4.0	3.0	4.1	3.1	4.3	3.0	4.5	3.2	4.6	3.2	4.9	3.2	5.2	3.1
	37.5	3.9	3.0	4.0	3.0	4.2	3.0	4.4	3.2	4.5	3.2	4.8	3.1	5.1	3.1
	40.0	3.9	2.9	3.9	3.0	4.2	3.0	4.3	3.2	4.4	3.1	4.7	3.1	5.0	3.0
43.0	3.8	2.9	3.8	2.9	4.0	2.9	4.2	3.1	4.3	3.1	4.6	3.0	4.8	3.0	

kcal/h=kW x 860 , BTU/h = kW x 3,412

3. Cooling [Ceiling cassette (1-way flow type)]

3-3. Cooling capacity with PUHY-RP450-650YSJM

PMFY-P-VBM-E

CA:Capacity(kW) , SHC:Sensible Heat Capacity(kW)

Model size (Rated kW)	Outdoor air temp. °C D.B.	Indoor air temp.													
		21.5°C D.B. 15°C W.B.		23°C D.B. 16°C W.B.		25°C D.B. 18°C W.B.		27°C D.B. 19°C W.B.		28°C D.B. 20°C W.B.		30°C D.B. 22°C W.B.		32°C D.B. 24°C W.B.	
		CA	SHC	CA	SHC	CA	SHC	CA	SHC	CA	SHC	CA	SHC	CA	SHC
20 (2.2)	20.0	2.1	1.8	2.1	1.9	2.3	1.9	2.4	2.0	2.4	2.0	2.6	2.0	2.8	1.9
	22.5	2.1	1.8	2.1	1.9	2.3	1.8	2.3	2.0	2.4	2.0	2.6	2.0	2.7	1.9
	25.0	2.0	1.8	2.1	1.8	2.2	1.8	2.3	2.0	2.4	2.0	2.5	1.9	2.7	1.9
	27.5	2.0	1.8	2.1	1.8	2.2	1.8	2.3	2.0	2.4	2.0	2.5	1.9	2.7	1.9
	30.0	2.0	1.8	2.0	1.8	2.2	1.8	2.3	2.0	2.3	2.0	2.5	1.9	2.7	1.9
	32.5	2.0	1.8	2.0	1.8	2.2	1.8	2.2	1.9	2.3	1.9	2.5	1.9	2.6	1.9
	35.0	2.0	1.7	2.0	1.8	2.1	1.8	2.2	1.9	2.3	1.9	2.5	1.9	2.6	1.9
	37.5	1.9	1.7	2.0	1.8	2.1	1.8	2.2	1.9	2.3	1.9	2.4	1.9	2.6	1.9
	40.0	1.9	1.7	1.9	1.8	2.1	1.8	2.2	1.9	2.2	1.9	2.4	1.9	2.6	1.9
43.0	1.9	1.7	1.9	1.8	2.1	1.8	2.1	1.9	2.2	1.9	2.4	1.9	2.5	1.9	
25 (2.8)	20.0	2.6	2.2	2.7	2.3	2.9	2.3	3.0	2.4	3.1	2.4	3.3	2.4	3.5	2.4
	22.5	2.6	2.2	2.7	2.3	2.9	2.3	3.0	2.4	3.1	2.4	3.3	2.4	3.5	2.4
	25.0	2.6	2.2	2.7	2.3	2.9	2.3	2.9	2.4	3.0	2.4	3.2	2.4	3.5	2.4
	27.5	2.6	2.2	2.6	2.3	2.8	2.2	2.9	2.4	3.0	2.4	3.2	2.4	3.4	2.3
	30.0	2.5	2.2	2.6	2.2	2.8	2.2	2.9	2.4	3.0	2.4	3.2	2.4	3.4	2.3
	32.5	2.5	2.2	2.6	2.2	2.8	2.2	2.9	2.4	3.0	2.4	3.2	2.3	3.4	2.3
	35.0	2.5	2.1	2.5	2.2	2.7	2.2	2.8	2.4	2.9	2.4	3.1	2.3	3.3	2.3
	37.5	2.5	2.1	2.5	2.2	2.7	2.2	2.8	2.4	2.9	2.3	3.1	2.3	3.3	2.3
	40.0	2.4	2.1	2.5	2.2	2.7	2.2	2.8	2.3	2.9	2.3	3.1	2.3	3.3	2.3
43.0	2.4	2.1	2.4	2.2	2.6	2.2	2.7	2.3	2.8	2.3	3.0	2.3	3.2	2.3	
32 (3.6)	20.0	3.4	2.6	3.5	2.6	3.7	2.6	3.9	2.8	4.0	2.8	4.3	2.7	4.5	2.7
	22.5	3.4	2.5	3.5	2.6	3.7	2.6	3.8	2.8	4.0	2.7	4.2	2.7	4.5	2.7
	25.0	3.3	2.5	3.4	2.6	3.7	2.6	3.8	2.7	3.9	2.7	4.2	2.7	4.4	2.7
	27.5	3.3	2.5	3.4	2.6	3.6	2.6	3.8	2.7	3.9	2.7	4.1	2.7	4.4	2.7
	30.0	3.3	2.5	3.3	2.6	3.6	2.5	3.7	2.7	3.8	2.7	4.1	2.7	4.4	2.6
	32.5	3.2	2.5	3.3	2.5	3.5	2.5	3.7	2.7	3.8	2.7	4.1	2.7	4.3	2.6
	35.0	3.2	2.5	3.3	2.5	3.5	2.5	3.6	2.7	3.8	2.7	4.0	2.6	4.3	2.6
	37.5	3.2	2.4	3.2	2.5	3.5	2.5	3.6	2.7	3.7	2.6	4.0	2.6	4.2	2.6
	40.0	3.1	2.4	3.2	2.5	3.4	2.5	3.5	2.6	3.7	2.6	3.9	2.6	4.2	2.6
43.0	3.1	2.4	3.1	2.5	3.4	2.5	3.5	2.6	3.6	2.6	3.9	2.6	4.2	2.6	
40 (4.5)	20.0	4.3	3.1	4.4	3.2	4.7	3.2	4.8	3.4	5.0	3.4	5.3	3.3	5.7	3.3
	22.5	4.2	3.1	4.3	3.2	4.6	3.2	4.8	3.4	4.9	3.4	5.3	3.3	5.6	3.3
	25.0	4.2	3.1	4.3	3.2	4.6	3.2	4.7	3.3	4.9	3.3	5.2	3.3	5.6	3.3
	27.5	4.1	3.1	4.2	3.1	4.5	3.1	4.7	3.3	4.8	3.3	5.2	3.3	5.5	3.2
	30.0	4.1	3.0	4.2	3.1	4.5	3.1	4.6	3.3	4.8	3.3	5.1	3.3	5.5	3.2
	32.5	4.0	3.0	4.1	3.1	4.4	3.1	4.6	3.3	4.7	3.3	5.1	3.2	5.4	3.2
	35.0	4.0	3.0	4.1	3.1	4.4	3.1	4.5	3.2	4.7	3.2	5.0	3.2	5.4	3.2
	37.5	4.0	3.0	4.0	3.0	4.3	3.0	4.5	3.2	4.6	3.2	5.0	3.2	5.3	3.2
	40.0	3.9	3.0	4.0	3.0	4.3	3.0	4.4	3.2	4.6	3.2	4.9	3.2	5.3	3.2
43.0	3.9	2.9	3.9	3.0	4.2	3.0	4.4	3.2	4.5	3.2	4.9	3.2	5.2	3.1	

kcal/h=kW x 860 , BTU/h = kW x 3,412

3. Cooling [Ceiling cassette (1-way flow type)]

3-4. Cooling capacity with PUHY-RP700-800YSJM

PMFY-P-VBM-E

CA:Capacity(kW) , SHC:Sensible Heat Capacity(kW)

Model size (Rated kW)	Outdoor air temp. °C D.B.	Indoor air temp.													
		21.5°C D.B. 15°C W.B.		23°C D.B. 16°C W.B.		25°C D.B. 18°C W.B.		27°C D.B. 19°C W.B.		28°C D.B. 20°C W.B.		30°C D.B. 22°C W.B.		32°C D.B. 24°C W.B.	
		CA	SHC	CA	SHC	CA	SHC	CA	SHC	CA	SHC	CA	SHC	CA	SHC
20 (2.2)	20.0	2.1	1.8	2.2	1.9	2.4	1.9	2.4	2.0	2.5	2.0	2.7	2.0	2.9	2.0
	22.5	2.1	1.8	2.2	1.9	2.3	1.9	2.4	2.0	2.5	2.0	2.6	2.0	2.8	2.0
	25.0	2.1	1.8	2.1	1.9	2.3	1.9	2.4	2.0	2.4	2.0	2.6	2.0	2.8	1.9
	27.5	2.0	1.8	2.1	1.8	2.2	1.8	2.3	2.0	2.4	2.0	2.6	2.0	2.7	1.9
	30.0	2.0	1.8	2.0	1.8	2.2	1.8	2.3	2.0	2.4	2.0	2.5	1.9	2.7	1.9
	32.5	1.9	1.7	2.0	1.8	2.2	1.8	2.2	1.9	2.3	1.9	2.5	1.9	2.6	1.9
	35.0	1.9	1.7	2.0	1.8	2.1	1.8	2.2	1.9	2.3	1.9	2.4	1.9	2.6	1.9
	37.5	1.9	1.7	1.9	1.8	2.1	1.8	2.1	1.9	2.2	1.9	2.4	1.9	2.5	1.9
	40.0	1.8	1.7	1.9	1.8	2.0	1.8	2.1	1.9	2.2	1.9	2.3	1.9	2.5	1.8
43.0	1.8	1.7	1.8	1.7	2.0	1.7	2.1	1.9	2.1	1.9	2.3	1.9	2.4	1.8	
25 (2.8)	20.0	2.7	2.2	2.8	2.3	3.0	2.3	3.1	2.5	3.2	2.5	3.4	2.4	3.7	2.4
	22.5	2.7	2.2	2.8	2.3	3.0	2.3	3.1	2.5	3.2	2.5	3.4	2.4	3.6	2.4
	25.0	2.6	2.2	2.7	2.3	2.9	2.3	3.0	2.4	3.1	2.4	3.3	2.4	3.5	2.4
	27.5	2.6	2.2	2.7	2.3	2.9	2.3	3.0	2.4	3.1	2.4	3.3	2.4	3.5	2.4
	30.0	2.5	2.2	2.6	2.2	2.8	2.2	2.9	2.4	3.0	2.4	3.2	2.4	3.4	2.3
	32.5	2.5	2.1	2.6	2.2	2.7	2.2	2.8	2.4	2.9	2.4	3.1	2.3	3.3	2.3
	35.0	2.4	2.1	2.5	2.2	2.7	2.2	2.8	2.4	2.9	2.3	3.1	2.3	3.3	2.3
	37.5	2.4	2.1	2.5	2.2	2.6	2.2	2.7	2.3	2.8	2.3	3.0	2.3	3.2	2.3
	40.0	2.3	2.1	2.4	2.2	2.6	2.1	2.7	2.3	2.8	2.3	3.0	2.3	3.1	2.3
43.0	2.3	2.1	2.4	2.1	2.5	2.1	2.6	2.3	2.7	2.3	2.9	2.3	3.1	2.2	
32 (3.6)	20.0	3.5	2.6	3.6	2.7	3.9	2.7	4.0	2.8	4.1	2.8	4.4	2.8	4.7	2.8
	22.5	3.4	2.6	3.5	2.6	3.8	2.6	3.9	2.8	4.1	2.8	4.3	2.8	4.6	2.7
	25.0	3.4	2.5	3.5	2.6	3.7	2.6	3.9	2.8	4.0	2.8	4.3	2.7	4.5	2.7
	27.5	3.3	2.5	3.4	2.6	3.7	2.6	3.8	2.7	3.9	2.7	4.2	2.7	4.5	2.7
	30.0	3.2	2.5	3.4	2.6	3.6	2.5	3.7	2.7	3.9	2.7	4.1	2.7	4.4	2.6
	32.5	3.2	2.4	3.3	2.5	3.5	2.5	3.7	2.7	3.8	2.7	4.0	2.6	4.3	2.6
	35.0	3.1	2.4	3.2	2.5	3.5	2.5	3.6	2.7	3.7	2.6	4.0	2.6	4.2	2.6
	37.5	3.1	2.4	3.2	2.5	3.4	2.5	3.5	2.6	3.6	2.6	3.9	2.6	4.1	2.6
	40.0	3.0	2.4	3.1	2.4	3.3	2.4	3.4	2.6	3.6	2.6	3.8	2.6	4.0	2.5
43.0	2.9	2.3	3.0	2.4	3.2	2.4	3.4	2.6	3.5	2.5	3.7	2.5	3.9	2.5	
40 (4.5)	20.0	4.3	3.2	4.5	3.3	4.8	3.3	5.0	3.5	5.2	3.5	5.5	3.4	5.9	3.4
	22.5	4.3	3.1	4.4	3.2	4.7	3.2	4.9	3.4	5.1	3.4	5.4	3.4	5.8	3.3
	25.0	4.2	3.1	4.3	3.2	4.7	3.2	4.8	3.4	5.0	3.4	5.3	3.3	5.7	3.3
	27.5	4.1	3.1	4.3	3.2	4.6	3.2	4.7	3.3	4.9	3.3	5.2	3.3	5.6	3.3
	30.0	4.1	3.0	4.2	3.1	4.5	3.1	4.7	3.3	4.8	3.3	5.1	3.3	5.5	3.2
	32.5	4.0	3.0	4.1	3.1	4.4	3.1	4.6	3.3	4.7	3.3	5.0	3.2	5.4	3.2
	35.0	3.9	3.0	4.0	3.1	4.3	3.0	4.5	3.2	4.6	3.2	4.9	3.2	5.3	3.1
	37.5	3.8	2.9	4.0	3.0	4.2	3.0	4.4	3.2	4.5	3.2	4.8	3.2	5.2	3.1
	40.0	3.8	2.9	3.9	3.0	4.2	3.0	4.3	3.2	4.5	3.1	4.8	3.1	5.1	3.1
43.0	3.7	2.8	3.8	2.9	4.1	2.9	4.2	3.1	4.3	3.1	4.6	3.1	4.9	3.0	

kcal/h=kW x 860 , BTU/h = kW x 3,412

3. Cooling [Ceiling cassette (1-way flow type)]

3-5. Cooling capacity with PUHY-RP850-900YSJM

PMFY-P-VBM-E

CA:Capacity(kW) , SHC:Sensible Heat Capacity(kW)

Model size (Rated kW)	Outdoor air temp. °C D.B.	Indoor air temp.													
		21.5°C D.B. 15°C W.B.		23°C D.B. 16°C W.B.		25°C D.B. 18°C W.B.		27°C D.B. 19°C W.B.		28°C D.B. 20°C W.B.		30°C D.B. 22°C W.B.		32°C D.B. 24°C W.B.	
		CA	SHC	CA	SHC	CA	SHC	CA	SHC	CA	SHC	CA	SHC	CA	SHC
20 (2.2)	20.0	2.1	1.8	2.1	1.9	2.3	1.9	2.4	2.0	2.4	2.0	2.6	2.0	2.8	1.9
	22.5	2.1	1.8	2.1	1.9	2.3	1.8	2.3	2.0	2.4	2.0	2.6	2.0	2.7	1.9
	25.0	2.0	1.8	2.1	1.8	2.2	1.8	2.3	2.0	2.4	2.0	2.5	1.9	2.7	1.9
	27.5	2.0	1.8	2.1	1.8	2.2	1.8	2.3	2.0	2.4	2.0	2.5	1.9	2.7	1.9
	30.0	2.0	1.8	2.0	1.8	2.2	1.8	2.3	2.0	2.3	2.0	2.5	1.9	2.7	1.9
	32.5	2.0	1.8	2.0	1.8	2.2	1.8	2.2	1.9	2.3	1.9	2.5	1.9	2.6	1.9
	35.0	2.0	1.7	2.0	1.8	2.1	1.8	2.2	1.9	2.3	1.9	2.5	1.9	2.6	1.9
	37.5	1.9	1.7	2.0	1.8	2.1	1.8	2.2	1.9	2.3	1.9	2.4	1.9	2.6	1.9
	40.0	1.9	1.7	1.9	1.8	2.1	1.8	2.2	1.9	2.2	1.9	2.4	1.9	2.6	1.9
43.0	1.9	1.7	1.9	1.8	2.1	1.8	2.1	1.9	2.2	1.9	2.4	1.9	2.5	1.9	
25 (2.8)	20.0	2.6	2.2	2.7	2.3	2.9	2.3	3.0	2.4	3.1	2.4	3.3	2.4	3.5	2.4
	22.5	2.6	2.2	2.7	2.3	2.9	2.3	3.0	2.4	3.1	2.4	3.3	2.4	3.5	2.4
	25.0	2.6	2.2	2.7	2.3	2.9	2.3	2.9	2.4	3.0	2.4	3.2	2.4	3.5	2.4
	27.5	2.6	2.2	2.6	2.3	2.8	2.2	2.9	2.4	3.0	2.4	3.2	2.4	3.4	2.3
	30.0	2.5	2.2	2.6	2.2	2.8	2.2	2.9	2.4	3.0	2.4	3.2	2.4	3.4	2.3
	32.5	2.5	2.2	2.6	2.2	2.8	2.2	2.9	2.4	3.0	2.4	3.2	2.3	3.4	2.3
	35.0	2.5	2.1	2.5	2.2	2.7	2.2	2.8	2.4	2.9	2.4	3.1	2.3	3.3	2.3
	37.5	2.5	2.1	2.5	2.2	2.7	2.2	2.8	2.4	2.9	2.3	3.1	2.3	3.3	2.3
	40.0	2.4	2.1	2.5	2.2	2.7	2.2	2.8	2.3	2.9	2.3	3.1	2.3	3.3	2.3
43.0	2.4	2.1	2.4	2.2	2.6	2.2	2.7	2.3	2.8	2.3	3.0	2.3	3.2	2.3	
32 (3.6)	20.0	3.4	2.6	3.5	2.6	3.7	2.6	3.9	2.8	4.0	2.8	4.3	2.7	4.5	2.7
	22.5	3.4	2.5	3.5	2.6	3.7	2.6	3.8	2.8	4.0	2.7	4.2	2.7	4.5	2.7
	25.0	3.3	2.5	3.4	2.6	3.7	2.6	3.8	2.7	3.9	2.7	4.2	2.7	4.4	2.7
	27.5	3.3	2.5	3.4	2.6	3.6	2.6	3.8	2.7	3.9	2.7	4.1	2.7	4.4	2.7
	30.0	3.3	2.5	3.3	2.6	3.6	2.5	3.7	2.7	3.8	2.7	4.1	2.7	4.4	2.6
	32.5	3.2	2.5	3.3	2.5	3.5	2.5	3.7	2.7	3.8	2.7	4.1	2.7	4.3	2.6
	35.0	3.2	2.5	3.3	2.5	3.5	2.5	3.6	2.7	3.8	2.7	4.0	2.6	4.3	2.6
	37.5	3.2	2.4	3.2	2.5	3.5	2.5	3.6	2.7	3.7	2.6	4.0	2.6	4.2	2.6
	40.0	3.1	2.4	3.2	2.5	3.4	2.5	3.5	2.6	3.7	2.6	3.9	2.6	4.2	2.6
43.0	3.1	2.4	3.1	2.5	3.4	2.5	3.5	2.6	3.6	2.6	3.9	2.6	4.2	2.6	
40 (4.5)	20.0	4.3	3.1	4.4	3.2	4.7	3.2	4.8	3.4	5.0	3.4	5.3	3.3	5.7	3.3
	22.5	4.2	3.1	4.3	3.2	4.6	3.2	4.8	3.4	4.9	3.4	5.3	3.3	5.6	3.3
	25.0	4.2	3.1	4.3	3.2	4.6	3.2	4.7	3.3	4.9	3.3	5.2	3.3	5.6	3.3
	27.5	4.1	3.1	4.2	3.1	4.5	3.1	4.7	3.3	4.8	3.3	5.2	3.3	5.5	3.2
	30.0	4.1	3.0	4.2	3.1	4.5	3.1	4.6	3.3	4.8	3.3	5.1	3.3	5.5	3.2
	32.5	4.0	3.0	4.1	3.1	4.4	3.1	4.6	3.3	4.7	3.3	5.1	3.2	5.4	3.2
	35.0	4.0	3.0	4.1	3.1	4.4	3.1	4.5	3.2	4.7	3.2	5.0	3.2	5.4	3.2
	37.5	4.0	3.0	4.0	3.0	4.3	3.0	4.5	3.2	4.6	3.2	5.0	3.2	5.3	3.2
	40.0	3.9	3.0	4.0	3.0	4.3	3.0	4.4	3.2	4.6	3.2	4.9	3.2	5.3	3.2
43.0	3.9	2.9	3.9	3.0	4.2	3.0	4.4	3.2	4.5	3.2	4.9	3.2	5.2	3.1	

kcal/h=kW x 860 , BTU/h = kW x 3,412

4. Cooling [Ceiling cassette (2-way flow type)]

4-1. Cooling capacity with PUHY,PURY-RP200-250YJM

PLFY-P-VLMD-E

CA:Capacity(kW) , SHC:Sensible Heat Capacity(kW)

Model size (Rated kW)	Outdoor air temp. °C D.B.	Indoor air temp.													
		21.5°C D.B. 15°C W.B.		23°C D.B. 16°C W.B.		25°C D.B. 18°C W.B.		27°C D.B. 19°C W.B.		28°C D.B. 20°C W.B.		30°C D.B. 22°C W.B.		32°C D.B. 24°C W.B.	
		CA	SHC	CA	SHC	CA	SHC	CA	SHC	CA	SHC	CA	SHC	CA	SHC
20 (2.2)	20.0	2.1	1.9	2.2	1.9	2.3	1.9	2.4	2.1	2.5	2.1	2.6	2.0	2.8	2.0
	22.5	2.1	1.9	2.2	1.9	2.3	1.9	2.4	2.1	2.5	2.1	2.6	2.0	2.8	2.0
	25.0	2.1	1.9	2.2	1.9	2.3	1.9	2.4	2.1	2.4	2.1	2.6	2.0	2.7	2.0
	27.5	2.1	1.9	2.1	1.9	2.3	1.9	2.3	2.1	2.4	2.0	2.5	2.0	2.7	2.0
	30.0	2.0	1.8	2.1	1.9	2.2	1.9	2.3	2.0	2.3	2.0	2.5	2.0	2.6	2.0
	32.5	2.0	1.8	2.1	1.9	2.2	1.9	2.2	2.0	2.3	2.0	2.4	2.0	2.6	1.9
	35.0	2.0	1.8	2.0	1.9	2.1	1.9	2.2	2.0	2.3	2.0	2.4	2.0	2.5	1.9
	37.5	1.9	1.8	2.0	1.9	2.1	1.8	2.2	2.0	2.2	2.0	2.3	1.9	2.5	1.9
	40.0	1.9	1.8	2.0	1.8	2.1	1.8	2.1	2.0	2.2	2.0	2.3	1.9	2.4	1.9
43.0	1.8	1.8	1.9	1.8	2.0	1.8	2.1	2.0	2.1	1.9	2.2	1.9	2.3	1.9	
25 (2.8)	20.0	2.7	2.1	2.8	2.2	2.9	2.2	3.0	2.3	3.1	2.3	3.3	2.3	3.5	2.3
	22.5	2.7	2.1	2.8	2.2	2.9	2.2	3.0	2.3	3.1	2.3	3.3	2.3	3.5	2.3
	25.0	2.7	2.1	2.8	2.2	2.9	2.2	3.0	2.3	3.1	2.3	3.3	2.3	3.5	2.2
	27.5	2.7	2.1	2.7	2.2	2.9	2.2	3.0	2.3	3.0	2.3	3.2	2.3	3.4	2.2
	30.0	2.6	2.1	2.7	2.2	2.8	2.1	2.9	2.3	3.0	2.3	3.2	2.2	3.3	2.2
	32.5	2.6	2.1	2.6	2.1	2.8	2.1	2.9	2.3	2.9	2.2	3.1	2.2	3.3	2.2
	35.0	2.5	2.1	2.6	2.1	2.7	2.1	2.8	2.2	2.9	2.2	3.0	2.2	3.2	2.2
	37.5	2.5	2.0	2.5	2.1	2.7	2.1	2.8	2.2	2.8	2.2	3.0	2.2	3.1	2.1
	40.0	2.4	2.0	2.5	2.1	2.6	2.1	2.7	2.2	2.8	2.2	2.9	2.1	3.1	2.1
43.0	2.4	2.0	2.4	2.1	2.6	2.0	2.6	2.2	2.7	2.2	2.8	2.1	3.0	2.1	
32 (3.6)	20.0	3.4	2.6	3.5	2.6	3.8	2.6	3.9	2.8	4.0	2.8	4.3	2.7	4.6	2.7
	22.5	3.4	2.6	3.5	2.6	3.8	2.6	3.9	2.8	4.0	2.8	4.3	2.7	4.6	2.7
	25.0	3.4	2.6	3.5	2.6	3.8	2.6	3.9	2.8	4.0	2.7	4.2	2.7	4.5	2.7
	27.5	3.4	2.5	3.5	2.6	3.7	2.6	3.8	2.7	3.9	2.7	4.1	2.7	4.4	2.6
	30.0	3.3	2.5	3.4	2.6	3.6	2.6	3.7	2.7	3.8	2.7	4.1	2.6	4.3	2.6
	32.5	3.3	2.5	3.4	2.6	3.6	2.5	3.7	2.7	3.8	2.7	4.0	2.6	4.2	2.6
	35.0	3.2	2.5	3.3	2.5	3.5	2.5	3.6	2.6	3.7	2.6	3.9	2.6	4.1	2.5
	37.5	3.2	2.4	3.3	2.5	3.4	2.5	3.5	2.6	3.6	2.6	3.8	2.5	4.0	2.5
	40.0	3.1	2.4	3.2	2.5	3.4	2.4	3.5	2.6	3.6	2.6	3.7	2.5	3.9	2.5
43.0	3.0	2.4	3.1	2.4	3.3	2.4	3.4	2.6	3.5	2.5	3.6	2.5	3.8	2.4	
40 (4.5)	20.0	4.3	3.0	4.4	3.1	4.7	3.1	4.9	3.2	5.0	3.2	5.3	3.1	5.7	3.1
	22.5	4.3	3.0	4.4	3.1	4.7	3.1	4.9	3.2	5.0	3.2	5.3	3.1	5.7	3.1
	25.0	4.3	3.0	4.4	3.1	4.7	3.1	4.9	3.2	5.0	3.2	5.3	3.1	5.6	3.1
	27.5	4.3	3.0	4.4	3.1	4.6	3.0	4.8	3.2	4.9	3.1	5.2	3.1	5.5	3.0
	30.0	4.2	2.9	4.3	3.0	4.6	3.0	4.7	3.1	4.8	3.1	5.1	3.0	5.4	3.0
	32.5	4.1	2.9	4.2	3.0	4.5	2.9	4.6	3.1	4.7	3.1	5.0	3.0	5.3	3.0
	35.0	4.0	2.9	4.1	2.9	4.4	2.9	4.5	3.0	4.6	3.0	4.9	3.0	5.2	2.9
	37.5	4.0	2.8	4.1	2.9	4.3	2.9	4.4	3.0	4.5	3.0	4.8	2.9	5.0	2.9
	40.0	3.9	2.8	4.0	2.9	4.2	2.8	4.3	3.0	4.4	2.9	4.7	2.9	4.9	2.8
43.0	3.8	2.7	3.9	2.8	4.1	2.8	4.2	2.9	4.3	2.9	4.5	2.8	4.8	2.8	
50 (5.6)	20.0	5.3	3.8	5.5	3.9	5.9	3.9	6.1	4.1	6.2	4.1	6.6	4.0	7.1	4.0
	22.5	5.3	3.8	5.5	3.9	5.9	3.9	6.1	4.1	6.2	4.1	6.6	4.0	7.1	4.0
	25.0	5.3	3.8	5.5	3.9	5.9	3.9	6.0	4.1	6.2	4.1	6.6	4.0	7.0	3.9
	27.5	5.3	3.8	5.5	3.9	5.8	3.9	5.9	4.1	6.1	4.0	6.4	4.0	6.8	3.9
	30.0	5.2	3.8	5.4	3.9	5.7	3.8	5.8	4.0	6.0	4.0	6.3	3.9	6.7	3.8
	32.5	5.1	3.7	5.3	3.8	5.6	3.8	5.7	4.0	5.9	3.9	6.2	3.9	6.6	3.8
	35.0	5.0	3.7	5.2	3.8	5.5	3.7	5.6	3.9	5.8	3.9	6.1	3.8	6.4	3.7
	37.5	4.9	3.6	5.1	3.7	5.4	3.7	5.5	3.9	5.6	3.8	5.9	3.8	6.3	3.7
	40.0	4.8	3.6	5.0	3.7	5.3	3.6	5.4	3.8	5.5	3.8	5.8	3.7	6.1	3.6
43.0	4.7	3.5	4.8	3.6	5.1	3.6	5.3	3.8	5.4	3.7	5.6	3.6	6.0	3.6	
63 (7.1)	20.0	6.7	4.7	7.0	4.9	7.5	4.8	7.7	5.1	7.9	5.1	8.4	5.0	9.0	4.9
	22.5	6.7	4.7	7.0	4.9	7.5	4.8	7.7	5.1	7.9	5.1	8.4	5.0	9.0	4.9
	25.0	6.7	4.7	7.0	4.9	7.5	4.8	7.7	5.1	7.9	5.0	8.3	4.9	8.8	4.9
	27.5	6.7	4.7	6.9	4.8	7.3	4.8	7.5	5.0	7.7	5.0	8.1	4.9	8.7	4.8
	30.0	6.6	4.7	6.8	4.8	7.2	4.7	7.4	4.9	7.6	4.9	8.0	4.8	8.5	4.7
	32.5	6.5	4.6	6.7	4.7	7.1	4.6	7.2	4.9	7.4	4.8	7.8	4.7	8.3	4.7
	35.0	6.4	4.5	6.5	4.6	6.9	4.6	7.1	4.8	7.3	4.8	7.7	4.7	8.1	4.6
	37.5	6.2	4.5	6.4	4.6	6.8	4.5	7.0	4.8	7.2	4.7	7.5	4.6	8.0	4.5
	40.0	6.1	4.4	6.3	4.5	6.7	4.5	6.8	4.7	7.0	4.7	7.4	4.6	7.8	4.5
43.0	6.0	4.3	6.1	4.4	6.5	4.4	6.7	4.6	6.9	4.6	7.2	4.5	7.6	4.4	
80 (9.0)	20.0	8.6	6.2	8.9	6.4	9.5	6.4	9.7	6.8	10.0	6.7	10.6	6.6	11.4	6.6
	22.5	8.6	6.2	8.9	6.4	9.5	6.4	9.7	6.8	10.0	6.7	10.6	6.6	11.4	6.6
	25.0	8.6	6.2	8.9	6.4	9.5	6.4	9.7	6.7	10.0	6.7	10.5	6.6	11.2	6.5
	27.5	8.5	6.2	8.8	6.4	9.3	6.3	9.5	6.7	9.8	6.6	10.3	6.5	11.0	6.4
	30.0	8.4	6.2	8.6	6.3	9.1	6.3	9.4	6.6	9.6	6.5	10.1	6.4	10.8	6.3
	32.5	8.2	6.1	8.5	6.2	8.9	6.2	9.2	6.5	9.4	6.5	9.9	6.3	10.5	6.3
	35.0	8.1	6.0	8.3	6.2	8.8	6.1	9.0	6.4	9.2	6.4	9.7	6.3	10.3	6.2
	37.5	7.9	5.9	8.1	6.1	8.6	6.0	8.8	6.4	9.1	6.3	9.5	6.2	10.1	6.1
	40.0	7.7	5.8	8.0	6.0	8.4	5.9	8.7	6.3	8.9	6.2	9.3	6.1	9.9	6.0
43.0	7.6	5.8	7.8	5.9	8.2	5.9	8.5	6.2	8.7	6.2	9.1	6.0	9.6	5.9	

kcal/h=kW x 860 , BTU/h = kW x 3,412

4. Cooling [Ceiling cassette (2-way flow type)]

PLFY-P-VLMD-E

CA:Capacity(kW) , SHC:Sensible Heat Capacity(kW)

Model size (Rated kW)	Outdoor air temp. °C D.B.	Indoor air temp.													
		21.5°C D.B. 15°C W.B.		23°C D.B. 16°C W.B.		25°C D.B. 18°C W.B.		27°C D.B. 19°C W.B.		28°C D.B. 20°C W.B.		30°C D.B. 22°C W.B.		32°C D.B. 24°C W.B.	
		CA	SHC	CA	SHC	CA	SHC	CA	SHC	CA	SHC	CA	SHC	CA	SHC
100 (11.2)	20.0	10.6	7.7	11.0	7.9	11.8	7.9	12.1	8.3	12.5	8.2	13.2	8.1	14.2	8.0
	22.5	10.6	7.7	11.0	7.9	11.8	7.9	12.1	8.3	12.5	8.2	13.2	8.1	14.2	8.0
	25.0	10.6	7.7	11.0	7.9	11.8	7.9	12.1	8.3	12.4	8.2	13.1	8.1	13.9	8.0
	27.5	10.6	7.7	10.9	7.9	11.6	7.8	11.9	8.2	12.2	8.1	12.9	8.0	13.7	7.9
	30.0	10.4	7.6	10.7	7.8	11.3	7.7	11.6	8.1	12.0	8.0	12.6	7.9	13.4	7.8
	32.5	10.2	7.5	10.5	7.7	11.1	7.6	11.4	8.0	11.7	7.9	12.4	7.8	13.1	7.7
	35.0	10.0	7.4	10.3	7.6	10.9	7.5	11.2	7.9	11.5	7.8	12.1	7.7	12.8	7.6
	37.5	9.8	7.3	10.1	7.5	10.7	7.4	11.0	7.8	11.3	7.7	11.9	7.6	12.6	7.5
	40.0	9.6	7.2	9.9	7.4	10.5	7.3	10.8	7.7	11.1	7.6	11.6	7.5	12.3	7.4
43.0	9.4	7.1	9.7	7.3	10.2	7.2	10.5	7.6	10.8	7.5	11.3	7.4	12.0	7.2	
125 (14.0)	20.0	13.3	9.8	13.8	10.1	14.7	10.0	15.2	10.6	15.6	10.5	16.6	10.4	17.7	10.2
	22.5	13.3	9.8	13.8	10.1	14.7	10.0	15.2	10.6	15.6	10.5	16.6	10.4	17.7	10.2
	25.0	13.3	9.8	13.8	10.1	14.7	10.0	15.1	10.5	15.5	10.4	16.4	10.3	17.4	10.1
	27.5	13.3	9.7	13.6	10.0	14.4	9.9	14.8	10.4	15.2	10.3	16.1	10.2	17.1	10.0
	30.0	13.0	9.6	13.4	9.9	14.2	9.8	14.6	10.3	14.9	10.2	15.8	10.0	16.7	9.9
	32.5	12.8	9.5	13.2	9.8	13.9	9.6	14.3	10.2	14.7	10.1	15.4	9.9	16.4	9.8
	35.0	12.5	9.4	12.9	9.6	13.7	9.5	14.0	10.1	14.4	10.0	15.1	9.8	16.0	9.7
	37.5	12.3	9.3	12.7	9.5	13.4	9.4	13.8	9.9	14.1	9.9	14.8	9.7	15.7	9.5
	40.0	12.1	9.1	12.4	9.4	13.1	9.3	13.5	9.8	13.8	9.7	14.5	9.6	15.4	9.4
43.0	11.8	9.0	12.1	9.3	12.8	9.1	13.2	9.7	13.5	9.6	14.1	9.4	15.0	9.3	

kcal/h=kW x 860 , BTU/h = kW x 3,412

4. Cooling [Ceiling cassette (2-way flow type)]

4-2. Cooling capacity with PUHY-RP300-400Y(S)JM,PURY-RP300YJM

PLFY-P-VLMD-E

CA:Capacity(kW) , SHC:Sensible Heat Capacity(kW)

Model size (Rated kW)	Outdoor air temp. °C D.B.	Indoor air temp.													
		21.5°C D.B. 15°C W.B.		23°C D.B. 16°C W.B.		25°C D.B. 18°C W.B.		27°C D.B. 19°C W.B.		28°C D.B. 20°C W.B.		30°C D.B. 22°C W.B.		32°C D.B. 24°C W.B.	
		CA	SHC	CA	SHC	CA	SHC	CA	SHC	CA	SHC	CA	SHC	CA	SHC
20 (2.2)	20.0	2.1	1.9	2.2	2.0	2.4	2.0	2.5	2.1	2.5	2.1	2.7	2.1	2.9	2.0
	22.5	2.1	1.9	2.2	2.0	2.3	1.9	2.4	2.1	2.5	2.1	2.6	2.1	2.8	2.0
	25.0	2.1	1.9	2.2	1.9	2.3	1.9	2.4	2.1	2.4	2.1	2.6	2.0	2.8	2.0
	27.5	2.1	1.9	2.1	1.9	2.3	1.9	2.3	2.1	2.4	2.0	2.5	2.0	2.7	2.0
	30.0	2.0	1.8	2.1	1.9	2.2	1.9	2.3	2.0	2.4	2.0	2.5	2.0	2.6	2.0
	32.5	2.0	1.8	2.0	1.9	2.2	1.9	2.2	2.0	2.3	2.0	2.4	2.0	2.6	2.0
	35.0	2.0	1.8	2.0	1.9	2.1	1.9	2.2	2.0	2.3	2.0	2.4	2.0	2.5	1.9
	37.5	1.9	1.8	2.0	1.8	2.1	1.8	2.1	2.0	2.2	2.0	2.3	1.9	2.5	1.9
	40.0	1.9	1.8	1.9	1.8	2.0	1.8	2.1	2.0	2.2	2.0	2.3	1.9	2.4	1.9
43.0	1.9	1.8	1.9	1.8	2.0	1.8	2.0	1.9	2.1	1.9	2.2	1.9	2.4	1.9	
25 (2.8)	20.0	2.7	2.2	2.8	2.2	3.0	2.2	3.1	2.4	3.2	2.4	3.4	2.3	3.6	2.3
	22.5	2.7	2.2	2.8	2.2	3.0	2.2	3.1	2.4	3.2	2.3	3.4	2.3	3.6	2.3
	25.0	2.7	2.1	2.7	2.2	2.9	2.2	3.0	2.3	3.1	2.3	3.3	2.3	3.5	2.3
	27.5	2.6	2.1	2.7	2.2	2.9	2.2	3.0	2.3	3.1	2.3	3.2	2.3	3.4	2.2
	30.0	2.6	2.1	2.6	2.2	2.8	2.1	2.9	2.3	3.0	2.3	3.2	2.2	3.4	2.2
	32.5	2.5	2.1	2.6	2.1	2.8	2.1	2.8	2.3	2.9	2.2	3.1	2.2	3.3	2.2
	35.0	2.5	2.1	2.5	2.1	2.7	2.1	2.8	2.2	2.9	2.2	3.0	2.2	3.2	2.2
	37.5	2.5	2.0	2.5	2.1	2.6	2.1	2.7	2.2	2.8	2.2	3.0	2.2	3.2	2.1
	40.0	2.4	2.0	2.4	2.1	2.6	2.0	2.7	2.2	2.8	2.2	2.9	2.1	3.1	2.1
43.0	2.4	2.0	2.4	2.0	2.5	2.0	2.6	2.2	2.7	2.1	2.8	2.1	3.0	2.1	
32 (3.6)	20.0	3.5	2.6	3.6	2.7	3.9	2.7	4.0	2.8	4.2	2.8	4.4	2.8	4.7	2.7
	22.5	3.5	2.6	3.6	2.7	3.8	2.6	4.0	2.8	4.1	2.8	4.3	2.7	4.6	2.7
	25.0	3.4	2.6	3.5	2.6	3.8	2.6	3.9	2.8	4.0	2.7	4.2	2.7	4.5	2.7
	27.5	3.4	2.5	3.5	2.6	3.7	2.6	3.8	2.7	3.9	2.7	4.2	2.7	4.4	2.6
	30.0	3.3	2.5	3.4	2.6	3.6	2.5	3.7	2.7	3.8	2.7	4.1	2.6	4.3	2.6
	32.5	3.3	2.5	3.3	2.5	3.5	2.5	3.7	2.7	3.8	2.7	4.0	2.6	4.2	2.6
	35.0	3.2	2.4	3.3	2.5	3.5	2.5	3.6	2.6	3.7	2.6	3.9	2.6	4.2	2.5
	37.5	3.2	2.4	3.2	2.5	3.4	2.4	3.5	2.6	3.6	2.6	3.8	2.6	4.1	2.5
	40.0	3.1	2.4	3.1	2.4	3.3	2.4	3.4	2.6	3.5	2.6	3.8	2.5	4.0	2.5
43.0	3.0	2.4	3.0	2.4	3.2	2.4	3.3	2.5	3.4	2.5	3.7	2.5	3.9	2.4	
40 (4.5)	20.0	4.4	3.0	4.5	3.1	4.9	3.1	5.0	3.3	5.2	3.3	5.5	3.2	5.8	3.2
	22.5	4.4	3.0	4.5	3.1	4.8	3.1	4.9	3.2	5.1	3.2	5.4	3.2	5.7	3.1
	25.0	4.3	3.0	4.4	3.1	4.7	3.0	4.9	3.2	5.0	3.2	5.3	3.1	5.6	3.1
	27.5	4.2	3.0	4.3	3.0	4.6	3.0	4.8	3.2	4.9	3.1	5.2	3.1	5.5	3.1
	30.0	4.1	2.9	4.2	3.0	4.5	3.0	4.7	3.1	4.8	3.1	5.1	3.1	5.4	3.0
	32.5	4.1	2.9	4.2	2.9	4.4	2.9	4.6	3.1	4.7	3.1	5.0	3.0	5.3	3.0
	35.0	4.0	2.9	4.1	2.9	4.3	2.9	4.5	3.0	4.6	3.0	4.9	3.0	5.2	2.9
	37.5	3.9	2.8	4.0	2.9	4.2	2.8	4.4	3.0	4.5	3.0	4.8	2.9	5.1	2.9
	40.0	3.9	2.8	3.9	2.8	4.2	2.8	4.3	2.9	4.4	2.9	4.7	2.9	5.0	2.8
43.0	3.8	2.7	3.8	2.8	4.0	2.7	4.2	2.9	4.3	2.9	4.6	2.8	4.8	2.8	
50 (5.6)	20.0	5.4	3.9	5.6	4.0	6.1	4.0	6.3	4.2	6.5	4.2	6.9	4.1	7.3	4.1
	22.5	5.4	3.9	5.6	4.0	6.0	3.9	6.2	4.2	6.3	4.1	6.7	4.1	7.1	4.0
	25.0	5.3	3.8	5.5	3.9	5.8	3.9	6.0	4.1	6.2	4.1	6.6	4.0	7.0	4.0
	27.5	5.3	3.8	5.4	3.9	5.7	3.8	5.9	4.0	6.1	4.0	6.5	4.0	6.9	3.9
	30.0	5.2	3.7	5.3	3.8	5.6	3.8	5.8	4.0	6.0	4.0	6.4	3.9	6.7	3.9
	32.5	5.1	3.7	5.2	3.8	5.5	3.7	5.7	3.9	5.9	3.9	6.2	3.9	6.6	3.8
	35.0	5.0	3.6	5.1	3.7	5.4	3.7	5.6	3.9	5.7	3.9	6.1	3.8	6.5	3.8
	37.5	4.9	3.6	5.0	3.7	5.3	3.6	5.5	3.8	5.6	3.8	6.0	3.8	6.3	3.7
	40.0	4.8	3.6	4.9	3.6	5.2	3.6	5.3	3.8	5.5	3.8	5.8	3.7	6.2	3.7
43.0	4.7	3.5	4.7	3.5	5.0	3.5	5.2	3.7	5.4	3.7	5.7	3.7	6.0	3.6	
63 (7.1)	20.0	6.9	4.8	7.1	4.9	7.7	4.9	7.9	5.2	8.2	5.2	8.7	5.1	9.2	5.0
	22.5	6.9	4.8	7.1	4.9	7.6	4.9	7.8	5.1	8.0	5.1	8.5	5.0	9.1	5.0
	25.0	6.8	4.7	7.0	4.8	7.4	4.8	7.7	5.1	7.9	5.0	8.4	5.0	8.9	4.9
	27.5	6.7	4.7	6.8	4.8	7.3	4.8	7.5	5.0	7.7	5.0	8.2	4.9	8.7	4.8
	30.0	6.5	4.6	6.7	4.7	7.1	4.7	7.4	4.9	7.6	4.9	8.1	4.8	8.5	4.8
	32.5	6.4	4.6	6.6	4.6	7.0	4.6	7.2	4.9	7.4	4.8	7.9	4.8	8.4	4.7
	35.0	6.3	4.5	6.4	4.6	6.8	4.5	7.1	4.8	7.3	4.8	7.7	4.7	8.2	4.6
	37.5	6.2	4.5	6.3	4.5	6.7	4.5	6.9	4.7	7.1	4.7	7.6	4.6	8.0	4.6
	40.0	6.1	4.4	6.2	4.4	6.6	4.4	6.8	4.7	7.0	4.6	7.4	4.6	7.8	4.5
43.0	6.0	4.3	6.0	4.4	6.4	4.3	6.6	4.6	6.8	4.6	7.2	4.5	7.6	4.4	
80 (9.0)	20.0	8.7	6.3	9.0	6.5	9.7	6.5	10.1	6.9	10.4	6.9	11.0	6.8	11.7	6.7
	22.5	8.7	6.3	9.0	6.5	9.6	6.5	9.9	6.8	10.2	6.8	10.8	6.7	11.5	6.6
	25.0	8.6	6.3	8.8	6.4	9.4	6.4	9.7	6.7	10.0	6.7	10.6	6.6	11.3	6.5
	27.5	8.4	6.2	8.6	6.3	9.2	6.3	9.5	6.7	9.8	6.6	10.4	6.5	11.0	6.4
	30.0	8.3	6.1	8.5	6.3	9.0	6.2	9.3	6.6	9.6	6.5	10.2	6.5	10.8	6.4
	32.5	8.2	6.1	8.3	6.2	8.9	6.1	9.1	6.5	9.4	6.5	10.0	6.4	10.6	6.3
	35.0	8.0	6.0	8.1	6.1	8.7	6.0	9.0	6.4	9.2	6.4	9.8	6.3	10.4	6.2
	37.5	7.9	5.9	8.0	6.0	8.5	6.0	8.8	6.3	9.0	6.3	9.6	6.2	10.2	6.1
	40.0	7.7	5.8	7.8	5.9	8.3	5.9	8.6	6.3	8.8	6.2	9.4	6.1	9.9	6.0
43.0	7.6	5.8	7.6	5.8	8.1	5.8	8.4	6.2	8.6	6.1	9.1	6.0	9.7	6.0	

kcal/h=kW x 860 , BTU/h = kW x 3,412

4. Cooling [Ceiling cassette (2-way flow type)]

PLFY-P-VLMD-E

CA:Capacity(kW) , SHC:Sensible Heat Capacity(kW)

Model size (Rated kW)	Outdoor air temp. °C D.B.	Indoor air temp.													
		21.5°C D.B. 15°C W.B.		23°C D.B. 16°C W.B.		25°C D.B. 18°C W.B.		27°C D.B. 19°C W.B.		28°C D.B. 20°C W.B.		30°C D.B. 22°C W.B.		32°C D.B. 24°C W.B.	
		CA	SHC	CA	SHC	CA	SHC	CA	SHC	CA	SHC	CA	SHC	CA	SHC
100 (11.2)	20.0	10.9	7.8	11.3	8.0	12.1	8.0	12.5	8.5	12.9	8.4	13.7	8.3	14.5	8.2
	22.5	10.8	7.8	11.2	8.0	11.9	7.9	12.3	8.4	12.7	8.3	13.5	8.2	14.3	8.1
	25.0	10.7	7.7	11.0	7.9	11.7	7.8	12.1	8.3	12.5	8.2	13.2	8.1	14.0	8.0
	27.5	10.5	7.6	10.8	7.8	11.5	7.7	11.8	8.2	12.2	8.1	13.0	8.0	13.7	7.9
	30.0	10.3	7.5	10.6	7.7	11.2	7.6	11.6	8.1	12.0	8.0	12.7	7.9	13.5	7.8
	32.5	10.2	7.4	10.3	7.6	11.0	7.5	11.4	8.0	11.7	7.9	12.4	7.8	13.2	7.7
	35.0	10.0	7.3	10.1	7.5	10.8	7.4	11.2	7.9	11.5	7.8	12.2	7.7	12.9	7.6
	37.5	9.8	7.3	9.9	7.4	10.6	7.3	10.9	7.7	11.2	7.7	11.9	7.6	12.6	7.5
	40.0	9.6	7.2	9.7	7.3	10.3	7.2	10.7	7.6	11.0	7.6	11.7	7.5	12.4	7.4
43.0	9.4	7.1	9.5	7.1	10.1	7.1	10.4	7.5	10.7	7.5	11.4	7.4	12.1	7.3	
125 (14.0)	20.0	13.6	9.9	14.1	10.2	15.1	10.2	15.7	10.8	16.2	10.7	17.2	10.6	18.2	10.4
	22.5	13.6	9.9	14.0	10.2	14.9	10.1	15.4	10.7	15.9	10.6	16.8	10.5	17.8	10.3
	25.0	13.3	9.8	13.7	10.0	14.6	10.0	15.1	10.5	15.6	10.5	16.5	10.3	17.5	10.2
	27.5	13.1	9.7	13.5	9.9	14.3	9.8	14.8	10.4	15.3	10.3	16.2	10.2	17.2	10.1
	30.0	12.9	9.6	13.2	9.8	14.1	9.7	14.5	10.3	15.0	10.2	15.9	10.1	16.8	9.9
	32.5	12.7	9.4	12.9	9.6	13.8	9.6	14.2	10.1	14.7	10.1	15.6	10.0	16.5	9.8
	35.0	12.5	9.3	12.7	9.5	13.5	9.4	14.0	10.1	14.4	10.0	15.2	9.8	16.2	9.7
	37.5	12.3	9.2	12.4	9.4	13.2	9.3	13.6	9.9	14.1	9.8	14.9	9.7	15.8	9.6
	40.0	12.0	9.1	12.2	9.3	12.9	9.2	13.3	9.8	13.8	9.7	14.6	9.6	15.5	9.4
43.0	11.8	9.0	11.8	9.1	12.6	9.0	13.0	9.6	13.4	9.6	14.2	9.5	15.1	9.3	

kcal/h=kW x 860 , BTU/h = kW x 3,412

4. Cooling [Ceiling cassette (2-way flow type)]

4-3. Cooling capacity with PUHY-RP450-650YSJM

PLFY-P-VLMD-E

CA:Capacity(kW) , SHC:Sensible Heat Capacity(kW)

Model size (Rated kW)	Outdoor air temp. °C D.B.	Indoor air temp.													
		21.5°C D.B. 15°C W.B.		23°C D.B. 16°C W.B.		25°C D.B. 18°C W.B.		27°C D.B. 19°C W.B.		28°C D.B. 20°C W.B.		30°C D.B. 22°C W.B.		32°C D.B. 24°C W.B.	
		CA	SHC	CA	SHC	CA	SHC	CA	SHC	CA	SHC	CA	SHC	CA	SHC
20 (2.2)	20.0	2.1	1.9	2.1	1.9	2.3	1.9	2.4	2.1	2.4	2.1	2.6	2.0	2.8	2.0
	22.5	2.1	1.9	2.1	1.9	2.3	1.9	2.3	2.1	2.4	2.0	2.6	2.0	2.7	2.0
	25.0	2.0	1.8	2.1	1.9	2.2	1.9	2.3	2.0	2.4	2.0	2.5	2.0	2.7	2.0
	27.5	2.0	1.8	2.1	1.9	2.2	1.9	2.3	2.0	2.4	2.0	2.5	2.0	2.7	2.0
	30.0	2.0	1.8	2.0	1.9	2.2	1.9	2.3	2.0	2.3	2.0	2.5	2.0	2.7	2.0
	32.5	2.0	1.8	2.0	1.9	2.2	1.9	2.2	2.0	2.3	2.0	2.5	2.0	2.6	2.0
	35.0	2.0	1.8	2.0	1.9	2.1	1.9	2.2	2.0	2.3	2.0	2.5	2.0	2.6	2.0
	37.5	1.9	1.8	2.0	1.9	2.1	1.8	2.2	2.0	2.3	2.0	2.4	2.0	2.6	2.0
	40.0	1.9	1.8	1.9	1.8	2.1	1.8	2.2	2.0	2.2	2.0	2.4	2.0	2.6	1.9
43.0	1.9	1.8	1.9	1.8	2.1	1.8	2.1	2.0	2.2	2.0	2.4	2.0	2.5	1.9	
25 (2.8)	20.0	2.6	2.1	2.7	2.2	2.9	2.2	3.0	2.3	3.1	2.3	3.3	2.3	3.5	2.3
	22.5	2.6	2.1	2.7	2.2	2.9	2.2	3.0	2.3	3.1	2.3	3.3	2.3	3.5	2.2
	25.0	2.6	2.1	2.7	2.2	2.9	2.2	2.9	2.3	3.0	2.3	3.2	2.3	3.5	2.2
	27.5	2.6	2.1	2.6	2.1	2.8	2.1	2.9	2.3	3.0	2.3	3.2	2.3	3.4	2.2
	30.0	2.5	2.1	2.6	2.1	2.8	2.1	2.9	2.3	3.0	2.3	3.2	2.2	3.4	2.2
	32.5	2.5	2.1	2.6	2.1	2.8	2.1	2.9	2.3	3.0	2.3	3.2	2.2	3.4	2.2
	35.0	2.5	2.0	2.5	2.1	2.7	2.1	2.8	2.2	2.9	2.2	3.1	2.2	3.3	2.2
	37.5	2.5	2.0	2.5	2.1	2.7	2.1	2.8	2.2	2.9	2.2	3.1	2.2	3.3	2.2
	40.0	2.4	2.0	2.5	2.1	2.7	2.1	2.8	2.2	2.9	2.2	3.1	2.2	3.3	2.2
43.0	2.4	2.0	2.4	2.1	2.6	2.1	2.7	2.2	2.8	2.2	3.0	2.2	3.2	2.2	
32 (3.6)	20.0	3.4	2.5	3.5	2.6	3.7	2.6	3.9	2.8	4.0	2.7	4.3	2.7	4.5	2.7
	22.5	3.4	2.5	3.5	2.6	3.7	2.6	3.8	2.7	4.0	2.7	4.2	2.7	4.5	2.7
	25.0	3.3	2.5	3.4	2.6	3.7	2.6	3.8	2.7	3.9	2.7	4.2	2.7	4.4	2.7
	27.5	3.3	2.5	3.4	2.6	3.6	2.5	3.8	2.7	3.9	2.7	4.1	2.7	4.4	2.6
	30.0	3.3	2.5	3.3	2.5	3.6	2.5	3.7	2.7	3.8	2.7	4.1	2.7	4.4	2.6
	32.5	3.2	2.5	3.3	2.5	3.5	2.5	3.7	2.7	3.8	2.7	4.1	2.6	4.3	2.6
	35.0	3.2	2.4	3.3	2.5	3.5	2.5	3.6	2.6	3.8	2.6	4.0	2.6	4.3	2.6
	37.5	3.2	2.4	3.2	2.5	3.5	2.5	3.6	2.6	3.7	2.6	4.0	2.6	4.2	2.6
	40.0	3.1	2.4	3.2	2.5	3.4	2.5	3.5	2.6	3.7	2.6	3.9	2.6	4.2	2.6
43.0	3.1	2.4	3.1	2.4	3.4	2.4	3.5	2.6	3.6	2.6	3.9	2.6	4.2	2.6	
40 (4.5)	20.0	4.3	3.0	4.4	3.1	4.7	3.0	4.8	3.2	5.0	3.2	5.3	3.1	5.7	3.1
	22.5	4.2	3.0	4.3	3.0	4.6	3.0	4.8	3.2	4.9	3.2	5.3	3.1	5.6	3.1
	25.0	4.2	2.9	4.3	3.0	4.6	3.0	4.7	3.1	4.9	3.1	5.2	3.1	5.6	3.1
	27.5	4.1	2.9	4.2	3.0	4.5	3.0	4.7	3.1	4.8	3.1	5.2	3.1	5.5	3.0
	30.0	4.1	2.9	4.2	2.9	4.5	2.9	4.6	3.1	4.8	3.1	5.1	3.1	5.5	3.0
	32.5	4.0	2.9	4.1	2.9	4.4	2.9	4.6	3.1	4.7	3.1	5.1	3.0	5.4	3.0
	35.0	4.0	2.8	4.1	2.9	4.4	2.9	4.5	3.0	4.7	3.0	5.0	3.0	5.4	3.0
	37.5	4.0	2.8	4.0	2.9	4.3	2.9	4.5	3.0	4.6	3.0	5.0	3.0	5.3	3.0
	40.0	3.9	2.8	4.0	2.8	4.3	2.8	4.4	3.0	4.6	3.0	4.9	3.0	5.3	3.0
43.0	3.9	2.8	3.9	2.8	4.2	2.8	4.4	3.0	4.5	3.0	4.9	3.0	5.2	2.9	
50 (5.6)	20.0	5.3	3.8	5.5	3.9	5.8	3.9	6.0	4.1	6.2	4.1	6.6	4.0	7.0	4.0
	22.5	5.2	3.8	5.4	3.9	5.8	3.9	6.0	4.1	6.2	4.0	6.6	4.0	7.0	4.0
	25.0	5.2	3.7	5.3	3.8	5.7	3.8	5.9	4.0	6.1	4.0	6.5	4.0	6.9	3.9
	27.5	5.1	3.7	5.3	3.8	5.6	3.8	5.8	4.0	6.0	4.0	6.4	4.0	6.9	3.9
	30.0	5.1	3.7	5.2	3.8	5.6	3.8	5.8	4.0	6.0	4.0	6.4	3.9	6.8	3.9
	32.5	5.0	3.7	5.1	3.7	5.5	3.7	5.7	4.0	5.9	3.9	6.3	3.9	6.7	3.9
	35.0	5.0	3.6	5.1	3.7	5.4	3.7	5.6	3.9	5.8	3.9	6.2	3.9	6.7	3.8
	37.5	4.9	3.6	5.0	3.7	5.4	3.7	5.6	3.9	5.8	3.9	6.2	3.9	6.6	3.8
	40.0	4.9	3.6	4.9	3.6	5.3	3.6	5.5	3.9	5.7	3.9	6.1	3.8	6.5	3.8
43.0	4.8	3.5	4.9	3.6	5.2	3.6	5.4	3.8	5.6	3.8	6.0	3.8	6.5	3.8	
63 (7.1)	20.0	6.7	4.7	6.9	4.8	7.4	4.8	7.6	5.1	7.9	5.0	8.4	5.0	8.9	4.9
	22.5	6.6	4.7	6.8	4.8	7.3	4.8	7.6	5.0	7.8	5.0	8.3	4.9	8.8	4.9
	25.0	6.6	4.6	6.8	4.7	7.2	4.7	7.5	5.0	7.7	5.0	8.2	4.9	8.8	4.9
	27.5	6.5	4.6	6.7	4.7	7.2	4.7	7.4	4.9	7.6	4.9	8.2	4.9	8.7	4.8
	30.0	6.4	4.6	6.6	4.7	7.1	4.7	7.3	4.9	7.6	4.9	8.1	4.8	8.6	4.8
	32.5	6.4	4.5	6.5	4.6	7.0	4.6	7.2	4.9	7.5	4.9	8.0	4.8	8.5	4.8
	35.0	6.3	4.5	6.4	4.6	6.9	4.6	7.1	4.8	7.4	4.8	7.9	4.8	8.5	4.7
	37.5	6.2	4.5	6.3	4.5	6.8	4.5	7.1	4.8	7.3	4.8	7.8	4.8	8.4	4.7
	40.0	6.2	4.4	6.3	4.5	6.7	4.5	7.0	4.8	7.2	4.8	7.8	4.7	8.3	4.7
43.0	6.1	4.4	6.2	4.5	6.7	4.5	6.9	4.7	7.1	4.7	7.7	4.7	8.2	4.6	
80 (9.0)	20.0	8.5	6.2	8.8	6.4	9.4	6.4	9.7	6.7	10.0	6.7	10.6	6.6	11.3	6.5
	22.5	8.4	6.2	8.7	6.3	9.3	6.3	9.6	6.7	9.9	6.7	10.5	6.6	11.2	6.5
	25.0	8.3	6.1	8.6	6.3	9.2	6.3	9.5	6.6	9.8	6.6	10.4	6.5	11.1	6.5
	27.5	8.3	6.1	8.5	6.2	9.1	6.2	9.4	6.6	9.7	6.6	10.3	6.5	11.0	6.4
	30.0	8.2	6.1	8.4	6.2	9.0	6.2	9.3	6.6	9.6	6.5	10.2	6.5	10.9	6.4
	32.5	8.1	6.0	8.3	6.1	8.9	6.1	9.2	6.5	9.5	6.5	10.1	6.4	10.8	6.4
	35.0	8.0	6.0	8.1	6.1	8.8	6.1	9.0	6.4	9.4	6.4	10.0	6.4	10.7	6.3
	37.5	7.9	5.9	8.0	6.1	8.7	6.0	9.0	6.4	9.3	6.4	9.9	6.4	10.6	6.3
	40.0	7.8	5.9	7.9	6.0	8.6	6.0	8.9	6.4	9.2	6.4	9.8	6.3	10.5	6.3
43.0	7.7	5.8	7.8	5.9	8.4	5.9	8.7	6.3	9.1	6.3	9.7	6.3	10.4	6.2	

kcal/h=kW x 860 , BTU/h = kW x 3,412

4. Cooling [Ceiling cassette (2-way flow type)]

PLFY-P-VLMD-E

CA:Capacity(kW) , SHC:Sensible Heat Capacity(kW)

Model size (Rated kW)	Outdoor air temp. °C D.B.	Indoor air temp.													
		21.5°C D.B. 15°C W.B.		23°C D.B. 16°C W.B.		25°C D.B. 18°C W.B.		27°C D.B. 19°C W.B.		28°C D.B. 20°C W.B.		30°C D.B. 22°C W.B.		32°C D.B. 24°C W.B.	
		CA	SHC	CA	SHC	CA	SHC	CA	SHC	CA	SHC	CA	SHC	CA	SHC
100 (11.2)	20.0	10.6	7.6	10.9	7.8	11.7	7.8	12.0	8.3	12.4	8.2	13.2	8.1	14.1	8.0
	22.5	10.5	7.6	10.8	7.8	11.5	7.8	11.9	8.2	12.3	8.2	13.1	8.1	13.9	8.0
	25.0	10.4	7.5	10.6	7.7	11.4	7.7	11.8	8.1	12.2	8.1	13.0	8.0	13.8	7.9
	27.5	10.3	7.5	10.5	7.7	11.3	7.6	11.7	8.1	12.1	8.1	12.9	8.0	13.7	7.9
	30.0	10.2	7.4	10.4	7.6	11.2	7.6	11.5	8.0	11.9	8.0	12.7	7.9	13.6	7.8
	32.5	10.1	7.4	10.3	7.5	11.0	7.5	11.4	8.0	11.8	7.9	12.6	7.9	13.5	7.8
	35.0	9.9	7.3	10.1	7.5	10.9	7.5	11.2	7.9	11.7	7.9	12.5	7.8	13.3	7.7
	37.5	9.8	7.3	10.0	7.4	10.8	7.4	11.2	7.9	11.6	7.8	12.4	7.8	13.2	7.7
	40.0	9.7	7.2	9.9	7.4	10.6	7.3	11.0	7.8	11.4	7.8	12.2	7.7	13.1	7.7
43.0	9.6	7.2	9.7	7.3	10.5	7.3	10.9	7.7	11.3	7.7	12.1	7.7	12.9	7.6	
125 (14.0)	20.0	13.2	9.7	13.6	10.0	14.6	9.9	15.1	10.5	15.5	10.5	16.5	10.3	17.6	10.2
	22.5	13.1	9.7	13.5	9.9	14.4	9.9	14.9	10.4	15.4	10.4	16.4	10.3	17.4	10.2
	25.0	13.0	9.6	13.3	9.8	14.3	9.8	14.7	10.4	15.2	10.3	16.2	10.2	17.3	10.1
	27.5	12.8	9.5	13.2	9.8	14.1	9.7	14.6	10.3	15.1	10.3	16.1	10.2	17.1	10.0
	30.0	12.7	9.5	13.0	9.7	13.9	9.6	14.4	10.2	14.9	10.2	15.9	10.1	17.0	10.0
	32.5	12.6	9.4	12.8	9.6	13.8	9.6	14.3	10.2	14.8	10.1	15.8	10.0	16.8	9.9
	35.0	12.4	9.3	12.7	9.5	13.6	9.5	14.0	10.1	14.6	10.1	15.6	10.0	16.7	9.9
	37.5	12.3	9.3	12.5	9.4	13.5	9.4	14.0	10.0	14.4	10.0	15.5	9.9	16.5	9.8
	40.0	12.2	9.2	12.4	9.4	13.3	9.4	13.8	10.0	14.3	9.9	15.3	9.9	16.4	9.8
43.0	12.0	9.1	12.2	9.3	13.1	9.3	13.6	9.9	14.1	9.9	15.1	9.8	16.2	9.7	

kcal/h=kW x 860 , BTU/h = kW x 3,412

4. Cooling [Ceiling cassette (2-way flow type)]

4-4. Cooling capacity with PUYH-RP700-800YSJM

PLFY-P-VLMD-E

CA:Capacity(kW) , SHC:Sensible Heat Capacity(kW)

Model size (Rated kW)	Outdoor air temp. °C D.B.	Indoor air temp.													
		21.5°C D.B. 15°C W.B.		23°C D.B. 16°C W.B.		25°C D.B. 18°C W.B.		27°C D.B. 19°C W.B.		28°C D.B. 20°C W.B.		30°C D.B. 22°C W.B.		32°C D.B. 24°C W.B.	
		CA	SHC	CA	SHC	CA	SHC	CA	SHC	CA	SHC	CA	SHC	CA	SHC
20 (2.2)	20.0	2.1	1.9	2.2	2.0	2.4	1.9	2.4	2.1	2.5	2.1	2.7	2.1	2.9	2.0
	22.5	2.1	1.9	2.2	1.9	2.3	1.9	2.4	2.1	2.5	2.1	2.6	2.1	2.8	2.0
	25.0	2.1	1.9	2.1	1.9	2.3	1.9	2.4	2.1	2.4	2.1	2.6	2.0	2.8	2.0
	27.5	2.0	1.8	2.1	1.9	2.2	1.9	2.3	2.0	2.4	2.0	2.6	2.0	2.7	2.0
	30.0	2.0	1.8	2.0	1.9	2.2	1.9	2.3	2.0	2.4	2.0	2.5	2.0	2.7	2.0
	32.5	1.9	1.8	2.0	1.9	2.2	1.9	2.2	2.0	2.3	2.0	2.5	2.0	2.6	2.0
	35.0	1.9	1.8	2.0	1.9	2.1	1.8	2.2	2.0	2.3	2.0	2.4	2.0	2.6	1.9
	37.5	1.9	1.8	1.9	1.8	2.1	1.8	2.1	2.0	2.2	2.0	2.4	2.0	2.5	1.9
	40.0	1.8	1.8	1.9	1.8	2.0	1.8	2.1	2.0	2.2	2.0	2.3	1.9	2.5	1.9
43.0	1.8	1.7	1.8	1.8	2.0	1.8	2.1	1.9	2.1	1.9	2.3	1.9	2.4	1.9	
25 (2.8)	20.0	2.7	2.1	2.8	2.2	3.0	2.2	3.1	2.4	3.2	2.4	3.4	2.3	3.7	2.3
	22.5	2.7	2.1	2.8	2.2	3.0	2.2	3.1	2.3	3.2	2.3	3.4	2.3	3.6	2.3
	25.0	2.6	2.1	2.7	2.2	2.9	2.2	3.0	2.3	3.1	2.3	3.3	2.3	3.5	2.3
	27.5	2.6	2.1	2.7	2.2	2.9	2.2	3.0	2.3	3.1	2.3	3.3	2.3	3.5	2.2
	30.0	2.5	2.1	2.6	2.1	2.8	2.1	2.9	2.3	3.0	2.3	3.2	2.2	3.4	2.2
	32.5	2.5	2.0	2.6	2.1	2.7	2.1	2.8	2.3	2.9	2.2	3.1	2.2	3.3	2.2
	35.0	2.4	2.0	2.5	2.1	2.7	2.1	2.8	2.2	2.9	2.2	3.1	2.2	3.3	2.2
	37.5	2.4	2.0	2.5	2.1	2.6	2.1	2.7	2.2	2.8	2.2	3.0	2.2	3.2	2.2
	40.0	2.3	2.0	2.4	2.0	2.6	2.0	2.7	2.2	2.8	2.2	3.0	2.2	3.1	2.1
43.0	2.3	2.0	2.4	2.0	2.5	2.0	2.6	2.2	2.7	2.2	2.9	2.1	3.1	2.1	
32 (3.6)	20.0	3.5	2.6	3.6	2.7	3.9	2.7	4.0	2.8	4.1	2.8	4.4	2.8	4.7	2.7
	22.5	3.4	2.6	3.5	2.6	3.8	2.6	3.9	2.8	4.1	2.8	4.3	2.7	4.6	2.7
	25.0	3.4	2.5	3.5	2.6	3.7	2.6	3.9	2.8	4.0	2.7	4.3	2.7	4.5	2.7
	27.5	3.3	2.5	3.4	2.6	3.7	2.6	3.8	2.7	3.9	2.7	4.2	2.7	4.5	2.7
	30.0	3.2	2.5	3.4	2.5	3.6	2.5	3.7	2.7	3.9	2.7	4.1	2.7	4.4	2.6
	32.5	3.2	2.4	3.3	2.5	3.5	2.5	3.7	2.7	3.8	2.7	4.0	2.6	4.3	2.6
	35.0	3.1	2.4	3.2	2.5	3.5	2.5	3.6	2.6	3.7	2.6	4.0	2.6	4.2	2.6
	37.5	3.1	2.4	3.2	2.5	3.4	2.4	3.5	2.6	3.6	2.6	3.9	2.6	4.1	2.5
	40.0	3.0	2.4	3.1	2.4	3.3	2.4	3.4	2.6	3.6	2.6	3.8	2.5	4.0	2.5
43.0	2.9	2.3	3.0	2.4	3.2	2.4	3.4	2.5	3.5	2.5	3.7	2.5	3.9	2.5	
40 (4.5)	20.0	4.3	3.0	4.5	3.1	4.8	3.1	5.0	3.3	5.2	3.3	5.5	3.2	5.9	3.2
	22.5	4.3	3.0	4.4	3.1	4.7	3.1	4.9	3.2	5.1	3.2	5.4	3.2	5.8	3.1
	25.0	4.2	3.0	4.3	3.0	4.7	3.0	4.8	3.2	5.0	3.2	5.3	3.2	5.7	3.1
	27.5	4.1	2.9	4.3	3.0	4.6	3.0	4.7	3.1	4.9	3.1	5.2	3.1	5.6	3.1
	30.0	4.1	2.9	4.2	3.0	4.5	2.9	4.7	3.1	4.8	3.1	5.1	3.1	5.5	3.0
	32.5	4.0	2.8	4.1	2.9	4.4	2.9	4.6	3.1	4.7	3.1	5.0	3.0	5.4	3.0
	35.0	3.9	2.8	4.0	2.9	4.3	2.9	4.5	3.0	4.6	3.0	4.9	3.0	5.3	3.0
	37.5	3.8	2.8	4.0	2.8	4.2	2.8	4.4	3.0	4.5	3.0	4.8	3.0	5.2	2.9
	40.0	3.8	2.7	3.9	2.8	4.2	2.8	4.3	2.9	4.5	2.9	4.8	2.9	5.1	2.9
43.0	3.7	2.7	3.8	2.7	4.1	2.7	4.2	2.9	4.3	2.9	4.6	2.9	4.9	2.8	
50 (5.6)	20.0	5.4	3.9	5.6	4.0	6.0	4.0	6.2	4.2	6.4	4.2	6.9	4.1	7.3	4.1
	22.5	5.3	3.8	5.5	3.9	5.9	3.9	6.1	4.1	6.3	4.1	6.7	4.1	7.2	4.0
	25.0	5.2	3.8	5.4	3.9	5.8	3.9	6.0	4.1	6.2	4.1	6.6	4.0	7.0	4.0
	27.5	5.1	3.7	5.3	3.8	5.7	3.8	5.9	4.0	6.1	4.0	6.5	4.0	6.9	3.9
	30.0	5.0	3.7	5.2	3.8	5.6	3.8	5.8	4.0	6.0	4.0	6.4	3.9	6.8	3.9
	32.5	5.0	3.6	5.1	3.7	5.5	3.7	5.7	3.9	5.9	3.9	6.3	3.9	6.7	3.8
	35.0	4.9	3.6	5.0	3.7	5.4	3.7	5.6	3.9	5.8	3.9	6.2	3.8	6.5	3.8
	37.5	4.8	3.5	4.9	3.6	5.3	3.6	5.5	3.8	5.7	3.8	6.0	3.8	6.4	3.7
	40.0	4.7	3.5	4.8	3.6	5.2	3.6	5.4	3.8	5.5	3.8	5.9	3.7	6.3	3.7
43.0	4.6	3.4	4.7	3.5	5.1	3.5	5.2	3.7	5.4	3.7	5.8	3.7	6.1	3.6	
63 (7.1)	20.0	6.9	4.8	7.1	4.9	7.6	4.9	7.9	5.2	8.2	5.2	8.7	5.1	9.3	5.0
	22.5	6.7	4.7	7.0	4.9	7.5	4.9	7.8	5.1	8.0	5.1	8.6	5.0	9.1	5.0
	25.0	6.6	4.7	6.9	4.8	7.4	4.8	7.6	5.1	7.9	5.0	8.4	5.0	8.9	4.9
	27.5	6.5	4.6	6.7	4.7	7.2	4.7	7.5	5.0	7.7	5.0	8.3	4.9	8.8	4.9
	30.0	6.4	4.5	6.6	4.7	7.1	4.7	7.3	4.9	7.6	4.9	8.1	4.9	8.6	4.8
	32.5	6.3	4.5	6.5	4.6	7.0	4.6	7.2	4.9	7.5	4.8	7.9	4.8	8.5	4.7
	35.0	6.2	4.4	6.4	4.5	6.8	4.5	7.1	4.8	7.3	4.8	7.8	4.7	8.3	4.7
	37.5	6.1	4.4	6.2	4.5	6.7	4.5	6.9	4.7	7.2	4.7	7.6	4.7	8.1	4.6
	40.0	5.9	4.3	6.1	4.4	6.6	4.4	6.8	4.7	7.0	4.7	7.5	4.6	8.0	4.6
43.0	5.8	4.2	6.0	4.3	6.4	4.3	6.6	4.6	6.9	4.6	7.3	4.5	7.8	4.5	
80 (9.0)	20.0	8.7	6.3	9.0	6.5	9.7	6.5	10.0	6.9	10.3	6.9	11.0	6.8	11.7	6.7
	22.5	8.5	6.2	8.9	6.4	9.5	6.4	9.8	6.8	10.2	6.8	10.8	6.7	11.5	6.6
	25.0	8.4	6.2	8.7	6.4	9.3	6.3	9.7	6.7	10.0	6.7	10.6	6.6	11.3	6.5
	27.5	8.3	6.1	8.5	6.3	9.2	6.3	9.5	6.6	9.8	6.6	10.5	6.6	11.1	6.5
	30.0	8.1	6.0	8.4	6.2	9.0	6.2	9.3	6.6	9.6	6.5	10.3	6.5	10.9	6.4
	32.5	8.0	6.0	8.2	6.1	8.8	6.1	9.1	6.5	9.4	6.5	10.1	6.4	10.7	6.3
	35.0	7.8	5.9	8.1	6.1	8.7	6.0	9.0	6.4	9.3	6.4	9.9	6.3	10.5	6.2
	37.5	7.7	5.8	7.9	6.0	8.5	6.0	8.8	6.3	9.1	6.3	9.7	6.3	10.3	6.2
	40.0	7.5	5.7	7.7	5.9	8.3	5.9	8.6	6.3	8.9	6.2	9.5	6.2	10.1	6.1
43.0	7.4	5.7	7.6	5.8	8.1	5.8	8.4	6.2	8.7	6.2	9.3	6.1	9.9	6.0	

kcal/h=kw x 860 , BTU/h = kw x 3,412

4. Cooling [Ceiling cassette (2-way flow type)]

PLFY-P-VLMD-E

CA:Capacity(kW) , SHC:Sensible Heat Capacity(kW)

Model size (Rated kW)	Outdoor air temp. °C D.B.	Indoor air temp.													
		21.5°C D.B. 15°C W.B.		23°C D.B. 16°C W.B.		25°C D.B. 18°C W.B.		27°C D.B. 19°C W.B.		28°C D.B. 20°C W.B.		30°C D.B. 22°C W.B.		32°C D.B. 24°C W.B.	
		CA	SHC	CA	SHC	CA	SHC	CA	SHC	CA	SHC	CA	SHC	CA	SHC
100 (11.2)	20.0	10.8	7.8	11.2	8.0	12.0	8.0	12.5	8.4	12.9	8.4	13.7	8.3	14.6	8.2
	22.5	10.6	7.7	11.0	7.9	11.8	7.9	12.2	8.3	12.6	8.3	13.5	8.2	14.4	8.1
	25.0	10.5	7.6	10.8	7.8	11.6	7.8	12.0	8.2	12.4	8.2	13.3	8.1	14.1	8.0
	27.5	10.3	7.5	10.6	7.7	11.4	7.7	11.8	8.1	12.2	8.1	13.0	8.0	13.8	7.9
	30.0	10.1	7.4	10.4	7.6	11.2	7.6	11.6	8.0	12.0	8.0	12.8	7.9	13.6	7.8
	32.5	9.9	7.3	10.2	7.5	11.0	7.5	11.4	8.0	11.8	7.9	12.5	7.8	13.3	7.7
	35.0	9.7	7.2	10.0	7.4	10.8	7.4	11.2	7.9	11.5	7.8	12.3	7.8	13.1	7.6
	37.5	9.5	7.1	9.8	7.3	10.6	7.3	10.9	7.8	11.3	7.7	12.1	7.7	12.8	7.6
	40.0	9.4	7.0	9.6	7.2	10.4	7.2	10.7	7.7	11.1	7.6	11.8	7.6	12.6	7.5
43.0	9.2	6.9	9.4	7.1	10.1	7.1	10.5	7.6	10.8	7.5	11.5	7.5	12.3	7.4	
125 (14.0)	20.0	13.5	9.9	14.0	10.2	15.0	10.2	15.6	10.7	16.1	10.7	17.2	10.6	18.3	10.5
	22.5	13.3	9.8	13.8	10.1	14.8	10.0	15.3	10.6	15.8	10.6	16.9	10.5	17.9	10.3
	25.0	13.1	9.6	13.5	9.9	14.5	9.9	15.0	10.5	15.5	10.5	16.6	10.4	17.6	10.2
	27.5	12.8	9.5	13.3	9.8	14.3	9.8	14.8	10.4	15.3	10.3	16.3	10.2	17.3	10.1
	30.0	12.6	9.4	13.0	9.7	14.0	9.7	14.5	10.3	15.0	10.2	16.0	10.1	17.0	10.0
	32.5	12.4	9.3	12.8	9.6	13.7	9.6	14.2	10.1	14.7	10.1	15.7	10.0	16.7	9.9
	35.0	12.2	9.2	12.5	9.5	13.5	9.4	14.0	10.1	14.4	10.0	15.4	9.9	16.4	9.8
	37.5	11.9	9.1	12.3	9.3	13.2	9.3	13.7	9.9	14.1	9.9	15.1	9.8	16.0	9.7
	40.0	11.7	9.0	12.1	9.2	12.9	9.2	13.4	9.8	13.9	9.8	14.8	9.7	15.7	9.5
43.0	11.4	8.8	11.8	9.1	12.6	9.1	13.1	9.7	13.5	9.6	14.4	9.5	15.4	9.4	

kcal/h=kW x 860 , BTU/h = kW x 3,412

4. Cooling [Ceiling cassette (2-way flow type)]

4-5. Cooling capacity with PUHY-RP850-900YSJM

PLFY-P-VLMD-E

CA:Capacity(kW) , SHC:Sensible Heat Capacity(kW)

Model size (Rated kW)	Outdoor air temp. °C D.B.	Indoor air temp.													
		21.5°C D.B. 15°C W.B.		23°C D.B. 16°C W.B.		25°C D.B. 18°C W.B.		27°C D.B. 19°C W.B.		28°C D.B. 20°C W.B.		30°C D.B. 22°C W.B.		32°C D.B. 24°C W.B.	
		CA	SHC	CA	SHC	CA	SHC	CA	SHC	CA	SHC	CA	SHC	CA	SHC
20 (2.2)	20.0	2.1	1.9	2.1	1.9	2.3	1.9	2.4	2.1	2.4	2.1	2.6	2.0	2.8	2.0
	22.5	2.1	1.9	2.1	1.9	2.3	1.9	2.3	2.1	2.4	2.0	2.6	2.0	2.7	2.0
	25.0	2.0	1.8	2.1	1.9	2.2	1.9	2.3	2.0	2.4	2.0	2.5	2.0	2.7	2.0
	27.5	2.0	1.8	2.1	1.9	2.2	1.9	2.3	2.0	2.4	2.0	2.5	2.0	2.7	2.0
	30.0	2.0	1.8	2.0	1.9	2.2	1.9	2.3	2.0	2.3	2.0	2.5	2.0	2.7	2.0
	32.5	2.0	1.8	2.0	1.9	2.2	1.9	2.2	2.0	2.3	2.0	2.5	2.0	2.6	2.0
	35.0	2.0	1.8	2.0	1.9	2.1	1.9	2.2	2.0	2.3	2.0	2.5	2.0	2.6	2.0
	37.5	1.9	1.8	2.0	1.9	2.1	1.8	2.2	2.0	2.3	2.0	2.4	2.0	2.6	2.0
	40.0	1.9	1.8	1.9	1.8	2.1	1.8	2.2	2.0	2.2	2.0	2.4	2.0	2.6	1.9
	43.0	1.9	1.8	1.9	1.8	2.1	1.8	2.1	2.0	2.2	2.0	2.4	2.0	2.5	1.9
25 (2.8)	20.0	2.6	2.1	2.7	2.2	2.9	2.2	3.0	2.3	3.1	2.3	3.3	2.3	3.5	2.3
	22.5	2.6	2.1	2.7	2.2	2.9	2.2	3.0	2.3	3.1	2.3	3.3	2.3	3.5	2.2
	25.0	2.6	2.1	2.7	2.2	2.9	2.2	2.9	2.3	3.0	2.3	3.2	2.3	3.5	2.2
	27.5	2.6	2.1	2.6	2.1	2.8	2.1	2.9	2.3	3.0	2.3	3.2	2.3	3.4	2.2
	30.0	2.5	2.1	2.6	2.1	2.8	2.1	2.9	2.3	3.0	2.3	3.2	2.2	3.4	2.2
	32.5	2.5	2.1	2.6	2.1	2.8	2.1	2.9	2.3	3.0	2.3	3.2	2.2	3.4	2.2
	35.0	2.5	2.0	2.5	2.1	2.7	2.1	2.8	2.2	2.9	2.2	3.1	2.2	3.3	2.2
	37.5	2.5	2.0	2.5	2.1	2.7	2.1	2.8	2.2	2.9	2.2	3.1	2.2	3.3	2.2
	40.0	2.4	2.0	2.5	2.1	2.7	2.1	2.8	2.2	2.9	2.2	3.1	2.2	3.3	2.2
	43.0	2.4	2.0	2.4	2.1	2.6	2.1	2.7	2.2	2.8	2.2	3.0	2.2	3.2	2.2
32 (3.6)	20.0	3.4	2.5	3.5	2.6	3.7	2.6	3.9	2.8	4.0	2.7	4.3	2.7	4.5	2.7
	22.5	3.4	2.5	3.5	2.6	3.7	2.6	3.8	2.7	4.0	2.7	4.2	2.7	4.5	2.7
	25.0	3.3	2.5	3.4	2.6	3.7	2.6	3.8	2.7	3.9	2.7	4.2	2.7	4.4	2.7
	27.5	3.3	2.5	3.4	2.6	3.6	2.5	3.8	2.7	3.9	2.7	4.1	2.7	4.4	2.6
	30.0	3.3	2.5	3.3	2.5	3.6	2.5	3.7	2.7	3.8	2.7	4.1	2.7	4.4	2.6
	32.5	3.2	2.5	3.3	2.5	3.5	2.5	3.7	2.7	3.8	2.7	4.1	2.6	4.3	2.6
	35.0	3.2	2.4	3.3	2.5	3.5	2.5	3.6	2.6	3.8	2.6	4.0	2.6	4.3	2.6
	37.5	3.2	2.4	3.2	2.5	3.5	2.5	3.6	2.6	3.7	2.6	4.0	2.6	4.2	2.6
	40.0	3.1	2.4	3.2	2.5	3.4	2.5	3.5	2.6	3.7	2.6	3.9	2.6	4.2	2.6
	43.0	3.1	2.4	3.1	2.4	3.4	2.4	3.5	2.6	3.6	2.6	3.9	2.6	4.2	2.6
40 (4.5)	20.0	4.3	3.0	4.4	3.1	4.7	3.0	4.8	3.2	5.0	3.2	5.3	3.1	5.7	3.1
	22.5	4.2	3.0	4.3	3.0	4.6	3.0	4.8	3.2	4.9	3.2	5.3	3.1	5.6	3.1
	25.0	4.2	2.9	4.3	3.0	4.6	3.0	4.7	3.1	4.9	3.1	5.2	3.1	5.6	3.1
	27.5	4.1	2.9	4.2	3.0	4.5	3.0	4.7	3.1	4.8	3.1	5.2	3.1	5.5	3.0
	30.0	4.1	2.9	4.2	2.9	4.5	2.9	4.6	3.1	4.8	3.1	5.1	3.1	5.5	3.0
	32.5	4.0	2.9	4.1	2.9	4.4	2.9	4.6	3.1	4.7	3.1	5.1	3.0	5.4	3.0
	35.0	4.0	2.8	4.1	2.9	4.4	2.9	4.5	3.0	4.7	3.0	5.0	3.0	5.4	3.0
	37.5	4.0	2.8	4.0	2.9	4.3	2.9	4.5	3.0	4.6	3.0	5.0	3.0	5.3	3.0
	40.0	3.9	2.8	4.0	2.8	4.3	2.8	4.4	3.0	4.6	3.0	4.9	3.0	5.3	3.0
	43.0	3.9	2.8	3.9	2.8	4.2	2.8	4.4	3.0	4.5	3.0	4.9	3.0	5.2	2.9
50 (5.6)	20.0	5.3	3.8	5.5	3.9	5.8	3.9	6.0	4.1	6.2	4.1	6.6	4.0	7.0	4.0
	22.5	5.2	3.8	5.4	3.9	5.8	3.9	6.0	4.1	6.2	4.0	6.6	4.0	7.0	4.0
	25.0	5.2	3.7	5.3	3.8	5.7	3.8	5.9	4.0	6.1	4.0	6.5	4.0	6.9	3.9
	27.5	5.1	3.7	5.3	3.8	5.6	3.8	5.8	4.0	6.0	4.0	6.4	4.0	6.9	3.9
	30.0	5.1	3.7	5.2	3.8	5.6	3.8	5.8	4.0	6.0	4.0	6.4	3.9	6.8	3.9
	32.5	5.0	3.7	5.1	3.7	5.5	3.7	5.7	4.0	5.9	3.9	6.3	3.9	6.7	3.9
	35.0	5.0	3.6	5.1	3.7	5.4	3.7	5.6	3.9	5.8	3.9	6.2	3.9	6.7	3.8
	37.5	4.9	3.6	5.0	3.7	5.4	3.7	5.6	3.9	5.8	3.9	6.2	3.9	6.6	3.8
	40.0	4.9	3.6	4.9	3.6	5.3	3.6	5.5	3.9	5.7	3.9	6.1	3.8	6.5	3.8
	43.0	4.8	3.5	4.9	3.6	5.2	3.6	5.4	3.8	5.6	3.8	6.0	3.8	6.5	3.8
63 (7.1)	20.0	6.7	4.7	6.9	4.8	7.4	4.8	7.6	5.1	7.9	5.0	8.4	5.0	8.9	4.9
	22.5	6.6	4.7	6.8	4.8	7.3	4.8	7.6	5.0	7.8	5.0	8.3	4.9	8.8	4.9
	25.0	6.6	4.6	6.8	4.7	7.2	4.7	7.5	5.0	7.7	5.0	8.2	4.9	8.8	4.9
	27.5	6.5	4.6	6.7	4.7	7.2	4.7	7.4	4.9	7.6	4.9	8.2	4.9	8.7	4.8
	30.0	6.4	4.6	6.6	4.7	7.1	4.7	7.3	4.9	7.6	4.9	8.1	4.8	8.6	4.8
	32.5	6.4	4.5	6.5	4.6	7.0	4.6	7.2	4.9	7.5	4.9	8.0	4.8	8.5	4.8
	35.0	6.3	4.5	6.4	4.6	6.9	4.6	7.1	4.8	7.4	4.8	7.9	4.8	8.5	4.7
	37.5	6.2	4.5	6.3	4.5	6.8	4.5	7.1	4.8	7.3	4.8	7.8	4.8	8.4	4.7
	40.0	6.2	4.4	6.3	4.5	6.7	4.5	7.0	4.8	7.2	4.8	7.8	4.7	8.3	4.7
	43.0	6.1	4.4	6.2	4.5	6.7	4.5	6.9	4.7	7.1	4.7	7.7	4.7	8.2	4.6
80 (9.0)	20.0	8.5	6.2	8.8	6.4	9.4	6.4	9.7	6.7	10.0	6.7	10.6	6.6	11.3	6.5
	22.5	8.4	6.2	8.7	6.3	9.3	6.3	9.6	6.7	9.9	6.7	10.5	6.6	11.2	6.5
	25.0	8.3	6.1	8.6	6.3	9.2	6.3	9.5	6.6	9.8	6.6	10.4	6.5	11.1	6.5
	27.5	8.3	6.1	8.5	6.2	9.1	6.2	9.4	6.6	9.7	6.6	10.3	6.5	11.0	6.4
	30.0	8.2	6.1	8.4	6.2	9.0	6.2	9.3	6.6	9.6	6.5	10.2	6.5	10.9	6.4
	32.5	8.1	6.0	8.3	6.1	8.9	6.1	9.2	6.5	9.5	6.5	10.1	6.4	10.8	6.4
	35.0	8.0	6.0	8.1	6.1	8.8	6.1	9.0	6.4	9.4	6.4	10.0	6.4	10.7	6.3
	37.5	7.9	5.9	8.0	6.1	8.7	6.0	9.0	6.4	9.3	6.4	9.9	6.4	10.6	6.3
	40.0	7.8	5.9	7.9	6.0	8.6	6.0	8.9	6.4	9.2	6.4	9.8	6.3	10.5	6.3
	43.0	7.7	5.8	7.8	5.9	8.4	5.9	8.7	6.3	9.1	6.3	9.7	6.3	10.4	6.2

kcal/h=kW x 860 , BTU/h = kW x 3,412

4. Cooling [Ceiling cassette (2-way flow type)]

PLFY-P-VLMD-E

CA:Capacity(kW) , SHC:Sensible Heat Capacity(kW)

Model size (Rated kW)	Outdoor air temp. °C D.B.	Indoor air temp.													
		21.5°C D.B. 15°C W.B.		23°C D.B. 16°C W.B.		25°C D.B. 18°C W.B.		27°C D.B. 19°C W.B.		28°C D.B. 20°C W.B.		30°C D.B. 22°C W.B.		32°C D.B. 24°C W.B.	
		CA	SHC	CA	SHC	CA	SHC	CA	SHC	CA	SHC	CA	SHC	CA	SHC
100 (11.2)	20.0	10.6	7.6	10.9	7.8	11.7	7.8	12.0	8.3	12.4	8.2	13.2	8.1	14.1	8.0
	22.5	10.5	7.6	10.8	7.8	11.5	7.8	11.9	8.2	12.3	8.2	13.1	8.1	13.9	8.0
	25.0	10.4	7.5	10.6	7.7	11.4	7.7	11.8	8.1	12.2	8.1	13.0	8.0	13.8	7.9
	27.5	10.3	7.5	10.5	7.7	11.3	7.6	11.7	8.1	12.1	8.1	12.9	8.0	13.7	7.9
	30.0	10.2	7.4	10.4	7.6	11.2	7.6	11.5	8.0	11.9	8.0	12.7	7.9	13.6	7.8
	32.5	10.1	7.4	10.3	7.5	11.0	7.5	11.4	8.0	11.8	7.9	12.6	7.9	13.5	7.8
	35.0	9.9	7.3	10.1	7.5	10.9	7.5	11.2	7.9	11.7	7.9	12.5	7.8	13.3	7.7
	37.5	9.8	7.3	10.0	7.4	10.8	7.4	11.2	7.9	11.6	7.8	12.4	7.8	13.2	7.7
	40.0	9.7	7.2	9.9	7.4	10.6	7.3	11.0	7.8	11.4	7.8	12.2	7.7	13.1	7.7
43.0	9.6	7.2	9.7	7.3	10.5	7.3	10.9	7.7	11.3	7.7	12.1	7.7	12.9	7.6	
125 (14.0)	20.0	13.2	9.7	13.6	10.0	14.6	9.9	15.1	10.5	15.5	10.5	16.5	10.3	17.6	10.2
	22.5	13.1	9.7	13.5	9.9	14.4	9.9	14.9	10.4	15.4	10.4	16.4	10.3	17.4	10.2
	25.0	13.0	9.6	13.3	9.8	14.3	9.8	14.7	10.4	15.2	10.3	16.2	10.2	17.3	10.1
	27.5	12.8	9.5	13.2	9.8	14.1	9.7	14.6	10.3	15.1	10.3	16.1	10.2	17.1	10.0
	30.0	12.7	9.5	13.0	9.7	13.9	9.6	14.4	10.2	14.9	10.2	15.9	10.1	17.0	10.0
	32.5	12.6	9.4	12.8	9.6	13.8	9.6	14.3	10.2	14.8	10.1	15.8	10.0	16.8	9.9
	35.0	12.4	9.3	12.7	9.5	13.6	9.5	14.0	10.1	14.6	10.1	15.6	10.0	16.7	9.9
	37.5	12.3	9.3	12.5	9.4	13.5	9.4	14.0	10.0	14.4	10.0	15.5	9.9	16.5	9.8
	40.0	12.2	9.2	12.4	9.4	13.3	9.4	13.8	10.0	14.3	9.9	15.3	9.9	16.4	9.8
43.0	12.0	9.1	12.2	9.3	13.1	9.3	13.6	9.9	14.1	9.9	15.1	9.8	16.2	9.7	

kcal/h=kW x 860 , BTU/h = kW x 3,412

5. Cooling [Ceiling cassette (4-way flow type)]

5-1. Cooling capacity with PUHY,PURY-RP200-250YJM

PLFY-P-VCM-E

CA:Capacity(kW) , SHC:Sensible Heat Capacity(kW)

Model size (Rated kW)	Outdoor air temp. °C D.B.	Indoor air temp.													
		21.5°C D.B. 15°C W.B.		23°C D.B. 16°C W.B.		25°C D.B. 18°C W.B.		27°C D.B. 19°C W.B.		28°C D.B. 20°C W.B.		30°C D.B. 22°C W.B.		32°C D.B. 24°C W.B.	
		CA	SHC	CA	SHC	CA	SHC	CA	SHC	CA	SHC	CA	SHC	CA	SHC
20 (2.2)	20.0	2.1	1.8	2.2	1.8	2.3	1.8	2.4	2.0	2.5	2.0	2.6	1.9	2.8	1.9
	22.5	2.1	1.8	2.2	1.8	2.3	1.8	2.4	2.0	2.5	2.0	2.6	1.9	2.8	1.9
	25.0	2.1	1.8	2.2	1.8	2.3	1.8	2.4	2.0	2.4	1.9	2.6	1.9	2.7	1.9
	27.5	2.1	1.8	2.1	1.8	2.3	1.8	2.3	1.9	2.4	1.9	2.5	1.9	2.7	1.9
	30.0	2.0	1.8	2.1	1.8	2.2	1.8	2.3	1.9	2.3	1.9	2.5	1.9	2.6	1.9
	32.5	2.0	1.7	2.1	1.8	2.2	1.8	2.2	1.9	2.3	1.9	2.4	1.9	2.6	1.8
	35.0	2.0	1.7	2.0	1.8	2.1	1.8	2.2	1.9	2.3	1.9	2.4	1.8	2.5	1.8
	37.5	1.9	1.7	2.0	1.8	2.1	1.7	2.2	1.9	2.2	1.9	2.3	1.8	2.5	1.8
	40.0	1.9	1.7	2.0	1.8	2.1	1.7	2.1	1.9	2.2	1.8	2.3	1.8	2.4	1.8
43.0	1.8	1.7	1.9	1.7	2.0	1.7	2.1	1.8	2.1	1.8	2.2	1.8	2.3	1.8	
25 (2.8)	20.0	2.7	2.1	2.8	2.2	2.9	2.2	3.0	2.3	3.1	2.3	3.3	2.3	3.5	2.3
	22.5	2.7	2.1	2.8	2.2	2.9	2.2	3.0	2.3	3.1	2.3	3.3	2.3	3.5	2.3
	25.0	2.7	2.1	2.8	2.2	2.9	2.2	3.0	2.3	3.1	2.3	3.3	2.3	3.5	2.3
	27.5	2.7	2.1	2.7	2.2	2.9	2.2	3.0	2.3	3.0	2.3	3.2	2.3	3.4	2.2
	30.0	2.6	2.1	2.7	2.2	2.8	2.2	2.9	2.3	3.0	2.3	3.2	2.2	3.3	2.2
	32.5	2.6	2.1	2.6	2.2	2.8	2.1	2.9	2.3	2.9	2.3	3.1	2.2	3.3	2.2
	35.0	2.5	2.1	2.6	2.1	2.7	2.1	2.8	2.3	2.9	2.2	3.0	2.2	3.2	2.2
	37.5	2.5	2.0	2.5	2.1	2.7	2.1	2.8	2.2	2.8	2.2	3.0	2.2	3.1	2.1
	40.0	2.4	2.0	2.5	2.1	2.6	2.1	2.7	2.2	2.8	2.2	2.9	2.2	3.1	2.1
43.0	2.4	2.0	2.4	2.1	2.6	2.0	2.6	2.2	2.7	2.2	2.8	2.1	3.0	2.1	
32 (3.6)	20.0	3.4	2.6	3.5	2.7	3.8	2.7	3.9	2.8	4.0	2.8	4.3	2.8	4.6	2.8
	22.5	3.4	2.6	3.5	2.7	3.8	2.7	3.9	2.8	4.0	2.8	4.3	2.8	4.6	2.8
	25.0	3.4	2.6	3.5	2.7	3.8	2.7	3.9	2.8	4.0	2.8	4.2	2.8	4.5	2.7
	27.5	3.4	2.6	3.5	2.7	3.7	2.6	3.8	2.8	3.9	2.8	4.1	2.7	4.4	2.7
	30.0	3.3	2.6	3.4	2.6	3.6	2.6	3.7	2.8	3.8	2.7	4.1	2.7	4.3	2.7
	32.5	3.3	2.5	3.4	2.6	3.6	2.6	3.7	2.7	3.8	2.7	4.0	2.7	4.2	2.6
	35.0	3.2	2.5	3.3	2.6	3.5	2.6	3.6	2.7	3.7	2.7	3.9	2.6	4.1	2.6
	37.5	3.2	2.5	3.3	2.6	3.4	2.5	3.5	2.7	3.6	2.7	3.8	2.6	4.0	2.6
	40.0	3.1	2.4	3.2	2.5	3.4	2.5	3.5	2.7	3.6	2.6	3.7	2.6	3.9	2.5
43.0	3.0	2.4	3.1	2.5	3.3	2.5	3.4	2.6	3.5	2.6	3.6	2.5	3.8	2.5	
40 (4.5)	20.0	4.3	3.0	4.4	3.1	4.7	3.1	4.9	3.3	5.0	3.3	5.3	3.2	5.7	3.2
	22.5	4.3	3.0	4.4	3.1	4.7	3.1	4.9	3.3	5.0	3.3	5.3	3.2	5.7	3.2
	25.0	4.3	3.0	4.4	3.1	4.7	3.1	4.9	3.3	5.0	3.2	5.3	3.2	5.6	3.2
	27.5	4.3	3.0	4.4	3.1	4.6	3.1	4.8	3.2	4.9	3.2	5.2	3.2	5.5	3.1
	30.0	4.2	3.0	4.3	3.1	4.6	3.0	4.7	3.2	4.8	3.2	5.1	3.1	5.4	3.1
	32.5	4.1	3.0	4.2	3.0	4.5	3.0	4.6	3.2	4.7	3.1	5.0	3.1	5.3	3.0
	35.0	4.0	2.9	4.1	3.0	4.4	3.0	4.5	3.1	4.6	3.1	4.9	3.0	5.2	3.0
	37.5	4.0	2.9	4.1	3.0	4.3	2.9	4.4	3.1	4.5	3.1	4.8	3.0	5.0	2.9
	40.0	3.9	2.8	4.0	2.9	4.2	2.9	4.3	3.0	4.4	3.0	4.7	3.0	4.9	2.9
43.0	3.8	2.8	3.9	2.9	4.1	2.8	4.2	3.0	4.3	3.0	4.5	2.9	4.8	2.9	

kcal/h=kW x 860 , BTU/h = kW x 3,412

5. Cooling [Ceiling cassette (4-way flow type)]

PLFY-P-VBM-E

CA:Capacity(kW) , SHC:Sensible Heat Capacity(kW)

Model size (Rated kW)	Outdoor air temp.	Indoor air temp.													
		21.5°C D.B. 15°C W.B.		23°C D.B. 16°C W.B.		25°C D.B. 18°C W.B.		27°C D.B. 19°C W.B.		28°C D.B. 20°C W.B.		30°C D.B. 22°C W.B.		32°C D.B. 24°C W.B.	
		°C D.B.	CA	SHC	CA	SHC	CA	SHC	CA	SHC	CA	SHC	CA	SHC	CA
32 (3.6)	20.0	3.4	2.8	3.5	2.9	3.8	2.9	3.9	3.1	4.0	3.1	4.3	3.1	4.6	3.0
	22.5	3.4	2.8	3.5	2.9	3.8	2.9	3.9	3.1	4.0	3.1	4.3	3.1	4.6	3.0
	25.0	3.4	2.8	3.5	2.9	3.8	2.9	3.9	3.1	4.0	3.1	4.2	3.0	4.5	3.0
	27.5	3.4	2.8	3.5	2.9	3.7	2.9	3.8	3.1	3.9	3.1	4.1	3.0	4.4	3.0
	30.0	3.3	2.8	3.4	2.9	3.6	2.9	3.7	3.1	3.8	3.0	4.1	3.0	4.3	3.0
	32.5	3.3	2.8	3.4	2.9	3.6	2.8	3.7	3.0	3.8	3.0	4.0	3.0	4.2	2.9
	35.0	3.2	2.7	3.3	2.8	3.5	2.8	3.6	3.0	3.7	3.0	3.9	2.9	4.1	2.9
	37.5	3.2	2.7	3.3	2.8	3.4	2.8	3.5	3.0	3.6	3.0	3.8	2.9	4.0	2.9
	40.0	3.1	2.7	3.2	2.8	3.4	2.8	3.5	3.0	3.6	2.9	3.7	2.9	3.9	2.8
43.0	3.0	2.7	3.1	2.8	3.3	2.7	3.4	2.9	3.5	2.9	3.6	2.8	3.8	2.8	
40 (4.5)	20.0	4.3	3.5	4.4	3.6	4.7	3.6	4.9	3.8	5.0	3.8	5.3	3.7	5.7	3.7
	22.5	4.3	3.5	4.4	3.6	4.7	3.6	4.9	3.8	5.0	3.8	5.3	3.7	5.7	3.7
	25.0	4.3	3.5	4.4	3.6	4.7	3.6	4.9	3.8	5.0	3.8	5.3	3.7	5.6	3.6
	27.5	4.3	3.4	4.4	3.6	4.6	3.5	4.8	3.7	4.9	3.7	5.2	3.7	5.5	3.6
	30.0	4.2	3.4	4.3	3.5	4.6	3.5	4.7	3.7	4.8	3.7	5.1	3.6	5.4	3.6
	32.5	4.1	3.4	4.2	3.5	4.5	3.4	4.6	3.7	4.7	3.6	5.0	3.6	5.3	3.5
	35.0	4.0	3.3	4.1	3.4	4.4	3.4	4.5	3.6	4.6	3.6	4.9	3.6	5.2	3.5
	37.5	4.0	3.3	4.1	3.4	4.3	3.4	4.4	3.6	4.5	3.6	4.8	3.5	5.0	3.5
	40.0	3.9	3.3	4.0	3.4	4.2	3.3	4.3	3.6	4.4	3.5	4.7	3.5	4.9	3.4
43.0	3.8	3.2	3.9	3.3	4.1	3.3	4.2	3.5	4.3	3.5	4.5	3.4	4.8	3.4	
50 (5.6)	20.0	5.3	4.0	5.5	4.1	5.9	4.1	6.1	4.3	6.2	4.3	6.6	4.3	7.1	4.2
	22.5	5.3	4.0	5.5	4.1	5.9	4.1	6.1	4.3	6.2	4.3	6.6	4.3	7.1	4.2
	25.0	5.3	4.0	5.5	4.1	5.9	4.1	6.0	4.3	6.2	4.3	6.6	4.2	7.0	4.2
	27.5	5.3	4.0	5.5	4.1	5.8	4.0	5.9	4.3	6.1	4.2	6.4	4.2	6.8	4.1
	30.0	5.2	3.9	5.4	4.0	5.7	4.0	5.8	4.2	6.0	4.2	6.3	4.1	6.7	4.1
	32.5	5.1	3.9	5.3	4.0	5.6	4.0	5.7	4.2	5.9	4.2	6.2	4.1	6.6	4.0
	35.0	5.0	3.8	5.2	4.0	5.5	3.9	5.6	4.1	5.8	4.1	6.1	4.0	6.4	4.0
	37.5	4.9	3.8	5.1	3.9	5.4	3.9	5.5	4.1	5.6	4.1	5.9	4.0	6.3	3.9
	40.0	4.8	3.7	5.0	3.9	5.3	3.8	5.4	4.1	5.5	4.0	5.8	3.9	6.1	3.9
43.0	4.7	3.7	4.8	3.8	5.1	3.8	5.3	4.0	5.4	4.0	5.6	3.9	6.0	3.8	
63 (7.1)	20.0	6.7	4.9	7.0	5.1	7.5	5.0	7.7	5.3	7.9	5.3	8.4	5.2	9.0	5.2
	22.5	6.7	4.9	7.0	5.1	7.5	5.0	7.7	5.3	7.9	5.3	8.4	5.2	9.0	5.2
	25.0	6.7	4.9	7.0	5.1	7.5	5.0	7.7	5.3	7.9	5.3	8.3	5.2	8.8	5.1
	27.5	6.7	4.9	6.9	5.0	7.3	5.0	7.5	5.2	7.7	5.2	8.1	5.1	8.7	5.0
	30.0	6.6	4.8	6.8	5.0	7.2	4.9	7.4	5.2	7.6	5.1	8.0	5.0	8.5	5.0
	32.5	6.5	4.8	6.7	4.9	7.1	4.8	7.2	5.1	7.4	5.1	7.8	5.0	8.3	4.9
	35.0	6.4	4.7	6.5	4.8	6.9	4.8	7.1	5.0	7.3	5.0	7.7	4.9	8.1	4.8
	37.5	6.2	4.7	6.4	4.8	6.8	4.7	7.0	5.0	7.2	5.0	7.5	4.9	8.0	4.8
	40.0	6.1	4.6	6.3	4.7	6.7	4.7	6.8	4.9	7.0	4.9	7.4	4.8	7.8	4.7
43.0	6.0	4.5	6.1	4.7	6.5	4.6	6.7	4.9	6.9	4.8	7.2	4.7	7.6	4.7	
80 (9.0)	20.0	8.6	6.1	8.9	6.3	9.5	6.3	9.7	6.6	10.0	6.6	10.6	6.5	11.4	6.4
	22.5	8.6	6.1	8.9	6.3	9.5	6.3	9.7	6.6	10.0	6.6	10.6	6.5	11.4	6.4
	25.0	8.6	6.1	8.9	6.3	9.5	6.3	9.7	6.6	10.0	6.5	10.5	6.4	11.2	6.3
	27.5	8.5	6.1	8.8	6.3	9.3	6.2	9.5	6.5	9.8	6.4	10.3	6.3	11.0	6.2
	30.0	8.4	6.0	8.6	6.2	9.1	6.1	9.4	6.4	9.6	6.4	10.1	6.3	10.8	6.2
	32.5	8.2	5.9	8.5	6.1	8.9	6.0	9.2	6.3	9.4	6.3	9.9	6.2	10.5	6.1
	35.0	8.1	5.9	8.3	6.0	8.8	5.9	9.0	6.3	9.2	6.2	9.7	6.1	10.3	6.0
	37.5	7.9	5.8	8.1	5.9	8.6	5.9	8.8	6.2	9.1	6.1	9.5	6.0	10.1	5.9
	40.0	7.7	5.7	8.0	5.9	8.4	5.8	8.7	6.1	8.9	6.1	9.3	5.9	9.9	5.8
43.0	7.6	5.6	7.8	5.8	8.2	5.7	8.5	6.0	8.7	6.0	9.1	5.8	9.6	5.7	
100 (11.2)	20.0	10.6	7.6	11.0	7.9	11.8	7.8	12.1	8.2	12.5	8.2	13.2	8.1	14.2	8.0
	22.5	10.6	7.6	11.0	7.9	11.8	7.8	12.1	8.2	12.5	8.2	13.2	8.1	14.2	8.0
	25.0	10.6	7.6	11.0	7.9	11.8	7.8	12.1	8.2	12.4	8.2	13.1	8.0	13.9	7.9
	27.5	10.6	7.6	10.9	7.8	11.6	7.7	11.9	8.1	12.2	8.1	12.9	7.9	13.7	7.8
	30.0	10.4	7.5	10.7	7.7	11.3	7.6	11.6	8.0	12.0	8.0	12.6	7.8	13.4	7.7
	32.5	10.2	7.4	10.5	7.6	11.1	7.5	11.4	7.9	11.7	7.9	12.4	7.7	13.1	7.6
	35.0	10.0	7.3	10.3	7.5	10.9	7.4	11.2	7.8	11.5	7.8	12.1	7.6	12.8	7.5
	37.5	9.8	7.2	10.1	7.4	10.7	7.3	11.0	7.7	11.3	7.7	11.9	7.5	12.6	7.4
	40.0	9.6	7.1	9.9	7.3	10.5	7.3	10.8	7.7	11.1	7.6	11.6	7.4	12.3	7.3
43.0	9.4	7.0	9.7	7.2	10.2	7.1	10.5	7.5	10.8	7.5	11.3	7.3	12.0	7.2	
125 (14.0)	20.0	13.3	9.3	13.8	9.6	14.7	9.5	15.2	10.0	15.6	9.9	16.6	9.8	17.7	9.7
	22.5	13.3	9.3	13.8	9.6	14.7	9.5	15.2	10.0	15.6	9.9	16.6	9.8	17.7	9.7
	25.0	13.3	9.3	13.8	9.6	14.7	9.5	15.1	10.0	15.5	9.9	16.4	9.7	17.4	9.6
	27.5	13.3	9.3	13.6	9.5	14.4	9.4	14.8	9.9	15.2	9.8	16.1	9.6	17.1	9.5
	30.0	13.0	9.2	13.4	9.4	14.2	9.3	14.6	9.7	14.9	9.6	15.8	9.5	16.7	9.3
	32.5	12.8	9.0	13.2	9.3	13.9	9.2	14.3	9.6	14.7	9.5	15.4	9.3	16.4	9.2
	35.0	12.5	8.9	12.9	9.1	13.7	9.0	14.0	9.5	14.4	9.4	15.1	9.2	16.0	9.1
	37.5	12.3	8.8	12.7	9.0	13.4	8.9	13.8	9.4	14.1	9.3	14.8	9.1	15.7	8.9
	40.0	12.1	8.7	12.4	8.9	13.1	8.8	13.5	9.2	13.8	9.2	14.5	9.0	15.4	8.8
43.0	11.8	8.5	12.1	8.7	12.8	8.6	13.2	9.1	13.5	9.0	14.1	8.8	15.0	8.7	

kcal/h=kW x 860 , BTU/h = kW x 3,412

5. Cooling [Ceiling cassette (4-way flow type)]

5-2. Cooling capacity with PUHY-RP300-400Y(S)JM,PURY-RP300YJM

PLFY-P-VCM-E

CA:Capacity(kW) , SHC:Sensible Heat Capacity(kW)

Model size (Rated kW)	Outdoor air temp. °C D.B.	Indoor air temp.													
		21.5°C D.B. 15°C W.B.		23°C D.B. 16°C W.B.		25°C D.B. 18°C W.B.		27°C D.B. 19°C W.B.		28°C D.B. 20°C W.B.		30°C D.B. 22°C W.B.		32°C D.B. 24°C W.B.	
		CA	SHC	CA	SHC	CA	SHC	CA	SHC	CA	SHC	CA	SHC	CA	SHC
20 (2.2)	20.0	2.1	1.8	2.2	1.9	2.4	1.9	2.5	2.0	2.5	2.0	2.7	2.0	2.9	1.9
	22.5	2.1	1.8	2.2	1.9	2.3	1.8	2.4	2.0	2.5	2.0	2.6	1.9	2.8	1.9
	25.0	2.1	1.8	2.2	1.8	2.3	1.8	2.4	2.0	2.4	1.9	2.6	1.9	2.8	1.9
	27.5	2.1	1.8	2.1	1.8	2.3	1.8	2.3	1.9	2.4	1.9	2.5	1.9	2.7	1.9
	30.0	2.0	1.7	2.1	1.8	2.2	1.8	2.3	1.9	2.4	1.9	2.5	1.9	2.6	1.9
	32.5	2.0	1.7	2.0	1.8	2.2	1.8	2.2	1.9	2.3	1.9	2.4	1.9	2.6	1.8
	35.0	2.0	1.7	2.0	1.8	2.1	1.8	2.2	1.9	2.3	1.9	2.4	1.9	2.5	1.8
	37.5	1.9	1.7	2.0	1.8	2.1	1.7	2.1	1.9	2.2	1.9	2.3	1.8	2.5	1.8
	40.0	1.9	1.7	1.9	1.7	2.0	1.7	2.1	1.9	2.2	1.8	2.3	1.8	2.4	1.8
43.0	1.9	1.7	1.9	1.7	2.0	1.7	2.0	1.8	2.1	1.8	2.2	1.8	2.4	1.8	
25 (2.8)	20.0	2.7	2.2	2.8	2.2	3.0	2.2	3.1	2.4	3.2	2.4	3.4	2.3	3.6	2.3
	22.5	2.7	2.2	2.8	2.2	3.0	2.2	3.1	2.4	3.2	2.4	3.4	2.3	3.6	2.3
	25.0	2.7	2.1	2.7	2.2	2.9	2.2	3.0	2.3	3.1	2.3	3.3	2.3	3.5	2.3
	27.5	2.6	2.1	2.7	2.2	2.9	2.2	3.0	2.3	3.1	2.3	3.2	2.3	3.4	2.2
	30.0	2.6	2.1	2.6	2.2	2.8	2.1	2.9	2.3	3.0	2.3	3.2	2.3	3.4	2.2
	32.5	2.5	2.1	2.6	2.1	2.8	2.1	2.8	2.3	2.9	2.3	3.1	2.2	3.3	2.2
	35.0	2.5	2.1	2.5	2.1	2.7	2.1	2.8	2.3	2.9	2.2	3.0	2.2	3.2	2.2
	37.5	2.5	2.0	2.5	2.1	2.6	2.1	2.7	2.2	2.8	2.2	3.0	2.2	3.2	2.2
	40.0	2.4	2.0	2.4	2.1	2.6	2.1	2.7	2.2	2.8	2.2	2.9	2.2	3.1	2.1
43.0	2.4	2.0	2.4	2.0	2.5	2.0	2.6	2.2	2.7	2.2	2.8	2.1	3.0	2.1	
32 (3.6)	20.0	3.5	2.6	3.6	2.7	3.9	2.7	4.0	2.9	4.2	2.9	4.4	2.8	4.7	2.8
	22.5	3.5	2.6	3.6	2.7	3.8	2.7	4.0	2.9	4.1	2.8	4.3	2.8	4.6	2.8
	25.0	3.4	2.6	3.5	2.7	3.8	2.7	3.9	2.8	4.0	2.8	4.2	2.8	4.5	2.7
	27.5	3.4	2.6	3.5	2.6	3.7	2.6	3.8	2.8	3.9	2.8	4.2	2.7	4.4	2.7
	30.0	3.3	2.6	3.4	2.6	3.6	2.6	3.7	2.8	3.8	2.7	4.1	2.7	4.3	2.7
	32.5	3.3	2.5	3.3	2.6	3.5	2.6	3.7	2.7	3.8	2.7	4.0	2.7	4.2	2.6
	35.0	3.2	2.5	3.3	2.6	3.5	2.5	3.6	2.7	3.7	2.7	3.9	2.7	4.2	2.6
	37.5	3.2	2.5	3.2	2.5	3.4	2.5	3.5	2.7	3.6	2.7	3.8	2.6	4.1	2.6
	40.0	3.1	2.4	3.1	2.5	3.3	2.5	3.4	2.6	3.5	2.6	3.8	2.6	4.0	2.6
43.0	3.0	2.4	3.0	2.5	3.2	2.4	3.3	2.6	3.4	2.6	3.7	2.6	3.9	2.5	
40 (4.5)	20.0	4.4	3.1	4.5	3.2	4.9	3.2	5.0	3.4	5.2	3.3	5.5	3.3	5.8	3.2
	22.5	4.4	3.1	4.5	3.2	4.8	3.1	4.9	3.3	5.1	3.3	5.4	3.3	5.7	3.2
	25.0	4.3	3.1	4.4	3.1	4.7	3.1	4.9	3.3	5.0	3.3	5.3	3.2	5.6	3.2
	27.5	4.2	3.0	4.3	3.1	4.6	3.1	4.8	3.2	4.9	3.2	5.2	3.2	5.5	3.1
	30.0	4.1	3.0	4.2	3.0	4.5	3.0	4.7	3.2	4.8	3.2	5.1	3.1	5.4	3.1
	32.5	4.1	2.9	4.2	3.0	4.4	3.0	4.6	3.1	4.7	3.1	5.0	3.1	5.3	3.0
	35.0	4.0	2.9	4.1	3.0	4.3	2.9	4.5	3.1	4.6	3.1	4.9	3.0	5.2	3.0
	37.5	3.9	2.9	4.0	2.9	4.2	2.9	4.4	3.1	4.5	3.0	4.8	3.0	5.1	3.0
	40.0	3.9	2.8	3.9	2.9	4.2	2.9	4.3	3.0	4.4	3.0	4.7	3.0	5.0	2.9
43.0	3.8	2.8	3.8	2.8	4.0	2.8	4.2	3.0	4.3	3.0	4.6	2.9	4.8	2.9	

kcal/h=kW x 860 , BTU/h = kW x 3,412

5. Cooling [Ceiling cassette (4-way flow type)]

PLFY-P-VBM-E

CA:Capacity(kW) , SHC:Sensible Heat Capacity(kW)

Model size (Rated kW)	Outdoor air temp. °C D.B.	Indoor air temp.													
		21.5°C D.B. 15°C W.B.		23°C D.B. 16°C W.B.		25°C D.B. 18°C W.B.		27°C D.B. 19°C W.B.		28°C D.B. 20°C W.B.		30°C D.B. 22°C W.B.		32°C D.B. 24°C W.B.	
		CA	SHC	CA	SHC	CA	SHC	CA	SHC	CA	SHC	CA	SHC	CA	SHC
32 (3.6)	20.0	3.5	2.9	3.6	3.0	3.9	3.0	4.0	3.2	4.2	3.2	4.4	3.1	4.7	3.1
	22.5	3.5	2.9	3.6	3.0	3.8	2.9	4.0	3.1	4.1	3.1	4.3	3.1	4.6	3.0
	25.0	3.4	2.8	3.5	2.9	3.8	2.9	3.9	3.1	4.0	3.1	4.2	3.1	4.5	3.0
	27.5	3.4	2.8	3.5	2.9	3.7	2.9	3.8	3.1	3.9	3.1	4.2	3.0	4.4	3.0
	30.0	3.3	2.8	3.4	2.9	3.6	2.9	3.7	3.1	3.8	3.0	4.1	3.0	4.3	3.0
	32.5	3.3	2.8	3.3	2.8	3.5	2.8	3.7	3.0	3.8	3.0	4.0	3.0	4.2	2.9
	35.0	3.2	2.7	3.3	2.8	3.5	2.8	3.6	3.0	3.7	3.0	3.9	2.9	4.2	2.9
	37.5	3.2	2.7	3.2	2.8	3.4	2.8	3.5	3.0	3.6	3.0	3.8	2.9	4.1	2.9
	40.0	3.1	2.7	3.1	2.8	3.3	2.7	3.4	2.9	3.5	2.9	3.8	2.9	4.0	2.8
43.0	3.0	2.7	3.0	2.7	3.2	2.7	3.3	2.9	3.4	2.9	3.7	2.9	3.9	2.8	
40 (4.5)	20.0	4.4	3.5	4.5	3.6	4.9	3.6	5.0	3.9	5.2	3.8	5.5	3.8	5.8	3.7
	22.5	4.4	3.5	4.5	3.6	4.8	3.6	4.9	3.8	5.1	3.8	5.4	3.8	5.7	3.7
	25.0	4.3	3.5	4.4	3.6	4.7	3.5	4.9	3.8	5.0	3.8	5.3	3.7	5.6	3.7
	27.5	4.2	3.4	4.3	3.5	4.6	3.5	4.8	3.7	4.9	3.7	5.2	3.7	5.5	3.6
	30.0	4.1	3.4	4.2	3.5	4.5	3.5	4.7	3.7	4.8	3.7	5.1	3.6	5.4	3.6
	32.5	4.1	3.4	4.2	3.5	4.4	3.4	4.6	3.7	4.7	3.6	5.0	3.6	5.3	3.5
	35.0	4.0	3.3	4.1	3.4	4.3	3.4	4.5	3.6	4.6	3.6	4.9	3.6	5.2	3.5
	37.5	3.9	3.3	4.0	3.4	4.2	3.3	4.4	3.6	4.5	3.6	4.8	3.5	5.1	3.5
	40.0	3.9	3.3	3.9	3.3	4.2	3.3	4.3	3.6	4.4	3.5	4.7	3.5	5.0	3.4
43.0	3.8	3.2	3.8	3.3	4.0	3.3	4.2	3.5	4.3	3.5	4.6	3.4	4.8	3.4	
50 (5.6)	20.0	5.4	4.0	5.6	4.2	6.1	4.2	6.3	4.4	6.5	4.4	6.9	4.3	7.3	4.3
	22.5	5.4	4.0	5.6	4.2	6.0	4.1	6.2	4.4	6.3	4.4	6.7	4.3	7.1	4.2
	25.0	5.3	4.0	5.5	4.1	5.8	4.1	6.0	4.3	6.2	4.3	6.6	4.2	7.0	4.2
	27.5	5.3	4.0	5.4	4.1	5.7	4.0	5.9	4.3	6.1	4.3	6.5	4.2	6.9	4.1
	30.0	5.2	3.9	5.3	4.0	5.6	4.0	5.8	4.2	6.0	4.2	6.4	4.1	6.7	4.1
	32.5	5.1	3.9	5.2	4.0	5.5	3.9	5.7	4.2	5.9	4.2	6.2	4.1	6.6	4.0
	35.0	5.0	3.8	5.1	3.9	5.4	3.9	5.6	4.1	5.7	4.1	6.1	4.1	6.5	4.0
	37.5	4.9	3.8	5.0	3.9	5.3	3.8	5.5	4.1	5.6	4.1	6.0	4.0	6.3	3.9
	40.0	4.8	3.7	4.9	3.8	5.2	3.8	5.3	4.0	5.5	4.0	5.8	4.0	6.2	3.9
43.0	4.7	3.7	4.7	3.8	5.0	3.7	5.2	4.0	5.4	3.9	5.7	3.9	6.0	3.8	
63 (7.1)	20.0	6.9	5.0	7.1	5.1	7.7	5.1	7.9	5.4	8.2	5.4	8.7	5.3	9.2	5.2
	22.5	6.9	5.0	7.1	5.1	7.6	5.1	7.8	5.4	8.0	5.3	8.5	5.3	9.1	5.2
	25.0	6.8	4.9	7.0	5.0	7.4	5.0	7.7	5.3	7.9	5.3	8.4	5.2	8.9	5.1
	27.5	6.7	4.9	6.8	5.0	7.3	4.9	7.5	5.2	7.7	5.2	8.2	5.1	8.7	5.1
	30.0	6.5	4.8	6.7	4.9	7.1	4.9	7.4	5.2	7.6	5.1	8.1	5.1	8.5	5.0
	32.5	6.4	4.8	6.6	4.9	7.0	4.8	7.2	5.1	7.4	5.1	7.9	5.0	8.4	4.9
	35.0	6.3	4.7	6.4	4.8	6.8	4.8	7.1	5.0	7.3	5.0	7.7	4.9	8.2	4.9
	37.5	6.2	4.6	6.3	4.7	6.7	4.7	6.9	5.0	7.1	4.9	7.6	4.9	8.0	4.8
	40.0	6.1	4.6	6.2	4.7	6.6	4.6	6.8	4.9	7.0	4.9	7.4	4.8	7.8	4.7
43.0	6.0	4.5	6.0	4.6	6.4	4.5	6.6	4.8	6.8	4.8	7.2	4.7	7.6	4.7	
80 (9.0)	20.0	8.7	6.2	9.0	6.4	9.7	6.4	10.1	6.7	10.4	6.7	11.0	6.6	11.7	6.5
	22.5	8.7	6.2	9.0	6.4	9.6	6.3	9.9	6.7	10.2	6.6	10.8	6.5	11.5	6.4
	25.0	8.6	6.1	8.8	6.3	9.4	6.2	9.7	6.6	10.0	6.5	10.6	6.5	11.3	6.4
	27.5	8.4	6.1	8.6	6.2	9.2	6.1	9.5	6.5	9.8	6.5	10.4	6.4	11.0	6.3
	30.0	8.3	6.0	8.5	6.1	9.0	6.1	9.3	6.4	9.6	6.4	10.2	6.3	10.8	6.2
	32.5	8.2	5.9	8.3	6.0	8.9	6.0	9.1	6.3	9.4	6.3	10.0	6.2	10.6	6.1
	35.0	8.0	5.8	8.1	5.9	8.7	5.9	9.0	6.3	9.2	6.2	9.8	6.1	10.4	6.0
	37.5	7.9	5.8	8.0	5.9	8.5	5.8	8.8	6.2	9.0	6.1	9.6	6.0	10.2	5.9
	40.0	7.7	5.7	7.8	5.8	8.3	5.7	8.6	6.1	8.8	6.0	9.4	6.0	9.9	5.9
43.0	7.6	5.6	7.6	5.7	8.1	5.6	8.4	6.0	8.6	5.9	9.1	5.9	9.7	5.8	
100 (11.2)	20.0	10.9	7.8	11.3	8.0	12.1	8.0	12.5	8.4	12.9	8.4	13.7	8.3	14.5	8.2
	22.5	10.8	7.8	11.2	8.0	11.9	7.9	12.3	8.3	12.7	8.3	13.5	8.2	14.3	8.1
	25.0	10.7	7.7	11.0	7.9	11.7	7.8	12.1	8.2	12.5	8.2	13.2	8.1	14.0	8.0
	27.5	10.5	7.6	10.8	7.7	11.5	7.7	11.8	8.1	12.2	8.1	13.0	8.0	13.7	7.9
	30.0	10.3	7.5	10.6	7.6	11.2	7.6	11.6	8.0	12.0	8.0	12.7	7.9	13.5	7.8
	32.5	10.2	7.4	10.3	7.5	11.0	7.5	11.4	7.9	11.7	7.9	12.4	7.8	13.2	7.6
	35.0	10.0	7.3	10.1	7.4	10.8	7.4	11.2	7.8	11.5	7.8	12.2	7.7	12.9	7.5
	37.5	9.8	7.2	9.9	7.3	10.6	7.3	10.9	7.7	11.2	7.7	11.9	7.6	12.6	7.5
	40.0	9.6	7.1	9.7	7.2	10.3	7.2	10.7	7.6	11.0	7.6	11.7	7.5	12.4	7.4
43.0	9.4	7.0	9.5	7.1	10.1	7.1	10.4	7.5	10.7	7.4	11.4	7.4	12.1	7.2	
125 (14.0)	20.0	13.6	9.5	14.1	9.7	15.1	9.7	15.7	10.2	16.2	10.2	17.2	10.1	18.2	9.9
	22.5	13.6	9.5	14.0	9.7	14.9	9.6	15.4	10.1	15.9	10.1	16.8	9.9	17.8	9.8
	25.0	13.3	9.3	13.7	9.5	14.6	9.5	15.1	10.0	15.6	9.9	16.5	9.8	17.5	9.6
	27.5	13.1	9.2	13.5	9.4	14.3	9.4	14.8	9.8	15.3	9.8	16.2	9.7	17.2	9.5
	30.0	12.9	9.1	13.2	9.3	14.1	9.2	14.5	9.7	15.0	9.7	15.9	9.5	16.8	9.4
	32.5	12.7	9.0	12.9	9.1	13.8	9.1	14.2	9.6	14.7	9.5	15.6	9.4	16.5	9.2
	35.0	12.5	8.9	12.7	9.0	13.5	8.9	14.0	9.5	14.4	9.4	15.2	9.3	16.2	9.1
	37.5	12.3	8.8	12.4	8.9	13.2	8.8	13.6	9.3	14.1	9.3	14.9	9.1	15.8	9.0
	40.0	12.0	8.7	12.2	8.8	12.9	8.7	13.3	9.2	13.8	9.1	14.6	9.0	15.5	8.9
43.0	11.8	8.5	11.8	8.6	12.6	8.5	13.0	9.0	13.4	9.0	14.2	8.8	15.1	8.7	

kcal/h=kW x 860 , BTU/h = kW x 3,412

5. Cooling [Ceiling cassette (4-way flow type)]

5-3. Cooling capacity with PUHY-RP450-650YSJM

PLFY-P-VCM-E

CA:Capacity(kW) , SHC:Sensible Heat Capacity(kW)

Model size (Rated kW)	Outdoor air temp. °C D.B.	Indoor air temp.													
		21.5°C D.B. 15°C W.B.		23°C D.B. 16°C W.B.		25°C D.B. 18°C W.B.		27°C D.B. 19°C W.B.		28°C D.B. 20°C W.B.		30°C D.B. 22°C W.B.		32°C D.B. 24°C W.B.	
		CA	SHC	CA	SHC	CA	SHC	CA	SHC	CA	SHC	CA	SHC	CA	SHC
20 (2.2)	20.0	2.1	1.8	2.1	1.8	2.3	1.8	2.4	2.0	2.4	1.9	2.6	1.9	2.8	1.9
	22.5	2.1	1.8	2.1	1.8	2.3	1.8	2.3	1.9	2.4	1.9	2.6	1.9	2.7	1.9
	25.0	2.0	1.8	2.1	1.8	2.2	1.8	2.3	1.9	2.4	1.9	2.5	1.9	2.7	1.9
	27.5	2.0	1.7	2.1	1.8	2.2	1.8	2.3	1.9	2.4	1.9	2.5	1.9	2.7	1.9
	30.0	2.0	1.7	2.0	1.8	2.2	1.8	2.3	1.9	2.3	1.9	2.5	1.9	2.7	1.9
	32.5	2.0	1.7	2.0	1.8	2.2	1.8	2.2	1.9	2.3	1.9	2.5	1.9	2.6	1.9
	35.0	2.0	1.7	2.0	1.8	2.1	1.8	2.2	1.9	2.3	1.9	2.5	1.9	2.6	1.9
	37.5	1.9	1.7	2.0	1.8	2.1	1.8	2.2	1.9	2.3	1.9	2.4	1.9	2.6	1.8
	40.0	1.9	1.7	1.9	1.7	2.1	1.7	2.2	1.9	2.2	1.9	2.4	1.9	2.6	1.8
43.0	1.9	1.7	1.9	1.7	2.1	1.7	2.1	1.9	2.2	1.9	2.4	1.8	2.5	1.8	
25 (2.8)	20.0	2.6	2.1	2.7	2.2	2.9	2.2	3.0	2.3	3.1	2.3	3.3	2.3	3.5	2.3
	22.5	2.6	2.1	2.7	2.2	2.9	2.2	3.0	2.3	3.1	2.3	3.3	2.3	3.5	2.3
	25.0	2.6	2.1	2.7	2.2	2.9	2.2	2.9	2.3	3.0	2.3	3.2	2.3	3.5	2.3
	27.5	2.6	2.1	2.6	2.2	2.8	2.1	2.9	2.3	3.0	2.3	3.2	2.3	3.4	2.2
	30.0	2.5	2.1	2.6	2.1	2.8	2.1	2.9	2.3	3.0	2.3	3.2	2.3	3.4	2.2
	32.5	2.5	2.1	2.6	2.1	2.8	2.1	2.9	2.3	3.0	2.3	3.2	2.2	3.4	2.2
	35.0	2.5	2.1	2.5	2.1	2.7	2.1	2.8	2.3	2.9	2.3	3.1	2.2	3.3	2.2
	37.5	2.5	2.0	2.5	2.1	2.7	2.1	2.8	2.2	2.9	2.2	3.1	2.2	3.3	2.2
	40.0	2.4	2.0	2.5	2.1	2.7	2.1	2.8	2.2	2.9	2.2	3.1	2.2	3.3	2.2
43.0	2.4	2.0	2.4	2.1	2.6	2.1	2.7	2.2	2.8	2.2	3.0	2.2	3.2	2.2	
32 (3.6)	20.0	3.4	2.6	3.5	2.7	3.7	2.7	3.9	2.8	4.0	2.8	4.3	2.8	4.5	2.7
	22.5	3.4	2.6	3.5	2.7	3.7	2.6	3.8	2.8	4.0	2.8	4.2	2.8	4.5	2.7
	25.0	3.3	2.6	3.4	2.6	3.7	2.6	3.8	2.8	3.9	2.8	4.2	2.7	4.4	2.7
	27.5	3.3	2.5	3.4	2.6	3.6	2.6	3.8	2.8	3.9	2.8	4.1	2.7	4.4	2.7
	30.0	3.3	2.5	3.3	2.6	3.6	2.6	3.7	2.8	3.8	2.7	4.1	2.7	4.4	2.7
	32.5	3.2	2.5	3.3	2.6	3.5	2.6	3.7	2.7	3.8	2.7	4.1	2.7	4.3	2.7
	35.0	3.2	2.5	3.3	2.6	3.5	2.6	3.6	2.7	3.8	2.7	4.0	2.7	4.3	2.7
	37.5	3.2	2.5	3.2	2.5	3.5	2.5	3.6	2.7	3.7	2.7	4.0	2.7	4.2	2.6
	40.0	3.1	2.5	3.2	2.5	3.4	2.5	3.5	2.7	3.7	2.7	3.9	2.7	4.2	2.6
43.0	3.1	2.4	3.1	2.5	3.4	2.5	3.5	2.7	3.6	2.7	3.9	2.6	4.2	2.6	
40 (4.5)	20.0	4.3	3.0	4.4	3.1	4.7	3.1	4.8	3.3	5.0	3.3	5.3	3.2	5.7	3.2
	22.5	4.2	3.0	4.3	3.1	4.6	3.1	4.8	3.2	4.9	3.2	5.3	3.2	5.6	3.2
	25.0	4.2	3.0	4.3	3.1	4.6	3.1	4.7	3.2	4.9	3.2	5.2	3.2	5.6	3.1
	27.5	4.1	3.0	4.2	3.0	4.5	3.0	4.7	3.2	4.8	3.2	5.2	3.2	5.5	3.1
	30.0	4.1	2.9	4.2	3.0	4.5	3.0	4.6	3.2	4.8	3.2	5.1	3.1	5.5	3.1
	32.5	4.0	2.9	4.1	3.0	4.4	3.0	4.6	3.2	4.7	3.1	5.1	3.1	5.4	3.1
	35.0	4.0	2.9	4.1	3.0	4.4	3.0	4.5	3.1	4.7	3.1	5.0	3.1	5.4	3.1
	37.5	4.0	2.9	4.0	2.9	4.3	2.9	4.5	3.1	4.6	3.1	5.0	3.1	5.3	3.0
	40.0	3.9	2.9	4.0	2.9	4.3	2.9	4.4	3.1	4.6	3.1	4.9	3.1	5.3	3.0
43.0	3.9	2.8	3.9	2.9	4.2	2.9	4.4	3.1	4.5	3.0	4.9	3.0	5.2	3.0	

kcal/h=kW x 860 , BTU/h = kW x 3,412

5. Cooling [Ceiling cassette (4-way flow type)]

PLFY-P-VBM-E

CA:Capacity(kW) , SHC:Sensible Heat Capacity(kW)

Model size (Rated kW)	Outdoor air temp. °C D.B.	Indoor air temp.													
		21.5°C D.B. 15°C W.B.		23°C D.B. 16°C W.B.		25°C D.B. 18°C W.B.		27°C D.B. 19°C W.B.		28°C D.B. 20°C W.B.		30°C D.B. 22°C W.B.		32°C D.B. 24°C W.B.	
		CA	SHC	CA	SHC	CA	SHC	CA	SHC	CA	SHC	CA	SHC	CA	SHC
32 (3.6)	20.0	3.4	2.8	3.5	2.9	3.7	2.9	3.9	3.1	4.0	3.1	4.3	3.1	4.5	3.0
	22.5	3.4	2.8	3.5	2.9	3.7	2.9	3.8	3.1	4.0	3.1	4.2	3.0	4.5	3.0
	25.0	3.3	2.8	3.4	2.9	3.7	2.9	3.8	3.1	3.9	3.1	4.2	3.0	4.4	3.0
	27.5	3.3	2.8	3.4	2.9	3.6	2.9	3.8	3.1	3.9	3.1	4.1	3.0	4.4	3.0
	30.0	3.3	2.8	3.3	2.9	3.6	2.8	3.7	3.0	3.8	3.0	4.1	3.0	4.4	3.0
	32.5	3.2	2.7	3.3	2.8	3.5	2.8	3.7	3.0	3.8	3.0	4.1	3.0	4.3	3.0
	35.0	3.2	2.7	3.3	2.8	3.5	2.8	3.6	3.0	3.8	3.0	4.0	3.0	4.3	2.9
	37.5	3.2	2.7	3.2	2.8	3.5	2.8	3.6	3.0	3.7	3.0	4.0	3.0	4.2	2.9
	40.0	3.1	2.7	3.2	2.8	3.4	2.8	3.5	3.0	3.7	3.0	3.9	3.0	4.2	2.9
43.0	3.1	2.7	3.1	2.8	3.4	2.8	3.5	3.0	3.6	3.0	3.9	2.9	4.2	2.9	
40 (4.5)	20.0	4.3	3.4	4.4	3.6	4.7	3.5	4.8	3.8	5.0	3.8	5.3	3.7	5.7	3.7
	22.5	4.2	3.4	4.3	3.5	4.6	3.5	4.8	3.8	4.9	3.7	5.3	3.7	5.6	3.6
	25.0	4.2	3.4	4.3	3.5	4.6	3.5	4.7	3.7	4.9	3.7	5.2	3.7	5.6	3.6
	27.5	4.1	3.4	4.2	3.5	4.5	3.5	4.7	3.7	4.8	3.7	5.2	3.7	5.5	3.6
	30.0	4.1	3.4	4.2	3.5	4.5	3.4	4.6	3.7	4.8	3.7	5.1	3.6	5.5	3.6
	32.5	4.0	3.3	4.1	3.4	4.4	3.4	4.6	3.7	4.7	3.7	5.1	3.6	5.4	3.6
	35.0	4.0	3.3	4.1	3.4	4.4	3.4	4.5	3.6	4.7	3.6	5.0	3.6	5.4	3.6
	37.5	4.0	3.3	4.0	3.4	4.3	3.4	4.5	3.6	4.6	3.6	5.0	3.6	5.3	3.6
	40.0	3.9	3.3	4.0	3.4	4.3	3.4	4.4	3.6	4.6	3.6	4.9	3.6	5.3	3.5
43.0	3.9	3.3	3.9	3.3	4.2	3.3	4.4	3.6	4.5	3.6	4.9	3.5	5.2	3.5	
50 (5.6)	20.0	5.3	4.0	5.5	4.1	5.8	4.1	6.0	4.3	6.2	4.3	6.6	4.3	7.0	4.2
	22.5	5.2	4.0	5.4	4.1	5.8	4.0	6.0	4.3	6.2	4.3	6.6	4.2	7.0	4.2
	25.0	5.2	3.9	5.3	4.0	5.7	4.0	5.9	4.3	6.1	4.2	6.5	4.2	6.9	4.2
	27.5	5.1	3.9	5.3	4.0	5.6	4.0	5.8	4.2	6.0	4.2	6.4	4.2	6.9	4.1
	30.0	5.1	3.9	5.2	4.0	5.6	4.0	5.8	4.2	6.0	4.2	6.4	4.2	6.8	4.1
	32.5	5.0	3.8	5.1	3.9	5.5	3.9	5.7	4.2	5.9	4.2	6.3	4.1	6.7	4.1
	35.0	5.0	3.8	5.1	3.9	5.4	3.9	5.6	4.1	5.8	4.1	6.2	4.1	6.7	4.1
	37.5	4.9	3.8	5.0	3.9	5.4	3.9	5.6	4.1	5.8	4.1	6.2	4.1	6.6	4.0
	40.0	4.9	3.8	4.9	3.9	5.3	3.8	5.5	4.1	5.7	4.1	6.1	4.1	6.5	4.0
43.0	4.8	3.7	4.9	3.8	5.2	3.8	5.4	4.1	5.6	4.1	6.0	4.0	6.5	4.0	
63 (7.1)	20.0	6.7	4.9	6.9	5.0	7.4	5.0	7.6	5.3	7.9	5.3	8.4	5.2	8.9	5.1
	22.5	6.6	4.9	6.8	5.0	7.3	5.0	7.6	5.3	7.8	5.2	8.3	5.2	8.8	5.1
	25.0	6.6	4.8	6.8	4.9	7.2	4.9	7.5	5.2	7.7	5.2	8.2	5.1	8.8	5.1
	27.5	6.5	4.8	6.7	4.9	7.2	4.9	7.4	5.2	7.6	5.2	8.2	5.1	8.7	5.0
	30.0	6.4	4.8	6.6	4.9	7.1	4.9	7.3	5.1	7.6	5.1	8.1	5.1	8.6	5.0
	32.5	6.4	4.7	6.5	4.8	7.0	4.8	7.2	5.1	7.5	5.1	8.0	5.0	8.5	5.0
	35.0	6.3	4.7	6.4	4.8	6.9	4.8	7.1	5.0	7.4	5.1	7.9	5.0	8.5	5.0
	37.5	6.2	4.7	6.3	4.8	6.8	4.7	7.1	5.0	7.3	5.0	7.8	5.0	8.4	4.9
	40.0	6.2	4.6	6.3	4.7	6.7	4.7	7.0	5.0	7.2	5.0	7.8	5.0	8.3	4.9
43.0	6.1	4.6	6.2	4.7	6.7	4.7	6.9	5.0	7.1	5.0	7.7	4.9	8.2	4.9	
80 (9.0)	20.0	8.5	6.1	8.8	6.2	9.4	6.2	9.7	6.6	10.0	6.5	10.6	6.5	11.3	6.4
	22.5	8.4	6.0	8.7	6.2	9.3	6.2	9.6	6.5	9.9	6.5	10.5	6.4	11.2	6.3
	25.0	8.3	6.0	8.6	6.1	9.2	6.1	9.5	6.5	9.8	6.4	10.4	6.4	11.1	6.3
	27.5	8.3	6.0	8.5	6.1	9.1	6.1	9.4	6.4	9.7	6.4	10.3	6.3	11.0	6.3
	30.0	8.2	5.9	8.4	6.0	9.0	6.0	9.3	6.4	9.6	6.4	10.2	6.3	10.9	6.2
	32.5	8.1	5.9	8.3	6.0	8.9	6.0	9.2	6.3	9.5	6.3	10.1	6.3	10.8	6.2
	35.0	8.0	5.8	8.1	5.9	8.8	5.9	9.0	6.3	9.4	6.3	10.0	6.2	10.7	6.2
	37.5	7.9	5.8	8.0	5.9	8.7	5.9	9.0	6.2	9.3	6.2	9.9	6.2	10.6	6.1
	40.0	7.8	5.7	7.9	5.8	8.6	5.8	8.9	6.2	9.2	6.2	9.8	6.1	10.5	6.1
43.0	7.7	5.7	7.8	5.8	8.4	5.8	8.7	6.1	9.1	6.1	9.7	6.1	10.4	6.0	
100 (11.2)	20.0	10.6	7.6	10.9	7.8	11.7	7.8	12.0	8.2	12.4	8.2	13.2	8.1	14.1	8.0
	22.5	10.5	7.6	10.8	7.8	11.5	7.7	11.9	8.2	12.3	8.1	13.1	8.0	13.9	7.9
	25.0	10.4	7.5	10.6	7.7	11.4	7.7	11.8	8.1	12.2	8.1	13.0	8.0	13.8	7.9
	27.5	10.3	7.5	10.5	7.6	11.3	7.6	11.7	8.0	12.1	8.0	12.9	7.9	13.7	7.8
	30.0	10.2	7.4	10.4	7.6	11.2	7.5	11.5	8.0	11.9	8.0	12.7	7.9	13.6	7.8
	32.5	10.1	7.3	10.3	7.5	11.0	7.5	11.4	7.9	11.8	7.9	12.6	7.8	13.5	7.7
	35.0	9.9	7.3	10.1	7.4	10.9	7.4	11.2	7.8	11.7	7.8	12.5	7.8	13.3	7.7
	37.5	9.8	7.2	10.0	7.4	10.8	7.4	11.2	7.8	11.6	7.8	12.4	7.7	13.2	7.7
	40.0	9.7	7.2	9.9	7.3	10.6	7.3	11.0	7.8	11.4	7.7	12.2	7.7	13.1	7.6
43.0	9.6	7.1	9.7	7.2	10.5	7.2	10.9	7.7	11.3	7.7	12.1	7.6	12.9	7.6	
125 (14.0)	20.0	13.2	9.3	13.6	9.5	14.6	9.5	15.1	10.0	15.5	9.9	16.5	9.8	17.6	9.7
	22.5	13.1	9.2	13.5	9.4	14.4	9.4	14.9	9.9	15.4	9.8	16.4	9.7	17.4	9.6
	25.0	13.0	9.1	13.3	9.3	14.3	9.3	14.7	9.8	15.2	9.8	16.2	9.7	17.3	9.5
	27.5	12.8	9.1	13.2	9.3	14.1	9.2	14.6	9.7	15.1	9.7	16.1	9.6	17.1	9.5
	30.0	12.7	9.0	13.0	9.2	13.9	9.2	14.4	9.7	14.9	9.6	15.9	9.5	17.0	9.4
	32.5	12.6	8.9	12.8	9.1	13.8	9.1	14.3	9.6	14.8	9.6	15.8	9.5	16.8	9.4
	35.0	12.4	8.9	12.7	9.0	13.6	9.0	14.0	9.5	14.6	9.5	15.6	9.4	16.7	9.3
	37.5	12.3	8.8	12.5	8.9	13.5	8.9	14.0	9.4	14.4	9.4	15.5	9.3	16.5	9.3
	40.0	12.2	8.7	12.4	8.9	13.3	8.9	13.8	9.4	14.3	9.3	15.3	9.3	16.4	9.2
43.0	12.0	8.6	12.2	8.8	13.1	8.8	13.6	9.3	14.1	9.3	15.1	9.2	16.2	9.1	

kcal/h=kW x 860 , BTU/h = kW x 3,412

5. Cooling [Ceiling cassette (4-way flow type)]

5-4. Cooling capacity with PUHY-RP700-800YSJM

PLFY-P-VCM-E

CA:Capacity(kW) , SHC:Sensible Heat Capacity(kW)

Model size (Rated kW)	Outdoor air temp. °C D.B.	Indoor air temp.													
		21.5°C D.B. 15°C W.B.		23°C D.B. 16°C W.B.		25°C D.B. 18°C W.B.		27°C D.B. 19°C W.B.		28°C D.B. 20°C W.B.		30°C D.B. 22°C W.B.		32°C D.B. 24°C W.B.	
		CA	SHC	CA	SHC	CA	SHC	CA	SHC	CA	SHC	CA	SHC	CA	SHC
20 (2.2)	20.0	2.1	1.8	2.2	1.9	2.4	1.9	2.4	2.0	2.5	2.0	2.7	2.0	2.9	1.9
	22.5	2.1	1.8	2.2	1.8	2.3	1.8	2.4	2.0	2.5	2.0	2.6	1.9	2.8	1.9
	25.0	2.1	1.8	2.1	1.8	2.3	1.8	2.4	2.0	2.4	1.9	2.6	1.9	2.8	1.9
	27.5	2.0	1.7	2.1	1.8	2.2	1.8	2.3	1.9	2.4	1.9	2.6	1.9	2.7	1.9
	30.0	2.0	1.7	2.0	1.8	2.2	1.8	2.3	1.9	2.4	1.9	2.5	1.9	2.7	1.9
	32.5	1.9	1.7	2.0	1.8	2.2	1.8	2.2	1.9	2.3	1.9	2.5	1.9	2.6	1.9
	35.0	1.9	1.7	2.0	1.8	2.1	1.8	2.2	1.9	2.3	1.9	2.4	1.9	2.6	1.8
	37.5	1.9	1.7	1.9	1.7	2.1	1.7	2.1	1.9	2.2	1.9	2.4	1.8	2.5	1.8
	40.0	1.8	1.7	1.9	1.7	2.0	1.7	2.1	1.9	2.2	1.8	2.3	1.8	2.5	1.8
43.0	1.8	1.6	1.8	1.7	2.0	1.7	2.1	1.8	2.1	1.8	2.3	1.8	2.4	1.8	
25 (2.8)	20.0	2.7	2.2	2.8	2.2	3.0	2.2	3.1	2.4	3.2	2.4	3.4	2.3	3.7	2.3
	22.5	2.7	2.1	2.8	2.2	3.0	2.2	3.1	2.4	3.2	2.3	3.4	2.3	3.6	2.3
	25.0	2.6	2.1	2.7	2.2	2.9	2.2	3.0	2.3	3.1	2.3	3.3	2.3	3.5	2.3
	27.5	2.6	2.1	2.7	2.2	2.9	2.2	3.0	2.3	3.1	2.3	3.3	2.3	3.5	2.3
	30.0	2.5	2.1	2.6	2.1	2.8	2.1	2.9	2.3	3.0	2.3	3.2	2.3	3.4	2.2
	32.5	2.5	2.1	2.6	2.1	2.7	2.1	2.8	2.3	2.9	2.3	3.1	2.2	3.3	2.2
	35.0	2.4	2.0	2.5	2.1	2.7	2.1	2.8	2.3	2.9	2.2	3.1	2.2	3.3	2.2
	37.5	2.4	2.0	2.5	2.1	2.6	2.1	2.7	2.2	2.8	2.2	3.0	2.2	3.2	2.2
	40.0	2.3	2.0	2.4	2.1	2.6	2.1	2.7	2.2	2.8	2.2	3.0	2.2	3.1	2.1
43.0	2.3	2.0	2.4	2.0	2.5	2.0	2.6	2.2	2.7	2.2	2.9	2.1	3.1	2.1	
32 (3.6)	20.0	3.5	2.6	3.6	2.7	3.9	2.7	4.0	2.9	4.1	2.9	4.4	2.8	4.7	2.8
	22.5	3.4	2.6	3.5	2.7	3.8	2.7	3.9	2.8	4.1	2.8	4.3	2.8	4.6	2.8
	25.0	3.4	2.6	3.5	2.7	3.7	2.7	3.9	2.8	4.0	2.8	4.3	2.8	4.5	2.7
	27.5	3.3	2.5	3.4	2.6	3.7	2.6	3.8	2.8	3.9	2.8	4.2	2.8	4.5	2.7
	30.0	3.2	2.5	3.4	2.6	3.6	2.6	3.7	2.8	3.9	2.7	4.1	2.7	4.4	2.7
	32.5	3.2	2.5	3.3	2.6	3.5	2.6	3.7	2.7	3.8	2.7	4.0	2.7	4.3	2.7
	35.0	3.1	2.5	3.2	2.5	3.5	2.5	3.6	2.7	3.7	2.7	4.0	2.7	4.2	2.6
	37.5	3.1	2.4	3.2	2.5	3.4	2.5	3.5	2.7	3.6	2.7	3.9	2.6	4.1	2.6
	40.0	3.0	2.4	3.1	2.5	3.3	2.5	3.4	2.6	3.6	2.6	3.8	2.6	4.0	2.6
43.0	2.9	2.4	3.0	2.4	3.2	2.4	3.4	2.6	3.5	2.6	3.7	2.6	3.9	2.5	
40 (4.5)	20.0	4.3	3.1	4.5	3.2	4.8	3.2	5.0	3.3	5.2	3.3	5.5	3.3	5.9	3.3
	22.5	4.3	3.0	4.4	3.1	4.7	3.1	4.9	3.3	5.1	3.3	5.4	3.3	5.8	3.2
	25.0	4.2	3.0	4.3	3.1	4.7	3.1	4.8	3.3	5.0	3.3	5.3	3.2	5.7	3.2
	27.5	4.1	3.0	4.3	3.1	4.6	3.0	4.7	3.2	4.9	3.2	5.2	3.2	5.6	3.1
	30.0	4.1	2.9	4.2	3.0	4.5	3.0	4.7	3.2	4.8	3.2	5.1	3.1	5.5	3.1
	32.5	4.0	2.9	4.1	3.0	4.4	3.0	4.6	3.1	4.7	3.1	5.0	3.1	5.4	3.1
	35.0	3.9	2.9	4.0	2.9	4.3	2.9	4.5	3.1	4.6	3.1	4.9	3.1	5.3	3.0
	37.5	3.8	2.8	4.0	2.9	4.2	2.9	4.4	3.1	4.5	3.1	4.8	3.0	5.2	3.0
	40.0	3.8	2.8	3.9	2.9	4.2	2.9	4.3	3.0	4.5	3.0	4.8	3.0	5.1	2.9
43.0	3.7	2.7	3.8	2.8	4.1	2.8	4.2	3.0	4.3	3.0	4.6	2.9	4.9	2.9	

kcal/h=kW x 860 , BTU/h = kW x 3,412

5. Cooling [Ceiling cassette (4-way flow type)]

PLFY-P-VBM-E

CA:Capacity(kW) , SHC:Sensible Heat Capacity(kW)

Model size (Rated kW)	Outdoor air temp.	Indoor air temp.													
		21.5°C D.B. 15°C W.B.		23°C D.B. 16°C W.B.		25°C D.B. 18°C W.B.		27°C D.B. 19°C W.B.		28°C D.B. 20°C W.B.		30°C D.B. 22°C W.B.		32°C D.B. 24°C W.B.	
		°C D.B.	CA	SHC	CA	SHC	CA	SHC	CA	SHC	CA	SHC	CA	SHC	CA
32 (3.6)	20.0	3.5	2.9	3.6	3.0	3.9	3.0	4.0	3.2	4.1	3.2	4.4	3.1	4.7	3.1
	22.5	3.4	2.8	3.5	2.9	3.8	2.9	3.9	3.1	4.1	3.1	4.3	3.1	4.6	3.1
	25.0	3.4	2.8	3.5	2.9	3.7	2.9	3.9	3.1	4.0	3.1	4.3	3.1	4.5	3.0
	27.5	3.3	2.8	3.4	2.9	3.7	2.9	3.8	3.1	3.9	3.1	4.2	3.0	4.5	3.0
	30.0	3.2	2.8	3.4	2.9	3.6	2.8	3.7	3.1	3.9	3.0	4.1	3.0	4.4	3.0
	32.5	3.2	2.7	3.3	2.8	3.5	2.8	3.7	3.0	3.8	3.0	4.0	3.0	4.3	2.9
	35.0	3.1	2.7	3.2	2.8	3.5	2.8	3.6	3.0	3.7	3.0	4.0	3.0	4.2	2.9
	37.5	3.1	2.7	3.2	2.8	3.4	2.8	3.5	3.0	3.6	3.0	3.9	2.9	4.1	2.9
	40.0	3.0	2.6	3.1	2.7	3.3	2.7	3.4	2.9	3.6	2.9	3.8	2.9	4.0	2.9
43.0	2.9	2.6	3.0	2.7	3.2	2.7	3.4	2.9	3.5	2.9	3.7	2.9	3.9	2.8	
40 (4.5)	20.0	4.3	3.5	4.5	3.6	4.8	3.6	5.0	3.8	5.2	3.8	5.5	3.8	5.9	3.7
	22.5	4.3	3.5	4.4	3.6	4.7	3.6	4.9	3.8	5.1	3.8	5.4	3.8	5.8	3.7
	25.0	4.2	3.4	4.3	3.5	4.7	3.5	4.8	3.8	5.0	3.8	5.3	3.7	5.7	3.7
	27.5	4.1	3.4	4.3	3.5	4.6	3.5	4.7	3.7	4.9	3.7	5.2	3.7	5.6	3.6
	30.0	4.1	3.3	4.2	3.5	4.5	3.5	4.7	3.7	4.8	3.7	5.1	3.6	5.5	3.6
	32.5	4.0	3.3	4.1	3.4	4.4	3.4	4.6	3.7	4.7	3.6	5.0	3.6	5.4	3.6
	35.0	3.9	3.3	4.0	3.4	4.3	3.4	4.5	3.6	4.6	3.6	4.9	3.6	5.3	3.5
	37.5	3.8	3.2	4.0	3.4	4.2	3.3	4.4	3.6	4.5	3.6	4.8	3.5	5.2	3.5
	40.0	3.8	3.2	3.9	3.3	4.2	3.3	4.3	3.6	4.5	3.5	4.8	3.5	5.1	3.5
43.0	3.7	3.2	3.8	3.3	4.1	3.3	4.2	3.5	4.3	3.5	4.6	3.5	4.9	3.4	
50 (5.6)	20.0	5.4	4.0	5.6	4.2	6.0	4.2	6.2	4.4	6.4	4.4	6.9	4.3	7.3	4.3
	22.5	5.3	4.0	5.5	4.1	5.9	4.1	6.1	4.4	6.3	4.3	6.7	4.3	7.2	4.2
	25.0	5.2	3.9	5.4	4.1	5.8	4.1	6.0	4.3	6.2	4.3	6.6	4.3	7.0	4.2
	27.5	5.1	3.9	5.3	4.0	5.7	4.0	5.9	4.3	6.1	4.3	6.5	4.2	6.9	4.2
	30.0	5.0	3.9	5.2	4.0	5.6	4.0	5.8	4.2	6.0	4.2	6.4	4.2	6.8	4.1
	32.5	5.0	3.8	5.1	3.9	5.5	3.9	5.7	4.2	5.9	4.2	6.3	4.1	6.7	4.1
	35.0	4.9	3.8	5.0	3.9	5.4	3.9	5.6	4.1	5.8	4.1	6.2	4.1	6.5	4.0
	37.5	4.8	3.7	4.9	3.8	5.3	3.8	5.5	4.1	5.7	4.1	6.0	4.0	6.4	4.0
	40.0	4.7	3.7	4.8	3.8	5.2	3.8	5.4	4.0	5.5	4.0	5.9	4.0	6.3	3.9
43.0	4.6	3.6	4.7	3.7	5.1	3.7	5.2	4.0	5.4	4.0	5.8	3.9	6.1	3.9	
63 (7.1)	20.0	6.9	5.0	7.1	5.1	7.6	5.1	7.9	5.4	8.2	5.4	8.7	5.3	9.3	5.3
	22.5	6.7	4.9	7.0	5.1	7.5	5.0	7.8	5.3	8.0	5.3	8.6	5.3	9.1	5.2
	25.0	6.6	4.9	6.9	5.0	7.4	5.0	7.6	5.3	7.9	5.3	8.4	5.2	8.9	5.1
	27.5	6.5	4.8	6.7	4.9	7.2	4.9	7.5	5.2	7.7	5.2	8.3	5.1	8.8	5.1
	30.0	6.4	4.7	6.6	4.9	7.1	4.9	7.3	5.2	7.6	5.1	8.1	5.1	8.6	5.0
	32.5	6.3	4.7	6.5	4.8	7.0	4.8	7.2	5.1	7.5	5.1	7.9	5.0	8.5	5.0
	35.0	6.2	4.6	6.4	4.8	6.8	4.7	7.1	5.0	7.3	5.0	7.8	5.0	8.3	4.9
	37.5	6.1	4.6	6.2	4.7	6.7	4.7	6.9	5.0	7.2	5.0	7.6	4.9	8.1	4.8
	40.0	5.9	4.5	6.1	4.6	6.6	4.6	6.8	4.9	7.0	4.9	7.5	4.9	8.0	4.8
43.0	5.8	4.4	6.0	4.6	6.4	4.6	6.6	4.8	6.9	4.8	7.3	4.8	7.8	4.7	
80 (9.0)	20.0	8.7	6.2	9.0	6.4	9.7	6.4	10.0	6.7	10.3	6.7	11.0	6.6	11.7	6.5
	22.5	8.5	6.1	8.9	6.3	9.5	6.3	9.8	6.6	10.2	6.6	10.8	6.5	11.5	6.5
	25.0	8.4	6.0	8.7	6.2	9.3	6.2	9.7	6.6	10.0	6.5	10.6	6.5	11.3	6.4
	27.5	8.3	6.0	8.5	6.1	9.2	6.1	9.5	6.5	9.8	6.5	10.5	6.4	11.1	6.3
	30.0	8.1	5.9	8.4	6.1	9.0	6.0	9.3	6.4	9.6	6.4	10.3	6.3	10.9	6.2
	32.5	8.0	5.8	8.2	6.0	8.8	6.0	9.1	6.3	9.4	6.3	10.1	6.2	10.7	6.2
	35.0	7.8	5.7	8.1	5.9	8.7	5.9	9.0	6.3	9.3	6.2	9.9	6.2	10.5	6.1
	37.5	7.7	5.7	7.9	5.8	8.5	5.8	8.8	6.2	9.1	6.1	9.7	6.1	10.3	6.0
	40.0	7.5	5.6	7.7	5.7	8.3	5.7	8.6	6.1	8.9	6.1	9.5	6.0	10.1	5.9
43.0	7.4	5.5	7.6	5.7	8.1	5.6	8.4	6.0	8.7	6.0	9.3	5.9	9.9	5.8	
100 (11.2)	20.0	10.8	7.7	11.2	8.0	12.0	8.0	12.5	8.4	12.9	8.4	13.7	8.3	14.6	8.2
	22.5	10.6	7.6	11.0	7.9	11.8	7.9	12.2	8.3	12.6	8.3	13.5	8.2	14.4	8.1
	25.0	10.5	7.6	10.8	7.8	11.6	7.8	12.0	8.2	12.4	8.2	13.3	8.1	14.1	8.0
	27.5	10.3	7.5	10.6	7.7	11.4	7.7	11.8	8.1	12.2	8.1	13.0	8.0	13.8	7.9
	30.0	10.1	7.4	10.4	7.6	11.2	7.6	11.6	8.0	12.0	8.0	12.8	7.9	13.6	7.8
	32.5	9.9	7.3	10.2	7.5	11.0	7.5	11.4	7.9	11.8	7.9	12.5	7.8	13.3	7.7
	35.0	9.7	7.2	10.0	7.4	10.8	7.4	11.2	7.8	11.5	7.8	12.3	7.7	13.1	7.6
	37.5	9.5	7.1	9.8	7.3	10.6	7.3	10.9	7.7	11.3	7.7	12.1	7.6	12.8	7.5
	40.0	9.4	7.0	9.6	7.2	10.4	7.2	10.7	7.6	11.1	7.6	11.8	7.5	12.6	7.4
43.0	9.2	6.9	9.4	7.1	10.1	7.1	10.5	7.5	10.8	7.5	11.5	7.4	12.3	7.3	
125 (14.0)	20.0	13.5	9.4	14.0	9.7	15.0	9.7	15.6	10.2	16.1	10.2	17.2	10.1	18.3	9.9
	22.5	13.3	9.3	13.8	9.6	14.8	9.6	15.3	10.1	15.8	10.0	16.9	9.9	17.9	9.8
	25.0	13.1	9.2	13.5	9.5	14.5	9.4	15.0	9.9	15.5	9.9	16.6	9.8	17.6	9.7
	27.5	12.8	9.1	13.3	9.3	14.3	9.3	14.8	9.8	15.3	9.8	16.3	9.7	17.3	9.6
	30.0	12.6	9.0	13.0	9.2	14.0	9.2	14.5	9.7	15.0	9.7	16.0	9.6	17.0	9.4
	32.5	12.4	8.8	12.8	9.1	13.7	9.1	14.2	9.6	14.7	9.5	15.7	9.4	16.7	9.3
	35.0	12.2	8.7	12.5	8.9	13.5	8.9	14.0	9.5	14.4	9.4	15.4	9.3	16.4	9.2
	37.5	11.9	8.6	12.3	8.8	13.2	8.8	13.7	9.3	14.1	9.3	15.1	9.2	16.0	9.1
	40.0	11.7	8.5	12.1	8.7	12.9	8.7	13.4	9.2	13.9	9.2	14.8	9.1	15.7	9.0
43.0	11.4	8.3	11.8	8.6	12.6	8.5	13.1	9.0	13.5	9.0	14.4	8.9	15.4	8.8	

kcal/h=kW x 860 , BTU/h = kW x 3,412

5. Cooling [Ceiling cassette (4-way flow type)]

5-5. Cooling capacity with PUHY-RP850-900YSJM

PLFY-P-VCM-E

CA:Capacity(kW) , SHC:Sensible Heat Capacity(kW)

Model size (Rated kW)	Outdoor air temp. °C D.B.	Indoor air temp.													
		21.5°C D.B. 15°C W.B.		23°C D.B. 16°C W.B.		25°C D.B. 18°C W.B.		27°C D.B. 19°C W.B.		28°C D.B. 20°C W.B.		30°C D.B. 22°C W.B.		32°C D.B. 24°C W.B.	
		CA	SHC	CA	SHC	CA	SHC	CA	SHC	CA	SHC	CA	SHC	CA	SHC
20 (2.2)	20.0	2.1	1.8	2.1	1.8	2.3	1.8	2.4	2.0	2.4	1.9	2.6	1.9	2.8	1.9
	22.5	2.1	1.8	2.1	1.8	2.3	1.8	2.3	1.9	2.4	1.9	2.6	1.9	2.7	1.9
	25.0	2.0	1.8	2.1	1.8	2.2	1.8	2.3	1.9	2.4	1.9	2.5	1.9	2.7	1.9
	27.5	2.0	1.7	2.1	1.8	2.2	1.8	2.3	1.9	2.4	1.9	2.5	1.9	2.7	1.9
	30.0	2.0	1.7	2.0	1.8	2.2	1.8	2.3	1.9	2.3	1.9	2.5	1.9	2.7	1.9
	32.5	2.0	1.7	2.0	1.8	2.2	1.8	2.2	1.9	2.3	1.9	2.5	1.9	2.6	1.9
	35.0	2.0	1.7	2.0	1.8	2.1	1.8	2.2	1.9	2.3	1.9	2.5	1.9	2.6	1.9
	37.5	1.9	1.7	2.0	1.8	2.1	1.8	2.2	1.9	2.3	1.9	2.4	1.9	2.6	1.8
	40.0	1.9	1.7	1.9	1.7	2.1	1.7	2.2	1.9	2.2	1.9	2.4	1.9	2.6	1.8
43.0	1.9	1.7	1.9	1.7	2.1	1.7	2.1	1.9	2.2	1.9	2.4	1.8	2.5	1.8	
25 (2.8)	20.0	2.6	2.1	2.7	2.2	2.9	2.2	3.0	2.3	3.1	2.3	3.3	2.3	3.5	2.3
	22.5	2.6	2.1	2.7	2.2	2.9	2.2	3.0	2.3	3.1	2.3	3.3	2.3	3.5	2.3
	25.0	2.6	2.1	2.7	2.2	2.9	2.2	2.9	2.3	3.0	2.3	3.2	2.3	3.5	2.3
	27.5	2.6	2.1	2.6	2.2	2.8	2.1	2.9	2.3	3.0	2.3	3.2	2.3	3.4	2.2
	30.0	2.5	2.1	2.6	2.1	2.8	2.1	2.9	2.3	3.0	2.3	3.2	2.3	3.4	2.2
	32.5	2.5	2.1	2.6	2.1	2.8	2.1	2.9	2.3	3.0	2.3	3.2	2.2	3.4	2.2
	35.0	2.5	2.1	2.5	2.1	2.7	2.1	2.8	2.3	2.9	2.3	3.1	2.2	3.3	2.2
	37.5	2.5	2.0	2.5	2.1	2.7	2.1	2.8	2.2	2.9	2.2	3.1	2.2	3.3	2.2
	40.0	2.4	2.0	2.5	2.1	2.7	2.1	2.8	2.2	2.9	2.2	3.1	2.2	3.3	2.2
43.0	2.4	2.0	2.4	2.1	2.6	2.1	2.7	2.2	2.8	2.2	3.0	2.2	3.2	2.2	
32 (3.6)	20.0	3.4	2.6	3.5	2.7	3.7	2.7	3.9	2.8	4.0	2.8	4.3	2.8	4.5	2.7
	22.5	3.4	2.6	3.5	2.7	3.7	2.6	3.8	2.8	4.0	2.8	4.2	2.8	4.5	2.7
	25.0	3.3	2.6	3.4	2.6	3.7	2.6	3.8	2.8	3.9	2.8	4.2	2.7	4.4	2.7
	27.5	3.3	2.5	3.4	2.6	3.6	2.6	3.8	2.8	3.9	2.8	4.1	2.7	4.4	2.7
	30.0	3.3	2.5	3.3	2.6	3.6	2.6	3.7	2.8	3.8	2.7	4.1	2.7	4.4	2.7
	32.5	3.2	2.5	3.3	2.6	3.5	2.6	3.7	2.7	3.8	2.7	4.1	2.7	4.3	2.7
	35.0	3.2	2.5	3.3	2.6	3.5	2.6	3.6	2.7	3.8	2.7	4.0	2.7	4.3	2.7
	37.5	3.2	2.5	3.2	2.5	3.5	2.5	3.6	2.7	3.7	2.7	4.0	2.7	4.2	2.6
	40.0	3.1	2.5	3.2	2.5	3.4	2.5	3.5	2.7	3.7	2.7	3.9	2.7	4.2	2.6
43.0	3.1	2.4	3.1	2.5	3.4	2.5	3.5	2.7	3.6	2.7	3.9	2.6	4.2	2.6	
40 (4.5)	20.0	4.3	3.0	4.4	3.1	4.7	3.1	4.8	3.3	5.0	3.3	5.3	3.2	5.7	3.2
	22.5	4.2	3.0	4.3	3.1	4.6	3.1	4.8	3.2	4.9	3.2	5.3	3.2	5.6	3.2
	25.0	4.2	3.0	4.3	3.1	4.6	3.1	4.7	3.2	4.9	3.2	5.2	3.2	5.6	3.1
	27.5	4.1	3.0	4.2	3.0	4.5	3.0	4.7	3.2	4.8	3.2	5.2	3.2	5.5	3.1
	30.0	4.1	2.9	4.2	3.0	4.5	3.0	4.6	3.2	4.8	3.2	5.1	3.1	5.5	3.1
	32.5	4.0	2.9	4.1	3.0	4.4	3.0	4.6	3.2	4.7	3.1	5.1	3.1	5.4	3.1
	35.0	4.0	2.9	4.1	3.0	4.4	3.0	4.5	3.1	4.7	3.1	5.0	3.1	5.4	3.1
	37.5	4.0	2.9	4.0	2.9	4.3	2.9	4.5	3.1	4.6	3.1	5.0	3.1	5.3	3.0
	40.0	3.9	2.9	4.0	2.9	4.3	2.9	4.4	3.1	4.6	3.1	4.9	3.1	5.3	3.0
43.0	3.9	2.8	3.9	2.9	4.2	2.9	4.4	3.1	4.5	3.0	4.9	3.0	5.2	3.0	

kcal/h=kW x 860 , BTU/h = kW x 3,412

5. Cooling [Ceiling cassette (4-way flow type)]

PLFY-P-VBM-E

CA:Capacity(kW) , SHC:Sensible Heat Capacity(kW)

Model size (Rated kW)	Outdoor air temp.	Indoor air temp.													
		21.5°C D.B. 15°C W.B.		23°C D.B. 16°C W.B.		25°C D.B. 18°C W.B.		27°C D.B. 19°C W.B.		28°C D.B. 20°C W.B.		30°C D.B. 22°C W.B.		32°C D.B. 24°C W.B.	
		°C D.B.	CA	SHC	CA	SHC	CA	SHC	CA	SHC	CA	SHC	CA	SHC	CA
32 (3.6)	20.0	3.4	2.8	3.5	2.9	3.7	2.9	3.9	3.1	4.0	3.1	4.3	3.1	4.5	3.0
	22.5	3.4	2.8	3.5	2.9	3.7	2.9	3.8	3.1	4.0	3.1	4.2	3.0	4.5	3.0
	25.0	3.3	2.8	3.4	2.9	3.7	2.9	3.8	3.1	3.9	3.1	4.2	3.0	4.4	3.0
	27.5	3.3	2.8	3.4	2.9	3.6	2.9	3.8	3.1	3.9	3.1	4.1	3.0	4.4	3.0
	30.0	3.3	2.8	3.3	2.9	3.6	2.8	3.7	3.0	3.8	3.0	4.1	3.0	4.4	3.0
	32.5	3.2	2.7	3.3	2.8	3.5	2.8	3.7	3.0	3.8	3.0	4.1	3.0	4.3	3.0
	35.0	3.2	2.7	3.3	2.8	3.5	2.8	3.6	3.0	3.8	3.0	4.0	3.0	4.3	2.9
	37.5	3.2	2.7	3.2	2.8	3.5	2.8	3.6	3.0	3.7	3.0	4.0	3.0	4.2	2.9
	40.0	3.1	2.7	3.2	2.8	3.4	2.8	3.5	3.0	3.7	3.0	3.9	3.0	4.2	2.9
43.0	3.1	2.7	3.1	2.8	3.4	2.8	3.5	3.0	3.6	3.0	3.9	2.9	4.2	2.9	
40 (4.5)	20.0	4.3	3.4	4.4	3.6	4.7	3.5	4.8	3.8	5.0	3.8	5.3	3.7	5.7	3.7
	22.5	4.2	3.4	4.3	3.5	4.6	3.5	4.8	3.8	4.9	3.7	5.3	3.7	5.6	3.6
	25.0	4.2	3.4	4.3	3.5	4.6	3.5	4.7	3.7	4.9	3.7	5.2	3.7	5.6	3.6
	27.5	4.1	3.4	4.2	3.5	4.5	3.5	4.7	3.7	4.8	3.7	5.2	3.7	5.5	3.6
	30.0	4.1	3.4	4.2	3.5	4.5	3.4	4.6	3.7	4.8	3.7	5.1	3.6	5.5	3.6
	32.5	4.0	3.3	4.1	3.4	4.4	3.4	4.6	3.7	4.7	3.7	5.1	3.6	5.4	3.6
	35.0	4.0	3.3	4.1	3.4	4.4	3.4	4.5	3.6	4.7	3.6	5.0	3.6	5.4	3.6
	37.5	4.0	3.3	4.0	3.4	4.3	3.4	4.5	3.6	4.6	3.6	5.0	3.6	5.3	3.6
	40.0	3.9	3.3	4.0	3.4	4.3	3.4	4.4	3.6	4.6	3.6	4.9	3.6	5.3	3.5
43.0	3.9	3.3	3.9	3.3	4.2	3.3	4.4	3.6	4.5	3.6	4.9	3.5	5.2	3.5	
50 (5.6)	20.0	5.3	4.0	5.5	4.1	5.8	4.1	6.0	4.3	6.2	4.3	6.6	4.3	7.0	4.2
	22.5	5.2	4.0	5.4	4.1	5.8	4.0	6.0	4.3	6.2	4.3	6.6	4.2	7.0	4.2
	25.0	5.2	3.9	5.3	4.0	5.7	4.0	5.9	4.3	6.1	4.2	6.5	4.2	6.9	4.2
	27.5	5.1	3.9	5.3	4.0	5.6	4.0	5.8	4.2	6.0	4.2	6.4	4.2	6.9	4.1
	30.0	5.1	3.9	5.2	4.0	5.6	4.0	5.8	4.2	6.0	4.2	6.4	4.2	6.8	4.1
	32.5	5.0	3.8	5.1	3.9	5.5	3.9	5.7	4.2	5.9	4.2	6.3	4.1	6.7	4.1
	35.0	5.0	3.8	5.1	3.9	5.4	3.9	5.6	4.1	5.8	4.1	6.2	4.1	6.7	4.1
	37.5	4.9	3.8	5.0	3.9	5.4	3.9	5.6	4.1	5.8	4.1	6.2	4.1	6.6	4.0
	40.0	4.9	3.8	4.9	3.9	5.3	3.8	5.5	4.1	5.7	4.1	6.1	4.1	6.5	4.0
43.0	4.8	3.7	4.9	3.8	5.2	3.8	5.4	4.1	5.6	4.1	6.0	4.0	6.5	4.0	
63 (7.1)	20.0	6.7	4.9	6.9	5.0	7.4	5.0	7.6	5.3	7.9	5.3	8.4	5.2	8.9	5.1
	22.5	6.6	4.9	6.8	5.0	7.3	5.0	7.6	5.3	7.8	5.2	8.3	5.2	8.8	5.1
	25.0	6.6	4.8	6.8	4.9	7.2	4.9	7.5	5.2	7.7	5.2	8.2	5.1	8.8	5.1
	27.5	6.5	4.8	6.7	4.9	7.2	4.9	7.4	5.2	7.6	5.2	8.2	5.1	8.7	5.0
	30.0	6.4	4.8	6.6	4.9	7.1	4.9	7.3	5.1	7.6	5.1	8.1	5.1	8.6	5.0
	32.5	6.4	4.7	6.5	4.8	7.0	4.8	7.2	5.1	7.5	5.1	8.0	5.0	8.5	5.0
	35.0	6.3	4.7	6.4	4.8	6.9	4.8	7.1	5.0	7.4	5.1	7.9	5.0	8.5	5.0
	37.5	6.2	4.7	6.3	4.8	6.8	4.7	7.1	5.0	7.3	5.0	7.8	5.0	8.4	4.9
	40.0	6.2	4.6	6.3	4.7	6.7	4.7	7.0	5.0	7.2	5.0	7.8	5.0	8.3	4.9
43.0	6.1	4.6	6.2	4.7	6.7	4.7	6.9	5.0	7.1	5.0	7.7	4.9	8.2	4.9	
80 (9.0)	20.0	8.5	6.1	8.8	6.2	9.4	6.2	9.7	6.6	10.0	6.5	10.6	6.5	11.3	6.4
	22.5	8.4	6.0	8.7	6.2	9.3	6.2	9.6	6.5	9.9	6.5	10.5	6.4	11.2	6.3
	25.0	8.3	6.0	8.6	6.1	9.2	6.1	9.5	6.5	9.8	6.4	10.4	6.4	11.1	6.3
	27.5	8.3	6.0	8.5	6.1	9.1	6.1	9.4	6.4	9.7	6.4	10.3	6.3	11.0	6.3
	30.0	8.2	5.9	8.4	6.0	9.0	6.0	9.3	6.4	9.6	6.4	10.2	6.3	10.9	6.2
	32.5	8.1	5.9	8.3	6.0	8.9	6.0	9.2	6.3	9.5	6.3	10.1	6.3	10.8	6.2
	35.0	8.0	5.8	8.1	5.9	8.8	5.9	9.0	6.3	9.4	6.3	10.0	6.2	10.7	6.2
	37.5	7.9	5.8	8.0	5.9	8.7	5.9	9.0	6.2	9.3	6.2	9.9	6.2	10.6	6.1
	40.0	7.8	5.7	7.9	5.8	8.6	5.8	8.9	6.2	9.2	6.2	9.8	6.1	10.5	6.1
43.0	7.7	5.7	7.8	5.8	8.4	5.8	8.7	6.1	9.1	6.1	9.7	6.1	10.4	6.0	
100 (11.2)	20.0	10.6	7.6	10.9	7.8	11.7	7.8	12.0	8.2	12.4	8.2	13.2	8.1	14.1	8.0
	22.5	10.5	7.6	10.8	7.8	11.5	7.7	11.9	8.2	12.3	8.1	13.1	8.0	13.9	7.9
	25.0	10.4	7.5	10.6	7.7	11.4	7.7	11.8	8.1	12.2	8.1	13.0	8.0	13.8	7.9
	27.5	10.3	7.5	10.5	7.6	11.3	7.6	11.7	8.0	12.1	8.0	12.9	7.9	13.7	7.8
	30.0	10.2	7.4	10.4	7.6	11.2	7.5	11.5	8.0	11.9	8.0	12.7	7.9	13.6	7.8
	32.5	10.1	7.3	10.3	7.5	11.0	7.5	11.4	7.9	11.8	7.9	12.6	7.8	13.5	7.7
	35.0	9.9	7.3	10.1	7.4	10.9	7.4	11.2	7.8	11.7	7.8	12.5	7.8	13.3	7.7
	37.5	9.8	7.2	10.0	7.4	10.8	7.4	11.2	7.8	11.6	7.8	12.4	7.7	13.2	7.7
	40.0	9.7	7.2	9.9	7.3	10.6	7.3	11.0	7.8	11.4	7.7	12.2	7.7	13.1	7.6
43.0	9.6	7.1	9.7	7.2	10.5	7.2	10.9	7.7	11.3	7.7	12.1	7.6	12.9	7.6	
125 (14.0)	20.0	13.2	9.3	13.6	9.5	14.6	9.5	15.1	10.0	15.5	9.9	16.5	9.8	17.6	9.7
	22.5	13.1	9.2	13.5	9.4	14.4	9.4	14.9	9.9	15.4	9.8	16.4	9.7	17.4	9.6
	25.0	13.0	9.1	13.3	9.3	14.3	9.3	14.7	9.8	15.2	9.8	16.2	9.7	17.3	9.5
	27.5	12.8	9.1	13.2	9.3	14.1	9.2	14.6	9.7	15.1	9.7	16.1	9.6	17.1	9.5
	30.0	12.7	9.0	13.0	9.2	13.9	9.2	14.4	9.7	14.9	9.6	15.9	9.5	17.0	9.4
	32.5	12.6	8.9	12.8	9.1	13.8	9.1	14.3	9.6	14.8	9.6	15.8	9.5	16.8	9.4
	35.0	12.4	8.9	12.7	9.0	13.6	9.0	14.0	9.5	14.6	9.5	15.6	9.4	16.7	9.3
	37.5	12.3	8.8	12.5	8.9	13.5	8.9	14.0	9.4	14.4	9.4	15.5	9.3	16.5	9.3
	40.0	12.2	8.7	12.4	8.9	13.3	8.9	13.8	9.4	14.3	9.3	15.3	9.3	16.4	9.2
43.0	12.0	8.6	12.2	8.8	13.1	8.8	13.6	9.3	14.1	9.3	15.1	9.2	16.2	9.1	

kcal/h=KW x 860 , BTU/h = KW x 3,412

6. Cooling [Ceiling suspended]

6-1. Cooling capacity with PUHY,PURY-RP200-250YJM

PCFY-P-VKM-E

CA:Capacity(kW) , SHC:Sensible Heat Capacity(kW)

Model size (Rated kW)	Outdoor air temp. °C D.B.	Indoor air temp.													
		21.5°C D.B. 15°C W.B.		23°C D.B. 16°C W.B.		25°C D.B. 18°C W.B.		27°C D.B. 19°C W.B.		28°C D.B. 20°C W.B.		30°C D.B. 22°C W.B.		32°C D.B. 24°C W.B.	
		CA	SHC	CA	SHC	CA	SHC	CA	SHC	CA	SHC	CA	SHC	CA	SHC
40 (4.5)	20.0	4.3	3.1	4.4	3.2	4.7	3.2	4.9	3.3	5.0	3.3	5.3	3.3	5.7	3.2
	22.5	4.3	3.1	4.4	3.2	4.7	3.2	4.9	3.3	5.0	3.3	5.3	3.3	5.7	3.2
	25.0	4.3	3.1	4.4	3.2	4.7	3.2	4.9	3.3	5.0	3.3	5.3	3.2	5.6	3.2
	27.5	4.3	3.1	4.4	3.1	4.6	3.1	4.8	3.3	4.9	3.2	5.2	3.2	5.5	3.1
	30.0	4.2	3.0	4.3	3.1	4.6	3.1	4.7	3.2	4.8	3.2	5.1	3.2	5.4	3.1
	32.5	4.1	3.0	4.2	3.1	4.5	3.0	4.6	3.2	4.7	3.2	5.0	3.1	5.3	3.1
	35.0	4.0	3.0	4.1	3.0	4.4	3.0	4.5	3.2	4.6	3.1	4.9	3.1	5.2	3.0
	37.5	4.0	2.9	4.1	3.0	4.3	3.0	4.4	3.1	4.5	3.1	4.8	3.0	5.0	3.0
	40.0	3.9	2.9	4.0	3.0	4.2	2.9	4.3	3.1	4.4	3.1	4.7	3.0	4.9	2.9
43.0	3.8	2.8	3.9	2.9	4.1	2.9	4.2	3.0	4.3	3.0	4.5	2.9	4.8	2.9	
63 (7.1)	20.0	6.7	4.8	7.0	4.9	7.5	4.9	7.7	5.2	7.9	5.1	8.4	5.1	9.0	5.0
	22.5	6.7	4.8	7.0	4.9	7.5	4.9	7.7	5.2	7.9	5.1	8.4	5.1	9.0	5.0
	25.0	6.7	4.8	7.0	4.9	7.5	4.9	7.7	5.1	7.9	5.1	8.3	5.0	8.8	5.0
	27.5	6.7	4.8	6.9	4.9	7.3	4.8	7.5	5.1	7.7	5.0	8.1	5.0	8.7	4.9
	30.0	6.6	4.7	6.8	4.8	7.2	4.8	7.4	5.0	7.6	5.0	8.0	4.9	8.5	4.8
	32.5	6.5	4.7	6.7	4.8	7.1	4.7	7.2	5.0	7.4	4.9	7.8	4.8	8.3	4.8
	35.0	6.4	4.6	6.5	4.7	6.9	4.7	7.1	4.9	7.3	4.9	7.7	4.8	8.1	4.7
	37.5	6.2	4.5	6.4	4.6	6.8	4.6	7.0	4.8	7.2	4.8	7.5	4.7	8.0	4.6
	40.0	6.1	4.5	6.3	4.6	6.7	4.5	6.8	4.8	7.0	4.7	7.4	4.6	7.8	4.6
43.0	6.0	4.4	6.1	4.5	6.5	4.5	6.7	4.7	6.9	4.7	7.2	4.6	7.6	4.5	
100 (11.2)	20.0	10.6	7.4	11.0	7.6	11.8	7.6	12.1	8.0	12.5	7.9	13.2	7.8	14.2	7.8
	22.5	10.6	7.4	11.0	7.6	11.8	7.6	12.1	8.0	12.5	7.9	13.2	7.8	14.2	7.8
	25.0	10.6	7.4	11.0	7.6	11.8	7.6	12.1	8.0	12.4	7.9	13.1	7.8	13.9	7.7
	27.5	10.6	7.4	10.9	7.6	11.6	7.5	11.9	7.9	12.2	7.8	12.9	7.7	13.7	7.6
	30.0	10.4	7.3	10.7	7.5	11.3	7.4	11.6	7.8	12.0	7.7	12.6	7.6	13.4	7.4
	32.5	10.2	7.2	10.5	7.4	11.1	7.3	11.4	7.7	11.7	7.6	12.4	7.5	13.1	7.3
	35.0	10.0	7.1	10.3	7.3	10.9	7.2	11.2	7.5	11.5	7.5	12.1	7.3	12.8	7.2
	37.5	9.8	7.0	10.1	7.2	10.7	7.1	11.0	7.5	11.3	7.4	11.9	7.2	12.6	7.1
	40.0	9.6	6.9	9.9	7.1	10.5	7.0	10.8	7.4	11.1	7.3	11.6	7.1	12.3	7.0
43.0	9.4	6.8	9.7	7.0	10.2	6.9	10.5	7.2	10.8	7.2	11.3	7.0	12.0	6.9	
125 (14.0)	20.0	13.3	9.2	13.8	9.5	14.7	9.5	15.2	9.9	15.6	9.9	16.6	9.7	17.7	9.6
	22.5	13.3	9.2	13.8	9.5	14.7	9.5	15.2	9.9	15.6	9.9	16.6	9.7	17.7	9.6
	25.0	13.3	9.2	13.8	9.5	14.7	9.5	15.1	9.9	15.5	9.8	16.4	9.7	17.4	9.5
	27.5	13.3	9.2	13.6	9.4	14.4	9.3	14.8	9.8	15.2	9.7	16.1	9.5	17.1	9.4
	30.0	13.0	9.1	13.4	9.3	14.2	9.2	14.6	9.6	14.9	9.6	15.8	9.4	16.7	9.3
	32.5	12.8	9.0	13.2	9.2	13.9	9.1	14.3	9.5	14.7	9.4	15.4	9.3	16.4	9.1
	35.0	12.5	8.8	12.9	9.1	13.7	8.9	14.0	9.4	14.4	9.3	15.1	9.1	16.0	9.0
	37.5	12.3	8.7	12.7	8.9	13.4	8.8	13.8	9.3	14.1	9.2	14.8	9.0	15.7	8.9
	40.0	12.1	8.6	12.4	8.8	13.1	8.7	13.5	9.1	13.8	9.1	14.5	8.9	15.4	8.7
43.0	11.8	8.4	12.1	8.7	12.8	8.5	13.2	9.0	13.5	8.9	14.1	8.7	15.0	8.6	

kcal/h=kW x 860 , BTU/h = kW x 3,412

6. Cooling [Ceiling suspended]

6-2. Cooling capacity with PUHY-RP300-400Y(S)JM,PURY-RP300YJM

PCFY-P-VKM-E

CA:Capacity(kW) , SHC:Sensible Heat Capacity(kW)

Model size (Rated kW)	Outdoor air temp. °C D.B.	Indoor air temp.													
		21.5°C D.B. 15°C W.B.		23°C D.B. 16°C W.B.		25°C D.B. 18°C W.B.		27°C D.B. 19°C W.B.		28°C D.B. 20°C W.B.		30°C D.B. 22°C W.B.		32°C D.B. 24°C W.B.	
		CA	SHC	CA	SHC	CA	SHC	CA	SHC	CA	SHC	CA	SHC	CA	SHC
40 (4.5)	20.0	4.4	3.1	4.5	3.2	4.9	3.2	5.0	3.4	5.2	3.4	5.5	3.3	5.8	3.3
	22.5	4.4	3.1	4.5	3.2	4.8	3.2	4.9	3.4	5.1	3.3	5.4	3.3	5.7	3.2
	25.0	4.3	3.1	4.4	3.2	4.7	3.1	4.9	3.3	5.0	3.3	5.3	3.3	5.6	3.2
	27.5	4.2	3.0	4.3	3.1	4.6	3.1	4.8	3.3	4.9	3.3	5.2	3.2	5.5	3.2
	30.0	4.1	3.0	4.2	3.1	4.5	3.1	4.7	3.2	4.8	3.2	5.1	3.2	5.4	3.1
	32.5	4.1	3.0	4.2	3.0	4.4	3.0	4.6	3.2	4.7	3.2	5.0	3.1	5.3	3.1
	35.0	4.0	2.9	4.1	3.0	4.3	3.0	4.5	3.2	4.6	3.1	4.9	3.1	5.2	3.0
	37.5	3.9	2.9	4.0	3.0	4.2	2.9	4.4	3.1	4.5	3.1	4.8	3.0	5.1	3.0
	40.0	3.9	2.9	3.9	2.9	4.2	2.9	4.3	3.1	4.4	3.0	4.7	3.0	5.0	3.0
43.0	3.8	2.8	3.8	2.9	4.0	2.8	4.2	3.0	4.3	3.0	4.6	3.0	4.8	2.9	
63 (7.1)	20.0	6.9	4.9	7.1	5.0	7.7	5.0	7.9	5.3	8.2	5.3	8.7	5.2	9.2	5.1
	22.5	6.9	4.9	7.1	5.0	7.6	5.0	7.8	5.2	8.0	5.2	8.5	5.1	9.1	5.0
	25.0	6.8	4.8	7.0	4.9	7.4	4.9	7.7	5.1	7.9	5.1	8.4	5.1	8.9	5.0
	27.5	6.7	4.7	6.8	4.8	7.3	4.8	7.5	5.1	7.7	5.0	8.2	5.0	8.7	4.9
	30.0	6.5	4.7	6.7	4.8	7.1	4.7	7.4	5.0	7.6	5.0	8.1	4.9	8.5	4.8
	32.5	6.4	4.6	6.6	4.7	7.0	4.7	7.2	4.9	7.4	4.9	7.9	4.9	8.4	4.8
	35.0	6.3	4.6	6.4	4.6	6.8	4.6	7.1	4.9	7.3	4.8	7.7	4.8	8.2	4.7
	37.5	6.2	4.5	6.3	4.6	6.7	4.5	6.9	4.8	7.1	4.8	7.6	4.7	8.0	4.6
	40.0	6.1	4.5	6.2	4.5	6.6	4.5	6.8	4.7	7.0	4.7	7.4	4.7	7.8	4.6
43.0	6.0	4.4	6.0	4.4	6.4	4.4	6.6	4.7	6.8	4.6	7.2	4.6	7.6	4.5	
100 (11.2)	20.0	10.9	7.6	11.3	7.8	12.1	7.8	12.5	8.2	12.9	8.1	13.7	8.0	14.5	7.9
	22.5	10.8	7.5	11.2	7.7	11.9	7.7	12.3	8.1	12.7	8.0	13.5	7.9	14.3	7.8
	25.0	10.7	7.5	11.0	7.6	11.7	7.6	12.1	8.0	12.5	7.9	13.2	7.8	14.0	7.7
	27.5	10.5	7.4	10.8	7.5	11.5	7.5	11.8	7.8	12.2	7.8	13.0	7.7	13.7	7.6
	30.0	10.3	7.3	10.6	7.4	11.2	7.4	11.6	7.7	12.0	7.7	12.7	7.6	13.5	7.5
	32.5	10.2	7.2	10.3	7.3	11.0	7.2	11.4	7.6	11.7	7.6	12.4	7.5	13.2	7.4
	35.0	10.0	7.1	10.1	7.2	10.8	7.1	11.2	7.5	11.5	7.5	12.2	7.4	12.9	7.3
	37.5	9.8	7.0	9.9	7.1	10.6	7.0	10.9	7.4	11.2	7.4	11.9	7.3	12.6	7.2
	40.0	9.6	6.9	9.7	7.0	10.3	6.9	10.7	7.3	11.0	7.3	11.7	7.2	12.4	7.1
43.0	9.4	6.8	9.5	6.9	10.1	6.8	10.4	7.2	10.7	7.1	11.4	7.1	12.1	6.9	
125 (14.0)	20.0	13.6	9.4	14.1	9.7	15.1	9.7	15.7	10.2	16.2	10.1	17.2	10.0	18.2	9.8
	22.5	13.6	9.4	14.0	9.6	14.9	9.6	15.4	10.0	15.9	10.0	16.8	9.9	17.8	9.7
	25.0	13.3	9.3	13.7	9.5	14.6	9.4	15.1	9.9	15.6	9.8	16.5	9.7	17.5	9.6
	27.5	13.1	9.2	13.5	9.3	14.3	9.3	14.8	9.8	15.3	9.7	16.2	9.6	17.2	9.4
	30.0	12.9	9.0	13.2	9.2	14.1	9.1	14.5	9.6	15.0	9.6	15.9	9.4	16.8	9.3
	32.5	12.7	8.9	12.9	9.1	13.8	9.0	14.2	9.5	14.7	9.4	15.6	9.3	16.5	9.2
	35.0	12.5	8.8	12.7	8.9	13.5	8.9	14.0	9.4	14.4	9.3	15.2	9.2	16.2	9.0
	37.5	12.3	8.7	12.4	8.8	13.2	8.7	13.6	9.2	14.1	9.2	14.9	9.0	15.8	8.9
	40.0	12.0	8.6	12.2	8.7	12.9	8.6	13.3	9.1	13.8	9.0	14.6	8.9	15.5	8.8
43.0	11.8	8.4	11.8	8.5	12.6	8.4	13.0	8.9	13.4	8.9	14.2	8.8	15.1	8.6	

kcal/h=kW x 860 , BTU/h = kW x 3,412

6. Cooling [Ceiling suspended]

6-3. Cooling capacity with PUHY-RP450-650YSJM

PCFY-P-VKM-E

CA:Capacity(kW) , SHC:Sensible Heat Capacity(kW)

Model size (Rated kW)	Outdoor air temp. °C D.B.	Indoor air temp.													
		21.5°C D.B. 15°C W.B.		23°C D.B. 16°C W.B.		25°C D.B. 18°C W.B.		27°C D.B. 19°C W.B.		28°C D.B. 20°C W.B.		30°C D.B. 22°C W.B.		32°C D.B. 24°C W.B.	
		CA	SHC	CA	SHC	CA	SHC	CA	SHC	CA	SHC	CA	SHC	CA	SHC
40 (4.5)	20.0	4.3	3.1	4.4	3.1	4.7	3.1	4.8	3.3	5.0	3.3	5.3	3.3	5.7	3.2
	22.5	4.2	3.0	4.3	3.1	4.6	3.1	4.8	3.3	4.9	3.3	5.3	3.2	5.6	3.2
	25.0	4.2	3.0	4.3	3.1	4.6	3.1	4.7	3.3	4.9	3.2	5.2	3.2	5.6	3.2
	27.5	4.1	3.0	4.2	3.1	4.5	3.1	4.7	3.2	4.8	3.2	5.2	3.2	5.5	3.2
	30.0	4.1	3.0	4.2	3.0	4.5	3.0	4.6	3.2	4.8	3.2	5.1	3.2	5.5	3.1
	32.5	4.0	3.0	4.1	3.0	4.4	3.0	4.6	3.2	4.7	3.2	5.1	3.2	5.4	3.1
	35.0	4.0	2.9	4.1	3.0	4.4	3.0	4.5	3.2	4.7	3.2	5.0	3.1	5.4	3.1
	37.5	4.0	2.9	4.0	3.0	4.3	3.0	4.5	3.1	4.6	3.1	5.0	3.1	5.3	3.1
	40.0	3.9	2.9	4.0	2.9	4.3	2.9	4.4	3.1	4.6	3.1	4.9	3.1	5.3	3.1
	43.0	3.9	2.9	3.9	2.9	4.2	2.9	4.4	3.1	4.5	3.1	4.9	3.1	5.2	3.0
63 (7.1)	20.0	6.7	4.8	6.9	4.9	7.4	4.9	7.6	5.1	7.9	5.1	8.4	5.1	8.9	5.0
	22.5	6.6	4.7	6.8	4.9	7.3	4.8	7.6	5.1	7.8	5.1	8.3	5.0	8.8	5.0
	25.0	6.6	4.7	6.8	4.8	7.2	4.8	7.5	5.1	7.7	5.0	8.2	5.0	8.8	4.9
	27.5	6.5	4.7	6.7	4.8	7.2	4.8	7.4	5.0	7.6	5.0	8.2	5.0	8.7	4.9
	30.0	6.4	4.6	6.6	4.7	7.1	4.7	7.3	5.0	7.6	5.0	8.1	4.9	8.6	4.9
	32.5	6.4	4.6	6.5	4.7	7.0	4.7	7.2	4.9	7.5	4.9	8.0	4.9	8.5	4.8
	35.0	6.3	4.6	6.4	4.6	6.9	4.6	7.1	4.9	7.4	4.9	7.9	4.9	8.5	4.8
	37.5	6.2	4.5	6.3	4.6	6.8	4.6	7.1	4.9	7.3	4.9	7.8	4.8	8.4	4.8
	40.0	6.2	4.5	6.3	4.6	6.7	4.6	7.0	4.8	7.2	4.8	7.8	4.8	8.3	4.8
	43.0	6.1	4.5	6.2	4.5	6.7	4.5	6.9	4.8	7.1	4.8	7.7	4.8	8.2	4.7
100 (11.2)	20.0	10.6	7.4	10.9	7.6	11.7	7.6	12.0	7.9	12.4	7.9	13.2	7.8	14.1	7.7
	22.5	10.5	7.3	10.8	7.5	11.5	7.5	11.9	7.9	12.3	7.8	13.1	7.8	13.9	7.7
	25.0	10.4	7.3	10.6	7.5	11.4	7.4	11.8	7.8	12.2	7.8	13.0	7.7	13.8	7.6
	27.5	10.3	7.2	10.5	7.4	11.3	7.4	11.7	7.8	12.1	7.7	12.9	7.7	13.7	7.6
	30.0	10.2	7.2	10.4	7.3	11.2	7.3	11.5	7.7	11.9	7.7	12.7	7.6	13.6	7.5
	32.5	10.1	7.1	10.3	7.3	11.0	7.2	11.4	7.6	11.8	7.6	12.6	7.6	13.5	7.5
	35.0	9.9	7.1	10.1	7.2	10.9	7.2	11.2	7.5	11.7	7.6	12.5	7.5	13.3	7.4
	37.5	9.8	7.0	10.0	7.1	10.8	7.1	11.2	7.5	11.6	7.5	12.4	7.5	13.2	7.4
	40.0	9.7	7.0	9.9	7.1	10.6	7.1	11.0	7.5	11.4	7.5	12.2	7.4	13.1	7.3
	43.0	9.6	6.9	9.7	7.0	10.5	7.0	10.9	7.4	11.3	7.4	12.1	7.3	12.9	7.3
125 (14.0)	20.0	13.2	9.2	13.6	9.4	14.6	9.4	15.1	9.9	15.5	9.8	16.5	9.7	17.6	9.6
	22.5	13.1	9.1	13.5	9.3	14.4	9.3	14.9	9.8	15.4	9.8	16.4	9.7	17.4	9.5
	25.0	13.0	9.1	13.3	9.3	14.3	9.2	14.7	9.7	15.2	9.7	16.2	9.6	17.3	9.5
	27.5	12.8	9.0	13.2	9.2	14.1	9.2	14.6	9.6	15.1	9.6	16.1	9.5	17.1	9.4
	30.0	12.7	8.9	13.0	9.1	13.9	9.1	14.4	9.6	14.9	9.5	15.9	9.5	17.0	9.3
	32.5	12.6	8.9	12.8	9.0	13.8	9.0	14.3	9.5	14.8	9.5	15.8	9.4	16.8	9.3
	35.0	12.4	8.8	12.7	8.9	13.6	8.9	14.0	9.4	14.6	9.4	15.6	9.3	16.7	9.2
	37.5	12.3	8.7	12.5	8.9	13.5	8.9	14.0	9.4	14.4	9.3	15.5	9.3	16.5	9.2
	40.0	12.2	8.6	12.4	8.8	13.3	8.8	13.8	9.3	14.3	9.3	15.3	9.2	16.4	9.1
	43.0	12.0	8.6	12.2	8.7	13.1	8.7	13.6	9.2	14.1	9.2	15.1	9.1	16.2	9.0

kcal/h=kW x 860 , BTU/h = kW x 3,412

6. Cooling [Ceiling suspended]

6-4. Cooling capacity with PUHY-RP700-800YSJM

PCFY-P-VKM-E

CA:Capacity(kW) , SHC:Sensible Heat Capacity(kW)

Model size (Rated kW)	Outdoor air temp. °C D.B.	Indoor air temp.													
		21.5°C D.B. 15°C W.B.		23°C D.B. 16°C W.B.		25°C D.B. 18°C W.B.		27°C D.B. 19°C W.B.		28°C D.B. 20°C W.B.		30°C D.B. 22°C W.B.		32°C D.B. 24°C W.B.	
		CA	SHC	CA	SHC	CA	SHC	CA	SHC	CA	SHC	CA	SHC	CA	SHC
40 (4.5)	20.0	4.3	3.1	4.5	3.2	4.8	3.2	5.0	3.4	5.2	3.4	5.5	3.3	5.9	3.3
	22.5	4.3	3.1	4.4	3.2	4.7	3.2	4.9	3.3	5.1	3.3	5.4	3.3	5.8	3.3
	25.0	4.2	3.0	4.3	3.1	4.7	3.1	4.8	3.3	5.0	3.3	5.3	3.3	5.7	3.2
	27.5	4.1	3.0	4.3	3.1	4.6	3.1	4.7	3.3	4.9	3.3	5.2	3.2	5.6	3.2
	30.0	4.1	3.0	4.2	3.1	4.5	3.0	4.7	3.2	4.8	3.2	5.1	3.2	5.5	3.1
	32.5	4.0	2.9	4.1	3.0	4.4	3.0	4.6	3.2	4.7	3.2	5.0	3.1	5.4	3.1
	35.0	3.9	2.9	4.0	3.0	4.3	3.0	4.5	3.2	4.6	3.1	4.9	3.1	5.3	3.1
	37.5	3.8	2.9	4.0	2.9	4.2	2.9	4.4	3.1	4.5	3.1	4.8	3.1	5.2	3.0
	40.0	3.8	2.8	3.9	2.9	4.2	2.9	4.3	3.1	4.5	3.1	4.8	3.0	5.1	3.0
43.0	3.7	2.8	3.8	2.9	4.1	2.8	4.2	3.0	4.3	3.0	4.6	3.0	4.9	2.9	
63 (7.1)	20.0	6.9	4.8	7.1	5.0	7.6	5.0	7.9	5.3	8.2	5.2	8.7	5.2	9.3	5.1
	22.5	6.7	4.8	7.0	4.9	7.5	4.9	7.8	5.2	8.0	5.2	8.6	5.1	9.1	5.1
	25.0	6.6	4.7	6.9	4.9	7.4	4.9	7.6	5.1	7.9	5.1	8.4	5.1	8.9	5.0
	27.5	6.5	4.7	6.7	4.8	7.2	4.8	7.5	5.1	7.7	5.0	8.3	5.0	8.8	4.9
	30.0	6.4	4.6	6.6	4.7	7.1	4.7	7.3	5.0	7.6	5.0	8.1	4.9	8.6	4.9
	32.5	6.3	4.5	6.5	4.7	7.0	4.7	7.2	4.9	7.5	4.9	7.9	4.9	8.5	4.8
	35.0	6.2	4.5	6.4	4.6	6.8	4.6	7.1	4.9	7.3	4.9	7.8	4.8	8.3	4.7
	37.5	6.1	4.4	6.2	4.6	6.7	4.5	6.9	4.8	7.2	4.8	7.6	4.8	8.1	4.7
	40.0	5.9	4.4	6.1	4.5	6.6	4.5	6.8	4.8	7.0	4.7	7.5	4.7	8.0	4.6
43.0	5.8	4.3	6.0	4.4	6.4	4.4	6.6	4.7	6.9	4.7	7.3	4.6	7.8	4.6	
100 (11.2)	20.0	10.8	7.5	11.2	7.7	12.0	7.7	12.5	8.1	12.9	8.1	13.7	8.0	14.6	7.9
	22.5	10.6	7.4	11.0	7.6	11.8	7.6	12.2	8.0	12.6	8.0	13.5	7.9	14.4	7.8
	25.0	10.5	7.3	10.8	7.5	11.6	7.5	12.0	7.9	12.4	7.9	13.3	7.8	14.1	7.7
	27.5	10.3	7.2	10.6	7.4	11.4	7.4	11.8	7.8	12.2	7.8	13.0	7.7	13.8	7.6
	30.0	10.1	7.1	10.4	7.3	11.2	7.3	11.6	7.7	12.0	7.7	12.8	7.6	13.6	7.5
	32.5	9.9	7.0	10.2	7.2	11.0	7.2	11.4	7.6	11.8	7.6	12.5	7.5	13.3	7.4
	35.0	9.7	7.0	10.0	7.1	10.8	7.1	11.2	7.5	11.5	7.5	12.3	7.4	13.1	7.3
	37.5	9.5	6.9	9.8	7.0	10.6	7.0	10.9	7.4	11.3	7.4	12.1	7.3	12.8	7.2
	40.0	9.4	6.8	9.6	6.9	10.4	6.9	10.7	7.3	11.1	7.3	11.8	7.2	12.6	7.1
43.0	9.2	6.7	9.4	6.8	10.1	6.8	10.5	7.2	10.8	7.2	11.5	7.1	12.3	7.0	
125 (14.0)	20.0	13.5	9.4	14.0	9.6	15.0	9.6	15.6	10.1	16.1	10.1	17.2	10.0	18.3	9.9
	22.5	13.3	9.2	13.8	9.5	14.8	9.5	15.3	10.0	15.8	10.0	16.9	9.9	17.9	9.7
	25.0	13.1	9.1	13.5	9.4	14.5	9.4	15.0	9.9	15.5	9.8	16.6	9.7	17.6	9.6
	27.5	12.8	9.0	13.3	9.2	14.3	9.2	14.8	9.7	15.3	9.7	16.3	9.6	17.3	9.5
	30.0	12.6	8.9	13.0	9.1	14.0	9.1	14.5	9.6	15.0	9.6	16.0	9.5	17.0	9.4
	32.5	12.4	8.8	12.8	9.0	13.7	9.0	14.2	9.5	14.7	9.4	15.7	9.4	16.7	9.2
	35.0	12.2	8.6	12.5	8.9	13.5	8.9	14.0	9.4	14.4	9.3	15.4	9.2	16.4	9.1
	37.5	11.9	8.5	12.3	8.7	13.2	8.7	13.7	9.2	14.1	9.2	15.1	9.1	16.0	9.0
	40.0	11.7	8.4	12.1	8.6	12.9	8.6	13.4	9.1	13.9	9.1	14.8	9.0	15.7	8.9
43.0	11.4	8.3	11.8	8.5	12.6	8.5	13.1	9.0	13.5	8.9	14.4	8.8	15.4	8.7	

kcal/h=kW x 860 , BTU/h = kW x 3,412

6. Cooling [Ceiling suspended]

6-5. Cooling capacity with PUHY-RP850-900YSJM

PCFY-P-VKM-E

CA:Capacity(kW) , SHC:Sensible Heat Capacity(kW)

Model size (Rated kW)	Outdoor air temp. °C D.B.	Indoor air temp.													
		21.5°C D.B. 15°C W.B.		23°C D.B. 16°C W.B.		25°C D.B. 18°C W.B.		27°C D.B. 19°C W.B.		28°C D.B. 20°C W.B.		30°C D.B. 22°C W.B.		32°C D.B. 24°C W.B.	
		CA	SHC	CA	SHC	CA	SHC	CA	SHC	CA	SHC	CA	SHC	CA	SHC
40 (4.5)	20.0	4.3	3.1	4.4	3.1	4.7	3.1	4.8	3.3	5.0	3.3	5.3	3.3	5.7	3.2
	22.5	4.2	3.0	4.3	3.1	4.6	3.1	4.8	3.3	4.9	3.3	5.3	3.2	5.6	3.2
	25.0	4.2	3.0	4.3	3.1	4.6	3.1	4.7	3.3	4.9	3.2	5.2	3.2	5.6	3.2
	27.5	4.1	3.0	4.2	3.1	4.5	3.1	4.7	3.2	4.8	3.2	5.2	3.2	5.5	3.2
	30.0	4.1	3.0	4.2	3.0	4.5	3.0	4.6	3.2	4.8	3.2	5.1	3.2	5.5	3.1
	32.5	4.0	3.0	4.1	3.0	4.4	3.0	4.6	3.2	4.7	3.2	5.1	3.2	5.4	3.1
	35.0	4.0	2.9	4.1	3.0	4.4	3.0	4.5	3.2	4.7	3.2	5.0	3.1	5.4	3.1
	37.5	4.0	2.9	4.0	3.0	4.3	3.0	4.5	3.1	4.6	3.1	5.0	3.1	5.3	3.1
	40.0	3.9	2.9	4.0	2.9	4.3	2.9	4.4	3.1	4.6	3.1	4.9	3.1	5.3	3.1
	43.0	3.9	2.9	3.9	2.9	4.2	2.9	4.4	3.1	4.5	3.1	4.9	3.1	5.2	3.0
63 (7.1)	20.0	6.7	4.8	6.9	4.9	7.4	4.9	7.6	5.1	7.9	5.1	8.4	5.1	8.9	5.0
	22.5	6.6	4.7	6.8	4.9	7.3	4.8	7.6	5.1	7.8	5.1	8.3	5.0	8.8	5.0
	25.0	6.6	4.7	6.8	4.8	7.2	4.8	7.5	5.1	7.7	5.0	8.2	5.0	8.8	4.9
	27.5	6.5	4.7	6.7	4.8	7.2	4.8	7.4	5.0	7.6	5.0	8.2	5.0	8.7	4.9
	30.0	6.4	4.6	6.6	4.7	7.1	4.7	7.3	5.0	7.6	5.0	8.1	4.9	8.6	4.9
	32.5	6.4	4.6	6.5	4.7	7.0	4.7	7.2	4.9	7.5	4.9	8.0	4.9	8.5	4.8
	35.0	6.3	4.6	6.4	4.6	6.9	4.6	7.1	4.9	7.4	4.9	7.9	4.9	8.5	4.8
	37.5	6.2	4.5	6.3	4.6	6.8	4.6	7.1	4.9	7.3	4.9	7.8	4.8	8.4	4.8
	40.0	6.2	4.5	6.3	4.6	6.7	4.6	7.0	4.8	7.2	4.8	7.8	4.8	8.3	4.8
	43.0	6.1	4.5	6.2	4.5	6.7	4.5	6.9	4.8	7.1	4.8	7.7	4.8	8.2	4.7
100 (11.2)	20.0	10.6	7.4	10.9	7.6	11.7	7.6	12.0	7.9	12.4	7.9	13.2	7.8	14.1	7.7
	22.5	10.5	7.3	10.8	7.5	11.5	7.5	11.9	7.9	12.3	7.8	13.1	7.8	13.9	7.7
	25.0	10.4	7.3	10.6	7.5	11.4	7.4	11.8	7.8	12.2	7.8	13.0	7.7	13.8	7.6
	27.5	10.3	7.2	10.5	7.4	11.3	7.4	11.7	7.8	12.1	7.7	12.9	7.7	13.7	7.6
	30.0	10.2	7.2	10.4	7.3	11.2	7.3	11.5	7.7	11.9	7.7	12.7	7.6	13.6	7.5
	32.5	10.1	7.1	10.3	7.3	11.0	7.2	11.4	7.6	11.8	7.6	12.6	7.6	13.5	7.5
	35.0	9.9	7.1	10.1	7.2	10.9	7.2	11.2	7.5	11.7	7.6	12.5	7.5	13.3	7.4
	37.5	9.8	7.0	10.0	7.1	10.8	7.1	11.2	7.5	11.6	7.5	12.4	7.5	13.2	7.4
	40.0	9.7	7.0	9.9	7.1	10.6	7.1	11.0	7.5	11.4	7.5	12.2	7.4	13.1	7.3
	43.0	9.6	6.9	9.7	7.0	10.5	7.0	10.9	7.4	11.3	7.4	12.1	7.3	12.9	7.3
125 (14.0)	20.0	13.2	9.2	13.6	9.4	14.6	9.4	15.1	9.9	15.5	9.8	16.5	9.7	17.6	9.6
	22.5	13.1	9.1	13.5	9.3	14.4	9.3	14.9	9.8	15.4	9.8	16.4	9.7	17.4	9.5
	25.0	13.0	9.1	13.3	9.3	14.3	9.2	14.7	9.7	15.2	9.7	16.2	9.6	17.3	9.5
	27.5	12.8	9.0	13.2	9.2	14.1	9.2	14.6	9.6	15.1	9.6	16.1	9.5	17.1	9.4
	30.0	12.7	8.9	13.0	9.1	13.9	9.1	14.4	9.6	14.9	9.5	15.9	9.5	17.0	9.3
	32.5	12.6	8.9	12.8	9.0	13.8	9.0	14.3	9.5	14.8	9.5	15.8	9.4	16.8	9.3
	35.0	12.4	8.8	12.7	8.9	13.6	8.9	14.0	9.4	14.6	9.4	15.6	9.3	16.7	9.2
	37.5	12.3	8.7	12.5	8.9	13.5	8.9	14.0	9.4	14.4	9.3	15.5	9.3	16.5	9.2
	40.0	12.2	8.6	12.4	8.8	13.3	8.8	13.8	9.3	14.3	9.3	15.3	9.2	16.4	9.1
	43.0	12.0	8.6	12.2	8.7	13.1	8.7	13.6	9.2	14.1	9.2	15.1	9.1	16.2	9.0

kcal/h=kW x 860 , BTU/h = kW x 3,412

7. Cooling [Wall mounted]

7-1. Cooling capacity with PUHY,PURY-RP200-250YJM

PKFY-P-VBM-E,VHM-E,VKM-E

CA:Capacity(kW) , SHC:Sensible Heat Capacity(kW)

Model size (Rated kW)	Outdoor air temp. °C D.B.	Indoor air temp.													
		21.5°C D.B. 15°C W.B.		23°C D.B. 16°C W.B.		25°C D.B. 18°C W.B.		27°C D.B. 19°C W.B.		28°C D.B. 20°C W.B.		30°C D.B. 22°C W.B.		32°C D.B. 24°C W.B.	
		CA	SHC	CA	SHC	CA	SHC	CA	SHC	CA	SHC	CA	SHC	CA	SHC
15 (1.7)	20.0	1.6	1.2	1.7	1.2	1.8	1.2	1.8	1.3	1.9	1.2	2.0	1.2	2.1	1.2
	22.5	1.6	1.2	1.7	1.2	1.8	1.2	1.8	1.3	1.9	1.2	2.0	1.2	2.1	1.2
	25.0	1.6	1.2	1.7	1.2	1.8	1.2	1.8	1.3	1.9	1.2	2.0	1.2	2.1	1.2
	27.5	1.6	1.2	1.7	1.2	1.8	1.2	1.8	1.2	1.8	1.2	2.0	1.2	2.1	1.2
	30.0	1.6	1.1	1.6	1.2	1.7	1.2	1.8	1.2	1.8	1.2	1.9	1.2	2.0	1.2
	32.5	1.6	1.1	1.6	1.2	1.7	1.1	1.7	1.2	1.8	1.2	1.9	1.2	2.0	1.2
	35.0	1.5	1.1	1.6	1.1	1.7	1.1	1.7	1.2	1.7	1.2	1.8	1.2	1.9	1.1
	37.5	1.5	1.1	1.5	1.1	1.6	1.1	1.7	1.2	1.7	1.2	1.8	1.1	1.9	1.1
	40.0	1.5	1.1	1.5	1.1	1.6	1.1	1.6	1.2	1.7	1.2	1.8	1.1	1.9	1.1
43.0	1.4	1.1	1.5	1.1	1.6	1.1	1.6	1.1	1.6	1.1	1.7	1.1	1.8	1.1	
20 (2.2)	20.0	2.1	1.5	2.2	1.5	2.3	1.5	2.4	1.6	2.5	1.6	2.6	1.6	2.8	1.6
	22.5	2.1	1.5	2.2	1.5	2.3	1.5	2.4	1.6	2.5	1.6	2.6	1.6	2.8	1.6
	25.0	2.1	1.5	2.2	1.5	2.3	1.5	2.4	1.6	2.4	1.6	2.6	1.6	2.7	1.5
	27.5	2.1	1.5	2.1	1.5	2.3	1.5	2.3	1.6	2.4	1.6	2.5	1.5	2.7	1.5
	30.0	2.0	1.5	2.1	1.5	2.2	1.5	2.3	1.6	2.3	1.5	2.5	1.5	2.6	1.5
	32.5	2.0	1.4	2.1	1.5	2.2	1.5	2.2	1.5	2.3	1.5	2.4	1.5	2.6	1.5
	35.0	2.0	1.4	2.0	1.5	2.1	1.4	2.2	1.5	2.3	1.5	2.4	1.5	2.5	1.5
	37.5	1.9	1.4	2.0	1.4	2.1	1.4	2.2	1.5	2.2	1.5	2.3	1.5	2.5	1.4
	40.0	1.9	1.4	2.0	1.4	2.1	1.4	2.1	1.5	2.2	1.5	2.3	1.4	2.4	1.4
43.0	1.8	1.4	1.9	1.4	2.0	1.4	2.1	1.5	2.1	1.4	2.2	1.4	2.3	1.4	
25 (2.8)	20.0	2.7	1.9	2.8	1.9	2.9	1.9	3.0	2.0	3.1	2.0	3.3	2.0	3.5	2.0
	22.5	2.7	1.9	2.8	1.9	2.9	1.9	3.0	2.0	3.1	2.0	3.3	2.0	3.5	2.0
	25.0	2.7	1.9	2.8	1.9	2.9	1.9	3.0	2.0	3.1	2.0	3.3	2.0	3.5	1.9
	27.5	2.7	1.9	2.7	1.9	2.9	1.9	3.0	2.0	3.0	2.0	3.2	1.9	3.4	1.9
	30.0	2.6	1.8	2.7	1.9	2.8	1.9	2.9	2.0	3.0	1.9	3.2	1.9	3.3	1.9
	32.5	2.6	1.8	2.6	1.9	2.8	1.8	2.9	1.9	2.9	1.9	3.1	1.9	3.3	1.9
	35.0	2.5	1.8	2.6	1.8	2.7	1.8	2.8	1.9	2.9	1.9	3.0	1.9	3.2	1.8
	37.5	2.5	1.8	2.5	1.8	2.7	1.8	2.8	1.9	2.8	1.9	3.0	1.8	3.1	1.8
	40.0	2.4	1.7	2.5	1.8	2.6	1.8	2.7	1.9	2.8	1.8	2.9	1.8	3.1	1.8
43.0	2.4	1.7	2.4	1.8	2.6	1.7	2.6	1.8	2.7	1.8	2.8	1.8	3.0	1.7	
32 (3.6)	20.0	3.4	2.6	3.5	2.7	3.8	2.7	3.9	2.8	4.0	2.8	4.3	2.8	4.6	2.8
	22.5	3.4	2.6	3.5	2.7	3.8	2.7	3.9	2.8	4.0	2.8	4.3	2.8	4.6	2.8
	25.0	3.4	2.6	3.5	2.7	3.8	2.7	3.9	2.8	4.0	2.8	4.2	2.8	4.5	2.7
	27.5	3.4	2.6	3.5	2.7	3.7	2.7	3.8	2.8	3.9	2.8	4.1	2.7	4.4	2.7
	30.0	3.3	2.6	3.4	2.7	3.6	2.6	3.7	2.8	3.8	2.8	4.1	2.7	4.3	2.7
	32.5	3.3	2.5	3.4	2.6	3.6	2.6	3.7	2.8	3.8	2.7	4.0	2.7	4.2	2.6
	35.0	3.2	2.5	3.3	2.6	3.5	2.6	3.6	2.7	3.7	2.7	3.9	2.7	4.1	2.6
	37.5	3.2	2.5	3.3	2.6	3.4	2.5	3.5	2.7	3.6	2.7	3.8	2.6	4.0	2.6
	40.0	3.1	2.5	3.2	2.5	3.4	2.5	3.5	2.7	3.6	2.6	3.7	2.6	3.9	2.6
43.0	3.0	2.4	3.1	2.5	3.3	2.5	3.4	2.6	3.5	2.6	3.6	2.6	3.8	2.5	
40 (4.5)	20.0	4.3	3.2	4.4	3.3	4.7	3.3	4.9	3.5	5.0	3.4	5.3	3.4	5.7	3.4
	22.5	4.3	3.2	4.4	3.3	4.7	3.3	4.9	3.5	5.0	3.4	5.3	3.4	5.7	3.4
	25.0	4.3	3.2	4.4	3.3	4.7	3.3	4.9	3.5	5.0	3.4	5.3	3.4	5.6	3.3
	27.5	4.3	3.2	4.4	3.3	4.6	3.2	4.8	3.4	4.9	3.4	5.2	3.3	5.5	3.3
	30.0	4.2	3.1	4.3	3.2	4.6	3.2	4.7	3.4	4.8	3.4	5.1	3.3	5.4	3.3
	32.5	4.1	3.1	4.2	3.2	4.5	3.2	4.6	3.3	4.7	3.3	5.0	3.3	5.3	3.2
	35.0	4.0	3.1	4.1	3.2	4.4	3.1	4.5	3.3	4.6	3.3	4.9	3.2	5.2	3.2
	37.5	4.0	3.0	4.1	3.1	4.3	3.1	4.4	3.3	4.5	3.2	4.8	3.2	5.0	3.1
	40.0	3.9	3.0	4.0	3.1	4.2	3.1	4.3	3.2	4.4	3.2	4.7	3.1	4.9	3.1
43.0	3.8	3.0	3.9	3.0	4.1	3.0	4.2	3.2	4.3	3.2	4.5	3.1	4.8	3.1	
50 (5.6)	20.0	5.3	3.8	5.5	3.9	5.9	3.9	6.1	4.1	6.2	4.0	6.6	4.0	7.1	4.0
	22.5	5.3	3.8	5.5	3.9	5.9	3.9	6.1	4.1	6.2	4.0	6.6	4.0	7.1	4.0
	25.0	5.3	3.8	5.5	3.9	5.9	3.9	6.0	4.1	6.2	4.0	6.6	4.0	7.0	3.9
	27.5	5.3	3.8	5.5	3.9	5.8	3.8	5.9	4.0	6.1	4.0	6.4	3.9	6.8	3.9
	30.0	5.2	3.7	5.4	3.8	5.7	3.8	5.8	4.0	6.0	3.9	6.3	3.9	6.7	3.8
	32.5	5.1	3.7	5.3	3.8	5.6	3.7	5.7	3.9	5.9	3.9	6.2	3.8	6.6	3.8
	35.0	5.0	3.6	5.2	3.7	5.5	3.7	5.6	3.9	5.8	3.8	6.1	3.8	6.4	3.7
	37.5	4.9	3.6	5.1	3.7	5.4	3.6	5.5	3.8	5.6	3.8	5.9	3.7	6.3	3.7
	40.0	4.8	3.5	5.0	3.6	5.3	3.6	5.4	3.8	5.5	3.7	5.8	3.7	6.1	3.6
43.0	4.7	3.5	4.8	3.6	5.1	3.5	5.3	3.7	5.4	3.7	5.6	3.6	6.0	3.5	
63 (7.1)	20.0	6.7	5.2	7.0	5.4	7.5	5.3	7.7	5.7	7.9	5.6	8.4	5.6	9.0	5.5
	22.5	6.7	5.2	7.0	5.4	7.5	5.3	7.7	5.7	7.9	5.6	8.4	5.6	9.0	5.5
	25.0	6.7	5.2	7.0	5.4	7.5	5.3	7.7	5.7	7.9	5.6	8.3	5.5	8.8	5.5
	27.5	6.7	5.2	6.9	5.3	7.3	5.3	7.5	5.6	7.7	5.5	8.1	5.5	8.7	5.4
	30.0	6.6	5.1	6.8	5.3	7.2	5.2	7.4	5.5	7.6	5.5	8.0	5.4	8.5	5.3
	32.5	6.5	5.1	6.7	5.2	7.1	5.2	7.2	5.5	7.4	5.4	7.8	5.3	8.3	5.3
	35.0	6.4	5.0	6.5	5.2	6.9	5.1	7.1	5.4	7.3	5.4	7.7	5.3	8.1	5.2
	37.5	6.2	4.9	6.4	5.1	6.8	5.0	7.0	5.4	7.2	5.3	7.5	5.2	8.0	5.1
	40.0	6.1	4.9	6.3	5.0	6.7	5.0	6.8	5.3	7.0	5.3	7.4	5.2	7.8	5.1
43.0	6.0	4.8	6.1	5.0	6.5	4.9	6.7	5.2	6.9	5.2	7.2	5.1	7.6	5.0	

kcal/h=kW x 860 , BTU/h = kW x 3,412

7. Cooling [Wall mounted]

PKFY-P-VBM-E,VHM-E,VKM-E

CA:Capacity(kW) , SHC:Sensible Heat Capacity(kW)

Model size (Rated kW)	Outdoor air temp. °C D.B.	Indoor air temp.													
		21.5°C D.B. 15°C W.B.		23°C D.B. 16°C W.B.		25°C D.B. 18°C W.B.		27°C D.B. 19°C W.B.		28°C D.B. 20°C W.B.		30°C D.B. 22°C W.B.		32°C D.B. 24°C W.B.	
		CA	SHC	CA	SHC	CA	SHC	CA	SHC	CA	SHC	CA	SHC	CA	SHC
100 (11.2)	20.0	10.6	7.6	11.0	7.9	11.8	7.8	12.1	8.2	12.5	8.2	13.2	8.1	14.2	8.0
	22.5	10.6	7.6	11.0	7.9	11.8	7.8	12.1	8.2	12.5	8.2	13.2	8.1	14.2	8.0
	25.0	10.6	7.6	11.0	7.9	11.8	7.8	12.1	8.2	12.4	8.1	13.1	8.0	13.9	7.9
	27.5	10.6	7.6	10.9	7.8	11.6	7.7	11.9	8.1	12.2	8.0	12.9	7.9	13.7	7.8
	30.0	10.4	7.5	10.7	7.7	11.3	7.6	11.6	8.0	12.0	7.9	12.6	7.8	13.4	7.7
	32.5	10.2	7.4	10.5	7.6	11.1	7.5	11.4	7.9	11.7	7.9	12.4	7.7	13.1	7.6
	35.0	10.0	7.3	10.3	7.5	10.9	7.4	11.2	7.8	11.5	7.8	12.1	7.6	12.8	7.5
	37.5	9.8	7.2	10.1	7.4	10.7	7.3	11.0	7.7	11.3	7.7	11.9	7.5	12.6	7.4
	40.0	9.6	7.1	9.9	7.3	10.5	7.2	10.8	7.6	11.1	7.6	11.6	7.4	12.3	7.3
	43.0	9.4	7.0	9.7	7.2	10.2	7.1	10.5	7.5	10.8	7.5	11.3	7.3	12.0	7.2

kcal/h=kW x 860 , BTU/h = kW x 3,412

7. Cooling [Wall mounted]

7-2. Cooling capacity with PUHY-RP300-400Y(S)JM,PURY-RP300YJM

PKFY-P-VBM-E,VHM-E,VKM-E

CA:Capacity(kW) , SHC:Sensible Heat Capacity(kW)

Model size (Rated kW)	Outdoor air temp. °C D.B.	Indoor air temp.													
		21.5°C D.B. 15°C W.B.		23°C D.B. 16°C W.B.		25°C D.B. 18°C W.B.		27°C D.B. 19°C W.B.		28°C D.B. 20°C W.B.		30°C D.B. 22°C W.B.		32°C D.B. 24°C W.B.	
		CA	SHC	CA	SHC	CA	SHC	CA	SHC	CA	SHC	CA	SHC	CA	SHC
15 (1.7)	20.0	1.7	1.2	1.7	1.2	1.8	1.2	1.9	1.3	2.0	1.3	2.1	1.3	2.2	1.2
	22.5	1.6	1.2	1.7	1.2	1.8	1.2	1.9	1.3	1.9	1.3	2.0	1.2	2.2	1.2
	25.0	1.6	1.2	1.7	1.2	1.8	1.2	1.8	1.3	1.9	1.2	2.0	1.2	2.1	1.2
	27.5	1.6	1.2	1.6	1.2	1.7	1.2	1.8	1.2	1.9	1.2	2.0	1.2	2.1	1.2
	30.0	1.6	1.1	1.6	1.2	1.7	1.2	1.8	1.2	1.8	1.2	1.9	1.2	2.0	1.2
	32.5	1.5	1.1	1.6	1.1	1.7	1.1	1.7	1.2	1.8	1.2	1.9	1.2	2.0	1.2
	35.0	1.5	1.1	1.5	1.1	1.6	1.1	1.7	1.2	1.7	1.2	1.9	1.2	2.0	1.2
	37.5	1.5	1.1	1.5	1.1	1.6	1.1	1.7	1.2	1.7	1.2	1.8	1.2	1.9	1.1
	40.0	1.5	1.1	1.5	1.1	1.6	1.1	1.6	1.2	1.7	1.2	1.8	1.1	1.9	1.1
43.0	1.4	1.1	1.4	1.1	1.5	1.1	1.6	1.1	1.6	1.1	1.7	1.1	1.8	1.1	
20 (2.2)	20.0	2.1	1.5	2.2	1.6	2.4	1.6	2.5	1.6	2.5	1.6	2.7	1.6	2.9	1.6
	22.5	2.1	1.5	2.2	1.5	2.3	1.5	2.4	1.6	2.5	1.6	2.6	1.6	2.8	1.6
	25.0	2.1	1.5	2.2	1.5	2.3	1.5	2.4	1.6	2.4	1.6	2.6	1.6	2.8	1.5
	27.5	2.1	1.5	2.1	1.5	2.3	1.5	2.3	1.6	2.4	1.6	2.5	1.5	2.7	1.5
	30.0	2.0	1.5	2.1	1.5	2.2	1.5	2.3	1.6	2.4	1.5	2.5	1.5	2.6	1.5
	32.5	2.0	1.4	2.0	1.5	2.2	1.5	2.2	1.5	2.3	1.5	2.4	1.5	2.6	1.5
	35.0	2.0	1.4	2.0	1.4	2.1	1.4	2.2	1.5	2.3	1.5	2.4	1.5	2.5	1.5
	37.5	1.9	1.4	2.0	1.4	2.1	1.4	2.1	1.5	2.2	1.5	2.3	1.5	2.5	1.4
	40.0	1.9	1.4	1.9	1.4	2.0	1.4	2.1	1.5	2.2	1.5	2.3	1.4	2.4	1.4
43.0	1.9	1.4	1.9	1.4	2.0	1.4	2.0	1.4	2.1	1.4	2.2	1.4	2.4	1.4	
25 (2.8)	20.0	2.7	1.9	2.8	2.0	3.0	2.0	3.1	2.1	3.2	2.1	3.4	2.0	3.6	2.0
	22.5	2.7	1.9	2.8	1.9	3.0	1.9	3.1	2.0	3.2	2.0	3.4	2.0	3.6	2.0
	25.0	2.7	1.9	2.7	1.9	2.9	1.9	3.0	2.0	3.1	2.0	3.3	2.0	3.5	1.9
	27.5	2.6	1.9	2.7	1.9	2.9	1.9	3.0	2.0	3.1	2.0	3.2	1.9	3.4	1.9
	30.0	2.6	1.8	2.6	1.9	2.8	1.9	2.9	2.0	3.0	1.9	3.2	1.9	3.4	1.9
	32.5	2.5	1.8	2.6	1.8	2.8	1.8	2.8	1.9	2.9	1.9	3.1	1.9	3.3	1.9
	35.0	2.5	1.8	2.5	1.8	2.7	1.8	2.8	1.9	2.9	1.9	3.0	1.9	3.2	1.8
	37.5	2.5	1.8	2.5	1.8	2.6	1.8	2.7	1.9	2.8	1.9	3.0	1.8	3.2	1.8
	40.0	2.4	1.7	2.4	1.8	2.6	1.7	2.7	1.8	2.8	1.8	2.9	1.8	3.1	1.8
43.0	2.4	1.7	2.4	1.7	2.5	1.7	2.6	1.8	2.7	1.8	2.8	1.8	3.0	1.8	
32 (3.6)	20.0	3.5	2.7	3.6	2.7	3.9	2.7	4.0	2.9	4.2	2.9	4.4	2.9	4.7	2.8
	22.5	3.5	2.6	3.6	2.7	3.8	2.7	4.0	2.9	4.1	2.9	4.3	2.8	4.6	2.8
	25.0	3.4	2.6	3.5	2.7	3.8	2.7	3.9	2.8	4.0	2.8	4.2	2.8	4.5	2.7
	27.5	3.4	2.6	3.5	2.7	3.7	2.6	3.8	2.8	3.9	2.8	4.2	2.8	4.4	2.7
	30.0	3.3	2.6	3.4	2.6	3.6	2.6	3.7	2.8	3.8	2.8	4.1	2.7	4.3	2.7
	32.5	3.3	2.5	3.3	2.6	3.5	2.6	3.7	2.7	3.8	2.7	4.0	2.7	4.2	2.7
	35.0	3.2	2.5	3.3	2.6	3.5	2.5	3.6	2.7	3.7	2.7	3.9	2.7	4.2	2.6
	37.5	3.2	2.5	3.2	2.5	3.4	2.5	3.5	2.7	3.6	2.7	3.8	2.6	4.1	2.6
	40.0	3.1	2.5	3.1	2.5	3.3	2.5	3.4	2.7	3.5	2.6	3.8	2.6	4.0	2.6
43.0	3.0	2.4	3.0	2.5	3.2	2.4	3.3	2.6	3.4	2.6	3.7	2.6	3.9	2.5	
40 (4.5)	20.0	4.4	3.2	4.5	3.3	4.9	3.3	5.0	3.5	5.2	3.5	5.5	3.5	5.8	3.4
	22.5	4.4	3.2	4.5	3.3	4.8	3.3	4.9	3.5	5.1	3.5	5.4	3.4	5.7	3.4
	25.0	4.3	3.2	4.4	3.3	4.7	3.3	4.9	3.5	5.0	3.4	5.3	3.4	5.6	3.3
	27.5	4.2	3.2	4.3	3.2	4.6	3.2	4.8	3.4	4.9	3.4	5.2	3.4	5.5	3.3
	30.0	4.1	3.1	4.2	3.2	4.5	3.2	4.7	3.4	4.8	3.4	5.1	3.3	5.4	3.3
	32.5	4.1	3.1	4.2	3.2	4.4	3.1	4.6	3.3	4.7	3.3	5.0	3.3	5.3	3.2
	35.0	4.0	3.1	4.1	3.1	4.3	3.1	4.5	3.3	4.6	3.3	4.9	3.2	5.2	3.2
	37.5	3.9	3.0	4.0	3.1	4.2	3.1	4.4	3.3	4.5	3.2	4.8	3.2	5.1	3.2
	40.0	3.9	3.0	3.9	3.0	4.2	3.0	4.3	3.2	4.4	3.2	4.7	3.2	5.0	3.1
43.0	3.8	3.0	3.8	3.0	4.0	3.0	4.2	3.2	4.3	3.2	4.6	3.1	4.8	3.1	
50 (5.6)	20.0	5.4	3.8	5.6	4.0	6.1	4.0	6.3	4.2	6.5	4.2	6.9	4.1	7.3	4.0
	22.5	5.4	3.8	5.6	3.9	6.0	3.9	6.2	4.1	6.3	4.1	6.7	4.0	7.1	4.0
	25.0	5.3	3.8	5.5	3.9	5.8	3.9	6.0	4.1	6.2	4.0	6.6	4.0	7.0	3.9
	27.5	5.3	3.7	5.4	3.8	5.7	3.8	5.9	4.0	6.1	4.0	6.5	3.9	6.9	3.9
	30.0	5.2	3.7	5.3	3.8	5.6	3.7	5.8	4.0	6.0	3.9	6.4	3.9	6.7	3.8
	32.5	5.1	3.7	5.2	3.7	5.5	3.7	5.7	3.9	5.9	3.9	6.2	3.8	6.6	3.8
	35.0	5.0	3.6	5.1	3.7	5.4	3.6	5.6	3.9	5.7	3.8	6.1	3.8	6.5	3.7
	37.5	4.9	3.6	5.0	3.6	5.3	3.6	5.5	3.8	5.6	3.8	6.0	3.7	6.3	3.7
	40.0	4.8	3.5	4.9	3.6	5.2	3.5	5.3	3.7	5.5	3.7	5.8	3.7	6.2	3.6
43.0	4.7	3.5	4.7	3.5	5.0	3.5	5.2	3.7	5.4	3.7	5.7	3.6	6.0	3.6	
63 (7.1)	20.0	6.9	5.3	7.1	5.4	7.7	5.4	7.9	5.8	8.2	5.7	8.7	5.7	9.2	5.6
	22.5	6.9	5.3	7.1	5.4	7.6	5.4	7.8	5.7	8.0	5.7	8.5	5.6	9.1	5.5
	25.0	6.8	5.2	7.0	5.4	7.4	5.3	7.7	5.7	7.9	5.6	8.4	5.6	8.9	5.5
	27.5	6.7	5.2	6.8	5.3	7.3	5.3	7.5	5.6	7.7	5.6	8.2	5.5	8.7	5.4
	30.0	6.5	5.1	6.7	5.2	7.1	5.2	7.4	5.5	7.6	5.5	8.1	5.4	8.5	5.3
	32.5	6.4	5.0	6.6	5.2	7.0	5.1	7.2	5.5	7.4	5.4	7.9	5.4	8.4	5.3
	35.0	6.3	5.0	6.4	5.1	6.8	5.1	7.1	5.4	7.3	5.4	7.7	5.3	8.2	5.2
	37.5	6.2	4.9	6.3	5.0	6.7	5.0	6.9	5.3	7.1	5.3	7.6	5.2	8.0	5.2
	40.0	6.1	4.9	6.2	5.0	6.6	4.9	6.8	5.3	7.0	5.3	7.4	5.2	7.8	5.1
43.0	6.0	4.8	6.0	4.9	6.4	4.9	6.6	5.2	6.8	5.2	7.2	5.1	7.6	5.0	

kcal/h=kW x 860 , BTU/h = kW x 3,412

7. Cooling [Wall mounted]

PKFY-P-VBM-E,VHM-E,VKM-E

CA:Capacity(kW) , SHC:Sensible Heat Capacity(kW)

Model size (Rated kW)	Outdoor air temp. °C D.B.	Indoor air temp.													
		21.5°C D.B. 15°C W.B.		23°C D.B. 16°C W.B.		25°C D.B. 18°C W.B.		27°C D.B. 19°C W.B.		28°C D.B. 20°C W.B.		30°C D.B. 22°C W.B.		32°C D.B. 24°C W.B.	
		CA	SHC	CA	SHC	CA	SHC	CA	SHC	CA	SHC	CA	SHC	CA	SHC
100 (11.2)	20.0	10.9	7.8	11.3	8.0	12.1	8.0	12.5	8.4	12.9	8.4	13.7	8.3	14.5	8.1
	22.5	10.8	7.7	11.2	7.9	11.9	7.9	12.3	8.3	12.7	8.3	13.5	8.2	14.3	8.0
	25.0	10.7	7.6	11.0	7.8	11.7	7.8	12.1	8.2	12.5	8.2	13.2	8.1	14.0	7.9
	27.5	10.5	7.6	10.8	7.7	11.5	7.7	11.8	8.1	12.2	8.1	13.0	8.0	13.7	7.8
	30.0	10.3	7.5	10.6	7.6	11.2	7.6	11.6	8.0	12.0	8.0	12.7	7.9	13.5	7.7
	32.5	10.2	7.4	10.3	7.5	11.0	7.5	11.4	7.9	11.7	7.9	12.4	7.8	13.2	7.6
	35.0	10.0	7.3	10.1	7.4	10.8	7.4	11.2	7.8	11.5	7.8	12.2	7.6	12.9	7.5
	37.5	9.8	7.2	9.9	7.3	10.6	7.3	10.9	7.7	11.2	7.6	11.9	7.5	12.6	7.4
	40.0	9.6	7.1	9.7	7.2	10.3	7.2	10.7	7.6	11.0	7.5	11.7	7.4	12.4	7.3
	43.0	9.4	7.0	9.5	7.1	10.1	7.0	10.4	7.5	10.7	7.4	11.4	7.3	12.1	7.2

kcal/h=kW x 860 , BTU/h = kW x 3,412

7. Cooling [Wall mounted]

7-3. Cooling capacity with PUHY-RP450-650YSJM

PKFY-P-VBM-E,VHM-E,VKM-E

CA:Capacity(kW) , SHC:Sensible Heat Capacity(kW)

Model size (Rated kW)	Outdoor air temp. °C D.B.	Indoor air temp.													
		21.5°C D.B. 15°C W.B.		23°C D.B. 16°C W.B.		25°C D.B. 18°C W.B.		27°C D.B. 19°C W.B.		28°C D.B. 20°C W.B.		30°C D.B. 22°C W.B.		32°C D.B. 24°C W.B.	
		CA	SHC	CA	SHC	CA	SHC	CA	SHC	CA	SHC	CA	SHC	CA	SHC
15 (1.7)	20.0	1.6	1.2	1.7	1.2	1.8	1.2	1.8	1.3	1.9	1.2	2.0	1.2	2.1	1.2
	22.5	1.6	1.2	1.6	1.2	1.8	1.2	1.8	1.2	1.9	1.2	2.0	1.2	2.1	1.2
	25.0	1.6	1.1	1.6	1.2	1.7	1.2	1.8	1.2	1.8	1.2	2.0	1.2	2.1	1.2
	27.5	1.6	1.1	1.6	1.2	1.7	1.2	1.8	1.2	1.8	1.2	2.0	1.2	2.1	1.2
	30.0	1.5	1.1	1.6	1.2	1.7	1.1	1.8	1.2	1.8	1.2	1.9	1.2	2.1	1.2
	32.5	1.5	1.1	1.6	1.1	1.7	1.1	1.7	1.2	1.8	1.2	1.9	1.2	2.0	1.2
	35.0	1.5	1.1	1.5	1.1	1.7	1.1	1.7	1.2	1.8	1.2	1.9	1.2	2.0	1.2
	37.5	1.5	1.1	1.5	1.1	1.6	1.1	1.7	1.2	1.8	1.2	1.9	1.2	2.0	1.2
	40.0	1.5	1.1	1.5	1.1	1.6	1.1	1.7	1.2	1.7	1.2	1.9	1.2	2.0	1.2
43.0	1.5	1.1	1.5	1.1	1.6	1.1	1.7	1.2	1.7	1.2	1.8	1.2	2.0	1.2	
20 (2.2)	20.0	2.1	1.5	2.1	1.5	2.3	1.5	2.4	1.6	2.4	1.6	2.6	1.6	2.8	1.5
	22.5	2.1	1.5	2.1	1.5	2.3	1.5	2.3	1.6	2.4	1.6	2.6	1.6	2.7	1.5
	25.0	2.0	1.5	2.1	1.5	2.2	1.5	2.3	1.6	2.4	1.6	2.5	1.6	2.7	1.5
	27.5	2.0	1.4	2.1	1.5	2.2	1.5	2.3	1.6	2.4	1.6	2.5	1.5	2.7	1.5
	30.0	2.0	1.4	2.0	1.5	2.2	1.5	2.3	1.6	2.3	1.5	2.5	1.5	2.7	1.5
	32.5	2.0	1.4	2.0	1.5	2.2	1.5	2.2	1.5	2.3	1.5	2.5	1.5	2.6	1.5
	35.0	2.0	1.4	2.0	1.4	2.1	1.4	2.2	1.5	2.3	1.5	2.5	1.5	2.6	1.5
	37.5	1.9	1.4	2.0	1.4	2.1	1.4	2.2	1.5	2.3	1.5	2.4	1.5	2.6	1.5
	40.0	1.9	1.4	1.9	1.4	2.1	1.4	2.2	1.5	2.2	1.5	2.4	1.5	2.6	1.5
43.0	1.9	1.4	1.9	1.4	2.1	1.4	2.1	1.5	2.2	1.5	2.4	1.5	2.5	1.5	
25 (2.8)	20.0	2.6	1.9	2.7	1.9	2.9	1.9	3.0	2.0	3.1	2.0	3.3	2.0	3.5	1.9
	22.5	2.6	1.9	2.7	1.9	2.9	1.9	3.0	2.0	3.1	2.0	3.3	2.0	3.5	1.9
	25.0	2.6	1.8	2.7	1.9	2.9	1.9	2.9	2.0	3.0	2.0	3.2	1.9	3.5	1.9
	27.5	2.6	1.8	2.6	1.9	2.8	1.9	2.9	2.0	3.0	2.0	3.2	1.9	3.4	1.9
	30.0	2.5	1.8	2.6	1.8	2.8	1.8	2.9	1.9	3.0	1.9	3.2	1.9	3.4	1.9
	32.5	2.5	1.8	2.6	1.8	2.8	1.8	2.9	1.9	3.0	1.9	3.2	1.9	3.4	1.9
	35.0	2.5	1.8	2.5	1.8	2.7	1.8	2.8	1.9	2.9	1.9	3.1	1.9	3.3	1.9
	37.5	2.5	1.8	2.5	1.8	2.7	1.8	2.8	1.9	2.9	1.9	3.1	1.9	3.3	1.9
	40.0	2.4	1.8	2.5	1.8	2.7	1.8	2.8	1.9	2.9	1.9	3.1	1.9	3.3	1.9
43.0	2.4	1.7	2.4	1.8	2.6	1.8	2.7	1.9	2.8	1.9	3.0	1.9	3.2	1.8	
32 (3.6)	20.0	3.4	2.6	3.5	2.7	3.7	2.7	3.9	2.8	4.0	2.8	4.3	2.8	4.5	2.8
	22.5	3.4	2.6	3.5	2.7	3.7	2.7	3.8	2.8	4.0	2.8	4.2	2.8	4.5	2.7
	25.0	3.3	2.6	3.4	2.6	3.7	2.6	3.8	2.8	3.9	2.8	4.2	2.8	4.4	2.7
	27.5	3.3	2.6	3.4	2.6	3.6	2.6	3.8	2.8	3.9	2.8	4.1	2.7	4.4	2.7
	30.0	3.3	2.5	3.3	2.6	3.6	2.6	3.7	2.8	3.8	2.8	4.1	2.7	4.4	2.7
	32.5	3.2	2.5	3.3	2.6	3.5	2.6	3.7	2.8	3.8	2.7	4.1	2.7	4.3	2.7
	35.0	3.2	2.5	3.3	2.6	3.5	2.6	3.6	2.7	3.8	2.7	4.0	2.7	4.3	2.7
	37.5	3.2	2.5	3.2	2.6	3.5	2.5	3.6	2.7	3.7	2.7	4.0	2.7	4.2	2.7
	40.0	3.1	2.5	3.2	2.5	3.4	2.5	3.5	2.7	3.7	2.7	3.9	2.7	4.2	2.6
43.0	3.1	2.5	3.1	2.5	3.4	2.5	3.5	2.7	3.6	2.7	3.9	2.7	4.2	2.6	
40 (4.5)	20.0	4.3	3.2	4.4	3.3	4.7	3.3	4.8	3.5	5.0	3.4	5.3	3.4	5.7	3.4
	22.5	4.2	3.2	4.3	3.2	4.6	3.2	4.8	3.4	4.9	3.4	5.3	3.4	5.6	3.3
	25.0	4.2	3.1	4.3	3.2	4.6	3.2	4.7	3.4	4.9	3.4	5.2	3.4	5.6	3.3
	27.5	4.1	3.1	4.2	3.2	4.5	3.2	4.7	3.4	4.8	3.4	5.2	3.3	5.5	3.3
	30.0	4.1	3.1	4.2	3.2	4.5	3.2	4.6	3.4	4.8	3.4	5.1	3.3	5.5	3.3
	32.5	4.0	3.1	4.1	3.2	4.4	3.1	4.6	3.3	4.7	3.3	5.1	3.3	5.4	3.3
	35.0	4.0	3.1	4.1	3.1	4.4	3.1	4.5	3.3	4.7	3.3	5.0	3.3	5.4	3.2
	37.5	4.0	3.0	4.0	3.1	4.3	3.1	4.5	3.3	4.6	3.3	5.0	3.3	5.3	3.2
	40.0	3.9	3.0	4.0	3.1	4.3	3.1	4.4	3.3	4.6	3.3	4.9	3.2	5.3	3.2
43.0	3.9	3.0	3.9	3.1	4.2	3.1	4.4	3.3	4.5	3.2	4.9	3.2	5.2	3.2	
50 (5.6)	20.0	5.3	3.8	5.5	3.9	5.8	3.8	6.0	4.1	6.2	4.0	6.6	4.0	7.0	3.9
	22.5	5.2	3.7	5.4	3.8	5.8	3.8	6.0	4.0	6.2	4.0	6.6	4.0	7.0	3.9
	25.0	5.2	3.7	5.3	3.8	5.7	3.8	5.9	4.0	6.1	4.0	6.5	3.9	6.9	3.9
	27.5	5.1	3.7	5.3	3.8	5.6	3.8	5.8	4.0	6.0	4.0	6.4	3.9	6.9	3.9
	30.0	5.1	3.7	5.2	3.7	5.6	3.7	5.8	3.9	6.0	3.9	6.4	3.9	6.8	3.8
	32.5	5.0	3.6	5.1	3.7	5.5	3.7	5.7	3.9	5.9	3.9	6.3	3.9	6.7	3.8
	35.0	5.0	3.6	5.1	3.7	5.4	3.7	5.6	3.9	5.8	3.9	6.2	3.8	6.7	3.8
	37.5	4.9	3.6	5.0	3.6	5.4	3.6	5.6	3.9	5.8	3.8	6.2	3.8	6.6	3.8
	40.0	4.9	3.5	4.9	3.6	5.3	3.6	5.5	3.8	5.7	3.8	6.1	3.8	6.5	3.8
43.0	4.8	3.5	4.9	3.6	5.2	3.6	5.4	3.8	5.6	3.8	6.0	3.8	6.5	3.7	
63 (7.1)	20.0	6.7	5.2	6.9	5.3	7.4	5.3	7.6	5.6	7.9	5.6	8.4	5.6	8.9	5.5
	22.5	6.6	5.1	6.8	5.3	7.3	5.3	7.6	5.6	7.8	5.6	8.3	5.5	8.8	5.5
	25.0	6.6	5.1	6.8	5.3	7.2	5.2	7.5	5.6	7.7	5.6	8.2	5.5	8.8	5.4
	27.5	6.5	5.1	6.7	5.2	7.2	5.2	7.4	5.5	7.6	5.5	8.2	5.5	8.7	5.4
	30.0	6.4	5.0	6.6	5.2	7.1	5.2	7.3	5.5	7.6	5.5	8.1	5.4	8.6	5.4
	32.5	6.4	5.0	6.5	5.1	7.0	5.1	7.2	5.5	7.5	5.5	8.0	5.4	8.5	5.3
	35.0	6.3	5.0	6.4	5.1	6.9	5.1	7.1	5.4	7.4	5.4	7.9	5.4	8.5	5.3
	37.5	6.2	5.0	6.3	5.1	6.8	5.1	7.1	5.4	7.3	5.4	7.8	5.3	8.4	5.3
	40.0	6.2	4.9	6.3	5.0	6.7	5.0	7.0	5.4	7.2	5.4	7.8	5.3	8.3	5.3
43.0	6.1	4.9	6.2	5.0	6.7	5.0	6.9	5.3	7.1	5.3	7.7	5.3	8.2	5.2	

kcal/h=kW x 860 , BTU/h = kW x 3,412

7. Cooling [Wall mounted]

PKFY-P-VBM-E,VHM-E,VKM-E

CA:Capacity(kW) , SHC:Sensible Heat Capacity(kW)

Model size (Rated kW)	Outdoor air temp. °C D.B.	Indoor air temp.													
		21.5°C D.B. 15°C W.B.		23°C D.B. 16°C W.B.		25°C D.B. 18°C W.B.		27°C D.B. 19°C W.B.		28°C D.B. 20°C W.B.		30°C D.B. 22°C W.B.		32°C D.B. 24°C W.B.	
		CA	SHC	CA	SHC	CA	SHC	CA	SHC	CA	SHC	CA	SHC	CA	SHC
100 (11.2)	20.0	10.6	7.6	10.9	7.8	11.7	7.8	12.0	8.2	12.4	8.2	13.2	8.1	14.1	8.0
	22.5	10.5	7.5	10.8	7.7	11.5	7.7	11.9	8.1	12.3	8.1	13.1	8.0	13.9	7.9
	25.0	10.4	7.5	10.6	7.7	11.4	7.6	11.8	8.1	12.2	8.0	13.0	8.0	13.8	7.9
	27.5	10.3	7.4	10.5	7.6	11.3	7.6	11.7	8.0	12.1	8.0	12.9	7.9	13.7	7.8
	30.0	10.2	7.4	10.4	7.5	11.2	7.5	11.5	8.0	11.9	7.9	12.7	7.9	13.6	7.8
	32.5	10.1	7.3	10.3	7.5	11.0	7.5	11.4	7.9	11.8	7.9	12.6	7.8	13.5	7.7
	35.0	9.9	7.3	10.1	7.4	10.9	7.4	11.2	7.8	11.7	7.8	12.5	7.8	13.3	7.7
	37.5	9.8	7.2	10.0	7.4	10.8	7.4	11.2	7.8	11.6	7.8	12.4	7.7	13.2	7.6
	40.0	9.7	7.2	9.9	7.3	10.6	7.3	11.0	7.7	11.4	7.7	12.2	7.7	13.1	7.6
	43.0	9.6	7.1	9.7	7.2	10.5	7.2	10.9	7.7	11.3	7.7	12.1	7.6	12.9	7.5

kcal/h=kW x 860 , BTU/h = kW x 3,412

7. Cooling [Wall mounted]

7-4. Cooling capacity with PUHY-RP700-800YSJM

PKFY-P-VBM-E,VHM-E,VKM-E

CA:Capacity(kW) , SHC:Sensible Heat Capacity(kW)

Model size (Rated kW)	Outdoor air temp.	Indoor air temp.													
		21.5°C D.B. 15°C W.B.		23°C D.B. 16°C W.B.		25°C D.B. 18°C W.B.		27°C D.B. 19°C W.B.		28°C D.B. 20°C W.B.		30°C D.B. 22°C W.B.		32°C D.B. 24°C W.B.	
		°C D.B.	CA	SHC	CA	SHC	CA	SHC	CA	SHC	CA	SHC	CA	SHC	CA
15 (1.7)	20.0	1.6	1.2	1.7	1.2	1.8	1.2	1.9	1.3	2.0	1.3	2.1	1.3	2.2	1.2
	22.5	1.6	1.2	1.7	1.2	1.8	1.2	1.9	1.3	1.9	1.3	2.0	1.2	2.2	1.2
	25.0	1.6	1.1	1.6	1.2	1.8	1.2	1.8	1.2	1.9	1.2	2.0	1.2	2.1	1.2
	27.5	1.6	1.1	1.6	1.2	1.7	1.2	1.8	1.2	1.9	1.2	2.0	1.2	2.1	1.2
	30.0	1.5	1.1	1.6	1.2	1.7	1.2	1.8	1.2	1.8	1.2	1.9	1.2	2.1	1.2
	32.5	1.5	1.1	1.6	1.1	1.7	1.1	1.7	1.2	1.8	1.2	1.9	1.2	2.0	1.2
	35.0	1.5	1.1	1.5	1.1	1.6	1.1	1.7	1.2	1.8	1.2	1.9	1.2	2.0	1.2
	37.5	1.4	1.1	1.5	1.1	1.6	1.1	1.7	1.2	1.7	1.2	1.8	1.2	1.9	1.1
	40.0	1.4	1.1	1.5	1.1	1.6	1.1	1.6	1.2	1.7	1.2	1.8	1.1	1.9	1.1
43.0	1.4	1.1	1.4	1.1	1.5	1.1	1.6	1.1	1.6	1.1	1.8	1.1	1.9	1.1	
20 (2.2)	20.0	2.1	1.5	2.2	1.6	2.4	1.5	2.4	1.6	2.5	1.6	2.7	1.6	2.9	1.6
	22.5	2.1	1.5	2.2	1.5	2.3	1.5	2.4	1.6	2.5	1.6	2.6	1.6	2.8	1.6
	25.0	2.1	1.5	2.1	1.5	2.3	1.5	2.4	1.6	2.4	1.6	2.6	1.6	2.8	1.6
	27.5	2.0	1.5	2.1	1.5	2.2	1.5	2.3	1.6	2.4	1.6	2.6	1.6	2.7	1.5
	30.0	2.0	1.4	2.0	1.5	2.2	1.5	2.3	1.6	2.4	1.5	2.5	1.5	2.7	1.5
	32.5	1.9	1.4	2.0	1.5	2.2	1.5	2.2	1.5	2.3	1.5	2.5	1.5	2.6	1.5
	35.0	1.9	1.4	2.0	1.4	2.1	1.4	2.2	1.5	2.3	1.5	2.4	1.5	2.6	1.5
	37.5	1.9	1.4	1.9	1.4	2.1	1.4	2.1	1.5	2.2	1.5	2.4	1.5	2.5	1.5
	40.0	1.8	1.4	1.9	1.4	2.0	1.4	2.1	1.5	2.2	1.5	2.3	1.5	2.5	1.4
43.0	1.8	1.3	1.8	1.4	2.0	1.4	2.1	1.5	2.1	1.5	2.3	1.4	2.4	1.4	
25 (2.8)	20.0	2.7	1.9	2.8	2.0	3.0	1.9	3.1	2.1	3.2	2.0	3.4	2.0	3.7	2.0
	22.5	2.7	1.9	2.8	1.9	3.0	1.9	3.1	2.0	3.2	2.0	3.4	2.0	3.6	2.0
	25.0	2.6	1.8	2.7	1.9	2.9	1.9	3.0	2.0	3.1	2.0	3.3	2.0	3.5	1.9
	27.5	2.6	1.8	2.7	1.9	2.9	1.9	3.0	2.0	3.1	2.0	3.3	1.9	3.5	1.9
	30.0	2.5	1.8	2.6	1.8	2.8	1.8	2.9	1.9	3.0	1.9	3.2	1.9	3.4	1.9
	32.5	2.5	1.8	2.6	1.8	2.7	1.8	2.8	1.9	2.9	1.9	3.1	1.9	3.3	1.9
	35.0	2.4	1.8	2.5	1.8	2.7	1.8	2.8	1.9	2.9	1.9	3.1	1.9	3.3	1.9
	37.5	2.4	1.7	2.5	1.8	2.6	1.8	2.7	1.9	2.8	1.9	3.0	1.9	3.2	1.8
	40.0	2.3	1.7	2.4	1.8	2.6	1.7	2.7	1.9	2.8	1.8	3.0	1.8	3.1	1.8
43.0	2.3	1.7	2.4	1.7	2.5	1.7	2.6	1.8	2.7	1.8	2.9	1.8	3.1	1.8	
32 (3.6)	20.0	3.5	2.6	3.6	2.7	3.9	2.7	4.0	2.9	4.1	2.9	4.4	2.9	4.7	2.8
	22.5	3.4	2.6	3.5	2.7	3.8	2.7	3.9	2.9	4.1	2.9	4.3	2.8	4.6	2.8
	25.0	3.4	2.6	3.5	2.7	3.7	2.7	3.9	2.8	4.0	2.8	4.3	2.8	4.5	2.8
	27.5	3.3	2.6	3.4	2.6	3.7	2.6	3.8	2.8	3.9	2.8	4.2	2.8	4.5	2.7
	30.0	3.2	2.5	3.4	2.6	3.6	2.6	3.7	2.8	3.9	2.8	4.1	2.7	4.4	2.7
	32.5	3.2	2.5	3.3	2.6	3.5	2.6	3.7	2.7	3.8	2.7	4.0	2.7	4.3	2.7
	35.0	3.1	2.5	3.2	2.6	3.5	2.5	3.6	2.7	3.7	2.7	4.0	2.7	4.2	2.6
	37.5	3.1	2.4	3.2	2.5	3.4	2.5	3.5	2.7	3.6	2.7	3.9	2.7	4.1	2.6
	40.0	3.0	2.4	3.1	2.5	3.3	2.5	3.4	2.7	3.6	2.6	3.8	2.6	4.0	2.6
43.0	2.9	2.4	3.0	2.5	3.2	2.5	3.4	2.6	3.5	2.6	3.7	2.6	3.9	2.6	
40 (4.5)	20.0	4.3	3.2	4.5	3.3	4.8	3.3	5.0	3.5	5.2	3.5	5.5	3.5	5.9	3.4
	22.5	4.3	3.2	4.4	3.3	4.7	3.3	4.9	3.5	5.1	3.5	5.4	3.4	5.8	3.4
	25.0	4.2	3.2	4.3	3.3	4.7	3.2	4.8	3.4	5.0	3.4	5.3	3.4	5.7	3.4
	27.5	4.1	3.1	4.3	3.2	4.6	3.2	4.7	3.4	4.9	3.4	5.2	3.4	5.6	3.3
	30.0	4.1	3.1	4.2	3.2	4.5	3.2	4.7	3.4	4.8	3.4	5.1	3.3	5.5	3.3
	32.5	4.0	3.0	4.1	3.1	4.4	3.1	4.6	3.3	4.7	3.3	5.0	3.3	5.4	3.2
	35.0	3.9	3.0	4.0	3.1	4.3	3.1	4.5	3.3	4.6	3.3	4.9	3.3	5.3	3.2
	37.5	3.8	3.0	4.0	3.1	4.2	3.1	4.4	3.3	4.5	3.3	4.8	3.2	5.2	3.2
	40.0	3.8	2.9	3.9	3.0	4.2	3.0	4.3	3.2	4.5	3.2	4.8	3.2	5.1	3.1
43.0	3.7	2.9	3.8	3.0	4.1	3.0	4.2	3.2	4.3	3.2	4.6	3.1	4.9	3.1	
50 (5.6)	20.0	5.4	3.8	5.6	3.9	6.0	3.9	6.2	4.1	6.4	4.1	6.9	4.1	7.3	4.0
	22.5	5.3	3.8	5.5	3.9	5.9	3.9	6.1	4.1	6.3	4.1	6.7	4.0	7.2	4.0
	25.0	5.2	3.7	5.4	3.8	5.8	3.8	6.0	4.0	6.2	4.0	6.6	4.0	7.0	3.9
	27.5	5.1	3.7	5.3	3.8	5.7	3.8	5.9	4.0	6.1	4.0	6.5	3.9	6.9	3.9
	30.0	5.0	3.6	5.2	3.7	5.6	3.7	5.8	4.0	6.0	3.9	6.4	3.9	6.8	3.8
	32.5	5.0	3.6	5.1	3.7	5.5	3.7	5.7	3.9	5.9	3.9	6.3	3.9	6.7	3.8
	35.0	4.9	3.5	5.0	3.6	5.4	3.6	5.6	3.9	5.8	3.8	6.2	3.8	6.5	3.8
	37.5	4.8	3.5	4.9	3.6	5.3	3.6	5.5	3.8	5.7	3.8	6.0	3.8	6.4	3.7
	40.0	4.7	3.5	4.8	3.6	5.2	3.5	5.4	3.8	5.5	3.7	5.9	3.7	6.3	3.7
43.0	4.6	3.4	4.7	3.5	5.1	3.5	5.2	3.7	5.4	3.7	5.8	3.7	6.1	3.6	
63 (7.1)	20.0	6.9	5.2	7.1	5.4	7.6	5.4	7.9	5.8	8.2	5.7	8.7	5.7	9.3	5.6
	22.5	6.7	5.2	7.0	5.4	7.5	5.4	7.8	5.7	8.0	5.7	8.6	5.6	9.1	5.5
	25.0	6.6	5.1	6.9	5.3	7.4	5.3	7.6	5.6	7.9	5.6	8.4	5.6	8.9	5.5
	27.5	6.5	5.1	6.7	5.3	7.2	5.2	7.5	5.6	7.7	5.6	8.3	5.5	8.8	5.4
	30.0	6.4	5.0	6.6	5.2	7.1	5.2	7.3	5.5	7.6	5.5	8.1	5.4	8.6	5.4
	32.5	6.3	5.0	6.5	5.1	7.0	5.1	7.2	5.5	7.5	5.4	7.9	5.4	8.5	5.3
	35.0	6.2	4.9	6.4	5.1	6.8	5.1	7.1	5.4	7.3	5.4	7.8	5.3	8.3	5.3
	37.5	6.1	4.9	6.2	5.0	6.7	5.0	6.9	5.3	7.2	5.3	7.6	5.3	8.1	5.2
	40.0	5.9	4.8	6.1	5.0	6.6	4.9	6.8	5.3	7.0	5.3	7.5	5.2	8.0	5.2
43.0	5.8	4.7	6.0	4.9	6.4	4.9	6.6	5.2	6.9	5.2	7.3	5.2	7.8	5.1	

kcal/h = kW x 860 , BTU/h = kW x 3,412

7. Cooling [Wall mounted]

PKFY-P-VBM-E,VHM-E,VKM-E

CA:Capacity(kW) , SHC:Sensible Heat Capacity(kW)

Model size (Rated kW)	Outdoor air temp. °C D.B.	Indoor air temp.													
		21.5°C D.B. 15°C W.B.		23°C D.B. 16°C W.B.		25°C D.B. 18°C W.B.		27°C D.B. 19°C W.B.		28°C D.B. 20°C W.B.		30°C D.B. 22°C W.B.		32°C D.B. 24°C W.B.	
		CA	SHC	CA	SHC	CA	SHC	CA	SHC	CA	SHC	CA	SHC	CA	SHC
100 (11.2)	20.0	10.8	7.7	11.2	8.0	12.0	7.9	12.5	8.4	12.9	8.4	13.7	8.3	14.6	8.2
	22.5	10.6	7.6	11.0	7.9	11.8	7.8	12.2	8.3	12.6	8.3	13.5	8.2	14.4	8.1
	25.0	10.5	7.5	10.8	7.8	11.6	7.7	12.0	8.2	12.4	8.2	13.3	8.1	14.1	8.0
	27.5	10.3	7.4	10.6	7.7	11.4	7.6	11.8	8.1	12.2	8.1	13.0	8.0	13.8	7.9
	30.0	10.1	7.4	10.4	7.6	11.2	7.5	11.6	8.0	12.0	8.0	12.8	7.9	13.6	7.8
	32.5	9.9	7.3	10.2	7.5	11.0	7.5	11.4	7.9	11.8	7.9	12.5	7.8	13.3	7.7
	35.0	9.7	7.2	10.0	7.4	10.8	7.4	11.2	7.8	11.5	7.8	12.3	7.7	13.1	7.6
	37.5	9.5	7.1	9.8	7.3	10.6	7.3	10.9	7.7	11.3	7.7	12.1	7.6	12.8	7.5
	40.0	9.4	7.0	9.6	7.2	10.4	7.2	10.7	7.6	11.1	7.6	11.8	7.5	12.6	7.4
	43.0	9.2	6.9	9.4	7.1	10.1	7.1	10.5	7.5	10.8	7.5	11.5	7.4	12.3	7.3

kcal/h=kW x 860 , BTU/h = kW x 3,412

7. Cooling [Wall mounted]

7-5. Cooling capacity with PUHY-RP850-900YSJM

PKFY-P-VBM-E,VHM-E,VKM-E

CA:Capacity(kW) , SHC:Sensible Heat Capacity(kW)

Model size (Rated kW)	Outdoor air temp.	Indoor air temp.													
		21.5°C D.B. 15°C W.B.		23°C D.B. 16°C W.B.		25°C D.B. 18°C W.B.		27°C D.B. 19°C W.B.		28°C D.B. 20°C W.B.		30°C D.B. 22°C W.B.		32°C D.B. 24°C W.B.	
		°C D.B.	CA	SHC	CA	SHC	CA	SHC	CA	SHC	CA	SHC	CA	SHC	CA
15 (1.7)	20.0	1.6	1.2	1.7	1.2	1.8	1.2	1.8	1.3	1.9	1.2	2.0	1.2	2.1	1.2
	22.5	1.6	1.2	1.6	1.2	1.8	1.2	1.8	1.2	1.9	1.2	2.0	1.2	2.1	1.2
	25.0	1.6	1.1	1.6	1.2	1.7	1.2	1.8	1.2	1.8	1.2	2.0	1.2	2.1	1.2
	27.5	1.6	1.1	1.6	1.2	1.7	1.2	1.8	1.2	1.8	1.2	2.0	1.2	2.1	1.2
	30.0	1.5	1.1	1.6	1.2	1.7	1.1	1.8	1.2	1.8	1.2	1.9	1.2	2.1	1.2
	32.5	1.5	1.1	1.6	1.1	1.7	1.1	1.7	1.2	1.8	1.2	1.9	1.2	2.0	1.2
	35.0	1.5	1.1	1.5	1.1	1.7	1.1	1.7	1.2	1.8	1.2	1.9	1.2	2.0	1.2
	37.5	1.5	1.1	1.5	1.1	1.6	1.1	1.7	1.2	1.8	1.2	1.9	1.2	2.0	1.2
	40.0	1.5	1.1	1.5	1.1	1.6	1.1	1.7	1.2	1.7	1.2	1.9	1.2	2.0	1.2
43.0	1.5	1.1	1.5	1.1	1.6	1.1	1.7	1.2	1.7	1.2	1.8	1.2	2.0	1.2	
20 (2.2)	20.0	2.1	1.5	2.1	1.5	2.3	1.5	2.4	1.6	2.4	1.6	2.6	1.6	2.8	1.5
	22.5	2.1	1.5	2.1	1.5	2.3	1.5	2.3	1.6	2.4	1.6	2.6	1.6	2.7	1.5
	25.0	2.0	1.5	2.1	1.5	2.2	1.5	2.3	1.6	2.4	1.6	2.5	1.6	2.7	1.5
	27.5	2.0	1.4	2.1	1.5	2.2	1.5	2.3	1.6	2.4	1.6	2.5	1.5	2.7	1.5
	30.0	2.0	1.4	2.0	1.5	2.2	1.5	2.3	1.6	2.3	1.5	2.5	1.5	2.7	1.5
	32.5	2.0	1.4	2.0	1.5	2.2	1.5	2.2	1.5	2.3	1.5	2.5	1.5	2.6	1.5
	35.0	2.0	1.4	2.0	1.4	2.1	1.4	2.2	1.5	2.3	1.5	2.5	1.5	2.6	1.5
	37.5	1.9	1.4	2.0	1.4	2.1	1.4	2.2	1.5	2.3	1.5	2.4	1.5	2.6	1.5
	40.0	1.9	1.4	1.9	1.4	2.1	1.4	2.2	1.5	2.2	1.5	2.4	1.5	2.6	1.5
43.0	1.9	1.4	1.9	1.4	2.1	1.4	2.1	1.5	2.2	1.5	2.4	1.5	2.5	1.5	
25 (2.8)	20.0	2.6	1.9	2.7	1.9	2.9	1.9	3.0	2.0	3.1	2.0	3.3	2.0	3.5	1.9
	22.5	2.6	1.9	2.7	1.9	2.9	1.9	3.0	2.0	3.1	2.0	3.3	2.0	3.5	1.9
	25.0	2.6	1.8	2.7	1.9	2.9	1.9	2.9	2.0	3.0	2.0	3.2	1.9	3.5	1.9
	27.5	2.6	1.8	2.6	1.9	2.8	1.9	2.9	2.0	3.0	2.0	3.2	1.9	3.4	1.9
	30.0	2.5	1.8	2.6	1.8	2.8	1.8	2.9	1.9	3.0	1.9	3.2	1.9	3.4	1.9
	32.5	2.5	1.8	2.6	1.8	2.8	1.8	2.9	1.9	3.0	1.9	3.2	1.9	3.4	1.9
	35.0	2.5	1.8	2.5	1.8	2.7	1.8	2.8	1.9	2.9	1.9	3.1	1.9	3.3	1.9
	37.5	2.5	1.8	2.5	1.8	2.7	1.8	2.8	1.9	2.9	1.9	3.1	1.9	3.3	1.9
	40.0	2.4	1.8	2.5	1.8	2.7	1.8	2.8	1.9	2.9	1.9	3.1	1.9	3.3	1.9
43.0	2.4	1.7	2.4	1.8	2.6	1.8	2.7	1.9	2.8	1.9	3.0	1.9	3.2	1.8	
32 (3.6)	20.0	3.4	2.6	3.5	2.7	3.7	2.7	3.9	2.8	4.0	2.8	4.3	2.8	4.5	2.8
	22.5	3.4	2.6	3.5	2.7	3.7	2.7	3.8	2.8	4.0	2.8	4.2	2.8	4.5	2.7
	25.0	3.3	2.6	3.4	2.6	3.7	2.6	3.8	2.8	3.9	2.8	4.2	2.8	4.4	2.7
	27.5	3.3	2.6	3.4	2.6	3.6	2.6	3.8	2.8	3.9	2.8	4.1	2.7	4.4	2.7
	30.0	3.3	2.5	3.3	2.6	3.6	2.6	3.7	2.8	3.8	2.8	4.1	2.7	4.4	2.7
	32.5	3.2	2.5	3.3	2.6	3.5	2.6	3.7	2.8	3.8	2.7	4.1	2.7	4.3	2.7
	35.0	3.2	2.5	3.3	2.6	3.5	2.6	3.6	2.7	3.8	2.7	4.0	2.7	4.3	2.7
	37.5	3.2	2.5	3.2	2.6	3.5	2.5	3.6	2.7	3.7	2.7	4.0	2.7	4.2	2.7
	40.0	3.1	2.5	3.2	2.5	3.4	2.5	3.5	2.7	3.7	2.7	3.9	2.7	4.2	2.6
43.0	3.1	2.5	3.1	2.5	3.4	2.5	3.5	2.7	3.6	2.7	3.9	2.7	4.2	2.6	
40 (4.5)	20.0	4.3	3.2	4.4	3.3	4.7	3.3	4.8	3.5	5.0	3.4	5.3	3.4	5.7	3.4
	22.5	4.2	3.2	4.3	3.2	4.6	3.2	4.8	3.4	4.9	3.4	5.3	3.4	5.6	3.3
	25.0	4.2	3.1	4.3	3.2	4.6	3.2	4.7	3.4	4.9	3.4	5.2	3.4	5.6	3.3
	27.5	4.1	3.1	4.2	3.2	4.5	3.2	4.7	3.4	4.8	3.4	5.2	3.3	5.5	3.3
	30.0	4.1	3.1	4.2	3.2	4.5	3.2	4.6	3.4	4.8	3.4	5.1	3.3	5.5	3.3
	32.5	4.0	3.1	4.1	3.2	4.4	3.1	4.6	3.3	4.7	3.3	5.1	3.3	5.4	3.3
	35.0	4.0	3.1	4.1	3.1	4.4	3.1	4.5	3.3	4.7	3.3	5.0	3.3	5.4	3.2
	37.5	4.0	3.0	4.0	3.1	4.3	3.1	4.5	3.3	4.6	3.3	5.0	3.3	5.3	3.2
	40.0	3.9	3.0	4.0	3.1	4.3	3.1	4.4	3.3	4.6	3.3	4.9	3.2	5.3	3.2
43.0	3.9	3.0	3.9	3.1	4.2	3.1	4.4	3.3	4.5	3.2	4.9	3.2	5.2	3.2	
50 (5.6)	20.0	5.3	3.8	5.5	3.9	5.8	3.8	6.0	4.1	6.2	4.0	6.6	4.0	7.0	3.9
	22.5	5.2	3.7	5.4	3.8	5.8	3.8	6.0	4.0	6.2	4.0	6.6	4.0	7.0	3.9
	25.0	5.2	3.7	5.3	3.8	5.7	3.8	5.9	4.0	6.1	4.0	6.5	3.9	6.9	3.9
	27.5	5.1	3.7	5.3	3.8	5.6	3.8	5.8	4.0	6.0	4.0	6.4	3.9	6.9	3.9
	30.0	5.1	3.7	5.2	3.7	5.6	3.7	5.8	3.9	6.0	3.9	6.4	3.9	6.8	3.8
	32.5	5.0	3.6	5.1	3.7	5.5	3.7	5.7	3.9	5.9	3.9	6.3	3.9	6.7	3.8
	35.0	5.0	3.6	5.1	3.7	5.4	3.7	5.6	3.9	5.8	3.9	6.2	3.8	6.7	3.8
	37.5	4.9	3.6	5.0	3.6	5.4	3.6	5.6	3.9	5.8	3.8	6.2	3.8	6.6	3.8
	40.0	4.9	3.5	4.9	3.6	5.3	3.6	5.5	3.8	5.7	3.8	6.1	3.8	6.5	3.8
43.0	4.8	3.5	4.9	3.6	5.2	3.6	5.4	3.8	5.6	3.8	6.0	3.8	6.5	3.7	
63 (7.1)	20.0	6.7	5.2	6.9	5.3	7.4	5.3	7.6	5.6	7.9	5.6	8.4	5.6	8.9	5.5
	22.5	6.6	5.1	6.8	5.3	7.3	5.3	7.6	5.6	7.8	5.6	8.3	5.5	8.8	5.5
	25.0	6.6	5.1	6.8	5.3	7.2	5.2	7.5	5.6	7.7	5.6	8.2	5.5	8.8	5.4
	27.5	6.5	5.1	6.7	5.2	7.2	5.2	7.4	5.5	7.6	5.5	8.2	5.5	8.7	5.4
	30.0	6.4	5.0	6.6	5.2	7.1	5.2	7.3	5.5	7.6	5.5	8.1	5.4	8.6	5.4
	32.5	6.4	5.0	6.5	5.1	7.0	5.1	7.2	5.5	7.5	5.5	8.0	5.4	8.5	5.3
	35.0	6.3	5.0	6.4	5.1	6.9	5.1	7.1	5.4	7.4	5.4	7.9	5.4	8.5	5.3
	37.5	6.2	5.0	6.3	5.1	6.8	5.1	7.1	5.4	7.3	5.4	7.8	5.3	8.4	5.3
	40.0	6.2	4.9	6.3	5.0	6.7	5.0	7.0	5.4	7.2	5.4	7.8	5.3	8.3	5.3
43.0	6.1	4.9	6.2	5.0	6.7	5.0	6.9	5.3	7.1	5.3	7.7	5.3	8.2	5.2	

kcal/h=kW x 860 , BTU/h = kW x 3,412

7. Cooling [Wall mounted]

PKFY-P-VBM-E,VHM-E,VKM-E

CA:Capacity(kW) , SHC:Sensible Heat Capacity(kW)

Model size (Rated kW)	Outdoor air temp. °C D.B.	Indoor air temp.													
		21.5°C D.B. 15°C W.B.		23°C D.B. 16°C W.B.		25°C D.B. 18°C W.B.		27°C D.B. 19°C W.B.		28°C D.B. 20°C W.B.		30°C D.B. 22°C W.B.		32°C D.B. 24°C W.B.	
		CA	SHC	CA	SHC	CA	SHC	CA	SHC	CA	SHC	CA	SHC	CA	SHC
100 (11.2)	20.0	10.6	7.6	10.9	7.8	11.7	7.8	12.0	8.2	12.4	8.2	13.2	8.1	14.1	8.0
	22.5	10.5	7.5	10.8	7.7	11.5	7.7	11.9	8.1	12.3	8.1	13.1	8.0	13.9	7.9
	25.0	10.4	7.5	10.6	7.7	11.4	7.6	11.8	8.1	12.2	8.0	13.0	8.0	13.8	7.9
	27.5	10.3	7.4	10.5	7.6	11.3	7.6	11.7	8.0	12.1	8.0	12.9	7.9	13.7	7.8
	30.0	10.2	7.4	10.4	7.5	11.2	7.5	11.5	8.0	11.9	7.9	12.7	7.9	13.6	7.8
	32.5	10.1	7.3	10.3	7.5	11.0	7.5	11.4	7.9	11.8	7.9	12.6	7.8	13.5	7.7
	35.0	9.9	7.3	10.1	7.4	10.9	7.4	11.2	7.8	11.7	7.8	12.5	7.8	13.3	7.7
	37.5	9.8	7.2	10.0	7.4	10.8	7.4	11.2	7.8	11.6	7.8	12.4	7.7	13.2	7.6
	40.0	9.7	7.2	9.9	7.3	10.6	7.3	11.0	7.7	11.4	7.7	12.2	7.7	13.1	7.6
	43.0	9.6	7.1	9.7	7.2	10.5	7.2	10.9	7.7	11.3	7.7	12.1	7.6	12.9	7.5

kcal/h=kW x 860 , BTU/h = kW x 3,412

8. Cooling [Floor standing (Exposed 2-way/Exposed/Concealed type)]

8-1. Cooling capacity with PUHY,PURY-RP200-250YJM

PFFY-P-VKM-E

CA:Capacity(kW) , SHC:Sensible Heat Capacity(kW)

Model size (Rated kW)	Outdoor air temp. °C D.B.	Indoor air temp.													
		21.5°C D.B. 15°C W.B.		23°C D.B. 16°C W.B.		25°C D.B. 18°C W.B.		27°C D.B. 19°C W.B.		28°C D.B. 20°C W.B.		30°C D.B. 22°C W.B.		32°C D.B. 24°C W.B.	
		CA	SHC	CA	SHC	CA	SHC	CA	SHC	CA	SHC	CA	SHC	CA	SHC
20 (2.2)	20.0	2.1	1.7	2.2	1.7	2.3	1.7	2.4	1.8	2.5	1.8	2.6	1.8	2.8	1.8
	22.5	2.1	1.7	2.2	1.7	2.3	1.7	2.4	1.8	2.5	1.8	2.6	1.8	2.8	1.8
	25.0	2.1	1.7	2.2	1.7	2.3	1.7	2.4	1.8	2.4	1.8	2.6	1.8	2.7	1.8
	27.5	2.1	1.7	2.1	1.7	2.3	1.7	2.3	1.8	2.4	1.8	2.5	1.8	2.7	1.7
	30.0	2.0	1.7	2.1	1.7	2.2	1.7	2.3	1.8	2.3	1.8	2.5	1.8	2.6	1.7
	32.5	2.0	1.6	2.1	1.7	2.2	1.7	2.2	1.8	2.3	1.8	2.4	1.7	2.6	1.7
	35.0	2.0	1.6	2.0	1.7	2.1	1.7	2.2	1.8	2.3	1.7	2.4	1.7	2.5	1.7
	37.5	1.9	1.6	2.0	1.7	2.1	1.6	2.2	1.7	2.2	1.7	2.3	1.7	2.5	1.7
	40.0	1.9	1.6	2.0	1.6	2.1	1.6	2.1	1.7	2.2	1.7	2.3	1.7	2.4	1.7
43.0	1.8	1.6	1.9	1.6	2.0	1.6	2.1	1.7	2.1	1.7	2.2	1.7	2.3	1.6	
25 (2.8)	20.0	2.7	2.0	2.8	2.1	2.9	2.0	3.0	2.2	3.1	2.1	3.3	2.1	3.5	2.1
	22.5	2.7	2.0	2.8	2.1	2.9	2.0	3.0	2.2	3.1	2.1	3.3	2.1	3.5	2.1
	25.0	2.7	2.0	2.8	2.1	2.9	2.0	3.0	2.2	3.1	2.1	3.3	2.1	3.5	2.1
	27.5	2.7	2.0	2.7	2.0	2.9	2.0	3.0	2.1	3.0	2.1	3.2	2.1	3.4	2.1
	30.0	2.6	2.0	2.7	2.0	2.8	2.0	2.9	2.1	3.0	2.1	3.2	2.1	3.3	2.0
	32.5	2.6	1.9	2.6	2.0	2.8	2.0	2.9	2.1	2.9	2.1	3.1	2.0	3.3	2.0
	35.0	2.5	1.9	2.6	2.0	2.7	1.9	2.8	2.1	2.9	2.0	3.0	2.0	3.2	2.0
	37.5	2.5	1.9	2.5	1.9	2.7	1.9	2.8	2.0	2.8	2.0	3.0	2.0	3.1	2.0
	40.0	2.4	1.9	2.5	1.9	2.6	1.9	2.7	2.0	2.8	2.0	2.9	2.0	3.1	1.9
43.0	2.4	1.8	2.4	1.9	2.6	1.9	2.6	2.0	2.7	2.0	2.8	1.9	3.0	1.9	
32 (3.6)	20.0	3.4	2.4	3.5	2.5	3.8	2.5	3.9	2.6	4.0	2.6	4.3	2.6	4.6	2.5
	22.5	3.4	2.4	3.5	2.5	3.8	2.5	3.9	2.6	4.0	2.6	4.3	2.6	4.6	2.5
	25.0	3.4	2.4	3.5	2.5	3.8	2.5	3.9	2.6	4.0	2.6	4.2	2.5	4.5	2.5
	27.5	3.4	2.4	3.5	2.5	3.7	2.4	3.8	2.6	3.9	2.5	4.1	2.5	4.4	2.5
	30.0	3.3	2.4	3.4	2.4	3.6	2.4	3.7	2.5	3.8	2.5	4.1	2.5	4.3	2.4
	32.5	3.3	2.4	3.4	2.4	3.6	2.4	3.7	2.5	3.8	2.5	4.0	2.4	4.2	2.4
	35.0	3.2	2.3	3.3	2.4	3.5	2.4	3.6	2.5	3.7	2.5	3.9	2.4	4.1	2.4
	37.5	3.2	2.3	3.3	2.3	3.4	2.3	3.5	2.4	3.6	2.4	3.8	2.4	4.0	2.3
	40.0	3.1	2.3	3.2	2.3	3.4	2.3	3.5	2.4	3.6	2.4	3.7	2.3	3.9	2.3
43.0	3.0	2.2	3.1	2.3	3.3	2.3	3.4	2.4	3.5	2.4	3.6	2.3	3.8	2.3	
40 (4.5)	20.0	4.3	3.0	4.4	3.1	4.7	3.1	4.9	3.2	5.0	3.2	5.3	3.2	5.7	3.1
	22.5	4.3	3.0	4.4	3.1	4.7	3.1	4.9	3.2	5.0	3.2	5.3	3.2	5.7	3.1
	25.0	4.3	3.0	4.4	3.1	4.7	3.1	4.9	3.2	5.0	3.2	5.3	3.1	5.6	3.1
	27.5	4.3	3.0	4.4	3.1	4.6	3.0	4.8	3.2	4.9	3.1	5.2	3.1	5.5	3.0
	30.0	4.2	2.9	4.3	3.0	4.6	3.0	4.7	3.1	4.8	3.1	5.1	3.0	5.4	3.0
	32.5	4.1	2.9	4.2	3.0	4.5	2.9	4.6	3.1	4.7	3.1	5.0	3.0	5.3	3.0
	35.0	4.0	2.9	4.1	2.9	4.4	2.9	4.5	3.0	4.6	3.0	4.9	3.0	5.2	2.9
	37.5	4.0	2.8	4.1	2.9	4.3	2.9	4.4	3.0	4.5	3.0	4.8	2.9	5.0	2.9
	40.0	3.9	2.8	4.0	2.9	4.2	2.8	4.3	3.0	4.4	2.9	4.7	2.9	4.9	2.8
43.0	3.8	2.7	3.9	2.8	4.1	2.8	4.2	2.9	4.3	2.9	4.5	2.8	4.8	2.8	

kcal/h=kW x 860 , BTU/h = kW x 3,412

8. Cooling [Floor standing (Exposed 2-way/Exposed/Concealed type)]

PFFY-P-VLEM-E,VLRM-E

CA:Capacity(kW) , SHC:Sensible Heat Capacity(kW)

Model size (Rated kW)	Outdoor air temp. °C D.B.	Indoor air temp.													
		21.5°C D.B. 15°C W.B.		23°C D.B. 16°C W.B.		25°C D.B. 18°C W.B.		27°C D.B. 19°C W.B.		28°C D.B. 20°C W.B.		30°C D.B. 22°C W.B.		32°C D.B. 24°C W.B.	
		CA	SHC	CA	SHC	CA	SHC	CA	SHC	CA	SHC	CA	SHC	CA	SHC
20 (2.2)	20.0	2.1	1.7	2.2	1.7	2.3	1.7	2.4	1.8	2.5	1.8	2.6	1.8	2.8	1.8
	22.5	2.1	1.7	2.2	1.7	2.3	1.7	2.4	1.8	2.5	1.8	2.6	1.8	2.8	1.8
	25.0	2.1	1.7	2.2	1.7	2.3	1.7	2.4	1.8	2.4	1.8	2.6	1.8	2.7	1.8
	27.5	2.1	1.7	2.1	1.7	2.3	1.7	2.3	1.8	2.4	1.8	2.5	1.8	2.7	1.7
	30.0	2.0	1.6	2.1	1.7	2.2	1.7	2.3	1.8	2.3	1.8	2.5	1.7	2.6	1.7
	32.5	2.0	1.6	2.1	1.7	2.2	1.7	2.2	1.8	2.3	1.8	2.4	1.7	2.6	1.7
	35.0	2.0	1.6	2.0	1.7	2.1	1.6	2.2	1.7	2.3	1.7	2.4	1.7	2.5	1.7
	37.5	1.9	1.6	2.0	1.6	2.1	1.6	2.2	1.7	2.2	1.7	2.3	1.7	2.5	1.7
	40.0	1.9	1.6	2.0	1.6	2.1	1.6	2.1	1.7	2.2	1.7	2.3	1.7	2.4	1.6
43.0	1.8	1.5	1.9	1.6	2.0	1.6	2.1	1.7	2.1	1.7	2.2	1.6	2.3	1.6	
25 (2.8)	20.0	2.7	1.9	2.8	2.0	2.9	2.0	3.0	2.1	3.1	2.1	3.3	2.1	3.5	2.0
	22.5	2.7	1.9	2.8	2.0	2.9	2.0	3.0	2.1	3.1	2.1	3.3	2.1	3.5	2.0
	25.0	2.7	1.9	2.8	2.0	2.9	2.0	3.0	2.1	3.1	2.1	3.3	2.0	3.5	2.0
	27.5	2.7	1.9	2.7	2.0	2.9	2.0	3.0	2.1	3.0	2.1	3.2	2.0	3.4	2.0
	30.0	2.6	1.9	2.7	2.0	2.8	1.9	2.9	2.0	3.0	2.0	3.2	2.0	3.3	2.0
	32.5	2.6	1.9	2.6	1.9	2.8	1.9	2.9	2.0	2.9	2.0	3.1	2.0	3.3	1.9
	35.0	2.5	1.9	2.6	1.9	2.7	1.9	2.8	2.0	2.9	2.0	3.0	1.9	3.2	1.9
	37.5	2.5	1.8	2.5	1.9	2.7	1.9	2.8	2.0	2.8	2.0	3.0	1.9	3.1	1.9
	40.0	2.4	1.8	2.5	1.9	2.6	1.8	2.7	2.0	2.8	1.9	2.9	1.9	3.1	1.9
43.0	2.4	1.8	2.4	1.8	2.6	1.8	2.6	1.9	2.7	1.9	2.8	1.9	3.0	1.8	
32 (3.6)	20.0	3.4	2.5	3.5	2.6	3.8	2.5	3.9	2.7	4.0	2.7	4.3	2.6	4.6	2.6
	22.5	3.4	2.5	3.5	2.6	3.8	2.5	3.9	2.7	4.0	2.7	4.3	2.6	4.6	2.6
	25.0	3.4	2.5	3.5	2.6	3.8	2.5	3.9	2.7	4.0	2.6	4.2	2.6	4.5	2.6
	27.5	3.4	2.5	3.5	2.5	3.7	2.5	3.8	2.6	3.9	2.6	4.1	2.6	4.4	2.5
	30.0	3.3	2.4	3.4	2.5	3.6	2.5	3.7	2.6	3.8	2.6	4.1	2.5	4.3	2.5
	32.5	3.3	2.4	3.4	2.5	3.6	2.4	3.7	2.6	3.8	2.6	4.0	2.5	4.2	2.5
	35.0	3.2	2.4	3.3	2.4	3.5	2.4	3.6	2.5	3.7	2.5	3.9	2.5	4.1	2.4
	37.5	3.2	2.3	3.3	2.4	3.4	2.4	3.5	2.5	3.6	2.5	3.8	2.5	4.0	2.4
	40.0	3.1	2.3	3.2	2.4	3.4	2.4	3.5	2.5	3.6	2.5	3.7	2.4	3.9	2.4
43.0	3.0	2.3	3.1	2.3	3.3	2.3	3.4	2.5	3.5	2.4	3.6	2.4	3.8	2.3	
40 (4.5)	20.0	4.3	3.1	4.4	3.2	4.7	3.2	4.9	3.4	5.0	3.3	5.3	3.3	5.7	3.3
	22.5	4.3	3.1	4.4	3.2	4.7	3.2	4.9	3.4	5.0	3.3	5.3	3.3	5.7	3.3
	25.0	4.3	3.1	4.4	3.2	4.7	3.2	4.9	3.4	5.0	3.3	5.3	3.3	5.6	3.2
	27.5	4.3	3.1	4.4	3.2	4.6	3.2	4.8	3.3	4.9	3.3	5.2	3.2	5.5	3.2
	30.0	4.2	3.1	4.3	3.1	4.6	3.1	4.7	3.3	4.8	3.3	5.1	3.2	5.4	3.2
	32.5	4.1	3.0	4.2	3.1	4.5	3.1	4.6	3.2	4.7	3.2	5.0	3.2	5.3	3.1
	35.0	4.0	3.0	4.1	3.1	4.4	3.0	4.5	3.2	4.6	3.2	4.9	3.1	5.2	3.1
	37.5	4.0	3.0	4.1	3.0	4.3	3.0	4.4	3.2	4.5	3.1	4.8	3.1	5.0	3.0
	40.0	3.9	2.9	4.0	3.0	4.2	3.0	4.3	3.1	4.4	3.1	4.7	3.0	4.9	3.0
43.0	3.8	2.9	3.9	2.9	4.1	2.9	4.2	3.1	4.3	3.1	4.5	3.0	4.8	2.9	
50 (5.6)	20.0	5.3	3.9	5.5	4.1	5.9	4.0	6.1	4.3	6.2	4.2	6.6	4.2	7.1	4.1
	22.5	5.3	3.9	5.5	4.1	5.9	4.0	6.1	4.3	6.2	4.2	6.6	4.2	7.1	4.1
	25.0	5.3	3.9	5.5	4.1	5.9	4.0	6.0	4.2	6.2	4.2	6.6	4.2	7.0	4.1
	27.5	5.3	3.9	5.5	4.0	5.8	4.0	5.9	4.2	6.1	4.2	6.4	4.1	6.8	4.0
	30.0	5.2	3.9	5.4	4.0	5.7	3.9	5.8	4.2	6.0	4.1	6.3	4.1	6.7	4.0
	32.5	5.1	3.8	5.3	3.9	5.6	3.9	5.7	4.1	5.9	4.1	6.2	4.0	6.6	3.9
	35.0	5.0	3.8	5.2	3.9	5.5	3.8	5.6	4.1	5.8	4.0	6.1	4.0	6.4	3.9
	37.5	4.9	3.7	5.1	3.8	5.4	3.8	5.5	4.0	5.6	4.0	5.9	3.9	6.3	3.8
	40.0	4.8	3.7	5.0	3.8	5.3	3.7	5.4	4.0	5.5	3.9	5.8	3.9	6.1	3.8
43.0	4.7	3.6	4.8	3.7	5.1	3.7	5.3	3.9	5.4	3.9	5.6	3.8	6.0	3.7	
63 (7.1)	20.0	6.7	4.9	7.0	5.0	7.5	5.0	7.7	5.3	7.9	5.2	8.4	5.2	9.0	5.1
	22.5	6.7	4.9	7.0	5.0	7.5	5.0	7.7	5.3	7.9	5.2	8.4	5.2	9.0	5.1
	25.0	6.7	4.9	7.0	5.0	7.5	5.0	7.7	5.2	7.9	5.2	8.3	5.1	8.8	5.0
	27.5	6.7	4.9	6.9	5.0	7.3	4.9	7.5	5.2	7.7	5.1	8.1	5.1	8.7	5.0
	30.0	6.6	4.8	6.8	4.9	7.2	4.9	7.4	5.1	7.6	5.1	8.0	5.0	8.5	4.9
	32.5	6.5	4.7	6.7	4.9	7.1	4.8	7.2	5.1	7.4	5.0	7.8	4.9	8.3	4.9
	35.0	6.4	4.7	6.5	4.8	6.9	4.7	7.1	5.0	7.3	5.0	7.7	4.9	8.1	4.8
	37.5	6.2	4.6	6.4	4.7	6.8	4.7	7.0	4.9	7.2	4.9	7.5	4.8	8.0	4.7
	40.0	6.1	4.5	6.3	4.7	6.7	4.6	6.8	4.9	7.0	4.8	7.4	4.7	7.8	4.7
43.0	6.0	4.5	6.1	4.6	6.5	4.5	6.7	4.8	6.9	4.8	7.2	4.7	7.6	4.6	

kcal/h=kW x 860 , BTU/h = kW x 3,412

8. Cooling [Floor standing (Exposed 2-way/Exposed/Concealed type)]

PFFY-P-VLRMM-E

CA:Capacity(kW) , SHC:Sensible Heat Capacity(kW)

Model size (Rated kW)	Outdoor air temp. °C D.B.	Indoor air temp.													
		21.5°C D.B. 15°C W.B.		23°C D.B. 16°C W.B.		25°C D.B. 18°C W.B.		27°C D.B. 19°C W.B.		28°C D.B. 20°C W.B.		30°C D.B. 22°C W.B.		32°C D.B. 24°C W.B.	
		CA	SHC	CA	SHC	CA	SHC	CA	SHC	CA	SHC	CA	SHC	CA	SHC
20 (2.2)	20.0	2.1	1.7	2.2	1.7	2.3	1.7	2.4	1.8	2.5	1.8	2.6	1.8	2.8	1.8
	22.5	2.1	1.7	2.2	1.7	2.3	1.7	2.4	1.8	2.5	1.8	2.6	1.8	2.8	1.8
	25.0	2.1	1.7	2.2	1.7	2.3	1.7	2.4	1.8	2.4	1.8	2.6	1.8	2.7	1.8
	27.5	2.1	1.7	2.1	1.7	2.3	1.7	2.3	1.8	2.4	1.8	2.5	1.8	2.7	1.7
	30.0	2.0	1.6	2.1	1.7	2.2	1.7	2.3	1.8	2.3	1.8	2.5	1.7	2.6	1.7
	32.5	2.0	1.6	2.1	1.7	2.2	1.7	2.2	1.8	2.3	1.8	2.4	1.7	2.6	1.7
	35.0	2.0	1.6	2.0	1.7	2.1	1.6	2.2	1.7	2.3	1.7	2.4	1.7	2.5	1.7
	37.5	1.9	1.6	2.0	1.6	2.1	1.6	2.2	1.7	2.2	1.7	2.3	1.7	2.5	1.7
	40.0	1.9	1.6	2.0	1.6	2.1	1.6	2.1	1.7	2.2	1.7	2.3	1.7	2.4	1.6
43.0	1.8	1.5	1.9	1.6	2.0	1.6	2.1	1.7	2.1	1.7	2.2	1.6	2.3	1.6	
25 (2.8)	20.0	2.7	1.9	2.8	2.0	2.9	2.0	3.0	2.1	3.1	2.1	3.3	2.1	3.5	2.0
	22.5	2.7	1.9	2.8	2.0	2.9	2.0	3.0	2.1	3.1	2.1	3.3	2.1	3.5	2.0
	25.0	2.7	1.9	2.8	2.0	2.9	2.0	3.0	2.1	3.1	2.1	3.3	2.0	3.5	2.0
	27.5	2.7	1.9	2.7	2.0	2.9	2.0	3.0	2.1	3.0	2.1	3.2	2.0	3.4	2.0
	30.0	2.6	1.9	2.7	2.0	2.8	1.9	2.9	2.0	3.0	2.0	3.2	2.0	3.3	2.0
	32.5	2.6	1.9	2.6	1.9	2.8	1.9	2.9	2.0	2.9	2.0	3.1	2.0	3.3	1.9
	35.0	2.5	1.9	2.6	1.9	2.7	1.9	2.8	2.0	2.9	2.0	3.0	1.9	3.2	1.9
	37.5	2.5	1.8	2.5	1.9	2.7	1.9	2.8	2.0	2.8	2.0	3.0	1.9	3.1	1.9
	40.0	2.4	1.8	2.5	1.9	2.6	1.8	2.7	2.0	2.8	1.9	2.9	1.9	3.1	1.9
43.0	2.4	1.8	2.4	1.8	2.6	1.8	2.6	1.9	2.7	1.9	2.8	1.9	3.0	1.8	
32 (3.6)	20.0	3.4	2.5	3.5	2.6	3.8	2.5	3.9	2.7	4.0	2.7	4.3	2.6	4.6	2.6
	22.5	3.4	2.5	3.5	2.6	3.8	2.5	3.9	2.7	4.0	2.7	4.3	2.6	4.6	2.6
	25.0	3.4	2.5	3.5	2.6	3.8	2.5	3.9	2.7	4.0	2.6	4.2	2.6	4.5	2.6
	27.5	3.4	2.5	3.5	2.5	3.7	2.5	3.8	2.6	3.9	2.6	4.1	2.6	4.4	2.5
	30.0	3.3	2.4	3.4	2.5	3.6	2.5	3.7	2.6	3.8	2.6	4.1	2.5	4.3	2.5
	32.5	3.3	2.4	3.4	2.5	3.6	2.4	3.7	2.6	3.8	2.6	4.0	2.5	4.2	2.5
	35.0	3.2	2.4	3.3	2.4	3.5	2.4	3.6	2.5	3.7	2.5	3.9	2.5	4.1	2.4
	37.5	3.2	2.3	3.3	2.4	3.4	2.4	3.5	2.5	3.6	2.5	3.8	2.5	4.0	2.4
	40.0	3.1	2.3	3.2	2.4	3.4	2.4	3.5	2.5	3.6	2.5	3.7	2.4	3.9	2.4
43.0	3.0	2.3	3.1	2.3	3.3	2.3	3.4	2.5	3.5	2.4	3.6	2.4	3.8	2.3	
40 (4.5)	20.0	4.3	3.1	4.4	3.2	4.7	3.2	4.9	3.4	5.0	3.3	5.3	3.3	5.7	3.3
	22.5	4.3	3.1	4.4	3.2	4.7	3.2	4.9	3.4	5.0	3.3	5.3	3.3	5.7	3.3
	25.0	4.3	3.1	4.4	3.2	4.7	3.2	4.9	3.4	5.0	3.3	5.3	3.3	5.6	3.2
	27.5	4.3	3.1	4.4	3.2	4.6	3.2	4.8	3.3	4.9	3.3	5.2	3.2	5.5	3.2
	30.0	4.2	3.1	4.3	3.1	4.6	3.1	4.7	3.3	4.8	3.3	5.1	3.2	5.4	3.2
	32.5	4.1	3.0	4.2	3.1	4.5	3.1	4.6	3.2	4.7	3.2	5.0	3.2	5.3	3.1
	35.0	4.0	3.0	4.1	3.1	4.4	3.0	4.5	3.2	4.6	3.2	4.9	3.1	5.2	3.1
	37.5	4.0	3.0	4.1	3.0	4.3	3.0	4.4	3.2	4.5	3.1	4.8	3.1	5.0	3.0
	40.0	3.9	2.9	4.0	3.0	4.2	3.0	4.3	3.1	4.4	3.1	4.7	3.0	4.9	3.0
43.0	3.8	2.9	3.9	2.9	4.1	2.9	4.2	3.1	4.3	3.1	4.5	3.0	4.8	2.9	
50 (5.6)	20.0	5.3	3.9	5.5	4.1	5.9	4.0	6.1	4.3	6.2	4.2	6.6	4.2	7.1	4.1
	22.5	5.3	3.9	5.5	4.1	5.9	4.0	6.1	4.3	6.2	4.2	6.6	4.2	7.1	4.1
	25.0	5.3	3.9	5.5	4.1	5.9	4.0	6.0	4.2	6.2	4.2	6.6	4.2	7.0	4.1
	27.5	5.3	3.9	5.5	4.0	5.8	4.0	5.9	4.2	6.1	4.2	6.4	4.1	6.8	4.0
	30.0	5.2	3.9	5.4	4.0	5.7	3.9	5.8	4.2	6.0	4.1	6.3	4.1	6.7	4.0
	32.5	5.1	3.8	5.3	3.9	5.6	3.9	5.7	4.1	5.9	4.1	6.2	4.0	6.6	3.9
	35.0	5.0	3.8	5.2	3.9	5.5	3.8	5.6	4.1	5.8	4.0	6.1	4.0	6.4	3.9
	37.5	4.9	3.7	5.1	3.8	5.4	3.8	5.5	4.0	5.6	4.0	5.9	3.9	6.3	3.8
	40.0	4.8	3.7	5.0	3.8	5.3	3.7	5.4	4.0	5.5	3.9	5.8	3.9	6.1	3.8
43.0	4.7	3.6	4.8	3.7	5.1	3.7	5.3	3.9	5.4	3.9	5.6	3.8	6.0	3.7	
63 (7.1)	20.0	6.7	4.9	7.0	5.0	7.5	5.0	7.7	5.3	7.9	5.2	8.4	5.2	9.0	5.1
	22.5	6.7	4.9	7.0	5.0	7.5	5.0	7.7	5.3	7.9	5.2	8.4	5.2	9.0	5.1
	25.0	6.7	4.9	7.0	5.0	7.5	5.0	7.7	5.2	7.9	5.2	8.3	5.1	8.8	5.0
	27.5	6.7	4.9	6.9	5.0	7.3	4.9	7.5	5.2	7.7	5.1	8.1	5.1	8.7	5.0
	30.0	6.6	4.8	6.8	4.9	7.2	4.9	7.4	5.1	7.6	5.1	8.0	5.0	8.5	4.9
	32.5	6.5	4.7	6.7	4.9	7.1	4.8	7.2	5.1	7.4	5.0	7.8	4.9	8.3	4.9
	35.0	6.4	4.7	6.5	4.8	6.9	4.7	7.1	5.0	7.3	5.0	7.7	4.9	8.1	4.8
	37.5	6.2	4.6	6.4	4.7	6.8	4.7	7.0	4.9	7.2	4.9	7.5	4.8	8.0	4.7
	40.0	6.1	4.5	6.3	4.7	6.7	4.6	6.8	4.9	7.0	4.8	7.4	4.7	7.8	4.7
43.0	6.0	4.5	6.1	4.6	6.5	4.5	6.7	4.8	6.9	4.8	7.2	4.7	7.6	4.6	

kcal/h=kW x 860 , BTU/h = kW x 3,412

8. Cooling [Floor standing (Exposed 2-way/Exposed/Concealed type)]

8-2. Cooling capacity with PUHY-RP300-400Y(S)JM,PURY-RP300YJM

PFFY-P-VKM-E

CA:Capacity(kW) , SHC:Sensible Heat Capacity(kW)

Model size (Rated kW)	Outdoor air temp. °C D.B.	Indoor air temp.													
		21.5°C D.B. 15°C W.B.		23°C D.B. 16°C W.B.		25°C D.B. 18°C W.B.		27°C D.B. 19°C W.B.		28°C D.B. 20°C W.B.		30°C D.B. 22°C W.B.		32°C D.B. 24°C W.B.	
		CA	SHC	CA	SHC	CA	SHC	CA	SHC	CA	SHC	CA	SHC	CA	SHC
20 (2.2)	20.0	2.1	1.7	2.2	1.8	2.4	1.7	2.5	1.9	2.5	1.9	2.7	1.8	2.9	1.8
	22.5	2.1	1.7	2.2	1.7	2.3	1.7	2.4	1.8	2.5	1.8	2.6	1.8	2.8	1.8
	25.0	2.1	1.7	2.2	1.7	2.3	1.7	2.4	1.8	2.4	1.8	2.6	1.8	2.8	1.8
	27.5	2.1	1.7	2.1	1.7	2.3	1.7	2.3	1.8	2.4	1.8	2.5	1.8	2.7	1.8
	30.0	2.0	1.6	2.1	1.7	2.2	1.7	2.3	1.8	2.4	1.8	2.5	1.8	2.6	1.7
	32.5	2.0	1.6	2.0	1.7	2.2	1.7	2.2	1.8	2.3	1.8	2.4	1.7	2.6	1.7
	35.0	2.0	1.6	2.0	1.7	2.1	1.6	2.2	1.8	2.3	1.7	2.4	1.7	2.5	1.7
	37.5	1.9	1.6	2.0	1.6	2.1	1.6	2.1	1.7	2.2	1.7	2.3	1.7	2.5	1.7
	40.0	1.9	1.6	1.9	1.6	2.0	1.6	2.1	1.7	2.2	1.7	2.3	1.7	2.4	1.7
43.0	1.9	1.6	1.9	1.6	2.0	1.6	2.0	1.7	2.1	1.7	2.2	1.7	2.4	1.6	
25 (2.8)	20.0	2.7	2.0	2.8	2.1	3.0	2.1	3.1	2.2	3.2	2.2	3.4	2.2	3.6	2.1
	22.5	2.7	2.0	2.8	2.1	3.0	2.1	3.1	2.2	3.2	2.2	3.4	2.1	3.6	2.1
	25.0	2.7	2.0	2.7	2.0	2.9	2.0	3.0	2.2	3.1	2.1	3.3	2.1	3.5	2.1
	27.5	2.6	2.0	2.7	2.0	2.9	2.0	3.0	2.1	3.1	2.1	3.2	2.1	3.4	2.1
	30.0	2.6	2.0	2.6	2.0	2.8	2.0	2.9	2.1	3.0	2.1	3.2	2.1	3.4	2.0
	32.5	2.5	1.9	2.6	2.0	2.8	2.0	2.8	2.1	2.9	2.1	3.1	2.0	3.3	2.0
	35.0	2.5	1.9	2.5	1.9	2.7	1.9	2.8	2.1	2.9	2.0	3.0	2.0	3.2	2.0
	37.5	2.5	1.9	2.5	1.9	2.6	1.9	2.7	2.0	2.8	2.0	3.0	2.0	3.2	2.0
	40.0	2.4	1.9	2.4	1.9	2.6	1.9	2.7	2.0	2.8	2.0	2.9	2.0	3.1	1.9
43.0	2.4	1.8	2.4	1.9	2.5	1.9	2.6	2.0	2.7	2.0	2.8	1.9	3.0	1.9	
32 (3.6)	20.0	3.5	2.5	3.6	2.5	3.9	2.5	4.0	2.7	4.2	2.7	4.4	2.6	4.7	2.6
	22.5	3.5	2.5	3.6	2.5	3.8	2.5	4.0	2.6	4.1	2.6	4.3	2.6	4.6	2.5
	25.0	3.4	2.4	3.5	2.5	3.8	2.5	3.9	2.6	4.0	2.6	4.2	2.6	4.5	2.5
	27.5	3.4	2.4	3.5	2.5	3.7	2.4	3.8	2.6	3.9	2.6	4.2	2.5	4.4	2.5
	30.0	3.3	2.4	3.4	2.4	3.6	2.4	3.7	2.5	3.8	2.5	4.1	2.5	4.3	2.4
	32.5	3.3	2.3	3.3	2.4	3.5	2.4	3.7	2.5	3.8	2.5	4.0	2.5	4.2	2.4
	35.0	3.2	2.3	3.3	2.4	3.5	2.3	3.6	2.5	3.7	2.5	3.9	2.4	4.2	2.4
	37.5	3.2	2.3	3.2	2.3	3.4	2.3	3.5	2.4	3.6	2.4	3.8	2.4	4.1	2.3
	40.0	3.1	2.3	3.1	2.3	3.3	2.3	3.4	2.4	3.5	2.4	3.8	2.4	4.0	2.3
43.0	3.0	2.2	3.0	2.2	3.2	2.2	3.3	2.4	3.4	2.3	3.7	2.3	3.9	2.3	
40 (4.5)	20.0	4.4	3.0	4.5	3.1	4.9	3.1	5.0	3.3	5.2	3.3	5.5	3.2	5.8	3.2
	22.5	4.4	3.0	4.5	3.1	4.8	3.1	4.9	3.3	5.1	3.2	5.4	3.2	5.7	3.1
	25.0	4.3	3.0	4.4	3.1	4.7	3.1	4.9	3.2	5.0	3.2	5.3	3.1	5.6	3.1
	27.5	4.2	3.0	4.3	3.0	4.6	3.0	4.8	3.2	4.9	3.1	5.2	3.1	5.5	3.1
	30.0	4.1	2.9	4.2	3.0	4.5	3.0	4.7	3.1	4.8	3.1	5.1	3.1	5.4	3.0
	32.5	4.1	2.9	4.2	2.9	4.4	2.9	4.6	3.1	4.7	3.1	5.0	3.0	5.3	3.0
	35.0	4.0	2.9	4.1	2.9	4.3	2.9	4.5	3.0	4.6	3.0	4.9	3.0	5.2	2.9
	37.5	3.9	2.8	4.0	2.9	4.2	2.8	4.4	3.0	4.5	3.0	4.8	2.9	5.1	2.9
	40.0	3.9	2.8	3.9	2.8	4.2	2.8	4.3	2.9	4.4	2.9	4.7	2.9	5.0	2.8
43.0	3.8	2.7	3.8	2.8	4.0	2.7	4.2	2.9	4.3	2.9	4.6	2.8	4.8	2.8	

kcal/h=kW x 860 , BTU/h = kW x 3,412

8. Cooling [Floor standing (Exposed 2-way/Exposed/Concealed type)]

PFFY-P-VLEM-E,VLRM-E

CA:Capacity(kW) , SHC:Sensible Heat Capacity(kW)

Model size (Rated kW)	Outdoor air temp. °C D.B.	Indoor air temp.													
		21.5°C D.B. 15°C W.B.		23°C D.B. 16°C W.B.		25°C D.B. 18°C W.B.		27°C D.B. 19°C W.B.		28°C D.B. 20°C W.B.		30°C D.B. 22°C W.B.		32°C D.B. 24°C W.B.	
		CA	SHC	CA	SHC	CA	SHC	CA	SHC	CA	SHC	CA	SHC	CA	SHC
20 (2.2)	20.0	2.1	1.7	2.2	1.7	2.4	1.7	2.5	1.9	2.5	1.8	2.7	1.8	2.9	1.8
	22.5	2.1	1.7	2.2	1.7	2.3	1.7	2.4	1.8	2.5	1.8	2.6	1.8	2.8	1.8
	25.0	2.1	1.7	2.2	1.7	2.3	1.7	2.4	1.8	2.4	1.8	2.6	1.8	2.8	1.8
	27.5	2.1	1.6	2.1	1.7	2.3	1.7	2.3	1.8	2.4	1.8	2.5	1.8	2.7	1.7
	30.0	2.0	1.6	2.1	1.7	2.2	1.7	2.3	1.8	2.4	1.8	2.5	1.7	2.6	1.7
	32.5	2.0	1.6	2.0	1.7	2.2	1.6	2.2	1.8	2.3	1.8	2.4	1.7	2.6	1.7
	35.0	2.0	1.6	2.0	1.6	2.1	1.6	2.2	1.7	2.3	1.7	2.4	1.7	2.5	1.7
	37.5	1.9	1.6	2.0	1.6	2.1	1.6	2.1	1.7	2.2	1.7	2.3	1.7	2.5	1.7
	40.0	1.9	1.6	1.9	1.6	2.0	1.6	2.1	1.7	2.2	1.7	2.3	1.7	2.4	1.6
43.0	1.9	1.6	1.9	1.6	2.0	1.6	2.0	1.7	2.1	1.7	2.2	1.7	2.4	1.6	
25 (2.8)	20.0	2.7	2.0	2.8	2.0	3.0	2.0	3.1	2.1	3.2	2.1	3.4	2.1	3.6	2.1
	22.5	2.7	2.0	2.8	2.0	3.0	2.0	3.1	2.1	3.2	2.1	3.4	2.1	3.6	2.0
	25.0	2.7	1.9	2.7	2.0	2.9	2.0	3.0	2.1	3.1	2.1	3.3	2.1	3.5	2.0
	27.5	2.6	1.9	2.7	2.0	2.9	2.0	3.0	2.1	3.1	2.1	3.2	2.0	3.4	2.0
	30.0	2.6	1.9	2.6	1.9	2.8	1.9	2.9	2.0	3.0	2.0	3.2	2.0	3.4	2.0
	32.5	2.5	1.9	2.6	1.9	2.8	1.9	2.8	2.0	2.9	2.0	3.1	2.0	3.3	2.0
	35.0	2.5	1.9	2.5	1.9	2.7	1.9	2.8	2.0	2.9	2.0	3.0	2.0	3.2	1.9
	37.5	2.5	1.8	2.5	1.9	2.6	1.9	2.7	2.0	2.8	2.0	3.0	1.9	3.2	1.9
	40.0	2.4	1.8	2.4	1.8	2.6	1.8	2.7	1.9	2.8	1.9	2.9	1.9	3.1	1.9
43.0	2.4	1.8	2.4	1.8	2.5	1.8	2.6	1.9	2.7	1.9	2.8	1.9	3.0	1.8	
32 (3.6)	20.0	3.5	2.5	3.6	2.6	3.9	2.6	4.0	2.7	4.2	2.7	4.4	2.7	4.7	2.6
	22.5	3.5	2.5	3.6	2.6	3.8	2.6	4.0	2.7	4.1	2.7	4.3	2.7	4.6	2.6
	25.0	3.4	2.5	3.5	2.5	3.8	2.5	3.9	2.7	4.0	2.7	4.2	2.6	4.5	2.6
	27.5	3.4	2.5	3.5	2.5	3.7	2.5	3.8	2.6	3.9	2.6	4.2	2.6	4.4	2.6
	30.0	3.3	2.4	3.4	2.5	3.6	2.5	3.7	2.6	3.8	2.6	4.1	2.6	4.3	2.5
	32.5	3.3	2.4	3.3	2.4	3.5	2.4	3.7	2.6	3.8	2.6	4.0	2.5	4.2	2.5
	35.0	3.2	2.4	3.3	2.4	3.5	2.4	3.6	2.5	3.7	2.5	3.9	2.5	4.2	2.5
	37.5	3.2	2.3	3.2	2.4	3.4	2.4	3.5	2.5	3.6	2.5	3.8	2.5	4.1	2.4
	40.0	3.1	2.3	3.1	2.4	3.3	2.3	3.4	2.5	3.5	2.5	3.8	2.4	4.0	2.4
43.0	3.0	2.3	3.0	2.3	3.2	2.3	3.3	2.4	3.4	2.4	3.7	2.4	3.9	2.4	
40 (4.5)	20.0	4.4	3.2	4.5	3.3	4.9	3.3	5.0	3.4	5.2	3.4	5.5	3.4	5.8	3.3
	22.5	4.4	3.2	4.5	3.2	4.8	3.2	4.9	3.4	5.1	3.4	5.4	3.3	5.7	3.3
	25.0	4.3	3.1	4.4	3.2	4.7	3.2	4.9	3.4	5.0	3.3	5.3	3.3	5.6	3.2
	27.5	4.2	3.1	4.3	3.2	4.6	3.1	4.8	3.3	4.9	3.3	5.2	3.3	5.5	3.2
	30.0	4.1	3.0	4.2	3.1	4.5	3.1	4.7	3.3	4.8	3.3	5.1	3.2	5.4	3.2
	32.5	4.1	3.0	4.2	3.1	4.4	3.1	4.6	3.2	4.7	3.2	5.0	3.2	5.3	3.1
	35.0	4.0	3.0	4.1	3.0	4.3	3.0	4.5	3.2	4.6	3.2	4.9	3.1	5.2	3.1
	37.5	3.9	2.9	4.0	3.0	4.2	3.0	4.4	3.2	4.5	3.1	4.8	3.1	5.1	3.0
	40.0	3.9	2.9	3.9	3.0	4.2	2.9	4.3	3.1	4.4	3.1	4.7	3.1	5.0	3.0
43.0	3.8	2.9	3.8	2.9	4.0	2.9	4.2	3.1	4.3	3.0	4.6	3.0	4.8	3.0	
50 (5.6)	20.0	5.4	4.0	5.6	4.1	6.1	4.1	6.3	4.3	6.5	4.3	6.9	4.3	7.3	4.2
	22.5	5.4	4.0	5.6	4.1	6.0	4.1	6.2	4.3	6.3	4.3	6.7	4.2	7.1	4.2
	25.0	5.3	3.9	5.5	4.0	5.8	4.0	6.0	4.2	6.2	4.2	6.6	4.2	7.0	4.1
	27.5	5.3	3.9	5.4	4.0	5.7	4.0	5.9	4.2	6.1	4.2	6.5	4.1	6.9	4.1
	30.0	5.2	3.9	5.3	3.9	5.6	3.9	5.8	4.1	6.0	4.1	6.4	4.1	6.7	4.0
	32.5	5.1	3.8	5.2	3.9	5.5	3.9	5.7	4.1	5.9	4.1	6.2	4.0	6.6	4.0
	35.0	5.0	3.8	5.1	3.8	5.4	3.8	5.6	4.1	5.7	4.0	6.1	4.0	6.5	3.9
	37.5	4.9	3.7	5.0	3.8	5.3	3.8	5.5	4.0	5.6	4.0	6.0	3.9	6.3	3.9
	40.0	4.8	3.7	4.9	3.7	5.2	3.7	5.3	3.9	5.5	3.9	5.8	3.9	6.2	3.8
43.0	4.7	3.6	4.7	3.7	5.0	3.7	5.2	3.9	5.4	3.9	5.7	3.8	6.0	3.8	
63 (7.1)	20.0	6.9	4.9	7.1	5.1	7.7	5.1	7.9	5.4	8.2	5.3	8.7	5.3	9.2	5.2
	22.5	6.9	4.9	7.1	5.1	7.6	5.0	7.8	5.3	8.0	5.3	8.5	5.2	9.1	5.1
	25.0	6.8	4.9	7.0	5.0	7.4	5.0	7.7	5.2	7.9	5.2	8.4	5.1	8.9	5.1
	27.5	6.7	4.8	6.8	4.9	7.3	4.9	7.5	5.2	7.7	5.1	8.2	5.1	8.7	5.0
	30.0	6.5	4.8	6.7	4.9	7.1	4.8	7.4	5.1	7.6	5.1	8.1	5.0	8.5	4.9
	32.5	6.4	4.7	6.6	4.8	7.0	4.8	7.2	5.0	7.4	5.0	7.9	5.0	8.4	4.9
	35.0	6.3	4.7	6.4	4.7	6.8	4.7	7.1	5.0	7.3	5.0	7.7	4.9	8.2	4.8
	37.5	6.2	4.6	6.3	4.7	6.7	4.6	6.9	4.9	7.1	4.9	7.6	4.8	8.0	4.7
	40.0	6.1	4.5	6.2	4.6	6.6	4.6	6.8	4.8	7.0	4.8	7.4	4.8	7.8	4.7
43.0	6.0	4.5	6.0	4.5	6.4	4.5	6.6	4.8	6.8	4.7	7.2	4.7	7.6	4.6	

kcal/h=kW x 860 , BTU/h = kW x 3,412

8. Cooling [Floor standing (Exposed 2-way/Exposed/Concealed type)]

PFFY-P-VLRMM-E

CA:Capacity(kW) , SHC:Sensible Heat Capacity(kW)

Model size (Rated kW)	Outdoor air temp. °C D.B.	Indoor air temp.													
		21.5°C D.B. 15°C W.B.		23°C D.B. 16°C W.B.		25°C D.B. 18°C W.B.		27°C D.B. 19°C W.B.		28°C D.B. 20°C W.B.		30°C D.B. 22°C W.B.		32°C D.B. 24°C W.B.	
		CA	SHC	CA	SHC	CA	SHC	CA	SHC	CA	SHC	CA	SHC	CA	SHC
20 (2.2)	20.0	2.1	1.7	2.2	1.7	2.4	1.7	2.5	1.9	2.5	1.8	2.7	1.8	2.9	1.8
	22.5	2.1	1.7	2.2	1.7	2.3	1.7	2.4	1.8	2.5	1.8	2.6	1.8	2.8	1.8
	25.0	2.1	1.7	2.2	1.7	2.3	1.7	2.4	1.8	2.4	1.8	2.6	1.8	2.8	1.8
	27.5	2.1	1.6	2.1	1.7	2.3	1.7	2.3	1.8	2.4	1.8	2.5	1.8	2.7	1.7
	30.0	2.0	1.6	2.1	1.7	2.2	1.7	2.3	1.8	2.4	1.8	2.5	1.7	2.6	1.7
	32.5	2.0	1.6	2.0	1.7	2.2	1.6	2.2	1.8	2.3	1.8	2.4	1.7	2.6	1.7
	35.0	2.0	1.6	2.0	1.6	2.1	1.6	2.2	1.7	2.3	1.7	2.4	1.7	2.5	1.7
	37.5	1.9	1.6	2.0	1.6	2.1	1.6	2.1	1.7	2.2	1.7	2.3	1.7	2.5	1.7
	40.0	1.9	1.6	1.9	1.6	2.0	1.6	2.1	1.7	2.2	1.7	2.3	1.7	2.4	1.6
43.0	1.9	1.6	1.9	1.6	2.0	1.6	2.0	1.7	2.1	1.7	2.2	1.7	2.4	1.6	
25 (2.8)	20.0	2.7	2.0	2.8	2.0	3.0	2.0	3.1	2.1	3.2	2.1	3.4	2.1	3.6	2.1
	22.5	2.7	2.0	2.8	2.0	3.0	2.0	3.1	2.1	3.2	2.1	3.4	2.1	3.6	2.0
	25.0	2.7	1.9	2.7	2.0	2.9	2.0	3.0	2.1	3.1	2.1	3.3	2.1	3.5	2.0
	27.5	2.6	1.9	2.7	2.0	2.9	2.0	3.0	2.1	3.1	2.1	3.2	2.0	3.4	2.0
	30.0	2.6	1.9	2.6	1.9	2.8	1.9	2.9	2.0	3.0	2.0	3.2	2.0	3.4	2.0
	32.5	2.5	1.9	2.6	1.9	2.8	1.9	2.8	2.0	2.9	2.0	3.1	2.0	3.3	2.0
	35.0	2.5	1.9	2.5	1.9	2.7	1.9	2.8	2.0	2.9	2.0	3.0	2.0	3.2	1.9
	37.5	2.5	1.8	2.5	1.9	2.6	1.9	2.7	2.0	2.8	2.0	3.0	1.9	3.2	1.9
	40.0	2.4	1.8	2.4	1.8	2.6	1.8	2.7	1.9	2.8	1.9	2.9	1.9	3.1	1.9
43.0	2.4	1.8	2.4	1.8	2.5	1.8	2.6	1.9	2.7	1.9	2.8	1.9	3.0	1.8	
32 (3.6)	20.0	3.5	2.5	3.6	2.6	3.9	2.6	4.0	2.7	4.2	2.7	4.4	2.7	4.7	2.6
	22.5	3.5	2.5	3.6	2.6	3.8	2.6	4.0	2.7	4.1	2.7	4.3	2.7	4.6	2.6
	25.0	3.4	2.5	3.5	2.5	3.8	2.5	3.9	2.7	4.0	2.7	4.2	2.6	4.5	2.6
	27.5	3.4	2.5	3.5	2.5	3.7	2.5	3.8	2.6	3.9	2.6	4.2	2.6	4.4	2.6
	30.0	3.3	2.4	3.4	2.5	3.6	2.5	3.7	2.6	3.8	2.6	4.1	2.6	4.3	2.5
	32.5	3.3	2.4	3.3	2.4	3.5	2.4	3.7	2.6	3.8	2.6	4.0	2.5	4.2	2.5
	35.0	3.2	2.4	3.3	2.4	3.5	2.4	3.6	2.5	3.7	2.5	3.9	2.5	4.2	2.5
	37.5	3.2	2.3	3.2	2.4	3.4	2.4	3.5	2.5	3.6	2.5	3.8	2.5	4.1	2.4
	40.0	3.1	2.3	3.1	2.4	3.3	2.3	3.4	2.5	3.5	2.5	3.8	2.4	4.0	2.4
43.0	3.0	2.3	3.0	2.3	3.2	2.3	3.3	2.4	3.4	2.4	3.7	2.4	3.9	2.4	
40 (4.5)	20.0	4.4	3.2	4.5	3.3	4.9	3.3	5.0	3.4	5.2	3.4	5.5	3.4	5.8	3.3
	22.5	4.4	3.2	4.5	3.2	4.8	3.2	4.9	3.4	5.1	3.4	5.4	3.3	5.7	3.3
	25.0	4.3	3.1	4.4	3.2	4.7	3.2	4.9	3.4	5.0	3.3	5.3	3.3	5.6	3.2
	27.5	4.2	3.1	4.3	3.2	4.6	3.1	4.8	3.3	4.9	3.3	5.2	3.3	5.5	3.2
	30.0	4.1	3.0	4.2	3.1	4.5	3.1	4.7	3.3	4.8	3.3	5.1	3.2	5.4	3.2
	32.5	4.1	3.0	4.2	3.1	4.4	3.1	4.6	3.2	4.7	3.2	5.0	3.2	5.3	3.1
	35.0	4.0	3.0	4.1	3.0	4.3	3.0	4.5	3.2	4.6	3.2	4.9	3.1	5.2	3.1
	37.5	3.9	2.9	4.0	3.0	4.2	3.0	4.4	3.2	4.5	3.1	4.8	3.1	5.1	3.0
	40.0	3.9	2.9	3.9	3.0	4.2	2.9	4.3	3.1	4.4	3.1	4.7	3.1	5.0	3.0
43.0	3.8	2.9	3.8	2.9	4.0	2.9	4.2	3.1	4.3	3.0	4.6	3.0	4.8	3.0	
50 (5.6)	20.0	5.4	4.0	5.6	4.1	6.1	4.1	6.3	4.3	6.5	4.3	6.9	4.3	7.3	4.2
	22.5	5.4	4.0	5.6	4.1	6.0	4.1	6.2	4.3	6.3	4.3	6.7	4.2	7.1	4.2
	25.0	5.3	3.9	5.5	4.0	5.8	4.0	6.0	4.2	6.2	4.2	6.6	4.2	7.0	4.1
	27.5	5.3	3.9	5.4	4.0	5.7	4.0	5.9	4.2	6.1	4.2	6.5	4.1	6.9	4.1
	30.0	5.2	3.9	5.3	3.9	5.6	3.9	5.8	4.1	6.0	4.1	6.4	4.1	6.7	4.0
	32.5	5.1	3.8	5.2	3.9	5.5	3.9	5.7	4.1	5.9	4.1	6.2	4.0	6.6	4.0
	35.0	5.0	3.8	5.1	3.8	5.4	3.8	5.6	4.1	5.7	4.0	6.1	4.0	6.5	3.9
	37.5	4.9	3.7	5.0	3.8	5.3	3.8	5.5	4.0	5.6	4.0	6.0	3.9	6.3	3.9
	40.0	4.8	3.7	4.9	3.7	5.2	3.7	5.3	3.9	5.5	3.9	5.8	3.9	6.2	3.8
43.0	4.7	3.6	4.7	3.7	5.0	3.7	5.2	3.9	5.4	3.9	5.7	3.8	6.0	3.8	
63 (7.1)	20.0	6.9	4.9	7.1	5.1	7.7	5.1	7.9	5.4	8.2	5.3	8.7	5.3	9.2	5.2
	22.5	6.9	4.9	7.1	5.1	7.6	5.0	7.8	5.3	8.0	5.3	8.5	5.2	9.1	5.1
	25.0	6.8	4.9	7.0	5.0	7.4	5.0	7.7	5.2	7.9	5.2	8.4	5.1	8.9	5.1
	27.5	6.7	4.8	6.8	4.9	7.3	4.9	7.5	5.2	7.7	5.1	8.2	5.1	8.7	5.0
	30.0	6.5	4.8	6.7	4.9	7.1	4.8	7.4	5.1	7.6	5.1	8.1	5.0	8.5	4.9
	32.5	6.4	4.7	6.6	4.8	7.0	4.8	7.2	5.0	7.4	5.0	7.9	5.0	8.4	4.9
	35.0	6.3	4.7	6.4	4.7	6.8	4.7	7.1	5.0	7.3	5.0	7.7	4.9	8.2	4.8
	37.5	6.2	4.6	6.3	4.7	6.7	4.6	6.9	4.9	7.1	4.9	7.6	4.8	8.0	4.7
	40.0	6.1	4.5	6.2	4.6	6.6	4.6	6.8	4.8	7.0	4.8	7.4	4.8	7.8	4.7
43.0	6.0	4.5	6.0	4.5	6.4	4.5	6.6	4.8	6.8	4.7	7.2	4.7	7.6	4.6	

kcal/h=kW x 860 , BTU/h = kW x 3,412

8. Cooling [Floor standing (Exposed 2-way/Exposed/Concealed type)]

8-3. Cooling capacity with PUHY-RP450-650YSJM

PFFY-P-VKM-E

CA:Capacity(kW) , SHC:Sensible Heat Capacity(kW)

Model size (Rated kW)	Outdoor air temp. °C D.B.	Indoor air temp.													
		21.5°C D.B. 15°C W.B.		23°C D.B. 16°C W.B.		25°C D.B. 18°C W.B.		27°C D.B. 19°C W.B.		28°C D.B. 20°C W.B.		30°C D.B. 22°C W.B.		32°C D.B. 24°C W.B.	
		CA	SHC	CA	SHC	CA	SHC	CA	SHC	CA	SHC	CA	SHC	CA	SHC
20 (2.2)	20.0	2.1	1.7	2.1	1.7	2.3	1.7	2.4	1.8	2.4	1.8	2.6	1.8	2.8	1.8
	22.5	2.1	1.7	2.1	1.7	2.3	1.7	2.3	1.8	2.4	1.8	2.6	1.8	2.7	1.8
	25.0	2.0	1.6	2.1	1.7	2.2	1.7	2.3	1.8	2.4	1.8	2.5	1.8	2.7	1.8
	27.5	2.0	1.6	2.1	1.7	2.2	1.7	2.3	1.8	2.4	1.8	2.5	1.8	2.7	1.8
	30.0	2.0	1.6	2.0	1.7	2.2	1.7	2.3	1.8	2.3	1.8	2.5	1.8	2.7	1.7
	32.5	2.0	1.6	2.0	1.7	2.2	1.7	2.2	1.8	2.3	1.8	2.5	1.8	2.6	1.7
	35.0	2.0	1.6	2.0	1.7	2.1	1.6	2.2	1.8	2.3	1.8	2.5	1.7	2.6	1.7
	37.5	1.9	1.6	2.0	1.6	2.1	1.6	2.2	1.8	2.3	1.8	2.4	1.7	2.6	1.7
	40.0	1.9	1.6	1.9	1.6	2.1	1.6	2.2	1.7	2.2	1.7	2.4	1.7	2.6	1.7
43.0	1.9	1.6	1.9	1.6	2.1	1.6	2.1	1.7	2.2	1.7	2.4	1.7	2.5	1.7	
25 (2.8)	20.0	2.6	2.0	2.7	2.0	2.9	2.0	3.0	2.2	3.1	2.1	3.3	2.1	3.5	2.1
	22.5	2.6	2.0	2.7	2.0	2.9	2.0	3.0	2.1	3.1	2.1	3.3	2.1	3.5	2.1
	25.0	2.6	2.0	2.7	2.0	2.9	2.0	2.9	2.1	3.0	2.1	3.2	2.1	3.5	2.1
	27.5	2.6	1.9	2.6	2.0	2.8	2.0	2.9	2.1	3.0	2.1	3.2	2.1	3.4	2.1
	30.0	2.5	1.9	2.6	2.0	2.8	2.0	2.9	2.1	3.0	2.1	3.2	2.1	3.4	2.0
	32.5	2.5	1.9	2.6	2.0	2.8	2.0	2.9	2.1	3.0	2.1	3.2	2.1	3.4	2.0
	35.0	2.5	1.9	2.5	1.9	2.7	1.9	2.8	2.1	2.9	2.1	3.1	2.0	3.3	2.0
	37.5	2.5	1.9	2.5	1.9	2.7	1.9	2.8	2.1	2.9	2.1	3.1	2.0	3.3	2.0
	40.0	2.4	1.9	2.5	1.9	2.7	1.9	2.8	2.0	2.9	2.0	3.1	2.0	3.3	2.0
43.0	2.4	1.9	2.4	1.9	2.6	1.9	2.7	2.0	2.8	2.0	3.0	2.0	3.2	2.0	
32 (3.6)	20.0	3.4	2.4	3.5	2.5	3.7	2.5	3.9	2.6	4.0	2.6	4.3	2.6	4.5	2.5
	22.5	3.4	2.4	3.5	2.5	3.7	2.4	3.8	2.6	4.0	2.6	4.2	2.5	4.5	2.5
	25.0	3.3	2.4	3.4	2.4	3.7	2.4	3.8	2.6	3.9	2.5	4.2	2.5	4.4	2.5
	27.5	3.3	2.4	3.4	2.4	3.6	2.4	3.8	2.5	3.9	2.5	4.1	2.5	4.4	2.5
	30.0	3.3	2.3	3.3	2.4	3.6	2.4	3.7	2.5	3.8	2.5	4.1	2.5	4.4	2.5
	32.5	3.2	2.3	3.3	2.4	3.5	2.4	3.7	2.5	3.8	2.5	4.1	2.5	4.3	2.4
	35.0	3.2	2.3	3.3	2.4	3.5	2.3	3.6	2.5	3.8	2.5	4.0	2.5	4.3	2.4
	37.5	3.2	2.3	3.2	2.3	3.5	2.3	3.6	2.5	3.7	2.5	4.0	2.4	4.2	2.4
	40.0	3.1	2.3	3.2	2.3	3.4	2.3	3.5	2.4	3.7	2.4	3.9	2.4	4.2	2.4
43.0	3.1	2.3	3.1	2.3	3.4	2.3	3.5	2.4	3.6	2.4	3.9	2.4	4.2	2.4	
40 (4.5)	20.0	4.3	3.0	4.4	3.1	4.7	3.0	4.8	3.2	5.0	3.2	5.3	3.2	5.7	3.1
	22.5	4.2	3.0	4.3	3.0	4.6	3.0	4.8	3.2	4.9	3.2	5.3	3.1	5.6	3.1
	25.0	4.2	2.9	4.3	3.0	4.6	3.0	4.7	3.2	4.9	3.1	5.2	3.1	5.6	3.1
	27.5	4.1	2.9	4.2	3.0	4.5	3.0	4.7	3.1	4.8	3.1	5.2	3.1	5.5	3.1
	30.0	4.1	2.9	4.2	2.9	4.5	2.9	4.6	3.1	4.8	3.1	5.1	3.1	5.5	3.0
	32.5	4.0	2.9	4.1	2.9	4.4	2.9	4.6	3.1	4.7	3.1	5.1	3.0	5.4	3.0
	35.0	4.0	2.8	4.1	2.9	4.4	2.9	4.5	3.0	4.7	3.0	5.0	3.0	5.4	3.0
	37.5	4.0	2.8	4.0	2.9	4.3	2.9	4.5	3.0	4.6	3.0	5.0	3.0	5.3	3.0
	40.0	3.9	2.8	4.0	2.8	4.3	2.8	4.4	3.0	4.6	3.0	4.9	3.0	5.3	3.0
43.0	3.9	2.8	3.9	2.8	4.2	2.8	4.4	3.0	4.5	3.0	4.9	3.0	5.2	2.9	

kcal/h=kW x 860 , BTU/h = kW x 3,412

8. Cooling [Floor standing (Exposed 2-way/Exposed/Concealed type)]

PFFY-P-VLEM-E,VLRM-E

CA:Capacity(kW) , SHC:Sensible Heat Capacity(kW)

Model size (Rated kW)	Outdoor air temp. °C D.B.	Indoor air temp.													
		21.5°C D.B. 15°C W.B.		23°C D.B. 16°C W.B.		25°C D.B. 18°C W.B.		27°C D.B. 19°C W.B.		28°C D.B. 20°C W.B.		30°C D.B. 22°C W.B.		32°C D.B. 24°C W.B.	
		CA	SHC	CA	SHC	CA	SHC	CA	SHC	CA	SHC	CA	SHC	CA	SHC
20 (2.2)	20.0	2.1	1.7	2.1	1.7	2.3	1.7	2.4	1.8	2.4	1.8	2.6	1.8	2.8	1.8
	22.5	2.1	1.6	2.1	1.7	2.3	1.7	2.3	1.8	2.4	1.8	2.6	1.8	2.7	1.8
	25.0	2.0	1.6	2.1	1.7	2.2	1.7	2.3	1.8	2.4	1.8	2.5	1.8	2.7	1.7
	27.5	2.0	1.6	2.1	1.7	2.2	1.7	2.3	1.8	2.4	1.8	2.5	1.8	2.7	1.7
	30.0	2.0	1.6	2.0	1.7	2.2	1.7	2.3	1.8	2.3	1.8	2.5	1.7	2.7	1.7
	32.5	2.0	1.6	2.0	1.7	2.2	1.6	2.2	1.8	2.3	1.8	2.5	1.7	2.6	1.7
	35.0	2.0	1.6	2.0	1.6	2.1	1.6	2.2	1.7	2.3	1.7	2.5	1.7	2.6	1.7
	37.5	1.9	1.6	2.0	1.6	2.1	1.6	2.2	1.7	2.3	1.7	2.4	1.7	2.6	1.7
	40.0	1.9	1.6	1.9	1.6	2.1	1.6	2.2	1.7	2.2	1.7	2.4	1.7	2.6	1.7
43.0	1.9	1.6	1.9	1.6	2.1	1.6	2.1	1.7	2.2	1.7	2.4	1.7	2.5	1.7	
25 (2.8)	20.0	2.6	1.9	2.7	2.0	2.9	2.0	3.0	2.1	3.1	2.1	3.3	2.1	3.5	2.0
	22.5	2.6	1.9	2.7	2.0	2.9	2.0	3.0	2.1	3.1	2.1	3.3	2.0	3.5	2.0
	25.0	2.6	1.9	2.7	2.0	2.9	1.9	2.9	2.1	3.0	2.1	3.2	2.0	3.5	2.0
	27.5	2.6	1.9	2.6	1.9	2.8	1.9	2.9	2.0	3.0	2.0	3.2	2.0	3.4	2.0
	30.0	2.5	1.9	2.6	1.9	2.8	1.9	2.9	2.0	3.0	2.0	3.2	2.0	3.4	2.0
	32.5	2.5	1.9	2.6	1.9	2.8	1.9	2.9	2.0	3.0	2.0	3.2	2.0	3.4	2.0
	35.0	2.5	1.9	2.5	1.9	2.7	1.9	2.8	2.0	2.9	2.0	3.1	2.0	3.3	2.0
	37.5	2.5	1.8	2.5	1.9	2.7	1.9	2.8	2.0	2.9	2.0	3.1	2.0	3.3	2.0
	40.0	2.4	1.8	2.5	1.9	2.7	1.9	2.8	2.0	2.9	2.0	3.1	2.0	3.3	1.9
43.0	2.4	1.8	2.4	1.8	2.6	1.8	2.7	2.0	2.8	2.0	3.0	1.9	3.2	1.9	
32 (3.6)	20.0	3.4	2.5	3.5	2.5	3.7	2.5	3.9	2.7	4.0	2.7	4.3	2.6	4.5	2.6
	22.5	3.4	2.5	3.5	2.5	3.7	2.5	3.8	2.6	4.0	2.6	4.2	2.6	4.5	2.6
	25.0	3.3	2.4	3.4	2.5	3.7	2.5	3.8	2.6	3.9	2.6	4.2	2.6	4.4	2.6
	27.5	3.3	2.4	3.4	2.5	3.6	2.5	3.8	2.6	3.9	2.6	4.1	2.6	4.4	2.5
	30.0	3.3	2.4	3.3	2.5	3.6	2.4	3.7	2.6	3.8	2.6	4.1	2.6	4.4	2.5
	32.5	3.2	2.4	3.3	2.4	3.5	2.4	3.7	2.6	3.8	2.6	4.1	2.5	4.3	2.5
	35.0	3.2	2.4	3.3	2.4	3.5	2.4	3.6	2.5	3.8	2.6	4.0	2.5	4.3	2.5
	37.5	3.2	2.3	3.2	2.4	3.5	2.4	3.6	2.5	3.7	2.5	4.0	2.5	4.2	2.5
	40.0	3.1	2.3	3.2	2.4	3.4	2.4	3.5	2.5	3.7	2.5	3.9	2.5	4.2	2.5
43.0	3.1	2.3	3.1	2.4	3.4	2.4	3.5	2.5	3.6	2.5	3.9	2.5	4.2	2.5	
40 (4.5)	20.0	4.3	3.1	4.4	3.2	4.7	3.2	4.8	3.4	5.0	3.3	5.3	3.3	5.7	3.3
	22.5	4.2	3.1	4.3	3.2	4.6	3.1	4.8	3.3	4.9	3.3	5.3	3.3	5.6	3.2
	25.0	4.2	3.1	4.3	3.1	4.6	3.1	4.7	3.3	4.9	3.3	5.2	3.3	5.6	3.2
	27.5	4.1	3.0	4.2	3.1	4.5	3.1	4.7	3.3	4.8	3.3	5.2	3.2	5.5	3.2
	30.0	4.1	3.0	4.2	3.1	4.5	3.1	4.6	3.3	4.8	3.2	5.1	3.2	5.5	3.2
	32.5	4.0	3.0	4.1	3.1	4.4	3.1	4.6	3.2	4.7	3.2	5.1	3.2	5.4	3.2
	35.0	4.0	3.0	4.1	3.0	4.4	3.0	4.5	3.2	4.7	3.2	5.0	3.2	5.4	3.1
	37.5	4.0	3.0	4.0	3.0	4.3	3.0	4.5	3.2	4.6	3.2	5.0	3.2	5.3	3.1
	40.0	3.9	2.9	4.0	3.0	4.3	3.0	4.4	3.2	4.6	3.2	4.9	3.1	5.3	3.1
43.0	3.9	2.9	3.9	3.0	4.2	3.0	4.4	3.1	4.5	3.1	4.9	3.1	5.2	3.1	
50 (5.6)	20.0	5.3	3.9	5.5	4.0	5.8	4.0	6.0	4.2	6.2	4.2	6.6	4.2	7.0	4.1
	22.5	5.2	3.9	5.4	4.0	5.8	4.0	6.0	4.2	6.2	4.2	6.6	4.2	7.0	4.1
	25.0	5.2	3.9	5.3	4.0	5.7	3.9	5.9	4.2	6.1	4.2	6.5	4.1	6.9	4.1
	27.5	5.1	3.8	5.3	3.9	5.6	3.9	5.8	4.2	6.0	4.1	6.4	4.1	6.9	4.1
	30.0	5.1	3.8	5.2	3.9	5.6	3.9	5.8	4.1	6.0	4.1	6.4	4.1	6.8	4.0
	32.5	5.0	3.8	5.1	3.9	5.5	3.9	5.7	4.1	5.9	4.1	6.3	4.1	6.7	4.0
	35.0	5.0	3.8	5.1	3.8	5.4	3.8	5.6	4.1	5.8	4.1	6.2	4.0	6.7	4.0
	37.5	4.9	3.7	5.0	3.8	5.4	3.8	5.6	4.1	5.8	4.0	6.2	4.0	6.6	4.0
	40.0	4.9	3.7	4.9	3.8	5.3	3.8	5.5	4.0	5.7	4.0	6.1	4.0	6.5	3.9
43.0	4.8	3.7	4.9	3.7	5.2	3.7	5.4	4.0	5.6	4.0	6.0	4.0	6.5	3.9	
63 (7.1)	20.0	6.7	4.8	6.9	5.0	7.4	5.0	7.6	5.2	7.9	5.2	8.4	5.1	8.9	5.1
	22.5	6.6	4.8	6.8	4.9	7.3	4.9	7.6	5.2	7.8	5.2	8.3	5.1	8.8	5.0
	25.0	6.6	4.8	6.8	4.9	7.2	4.9	7.5	5.2	7.7	5.1	8.2	5.1	8.8	5.0
	27.5	6.5	4.7	6.7	4.9	7.2	4.8	7.4	5.1	7.6	5.1	8.2	5.1	8.7	5.0
	30.0	6.4	4.7	6.6	4.8	7.1	4.8	7.3	5.1	7.6	5.1	8.1	5.0	8.6	5.0
	32.5	6.4	4.7	6.5	4.8	7.0	4.8	7.2	5.1	7.5	5.0	8.0	5.0	8.5	4.9
	35.0	6.3	4.6	6.4	4.7	6.9	4.7	7.1	5.0	7.4	5.0	7.9	5.0	8.5	4.9
	37.5	6.2	4.6	6.3	4.7	6.8	4.7	7.1	5.0	7.3	5.0	7.8	4.9	8.4	4.9
	40.0	6.2	4.6	6.3	4.7	6.7	4.7	7.0	4.9	7.2	4.9	7.8	4.9	8.3	4.9
43.0	6.1	4.5	6.2	4.6	6.7	4.6	6.9	4.9	7.1	4.9	7.7	4.9	8.2	4.8	

kcal/h=kW x 860 , BTU/h = kW x 3,412

8. Cooling [Floor standing (Exposed 2-way/Exposed/Concealed type)]

PFFY-P-VLRMM-E

CA:Capacity(kW) , SHC:Sensible Heat Capacity(kW)

Model size (Rated kW)	Outdoor air temp. °C D.B.	Indoor air temp.													
		21.5°C D.B. 15°C W.B.		23°C D.B. 16°C W.B.		25°C D.B. 18°C W.B.		27°C D.B. 19°C W.B.		28°C D.B. 20°C W.B.		30°C D.B. 22°C W.B.		32°C D.B. 24°C W.B.	
		CA	SHC	CA	SHC	CA	SHC	CA	SHC	CA	SHC	CA	SHC	CA	SHC
20 (2.2)	20.0	2.1	1.7	2.1	1.7	2.3	1.7	2.4	1.8	2.4	1.8	2.6	1.8	2.8	1.8
	22.5	2.1	1.6	2.1	1.7	2.3	1.7	2.3	1.8	2.4	1.8	2.6	1.8	2.7	1.8
	25.0	2.0	1.6	2.1	1.7	2.2	1.7	2.3	1.8	2.4	1.8	2.5	1.8	2.7	1.7
	27.5	2.0	1.6	2.1	1.7	2.2	1.7	2.3	1.8	2.4	1.8	2.5	1.8	2.7	1.7
	30.0	2.0	1.6	2.0	1.7	2.2	1.7	2.3	1.8	2.3	1.8	2.5	1.7	2.7	1.7
	32.5	2.0	1.6	2.0	1.7	2.2	1.6	2.2	1.8	2.3	1.8	2.5	1.7	2.6	1.7
	35.0	2.0	1.6	2.0	1.6	2.1	1.6	2.2	1.7	2.3	1.7	2.5	1.7	2.6	1.7
	37.5	1.9	1.6	2.0	1.6	2.1	1.6	2.2	1.7	2.3	1.7	2.4	1.7	2.6	1.7
	40.0	1.9	1.6	1.9	1.6	2.1	1.6	2.2	1.7	2.2	1.7	2.4	1.7	2.6	1.7
43.0	1.9	1.6	1.9	1.6	2.1	1.6	2.1	1.7	2.2	1.7	2.4	1.7	2.5	1.7	
25 (2.8)	20.0	2.6	1.9	2.7	2.0	2.9	2.0	3.0	2.1	3.1	2.1	3.3	2.1	3.5	2.0
	22.5	2.6	1.9	2.7	2.0	2.9	2.0	3.0	2.1	3.1	2.1	3.3	2.0	3.5	2.0
	25.0	2.6	1.9	2.7	2.0	2.9	1.9	2.9	2.1	3.0	2.1	3.2	2.0	3.5	2.0
	27.5	2.6	1.9	2.6	1.9	2.8	1.9	2.9	2.0	3.0	2.0	3.2	2.0	3.4	2.0
	30.0	2.5	1.9	2.6	1.9	2.8	1.9	2.9	2.0	3.0	2.0	3.2	2.0	3.4	2.0
	32.5	2.5	1.9	2.6	1.9	2.8	1.9	2.9	2.0	3.0	2.0	3.2	2.0	3.4	2.0
	35.0	2.5	1.9	2.5	1.9	2.7	1.9	2.8	2.0	2.9	2.0	3.1	2.0	3.3	2.0
	37.5	2.5	1.8	2.5	1.9	2.7	1.9	2.8	2.0	2.9	2.0	3.1	2.0	3.3	2.0
	40.0	2.4	1.8	2.5	1.9	2.7	1.9	2.8	2.0	2.9	2.0	3.1	2.0	3.3	1.9
43.0	2.4	1.8	2.4	1.8	2.6	1.8	2.7	2.0	2.8	2.0	3.0	1.9	3.2	1.9	
32 (3.6)	20.0	3.4	2.5	3.5	2.5	3.7	2.5	3.9	2.7	4.0	2.7	4.3	2.6	4.5	2.6
	22.5	3.4	2.5	3.5	2.5	3.7	2.5	3.8	2.6	4.0	2.6	4.2	2.6	4.5	2.6
	25.0	3.3	2.4	3.4	2.5	3.7	2.5	3.8	2.6	3.9	2.6	4.2	2.6	4.4	2.6
	27.5	3.3	2.4	3.4	2.5	3.6	2.5	3.8	2.6	3.9	2.6	4.1	2.6	4.4	2.5
	30.0	3.3	2.4	3.3	2.5	3.6	2.4	3.7	2.6	3.8	2.6	4.1	2.6	4.4	2.5
	32.5	3.2	2.4	3.3	2.4	3.5	2.4	3.7	2.6	3.8	2.6	4.1	2.5	4.3	2.5
	35.0	3.2	2.4	3.3	2.4	3.5	2.4	3.6	2.5	3.8	2.6	4.0	2.5	4.3	2.5
	37.5	3.2	2.3	3.2	2.4	3.5	2.4	3.6	2.5	3.7	2.5	4.0	2.5	4.2	2.5
	40.0	3.1	2.3	3.2	2.4	3.4	2.4	3.5	2.5	3.7	2.5	3.9	2.5	4.2	2.5
43.0	3.1	2.3	3.1	2.4	3.4	2.4	3.5	2.5	3.6	2.5	3.9	2.5	4.2	2.5	
40 (4.5)	20.0	4.3	3.1	4.4	3.2	4.7	3.2	4.8	3.4	5.0	3.3	5.3	3.3	5.7	3.3
	22.5	4.2	3.1	4.3	3.2	4.6	3.1	4.8	3.3	4.9	3.3	5.3	3.3	5.6	3.2
	25.0	4.2	3.1	4.3	3.1	4.6	3.1	4.7	3.3	4.9	3.3	5.2	3.3	5.6	3.2
	27.5	4.1	3.0	4.2	3.1	4.5	3.1	4.7	3.3	4.8	3.3	5.2	3.2	5.5	3.2
	30.0	4.1	3.0	4.2	3.1	4.5	3.1	4.6	3.3	4.8	3.2	5.1	3.2	5.5	3.2
	32.5	4.0	3.0	4.1	3.1	4.4	3.1	4.6	3.2	4.7	3.2	5.1	3.2	5.4	3.2
	35.0	4.0	3.0	4.1	3.0	4.4	3.0	4.5	3.2	4.7	3.2	5.0	3.2	5.4	3.1
	37.5	4.0	3.0	4.0	3.0	4.3	3.0	4.5	3.2	4.6	3.2	5.0	3.2	5.3	3.1
	40.0	3.9	2.9	4.0	3.0	4.3	3.0	4.4	3.2	4.6	3.2	4.9	3.1	5.3	3.1
43.0	3.9	2.9	3.9	3.0	4.2	3.0	4.4	3.1	4.5	3.1	4.9	3.1	5.2	3.1	
50 (5.6)	20.0	5.3	3.9	5.5	4.0	5.8	4.0	6.0	4.2	6.2	4.2	6.6	4.2	7.0	4.1
	22.5	5.2	3.9	5.4	4.0	5.8	4.0	6.0	4.2	6.2	4.2	6.6	4.2	7.0	4.1
	25.0	5.2	3.9	5.3	4.0	5.7	3.9	5.9	4.2	6.1	4.2	6.5	4.1	6.9	4.1
	27.5	5.1	3.8	5.3	3.9	5.6	3.9	5.8	4.2	6.0	4.1	6.4	4.1	6.9	4.1
	30.0	5.1	3.8	5.2	3.9	5.6	3.9	5.8	4.1	6.0	4.1	6.4	4.1	6.8	4.0
	32.5	5.0	3.8	5.1	3.9	5.5	3.9	5.7	4.1	5.9	4.1	6.3	4.1	6.7	4.0
	35.0	5.0	3.8	5.1	3.8	5.4	3.8	5.6	4.1	5.8	4.1	6.2	4.0	6.7	4.0
	37.5	4.9	3.7	5.0	3.8	5.4	3.8	5.6	4.1	5.8	4.0	6.2	4.0	6.6	4.0
	40.0	4.9	3.7	4.9	3.8	5.3	3.8	5.5	4.0	5.7	4.0	6.1	4.0	6.5	3.9
43.0	4.8	3.7	4.9	3.7	5.2	3.7	5.4	4.0	5.6	4.0	6.0	4.0	6.5	3.9	
63 (7.1)	20.0	6.7	4.8	6.9	5.0	7.4	5.0	7.6	5.2	7.9	5.2	8.4	5.1	8.9	5.1
	22.5	6.6	4.8	6.8	4.9	7.3	4.9	7.6	5.2	7.8	5.2	8.3	5.1	8.8	5.0
	25.0	6.6	4.8	6.8	4.9	7.2	4.9	7.5	5.2	7.7	5.1	8.2	5.1	8.8	5.0
	27.5	6.5	4.7	6.7	4.9	7.2	4.8	7.4	5.1	7.6	5.1	8.2	5.1	8.7	5.0
	30.0	6.4	4.7	6.6	4.8	7.1	4.8	7.3	5.1	7.6	5.1	8.1	5.0	8.6	5.0
	32.5	6.4	4.7	6.5	4.8	7.0	4.8	7.2	5.1	7.5	5.0	8.0	5.0	8.5	4.9
	35.0	6.3	4.6	6.4	4.7	6.9	4.7	7.1	5.0	7.4	5.0	7.9	5.0	8.5	4.9
	37.5	6.2	4.6	6.3	4.7	6.8	4.7	7.1	5.0	7.3	5.0	7.8	4.9	8.4	4.9
	40.0	6.2	4.6	6.3	4.7	6.7	4.7	7.0	4.9	7.2	4.9	7.8	4.9	8.3	4.9
43.0	6.1	4.5	6.2	4.6	6.7	4.6	6.9	4.9	7.1	4.9	7.7	4.9	8.2	4.8	

kcal/h=kW x 860 , BTU/h = kW x 3,412

8. Cooling [Floor standing (Exposed 2-way/Exposed/Concealed type)]

8-4. Cooling capacity with PUHY-RP700-800YSJM

PFFY-P-VKM-E

CA:Capacity(kW) , SHC:Sensible Heat Capacity(kW)

Model size (Rated kW)	Outdoor air temp. °C D.B.	Indoor air temp.													
		21.5°C D.B. 15°C W.B.		23°C D.B. 16°C W.B.		25°C D.B. 18°C W.B.		27°C D.B. 19°C W.B.		28°C D.B. 20°C W.B.		30°C D.B. 22°C W.B.		32°C D.B. 24°C W.B.	
		CA	SHC	CA	SHC	CA	SHC	CA	SHC	CA	SHC	CA	SHC	CA	SHC
20 (2.2)	20.0	2.1	1.7	2.2	1.7	2.4	1.7	2.4	1.9	2.5	1.9	2.7	1.8	2.9	1.8
	22.5	2.1	1.7	2.2	1.7	2.3	1.7	2.4	1.8	2.5	1.8	2.6	1.8	2.8	1.8
	25.0	2.1	1.7	2.1	1.7	2.3	1.7	2.4	1.8	2.4	1.8	2.6	1.8	2.8	1.8
	27.5	2.0	1.6	2.1	1.7	2.2	1.7	2.3	1.8	2.4	1.8	2.6	1.8	2.7	1.8
	30.0	2.0	1.6	2.0	1.7	2.2	1.7	2.3	1.8	2.4	1.8	2.5	1.8	2.7	1.7
	32.5	1.9	1.6	2.0	1.7	2.2	1.7	2.2	1.8	2.3	1.8	2.5	1.7	2.6	1.7
	35.0	1.9	1.6	2.0	1.6	2.1	1.6	2.2	1.8	2.3	1.7	2.4	1.7	2.6	1.7
	37.5	1.9	1.6	1.9	1.6	2.1	1.6	2.1	1.7	2.2	1.7	2.4	1.7	2.5	1.7
	40.0	1.8	1.6	1.9	1.6	2.0	1.6	2.1	1.7	2.2	1.7	2.3	1.7	2.5	1.7
43.0	1.8	1.5	1.8	1.6	2.0	1.6	2.1	1.7	2.1	1.7	2.3	1.7	2.4	1.7	
25 (2.8)	20.0	2.7	2.0	2.8	2.1	3.0	2.1	3.1	2.2	3.2	2.2	3.4	2.2	3.7	2.1
	22.5	2.7	2.0	2.8	2.1	3.0	2.0	3.1	2.2	3.2	2.2	3.4	2.1	3.6	2.1
	25.0	2.6	2.0	2.7	2.0	2.9	2.0	3.0	2.1	3.1	2.1	3.3	2.1	3.5	2.1
	27.5	2.6	1.9	2.7	2.0	2.9	2.0	3.0	2.1	3.1	2.1	3.3	2.1	3.5	2.1
	30.0	2.5	1.9	2.6	2.0	2.8	2.0	2.9	2.1	3.0	2.1	3.2	2.1	3.4	2.0
	32.5	2.5	1.9	2.6	2.0	2.7	2.0	2.8	2.1	2.9	2.1	3.1	2.1	3.3	2.0
	35.0	2.4	1.9	2.5	1.9	2.7	1.9	2.8	2.1	2.9	2.0	3.1	2.0	3.3	2.0
	37.5	2.4	1.9	2.5	1.9	2.6	1.9	2.7	2.0	2.8	2.0	3.0	2.0	3.2	2.0
	40.0	2.3	1.8	2.4	1.9	2.6	1.9	2.7	2.0	2.8	2.0	3.0	2.0	3.1	2.0
43.0	2.3	1.8	2.4	1.9	2.5	1.9	2.6	2.0	2.7	2.0	2.9	2.0	3.1	1.9	
32 (3.6)	20.0	3.5	2.5	3.6	2.5	3.9	2.5	4.0	2.7	4.1	2.6	4.4	2.6	4.7	2.6
	22.5	3.4	2.4	3.5	2.5	3.8	2.5	3.9	2.6	4.1	2.6	4.3	2.6	4.6	2.6
	25.0	3.4	2.4	3.5	2.5	3.7	2.5	3.9	2.6	4.0	2.6	4.3	2.6	4.5	2.5
	27.5	3.3	2.4	3.4	2.4	3.7	2.4	3.8	2.6	3.9	2.6	4.2	2.5	4.5	2.5
	30.0	3.2	2.3	3.4	2.4	3.6	2.4	3.7	2.5	3.9	2.5	4.1	2.5	4.4	2.5
	32.5	3.2	2.3	3.3	2.4	3.5	2.4	3.7	2.5	3.8	2.5	4.0	2.5	4.3	2.4
	35.0	3.1	2.3	3.2	2.3	3.5	2.3	3.6	2.5	3.7	2.5	4.0	2.4	4.2	2.4
	37.5	3.1	2.2	3.2	2.3	3.4	2.3	3.5	2.4	3.6	2.4	3.9	2.4	4.1	2.4
	40.0	3.0	2.2	3.1	2.3	3.3	2.3	3.4	2.4	3.6	2.4	3.8	2.4	4.0	2.3
43.0	2.9	2.2	3.0	2.2	3.2	2.2	3.4	2.4	3.5	2.4	3.7	2.3	3.9	2.3	
40 (4.5)	20.0	4.3	3.0	4.5	3.1	4.8	3.1	5.0	3.3	5.2	3.3	5.5	3.2	5.9	3.2
	22.5	4.3	3.0	4.4	3.1	4.7	3.1	4.9	3.2	5.1	3.2	5.4	3.2	5.8	3.2
	25.0	4.2	3.0	4.3	3.0	4.7	3.0	4.8	3.2	5.0	3.2	5.3	3.2	5.7	3.1
	27.5	4.1	2.9	4.3	3.0	4.6	3.0	4.7	3.2	4.9	3.1	5.2	3.1	5.6	3.1
	30.0	4.1	2.9	4.2	3.0	4.5	3.0	4.7	3.1	4.8	3.1	5.1	3.1	5.5	3.0
	32.5	4.0	2.8	4.1	2.9	4.4	2.9	4.6	3.1	4.7	3.1	5.0	3.0	5.4	3.0
	35.0	3.9	2.8	4.0	2.9	4.3	2.9	4.5	3.0	4.6	3.0	4.9	3.0	5.3	3.0
	37.5	3.8	2.8	4.0	2.8	4.2	2.8	4.4	3.0	4.5	3.0	4.8	3.0	5.2	2.9
	40.0	3.8	2.7	3.9	2.8	4.2	2.8	4.3	3.0	4.5	2.9	4.8	2.9	5.1	2.9
43.0	3.7	2.7	3.8	2.8	4.1	2.7	4.2	2.9	4.3	2.9	4.6	2.9	4.9	2.8	

kcal/h=kW x 860 , BTU/h = kW x 3,412

8. Cooling [Floor standing (Exposed 2-way/Exposed/Concealed type)]

PFFY-P-VLEM-E,VLRM-E

CA:Capacity(kW) , SHC:Sensible Heat Capacity(kW)

Model size (Rated kW)	Outdoor air temp. °C D.B.	Indoor air temp.													
		21.5°C D.B. 15°C W.B.		23°C D.B. 16°C W.B.		25°C D.B. 18°C W.B.		27°C D.B. 19°C W.B.		28°C D.B. 20°C W.B.		30°C D.B. 22°C W.B.		32°C D.B. 24°C W.B.	
		CA	SHC	CA	SHC	CA	SHC	CA	SHC	CA	SHC	CA	SHC	CA	SHC
20 (2.2)	20.0	2.1	1.7	2.2	1.7	2.4	1.7	2.4	1.8	2.5	1.8	2.7	1.8	2.9	1.8
	22.5	2.1	1.7	2.2	1.7	2.3	1.7	2.4	1.8	2.5	1.8	2.6	1.8	2.8	1.8
	25.0	2.1	1.6	2.1	1.7	2.3	1.7	2.4	1.8	2.4	1.8	2.6	1.8	2.8	1.8
	27.5	2.0	1.6	2.1	1.7	2.2	1.7	2.3	1.8	2.4	1.8	2.6	1.8	2.7	1.7
	30.0	2.0	1.6	2.0	1.7	2.2	1.7	2.3	1.8	2.4	1.8	2.5	1.8	2.7	1.7
	32.5	1.9	1.6	2.0	1.6	2.2	1.6	2.2	1.8	2.3	1.8	2.5	1.7	2.6	1.7
	35.0	1.9	1.6	2.0	1.6	2.1	1.6	2.2	1.7	2.3	1.7	2.4	1.7	2.6	1.7
	37.5	1.9	1.6	1.9	1.6	2.1	1.6	2.1	1.7	2.2	1.7	2.4	1.7	2.5	1.7
	40.0	1.8	1.5	1.9	1.6	2.0	1.6	2.1	1.7	2.2	1.7	2.3	1.7	2.5	1.7
43.0	1.8	1.5	1.8	1.6	2.0	1.6	2.1	1.7	2.1	1.7	2.3	1.7	2.4	1.6	
25 (2.8)	20.0	2.7	2.0	2.8	2.0	3.0	2.0	3.1	2.1	3.2	2.1	3.4	2.1	3.7	2.1
	22.5	2.7	1.9	2.8	2.0	3.0	2.0	3.1	2.1	3.2	2.1	3.4	2.1	3.6	2.1
	25.0	2.6	1.9	2.7	2.0	2.9	2.0	3.0	2.1	3.1	2.1	3.3	2.1	3.5	2.0
	27.5	2.6	1.9	2.7	2.0	2.9	1.9	3.0	2.1	3.1	2.1	3.3	2.0	3.5	2.0
	30.0	2.5	1.9	2.6	1.9	2.8	1.9	2.9	2.0	3.0	2.0	3.2	2.0	3.4	2.0
	32.5	2.5	1.8	2.6	1.9	2.7	1.9	2.8	2.0	2.9	2.0	3.1	2.0	3.3	2.0
	35.0	2.4	1.8	2.5	1.9	2.7	1.9	2.8	2.0	2.9	2.0	3.1	2.0	3.3	1.9
	37.5	2.4	1.8	2.5	1.9	2.6	1.9	2.7	2.0	2.8	2.0	3.0	1.9	3.2	1.9
	40.0	2.3	1.8	2.4	1.8	2.6	1.8	2.7	1.9	2.8	1.9	3.0	1.9	3.1	1.9
43.0	2.3	1.8	2.4	1.8	2.5	1.8	2.6	1.9	2.7	1.9	2.9	1.9	3.1	1.9	
32 (3.6)	20.0	3.5	2.5	3.6	2.6	3.9	2.6	4.0	2.7	4.1	2.7	4.4	2.7	4.7	2.7
	22.5	3.4	2.5	3.5	2.6	3.8	2.5	3.9	2.7	4.1	2.7	4.3	2.7	4.6	2.6
	25.0	3.4	2.4	3.5	2.5	3.7	2.5	3.9	2.7	4.0	2.7	4.3	2.6	4.5	2.6
	27.5	3.3	2.4	3.4	2.5	3.7	2.5	3.8	2.6	3.9	2.6	4.2	2.6	4.5	2.6
	30.0	3.2	2.4	3.4	2.5	3.6	2.5	3.7	2.6	3.9	2.6	4.1	2.6	4.4	2.5
	32.5	3.2	2.4	3.3	2.4	3.5	2.4	3.7	2.6	3.8	2.6	4.0	2.5	4.3	2.5
	35.0	3.1	2.3	3.2	2.4	3.5	2.4	3.6	2.5	3.7	2.5	4.0	2.5	4.2	2.5
	37.5	3.1	2.3	3.2	2.4	3.4	2.4	3.5	2.5	3.6	2.5	3.9	2.5	4.1	2.4
	40.0	3.0	2.3	3.1	2.3	3.3	2.3	3.4	2.5	3.6	2.5	3.8	2.4	4.0	2.4
43.0	2.9	2.2	3.0	2.3	3.2	2.3	3.4	2.4	3.5	2.4	3.7	2.4	3.9	2.4	
40 (4.5)	20.0	4.3	3.1	4.5	3.2	4.8	3.2	5.0	3.4	5.2	3.4	5.5	3.4	5.9	3.3
	22.5	4.3	3.1	4.4	3.2	4.7	3.2	4.9	3.4	5.1	3.4	5.4	3.3	5.8	3.3
	25.0	4.2	3.1	4.3	3.2	4.7	3.2	4.8	3.3	5.0	3.3	5.3	3.3	5.7	3.3
	27.5	4.1	3.0	4.3	3.1	4.6	3.1	4.7	3.3	4.9	3.3	5.2	3.3	5.6	3.2
	30.0	4.1	3.0	4.2	3.1	4.5	3.1	4.7	3.3	4.8	3.3	5.1	3.2	5.5	3.2
	32.5	4.0	3.0	4.1	3.1	4.4	3.0	4.6	3.2	4.7	3.2	5.0	3.2	5.4	3.1
	35.0	3.9	2.9	4.0	3.0	4.3	3.0	4.5	3.2	4.6	3.2	4.9	3.2	5.3	3.1
	37.5	3.8	2.9	4.0	3.0	4.2	3.0	4.4	3.2	4.5	3.1	4.8	3.1	5.2	3.1
	40.0	3.8	2.9	3.9	2.9	4.2	2.9	4.3	3.1	4.5	3.1	4.8	3.1	5.1	3.0
43.0	3.7	2.8	3.8	2.9	4.1	2.9	4.2	3.1	4.3	3.1	4.6	3.0	4.9	3.0	
50 (5.6)	20.0	5.4	4.0	5.6	4.1	6.0	4.1	6.2	4.3	6.4	4.3	6.9	4.3	7.3	4.2
	22.5	5.3	3.9	5.5	4.1	5.9	4.0	6.1	4.3	6.3	4.3	6.7	4.2	7.2	4.2
	25.0	5.2	3.9	5.4	4.0	5.8	4.0	6.0	4.2	6.2	4.2	6.6	4.2	7.0	4.1
	27.5	5.1	3.8	5.3	4.0	5.7	3.9	5.9	4.2	6.1	4.2	6.5	4.1	6.9	4.1
	30.0	5.0	3.8	5.2	3.9	5.6	3.9	5.8	4.1	6.0	4.1	6.4	4.1	6.8	4.0
	32.5	5.0	3.7	5.1	3.9	5.5	3.9	5.7	4.1	5.9	4.1	6.3	4.0	6.7	4.0
	35.0	4.9	3.7	5.0	3.8	5.4	3.8	5.6	4.1	5.8	4.0	6.2	4.0	6.5	3.9
	37.5	4.8	3.7	4.9	3.8	5.3	3.8	5.5	4.0	5.7	4.0	6.0	3.9	6.4	3.9
	40.0	4.7	3.6	4.8	3.7	5.2	3.7	5.4	4.0	5.5	3.9	5.9	3.9	6.3	3.9
43.0	4.6	3.6	4.7	3.7	5.1	3.7	5.2	3.9	5.4	3.9	5.8	3.9	6.1	3.8	
63 (7.1)	20.0	6.9	4.9	7.1	5.1	7.6	5.1	7.9	5.3	8.2	5.3	8.7	5.3	9.3	5.2
	22.5	6.7	4.9	7.0	5.0	7.5	5.0	7.8	5.3	8.0	5.3	8.6	5.2	9.1	5.1
	25.0	6.6	4.8	6.9	5.0	7.4	4.9	7.6	5.2	7.9	5.2	8.4	5.2	8.9	5.1
	27.5	6.5	4.7	6.7	4.9	7.2	4.9	7.5	5.2	7.7	5.1	8.3	5.1	8.8	5.0
	30.0	6.4	4.7	6.6	4.8	7.1	4.8	7.3	5.1	7.6	5.1	8.1	5.0	8.6	5.0
	32.5	6.3	4.6	6.5	4.8	7.0	4.8	7.2	5.0	7.5	5.0	7.9	5.0	8.5	4.9
	35.0	6.2	4.6	6.4	4.7	6.8	4.7	7.1	5.0	7.3	5.0	7.8	4.9	8.3	4.8
	37.5	6.1	4.5	6.2	4.6	6.7	4.6	6.9	4.9	7.2	4.9	7.6	4.9	8.1	4.8
	40.0	5.9	4.5	6.1	4.6	6.6	4.6	6.8	4.9	7.0	4.8	7.5	4.8	8.0	4.7
43.0	5.8	4.4	6.0	4.5	6.4	4.5	6.6	4.8	6.9	4.8	7.3	4.7	7.8	4.7	

kcal/h=kW x 860 , BTU/h = kW x 3,412

8. Cooling [Floor standing (Exposed 2-way/Exposed/Concealed type)]

PFFY-P-VLRMM-E

CA:Capacity(kW) , SHC:Sensible Heat Capacity(kW)

Model size (Rated kW)	Outdoor air temp. °C D.B.	Indoor air temp.													
		21.5°C D.B. 15°C W.B.		23°C D.B. 16°C W.B.		25°C D.B. 18°C W.B.		27°C D.B. 19°C W.B.		28°C D.B. 20°C W.B.		30°C D.B. 22°C W.B.		32°C D.B. 24°C W.B.	
		CA	SHC	CA	SHC	CA	SHC	CA	SHC	CA	SHC	CA	SHC	CA	SHC
20 (2.2)	20.0	2.1	1.7	2.2	1.7	2.4	1.7	2.4	1.8	2.5	1.8	2.7	1.8	2.9	1.8
	22.5	2.1	1.7	2.2	1.7	2.3	1.7	2.4	1.8	2.5	1.8	2.6	1.8	2.8	1.8
	25.0	2.1	1.6	2.1	1.7	2.3	1.7	2.4	1.8	2.4	1.8	2.6	1.8	2.8	1.8
	27.5	2.0	1.6	2.1	1.7	2.2	1.7	2.3	1.8	2.4	1.8	2.6	1.8	2.7	1.7
	30.0	2.0	1.6	2.0	1.7	2.2	1.7	2.3	1.8	2.4	1.8	2.5	1.8	2.7	1.7
	32.5	1.9	1.6	2.0	1.6	2.2	1.6	2.2	1.8	2.3	1.8	2.5	1.7	2.6	1.7
	35.0	1.9	1.6	2.0	1.6	2.1	1.6	2.2	1.7	2.3	1.7	2.4	1.7	2.6	1.7
	37.5	1.9	1.6	1.9	1.6	2.1	1.6	2.1	1.7	2.2	1.7	2.4	1.7	2.5	1.7
	40.0	1.8	1.5	1.9	1.6	2.0	1.6	2.1	1.7	2.2	1.7	2.3	1.7	2.5	1.7
43.0	1.8	1.5	1.8	1.6	2.0	1.6	2.1	1.7	2.1	1.7	2.3	1.7	2.4	1.6	
25 (2.8)	20.0	2.7	2.0	2.8	2.0	3.0	2.0	3.1	2.1	3.2	2.1	3.4	2.1	3.7	2.1
	22.5	2.7	1.9	2.8	2.0	3.0	2.0	3.1	2.1	3.2	2.1	3.4	2.1	3.6	2.1
	25.0	2.6	1.9	2.7	2.0	2.9	2.0	3.0	2.1	3.1	2.1	3.3	2.1	3.5	2.0
	27.5	2.6	1.9	2.7	2.0	2.9	1.9	3.0	2.1	3.1	2.1	3.3	2.0	3.5	2.0
	30.0	2.5	1.9	2.6	1.9	2.8	1.9	2.9	2.0	3.0	2.0	3.2	2.0	3.4	2.0
	32.5	2.5	1.8	2.6	1.9	2.7	1.9	2.8	2.0	2.9	2.0	3.1	2.0	3.3	2.0
	35.0	2.4	1.8	2.5	1.9	2.7	1.9	2.8	2.0	2.9	2.0	3.1	2.0	3.3	1.9
	37.5	2.4	1.8	2.5	1.9	2.6	1.9	2.7	2.0	2.8	2.0	3.0	1.9	3.2	1.9
	40.0	2.3	1.8	2.4	1.8	2.6	1.8	2.7	1.9	2.8	1.9	3.0	1.9	3.1	1.9
43.0	2.3	1.8	2.4	1.8	2.5	1.8	2.6	1.9	2.7	1.9	2.9	1.9	3.1	1.9	
32 (3.6)	20.0	3.5	2.5	3.6	2.6	3.9	2.6	4.0	2.7	4.1	2.7	4.4	2.7	4.7	2.7
	22.5	3.4	2.5	3.5	2.6	3.8	2.5	3.9	2.7	4.1	2.7	4.3	2.7	4.6	2.6
	25.0	3.4	2.4	3.5	2.5	3.7	2.5	3.9	2.7	4.0	2.7	4.3	2.6	4.5	2.6
	27.5	3.3	2.4	3.4	2.5	3.7	2.5	3.8	2.6	3.9	2.6	4.2	2.6	4.5	2.6
	30.0	3.2	2.4	3.4	2.5	3.6	2.5	3.7	2.6	3.9	2.6	4.1	2.6	4.4	2.5
	32.5	3.2	2.4	3.3	2.4	3.5	2.4	3.7	2.6	3.8	2.6	4.0	2.5	4.3	2.5
	35.0	3.1	2.3	3.2	2.4	3.5	2.4	3.6	2.5	3.7	2.5	4.0	2.5	4.2	2.5
	37.5	3.1	2.3	3.2	2.4	3.4	2.4	3.5	2.5	3.6	2.5	3.9	2.5	4.1	2.4
	40.0	3.0	2.3	3.1	2.3	3.3	2.3	3.4	2.5	3.6	2.5	3.8	2.4	4.0	2.4
43.0	2.9	2.2	3.0	2.3	3.2	2.3	3.4	2.4	3.5	2.4	3.7	2.4	3.9	2.4	
40 (4.5)	20.0	4.3	3.1	4.5	3.2	4.8	3.2	5.0	3.4	5.2	3.4	5.5	3.4	5.9	3.3
	22.5	4.3	3.1	4.4	3.2	4.7	3.2	4.9	3.4	5.1	3.4	5.4	3.3	5.8	3.3
	25.0	4.2	3.1	4.3	3.2	4.7	3.2	4.8	3.3	5.0	3.3	5.3	3.3	5.7	3.3
	27.5	4.1	3.0	4.3	3.1	4.6	3.1	4.7	3.3	4.9	3.3	5.2	3.3	5.6	3.2
	30.0	4.1	3.0	4.2	3.1	4.5	3.1	4.7	3.3	4.8	3.3	5.1	3.2	5.5	3.2
	32.5	4.0	3.0	4.1	3.1	4.4	3.0	4.6	3.2	4.7	3.2	5.0	3.2	5.4	3.1
	35.0	3.9	2.9	4.0	3.0	4.3	3.0	4.5	3.2	4.6	3.2	4.9	3.2	5.3	3.1
	37.5	3.8	2.9	4.0	3.0	4.2	3.0	4.4	3.2	4.5	3.1	4.8	3.1	5.2	3.1
	40.0	3.8	2.9	3.9	2.9	4.2	2.9	4.3	3.1	4.5	3.1	4.8	3.1	5.1	3.0
43.0	3.7	2.8	3.8	2.9	4.1	2.9	4.2	3.1	4.3	3.1	4.6	3.0	4.9	3.0	
50 (5.6)	20.0	5.4	4.0	5.6	4.1	6.0	4.1	6.2	4.3	6.4	4.3	6.9	4.3	7.3	4.2
	22.5	5.3	3.9	5.5	4.1	5.9	4.0	6.1	4.3	6.3	4.3	6.7	4.2	7.2	4.2
	25.0	5.2	3.9	5.4	4.0	5.8	4.0	6.0	4.2	6.2	4.2	6.6	4.2	7.0	4.1
	27.5	5.1	3.8	5.3	4.0	5.7	3.9	5.9	4.2	6.1	4.2	6.5	4.1	6.9	4.1
	30.0	5.0	3.8	5.2	3.9	5.6	3.9	5.8	4.1	6.0	4.1	6.4	4.1	6.8	4.0
	32.5	5.0	3.7	5.1	3.9	5.5	3.9	5.7	4.1	5.9	4.1	6.3	4.0	6.7	4.0
	35.0	4.9	3.7	5.0	3.8	5.4	3.8	5.6	4.1	5.8	4.0	6.2	4.0	6.5	3.9
	37.5	4.8	3.7	4.9	3.8	5.3	3.8	5.5	4.0	5.7	4.0	6.0	3.9	6.4	3.9
	40.0	4.7	3.6	4.8	3.7	5.2	3.7	5.4	4.0	5.5	3.9	5.9	3.9	6.3	3.9
43.0	4.6	3.6	4.7	3.7	5.1	3.7	5.2	3.9	5.4	3.9	5.8	3.9	6.1	3.8	
63 (7.1)	20.0	6.9	4.9	7.1	5.1	7.6	5.1	7.9	5.3	8.2	5.3	8.7	5.3	9.3	5.2
	22.5	6.7	4.9	7.0	5.0	7.5	5.0	7.8	5.3	8.0	5.3	8.6	5.2	9.1	5.1
	25.0	6.6	4.8	6.9	5.0	7.4	4.9	7.6	5.2	7.9	5.2	8.4	5.2	8.9	5.1
	27.5	6.5	4.7	6.7	4.9	7.2	4.9	7.5	5.2	7.7	5.1	8.3	5.1	8.8	5.0
	30.0	6.4	4.7	6.6	4.8	7.1	4.8	7.3	5.1	7.6	5.1	8.1	5.0	8.6	5.0
	32.5	6.3	4.6	6.5	4.8	7.0	4.8	7.2	5.0	7.5	5.0	7.9	5.0	8.5	4.9
	35.0	6.2	4.6	6.4	4.7	6.8	4.7	7.1	5.0	7.3	5.0	7.8	4.9	8.3	4.8
	37.5	6.1	4.5	6.2	4.6	6.7	4.6	6.9	4.9	7.2	4.9	7.6	4.9	8.1	4.8
	40.0	5.9	4.5	6.1	4.6	6.6	4.6	6.8	4.9	7.0	4.8	7.5	4.8	8.0	4.7
43.0	5.8	4.4	6.0	4.5	6.4	4.5	6.6	4.8	6.9	4.8	7.3	4.7	7.8	4.7	

kcal/h=kW x 860 , BTU/h = kW x 3,412

8. Cooling [Floor standing (Exposed 2-way/Exposed/Concealed type)]

8-5. Cooling capacity with PUHY-RP850-900YSJM

PFFY-P-VKM-E

CA:Capacity(kW) , SHC:Sensible Heat Capacity(kW)

Model size (Rated kW)	Outdoor air temp. °C D.B.	Indoor air temp.													
		21.5°C D.B. 15°C W.B.		23°C D.B. 16°C W.B.		25°C D.B. 18°C W.B.		27°C D.B. 19°C W.B.		28°C D.B. 20°C W.B.		30°C D.B. 22°C W.B.		32°C D.B. 24°C W.B.	
		CA	SHC	CA	SHC	CA	SHC	CA	SHC	CA	SHC	CA	SHC	CA	SHC
20 (2.2)	20.0	2.1	1.7	2.1	1.7	2.3	1.7	2.4	1.8	2.4	1.8	2.6	1.8	2.8	1.8
	22.5	2.1	1.7	2.1	1.7	2.3	1.7	2.3	1.8	2.4	1.8	2.6	1.8	2.7	1.8
	25.0	2.0	1.6	2.1	1.7	2.2	1.7	2.3	1.8	2.4	1.8	2.5	1.8	2.7	1.8
	27.5	2.0	1.6	2.1	1.7	2.2	1.7	2.3	1.8	2.4	1.8	2.5	1.8	2.7	1.8
	30.0	2.0	1.6	2.0	1.7	2.2	1.7	2.3	1.8	2.3	1.8	2.5	1.8	2.7	1.7
	32.5	2.0	1.6	2.0	1.7	2.2	1.7	2.2	1.8	2.3	1.8	2.5	1.8	2.6	1.7
	35.0	2.0	1.6	2.0	1.7	2.1	1.6	2.2	1.8	2.3	1.8	2.5	1.7	2.6	1.7
	37.5	1.9	1.6	2.0	1.6	2.1	1.6	2.2	1.8	2.3	1.8	2.4	1.7	2.6	1.7
	40.0	1.9	1.6	1.9	1.6	2.1	1.6	2.2	1.7	2.2	1.7	2.4	1.7	2.6	1.7
43.0	1.9	1.6	1.9	1.6	2.1	1.6	2.1	1.7	2.2	1.7	2.4	1.7	2.5	1.7	
25 (2.8)	20.0	2.6	2.0	2.7	2.0	2.9	2.0	3.0	2.2	3.1	2.1	3.3	2.1	3.5	2.1
	22.5	2.6	2.0	2.7	2.0	2.9	2.0	3.0	2.1	3.1	2.1	3.3	2.1	3.5	2.1
	25.0	2.6	2.0	2.7	2.0	2.9	2.0	2.9	2.1	3.0	2.1	3.2	2.1	3.5	2.1
	27.5	2.6	1.9	2.6	2.0	2.8	2.0	2.9	2.1	3.0	2.1	3.2	2.1	3.4	2.1
	30.0	2.5	1.9	2.6	2.0	2.8	2.0	2.9	2.1	3.0	2.1	3.2	2.1	3.4	2.0
	32.5	2.5	1.9	2.6	2.0	2.8	2.0	2.9	2.1	3.0	2.1	3.2	2.1	3.4	2.0
	35.0	2.5	1.9	2.5	1.9	2.7	1.9	2.8	2.1	2.9	2.1	3.1	2.0	3.3	2.0
	37.5	2.5	1.9	2.5	1.9	2.7	1.9	2.8	2.1	2.9	2.1	3.1	2.0	3.3	2.0
	40.0	2.4	1.9	2.5	1.9	2.7	1.9	2.8	2.0	2.9	2.0	3.1	2.0	3.3	2.0
43.0	2.4	1.9	2.4	1.9	2.6	1.9	2.7	2.0	2.8	2.0	3.0	2.0	3.2	2.0	
32 (3.6)	20.0	3.4	2.4	3.5	2.5	3.7	2.5	3.9	2.6	4.0	2.6	4.3	2.6	4.5	2.5
	22.5	3.4	2.4	3.5	2.5	3.7	2.4	3.8	2.6	4.0	2.6	4.2	2.5	4.5	2.5
	25.0	3.3	2.4	3.4	2.4	3.7	2.4	3.8	2.6	3.9	2.5	4.2	2.5	4.4	2.5
	27.5	3.3	2.4	3.4	2.4	3.6	2.4	3.8	2.5	3.9	2.5	4.1	2.5	4.4	2.5
	30.0	3.3	2.3	3.3	2.4	3.6	2.4	3.7	2.5	3.8	2.5	4.1	2.5	4.4	2.5
	32.5	3.2	2.3	3.3	2.4	3.5	2.4	3.7	2.5	3.8	2.5	4.1	2.5	4.3	2.4
	35.0	3.2	2.3	3.3	2.4	3.5	2.3	3.6	2.5	3.8	2.5	4.0	2.5	4.3	2.4
	37.5	3.2	2.3	3.2	2.3	3.5	2.3	3.6	2.5	3.7	2.5	4.0	2.4	4.2	2.4
	40.0	3.1	2.3	3.2	2.3	3.4	2.3	3.5	2.4	3.7	2.4	3.9	2.4	4.2	2.4
43.0	3.1	2.3	3.1	2.3	3.4	2.3	3.5	2.4	3.6	2.4	3.9	2.4	4.2	2.4	
40 (4.5)	20.0	4.3	3.0	4.4	3.1	4.7	3.0	4.8	3.2	5.0	3.2	5.3	3.2	5.7	3.1
	22.5	4.2	3.0	4.3	3.0	4.6	3.0	4.8	3.2	4.9	3.2	5.3	3.1	5.6	3.1
	25.0	4.2	2.9	4.3	3.0	4.6	3.0	4.7	3.2	4.9	3.1	5.2	3.1	5.6	3.1
	27.5	4.1	2.9	4.2	3.0	4.5	3.0	4.7	3.1	4.8	3.1	5.2	3.1	5.5	3.1
	30.0	4.1	2.9	4.2	2.9	4.5	2.9	4.6	3.1	4.8	3.1	5.1	3.1	5.5	3.0
	32.5	4.0	2.9	4.1	2.9	4.4	2.9	4.6	3.1	4.7	3.1	5.1	3.0	5.4	3.0
	35.0	4.0	2.8	4.1	2.9	4.4	2.9	4.5	3.0	4.7	3.0	5.0	3.0	5.4	3.0
	37.5	4.0	2.8	4.0	2.9	4.3	2.9	4.5	3.0	4.6	3.0	5.0	3.0	5.3	3.0
	40.0	3.9	2.8	4.0	2.8	4.3	2.8	4.4	3.0	4.6	3.0	4.9	3.0	5.3	3.0
43.0	3.9	2.8	3.9	2.8	4.2	2.8	4.4	3.0	4.5	3.0	4.9	3.0	5.2	2.9	

kcal/h=kW x 860 , BTU/h = kW x 3,412

8. Cooling [Floor standing (Exposed 2-way/Exposed/Concealed type)]

PFFY-P-VLEM-E,VLRM-E

CA:Capacity(kW) , SHC:Sensible Heat Capacity(kW)

Model size (Rated kW)	Outdoor air temp. °C D.B.	Indoor air temp.													
		21.5°C D.B. 15°C W.B.		23°C D.B. 16°C W.B.		25°C D.B. 18°C W.B.		27°C D.B. 19°C W.B.		28°C D.B. 20°C W.B.		30°C D.B. 22°C W.B.		32°C D.B. 24°C W.B.	
		CA	SHC	CA	SHC	CA	SHC	CA	SHC	CA	SHC	CA	SHC	CA	SHC
20 (2.2)	20.0	2.1	1.7	2.1	1.7	2.3	1.7	2.4	1.8	2.4	1.8	2.6	1.8	2.8	1.8
	22.5	2.1	1.6	2.1	1.7	2.3	1.7	2.3	1.8	2.4	1.8	2.6	1.8	2.7	1.8
	25.0	2.0	1.6	2.1	1.7	2.2	1.7	2.3	1.8	2.4	1.8	2.5	1.8	2.7	1.7
	27.5	2.0	1.6	2.1	1.7	2.2	1.7	2.3	1.8	2.4	1.8	2.5	1.8	2.7	1.7
	30.0	2.0	1.6	2.0	1.7	2.2	1.7	2.3	1.8	2.3	1.8	2.5	1.7	2.7	1.7
	32.5	2.0	1.6	2.0	1.7	2.2	1.6	2.2	1.8	2.3	1.8	2.5	1.7	2.6	1.7
	35.0	2.0	1.6	2.0	1.6	2.1	1.6	2.2	1.7	2.3	1.7	2.5	1.7	2.6	1.7
	37.5	1.9	1.6	2.0	1.6	2.1	1.6	2.2	1.7	2.3	1.7	2.4	1.7	2.6	1.7
	40.0	1.9	1.6	1.9	1.6	2.1	1.6	2.2	1.7	2.2	1.7	2.4	1.7	2.6	1.7
43.0	1.9	1.6	1.9	1.6	2.1	1.6	2.1	1.7	2.2	1.7	2.4	1.7	2.5	1.7	
25 (2.8)	20.0	2.6	1.9	2.7	2.0	2.9	2.0	3.0	2.1	3.1	2.1	3.3	2.1	3.5	2.0
	22.5	2.6	1.9	2.7	2.0	2.9	2.0	3.0	2.1	3.1	2.1	3.3	2.0	3.5	2.0
	25.0	2.6	1.9	2.7	2.0	2.9	1.9	2.9	2.1	3.0	2.1	3.2	2.0	3.5	2.0
	27.5	2.6	1.9	2.6	1.9	2.8	1.9	2.9	2.0	3.0	2.0	3.2	2.0	3.4	2.0
	30.0	2.5	1.9	2.6	1.9	2.8	1.9	2.9	2.0	3.0	2.0	3.2	2.0	3.4	2.0
	32.5	2.5	1.9	2.6	1.9	2.8	1.9	2.9	2.0	3.0	2.0	3.2	2.0	3.4	2.0
	35.0	2.5	1.9	2.5	1.9	2.7	1.9	2.8	2.0	2.9	2.0	3.1	2.0	3.3	2.0
	37.5	2.5	1.8	2.5	1.9	2.7	1.9	2.8	2.0	2.9	2.0	3.1	2.0	3.3	2.0
	40.0	2.4	1.8	2.5	1.9	2.7	1.9	2.8	2.0	2.9	2.0	3.1	2.0	3.3	1.9
43.0	2.4	1.8	2.4	1.8	2.6	1.8	2.7	2.0	2.8	2.0	3.0	1.9	3.2	1.9	
32 (3.6)	20.0	3.4	2.5	3.5	2.5	3.7	2.5	3.9	2.7	4.0	2.7	4.3	2.6	4.5	2.6
	22.5	3.4	2.5	3.5	2.5	3.7	2.5	3.8	2.6	4.0	2.6	4.2	2.6	4.5	2.6
	25.0	3.3	2.4	3.4	2.5	3.7	2.5	3.8	2.6	3.9	2.6	4.2	2.6	4.4	2.6
	27.5	3.3	2.4	3.4	2.5	3.6	2.5	3.8	2.6	3.9	2.6	4.1	2.6	4.4	2.5
	30.0	3.3	2.4	3.3	2.5	3.6	2.4	3.7	2.6	3.8	2.6	4.1	2.6	4.4	2.5
	32.5	3.2	2.4	3.3	2.4	3.5	2.4	3.7	2.6	3.8	2.6	4.1	2.5	4.3	2.5
	35.0	3.2	2.4	3.3	2.4	3.5	2.4	3.6	2.5	3.8	2.6	4.0	2.5	4.3	2.5
	37.5	3.2	2.3	3.2	2.4	3.5	2.4	3.6	2.5	3.7	2.5	4.0	2.5	4.2	2.5
	40.0	3.1	2.3	3.2	2.4	3.4	2.4	3.5	2.5	3.7	2.5	3.9	2.5	4.2	2.5
43.0	3.1	2.3	3.1	2.4	3.4	2.4	3.5	2.5	3.6	2.5	3.9	2.5	4.2	2.5	
40 (4.5)	20.0	4.3	3.1	4.4	3.2	4.7	3.2	4.8	3.4	5.0	3.3	5.3	3.3	5.7	3.3
	22.5	4.2	3.1	4.3	3.2	4.6	3.1	4.8	3.3	4.9	3.3	5.3	3.3	5.6	3.2
	25.0	4.2	3.1	4.3	3.1	4.6	3.1	4.7	3.3	4.9	3.3	5.2	3.3	5.6	3.2
	27.5	4.1	3.0	4.2	3.1	4.5	3.1	4.7	3.3	4.8	3.3	5.2	3.2	5.5	3.2
	30.0	4.1	3.0	4.2	3.1	4.5	3.1	4.6	3.3	4.8	3.2	5.1	3.2	5.5	3.2
	32.5	4.0	3.0	4.1	3.1	4.4	3.1	4.6	3.2	4.7	3.2	5.1	3.2	5.4	3.2
	35.0	4.0	3.0	4.1	3.0	4.4	3.0	4.5	3.2	4.7	3.2	5.0	3.2	5.4	3.1
	37.5	4.0	3.0	4.0	3.0	4.3	3.0	4.5	3.2	4.6	3.2	5.0	3.2	5.3	3.1
	40.0	3.9	2.9	4.0	3.0	4.3	3.0	4.4	3.2	4.6	3.2	4.9	3.1	5.3	3.1
43.0	3.9	2.9	3.9	3.0	4.2	3.0	4.4	3.1	4.5	3.1	4.9	3.1	5.2	3.1	
50 (5.6)	20.0	5.3	3.9	5.5	4.0	5.8	4.0	6.0	4.2	6.2	4.2	6.6	4.2	7.0	4.1
	22.5	5.2	3.9	5.4	4.0	5.8	4.0	6.0	4.2	6.2	4.2	6.6	4.2	7.0	4.1
	25.0	5.2	3.9	5.3	4.0	5.7	3.9	5.9	4.2	6.1	4.2	6.5	4.1	6.9	4.1
	27.5	5.1	3.8	5.3	3.9	5.6	3.9	5.8	4.2	6.0	4.1	6.4	4.1	6.9	4.1
	30.0	5.1	3.8	5.2	3.9	5.6	3.9	5.8	4.1	6.0	4.1	6.4	4.1	6.8	4.0
	32.5	5.0	3.8	5.1	3.9	5.5	3.9	5.7	4.1	5.9	4.1	6.3	4.1	6.7	4.0
	35.0	5.0	3.8	5.1	3.8	5.4	3.8	5.6	4.1	5.8	4.1	6.2	4.0	6.7	4.0
	37.5	4.9	3.7	5.0	3.8	5.4	3.8	5.6	4.1	5.8	4.0	6.2	4.0	6.6	4.0
	40.0	4.9	3.7	4.9	3.8	5.3	3.8	5.5	4.0	5.7	4.0	6.1	4.0	6.5	3.9
43.0	4.8	3.7	4.9	3.7	5.2	3.7	5.4	4.0	5.6	4.0	6.0	4.0	6.5	3.9	
63 (7.1)	20.0	6.7	4.8	6.9	5.0	7.4	5.0	7.6	5.2	7.9	5.2	8.4	5.1	8.9	5.1
	22.5	6.6	4.8	6.8	4.9	7.3	4.9	7.6	5.2	7.8	5.2	8.3	5.1	8.8	5.0
	25.0	6.6	4.8	6.8	4.9	7.2	4.9	7.5	5.2	7.7	5.1	8.2	5.1	8.8	5.0
	27.5	6.5	4.7	6.7	4.9	7.2	4.8	7.4	5.1	7.6	5.1	8.2	5.1	8.7	5.0
	30.0	6.4	4.7	6.6	4.8	7.1	4.8	7.3	5.1	7.6	5.1	8.1	5.0	8.6	5.0
	32.5	6.4	4.7	6.5	4.8	7.0	4.8	7.2	5.1	7.5	5.0	8.0	5.0	8.5	4.9
	35.0	6.3	4.6	6.4	4.7	6.9	4.7	7.1	5.0	7.4	5.0	7.9	5.0	8.5	4.9
	37.5	6.2	4.6	6.3	4.7	6.8	4.7	7.1	5.0	7.3	5.0	7.8	4.9	8.4	4.9
	40.0	6.2	4.6	6.3	4.7	6.7	4.7	7.0	4.9	7.2	4.9	7.8	4.9	8.3	4.9
43.0	6.1	4.5	6.2	4.6	6.7	4.6	6.9	4.9	7.1	4.9	7.7	4.9	8.2	4.8	

kcal/h=kW x 860 , BTU/h = kW x 3,412

8. Cooling [Floor standing (Exposed 2-way/Exposed/Concealed type)]

PFFY-P-VLRMM-E

CA:Capacity(kW) , SHC:Sensible Heat Capacity(kW)

Model size (Rated kW)	Outdoor air temp. °C D.B.	Indoor air temp.													
		21.5°C D.B. 15°C W.B.		23°C D.B. 16°C W.B.		25°C D.B. 18°C W.B.		27°C D.B. 19°C W.B.		28°C D.B. 20°C W.B.		30°C D.B. 22°C W.B.		32°C D.B. 24°C W.B.	
		CA	SHC	CA	SHC	CA	SHC	CA	SHC	CA	SHC	CA	SHC	CA	SHC
20 (2.2)	20.0	2.1	1.7	2.1	1.7	2.3	1.7	2.4	1.8	2.4	1.8	2.6	1.8	2.8	1.8
	22.5	2.1	1.6	2.1	1.7	2.3	1.7	2.3	1.8	2.4	1.8	2.6	1.8	2.7	1.8
	25.0	2.0	1.6	2.1	1.7	2.2	1.7	2.3	1.8	2.4	1.8	2.5	1.8	2.7	1.7
	27.5	2.0	1.6	2.1	1.7	2.2	1.7	2.3	1.8	2.4	1.8	2.5	1.8	2.7	1.7
	30.0	2.0	1.6	2.0	1.7	2.2	1.7	2.3	1.8	2.3	1.8	2.5	1.7	2.7	1.7
	32.5	2.0	1.6	2.0	1.7	2.2	1.6	2.2	1.8	2.3	1.8	2.5	1.7	2.6	1.7
	35.0	2.0	1.6	2.0	1.6	2.1	1.6	2.2	1.7	2.3	1.7	2.5	1.7	2.6	1.7
	37.5	1.9	1.6	2.0	1.6	2.1	1.6	2.2	1.7	2.3	1.7	2.4	1.7	2.6	1.7
	40.0	1.9	1.6	1.9	1.6	2.1	1.6	2.2	1.7	2.2	1.7	2.4	1.7	2.6	1.7
43.0	1.9	1.6	1.9	1.6	2.1	1.6	2.1	1.7	2.2	1.7	2.4	1.7	2.5	1.7	
25 (2.8)	20.0	2.6	1.9	2.7	2.0	2.9	2.0	3.0	2.1	3.1	2.1	3.3	2.1	3.5	2.0
	22.5	2.6	1.9	2.7	2.0	2.9	2.0	3.0	2.1	3.1	2.1	3.3	2.0	3.5	2.0
	25.0	2.6	1.9	2.7	2.0	2.9	1.9	2.9	2.1	3.0	2.1	3.2	2.0	3.5	2.0
	27.5	2.6	1.9	2.6	1.9	2.8	1.9	2.9	2.0	3.0	2.0	3.2	2.0	3.4	2.0
	30.0	2.5	1.9	2.6	1.9	2.8	1.9	2.9	2.0	3.0	2.0	3.2	2.0	3.4	2.0
	32.5	2.5	1.9	2.6	1.9	2.8	1.9	2.9	2.0	3.0	2.0	3.2	2.0	3.4	2.0
	35.0	2.5	1.9	2.5	1.9	2.7	1.9	2.8	2.0	2.9	2.0	3.1	2.0	3.3	2.0
	37.5	2.5	1.8	2.5	1.9	2.7	1.9	2.8	2.0	2.9	2.0	3.1	2.0	3.3	2.0
	40.0	2.4	1.8	2.5	1.9	2.7	1.9	2.8	2.0	2.9	2.0	3.1	2.0	3.3	1.9
43.0	2.4	1.8	2.4	1.8	2.6	1.8	2.7	2.0	2.8	2.0	3.0	1.9	3.2	1.9	
32 (3.6)	20.0	3.4	2.5	3.5	2.5	3.7	2.5	3.9	2.7	4.0	2.7	4.3	2.6	4.5	2.6
	22.5	3.4	2.5	3.5	2.5	3.7	2.5	3.8	2.6	4.0	2.6	4.2	2.6	4.5	2.6
	25.0	3.3	2.4	3.4	2.5	3.7	2.5	3.8	2.6	3.9	2.6	4.2	2.6	4.4	2.6
	27.5	3.3	2.4	3.4	2.5	3.6	2.5	3.8	2.6	3.9	2.6	4.1	2.6	4.4	2.5
	30.0	3.3	2.4	3.3	2.5	3.6	2.4	3.7	2.6	3.8	2.6	4.1	2.6	4.4	2.5
	32.5	3.2	2.4	3.3	2.4	3.5	2.4	3.7	2.6	3.8	2.6	4.1	2.5	4.3	2.5
	35.0	3.2	2.4	3.3	2.4	3.5	2.4	3.6	2.5	3.8	2.6	4.0	2.5	4.3	2.5
	37.5	3.2	2.3	3.2	2.4	3.5	2.4	3.6	2.5	3.7	2.5	4.0	2.5	4.2	2.5
	40.0	3.1	2.3	3.2	2.4	3.4	2.4	3.5	2.5	3.7	2.5	3.9	2.5	4.2	2.5
43.0	3.1	2.3	3.1	2.4	3.4	2.4	3.5	2.5	3.6	2.5	3.9	2.5	4.2	2.5	
40 (4.5)	20.0	4.3	3.1	4.4	3.2	4.7	3.2	4.8	3.4	5.0	3.3	5.3	3.3	5.7	3.3
	22.5	4.2	3.1	4.3	3.2	4.6	3.1	4.8	3.3	4.9	3.3	5.3	3.3	5.6	3.2
	25.0	4.2	3.1	4.3	3.1	4.6	3.1	4.7	3.3	4.9	3.3	5.2	3.3	5.6	3.2
	27.5	4.1	3.0	4.2	3.1	4.5	3.1	4.7	3.3	4.8	3.3	5.2	3.2	5.5	3.2
	30.0	4.1	3.0	4.2	3.1	4.5	3.1	4.6	3.3	4.8	3.2	5.1	3.2	5.5	3.2
	32.5	4.0	3.0	4.1	3.1	4.4	3.1	4.6	3.2	4.7	3.2	5.1	3.2	5.4	3.2
	35.0	4.0	3.0	4.1	3.0	4.4	3.0	4.5	3.2	4.7	3.2	5.0	3.2	5.4	3.1
	37.5	4.0	3.0	4.0	3.0	4.3	3.0	4.5	3.2	4.6	3.2	5.0	3.2	5.3	3.1
	40.0	3.9	2.9	4.0	3.0	4.3	3.0	4.4	3.2	4.6	3.2	4.9	3.1	5.3	3.1
43.0	3.9	2.9	3.9	3.0	4.2	3.0	4.4	3.1	4.5	3.1	4.9	3.1	5.2	3.1	
50 (5.6)	20.0	5.3	3.9	5.5	4.0	5.8	4.0	6.0	4.2	6.2	4.2	6.6	4.2	7.0	4.1
	22.5	5.2	3.9	5.4	4.0	5.8	4.0	6.0	4.2	6.2	4.2	6.6	4.2	7.0	4.1
	25.0	5.2	3.9	5.3	4.0	5.7	3.9	5.9	4.2	6.1	4.2	6.5	4.1	6.9	4.1
	27.5	5.1	3.8	5.3	3.9	5.6	3.9	5.8	4.2	6.0	4.1	6.4	4.1	6.9	4.1
	30.0	5.1	3.8	5.2	3.9	5.6	3.9	5.8	4.1	6.0	4.1	6.4	4.1	6.8	4.0
	32.5	5.0	3.8	5.1	3.9	5.5	3.9	5.7	4.1	5.9	4.1	6.3	4.1	6.7	4.0
	35.0	5.0	3.8	5.1	3.8	5.4	3.8	5.6	4.1	5.8	4.1	6.2	4.0	6.7	4.0
	37.5	4.9	3.7	5.0	3.8	5.4	3.8	5.6	4.1	5.8	4.0	6.2	4.0	6.6	4.0
	40.0	4.9	3.7	4.9	3.8	5.3	3.8	5.5	4.0	5.7	4.0	6.1	4.0	6.5	3.9
43.0	4.8	3.7	4.9	3.7	5.2	3.7	5.4	4.0	5.6	4.0	6.0	4.0	6.5	3.9	
63 (7.1)	20.0	6.7	4.8	6.9	5.0	7.4	5.0	7.6	5.2	7.9	5.2	8.4	5.1	8.9	5.1
	22.5	6.6	4.8	6.8	4.9	7.3	4.9	7.6	5.2	7.8	5.2	8.3	5.1	8.8	5.0
	25.0	6.6	4.8	6.8	4.9	7.2	4.9	7.5	5.2	7.7	5.1	8.2	5.1	8.8	5.0
	27.5	6.5	4.7	6.7	4.9	7.2	4.8	7.4	5.1	7.6	5.1	8.2	5.1	8.7	5.0
	30.0	6.4	4.7	6.6	4.8	7.1	4.8	7.3	5.1	7.6	5.1	8.1	5.0	8.6	5.0
	32.5	6.4	4.7	6.5	4.8	7.0	4.8	7.2	5.1	7.5	5.0	8.0	5.0	8.5	4.9
	35.0	6.3	4.6	6.4	4.7	6.9	4.7	7.1	5.0	7.4	5.0	7.9	5.0	8.5	4.9
	37.5	6.2	4.6	6.3	4.7	6.8	4.7	7.1	5.0	7.3	5.0	7.8	4.9	8.4	4.9
	40.0	6.2	4.6	6.3	4.7	6.7	4.7	7.0	4.9	7.2	4.9	7.8	4.9	8.3	4.9
43.0	6.1	4.5	6.2	4.6	6.7	4.6	6.9	4.9	7.1	4.9	7.7	4.9	8.2	4.8	

kcal/h=kW x 860 , BTU/h = kW x 3,412

9. Heating [All indoor units]

9-1. Heating capacity with PUHY,PURY-RP200-250YJM

All Indoor units		SHC:Sensible Heat Capacity(kW)				All Indoor units		SHC:Sensible Heat Capacity(kW)			
Model size (Rated kW)	Outdoor air temp. °C W.B.	Indoor air temp.				Model size (Rated kW)	Outdoor air temp. °C W.B.	Indoor air temp.			
		15°C D.B.	20°C D.B.	25°C D.B.	27°C D.B.			15°C D.B.	20°C D.B.	25°C D.B.	27°C D.B.
		SHC	SHC	SHC	SHC			SHC	SHC	SHC	SHC
15 (1.9)	-20.0	1.3	1.3	1.3	1.3	71 (9.0)	-20.0	6.2	6.1	6.1	6.0
	-15.0	1.4	1.4	1.4	1.3		-15.0	6.7	6.7	6.5	6.3
	-10.0	1.6	1.6	1.5	1.3		-10.0	7.4	7.4	7.1	6.3
	-5.0	1.8	1.8	1.5	1.3		-5.0	8.4	8.3	7.2	6.3
	0.0	1.9	1.9	1.5	1.3		0.0	9.1	9.0	7.2	6.3
	2.5	1.9	1.9	1.5	1.3		2.5	9.1	9.0	7.2	6.3
	6.0	1.9	1.9	1.5	1.3		6.0	9.1	9.0	7.2	6.3
	7.5	2.0	1.9	1.5	1.3		7.5	9.3	9.0	7.2	6.3
	10.0	2.1	1.9	1.5	1.3		10.0	9.8	9.0	7.2	6.3
	12.5	2.2	1.9	1.5	1.3		12.5	10.4	9.0	7.2	6.3
15.5	2.4	1.9	1.5	1.3	15.5	11.3	9.0	7.2	6.3		
20 (2.5)	-20.0	1.7	1.7	1.7	1.7	80 (10.0)	-20.0	6.9	6.8	6.8	6.7
	-15.0	1.9	1.9	1.8	1.7		-15.0	7.5	7.5	7.2	6.9
	-10.0	2.1	2.0	2.0	1.8		-10.0	8.3	8.2	7.9	7.0
	-5.0	2.3	2.3	2.0	1.8		-5.0	9.4	9.3	8.0	7.0
	0.0	2.5	2.5	2.0	1.8		0.0	10.1	10.0	8.0	7.0
	2.5	2.5	2.5	2.0	1.8		2.5	10.1	10.0	8.0	7.0
	6.0	2.5	2.5	2.0	1.8		6.0	10.1	10.0	8.0	7.0
	7.5	2.6	2.5	2.0	1.8		7.5	10.4	10.0	8.0	7.0
	10.0	2.7	2.5	2.0	1.8		10.0	10.9	10.0	8.0	7.0
	12.5	2.9	2.5	2.0	1.8		12.5	11.6	10.0	8.0	7.0
15.5	3.1	2.5	2.0	1.8	15.5	12.6	10.0	8.0	7.0		
25 (3.2)	-20.0	2.2	2.2	2.2	2.1	100 (12.5)	-20.0	8.7	8.5	8.5	8.4
	-15.0	2.4	2.4	2.3	2.2		-15.0	9.3	9.3	9.0	8.7
	-10.0	2.6	2.6	2.5	2.2		-10.0	10.3	10.2	9.9	8.8
	-5.0	3.0	3.0	2.6	2.2		-5.0	11.7	11.6	10.0	8.8
	0.0	3.2	3.2	2.6	2.2		0.0	12.6	12.5	10.0	8.8
	2.5	3.2	3.2	2.6	2.2		2.5	12.6	12.5	10.0	8.8
	6.0	3.2	3.2	2.6	2.2		6.0	12.6	12.5	10.0	8.8
	7.5	3.3	3.2	2.6	2.2		7.5	12.9	12.5	10.0	8.8
	10.0	3.5	3.2	2.6	2.2		10.0	13.6	12.5	10.0	8.8
	12.5	3.7	3.2	2.6	2.2		12.5	14.5	12.5	10.0	8.8
15.5	4.0	3.2	2.6	2.2	15.5	15.7	12.5	10.0	8.8		
32 (4.0)	-20.0	2.8	2.7	2.7	2.7	125 (16.0)	-20.0	11.1	10.9	10.8	10.7
	-15.0	3.0	3.0	2.9	2.8		-15.0	11.9	11.9	11.5	11.1
	-10.0	3.3	3.3	3.2	2.8		-10.0	13.2	13.1	12.6	11.2
	-5.0	3.7	3.7	3.2	2.8		-5.0	15.0	14.8	12.8	11.2
	0.0	4.0	4.0	3.2	2.8		0.0	16.2	16.0	12.8	11.2
	2.5	4.0	4.0	3.2	2.8		2.5	16.2	16.0	12.8	11.2
	6.0	4.0	4.0	3.2	2.8		6.0	16.2	16.0	12.8	11.2
	7.5	4.1	4.0	3.2	2.8		7.5	16.6	16.0	12.8	11.2
	10.0	4.4	4.0	3.2	2.8		10.0	17.4	16.0	12.8	11.2
	12.5	4.6	4.0	3.2	2.8		12.5	18.5	16.0	12.8	11.2
15.5	5.0	4.0	3.2	2.8	15.5	20.1	16.0	12.8	11.2		
40 (5.0)	-20.0	3.5	3.4	3.4	3.3	140 (18.0)	-20.0	12.5	12.2	12.2	12.1
	-15.0	3.7	3.7	3.6	3.5		-15.0	13.4	13.4	12.9	12.5
	-10.0	4.1	4.1	3.9	3.5		-10.0	14.9	14.7	14.2	12.6
	-5.0	4.7	4.6	4.0	3.5		-5.0	16.9	16.7	14.4	12.6
	0.0	5.1	5.0	4.0	3.5		0.0	18.2	18.0	14.4	12.6
	2.5	5.1	5.0	4.0	3.5		2.5	18.2	18.0	14.4	12.6
	6.0	5.1	5.0	4.0	3.5		6.0	18.2	18.0	14.4	12.6
	7.5	5.2	5.0	4.0	3.5		7.5	18.6	18.0	14.4	12.6
	10.0	5.5	5.0	4.0	3.5		10.0	19.6	18.0	14.4	12.6
	12.5	5.8	5.0	4.0	3.5		12.5	20.9	18.0	14.4	12.6
15.5	6.3	5.0	4.0	3.5	15.5	22.6	18.0	14.4	12.6		
50 (6.3)	-20.0	4.4	4.3	4.3	4.2	200 (25.0)	-20.0	17.3	17.0	16.9	16.7
	-15.0	4.7	4.7	4.5	4.4		-15.0	18.6	18.6	18.0	17.4
	-10.0	5.2	5.2	5.0	4.4		-10.0	20.7	20.5	19.7	17.5
	-5.0	5.9	5.8	5.0	4.4		-5.0	23.4	23.1	20.0	17.5
	0.0	6.4	6.3	5.0	4.4		0.0	25.3	25.0	20.0	17.5
	2.5	6.4	6.3	5.0	4.4		2.5	25.3	25.0	20.0	17.5
	6.0	6.4	6.3	5.0	4.4		6.0	25.3	25.0	20.0	17.5
	7.5	6.5	6.3	5.0	4.4		7.5	25.9	25.0	20.0	17.5
	10.0	6.9	6.3	5.0	4.4		10.0	27.3	25.0	20.0	17.5
	12.5	7.3	6.3	5.0	4.4		12.5	29.0	25.0	20.0	17.5
15.5	7.9	6.3	5.0	4.4	15.5	31.4	25.0	20.0	17.5		
63 (8.0)	-20.0	5.5	5.4	5.4	5.4	250 (31.5)	-20.0	21.8	21.4	21.3	21.1
	-15.0	6.0	6.0	5.7	5.6		-15.0	23.5	23.5	22.6	21.9
	-10.0	6.6	6.6	6.3	5.6		-10.0	26.1	25.8	24.9	22.1
	-5.0	7.5	7.4	6.4	5.6		-5.0	29.5	29.1	25.2	22.1
	0.0	8.1	8.0	6.4	5.6		0.0	31.8	31.5	25.2	22.1
	2.5	8.1	8.0	6.4	5.6		2.5	31.8	31.5	25.2	22.1
	6.0	8.1	8.0	6.4	5.6		6.0	31.8	31.5	25.2	22.1
	7.5	8.3	8.0	6.4	5.6		7.5	32.6	31.5	25.2	22.1
	10.0	8.7	8.0	6.4	5.6		10.0	34.3	31.5	25.2	22.1
	12.5	9.3	8.0	6.4	5.6		12.5	36.5	31.5	25.2	22.1
15.5	10.1	8.0	6.4	5.6	15.5	39.6	31.5	25.2	22.1		

kcal/h=kW x 860 , BTU/h = kW x 3,412

kcal/h=kW x 860 , BTU/h = kW x 3,412

9. Heating [All indoor units]

9-2. Heating capacity with PUHY-RP300-400Y(S)JM,PURY-RP300YJM

All Indoor units		SHC:Sensible Heat Capacity(kW)				All Indoor units		SHC:Sensible Heat Capacity(kW)			
Model size (Rated kW)	Outdoor air temp. °C W.B.	Indoor air temp.				Model size (Rated kW)	Outdoor air temp. °C W.B.	Indoor air temp.			
		15°C D.B.	20°C D.B.	25°C D.B.	27°C D.B.			15°C D.B.	20°C D.B.	25°C D.B.	27°C D.B.
		SHC	SHC	SHC	SHC			SHC	SHC	SHC	SHC
15 (1.9)	-20.0	1.2	1.2	1.2	1.2	71 (9.0)	-20.0	5.8	5.8	5.8	5.6
	-15.0	1.3	1.3	1.3	1.2		-15.0	6.3	6.3	6.2	5.8
	-10.0	1.5	1.5	1.4	1.2		-10.0	6.9	6.9	6.7	5.8
	-5.0	1.6	1.7	1.4	1.2		-5.0	7.8	7.8	6.7	5.8
	0.0	1.8	1.8	1.4	1.2		0.0	8.8	8.8	6.7	5.8
	2.5	1.9	1.9	1.4	1.2		2.5	9.0	9.0	6.7	5.8
	6.0	1.9	1.9	1.4	1.2		6.0	9.2	9.0	6.7	5.8
	7.5	2.0	1.9	1.4	1.2		7.5	9.5	9.0	6.7	5.8
	10.0	2.1	1.9	1.4	1.2		10.0	9.9	9.0	6.7	5.8
	12.5	2.2	1.9	1.4	1.2		12.5	10.3	9.0	6.7	5.8
15.5	2.2	1.9	1.4	1.2	15.5	10.3	9.0	6.7	5.8		
20 (2.5)	-20.0	1.6	1.6	1.6	1.6	80 (10.0)	-20.0	6.4	6.5	6.4	6.2
	-15.0	1.7	1.7	1.7	1.6		-15.0	7.0	7.0	6.9	6.4
	-10.0	1.9	1.9	1.9	1.6		-10.0	7.7	7.7	7.5	6.4
	-5.0	2.2	2.2	1.9	1.6		-5.0	8.7	8.7	7.5	6.4
	0.0	2.4	2.4	1.9	1.6		0.0	9.7	9.7	7.5	6.4
	2.5	2.5	2.5	1.9	1.6		2.5	10.0	10.0	7.5	6.4
	6.0	2.6	2.5	1.9	1.6		6.0	10.2	10.0	7.5	6.4
	7.5	2.6	2.5	1.9	1.6		7.5	10.5	10.0	7.5	6.4
	10.0	2.8	2.5	1.9	1.6		10.0	11.1	10.0	7.5	6.4
	12.5	2.9	2.5	1.9	1.6		12.5	11.5	10.0	7.5	6.4
15.5	2.9	2.5	1.9	1.6	15.5	11.5	10.0	7.5	6.4		
25 (3.2)	-20.0	2.1	2.1	2.1	2.0	100 (12.5)	-20.0	8.0	8.1	8.0	7.8
	-15.0	2.2	2.2	2.2	2.0		-15.0	8.7	8.7	8.6	8.0
	-10.0	2.5	2.5	2.4	2.0		-10.0	9.6	9.6	9.3	8.0
	-5.0	2.8	2.8	2.4	2.0		-5.0	10.8	10.9	9.3	8.0
	0.0	3.1	3.1	2.4	2.0		0.0	12.2	12.2	9.3	8.0
	2.5	3.2	3.2	2.4	2.0		2.5	12.5	12.5	9.3	8.0
	6.0	3.3	3.2	2.4	2.0		6.0	12.8	12.5	9.3	8.0
	7.5	3.4	3.2	2.4	2.0		7.5	13.2	12.5	9.3	8.0
	10.0	3.5	3.2	2.4	2.0		10.0	13.8	12.5	9.3	8.0
	12.5	3.7	3.2	2.4	2.0		12.5	14.3	12.5	9.3	8.0
15.5	3.7	3.2	2.4	2.0	15.5	14.3	12.5	9.3	8.0		
32 (4.0)	-20.0	2.6	2.6	2.6	2.5	125 (16.0)	-20.0	10.3	10.3	10.3	9.9
	-15.0	2.8	2.8	2.8	2.6		-15.0	11.1	11.2	11.1	10.2
	-10.0	3.1	3.1	3.0	2.6		-10.0	12.3	12.3	11.9	10.2
	-5.0	3.5	3.5	3.0	2.6		-5.0	13.9	13.9	11.9	10.2
	0.0	3.9	3.9	3.0	2.6		0.0	15.6	15.6	11.9	10.2
	2.5	4.0	4.0	3.0	2.6		2.5	16.0	16.0	11.9	10.2
	6.0	4.1	4.0	3.0	2.6		6.0	16.4	16.0	11.9	10.2
	7.5	4.2	4.0	3.0	2.6		7.5	16.9	16.0	11.9	10.2
	10.0	4.4	4.0	3.0	2.6		10.0	17.7	16.0	11.9	10.2
	12.5	4.6	4.0	3.0	2.6		12.5	18.3	16.0	11.9	10.2
15.5	4.6	4.0	3.0	2.6	15.5	18.3	16.0	11.9	10.2		
40 (5.0)	-20.0	3.2	3.2	3.2	3.1	140 (18.0)	-20.0	11.5	11.6	11.5	11.2
	-15.0	3.5	3.5	3.5	3.2		-15.0	12.5	12.6	12.5	11.5
	-10.0	3.8	3.8	3.7	3.2		-10.0	13.8	13.8	13.4	11.5
	-5.0	4.3	4.3	3.7	3.2		-5.0	15.6	15.6	13.4	11.5
	0.0	4.9	4.9	3.7	3.2		0.0	17.5	17.5	13.4	11.5
	2.5	5.0	5.0	3.7	3.2		2.5	18.0	18.0	13.4	11.5
	6.0	5.1	5.0	3.7	3.2		6.0	18.4	18.0	13.4	11.5
	7.5	5.3	5.0	3.7	3.2		7.5	19.0	18.0	13.4	11.5
	10.0	5.5	5.0	3.7	3.2		10.0	19.9	18.0	13.4	11.5
	12.5	5.7	5.0	3.7	3.2		12.5	20.6	18.0	13.4	11.5
15.5	5.7	5.0	3.7	3.2	15.5	20.6	18.0	13.4	11.5		
50 (6.3)	-20.0	4.0	4.1	4.0	3.9	200 (25.0)	-20.0	16.0	16.1	16.0	15.5
	-15.0	4.4	4.4	4.4	4.0		-15.0	17.4	17.5	17.3	16.0
	-10.0	4.8	4.8	4.7	4.0		-10.0	19.2	19.2	18.6	16.0
	-5.0	5.5	5.5	4.7	4.0		-5.0	21.7	21.7	18.6	16.0
	0.0	6.1	6.1	4.7	4.0		0.0	24.3	24.3	18.6	16.0
	2.5	6.3	6.3	4.7	4.0		2.5	25.0	25.0	18.6	16.0
	6.0	6.5	6.3	4.7	4.0		6.0	25.6	25.0	18.6	16.0
	7.5	6.6	6.3	4.7	4.0		7.5	26.4	25.0	18.6	16.0
	10.0	7.0	6.3	4.7	4.0		10.0	27.6	25.0	18.6	16.0
	12.5	7.2	6.3	4.7	4.0		12.5	28.6	25.0	18.6	16.0
15.5	7.2	6.3	4.7	4.0	15.5	28.6	25.0	18.6	16.0		
63 (8.0)	-20.0	5.1	5.2	5.1	5.0	250 (31.5)	-20.0	20.2	20.3	20.2	19.6
	-15.0	5.6	5.6	5.5	5.1		-15.0	21.9	22.0	21.8	20.2
	-10.0	6.1	6.2	6.0	5.1		-10.0	24.2	24.2	23.5	20.2
	-5.0	6.9	7.0	6.0	5.1		-5.0	27.3	27.4	23.5	20.2
	0.0	7.8	7.8	6.0	5.1		0.0	30.6	30.6	23.5	20.2
	2.5	8.0	8.0	6.0	5.1		2.5	31.5	31.5	23.5	20.2
	6.0	8.2	8.0	6.0	5.1		6.0	32.3	31.5	23.5	20.2
	7.5	8.4	8.0	6.0	5.1		7.5	33.2	31.5	23.5	20.2
	10.0	8.8	8.0	6.0	5.1		10.0	34.8	31.5	23.5	20.2
	12.5	9.2	8.0	6.0	5.1		12.5	36.1	31.5	23.5	20.2
15.5	9.2	8.0	6.0	5.1	15.5	36.1	31.5	23.5	20.2		

kcal/h=kW x 860 , BTU/h = kW x 3,412

kcal/h=kW x 860 , BTU/h = kW x 3,412

9. Heating [All indoor units]

9-3. Heating capacity with PUHY-RP450-650YSJM

All Indoor units						All Indoor units					
Model size (Rated kW)	Outdoor air temp. °C W.B.	SHC:Sensible Heat Capacity(kW)				Model size (Rated kW)	Outdoor air temp. °C W.B.	SHC:Sensible Heat Capacity(kW)			
		Indoor air temp.						Indoor air temp.			
		15°C D.B.	20°C D.B.	25°C D.B.	27°C D.B.			15°C D.B.	20°C D.B.	25°C D.B.	27°C D.B.
15 (1.9)	-20.0	1.2	1.1	1.2	1.1	71 (9.0)	-20.0	5.5	5.4	5.4	5.3
	-15.0	1.3	1.3	1.2	1.2		-15.0	6.1	6.0	5.8	5.7
	-10.0	1.4	1.4	1.3	1.3		-10.0	6.8	6.6	6.4	6.2
	-5.0	1.6	1.6	1.5	1.3		-5.0	7.5	7.4	7.1	6.4
	0.0	1.8	1.8	1.5	1.3		0.0	8.3	8.3	7.1	6.4
	2.5	1.8	1.8	1.5	1.3		2.5	8.7	8.7	7.1	6.4
	6.0	1.9	1.9	1.5	1.3		6.0	9.2	9.0	7.1	6.4
	7.5	2.0	1.9	1.5	1.3		7.5	9.5	9.0	7.1	6.4
	10.0	2.1	1.9	1.5	1.3		10.0	9.9	9.0	7.1	6.4
	12.5	2.2	1.9	1.5	1.3		12.5	10.3	9.0	7.1	6.4
15.5	2.2	1.9	1.5	1.3	15.5	10.4	9.0	7.1	6.4		
20 (2.5)	-20.0	1.5	1.5	1.5	1.5	80 (10.0)	-20.0	6.2	6.0	6.1	5.9
	-15.0	1.7	1.7	1.6	1.6		-15.0	6.8	6.6	6.5	6.3
	-10.0	1.9	1.8	1.8	1.7		-10.0	7.5	7.3	7.1	6.9
	-5.0	2.1	2.1	2.0	1.8		-5.0	8.3	8.3	7.9	7.1
	0.0	2.3	2.3	2.0	1.8		0.0	9.2	9.2	7.9	7.1
	2.5	2.4	2.4	2.0	1.8		2.5	9.7	9.7	7.9	7.1
	6.0	2.6	2.5	2.0	1.8		6.0	10.2	10.0	7.9	7.1
	7.5	2.6	2.5	2.0	1.8		7.5	10.5	10.0	7.9	7.1
	10.0	2.7	2.5	2.0	1.8		10.0	11.0	10.0	7.9	7.1
	12.5	2.9	2.5	2.0	1.8		12.5	11.5	10.0	7.9	7.1
15.5	2.9	2.5	2.0	1.8	15.5	11.5	10.0	7.9	7.1		
25 (3.2)	-20.0	2.0	1.9	1.9	1.9	100 (12.5)	-20.0	7.7	7.5	7.6	7.4
	-15.0	2.2	2.1	2.1	2.0		-15.0	8.5	8.3	8.1	7.9
	-10.0	2.4	2.3	2.3	2.2		-10.0	9.4	9.1	8.9	8.7
	-5.0	2.7	2.6	2.5	2.3		-5.0	10.4	10.3	9.9	8.9
	0.0	3.0	3.0	2.5	2.3		0.0	11.5	11.5	9.9	8.9
	2.5	3.1	3.1	2.5	2.3		2.5	12.1	12.1	9.9	8.9
	6.0	3.3	3.2	2.5	2.3		6.0	12.8	12.5	9.9	8.9
	7.5	3.4	3.2	2.5	2.3		7.5	13.1	12.5	9.9	8.9
	10.0	3.5	3.2	2.5	2.3		10.0	13.7	12.5	9.9	8.9
	12.5	3.7	3.2	2.5	2.3		12.5	14.3	12.5	9.9	8.9
15.5	3.7	3.2	2.5	2.3	15.5	14.4	12.5	9.9	8.9		
32 (4.0)	-20.0	2.5	2.4	2.4	2.4	125 (16.0)	-20.0	9.9	9.6	9.7	9.4
	-15.0	2.7	2.7	2.6	2.5		-15.0	10.9	10.6	10.4	10.1
	-10.0	3.0	2.9	2.8	2.8		-10.0	12.0	11.7	11.4	11.1
	-5.0	3.3	3.3	3.2	2.8		-5.0	13.3	13.2	12.7	11.3
	0.0	3.7	3.7	3.2	2.8		0.0	14.8	14.8	12.7	11.3
	2.5	3.9	3.9	3.2	2.8		2.5	15.5	15.5	12.7	11.3
	6.0	4.1	4.0	3.2	2.8		6.0	16.3	16.0	12.7	11.3
	7.5	4.2	4.0	3.2	2.8		7.5	16.8	16.0	12.7	11.3
	10.0	4.4	4.0	3.2	2.8		10.0	17.6	16.0	12.7	11.3
	12.5	4.6	4.0	3.2	2.8		12.5	18.4	16.0	12.7	11.3
15.5	4.6	4.0	3.2	2.8	15.5	18.5	16.0	12.7	11.3		
40 (5.0)	-20.0	3.1	3.0	3.0	2.9	140 (18.0)	-20.0	11.1	10.8	10.9	10.6
	-15.0	3.4	3.3	3.2	3.1		-15.0	12.3	11.9	11.7	11.3
	-10.0	3.8	3.6	3.6	3.5		-10.0	13.5	13.1	12.8	12.5
	-5.0	4.2	4.1	4.0	3.5		-5.0	15.0	14.9	14.3	12.8
	0.0	4.6	4.6	4.0	3.5		0.0	16.6	16.6	14.3	12.8
	2.5	4.9	4.9	4.0	3.5		2.5	17.5	17.5	14.3	12.8
	6.0	5.1	5.0	4.0	3.5		6.0	18.4	18.0	14.3	12.8
	7.5	5.3	5.0	4.0	3.5		7.5	18.9	18.0	14.3	12.8
	10.0	5.5	5.0	4.0	3.5		10.0	19.8	18.0	14.3	12.8
	12.5	5.7	5.0	4.0	3.5		12.5	20.7	18.0	14.3	12.8
15.5	5.8	5.0	4.0	3.5	15.5	20.8	18.0	14.3	12.8		
50 (6.3)	-20.0	3.9	3.8	3.8	3.7	200 (25.0)	-20.0	15.4	15.0	15.1	14.7
	-15.0	4.3	4.2	4.1	4.0		-15.0	17.1	16.6	16.2	15.7
	-10.0	4.7	4.6	4.5	4.4		-10.0	18.8	18.2	17.8	17.3
	-5.0	5.2	5.2	5.0	4.5		-5.0	20.8	20.6	19.8	17.7
	0.0	5.8	5.8	5.0	4.5		0.0	23.1	23.0	19.8	17.7
	2.5	6.1	6.1	5.0	4.5		2.5	24.3	24.3	19.8	17.7
	6.0	6.4	6.3	5.0	4.5		6.0	25.5	25.0	19.8	17.7
	7.5	6.6	6.3	5.0	4.5		7.5	26.3	25.0	19.8	17.7
	10.0	6.9	6.3	5.0	4.5		10.0	27.4	25.0	19.8	17.7
	12.5	7.2	6.3	5.0	4.5		12.5	28.7	25.0	19.8	17.7
15.5	7.3	6.3	5.0	4.5	15.5	28.9	25.0	19.8	17.7		
63 (8.0)	-20.0	4.9	4.8	4.8	4.7	250 (31.5)	-20.0	19.4	18.9	19.1	18.6
	-15.0	5.5	5.3	5.2	5.0		-15.0	21.5	20.9	20.4	19.8
	-10.0	6.0	5.8	5.7	5.5		-10.0	23.6	23.0	22.4	21.8
	-5.0	6.7	6.6	6.3	5.7		-5.0	26.2	26.0	24.9	22.3
	0.0	7.4	7.4	6.3	5.7		0.0	29.1	29.0	25.0	22.3
	2.5	7.8	7.8	6.3	5.7		2.5	30.6	30.6	25.0	22.3
	6.0	8.2	8.0	6.3	5.7		6.0	32.2	31.5	25.0	22.3
	7.5	8.4	8.0	6.3	5.7		7.5	33.1	31.5	25.0	22.3
	10.0	8.8	8.0	6.3	5.7		10.0	34.6	31.5	25.0	22.3
	12.5	9.2	8.0	6.3	5.7		12.5	36.1	31.5	25.0	22.3
15.5	9.2	8.0	6.3	5.7	15.5	36.4	31.5	25.0	22.3		

kcal/h=kW x 860 , BTU/h = kW x 3,412

kcal/h=kW x 860 , BTU/h = kW x 3,412

9. Heating [All indoor units]

9-4. Heating capacity with PUHY-RP700-800YSJM

All Indoor units		SHC:Sensible Heat Capacity(kW)				All Indoor units		SHC:Sensible Heat Capacity(kW)			
Model size (Rated kW)	Outdoor air temp. °C W.B.	Indoor air temp.				Model size (Rated kW)	Outdoor air temp. °C W.B.	Indoor air temp.			
		15°C D.B.	20°C D.B.	25°C D.B.	27°C D.B.			15°C D.B.	20°C D.B.	25°C D.B.	27°C D.B.
		SHC	SHC	SHC	SHC			SHC	SHC	SHC	SHC
15 (1.9)	-20.0	1.3	1.3	1.3	1.3	71 (9.0)	-20.0	6.2	6.2	6.1	6.0
	-15.0	1.4	1.4	1.4	1.3		-15.0	6.8	6.8	6.5	6.3
	-10.0	1.6	1.6	1.5	1.3		-10.0	7.5	7.4	7.2	6.3
	-5.0	1.8	1.8	1.5	1.3		-5.0	8.5	8.4	7.2	6.3
	0.0	1.9	1.9	1.5	1.3		0.0	9.1	9.0	7.2	6.3
	2.5	1.9	1.9	1.5	1.3		2.5	9.1	9.0	7.2	6.3
	6.0	1.9	1.9	1.5	1.3		6.0	9.1	9.0	7.2	6.3
	7.5	2.0	1.9	1.5	1.3		7.5	9.3	9.0	7.2	6.3
	10.0	2.1	1.9	1.5	1.3		10.0	9.8	9.0	7.2	6.3
	12.5	2.2	1.9	1.5	1.3		12.5	10.4	9.0	7.2	6.3
15.5	2.4	1.9	1.5	1.3	15.5	11.3	9.0	7.2	6.3		
20 (2.5)	-20.0	1.7	1.7	1.7	1.7	80 (10.0)	-20.0	6.9	6.9	6.8	6.7
	-15.0	1.9	1.9	1.8	1.7		-15.0	7.6	7.5	7.3	6.9
	-10.0	2.1	2.1	2.0	1.8		-10.0	8.3	8.3	8.0	7.0
	-5.0	2.4	2.3	2.0	1.8		-5.0	9.4	9.3	8.0	7.0
	0.0	2.5	2.5	2.0	1.8		0.0	10.1	10.0	8.0	7.0
	2.5	2.5	2.5	2.0	1.8		2.5	10.1	10.0	8.0	7.0
	6.0	2.5	2.5	2.0	1.8		6.0	10.1	10.0	8.0	7.0
	7.5	2.6	2.5	2.0	1.8		7.5	10.4	10.0	8.0	7.0
	10.0	2.7	2.5	2.0	1.8		10.0	10.9	10.0	8.0	7.0
	12.5	2.9	2.5	2.0	1.8		12.5	11.6	10.0	8.0	7.0
15.5	3.1	2.5	2.0	1.8	15.5	12.6	10.0	8.0	7.0		
25 (3.2)	-20.0	2.2	2.2	2.2	2.1	100 (12.5)	-20.0	8.7	8.6	8.5	8.4
	-15.0	2.4	2.4	2.3	2.2		-15.0	9.4	9.4	9.1	8.7
	-10.0	2.7	2.6	2.6	2.2		-10.0	10.4	10.3	10.0	8.8
	-5.0	3.0	3.0	2.6	2.2		-5.0	11.8	11.7	10.0	8.8
	0.0	3.2	3.2	2.6	2.2		0.0	12.6	12.5	10.0	8.8
	2.5	3.2	3.2	2.6	2.2		2.5	12.6	12.5	10.0	8.8
	6.0	3.2	3.2	2.6	2.2		6.0	12.6	12.5	10.0	8.8
	7.5	3.3	3.2	2.6	2.2		7.5	12.9	12.5	10.0	8.8
	10.0	3.5	3.2	2.6	2.2		10.0	13.6	12.5	10.0	8.8
	12.5	3.7	3.2	2.6	2.2		12.5	14.5	12.5	10.0	8.8
15.5	4.0	3.2	2.6	2.2	15.5	15.7	12.5	10.0	8.8		
32 (4.0)	-20.0	2.8	2.7	2.7	2.7	125 (16.0)	-20.0	11.1	11.0	10.9	10.7
	-15.0	3.0	3.0	2.9	2.8		-15.0	12.1	12.0	11.6	11.1
	-10.0	3.3	3.3	3.2	2.8		-10.0	13.3	13.2	12.8	11.2
	-5.0	3.8	3.7	3.2	2.8		-5.0	15.1	14.9	12.8	11.2
	0.0	4.0	4.0	3.2	2.8		0.0	16.2	16.0	12.8	11.2
	2.5	4.0	4.0	3.2	2.8		2.5	16.2	16.0	12.8	11.2
	6.0	4.0	4.0	3.2	2.8		6.0	16.2	16.0	12.8	11.2
	7.5	4.1	4.0	3.2	2.8		7.5	16.6	16.0	12.8	11.2
	10.0	4.4	4.0	3.2	2.8		10.0	17.4	16.0	12.8	11.2
	12.5	4.6	4.0	3.2	2.8		12.5	18.5	16.0	12.8	11.2
15.5	5.0	4.0	3.2	2.8	15.5	20.1	16.0	12.8	11.2		
40 (5.0)	-20.0	3.5	3.4	3.4	3.3	140 (18.0)	-20.0	12.5	12.3	12.3	12.1
	-15.0	3.8	3.8	3.6	3.5		-15.0	13.6	13.5	13.1	12.5
	-10.0	4.2	4.1	4.0	3.5		-10.0	15.0	14.9	14.4	12.6
	-5.0	4.7	4.7	4.0	3.5		-5.0	17.0	16.8	14.4	12.6
	0.0	5.1	5.0	4.0	3.5		0.0	18.2	18.0	14.4	12.6
	2.5	5.1	5.0	4.0	3.5		2.5	18.2	18.0	14.4	12.6
	6.0	5.1	5.0	4.0	3.5		6.0	18.2	18.0	14.4	12.6
	7.5	5.2	5.0	4.0	3.5		7.5	18.6	18.0	14.4	12.6
	10.0	5.5	5.0	4.0	3.5		10.0	19.6	18.0	14.4	12.6
	12.5	5.8	5.0	4.0	3.5		12.5	20.9	18.0	14.4	12.6
15.5	6.3	5.0	4.0	3.5	15.5	22.6	18.0	14.4	12.6		
50 (6.3)	-20.0	4.4	4.3	4.3	4.2	200 (25.0)	-20.0	17.4	17.2	17.1	16.7
	-15.0	4.8	4.7	4.6	4.4		-15.0	18.9	18.8	18.2	17.4
	-10.0	5.2	5.2	5.0	4.4		-10.0	20.8	20.7	20.0	17.5
	-5.0	5.9	5.9	5.0	4.4		-5.0	23.6	23.4	20.0	17.5
	0.0	6.4	6.3	5.0	4.4		0.0	25.3	25.0	20.0	17.5
	2.5	6.4	6.3	5.0	4.4		2.5	25.3	25.0	20.0	17.5
	6.0	6.4	6.3	5.0	4.4		6.0	25.3	25.0	20.0	17.5
	7.5	6.5	6.3	5.0	4.4		7.5	25.9	25.0	20.0	17.5
	10.0	6.9	6.3	5.0	4.4		10.0	27.3	25.0	20.0	17.5
	12.5	7.3	6.3	5.0	4.4		12.5	29.0	25.0	20.0	17.5
15.5	7.9	6.3	5.0	4.4	15.5	31.4	25.0	20.0	17.5		
63 (8.0)	-20.0	5.6	5.5	5.5	5.4	250 (31.5)	-20.0	21.9	21.6	21.5	21.1
	-15.0	6.0	6.0	5.8	5.6		-15.0	23.8	23.7	22.9	21.9
	-10.0	6.7	6.6	6.4	5.6		-10.0	26.2	26.0	25.1	22.1
	-5.0	7.5	7.5	6.4	5.6		-5.0	29.7	29.4	25.2	22.1
	0.0	8.1	8.0	6.4	5.6		0.0	31.8	31.5	25.2	22.1
	2.5	8.1	8.0	6.4	5.6		2.5	31.8	31.5	25.2	22.1
	6.0	8.1	8.0	6.4	5.6		6.0	31.8	31.5	25.2	22.1
	7.5	8.3	8.0	6.4	5.6		7.5	32.6	31.5	25.2	22.1
	10.0	8.7	8.0	6.4	5.6		10.0	34.3	31.5	25.2	22.1
	12.5	9.3	8.0	6.4	5.6		12.5	36.5	31.5	25.2	22.1
15.5	10.1	8.0	6.4	5.6	15.5	39.6	31.5	25.2	22.1		

kcal/h=kW x 860 , BTU/h = kW x 3,412

kcal/h=kW x 860 , BTU/h = kW x 3,412

9. Heating [All indoor units]

9-5. Heating capacity with PUHY-RP850-900YSJM

All Indoor units						All Indoor units					
Model size (Rated kW)	Outdoor air temp. °C W.B.	SHC:Sensible Heat Capacity(kW)				Model size (Rated kW)	Outdoor air temp. °C W.B.	SHC:Sensible Heat Capacity(kW)			
		Indoor air temp.						Indoor air temp.			
		15°C D.B.	20°C D.B.	25°C D.B.	27°C D.B.			15°C D.B.	20°C D.B.	25°C D.B.	27°C D.B.
15 (1.9)	-20.0	1.2	1.2	1.2	1.2	71 (9.0)	-20.0	5.8	5.8	5.8	5.6
	-15.0	1.3	1.3	1.3	1.2		-15.0	6.3	6.3	6.2	5.8
	-10.0	1.5	1.5	1.4	1.2		-10.0	6.9	6.9	6.7	5.8
	-5.0	1.6	1.7	1.4	1.2		-5.0	7.8	7.8	6.7	5.8
	0.0	1.8	1.8	1.4	1.2		0.0	8.8	8.8	6.7	5.8
	2.5	1.9	1.9	1.4	1.2		2.5	9.0	9.0	6.7	5.8
	6.0	1.9	1.9	1.4	1.2		6.0	9.2	9.0	6.7	5.8
	7.5	2.0	1.9	1.4	1.2		7.5	9.5	9.0	6.7	5.8
	10.0	2.1	1.9	1.4	1.2		10.0	9.9	9.0	6.7	5.8
	12.5	2.2	1.9	1.4	1.2		12.5	10.3	9.0	6.7	5.8
15.5	2.2	1.9	1.4	1.2	15.5	10.3	9.0	6.7	5.8		
20 (2.5)	-20.0	1.6	1.6	1.6	1.6	80 (10.0)	-20.0	6.4	6.5	6.4	6.2
	-15.0	1.7	1.7	1.7	1.6		-15.0	7.0	7.0	6.9	6.4
	-10.0	1.9	1.9	1.9	1.6		-10.0	7.7	7.7	7.5	6.4
	-5.0	2.2	2.2	1.9	1.6		-5.0	8.7	8.7	7.5	6.4
	0.0	2.4	2.4	1.9	1.6		0.0	9.7	9.7	7.5	6.4
	2.5	2.5	2.5	1.9	1.6		2.5	10.0	10.0	7.5	6.4
	6.0	2.6	2.5	1.9	1.6		6.0	10.2	10.0	7.5	6.4
	7.5	2.6	2.5	1.9	1.6		7.5	10.5	10.0	7.5	6.4
	10.0	2.8	2.5	1.9	1.6		10.0	11.1	10.0	7.5	6.4
	12.5	2.9	2.5	1.9	1.6		12.5	11.5	10.0	7.5	6.4
15.5	2.9	2.5	1.9	1.6	15.5	11.5	10.0	7.5	6.4		
25 (3.2)	-20.0	2.1	2.1	2.1	2.0	100 (12.5)	-20.0	8.0	8.1	8.0	7.8
	-15.0	2.2	2.2	2.2	2.0		-15.0	8.7	8.7	8.6	8.0
	-10.0	2.5	2.5	2.4	2.0		-10.0	9.6	9.6	9.3	8.0
	-5.0	2.8	2.8	2.4	2.0		-5.0	10.8	10.9	9.3	8.0
	0.0	3.1	3.1	2.4	2.0		0.0	12.2	12.2	9.3	8.0
	2.5	3.2	3.2	2.4	2.0		2.5	12.5	12.5	9.3	8.0
	6.0	3.3	3.2	2.4	2.0		6.0	12.8	12.5	9.3	8.0
	7.5	3.4	3.2	2.4	2.0		7.5	13.2	12.5	9.3	8.0
	10.0	3.5	3.2	2.4	2.0		10.0	13.8	12.5	9.3	8.0
	12.5	3.7	3.2	2.4	2.0		12.5	14.3	12.5	9.3	8.0
15.5	3.7	3.2	2.4	2.0	15.5	14.3	12.5	9.3	8.0		
32 (4.0)	-20.0	2.6	2.6	2.6	2.5	125 (16.0)	-20.0	10.3	10.3	10.3	9.9
	-15.0	2.8	2.8	2.8	2.6		-15.0	11.1	11.2	11.1	10.2
	-10.0	3.1	3.1	3.0	2.6		-10.0	12.3	12.3	11.9	10.2
	-5.0	3.5	3.5	3.0	2.6		-5.0	13.9	13.9	11.9	10.2
	0.0	3.9	3.9	3.0	2.6		0.0	15.6	15.6	11.9	10.2
	2.5	4.0	4.0	3.0	2.6		2.5	16.0	16.0	11.9	10.2
	6.0	4.1	4.0	3.0	2.6		6.0	16.4	16.0	11.9	10.2
	7.5	4.2	4.0	3.0	2.6		7.5	16.9	16.0	11.9	10.2
	10.0	4.4	4.0	3.0	2.6		10.0	17.7	16.0	11.9	10.2
	12.5	4.6	4.0	3.0	2.6		12.5	18.3	16.0	11.9	10.2
15.5	4.6	4.0	3.0	2.6	15.5	18.3	16.0	11.9	10.2		
40 (5.0)	-20.0	3.2	3.2	3.2	3.1	140 (18.0)	-20.0	11.5	11.6	11.5	11.2
	-15.0	3.5	3.5	3.5	3.2		-15.0	12.5	12.6	12.5	11.5
	-10.0	3.8	3.8	3.7	3.2		-10.0	13.8	13.8	13.4	11.5
	-5.0	4.3	4.3	3.7	3.2		-5.0	15.6	15.6	13.4	11.5
	0.0	4.9	4.9	3.7	3.2		0.0	17.5	17.5	13.4	11.5
	2.5	5.0	5.0	3.7	3.2		2.5	18.0	18.0	13.4	11.5
	6.0	5.1	5.0	3.7	3.2		6.0	18.4	18.0	13.4	11.5
	7.5	5.3	5.0	3.7	3.2		7.5	19.0	18.0	13.4	11.5
	10.0	5.5	5.0	3.7	3.2		10.0	19.9	18.0	13.4	11.5
	12.5	5.7	5.0	3.7	3.2		12.5	20.6	18.0	13.4	11.5
15.5	5.7	5.0	3.7	3.2	15.5	20.6	18.0	13.4	11.5		
50 (6.3)	-20.0	4.0	4.1	4.0	3.9	200 (25.0)	-20.0	16.0	16.1	16.0	15.5
	-15.0	4.4	4.4	4.4	4.0		-15.0	17.4	17.5	17.3	16.0
	-10.0	4.8	4.8	4.7	4.0		-10.0	19.2	19.2	18.6	16.0
	-5.0	5.5	5.5	4.7	4.0		-5.0	21.7	21.7	18.6	16.0
	0.0	6.1	6.1	4.7	4.0		0.0	24.3	24.3	18.6	16.0
	2.5	6.3	6.3	4.7	4.0		2.5	25.0	25.0	18.6	16.0
	6.0	6.5	6.3	4.7	4.0		6.0	25.6	25.0	18.6	16.0
	7.5	6.6	6.3	4.7	4.0		7.5	26.4	25.0	18.6	16.0
	10.0	7.0	6.3	4.7	4.0		10.0	27.6	25.0	18.6	16.0
	12.5	7.2	6.3	4.7	4.0		12.5	28.6	25.0	18.6	16.0
15.5	7.2	6.3	4.7	4.0	15.5	28.6	25.0	18.6	16.0		
63 (8.0)	-20.0	5.1	5.2	5.1	5.0	250 (31.5)	-20.0	20.2	20.3	20.2	19.6
	-15.0	5.6	5.6	5.5	5.1		-15.0	21.9	22.0	21.8	20.2
	-10.0	6.1	6.2	6.0	5.1		-10.0	24.2	24.2	23.5	20.2
	-5.0	6.9	7.0	6.0	5.1		-5.0	27.3	27.4	23.5	20.2
	0.0	7.8	7.8	6.0	5.1		0.0	30.6	30.6	23.5	20.2
	2.5	8.0	8.0	6.0	5.1		2.5	31.5	31.5	23.5	20.2
	6.0	8.2	8.0	6.0	5.1		6.0	32.3	31.5	23.5	20.2
	7.5	8.4	8.0	6.0	5.1		7.5	33.2	31.5	23.5	20.2
	10.0	8.8	8.0	6.0	5.1		10.0	34.8	31.5	23.5	20.2
	12.5	9.2	8.0	6.0	5.1		12.5	36.1	31.5	23.5	20.2
15.5	9.2	8.0	6.0	5.1	15.5	36.1	31.5	23.5	20.2		

kcal/h=kW x 860 , BTU/h = kW x 3,412

kcal/h=kW x 860 , BTU/h = kW x 3,412

9. Heating [All indoor units]

9-6. Heating capacity with PUHY,PURY-RP200-250YJM "COP priority mode"

All Indoor units						All Indoor units					
Model size (Rated kW)	Outdoor air temp. °C W.B.	SHC:Sensible Heat Capacity(kW)				Model size (Rated kW)	Outdoor air temp. °C W.B.	SHC:Sensible Heat Capacity(kW)			
		Indoor air temp.						Indoor air temp.			
		15°C D.B.	20°C D.B.	25°C D.B.	27°C D.B.			15°C D.B.	20°C D.B.	25°C D.B.	27°C D.B.
15 (1.9)	-20.0	1.0	1.0	1.0	0.9	71 (9.0)	-20.0	4.6	4.5	4.5	4.5
	-15.0	1.2	1.2	1.1	1.1		-15.0	5.6	5.5	5.4	5.3
	-10.0	1.4	1.4	1.3	1.3		-10.0	6.6	6.5	6.3	6.2
	-5.0	1.6	1.6	1.5	1.3		-5.0	7.5	7.4	7.2	6.3
	0.0	1.8	1.8	1.5	1.3		0.0	8.5	8.4	7.2	6.3
	2.5	1.9	1.9	1.5	1.3		2.5	9.0	8.9	7.2	6.3
	6.0	2.0	1.9	1.5	1.3		6.0	9.3	9.0	7.2	6.3
	7.5	2.0	1.9	1.5	1.3		7.5	9.7	9.0	7.2	6.3
	10.0	2.2	1.9	1.5	1.3		10.0	10.3	9.0	7.2	6.3
	12.5	2.3	1.9	1.5	1.3		12.5	10.8	9.0	7.2	6.3
15.5	2.4	1.9	1.5	1.3	15.5	11.5	9.0	7.2	6.3		
20 (2.5)	-20.0	1.3	1.3	1.3	1.2	80 (10.0)	-20.0	5.1	5.0	5.0	5.0
	-15.0	1.6	1.5	1.5	1.5		-15.0	6.2	6.1	6.0	5.9
	-10.0	1.8	1.8	1.7	1.7		-10.0	7.3	7.2	7.0	6.8
	-5.0	2.1	2.1	2.0	1.8		-5.0	8.4	8.3	8.0	7.0
	0.0	2.4	2.3	2.0	1.8		0.0	9.5	9.4	8.0	7.0
	2.5	2.5	2.5	2.0	1.8		2.5	10.0	9.9	8.0	7.0
	6.0	2.6	2.5	2.0	1.8		6.0	10.4	10.0	8.0	7.0
	7.5	2.7	2.5	2.0	1.8		7.5	10.7	10.0	8.0	7.0
	10.0	2.8	2.5	2.0	1.8		10.0	11.4	10.0	8.0	7.0
	12.5	3.0	2.5	2.0	1.8		12.5	12.0	10.0	8.0	7.0
15.5	3.2	2.5	2.0	1.8	15.5	12.8	10.0	8.0	7.0		
25 (3.2)	-20.0	1.6	1.6	1.6	1.6	100 (12.5)	-20.0	6.4	6.3	6.3	6.2
	-15.0	2.0	2.0	1.9	1.9		-15.0	7.8	7.6	7.5	7.4
	-10.0	2.3	2.3	2.2	2.2		-10.0	9.1	9.0	8.7	8.6
	-5.0	2.7	2.6	2.6	2.2		-5.0	10.5	10.3	10.0	8.8
	0.0	3.0	3.0	2.6	2.2		0.0	11.8	11.7	10.0	8.8
	2.5	3.2	3.2	2.6	2.2		2.5	12.5	12.4	10.0	8.8
	6.0	3.3	3.2	2.6	2.2		6.0	12.9	12.5	10.0	8.8
	7.5	3.4	3.2	2.6	2.2		7.5	13.4	12.5	10.0	8.8
	10.0	3.6	3.2	2.6	2.2		10.0	14.2	12.5	10.0	8.8
	12.5	3.9	3.2	2.6	2.2		12.5	15.1	12.5	10.0	8.8
15.5	4.1	3.2	2.6	2.2	15.5	16.0	12.5	10.0	8.8		
32 (4.0)	-20.0	2.0	2.0	2.0	2.0	125 (16.0)	-20.0	8.2	8.0	8.0	7.9
	-15.0	2.5	2.4	2.4	2.4		-15.0	9.9	9.8	9.6	9.4
	-10.0	2.9	2.9	2.8	2.7		-10.0	11.7	11.5	11.2	11.0
	-5.0	3.3	3.3	3.2	2.8		-5.0	13.4	13.2	12.8	11.2
	0.0	3.8	3.7	3.2	2.8		0.0	15.1	15.0	12.8	11.2
	2.5	4.0	4.0	3.2	2.8		2.5	16.0	15.8	12.8	11.2
	6.0	4.1	4.0	3.2	2.8		6.0	16.6	16.0	12.8	11.2
	7.5	4.3	4.0	3.2	2.8		7.5	17.2	16.0	12.8	11.2
	10.0	4.6	4.0	3.2	2.8		10.0	18.2	16.0	12.8	11.2
	12.5	4.8	4.0	3.2	2.8		12.5	19.3	16.0	12.8	11.2
15.5	5.1	4.0	3.2	2.8	15.5	20.5	16.0	12.8	11.2		
40 (5.0)	-20.0	2.6	2.5	2.5	2.5	140 (18.0)	-20.0	9.2	9.0	9.0	8.9
	-15.0	3.1	3.1	3.0	3.0		-15.0	11.2	11.0	10.8	10.6
	-10.0	3.6	3.6	3.5	3.4		-10.0	13.1	12.9	12.6	12.3
	-5.0	4.2	4.1	4.0	3.5		-5.0	15.1	14.9	14.4	12.6
	0.0	4.7	4.7	4.0	3.5		0.0	17.0	16.8	14.4	12.6
	2.5	5.0	4.9	4.0	3.5		2.5	18.0	17.8	14.4	12.6
	6.0	5.2	5.0	4.0	3.5		6.0	18.6	18.0	14.4	12.6
	7.5	5.4	5.0	4.0	3.5		7.5	19.3	18.0	14.4	12.6
	10.0	5.7	5.0	4.0	3.5		10.0	20.5	18.0	14.4	12.6
	12.5	6.0	5.0	4.0	3.5		12.5	21.7	18.0	14.4	12.6
15.5	6.4	5.0	4.0	3.5	15.5	23.1	18.0	14.4	12.6		
50 (6.3)	-20.0	3.2	3.2	3.2	3.1	200 (25.0)	-20.0	12.8	12.6	12.5	12.4
	-15.0	3.9	3.8	3.8	3.7		-15.0	15.5	15.3	15.0	14.8
	-10.0	4.6	4.5	4.4	4.3		-10.0	18.2	18.0	17.5	17.1
	-5.0	5.3	5.2	5.0	4.4		-5.0	20.9	20.7	20.0	17.5
	0.0	6.0	5.9	5.0	4.4		0.0	23.6	23.4	20.0	17.5
	2.5	6.3	6.2	5.0	4.4		2.5	25.0	24.7	20.0	17.5
	6.0	6.5	6.3	5.0	4.4		6.0	25.9	25.0	20.0	17.5
	7.5	6.8	6.3	5.0	4.4		7.5	26.9	25.0	20.0	17.5
	10.0	7.2	6.3	5.0	4.4		10.0	28.5	25.0	20.0	17.5
	12.5	7.6	6.3	5.0	4.4		12.5	30.1	25.0	20.0	17.5
15.5	8.1	6.3	5.0	4.4	15.5	32.1	25.0	20.0	17.5		
63 (8.0)	-20.0	4.1	4.0	4.0	4.0	250 (31.5)	-20.0	16.1	15.8	15.8	15.6
	-15.0	5.0	4.9	4.8	4.7		-15.0	19.5	19.2	18.9	18.6
	-10.0	5.8	5.7	5.6	5.5		-10.0	22.9	22.6	22.0	21.6
	-5.0	6.7	6.6	6.4	5.6		-5.0	26.4	26.0	25.2	22.1
	0.0	7.6	7.5	6.4	5.6		0.0	29.8	29.5	25.2	22.1
	2.5	8.0	7.9	6.4	5.6		2.5	31.5	31.2	25.2	22.1
	6.0	8.3	8.0	6.4	5.6		6.0	32.6	31.5	25.2	22.1
	7.5	8.6	8.0	6.4	5.6		7.5	33.9	31.5	25.2	22.1
	10.0	9.1	8.0	6.4	5.6		10.0	35.9	31.5	25.2	22.1
	12.5	9.6	8.0	6.4	5.6		12.5	37.9	31.5	25.2	22.1
15.5	10.3	8.0	6.4	5.6	15.5	40.4	31.5	25.2	22.1		

kcal/h=kW x 860 , BTU/h = kW x 3,412

kcal/h=kW x 860 , BTU/h = kW x 3,412

9. Heating [All indoor units]

9-7. Heating capacity with PUHY-RP300-400Y(S)JM,PURY-RP300YJM "COP priority mode"

All Indoor units						All Indoor units					
Model size (Rated kW)	Outdoor air temp. °C W.B.	SHC:Sensible Heat Capacity(kW)				Model size (Rated kW)	Outdoor air temp. °C W.B.	SHC:Sensible Heat Capacity(kW)			
		Indoor air temp.						Indoor air temp.			
		15°C D.B.	20°C D.B.	25°C D.B.	27°C D.B.			15°C D.B.	20°C D.B.	25°C D.B.	27°C D.B.
		SHC	SHC	SHC	SHC		SHC	SHC	SHC	SHC	
15 (1.9)	-20.0	0.9	1.0	1.0	0.9	71 (9.0)	-20.0	4.5	4.5	4.6	4.4
	-15.0	1.1	1.1	1.1	1.1		-15.0	5.4	5.4	5.4	5.2
	-10.0	1.3	1.3	1.3	1.2		-10.0	6.3	6.2	6.2	5.8
	-5.0	1.5	1.5	1.4	1.2		-5.0	7.2	7.1	6.7	5.8
	0.0	1.7	1.7	1.4	1.2		0.0	8.1	8.0	6.7	5.8
	2.5	1.8	1.8	1.4	1.2		2.5	8.6	8.4	6.7	5.8
	6.0	1.9	1.9	1.4	1.2		6.0	9.2	9.0	6.7	5.8
	7.5	2.0	1.9	1.4	1.2		7.5	9.5	9.0	6.7	5.8
	10.0	2.1	1.9	1.4	1.2		10.0	9.9	9.0	6.7	5.8
	12.5	2.2	1.9	1.4	1.2		12.5	10.3	9.0	6.7	5.8
15.5	2.2	1.9	1.4	1.2	15.5	10.3	9.0	6.7	5.8		
20 (2.5)	-20.0	1.2	1.3	1.3	1.2	80 (10.0)	-20.0	5.0	5.0	5.1	4.9
	-15.0	1.5	1.5	1.5	1.5		-15.0	6.0	6.0	6.0	5.8
	-10.0	1.8	1.7	1.7	1.6		-10.0	7.0	6.9	6.8	6.4
	-5.0	2.0	2.0	1.9	1.6		-5.0	8.0	7.9	7.4	6.4
	0.0	2.3	2.2	1.9	1.6		0.0	9.0	8.9	7.5	6.4
	2.5	2.4	2.3	1.9	1.6		2.5	9.5	9.3	7.5	6.4
	6.0	2.6	2.5	1.9	1.6		6.0	10.2	10.0	7.5	6.4
	7.5	2.6	2.5	1.9	1.6		7.5	10.5	10.0	7.5	6.4
	10.0	2.8	2.5	1.9	1.6		10.0	11.0	10.0	7.5	6.4
	12.5	2.9	2.5	1.9	1.6		12.5	11.5	10.0	7.5	6.4
15.5	2.9	2.5	1.9	1.6	15.5	11.5	10.0	7.5	6.4		
25 (3.2)	-20.0	1.6	1.6	1.6	1.6	100 (12.5)	-20.0	6.2	6.3	6.4	6.1
	-15.0	1.9	1.9	1.9	1.9		-15.0	7.5	7.5	7.5	7.3
	-10.0	2.2	2.2	2.2	2.0		-10.0	8.8	8.7	8.6	8.0
	-5.0	2.6	2.5	2.4	2.0		-5.0	10.0	9.9	9.3	8.0
	0.0	2.9	2.8	2.4	2.0		0.0	11.3	11.1	9.3	8.0
	2.5	3.1	3.0	2.4	2.0		2.5	11.9	11.7	9.3	8.0
	6.0	3.3	3.2	2.4	2.0		6.0	12.8	12.5	9.3	8.0
	7.5	3.4	3.2	2.4	2.0		7.5	13.2	12.5	9.3	8.0
	10.0	3.5	3.2	2.4	2.0		10.0	13.8	12.5	9.3	8.0
	12.5	3.7	3.2	2.4	2.0		12.5	14.3	12.5	9.3	8.0
15.5	3.7	3.2	2.4	2.0	15.5	14.3	12.5	9.3	8.0		
32 (4.0)	-20.0	2.0	2.0	2.0	2.0	125 (16.0)	-20.0	8.0	8.0	8.2	7.8
	-15.0	2.4	2.4	2.4	2.3		-15.0	9.6	9.6	9.6	9.3
	-10.0	2.8	2.8	2.7	2.6		-10.0	11.2	11.1	10.9	10.2
	-5.0	3.2	3.2	3.0	2.6		-5.0	12.8	12.6	11.9	10.2
	0.0	3.6	3.5	3.0	2.6		0.0	14.4	14.2	11.9	10.2
	2.5	3.8	3.7	3.0	2.6		2.5	15.3	14.9	11.9	10.2
	6.0	4.1	4.0	3.0	2.6		6.0	16.4	16.0	11.9	10.2
	7.5	4.2	4.0	3.0	2.6		7.5	16.9	16.0	11.9	10.2
	10.0	4.4	4.0	3.0	2.6		10.0	17.7	16.0	11.9	10.2
	12.5	4.6	4.0	3.0	2.6		12.5	18.3	16.0	11.9	10.2
15.5	4.6	4.0	3.0	2.6	15.5	18.3	16.0	12.0	10.2		
40 (5.0)	-20.0	2.5	2.5	2.6	2.4	140 (18.0)	-20.0	9.0	9.1	9.2	8.8
	-15.0	3.0	3.0	3.0	2.9		-15.0	10.8	10.8	10.8	10.5
	-10.0	3.5	3.5	3.4	3.2		-10.0	12.6	12.5	12.3	11.5
	-5.0	4.0	3.9	3.7	3.2		-5.0	14.4	14.2	13.4	11.5
	0.0	4.5	4.4	3.7	3.2		0.0	16.3	15.9	13.4	11.5
	2.5	4.8	4.7	3.7	3.2		2.5	17.2	16.8	13.4	11.5
	6.0	5.1	5.0	3.7	3.2		6.0	18.4	18.0	13.4	11.5
	7.5	5.3	5.0	3.7	3.2		7.5	19.0	18.0	13.4	11.5
	10.0	5.5	5.0	3.7	3.2		10.0	19.9	18.0	13.4	11.5
	12.5	5.7	5.0	3.7	3.2		12.5	20.6	18.0	13.4	11.5
15.5	5.7	5.0	3.7	3.2	15.5	20.6	18.0	13.4	11.5		
50 (6.3)	-20.0	3.1	3.2	3.2	3.1	200 (25.0)	-20.0	12.5	12.6	12.8	12.2
	-15.0	3.8	3.8	3.8	3.7		-15.0	15.0	15.0	15.0	14.6
	-10.0	4.4	4.4	4.3	4.0		-10.0	17.5	17.4	17.1	16.0
	-5.0	5.1	5.0	4.7	4.0		-5.0	20.0	19.7	18.6	16.0
	0.0	5.7	5.6	4.7	4.0		0.0	22.6	22.1	18.6	16.0
	2.5	6.0	5.9	4.7	4.0		2.5	23.8	23.3	18.6	16.0
	6.0	6.5	6.3	4.7	4.0		6.0	25.6	25.0	18.6	16.0
	7.5	6.6	6.3	4.7	4.0		7.5	26.4	25.0	18.7	16.0
	10.0	7.0	6.3	4.7	4.0		10.0	27.6	25.0	18.7	16.0
	12.5	7.2	6.3	4.7	4.0		12.5	28.6	25.0	18.7	16.0
15.5	7.2	6.3	4.7	4.0	15.5	28.6	25.0	18.7	16.0		
63 (8.0)	-20.0	4.0	4.0	4.1	3.9	250 (31.5)	-20.0	15.7	15.8	16.1	15.4
	-15.0	4.8	4.8	4.8	4.7		-15.0	18.9	18.9	18.8	18.4
	-10.0	5.6	5.6	5.5	5.1		-10.0	22.1	21.9	21.5	20.2
	-5.0	6.4	6.3	6.0	5.1		-5.0	25.3	24.9	23.5	20.2
	0.0	7.2	7.1	6.0	5.1		0.0	28.4	27.9	23.5	20.2
	2.5	7.6	7.5	6.0	5.1		2.5	30.0	29.4	23.5	20.2
	6.0	8.2	8.0	6.0	5.1		6.0	32.3	31.5	23.5	20.2
	7.5	8.4	8.0	6.0	5.1		7.5	33.2	31.5	23.5	20.2
	10.0	8.8	8.0	6.0	5.1		10.0	34.8	31.5	23.5	20.2
	12.5	9.2	8.0	6.0	5.1		12.5	36.1	31.5	23.5	20.2
15.5	9.2	8.0	6.0	5.1	15.5	36.1	31.5	23.5	20.2		

kcal/h=kW x 860 , BTU/h = kW x 3,412

kcal/h=kW x 860 , BTU/h = kW x 3,412

9. Heating [All indoor units]

9-8. Heating capacity with PUHY-RP450-650YSJM "COP priority mode"

All Indoor units		SHC:Sensible Heat Capacity(kW)				All Indoor units		SHC:Sensible Heat Capacity(kW)			
Model size (Rated kW)	Outdoor air temp. °C W.B.	Indoor air temp.				Model size (Rated kW)	Outdoor air temp. °C W.B.	Indoor air temp.			
		15°C D.B.	20°C D.B.	25°C D.B.	27°C D.B.			15°C D.B.	20°C D.B.	25°C D.B.	27°C D.B.
		SHC	SHC	SHC	SHC			SHC	SHC	SHC	SHC
15 (1.9)	-20.0	1.0	1.0	1.0	0.9	71 (9.0)	-20.0	4.8	4.6	4.6	4.5
	-15.0	1.2	1.2	1.1	1.1		-15.0	5.6	5.5	5.3	5.2
	-10.0	1.4	1.3	1.3	1.3		-10.0	6.5	6.4	6.1	6.0
	-5.0	1.6	1.5	1.5	1.3		-5.0	7.4	7.2	6.9	6.4
	0.0	1.7	1.7	1.5	1.3		0.0	8.2	8.1	7.1	6.4
	2.5	1.8	1.8	1.5	1.3		2.5	8.7	8.5	7.1	6.4
	6.0	2.0	1.9	1.5	1.3		6.0	9.3	9.0	7.1	6.4
	7.5	2.0	1.9	1.5	1.3		7.5	9.5	9.0	7.1	6.4
	10.0	2.1	1.9	1.5	1.3		10.0	10.0	9.0	7.1	6.4
	12.5	2.2	1.9	1.5	1.3		12.5	10.4	9.0	7.1	6.4
15.5	2.2	1.9	1.5	1.3	15.5	10.4	9.0	7.1	6.4		
20 (2.5)	-20.0	1.3	1.3	1.3	1.2	80 (10.0)	-20.0	5.3	5.1	5.1	5.0
	-15.0	1.6	1.5	1.5	1.5		-15.0	6.3	6.1	5.9	5.8
	-10.0	1.8	1.8	1.7	1.7		-10.0	7.2	7.1	6.8	6.6
	-5.0	2.0	2.0	1.9	1.8		-5.0	8.2	8.0	7.7	7.1
	0.0	2.3	2.2	2.0	1.8		0.0	9.1	9.0	7.9	7.1
	2.5	2.4	2.4	2.0	1.8		2.5	9.6	9.5	7.9	7.1
	6.0	2.6	2.5	2.0	1.8		6.0	10.3	10.0	7.9	7.1
	7.5	2.6	2.5	2.0	1.8		7.5	10.6	10.0	7.9	7.1
	10.0	2.8	2.5	2.0	1.8		10.0	11.1	10.0	7.9	7.1
	12.5	2.9	2.5	2.0	1.8		12.5	11.5	10.0	7.9	7.1
15.5	2.9	2.5	2.0	1.8	15.5	11.6	10.0	7.9	7.1		
25 (3.2)	-20.0	1.7	1.6	1.6	1.6	100 (12.5)	-20.0	6.6	6.4	6.4	6.2
	-15.0	2.0	2.0	1.9	1.9		-15.0	7.8	7.6	7.4	7.3
	-10.0	2.3	2.3	2.2	2.1		-10.0	9.0	8.8	8.5	8.3
	-5.0	2.6	2.6	2.4	2.3		-5.0	10.2	10.0	9.6	8.9
	0.0	2.9	2.9	2.5	2.3		0.0	11.4	11.2	9.9	8.9
	2.5	3.1	3.0	2.5	2.3		2.5	12.0	11.8	9.9	8.9
	6.0	3.3	3.2	2.5	2.3		6.0	12.9	12.5	9.9	8.9
	7.5	3.4	3.2	2.5	2.3		7.5	13.2	12.5	9.9	8.9
	10.0	3.5	3.2	2.5	2.3		10.0	13.8	12.5	9.9	8.9
	12.5	3.7	3.2	2.5	2.3		12.5	14.4	12.5	9.9	8.9
15.5	3.7	3.2	2.5	2.3	15.5	14.5	12.5	9.9	8.9		
32 (4.0)	-20.0	2.1	2.1	2.0	2.0	125 (16.0)	-20.0	8.5	8.2	8.1	8.0
	-15.0	2.5	2.4	2.4	2.3		-15.0	10.0	9.8	9.5	9.3
	-10.0	2.9	2.8	2.7	2.6		-10.0	11.5	11.3	10.9	10.6
	-5.0	3.3	3.2	3.1	2.8		-5.0	13.1	12.8	12.2	11.3
	0.0	3.7	3.6	3.2	2.8		0.0	14.6	14.4	12.7	11.3
	2.5	3.8	3.8	3.2	2.8		2.5	15.4	15.1	12.7	11.3
	6.0	4.1	4.0	3.2	2.8		6.0	16.5	16.0	12.7	11.3
	7.5	4.2	4.0	3.2	2.8		7.5	16.9	16.0	12.7	11.3
	10.0	4.4	4.0	3.2	2.8		10.0	17.7	16.0	12.7	11.3
	12.5	4.6	4.0	3.2	2.8		12.5	18.5	16.0	12.7	11.3
15.5	4.6	4.0	3.2	2.8	15.5	18.5	16.0	12.7	11.3		
40 (5.0)	-20.0	2.6	2.6	2.5	2.5	140 (18.0)	-20.0	9.5	9.3	9.1	9.0
	-15.0	3.1	3.1	3.0	2.9		-15.0	11.3	11.0	10.7	10.4
	-10.0	3.6	3.5	3.4	3.3		-10.0	13.0	12.7	12.2	11.9
	-5.0	4.1	4.0	3.8	3.5		-5.0	14.7	14.4	13.8	12.8
	0.0	4.6	4.5	4.0	3.5		0.0	16.4	16.1	14.3	12.8
	2.5	4.8	4.7	4.0	3.5		2.5	17.3	17.0	14.3	12.8
	6.0	5.1	5.0	4.0	3.5		6.0	18.5	18.0	14.3	12.8
	7.5	5.3	5.0	4.0	3.5		7.5	19.0	18.0	14.3	12.8
	10.0	5.5	5.0	4.0	3.5		10.0	19.9	18.0	14.3	12.8
	12.5	5.8	5.0	4.0	3.5		12.5	20.8	18.0	14.3	12.8
15.5	5.8	5.0	4.0	3.5	15.5	20.8	18.0	14.3	12.8		
50 (6.3)	-20.0	3.3	3.2	3.2	3.1	200 (25.0)	-20.0	13.2	12.9	12.7	12.5
	-15.0	3.9	3.8	3.7	3.7		-15.0	15.6	15.3	14.9	14.5
	-10.0	4.5	4.4	4.3	4.2		-10.0	18.0	17.6	17.0	16.5
	-5.0	5.1	5.0	4.8	4.5		-5.0	20.4	20.0	19.1	17.7
	0.0	5.8	5.7	5.0	4.5		0.0	22.8	22.4	19.8	17.7
	2.5	6.1	6.0	5.0	4.5		2.5	24.0	23.6	19.8	17.7
	6.0	6.5	6.3	5.0	4.5		6.0	25.7	25.0	19.8	17.7
	7.5	6.7	6.3	5.0	4.5		7.5	26.4	25.0	19.8	17.7
	10.0	7.0	6.3	5.0	4.5		10.0	27.6	25.0	19.8	17.7
	12.5	7.3	6.3	5.0	4.5		12.5	28.9	25.0	19.8	17.7
15.5	7.3	6.3	5.0	4.5	15.5	28.9	25.0	19.8	17.7		
63 (8.0)	-20.0	4.2	4.1	4.1	4.0	250 (31.5)	-20.0	16.7	16.2	16.0	15.7
	-15.0	5.0	4.9	4.8	4.6		-15.0	19.7	19.2	18.7	18.3
	-10.0	5.8	5.6	5.4	5.3		-10.0	22.7	22.2	21.4	20.8
	-5.0	6.5	6.4	6.1	5.7		-5.0	25.7	25.2	24.1	22.3
	0.0	7.3	7.2	6.3	5.7		0.0	28.8	28.3	25.0	22.3
	2.5	7.7	7.6	6.3	5.7		2.5	30.3	29.8	25.0	22.3
	6.0	8.2	8.0	6.3	5.7		6.0	32.4	31.5	25.0	22.3
	7.5	8.5	8.0	6.3	5.7		7.5	33.3	31.5	25.0	22.3
	10.0	8.8	8.0	6.3	5.7		10.0	34.8	31.5	25.0	22.3
	12.5	9.2	8.0	6.3	5.7		12.5	36.4	31.5	25.0	22.3
15.5	9.3	8.0	6.3	5.7	15.5	36.5	31.5	24.9	22.3		

kcal/h=kW x 860 , BTU/h = kW x 3,412

kcal/h=kW x 860 , BTU/h = kW x 3,412

9. Heating [All indoor units]

9-9. Heating capacity with PUHY-RP700-800YSJM "COP priority mode"

All Indoor units		SHC:Sensible Heat Capacity(kW)				All Indoor units		SHC:Sensible Heat Capacity(kW)			
Model size (Rated kW)	Outdoor air temp. °C W.B.	Indoor air temp.				Model size (Rated kW)	Outdoor air temp. °C W.B.	Indoor air temp.			
		15°C D.B.	20°C D.B.	25°C D.B.	27°C D.B.			15°C D.B.	20°C D.B.	25°C D.B.	27°C D.B.
		SHC	SHC	SHC	SHC			SHC	SHC	SHC	SHC
15 (1.9)	-20.0	1.0	1.0	1.0	0.9	71 (9.0)	-20.0	4.6	4.5	4.5	4.4
	-15.0	1.2	1.1	1.1	1.1		-15.0	5.5	5.4	5.3	5.2
	-10.0	1.3	1.3	1.3	1.3		-10.0	6.4	6.3	6.1	6.0
	-5.0	1.5	1.5	1.5	1.4		-5.0	7.3	7.1	6.9	6.6
	0.0	1.7	1.7	1.5	1.4		0.0	8.2	8.0	7.1	6.6
	2.5	1.8	1.8	1.5	1.4		2.5	8.6	8.4	7.1	6.6
	6.0	1.9	1.9	1.5	1.4		6.0	9.2	9.0	7.1	6.6
	7.5	2.0	1.9	1.5	1.4		7.5	9.5	9.0	7.1	6.6
	10.0	2.1	1.9	1.5	1.4		10.0	9.9	9.0	7.1	6.6
	12.5	2.2	1.9	1.5	1.4		12.5	10.4	9.0	7.1	6.6
15.5	2.2	1.9	1.5	1.4	15.5	10.4	9.0	7.1	6.6		
20 (2.5)	-20.0	1.3	1.3	1.3	1.2	80 (10.0)	-20.0	5.1	5.0	5.0	4.9
	-15.0	1.5	1.5	1.5	1.5		-15.0	6.1	6.0	5.9	5.8
	-10.0	1.8	1.7	1.7	1.7		-10.0	7.1	7.0	6.8	6.7
	-5.0	2.0	2.0	1.9	1.8		-5.0	8.1	7.9	7.7	7.3
	0.0	2.3	2.2	2.0	1.8		0.0	9.1	8.9	7.9	7.3
	2.5	2.4	2.3	2.0	1.8		2.5	9.6	9.4	7.9	7.3
	6.0	2.6	2.5	2.0	1.8		6.0	10.3	10.0	7.9	7.3
	7.5	2.6	2.5	2.0	1.8		7.5	10.6	10.0	7.9	7.3
	10.0	2.8	2.5	2.0	1.8		10.0	11.1	10.0	7.9	7.3
	12.5	2.9	2.5	2.0	1.8		12.5	11.5	10.0	7.9	7.3
15.5	2.9	2.5	2.0	1.8	15.5	11.6	10.0	7.9	7.3		
25 (3.2)	-20.0	1.6	1.6	1.6	1.6	100 (12.5)	-20.0	6.4	6.3	6.3	6.2
	-15.0	1.9	1.9	1.9	1.9		-15.0	7.6	7.5	7.4	7.3
	-10.0	2.3	2.2	2.2	2.1		-10.0	8.9	8.7	8.5	8.3
	-5.0	2.6	2.5	2.5	2.4		-5.0	10.1	9.9	9.6	9.2
	0.0	2.9	2.8	2.5	2.4		0.0	11.3	11.1	9.9	9.2
	2.5	3.1	3.0	2.5	2.4		2.5	12.0	11.7	9.9	9.2
	6.0	3.3	3.2	2.5	2.3		6.0	12.8	12.5	9.9	9.2
	7.5	3.4	3.2	2.5	2.3		7.5	13.2	12.5	9.9	9.2
	10.0	3.5	3.2	2.5	2.3		10.0	13.8	12.5	9.9	9.2
	12.5	3.7	3.2	2.5	2.3		12.5	14.4	12.5	9.9	9.2
15.5	3.7	3.2	2.5	2.3	15.5	14.4	12.5	9.9	9.2		
32 (4.0)	-20.0	2.0	2.0	2.0	2.0	125 (16.0)	-20.0	8.2	8.0	8.1	7.9
	-15.0	2.4	2.4	2.4	2.3		-15.0	9.7	9.6	9.5	9.3
	-10.0	2.8	2.8	2.7	2.7		-10.0	11.3	11.1	10.9	10.7
	-5.0	3.2	3.2	3.1	2.9		-5.0	12.9	12.7	12.3	11.8
	0.0	3.6	3.6	3.2	2.9		0.0	14.5	14.2	12.7	11.8
	2.5	3.8	3.8	3.2	2.9		2.5	15.3	15.0	12.7	11.8
	6.0	4.1	4.0	3.2	2.9		6.0	16.4	16.0	12.7	11.7
	7.5	4.2	4.0	3.2	2.9		7.5	16.9	16.0	12.7	11.7
	10.0	4.4	4.0	3.2	2.9		10.0	17.7	16.0	12.7	11.7
	12.5	4.6	4.0	3.2	2.9		12.5	18.4	16.0	12.7	11.7
15.5	4.6	4.0	3.2	2.9	15.5	18.5	16.0	12.7	11.7		
40 (5.0)	-20.0	2.6	2.5	2.5	2.5	140 (18.0)	-20.0	9.2	9.1	9.1	8.9
	-15.0	3.0	3.0	3.0	2.9		-15.0	11.0	10.8	10.7	10.4
	-10.0	3.5	3.5	3.4	3.3		-10.0	12.7	12.5	12.2	12.0
	-5.0	4.0	4.0	3.8	3.7		-5.0	14.5	14.3	13.8	13.2
	0.0	4.5	4.5	4.0	3.7		0.0	16.3	16.0	14.3	13.2
	2.5	4.8	4.7	4.0	3.7		2.5	17.2	16.9	14.3	13.2
	6.0	5.1	5.0	4.0	3.7		6.0	18.5	18.0	14.3	13.2
	7.5	5.3	5.0	4.0	3.7		7.5	19.0	18.0	14.3	13.2
	10.0	5.5	5.0	4.0	3.7		10.0	19.9	18.0	14.3	13.2
	12.5	5.8	5.0	4.0	3.7		12.5	20.7	18.0	14.3	13.2
15.5	5.8	5.0	4.0	3.7	15.5	20.8	18.0	14.3	13.2		
50 (6.3)	-20.0	3.2	3.2	3.2	3.1	200 (25.0)	-20.0	12.8	12.6	12.6	12.4
	-15.0	3.8	3.8	3.7	3.7		-15.0	15.2	15.0	14.8	14.5
	-10.0	4.5	4.4	4.3	4.2		-10.0	17.7	17.4	17.0	16.6
	-5.0	5.1	5.0	4.8	4.6		-5.0	20.2	19.8	19.2	18.4
	0.0	5.7	5.6	5.0	4.6		0.0	22.7	22.3	19.8	18.4
	2.5	6.0	5.9	5.0	4.6		2.5	23.9	23.5	19.8	18.4
	6.0	6.5	6.3	5.0	4.6		6.0	25.6	25.0	19.8	18.4
	7.5	6.7	6.3	5.0	4.6		7.5	26.4	25.0	19.8	18.4
	10.0	7.0	6.3	5.0	4.6		10.0	27.6	25.0	19.8	18.4
	12.5	7.3	6.3	5.0	4.6		12.5	28.8	25.0	19.8	18.4
15.5	7.3	6.3	5.0	4.6	15.5	28.9	25.0	19.8	18.3		
63 (8.0)	-20.0	4.1	4.0	4.0	4.0	250 (31.5)	-20.0	16.1	15.8	15.9	15.6
	-15.0	4.9	4.8	4.7	4.6		-15.0	19.2	18.9	18.6	18.3
	-10.0	5.7	5.6	5.4	5.3		-10.0	22.3	21.9	21.4	21.0
	-5.0	6.5	6.3	6.1	5.9		-5.0	25.4	25.0	24.2	23.1
	0.0	7.3	7.1	6.3	5.9		0.0	28.6	28.0	25.0	23.1
	2.5	7.7	7.5	6.3	5.9		2.5	30.1	29.6	25.0	23.1
	6.0	8.2	8.0	6.3	5.9		6.0	32.3	31.5	25.0	23.1
	7.5	8.4	8.0	6.3	5.9		7.5	33.3	31.5	25.0	23.1
	10.0	8.8	8.0	6.3	5.9		10.0	34.8	31.5	25.0	23.1
	12.5	9.2	8.0	6.3	5.9		12.5	36.3	31.5	25.0	23.1
15.5	9.2	8.0	6.3	5.9	15.5	36.4	31.5	25.0	23.1		

kcal/h=kW x 860 , BTU/h = kW x 3,412

kcal/h=kW x 860 , BTU/h = kW x 3,412

9. Heating [All indoor units]

9-10. Heating capacity with PUHY-RP850-900YSJM "COP priority mode"

All Indoor units		SHC:Sensible Heat Capacity(kW)				All Indoor units		SHC:Sensible Heat Capacity(kW)			
Model size (Rated kW)	Outdoor air temp. °C W.B.	Indoor air temp.				Model size (Rated kW)	Outdoor air temp. °C W.B.	Indoor air temp.			
		15°C D.B.	20°C D.B.	25°C D.B.	27°C D.B.			15°C D.B.	20°C D.B.	25°C D.B.	27°C D.B.
		SHC	SHC	SHC	SHC			SHC	SHC	SHC	SHC
15 (1.9)	-20.0	1.0	1.0	1.0	0.9	71 (9.0)	-20.0	4.8	4.6	4.6	4.5
	-15.0	1.2	1.2	1.1	1.1		-15.0	5.6	5.5	5.3	5.2
	-10.0	1.4	1.3	1.3	1.3		-10.0	6.5	6.4	6.1	6.0
	-5.0	1.6	1.5	1.5	1.3		-5.0	7.4	7.2	6.9	6.4
	0.0	1.7	1.7	1.5	1.3		0.0	8.2	8.1	7.1	6.4
	2.5	1.8	1.8	1.5	1.3		2.5	8.7	8.5	7.1	6.4
	6.0	2.0	1.9	1.5	1.3		6.0	9.3	9.0	7.1	6.4
	7.5	2.0	1.9	1.5	1.3		7.5	9.5	9.0	7.1	6.4
	10.0	2.1	1.9	1.5	1.3		10.0	10.0	9.0	7.1	6.4
	12.5	2.2	1.9	1.5	1.3		12.5	10.4	9.0	7.1	6.4
15.5	2.2	1.9	1.5	1.3	15.5	10.4	9.0	7.1	6.4		
20 (2.5)	-20.0	1.3	1.3	1.3	1.2	80 (10.0)	-20.0	5.3	5.1	5.1	5.0
	-15.0	1.6	1.5	1.5	1.5		-15.0	6.3	6.1	5.9	5.8
	-10.0	1.8	1.8	1.7	1.7		-10.0	7.2	7.1	6.8	6.6
	-5.0	2.0	2.0	1.9	1.8		-5.0	8.2	8.0	7.7	7.1
	0.0	2.3	2.2	2.0	1.8		0.0	9.1	9.0	7.9	7.1
	2.5	2.4	2.4	2.0	1.8		2.5	9.6	9.5	7.9	7.1
	6.0	2.6	2.5	2.0	1.8		6.0	10.3	10.0	7.9	7.1
	7.5	2.6	2.5	2.0	1.8		7.5	10.6	10.0	7.9	7.1
	10.0	2.8	2.5	2.0	1.8		10.0	11.1	10.0	7.9	7.1
	12.5	2.9	2.5	2.0	1.8		12.5	11.5	10.0	7.9	7.1
15.5	2.9	2.5	2.0	1.8	15.5	11.6	10.0	7.9	7.1		
25 (3.2)	-20.0	1.7	1.6	1.6	1.6	100 (12.5)	-20.0	6.6	6.4	6.4	6.2
	-15.0	2.0	2.0	1.9	1.9		-15.0	7.8	7.6	7.4	7.3
	-10.0	2.3	2.3	2.2	2.1		-10.0	9.0	8.8	8.5	8.3
	-5.0	2.6	2.6	2.4	2.3		-5.0	10.2	10.0	9.6	8.9
	0.0	2.9	2.9	2.5	2.3		0.0	11.4	11.2	9.9	8.9
	2.5	3.1	3.0	2.5	2.3		2.5	12.0	11.8	9.9	8.9
	6.0	3.3	3.2	2.5	2.3		6.0	12.9	12.5	9.9	8.9
	7.5	3.4	3.2	2.5	2.3		7.5	13.2	12.5	9.9	8.9
	10.0	3.5	3.2	2.5	2.3		10.0	13.8	12.5	9.9	8.9
	12.5	3.7	3.2	2.5	2.3		12.5	14.4	12.5	9.9	8.9
15.5	3.7	3.2	2.5	2.3	15.5	14.5	12.5	9.9	8.9		
32 (4.0)	-20.0	2.1	2.1	2.0	2.0	125 (16.0)	-20.0	8.5	8.2	8.1	8.0
	-15.0	2.5	2.4	2.4	2.3		-15.0	10.0	9.8	9.5	9.3
	-10.0	2.9	2.8	2.7	2.6		-10.0	11.5	11.3	10.9	10.6
	-5.0	3.3	3.2	3.1	2.8		-5.0	13.1	12.8	12.2	11.3
	0.0	3.7	3.6	3.2	2.8		0.0	14.6	14.4	12.7	11.3
	2.5	3.8	3.8	3.2	2.8		2.5	15.4	15.1	12.7	11.3
	6.0	4.1	4.0	3.2	2.8		6.0	16.5	16.0	12.7	11.3
	7.5	4.2	4.0	3.2	2.8		7.5	16.9	16.0	12.7	11.3
	10.0	4.4	4.0	3.2	2.8		10.0	17.7	16.0	12.7	11.3
	12.5	4.6	4.0	3.2	2.8		12.5	18.5	16.0	12.7	11.3
15.5	4.6	4.0	3.2	2.8	15.5	18.5	16.0	12.7	11.3		
40 (5.0)	-20.0	2.6	2.6	2.5	2.5	140 (18.0)	-20.0	9.5	9.3	9.1	9.0
	-15.0	3.1	3.1	3.0	2.9		-15.0	11.3	11.0	10.7	10.4
	-10.0	3.6	3.5	3.4	3.3		-10.0	13.0	12.7	12.2	11.9
	-5.0	4.1	4.0	3.8	3.5		-5.0	14.7	14.4	13.8	12.8
	0.0	4.6	4.5	4.0	3.5		0.0	16.4	16.1	14.3	12.8
	2.5	4.8	4.7	4.0	3.5		2.5	17.3	17.0	14.3	12.8
	6.0	5.1	5.0	4.0	3.5		6.0	18.5	18.0	14.3	12.8
	7.5	5.3	5.0	4.0	3.5		7.5	19.0	18.0	14.3	12.8
	10.0	5.5	5.0	4.0	3.5		10.0	19.9	18.0	14.3	12.8
	12.5	5.8	5.0	4.0	3.5		12.5	20.8	18.0	14.3	12.8
15.5	5.8	5.0	4.0	3.5	15.5	20.8	18.0	14.3	12.8		
50 (6.3)	-20.0	3.3	3.2	3.2	3.1	200 (25.0)	-20.0	13.2	12.9	12.7	12.5
	-15.0	3.9	3.8	3.7	3.7		-15.0	15.6	15.3	14.9	14.5
	-10.0	4.5	4.4	4.3	4.2		-10.0	18.0	17.6	17.0	16.5
	-5.0	5.1	5.0	4.8	4.5		-5.0	20.4	20.0	19.1	17.7
	0.0	5.8	5.7	5.0	4.5		0.0	22.8	22.4	19.8	17.7
	2.5	6.1	6.0	5.0	4.5		2.5	24.0	23.6	19.8	17.7
	6.0	6.5	6.3	5.0	4.5		6.0	25.7	25.0	19.8	17.7
	7.5	6.7	6.3	5.0	4.5		7.5	26.4	25.0	19.8	17.7
	10.0	7.0	6.3	5.0	4.5		10.0	27.6	25.0	19.8	17.7
	12.5	7.3	6.3	5.0	4.5		12.5	28.9	25.0	19.8	17.7
15.5	7.3	6.3	5.0	4.5	15.5	28.9	25.0	19.8	17.7		
63 (8.0)	-20.0	4.2	4.1	4.1	4.0	250 (31.5)	-20.0	16.7	16.2	16.0	15.7
	-15.0	5.0	4.9	4.8	4.6		-15.0	19.7	19.2	18.7	18.3
	-10.0	5.8	5.6	5.4	5.3		-10.0	22.7	22.2	21.4	20.8
	-5.0	6.5	6.4	6.1	5.7		-5.0	25.7	25.2	24.1	22.3
	0.0	7.3	7.2	6.3	5.7		0.0	28.8	28.3	25.0	22.3
	2.5	7.7	7.6	6.3	5.7		2.5	30.3	29.8	25.0	22.3
	6.0	8.2	8.0	6.3	5.7		6.0	32.4	31.5	25.0	22.3
	7.5	8.5	8.0	6.3	5.7		7.5	33.3	31.5	25.0	22.3
	10.0	8.8	8.0	6.3	5.7		10.0	34.8	31.5	25.0	22.3
	12.5	9.2	8.0	6.3	5.7		12.5	36.4	31.5	25.0	22.3
15.5	9.3	8.0	6.3	5.7	15.5	36.5	31.5	24.9	22.3		

kcal/h=kW x 860 , BTU/h = kW x 3,412

kcal/h=kW x 860 , BTU/h = kW x 3,412

10. Cooling [Ceiling concealed (Fresh air intake)]

10-1. Cooling capacity

PEFY-P80VMH-E-F

CA:Capacity(kW) , SHC:Sensible Heat Capacity(kW)

Outdoor air temp.		59°F W.B. 15°C W.B.		63°F W.B. 17°C W.B.		68°F W.B. 20°C W.B.		73°F W.B. 23°C W.B.		79°F W.B. 26°C W.B.		82°F W.B. 28°C W.B.		86°F W.B. 30°C W.B.		90°F W.B. 32°C W.B.		95°F W.B. 35°C W.B.	
°F D.B.	°C D.B.	CA	SHC	CA	SHC	CA	SHC	CA	SHC	CA	SHC	CA	SHC	CA	SHC	CA	SHC	CA	SHC
70	21	4.4	3.0	5.3	2.9	-	-	-	-	-	-	-	-	-	-	-	-	-	-
73	23	4.4	3.4	5.3	3.3	6.5	3.0	-	-	-	-	-	-	-	-	-	-	-	-
77	25	4.4	3.8	5.2	3.7	6.4	3.4	-	-	-	-	-	-	-	-	-	-	-	-
81	27	-	-	5.2	4.0	6.4	3.7	7.5	3.3	-	-	-	-	-	-	-	-	-	-
84	29	-	-	-	-	6.4	4.1	7.5	3.7	8.5	3.2	-	-	-	-	-	-	-	-
88	31	-	-	-	-	6.3	4.5	7.4	4.0	8.4	3.5	9.1	3.1	-	-	-	-	-	-
91	33	-	-	-	-	-	-	7.3	4.4	8.3	3.8	9.0	3.5	9.6	3.0	-	-	-	-
95	35	-	-	-	-	-	-	7.2	4.7	8.2	4.2	8.9	3.8	9.5	3.3	-	-	-	-
99	37	-	-	-	-	-	-	-	-	8.1	4.5	8.8	4.1	9.4	3.7	9.9	3.2	-	-
104	40	-	-	-	-	-	-	-	-	8.0	5.0	8.6	4.6	9.1	4.1	9.7	3.7	10.5	2.9

PEFY-P140VMH-E-F

Outdoor air temp.		59°F W.B. 15°C W.B.		63°F W.B. 17°C W.B.		68°F W.B. 20°C W.B.		73°F W.B. 23°C W.B.		79°F W.B. 26°C W.B.		82°F W.B. 28°C W.B.		86°F W.B. 30°C W.B.		90°F W.B. 32°C W.B.		95°F W.B. 35°C W.B.	
°F D.B.	°C D.B.	CA	SHC	CA	SHC	CA	SHC	CA	SHC	CA	SHC	CA	SHC	CA	SHC	CA	SHC	CA	SHC
70	21	7.8	5.6	9.4	5.3	-	-	-	-	-	-	-	-	-	-	-	-	-	-
73	23	7.8	6.3	9.3	6.0	11.5	5.4	-	-	-	-	-	-	-	-	-	-	-	-
77	25	7.8	7.1	9.3	6.8	11.5	6.1	-	-	-	-	-	-	-	-	-	-	-	-
81	27	-	-	9.3	7.5	11.4	6.8	13.4	6.0	-	-	-	-	-	-	-	-	-	-
84	29	-	-	-	-	11.3	7.5	13.3	6.7	15.2	5.6	-	-	-	-	-	-	-	-
88	31	-	-	-	-	11.2	8.2	13.2	7.3	15.0	6.3	16.2	5.5	-	-	-	-	-	-
91	33	-	-	-	-	-	-	13.0	8.0	14.8	7.0	16.0	6.2	17.1	5.3	-	-	-	-
95	35	-	-	-	-	-	-	12.9	8.7	14.6	7.6	15.8	6.8	16.9	6.0	-	-	-	-
99	37	-	-	-	-	-	-	-	-	14.5	8.3	15.6	7.5	16.6	6.6	17.7	5.7	-	-
104	40	-	-	-	-	-	-	-	-	14.2	9.3	15.2	8.5	16.3	7.6	17.3	6.7	18.7	5.3

PEFY-P200VMH-E-F

Outdoor air temp.		59°F W.B. 15°C W.B.		63°F W.B. 17°C W.B.		68°F W.B. 20°C W.B.		73°F W.B. 23°C W.B.		79°F W.B. 26°C W.B.		82°F W.B. 28°C W.B.		86°F W.B. 30°C W.B.		90°F W.B. 32°C W.B.		95°F W.B. 35°C W.B.	
°F D.B.	°C D.B.	CA	SHC	CA	SHC	CA	SHC	CA	SHC	CA	SHC	CA	SHC	CA	SHC	CA	SHC	CA	SHC
70	21	10.9	7.9	13.1	7.5	-	-	-	-	-	-	-	-	-	-	-	-	-	-
73	23	11.0	9.0	13.1	8.5	16.1	7.6	-	-	-	-	-	-	-	-	-	-	-	-
77	25	11.0	10.1	13.0	9.6	16.0	8.6	-	-	-	-	-	-	-	-	-	-	-	-
81	27	-	-	13.0	10.7	15.9	9.7	18.8	8.4	-	-	-	-	-	-	-	-	-	-
84	29	-	-	-	-	15.8	10.7	18.6	9.4	21.2	7.9	-	-	-	-	-	-	-	-
88	31	-	-	-	-	15.7	11.7	18.4	10.4	21.0	8.9	22.6	7.7	-	-	-	-	-	-
91	33	-	-	-	-	-	-	18.2	11.4	20.7	9.8	22.4	8.7	23.9	7.5	-	-	-	-
95	35	-	-	-	-	-	-	18.0	12.4	20.5	10.8	22.1	9.6	23.6	8.4	-	-	-	-
99	37	-	-	-	-	-	-	-	-	20.2	11.8	21.8	10.6	23.3	9.4	24.7	8.1	-	-
104	40	-	-	-	-	-	-	-	-	19.8	13.2	21.3	12.0	22.8	10.8	24.2	9.5	26.2	7.47

PEFY-P250VMH-E-F

Outdoor air temp.		59°F W.B. 15°C W.B.		63°F W.B. 17°C W.B.		68°F W.B. 20°C W.B.		73°F W.B. 23°C W.B.		79°F W.B. 26°C W.B.		82°F W.B. 28°C W.B.		86°F W.B. 30°C W.B.		90°F W.B. 32°C W.B.		95°F W.B. 35°C W.B.	
°F D.B.	°C D.B.	CA	SHC	CA	SHC	CA	SHC	CA	SHC	CA	SHC	CA	SHC	CA	SHC	CA	SHC	CA	SHC
70	21	13.7	9.9	16.4	9.3	-	-	-	-	-	-	-	-	-	-	-	-	-	-
73	23	13.7	11.3	16.3	10.7	20.2	9.5	-	-	-	-	-	-	-	-	-	-	-	-
77	25	13.7	12.6	16.3	12.0	20.1	10.8	-	-	-	-	-	-	-	-	-	-	-	-
81	27	-	-	16.2	13.3	19.9	12.1	23.4	10.5	-	-	-	-	-	-	-	-	-	-
84	29	-	-	-	-	19.8	13.4	23.2	11.7	26.5	9.8	-	-	-	-	-	-	-	-
88	31	-	-	-	-	19.6	14.7	23.0	13.0	26.2	11.1	28.3	9.7	-	-	-	-	-	-
91	33	-	-	-	-	-	-	22.8	14.2	25.9	12.3	28.0	10.9	29.9	9.3	-	-	-	-
95	35	-	-	-	-	-	-	22.5	15.5	25.6	13.5	27.6	12.1	29.5	10.5	-	-	-	-
99	37	-	-	-	-	-	-	-	-	25.3	14.7	27.2	13.3	29.1	11.7	30.9	10.1	-	-
104	40	-	-	-	-	-	-	-	-	24.8	16.5	26.6	15.0	28.4	13.5	30.2	11.9	32.7	9.34

There are times when the cooling capacity is lowered to protect the compressor in cases where the outdoor air temperature exceeds 40°C (104°F)

10. Cooling [Ceiling concealed (Fresh air intake)]

10-2. Outlet air temp. cooled

PEFY-P80VMH-E-F

Outdoor air temp.		59°F W.B. 15°C W.B.		63°F W.B. 17°C W.B.		68°F W.B. 20°C W.B.		73°F W.B. 23°C W.B.		79°F W.B. 26°C W.B.		82°F W.B. 28°C W.B.		86°F W.B. 30°C W.B.		90°F W.B. 32°C W.B.		95°F W.B. 35°C W.B.	
°F D.B.	°C D.B.	°C D.B.	°C W.B.	°C D.B.	°C W.B.	°C D.B.	°C W.B.	°C D.B.	°C W.B.	°C D.B.	°C W.B.	°C D.B.	°C W.B.	°C D.B.	°C W.B.	°C D.B.	°C W.B.	°C D.B.	°C W.B.
70	21	5.1	5.0	5.6	5.6	-	-	-	-	-	-	-	-	-	-	-	-	-	-
73	23	5.1	5.0	5.7	5.6	7.0	7.0	-	-	-	-	-	-	-	-	-	-	-	-
77	25	5.1	5.0	5.7	5.7	7.1	7.1	-	-	-	-	-	-	-	-	-	-	-	-
81	27	-	-	5.8	5.7	7.2	7.2	9.2	9.2	-	-	-	-	-	-	-	-	-	-
84	29	-	-	-	-	7.4	7.3	9.4	9.4	12.0	12.0	-	-	-	-	-	-	-	-
88	31	-	-	-	-	7.5	7.4	9.6	9.6	12.2	12.2	14.2	14.2	-	-	-	-	-	-
91	33	-	-	-	-	-	-	9.8	9.7	12.4	12.4	14.4	14.4	16.6	16.6	-	-	-	-
95	35	-	-	-	-	-	-	10.0	9.9	12.6	12.6	14.6	14.6	16.8	16.8	-	-	-	-
99	37	-	-	-	-	-	-	-	-	12.8	12.8	14.9	14.8	17.1	17.1	19.5	19.5	-	-
104	40	-	-	-	-	-	-	-	-	13.2	13.1	15.3	15.2	17.5	17.4	19.9	19.8	23.7	23.7

PEFY-P140VMH-E-F

Outdoor air temp.		59°F W.B. 15°C W.B.		63°F W.B. 17°C W.B.		68°F W.B. 20°C W.B.		73°F W.B. 23°C W.B.		79°F W.B. 26°C W.B.		82°F W.B. 28°C W.B.		86°F W.B. 30°C W.B.		90°F W.B. 32°C W.B.		95°F W.B. 35°C W.B.	
°F D.B.	°C D.B.	°C D.B.	°C W.B.	°C D.B.	°C W.B.	°C D.B.	°C W.B.	°C D.B.	°C W.B.	°C D.B.	°C W.B.	°C D.B.	°C W.B.	°C D.B.	°C W.B.	°C D.B.	°C W.B.	°C D.B.	°C W.B.
70	21	6.3	6.3	7.1	7.0	-	-	-	-	-	-	-	-	-	-	-	-	-	-
73	23	6.3	6.3	7.1	7.1	8.7	8.7	-	-	-	-	-	-	-	-	-	-	-	-
77	25	6.4	6.3	7.2	7.1	8.8	8.8	-	-	-	-	-	-	-	-	-	-	-	-
81	27	-	-	7.2	7.1	8.9	8.9	11.1	11.1	-	-	-	-	-	-	-	-	-	-
84	29	-	-	-	-	9.0	9.0	11.2	11.2	13.9	13.9	-	-	-	-	-	-	-	-
88	31	-	-	-	-	9.1	9.0	11.4	11.3	14.0	14.0	16.1	16.1	-	-	-	-	-	-
91	33	-	-	-	-	-	-	11.5	11.5	14.2	14.2	16.2	16.2	18.4	18.4	-	-	-	-
95	35	-	-	-	-	-	-	11.7	11.6	14.4	14.4	16.4	16.4	18.6	18.6	-	-	-	-
99	37	-	-	-	-	-	-	-	-	14.6	14.5	16.7	16.6	18.8	18.8	21.2	21.1	-	-
104	40	-	-	-	-	-	-	-	-	14.9	14.8	17.0	16.9	19.2	19.1	21.5	21.5	25.2	25.2

PEFY-P200VMH-E-F

Outdoor air temp.		59°F W.B. 15°C W.B.		63°F W.B. 17°C W.B.		68°F W.B. 20°C W.B.		73°F W.B. 23°C W.B.		79°F W.B. 26°C W.B.		82°F W.B. 28°C W.B.		86°F W.B. 30°C W.B.		90°F W.B. 32°C W.B.		95°F W.B. 35°C W.B.	
°F D.B.	°C D.B.	°C D.B.	°C W.B.	°C D.B.	°C W.B.	°C D.B.	°C W.B.	°C D.B.	°C W.B.	°C D.B.	°C W.B.	°C D.B.	°C W.B.	°C D.B.	°C W.B.	°C D.B.	°C W.B.	°C D.B.	°C W.B.
70	21	7.6	7.2	8.3	8.2	-	-	-	-	-	-	-	-	-	-	-	-	-	-
73	23	7.7	7.2	8.5	8.2	10.0	10.0	-	-	-	-	-	-	-	-	-	-	-	-
77	25	7.8	7.2	8.6	8.2	10.3	10.1	-	-	-	-	-	-	-	-	-	-	-	-
81	27	-	-	8.8	8.2	10.5	10.1	12.5	12.4	-	-	-	-	-	-	-	-	-	-
84	29	-	-	-	-	10.7	10.2	12.8	12.6	15.3	15.3	-	-	-	-	-	-	-	-
88	31	-	-	-	-	10.9	10.3	13.0	12.7	15.6	15.4	17.5	17.5	-	-	-	-	-	-
91	33	-	-	-	-	-	-	13.3	12.8	15.9	15.6	17.7	17.6	19.8	19.8	-	-	-	-
95	35	-	-	-	-	-	-	13.6	12.9	16.1	15.7	18.1	17.8	20.1	20.0	-	-	-	-
99	37	-	-	-	-	-	-	-	-	16.4	15.9	18.4	17.9	20.4	20.1	22.6	22.4	-	-
104	40	-	-	-	-	-	-	-	-	16.9	16.1	18.8	18.2	20.9	20.4	23.1	22.7	26.5	26.3

PEFY-P250VMH-E-F

Outdoor air temp.		59°F W.B. 15°C W.B.		63°F W.B. 17°C W.B.		68°F W.B. 20°C W.B.		73°F W.B. 23°C W.B.		79°F W.B. 26°C W.B.		82°F W.B. 28°C W.B.		86°F W.B. 30°C W.B.		90°F W.B. 32°C W.B.		95°F W.B. 35°C W.B.	
°F D.B.	°C D.B.	°C D.B.	°C W.B.	°C D.B.	°C W.B.	°C D.B.	°C W.B.	°C D.B.	°C W.B.	°C D.B.	°C W.B.	°C D.B.	°C W.B.	°C D.B.	°C W.B.	°C D.B.	°C W.B.	°C D.B.	°C W.B.
70	21	7.6	7.2	8.3	8.2	-	-	-	-	-	-	-	-	-	-	-	-	-	-
73	23	7.7	7.2	8.5	8.2	10.0	10.0	-	-	-	-	-	-	-	-	-	-	-	-
77	25	7.8	7.2	8.6	8.2	10.3	10.1	-	-	-	-	-	-	-	-	-	-	-	-
81	27	-	-	8.8	8.2	10.5	10.1	12.5	12.4	-	-	-	-	-	-	-	-	-	-
84	29	-	-	-	-	10.7	10.2	12.8	12.6	15.3	15.3	-	-	-	-	-	-	-	-
88	31	-	-	-	-	10.9	10.3	13.0	12.7	15.6	15.4	17.5	17.5	-	-	-	-	-	-
91	33	-	-	-	-	-	-	13.3	12.8	15.9	15.6	17.7	17.6	19.8	19.8	-	-	-	-
95	35	-	-	-	-	-	-	13.6	12.9	16.1	15.7	18.1	17.8	20.1	20.0	-	-	-	-
99	37	-	-	-	-	-	-	-	-	16.4	15.9	18.4	17.9	20.4	20.1	22.6	22.4	-	-
104	40	-	-	-	-	-	-	-	-	16.9	16.1	18.8	18.2	20.9	20.4	23.1	22.7	26.5	26.3

11. Heating [Ceiling concealed (Fresh air intake)]

11-1. Heating capacity

PEFY-P80VMH-E-F

SHC:Sensible Heat Capacity(kW)

Outdoor air temp.		16°F W.B. -9°C W.B.	23°F W.B. -5°C W.B.	27°F W.B. -2.9°C W.B.	32°F W.B. 0°C W.B.	36°F W.B. 2°C W.B.	39°F W.B. 4°C W.B.	43°F W.B. 6°C W.B.	50°F W.B. 10°C W.B.	57°F W.B. 14°C W.B.
°F D.B.	°C D.B.	SHC	SHC	SHC	SHC	SHC	SHC	SHC	SHC	SHC
18	-8	8.2	-	-	-	-	-	-	-	-
27	-3	-	9.1	-	-	-	-	-	-	-
32	0	-	-	8.5	-	-	-	-	-	-
37	3	-	-	-	7.9	7.9	-	-	-	-
45	7	-	-	-	-	7.1	7.1	7.1	-	-
52	11	-	-	-	-	-	-	6.3	6.3	-
59	15	-	-	-	-	-	-	-	5.5	5.5
64	18	-	-	-	-	-	-	-	5.0	5.0
68	20	-	-	-	-	-	-	-	-	4.6

PEFY-P140VMH-E-F

Outdoor air temp.		16°F W.B. -9°C W.B.	23°F W.B. -5°C W.B.	27°F W.B. -2.9°C W.B.	32°F W.B. 0°C W.B.	36°F W.B. 2°C W.B.	39°F W.B. 4°C W.B.	43°F W.B. 6°C W.B.	50°F W.B. 10°C W.B.	57°F W.B. 14°C W.B.
°F D.B.	°C D.B.	SHC	SHC	SHC	SHC	SHC	SHC	SHC	SHC	SHC
18	-8	14.6	-	-	-	-	-	-	-	-
27	-3	-	16.2	-	-	-	-	-	-	-
32	0	-	-	15.1	-	-	-	-	-	-
37	3	-	-	-	14.0	14.0	-	-	-	-
45	7	-	-	-	-	12.6	12.6	12.6	-	-
52	11	-	-	-	-	-	-	11.2	11.2	-
59	15	-	-	-	-	-	-	-	9.8	9.8
64	18	-	-	-	-	-	-	-	8.8	8.8
68	20	-	-	-	-	-	-	-	-	8.1

PEFY-P200VMH-E-F

Outdoor air temp.		16°F W.B. -9°C W.B.	23°F W.B. -5°C W.B.	27°F W.B. -2.9°C W.B.	32°F W.B. 0°C W.B.	36°F W.B. 2°C W.B.	39°F W.B. 4°C W.B.	43°F W.B. 6°C W.B.	50°F W.B. 10°C W.B.	57°F W.B. 14°C W.B.
°F D.B.	°C D.B.	SHC	SHC	SHC	SHC	SHC	SHC	SHC	SHC	SHC
18	-8	20.5	-	-	-	-	-	-	-	-
27	-3	-	22.7	-	-	-	-	-	-	-
32	0	-	-	21.2	-	-	-	-	-	-
37	3	-	-	-	19.7	19.7	-	-	-	-
45	7	-	-	-	-	17.8	17.8	17.8	-	-
52	11	-	-	-	-	-	-	15.8	15.8	-
59	15	-	-	-	-	-	-	-	13.8	13.8
64	18	-	-	-	-	-	-	-	12.3	12.3
68	20	-	-	-	-	-	-	-	-	11.4

PEFY-P250VMH-E-F

Outdoor air temp.		16°F W.B. -9°C W.B.	23°F W.B. -5°C W.B.	27°F W.B. -2.9°C W.B.	32°F W.B. 0°C W.B.	36°F W.B. 2°C W.B.	39°F W.B. 4°C W.B.	43°F W.B. 6°C W.B.	50°F W.B. 10°C W.B.	57°F W.B. 14°C W.B.
°F D.B.	°C D.B.	SHC	SHC	SHC	SHC	SHC	SHC	SHC	SHC	SHC
18	-8	25.7	-	-	-	-	-	-	-	-
27	-3	-	28.3	-	-	-	-	-	-	-
32	0	-	-	26.5	-	-	-	-	-	-
37	3	-	-	-	24.7	24.7	-	-	-	-
45	7	-	-	-	-	22.2	22.2	22.2	-	-
52	11	-	-	-	-	-	-	19.7	19.7	-
59	15	-	-	-	-	-	-	-	17.3	17.3
64	18	-	-	-	-	-	-	-	15.4	15.4
68	20	-	-	-	-	-	-	-	-	14.2

11. Heating [Ceiling concealed (Fresh air intake)]

11-2. Outlet air temp. heated

PEFY-P80VMH-E-F

Outdoor air temp.		16°F W.B. -9°C W.B.	23°F W.B. -5°C W.B.	27°F W.B. -2.9°C W.B.	32°F W.B. 0°C W.B.	36°F W.B. 2°C W.B.	39°F W.B. 4°C W.B.	43°F W.B. 6°C W.B.	50°F W.B. 10°C W.B.	57°F W.B. 14°C W.B.
°F D.B.	°C D.B.	°C D.B.	°C D.B.	°C D.B.	°C D.B.	°C D.B.	°C D.B.	°C D.B.	°C D.B.	°C D.B.
18	-8	40.6	-	-	-	-	-	-	-	-
27	-3	-	53.1	-	-	-	-	-	-	-
32	0	-	-	51.9	-	-	-	-	-	-
37	3	-	-	-	51.3	51.8	-	-	-	-
45	7	-	-	-	-	50.5	50.5	50.9	-	-
52	11	-	-	-	-	-	-	49.6	50.1	-
59	15	-	-	-	-	-	-	-	48.8	49.2
64	18	-	-	-	-	-	-	-	48.2	48.2
68	20	-	-	-	-	-	-	-	-	47.8

PEFY-P140VMH-E-F

Outdoor air temp.		16°F W.B. -9°C W.B.	23°F W.B. -5°C W.B.	27°F W.B. -2.9°C W.B.	32°F W.B. 0°C W.B.	36°F W.B. 2°C W.B.	39°F W.B. 4°C W.B.	43°F W.B. 6°C W.B.	50°F W.B. 10°C W.B.	57°F W.B. 14°C W.B.
°F D.B.	°C D.B.	°C D.B.	°C D.B.	°C D.B.	°C D.B.	°C D.B.	°C D.B.	°C D.B.	°C D.B.	°C D.B.
18	-8	34.7	-	-	-	-	-	-	-	-
27	-3	-	45.8	-	-	-	-	-	-	-
32	0	-	-	45.6	-	-	-	-	-	-
37	3	-	-	-	45.4	45.4	-	-	-	-
45	7	-	-	-	-	45.2	45.2	45.2	-	-
52	11	-	-	-	-	-	-	45.0	45.0	-
59	15	-	-	-	-	-	-	-	44.7	45.1
64	18	-	-	-	-	-	-	-	44.6	44.6
68	20	-	-	-	-	-	-	-	-	44.4

PEFY-P200VMH-E-F

Outdoor air temp.		16°F W.B. -9°C W.B.	23°F W.B. -5°C W.B.	27°F W.B. -2.9°C W.B.	32°F W.B. 0°C W.B.	36°F W.B. 2°C W.B.	39°F W.B. 4°C W.B.	43°F W.B. 6°C W.B.	50°F W.B. 10°C W.B.	57°F W.B. 14°C W.B.
°F D.B.	°C D.B.	°C D.B.	°C D.B.	°C D.B.	°C D.B.	°C D.B.	°C D.B.	°C D.B.	°C D.B.	°C D.B.
18	-8	29.7	-	-	-	-	-	-	-	-
27	-3	-	40.0	-	-	-	-	-	-	-
32	0	-	-	40.3	-	-	-	-	-	-
37	3	-	-	-	40.6	40.7	-	-	-	-
45	7	-	-	-	-	40.8	40.9	41.0	-	-
52	11	-	-	-	-	-	-	41.2	41.4	-
59	15	-	-	-	-	-	-	-	41.5	41.7
64	18	-	-	-	-	-	-	-	41.7	41.8
68	20	-	-	-	-	-	-	-	-	41.9

PEFY-P250VMH-E-F

Outdoor air temp.		16°F W.B. -9°C W.B.	23°F W.B. -5°C W.B.	27°F W.B. -2.9°C W.B.	32°F W.B. 0°C W.B.	36°F W.B. 2°C W.B.	39°F W.B. 4°C W.B.	43°F W.B. 6°C W.B.	50°F W.B. 10°C W.B.	57°F W.B. 14°C W.B.
°F D.B.	°C D.B.	°C D.B.	°C D.B.	°C D.B.	°C D.B.	°C D.B.	°C D.B.	°C D.B.	°C D.B.	°C D.B.
18	-8	29.7	-	-	-	-	-	-	-	-
27	-3	-	40.0	-	-	-	-	-	-	-
32	0	-	-	40.3	-	-	-	-	-	-
37	3	-	-	-	40.6	40.7	-	-	-	-
45	7	-	-	-	-	40.8	40.9	41.0	-	-
52	11	-	-	-	-	-	-	41.2	41.4	-
59	15	-	-	-	-	-	-	-	41.5	41.7
64	18	-	-	-	-	-	-	-	41.6	41.8
68	20	-	-	-	-	-	-	-	-	41.9

SYSTEM DESIGN Y SERIES

1. Electrical work.....	190
1-1.General cautions	190
1-2.Power supply for Indoor unit and Outdoor unit	191
1-3.Power cable specifications	196
1-4.Power supply examples.....	197
2. M-NET control.....	200
2-1.Transmission cable length limitation.....	200
2-2.Transmission cable specifications	201
2-3.System configuration restrictions.....	206
2-4.Address setting	209
3. Piping Design.....	222
3-1.Piping Design	222
3-2.Refrigerant charging calculation	228
4. Outdoor Installation.....	229
4-1.Requirement on installation site	229
4-2.Spacing.....	230
4-3.Piping direction	232
4-4.Weather countermeasure	237
4-5.Caution on selecting outdoor units	238
5. Caution for refrigerant leakage	239
5-1.Refrigerant property.....	239
5-2.Confirm the Critical concentration and take countermeasure.....	239

1. Electrical work

1-1. General cautions

- ① Follow ordinance of your governmental organization for technical standard related to electrical equipment, wiring regulations, and guidance of each electric power company.
- ② Wiring for control (hereinafter referred to as transmission cable) shall be (50mm[1-5/8in.] or more) apart from power source wiring so that it is not influenced by electric noise from power source wiring. (Do not insert transmission cable and power source wire in the same conduit.)
- ③ Be sure to provide designated grounding work to outdoor unit.
- ④ Give some allowance to wiring for electrical part box of indoor and outdoor units, because the box is sometimes removed at the time of service work.
- ⑤ Never connect 380~415V(220~240V) power source to terminal block of transmission cable. If connected, electrical parts will be burnt out.
- ⑥ Use 2-core shield cable for transmission cable. If transmission cables of different systems are wired with the same multiple-core cable, the resultant poor transmitting and receiving will cause erroneous operations.

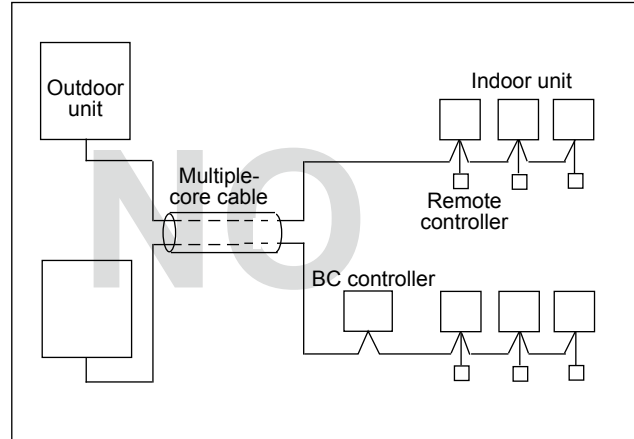
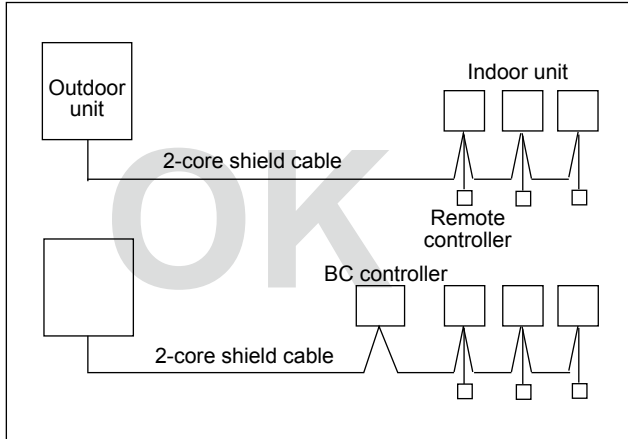

1. Electrical work

1-2. Power supply for Indoor unit and Outdoor unit

1-2-1. Electrical characteristics of Indoor unit

Symbols: MCA : Max.Circuit Amps (=1.25xFLA) FLA : Full Load Amps

IFM :Indoor Fan Motor Output : Fan motor rated output

PMFY-P-VBM-E	Power supply			IFM	
	Volts / Hz	Range +-10%	MCA(A)	Output(kW)	FLA(A)
PMFY-P20VBM-E	220-240V / 50Hz 220V / 60Hz	Max.: 264V Min.: 198V	0.25	0.028	0.20
PMFY-P25VBM-E			0.26	0.028	0.21
PMFY-P32VBM-E			0.26	0.028	0.21
PMFY-P40VBM-E			0.33	0.028	0.26

PLFY-P-VCM-E	Power supply			IFM	
	Volts / Hz	Range +-10%	MCA(A)	Output(kW)	FLA(A)
PLFY-P20VCM-E	220-240V / 50Hz	Max.: 264V Min.: 198V	0.29	0.011	0.23
PLFY-P25VCM-E			0.29	0.015	0.23
PLFY-P32VCM-E			0.35	0.020	0.28
PLFY-P40VCM-E			0.35	0.020	0.28

PLFY-P-VBM-E	Power supply			IFM	
	Volts / Hz	Range +-10%	MCA(A)	Output(kW)	FLA(A)
PLFY-P32VBM-E	220-240V / 50Hz 220V / 60Hz	Max.: 264V Min.: 198V	0.28	0.050	0.22
PLFY-P40VBM-E			0.36	0.050	0.29
PLFY-P50VBM-E			0.36	0.050	0.29
PLFY-P63VBM-E			0.45	0.050	0.36
PLFY-P80VBM-E			0.64	0.050	0.51
PLFY-P100VBM-E			1.25	0.120	1.00
PLFY-P125VBM-E			1.34	0.120	1.07

PLFY-P-VLMD-E	Power supply			IFM	
	Volts / Hz	Range +-10%	MCA(A) (50 / 60Hz)	Output(kW)	FLA(A) (50 / 60Hz)
PLFY-P20VLMD-E	220-240V / 50Hz 220-230V / 60Hz	Max.: 264V Min.: 198V	0.45 / 0.46	0.015	0.36 / 0.37
PLFY-P25VLMD-E			0.45 / 0.46	0.015	0.36 / 0.37
PLFY-P32VLMD-E			0.45 / 0.46	0.015	0.36 / 0.37
PLFY-P40VLMD-E			0.50 / 0.53	0.015	0.40 / 0.42
PLFY-P50VLMD-E			0.51 / 0.54	0.020	0.41 / 0.43
PLFY-P63VLMD-E			0.61 / 0.64	0.020	0.49 / 0.51
PLFY-P80VLMD-E			0.90 / 0.93	0.020	0.72 / 0.74
PLFY-P100VLMD-E			0.94 / 1.10	0.030	0.75 / 0.88
PLFY-P125VLMD-E			1.69 / 1.69	0.078x2	1.35 / 1.35

PEFY-P-VMR-E-L/R	Power supply			IFM	
	Volts / Hz	Range +-10%	MCA(A) (50 / 60Hz)	Output(kW)	FLA(A) (50 / 60Hz)
PEFY-P20VMR-E-L/R	220-240V / 50Hz 220-230V / 60Hz	Max.: 264V Min.: 198V	0.37 / 0.37	0.018	0.29 / 0.29
PEFY-P25VMR-E-L/R			0.37 / 0.37	0.018	0.29 / 0.29
PEFY-P32VMR-E-L/R			0.43 / 0.48	0.023	0.34 / 0.38

PEFY-P-VMS1-E	Power supply			IFM	
	Volts / Hz	Range +-10%	MCA(A) (50 / 60Hz)	Output(kW)	FLA(A) (50 / 60Hz)
PEFY-P15VMS1-E	220-240V / 50Hz 220-240V / 60Hz	Max.: 264V Min.: 198V	0.63 / 0.63	0.096	0.50 / 0.50
PEFY-P20VMS1-E			0.70 / 0.70	0.096	0.56 / 0.56
PEFY-P25VMS1-E			0.75 / 0.75	0.096	0.60 / 0.60
PEFY-P32VMS1-E			0.75 / 0.75	0.096	0.60 / 0.60
PEFY-P40VMS1-E			0.83 / 0.82	0.096	0.66 / 0.65
PEFY-P50VMS1-E			1.02 / 1.00	0.096	0.81 / 0.80
PEFY-P63VMS1-E			1.08 / 1.07	0.096	0.86 / 0.85

1. Electrical work

Symbols: MCA : Max.Circuit Amps (=1.25xFLA) FLA : Full Load Amps
 IFM :Indoor Fan Motor Output : Fan motor rated output

PEFY-P-VMS1L-E	Power supply			IFM	
	Volts / Hz	Range +-10%	MCA(A) (50 / 60Hz)	Output(kW)	FLA(A) (50 / 60Hz)
PEFY-P15VMS1L-E	220-240V / 50Hz 220-240V / 60Hz	Max.: 264V Min.: 198V	0.46 / 0.46	0.096	0.37 / 0.37
PEFY-P20VMS1L-E			0.54 / 0.54	0.096	0.43 / 0.43
PEFY-P25VMS1L-E			0.59 / 0.59	0.096	0.47 / 0.47
PEFY-P32VMS1L-E			0.59 / 0.59	0.096	0.47 / 0.47
PEFY-P40VMS1L-E			0.68 / 0.68	0.096	0.54 / 0.54
PEFY-P50VMS1L-E			0.84 / 0.84	0.096	0.67 / 0.67
PEFY-P63VMS1L-E			0.91 / 0.91	0.096	0.73 / 0.73

PEFY-P-VMH-E	Power supply			IFM	
	Volts / Hz	Range +-10%	MCA(A) (50 / 60Hz)	Output(kW)	FLA(A) (50 / 60Hz)
PEFY-P40VMH-E	220-240V / 50Hz 220-240V / 60Hz	Max.: 264V Min.: 198V	1.21 / 1.61	0.08	0.97 / 1.29
PEFY-P50VMH-E			1.21 / 1.61	0.08	0.97 / 1.29
PEFY-P63VMH-E			1.49 / 1.95	0.12	1.19 / 1.56
PEFY-P71VMH-E			1.58 / 2.18	0.14	1.26 / 1.74
PEFY-P80VMH-E			1.85 / 2.40	0.18	1.48 / 1.92
PEFY-P100VMH-E			3.03 / 3.93	0.26	2.42 / 3.14
PEFY-P125VMH-E			3.03 / 3.93	0.26	2.42 / 3.14
PEFY-P140VMH-E			3.10 / 3.98	0.26	2.48 / 3.18
PEFY-P200VMH-E	380-415V / 50Hz	Max.: 456V Min.: 342V	2.03 / 2.33	0.76	1.62 / 1.86
PEFY-P250VMH-E	380-415V / 60Hz		2.50 / 2.88	1.08	2.00 / 2.30

PEFY-P-VMA-E	Power supply			IFM	
	Volts / Hz	Range +-10%	MCA(A)	Output(kW)	FLA(A)
PEFY-P20VMA-E	220-240V / 50Hz 220-240V / 60Hz	Max.: 264V Min.: 198V	1.03	0.085	0.82
PEFY-P25VMA-E			1.03	0.085	0.82
PEFY-P32VMA-E			1.18	0.085	0.95
PEFY-P40VMA-E			1.43	0.085	1.14
PEFY-P50VMA-E			1.54	0.085	1.23
PEFY-P63VMA-E			2.22	0.121	1.78
PEFY-P71VMA-E			2.46	0.121	1.97
PEFY-P80VMA-E			2.47	0.121	1.98
PEFY-P100VMA-E			3.30	0.244	2.64
PEFY-P125VMA-E			3.39	0.244	2.71
PEFY-P140VMA-E			3.29	0.244	2.63

PEFY-P-VMAL-E	Power supply			IFM	
	Volts / Hz	Range +-10%	MCA(A)	Output(kW)	FLA(A)
PEFY-P20VMAL-E	220-240V / 50Hz 220-240V / 60Hz	Max.: 264V Min.: 198V	0.92	0.085	0.74
PEFY-P25VMAL-E			0.92	0.085	0.74
PEFY-P32VMAL-E			1.07	0.085	0.86
PEFY-P40VMAL-E			1.32	0.085	1.06
PEFY-P50VMAL-E			1.40	0.085	1.12
PEFY-P63VMAL-E			2.08	0.121	1.67
PEFY-P71VMAL-E			2.32	0.121	1.86
PEFY-P80VMAL-E			2.36	0.121	1.89
PEFY-P100VMAL-E			3.19	0.244	2.55
PEFY-P125VMAL-E			3.27	0.244	2.62
PEFY-P140VMAL-E			3.17	0.244	2.53

PEFY-P-VMH-E-F	Power supply			IFM	
	Volts / Hz	Range +-10%	MCA(A) (50 / 60Hz)	Output(kW)	FLA(A) (50 / 60Hz)
PEFY-P80VMH-E-F	220-240V / 50Hz	Max.: 264V	0.92 / 1.15	0.09	0.73 / 0.92
PEFY-P140VMH-E-F	208-230V / 60Hz	Min.: 187V	1.58 / 1.84	0.14	1.26 / 1.47
PEFY-P200VMH-E-F	380-415V / 50Hz	Max.: 456V	0.73 / 0.93	0.20	0.58 / 0.74
PEFY-P250VMH-E-F	380-415V / 60Hz	Min.: 342V	0.85 / 1.08	0.23	0.68 / 0.86

1. Electrical work

Symbols: MCA : Max.Circuit Amps (=1.25xFLA) FLA : Full Load Amps
IFM :Indoor Fan Motor Output : Fan motor rated output

PKFY-P-VBM-E	Power supply			IFM	
	Volts / Hz	Range +-10%	MCA(A)	Output(kW)	FLA(A)
PKFY-P15VBM-E	220-240V / 50Hz 220V / 60Hz	Max.: 264V Min.: 198V	0.25	0.017	0.20
PKFY-P20VBM-E			0.25	0.017	0.20
PKFY-P25VBM-E			0.25	0.017	0.20

PKFY-P-VHM-E	Power supply			IFM	
	Volts / Hz	Range +-10%	MCA(A)	Output(kW)	FLA(A)
PKFY-P32VHM-E	220-240V / 50Hz 220V / 60Hz	Max.: 264V Min.: 198V	0.38	0.030	0.30
PKFY-P40VHM-E			0.38	0.030	0.30
PKFY-P50VHM-E			0.38	0.030	0.30

PKFY-P-VKM-E	Power supply			IFM	
	Volts / Hz	Range +-10%	MCA(A)	Output(kW)	FLA(A)
PKFY-P63VKM-E	220-240V / 50Hz 220V / 60Hz	Max.: 264V Min.: 198V	0.36	0.056	0.29
PKFY-P100VKM-E			0.63	0.056	0.50

PCFY-P-VKM-E	Power supply			IFM	
	Volts / Hz	Range +-10%	MCA(A)	Output(kW)	FLA(A)
PCFY-P40VKM-E	220-240V / 50Hz 220V / 60Hz	Max.: 264V Min.: 198V	0.35	0.090	0.28
PCFY-P63VKM-E			0.41	0.095	0.33
PCFY-P100VKM-E			0.81	0.160	0.65
PCFY-P125VKM-E			0.95	0.160	0.76

PFFY-P-VKM-E	Power supply			IFM	
	Volts / Hz	Range +-10%	MCA(A)	Output(kW)	FLA(A)
PFFY-P20VKM-E	220-240V / 50Hz	Max.: 264V Min.: 198V	0.25	0.03x2	0.20
PFFY-P25VKM-E			0.25	0.03x2	0.20
PFFY-P32VKM-E			0.25	0.03x2	0.20
PFFY-P40VKM-E			0.30	0.03x2	0.24

PFFY-P-VLEM-E	Power supply			IFM	
	Volts / Hz	Range +-10%	MCA(A) (50 / 60Hz)	Output(kW)	FLA(A) (50 / 60Hz)
PFFY-P20VLEM-E	220-240V / 50Hz 208-230V / 60Hz	Max.: 264V Min.: 187V	0.24 / 0.31	0.015	0.19 / 0.25
PFFY-P25VLEM-E			0.24 / 0.31	0.015	0.19 / 0.25
PFFY-P32VLEM-E			0.36 / 0.38	0.018	0.29 / 0.30
PFFY-P40VLEM-E			0.40 / 0.41	0.030	0.32 / 0.33
PFFY-P50VLEM-E			0.50 / 0.51	0.035	0.40 / 0.41
PFFY-P63VLEM-E			0.58 / 0.59	0.050	0.46 / 0.47

1. Electrical work

Symbols: MCA : Max.Circuit Amps (=1.25xFLA) FLA : Full Load Amps

IFM :Indoor Fan Motor Output : Fan motor rated output

PFFY-P-VLRM-E	Power supply			IFM	
	Volts / Hz	Range +-10%	MCA(A) (50 / 60Hz)	Output(kW)	FLA(A) (50 / 60Hz)
PFFY-P20VLRM-E	220-240V / 50Hz 208-230V / 60Hz	Max.: 264V Min.: 187V	0.24 / 0.31	0.015	0.19 / 0.25
PFFY-P25VLRM-E			0.24 / 0.31	0.015	0.19 / 0.25
PFFY-P32VLRM-E			0.36 / 0.38	0.018	0.29 / 0.30
PFFY-P40VLRM-E			0.40 / 0.41	0.030	0.32 / 0.33
PFFY-P50VLRM-E			0.50 / 0.51	0.035	0.40 / 0.41
PFFY-P63VLRM-E			0.58 / 0.59	0.050	0.46 / 0.47

PFFY-P-VLRMM-E	Power supply			IFM	
	Volts / Hz	Range +-10%	MCA(A) (50 / 60Hz)	Output(kW)	FLA(A) (50 / 60Hz)
PFFY-P20VLRMM-E	220-240V / 50Hz	Max.: 264V Min.: 198V	0.59 / 0.58	0.096	0.47 / 0.46
PFFY-P25VLRMM-E			0.59 / 0.58	0.096	0.47 / 0.46
PFFY-P32VLRMM-E			0.69 / 0.69	0.096	0.55 / 0.55
PFFY-P40VLRMM-E			0.78 / 0.76	0.096	0.62 / 0.61
PFFY-P50VLRMM-E			0.80 / 0.79	0.096	0.64 / 0.63
PFFY-P63VLRMM-E			0.93 / 0.93	0.096	0.74 / 0.74

GUF-RDH3	Power supply			IFM	
	Volts / Hz	Range +-10%	MCA(A) (50 / 60Hz)	Output(kW)	FLA(A) (50 / 60Hz)
GUF-50RD(H)3	220-240V / 50Hz	Max.: 264V	1.85 / 1.85	0.081x2	1.48 / 1.48
GUF-100RD(H)3	220V / 60Hz	Min.: 198V	3.49 / 3.49	0.16x2	2.79 / 2.79

1. Electrical work

1-2-2. Electrical characteristics of Outdoor unit

Model	Unit Combination	Units			Power supply	Compressor		FAN	RLA (A) (50 / 60Hz)	
		Hz	Volts	Voltage range	MCA(A)	Output (kW)	SC (A)	Output (kW)	Cooling	Heating
PUHY-RP200YJM-B(-BS)	-	50/60	380 400 415	Max:456V Min:342V	13.5	4.8	8	0.92	9.5/9.1/8.7	9.6/9.1/8.7
PUHY-RP250YJM-B(-BS)	-				18.3	6.8		0.92	12.8/12.2/11.7	12.1/11.5/11.1
PUHY-RP300YJM-B(-BS)	-				21.5	8.2		0.92	15.1/14.4/13.8	15.9/15.1/14.5
PUHY-RP350YJM-B(-BS)	-				28.4	9.9		0.92	19.9/18.9/18.2	21.2/20.2/19.4
PUHY-RP400YSJM-B(-BS)	PUHY-RP200YJM-B(-BS)				28.6	4.8		0.92	20.0/19.0/18.3	19.2/18.2/17.5
	PUHY-RP200YJM-B(-BS)					4.8		0.92		
PUHY-RP450YSJM-B(-BS)	PUHY-RP200YJM-B(-BS)				33.1	4.8		0.92	23.2/22.0/21.2	21.6/20.5/19.8
	PUHY-RP250YJM-B(-BS)					6.8		0.92		
PUHY-RP500YSJM-B(-BS)	PUHY-RP250YJM-B(-BS)				37.7	6.8		0.92	26.4/25.1/24.2	24.3/23.1/22.3
	PUHY-RP250YJM-B(-BS)					6.8		0.92		
PUHY-RP550YSJM-B(-BS)	PUHY-RP250YJM-B(-BS)				42.1	6.8		0.92	29.5/28.0/27.0	28.0/26.6/25.6
	PUHY-RP300YJM-B(-BS)					8.2		0.92		
PUHY-RP600YSJM-B(-BS)	PUHY-RP300YJM-B(-BS)				44.7	8.2		0.92	31.3/29.8/28.7	32.4/30.8/29.7
	PUHY-RP300YJM-B(-BS)					8.2		0.92		
PUHY-RP650YSJM-B(-BS)	PUHY-RP300YJM-B(-BS)				50.9	8.2		0.92	35.6/33.8/32.6	36.6/34.8/33.5
	PUHY-RP350YJM-B(-BS)					9.9		0.92		
PUHY-RP700YSJM-B(-BS)	PUHY-RP200YJM-B(-BS)				53.6	4.8		0.92	37.5/35.6/34.3	33.9/32.2/31.1
	PUHY-RP250YJM-B(-BS)					6.8		0.92		
	PUHY-RP250YJM-B(-BS)					6.8		0.92		
PUHY-RP750YSJM-B(-BS)	PUHY-RP250YJM-B(-BS)				58.2	6.8		0.92	40.7/38.7/37.3	36.7/34.9/33.6
	PUHY-RP250YJM-B(-BS)	6.8	0.92							
	PUHY-RP250YJM-B(-BS)	6.8	0.92							
PUHY-RP800YSJM-B(-BS)	PUHY-RP250YJM-B(-BS)	61.4	6.8	0.92	43.0/40.8/39.4	40.0/38.0/36.7				
	PUHY-RP250YJM-B(-BS)		6.8	0.92						
	PUHY-RP300YJM-B(-BS)		8.2	0.92						
PUHY-RP850YSJM-B(-BS)	PUHY-RP250YJM-B(-BS)	65.3	6.8	0.92	45.7/43.4/41.9	44.6/42.4/40.9				
	PUHY-RP300YJM-B(-BS)		8.2	0.92						
	PUHY-RP300YJM-B(-BS)		8.2	0.92						
PUHY-RP900YSJM-B(-BS)	PUHY-RP300YJM-B(-BS)	68.2	8.2	0.92	47.7/45.3/43.7	47.9/45.5/43.8				
	PUHY-RP300YJM-B(-BS)		8.2	0.92						
	PUHY-RP300YJM-B(-BS)		8.2	0.92						

1. Electrical work

1-3. Power cable specifications

Thickness of wire for main power supply, capacities of the switch and system impedance

	Model	Minimum wire thickness (mm ²)			Breaker for current leakage	Local switch (A)		Breaker for wiring (NFB) (A)	Max. Permissible System impedance
		Main cable	Branch	Ground		Capacity	Fuse		
Outdoor unit	PUHY-RP200YJM-B	4	-	4	30A 100mA 0.1sec. or less	25	25	30	*1
	PUHY-RP250YJM-B	4	-	4	30A 100mA 0.1sec. or less	25	25	30	*1
	PUHY-RP300YJM-B	4	-	4	30A 100mA 0.1sec. or less	32	32	30	*1
	PUHY-RP350YJM-B	6	-	6	40A 100mA 0.1sec. or less	40	40	40	0.26
Total operating current of the indoor unit	F0 = 20 or less *2	1.5	1.5	1.5	20A current sensitivity *3	20	20	20	(apply to IEC61000-3-3)
	F0 = 30 or less *2	2.5	2.5	2.5	30A current sensitivity *3	30	30	30	(apply to IEC61000-3-3)
	F0 = 40 or less *2	4.0	4.0	4.0	40A current sensitivity *3	40	40	40	(apply to IEC61000-3-3)

*1 Meets technical requirements of IEC61000-3-3

*2: Please take the larger of F1 or F2 as the value for F0.

F1 = Total operating maximum current of the indoor units × 1.2

F2 = (V1 × Quantity of Type A) + (V1 × Quantity of Type B) + (V1 × Quantity of Others)

Indoor unit		V1
Type A	PLFY-VBM, PMFY-VBM, PEFY-VMS1(L), PCFY-VKM, PKFY-VHM, PKFY-VKM, PFFY-VKM, PFFY-VLRMM	1.6
Type B	PEFY-VMA(L)	3.2
Others	Other indoor unit	0

*3: Current sensitivity is calculated using the following formula.

G1 = (V2 × Quantity of Type 1) + (V2 × Quantity of Type 2) + (V2 × Quantity of Others) + (V3 × Wire length [km])

G1	Current sensitivity
30mA or less	30mA 0.1sec. or less
100mA or less	100mA 0.1sec. or less

Indoor unit		V2
Type 1	PLFY-VBM, PMFY-VBM, PEFY-VMS1(L), PCFY-VKM, PKFY-VHM, PKFY-VKM, PFFY-VKM, PFFY-VLRMM	2.4
Type 2	PEFY-VMA(L)	1.6
Others	Other indoor unit	0

Wire thickness (mm ²)	V3
1.5	48
2.5	56
4.0	66

- Use dedicated power supplies for the outdoor unit and indoor unit. Ensure OC and OS are wired individually.
- Bear in mind ambient conditions (ambient temperature, direct sunlight, rain water, etc.) when proceeding with the wiring and connections.
- The wire size is the minimum value for metal conduit wiring. If the voltage drops, use a wire that is one rank thicker in diameter. Make sure the power-supply voltage does not drop more than 10%.
- Specific wiring requirements should adhere to the wiring regulations of the region.
- Power supply cords of parts of appliances for outdoor use shall not be lighter than polychloroprene sheathed flexible cord (design 245 IEC57). For example, use wiring such as YZW.
- A switch with at least 3 mm contact separation in each pole shall be provided by the Air Conditioner installer.

⚠ WARNING

- Be sure to use specified wires for connections and ensure no external force is imparted to terminal connections. If connections are not fixed firmly, heating or fire may result.
- Be sure to use the appropriate type of overcurrent protection switch. Note that generated overcurrent may include some amount of direct current.

⚠ CAUTION

- Some installation sites may require attachment of an earth leakage breaker for the inverter. If no earth leakage breaker is installed, there is a danger of electric shock.
- Do not use anything other than a breaker and fuse with the correct capacity. Using a fuse or wire of too large capacity may cause malfunction or fire.
- Check the existing wires for damage to insulation by measuring the resistance between the lead and the ground with a 500V ohmmeter. If the insulation resistance is less than 100 MΩ, replace the wires.

Note

- This device is intended for the connection to a power supply system with a maximum permissible system impedance shown in the above table at the interface point (power service box) of the user's supply.
- The user must ensure that this device is connected only to a power supply system which fulfils the requirement above. If necessary, the user can ask the public power supply company for the system impedance at the interface point.
- This equipment complies with IEC 61000-3-12 provided that the short-circuit power Ssc is greater than or equal to Ssc(*2) at the interface point between the user's supply and the public system. It is the responsibility of the installer or user of the equipment to ensure, by consultation with the distribution network operator if necessary, that the equipment is connected only to a supply with a short-circuit power Ssc greater than or equal to Ssc(*2).

Ssc(*2)

Model	Ssc(MVA)
PUHY-RP200YJM	1.25
PUHY-RP250YJM	1.54
PUHY-RP300YJM	1.75
PUHY-RP350YJM	2.31

1. Electrical work

1-4. Power supply examples

The local standards and/or regulations is applicable at a higher priority.
 1-4-1. PUHY-RP200-350YJM-B

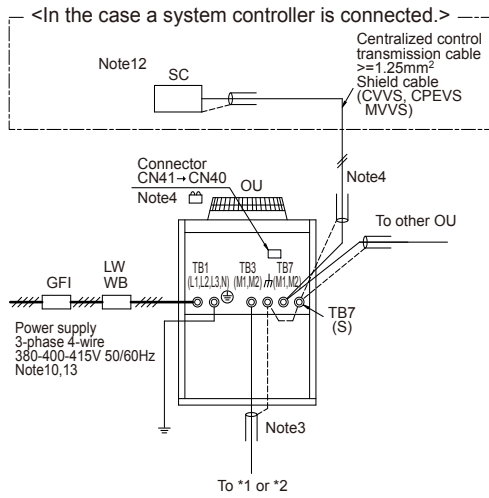

- Note:
- The transmission cable is not-polarity double-wire.
 - Symbol \oplus means a screw terminal for wiring.
 - The shield wire of transmission cable should be connected to the grounding terminal at Outdoor unit. All shield wire of M-Net transmission cable among Indoor units should be connected to the S terminal at Indoor unit or all shield wire should be connected together. The broken line at the scheme means shield wire.
 - When the Outdoor unit connected with system controller, power-supply to TB7 of the outdoor unit(s) is needed. The connector change from CN41 to CN40 at one of the outdoor units will enable the outdoor unit to supply power to TB7, or an extra power supplying unit PAC-SC51KUA should be used. The transmission cable (above 1.25mm^2 , shielded, CVVS/CPEVS/MVVS) among Outdoor units and system controllers is called centralized control transmission cable. The shield wire of the centralized control transmission cable must be grounded at the Outdoor unit whose CN41 is changed to CN40.
 - MA R/C transmission cable ($0.3\sim 1.25\text{mm}^2$) must be less than 200m in length, while ME R/C transmission cable ($0.3\sim 1.25\text{mm}^2$) must be less than 10m in length. But transmission cable to the ME R/C can be extend using a M-NET cable ($\geq 1.25\text{mm}^2$) when the length is counted in the M-Net length. Both Compact MA and ME R/C transmission cables size $0.75\sim 1.25\text{mm}^2$ in thickness.
 - MA remote controller and ME remote controller should not be grouped together.
 - If using 1 or 2 (main/sub) MA remote controller to control more than 1 Indoor unit, use MA transmission cable to connect all the TB15 terminals of the Indoor units. It is called "Grouping". If using 1 or 2 (main/sub) ME remote controller control more than 1 indoor unit, set address to Indoor unit and ME remote controller. For the method, refer to 2-4. "Address Setting".
 - Indoor board consumes power from TB3. The power balance should be considered according to System Design 2-3 "System configuration restrictions".
 - If Transmission booster is needed, be sure to connect the shield wires to the both sides to the booster.
 - The critical current for choosing power source equipment is approximate 1.4 times of total rated current of the Outdoor unit(s) or Indoor unit(s).
 - Numbers shown with () indicates a diameter of the compact remote controller.
 - When System controller (SC) is connected to the system, turn the SW2-1 on.
 - The phases of electricity power must be confirmed to be right used. Phase-reverse, or phase-missing could break the controllers.

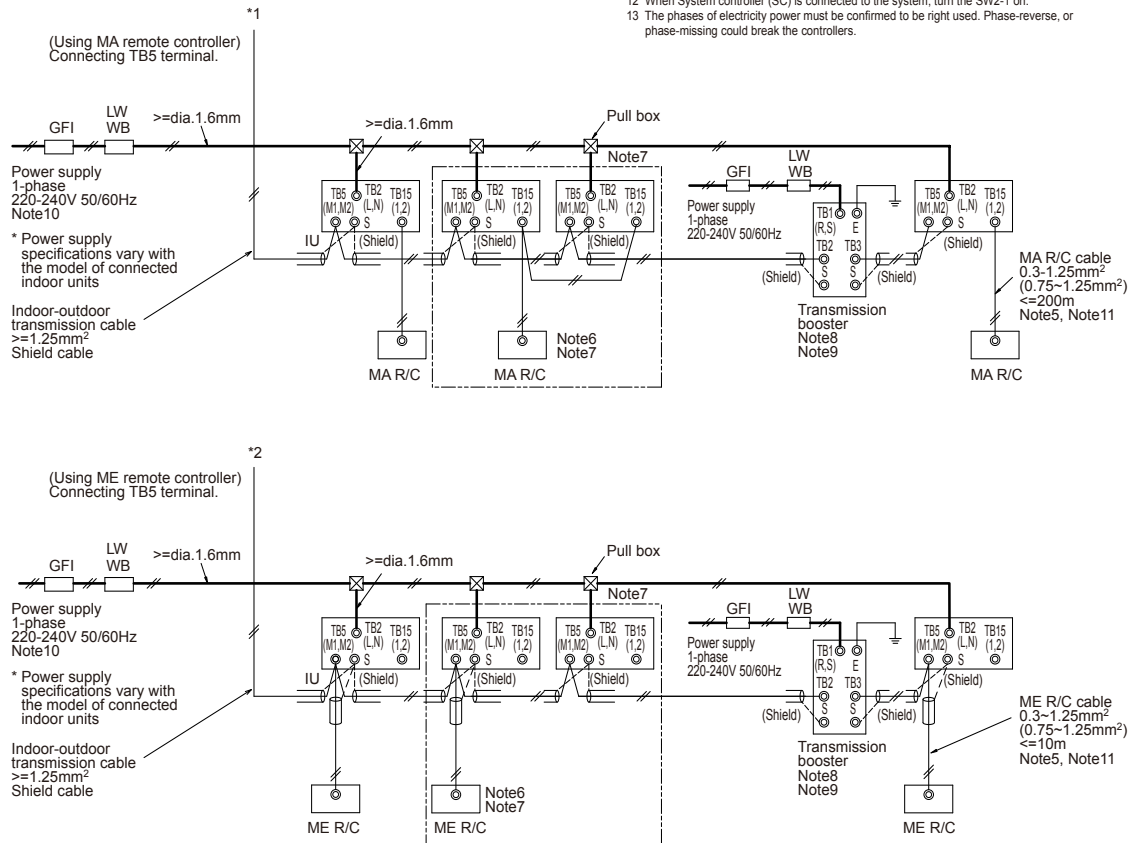

Symbol	Model	Ground-fault interrupter *1, *2	Local switch		Wiring breaker (NFB) <A>	Minimum Wire thickness		
			BC <A>	OCP*3 <A>		Power wire <mm ² >	Earth wire <mm ² >	
GFI	Ground-fault interrupter	PUHY-RP200YJM	30A 100mA 0.1sec. or less	25	25	30	4	4
LW	Local switch	PUHY-RP250YJM	30A 100mA 0.1sec. or less	25	25	30	4	4
BC	Breaker capacity	PUHY-RP300YJM	30A 100mA 0.1sec. or less	32	32	30	4	4
OCP	Over-current protector	PUHY-RP350YJM	40A 100mA 0.1sec. or less	40	40	40	6	6
WB	Wiring breaker							
NFB	Non-fuse breaker							
OU	Outdoor unit							
IU	Indoor unit							
SC	System controller							
MA R/C	MA remote controller							
ME R/C	ME remote controller							

*1 The Ground-fault interrupter should support Inverter circuit. (e.g. Mitsubishi Electric's NV-C series or equivalent).

*2 Ground-fault interrupter should combine using of local switch or wiring breaker.

*3 It shows data for B-type fuse of the breaker for current leakage.

1. Electrical work

The local standards and/or regulations is applicable at a higher priority.
1-4-2. PUHY-RP400-650YSJM-B

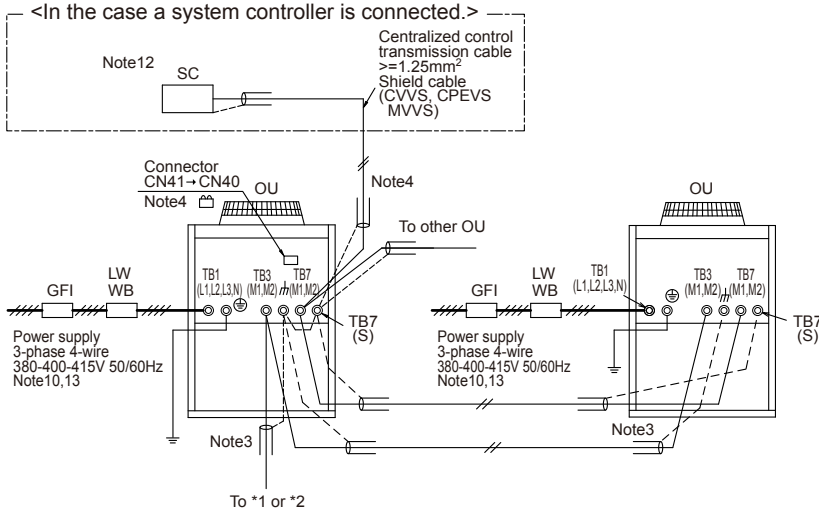

- Note:
- The transmission cable is not-polarity double-wire.
 - Symbol ⊙ means a screw terminal for wiring.
 - The shield wire of transmission cable should be connected to the grounding terminal at Outdoor unit. All shield wire of M-Net transmission cable among Indoor units should be connected to the S terminal at Indoor unit or all shield wire should be connected together. The broken line at the scheme means shield wire.
 - When the Outdoor unit connected with system controller, power-supply to TB7 of the outdoor unit(s) is needed. The connector change from CN41 to CN40 at one of the outdoor units will enable the outdoor unit to supply power to TB7, or an extra power supplying unit PAC-SC51KUA should be used. The transmission cable (above 1.25mm², shielded, CVVS/CPEVS/MVVS) among Outdoor units and system controllers is called centralized control transmission cable. The shield wire of the centralized control transmission cable must be grounded at the Outdoor unit whose CN41 is changed to CN40.
 - MA R/C transmission cable (0.3-1.25mm²) must be less than 200m in length, while ME R/C transmission cable (0.3-1.25mm²) must be less than 10m in length. But transmission cable to the ME R/C can be extend using a M-NET cable ($\geq 1.25\text{mm}^2$) when the length is counted in the M-Net length. Both Compact MA and ME R/C transmission cables size 0.75-1.25mm² in thickness.
 - MA remote controller and ME remote controller should not be grouped together.
 - If using 1 or 2 (main/sub) MA remote controller to control more than 1 Indoor unit, use MA transmission cable to connect all the TB15 terminals of the Indoor units. It is called "Grouping". If using 1 or 2 (main/sub) ME remote controller control more than 1 indoor unit, set address to Indoor unit and ME remote controller. For the method, refer to 2-4. "Address Setting".
 - Indoor board consumes power from TB3. The power balance should be considered according to System Design 2-3 "System configuration restrictions".
 - If Transmission booster is needed, be sure to connect the shield wires to the both sides to the booster.
 - The critical current for choosing power source equipment is approximate 1.4 times of total rated current of the Outdoor unit(s) or Indoor unit(s).
 - Numbers shown with () indicates a diameter of the compact remote controller.
 - When System controller (SC) is connected to the system, turn the SW2-1 on.
 - The phases of electricity power must be confirmed to be right used. Phase-reverse, or phase-missing could break the controllers.

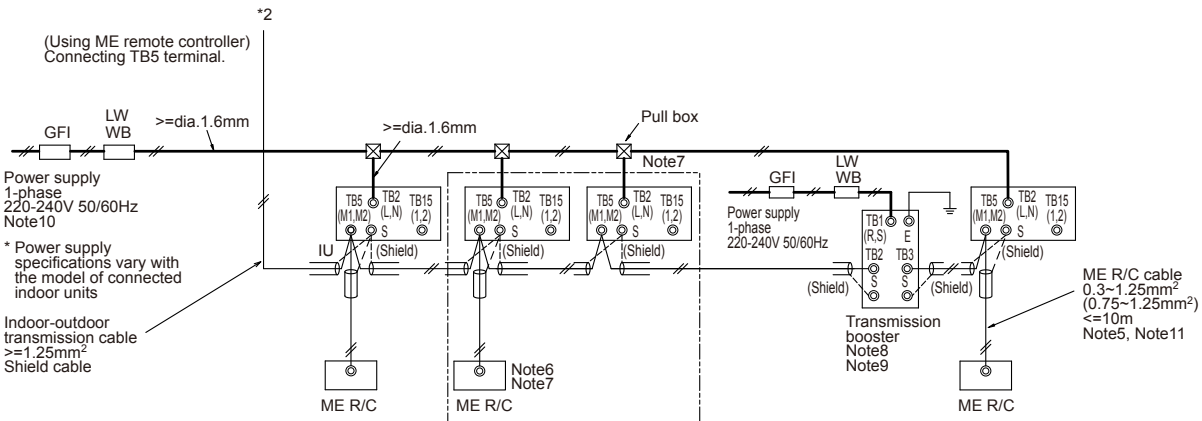
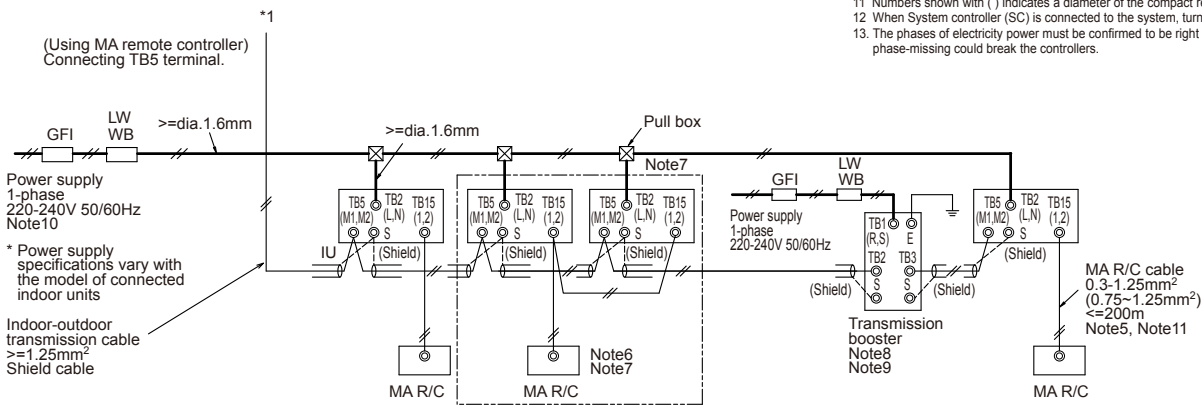

Symbol	Model	Ground-fault interrupter *1, *2	Local switch			Wiring breaker (NFB) <A>	Minimum Wire thickness	
			BC <A>	OCP*3 <A>			Power wire <mm ² >	Earth wire <mm ² >
GFI	Ground-fault interrupter	PUHY-RP200YJM	30A 100mA 0.1sec. or less	25	25	30	4	4
LW	Local switch	PUHY-RP250YJM	30A 100mA 0.1sec. or less	25	25	30	4	4
BC	Breaker capacity	PUHY-RP300YJM	30A 100mA 0.1sec. or less	32	32	30	4	4
OCP	Over-current protector	PUHY-RP350YJM	40A 100mA 0.1sec. or less	40	40	40	6	6
WB	Wiring breaker							
NFB	Non-fuse breaker							
OU	Outdoor unit							
IU	Indoor unit							
SC	System controller							
MA R/C	MA remote controller							
ME R/C	ME remote controller							

*1 The Ground-fault interrupter should support Inverter circuit. (e.g. Mitsubishi Electric's NV-C series or equivalent).

*2 Ground-fault interrupter should combine using of local switch or wiring breaker.

*3 It shows data for B-type fuse of the breaker for current leakage.

1. Electrical work

The local standards and/or regulations is applicable at a higher priority.

1-4-3. PUHY-RP700-900YSJM-B

<In the case a system controller is connected.>

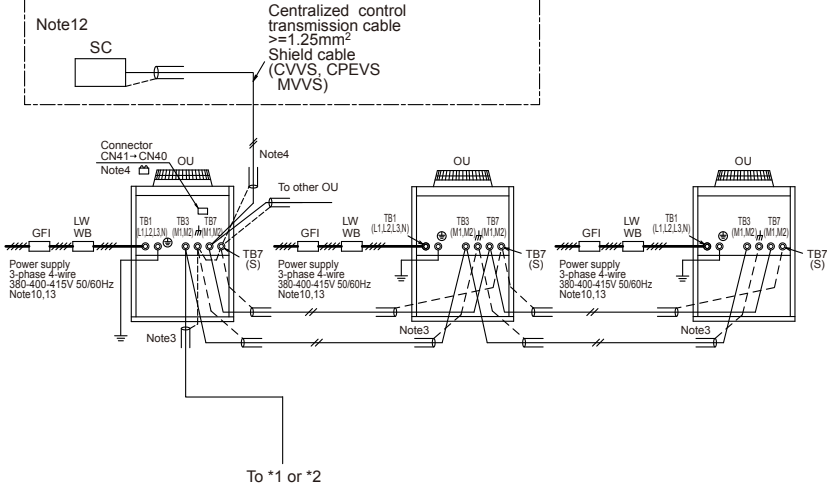

- Note:
- The transmission cable is not-polarity double-wire.
 - Symbol Ⓞ means a screw terminal for wiring.
 - The shield wire of transmission cable should be connected to the grounding terminal at Outdoor unit. All shield wire of M-Net transmission cable among Indoor units should be connected to the S terminal at Indoor unit or all shield wire should be connected together. The broken line at the scheme means shield wire.
 - When the Outdoor unit connected with system controller, power-supply to TB7 of the outdoor unit(s) is needed. The connector change from CN41 to CN40 at one of the outdoor units will enable the outdoor unit to supply power to TB7, or an extra power supplying unit PAC-SC51KUA should be used. The transmission cable (above 1.25mm², shielded, CVVS/CPEVS/MVVS) among Outdoor units and system controllers is called centralized control transmission cable. The shield wire of the centralized control transmission cable must be grounded at the Outdoor unit whose CN41 is changed to CN40.
 - MA R/C transmission cable (0.3-1.25mm²) must be less than 200m in length, while ME R/C transmission cable (0.3-1.25mm²) must be less than 10m in length. But transmission cable to the ME R/C can be extend using a M-Net cable (≥1.25mm²) when the length is counted in the M-Net length. Both Compact MA and ME R/C transmission cables size 0.75-1.25mm² in thickness.
 - MA remote controller and ME remote controller should not be grouped together.
 - If using 1 or 2 (main/sub) MA remote controller to control more than 1 Indoor unit, use MA transmission cable to connect all the TB15 terminals of the Indoor units. It is called "Grouping".
If using 1 or 2 (main/sub) ME remote controller control more than 1 indoor unit, set address to Indoor unit and ME remote controller. For the method, refer to 2-4. "Address Setting".
 - Indoor board consumes power from TB3. The power balance should be considered according to System Design 2-3 "System configuration restrictions".
 - If Transmission booster is needed, be sure to connect the shield wires to the both sides to the booster.
 - The critical current for choosing power source equipment is approximate 1.4 times of total rated current of the Outdoor unit(s) or Indoor unit(s).
 - Numbers shown with () indicates a diameter of the compact remote controller.
 - When System controller (SC) is connected to the system, turn the SW2-1 on.
 - The phases of electricity power must be confirmed to be right used. Phase-reverse, or phase-missing could break the controllers.

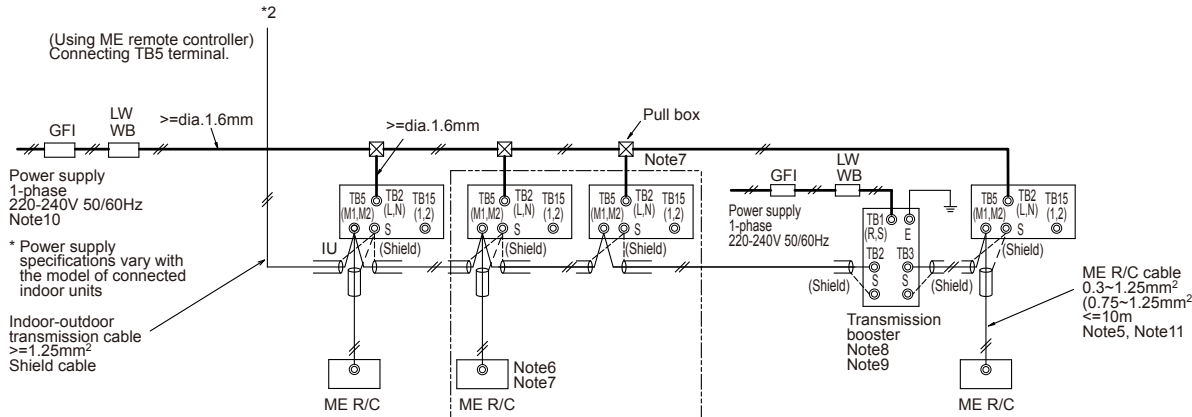
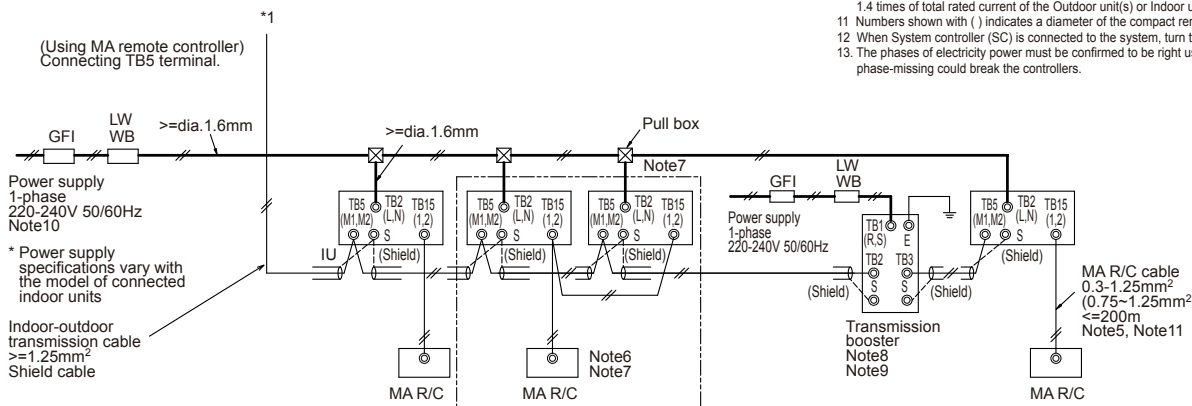

Symbol	Model	Ground-fault interrupter *1, *2	Local switch		Wiring breaker	Minimum Wire thickness		
			BC <A>	OCP*3 <A>	(NFB) <A>	Power wire <mm ² >	Earth wire <mm ² >	
GFI	Ground-fault interrupter	PUHY-RP200YJM	30A 100mA 0.1sec. or less	25	25	30	4	4
LW	Local switch	PUHY-RP250YJM	30A 100mA 0.1sec. or less	25	25	30	4	4
BC	Breaker capacity	PUHY-RP300YJM	30A 100mA 0.1sec. or less	32	32	30	4	4
OCP	Over-current protector	PUHY-RP350YJM	40A 100mA 0.1sec. or less	40	40	40	6	6

*1 The Ground-fault interrupter should support Inverter circuit. (e.g. Mitsubishi Electric's NV-C series or equivalent).
 *2 Ground-fault interrupter should combine using of local switch or wiring breaker.
 *3 It shows data for B-type fuse of the breaker for current leakage.

2. M-NET control

2-1. Transmission cable length limitation

2-1-1. Using MA Remote controller

Long transmission cable causes voltage down, therefore, the length limitation should be obeyed to secure proper transmission.

Max. length via Outdoor (M-NET cable)	$L_1+L_2+L_3+L_4, L_1+L_2+L_6+L_7, L_3+L_4+L_6+L_7$	$\leq 500\text{m}[1640\text{ft.}]$	1.25mm^2 [AWG16] or thicker
Max. length to Outdoor (M-NET cable)	$L_1+L_8, L_3+L_4, L_6, L_2+L_6+L_8, L_7$	$\leq 200\text{m}[656\text{ft.}]$	1.25mm^2 [AWG16] or thicker
Max. length from MA to Indoor	$a_1+a_2, a_1+a_2+a_3+a_4$	$\leq 200\text{m}[656\text{ft.}]$	$0.3\text{-}1.25\text{mm}^2$ [AWG22-16]
24VDC to AG-150A	n	$\leq 50\text{m}[164\text{ft.}]$	$0.75\text{-}2.0\text{mm}^2$ [AWG18-14]

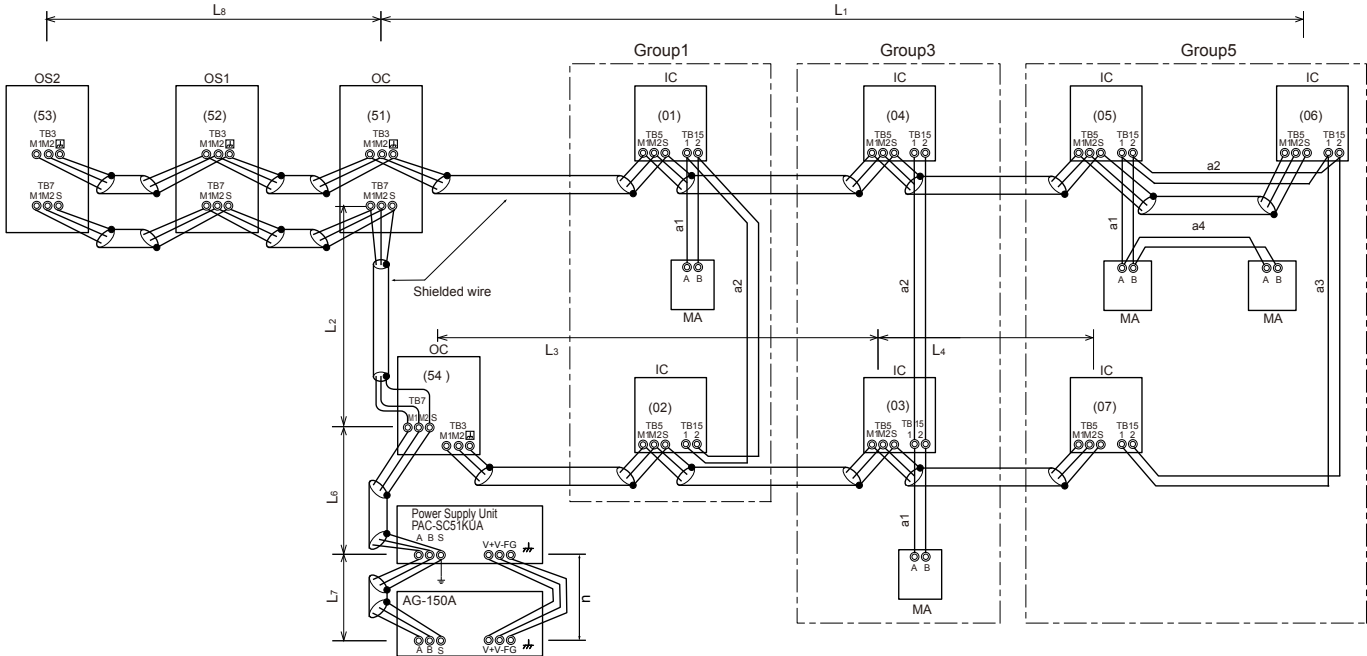

OC, OS1, OS2 : Outdoor unit controller; IC: Indoor unit controller; MA: MA remote controller

2-1-2. Using ME Remote controller

Long transmission cable causes voltage down, therefore, the length limitation should be obeyed to secure proper transmission.

Max. length via Outdoor (M-NET cable)	$L_1+L_2+L_3+L_4, L_1+L_2+L_6+L_7, L_1+L_2+L_3+L_5, L_3+L_4+L_6+L_7$	$\leq 500\text{m}[1640\text{ft.}]$	1.25mm^2 [AWG16] or thicker
Max. length to Outdoor (M-NET cable)	$L_1+L_8, L_3+L_4, L_6, L_2+L_6+L_8, L_7, L_3+L_5$	$\leq 200\text{m}[656\text{ft.}]$	1.25mm^2 [AWG16] or thicker
Max. length from ME to Indoor	e_1, e_2+e_3, e_4	$\leq 10\text{m}[32\text{ft.}]^*1$	$0.3\text{-}1.25\text{mm}^2$ [AWG22-16] *1
24VDC to AG-150A	n	$\leq 50\text{m}[164\text{ft.}]$	$0.75\text{-}2.0\text{mm}^2$ [AWG18-14]

*1. If the length from ME to Indoor exceed 10m, use 1.25mm^2 [AWG16] shielded cable, but the total length should be counted into Max. length via Outdoor.

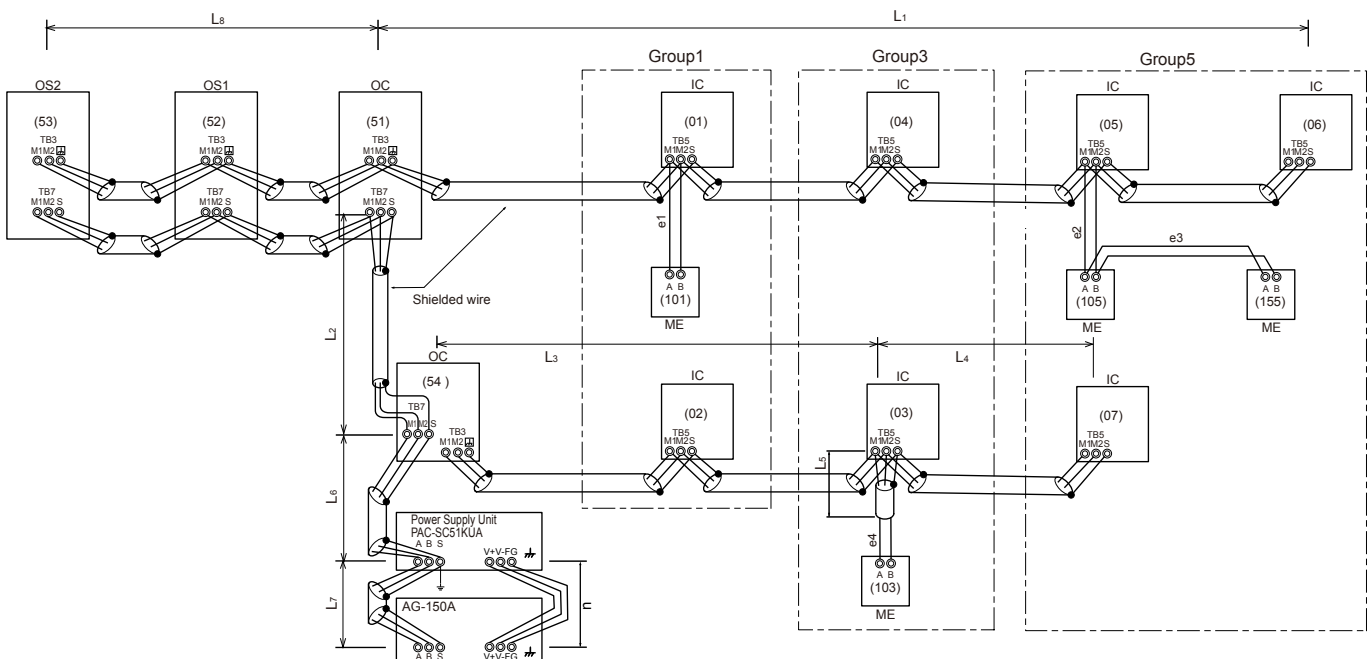

OC, OS1, OS2: Outdoor unit controller; IC: Indoor unit controller; ME: ME remote controller

2. M-NET control

2-2. Transmission cable specifications

	Transmission cables (Li)	ME Remote controller cables	MA Remote controller cables
Type of cable	Shielding wire (2-core) CVVS, CPEVS or MVVS	Sheathed 2-core cable (unshielded) CVV	
Cable size	More than 1.25mm ² [AWG16]	0.3~1.25mm ² [AWG22~16] (0.75~1.25mm ² [AWG18~16])*1	0.3~1.25mm ² [AWG22~16] (0.75~1.25mm ² [AWG18~16])*1
Remarks	—	When 10m [32ft] is exceeded, use cables with the same specification as transmission cables.	Max length : 200m [656ft]

*1 Connected with simple remote controller.

CVVS, MVVS : PVC insulated PVC jacketed shielded control cable
CPEVS : PE insulated PVC jacketed shielded communication cable
CVV : PV insulated PVC sheathed control cable

⚠ CAUTION

Check the existing wires for damage to insulation by measuring the resistance between the lead and the ground with a 500V ohmmeter. If the insulation resistance is less than 100 MΩ, replace the wires.

Disconnect all controllers before measuring insulation resistance to avoid controller damage.

Note: Disconnect the system controller before starting a refrigerant oil recovery operation, if one is connected.

Reconnect the system controller after the completion of the refrigerant oil recovery operation.

2. M-NET control

2-2-1. Reusability check of the existing transmission lines for Replace Multi units

Use the flowcharts on the following pages to determine the reusability of the existing transmission lines. Obtain the system configuration drawing, fill out the checklist, and make a decision based on them.

Existing transmission lines reusability checklist

Check items	Findings	Notes
1. Remote controller cable (MA remote controller)		
(1) Length	m	
(2) Cable size	mm ²	
(3) Number of cores	Cores	
(4) Cable type (shielded/unshielded)	Shielded/Unshielded	
2. Remote controller cable (ME remote controller)		
(1) Length *1	m	
(2) Cable size	mm ²	
(3) Number of cores	Cores	
(4) Cable type (shielded/unshielded)	Shielded/Unshielded	
3. Remote controller cable (system controller)		
(1) Length *1	m	
(2) Cable size	mm ²	
(3) Number of cores	Cores	
(4) Cable type (shielded/unshielded)	Shielded/Unshielded	
(5) System controller connection (Indoor unit system/centralized control system)	Indoor/Centralized	
4. Indoor-outdoor transmission line		
(1) Refrigerant system (Single/Multiple)	Single/Multiple	
(2) Length of transmission line to the farthest unit *1	m	
(3) Cable size	mm ²	
(4) Number of cores	Cores	
(5) Cable type (shielded/unshielded)	Shielded/Unshielded	
(6) Number of connected indoor units	units	
5. Centralized control transmission line		
(1) Length of transmission line to the farthest unit *1	m	
(2) Cable size	mm ²	
(3) Number of cores	Cores	
(4) Cable type (shielded/unshielded)	Shielded/Unshielded	
6. Availability of system configuration drawing (Obtain one as much as possible.)	Available/Not available	
7. Noise-related problems with the old units (Write down the nature of the problem in the "Notes" column, if any.)	Available/Not available	
8. Are there any high-frequency medical equipment in the adjacent area that could cause noise-interference? (Write down the specific nature of the concerns in the "Notes" column, if any.)	Available/Not available	

*1: If the remote controller (ME/System controller) length exceeds 10 m, include the exceeded length in the calculation of the transmission line length (indoor-outdoor transmission line/centralized control system).

2. M-NET control

Reusability of MA remote controller wiring

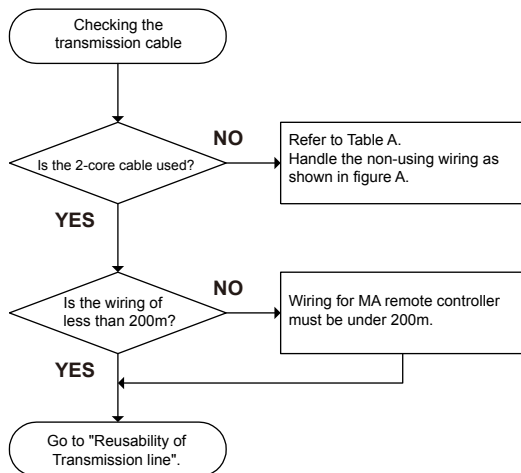

Reusability of M-NET remote controller wiring

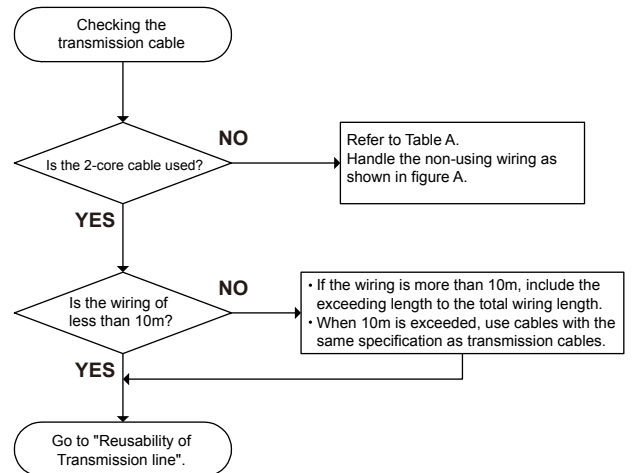

Reusability of System controller wiring

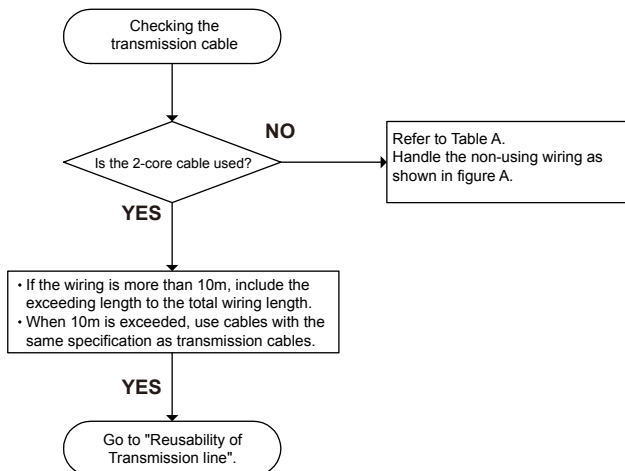
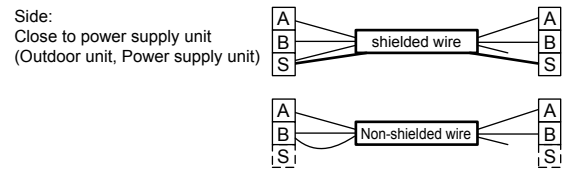

Figure A. Non-using wiring



Non using wiring on the power supply side (Outdoor unit, Power supply unit) should be connected to the shield terminal. The non-using wiring on the opposite side should be open and insulated.

Table A

	Transmission cables (Li)	ME Remote controller cables	MA Remote controller cables
Type of cable	Shielding wire (2-core) CVVS, CPEVS or MVVS	Sheathed 2-core cable (unshielded) CVV	
Cable size	More than 1.25mm ² [AWG16]	0.3 ~ 1.25mm ² [AWG22~16] (0.75 ~ 1.25mm ² [AWG18~16])*1	0.3 ~ 1.25mm ² [AWG22~16] (0.75 ~ 1.25mm ² [AWG18~16])*1
Remarks	—	When 10m [32ft] is exceeded, use cables with the same specification as transmission cables.	Max length : 200m [656ft]

*1 Connected with simple remote controller.

CVVS, MVVS : PVC insulated PVC jacketed shielded control cable
CPEVS : PE insulated PVC jacketed shielded communication cable
CVV : PV insulated PVC sheathed control cable

2. M-NET control

Determining the reusability of the transmission line

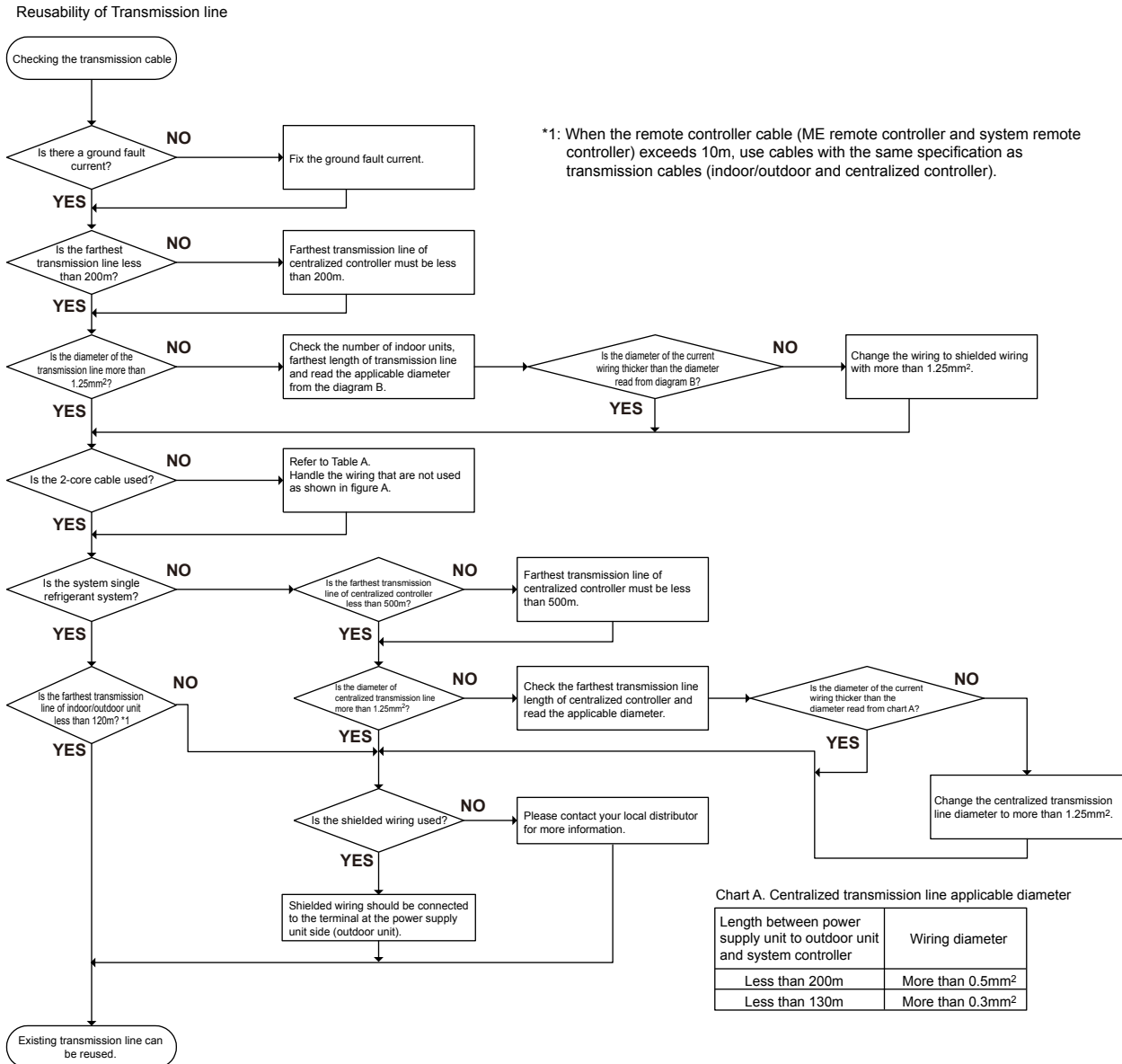
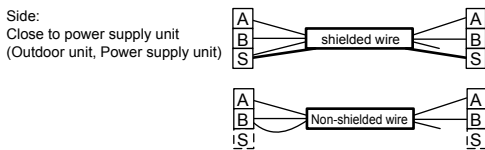

Figure A. Non-using wiring



Non using wiring on the power supply side (Outdoor unit, Power supply unit) should be connected to the shield terminal. The non-using wiring on the opposite side should be open and insulated.

Table A

	Transmission cables (Li)	ME Remote controller cables	MA Remote controller cables
Type of cable	Shielding wire (2-core) CVVS, CPEVS or MVVS	Sheathed 2-core cable (unshielded) CVV	
Cable size	More than 1.25mm ² [AWG16]	0.3 ~ 1.25mm ² [AWG22~16] (0.75 ~ 1.25mm ² [AWG18~16])*1	0.3 ~ 1.25mm ² [AWG22~16] (0.75 ~ 1.25mm ² [AWG18~16])*1
Remarks	—	When 10m [32ft] is exceeded, use cables with the same specification as transmission cables.	Max length : 200m [656ft]

*1 Connected with simple remote controller.

CVVS, MVVS : PVC insulated PVC jacketed shielded control cable
CPEVS : PE insulated PVC jacketed shielded communication cable
CVV : PV insulated PVC sheathed control cable

2. M-NET control

Diagram B Checking the cable size

MA remote controller

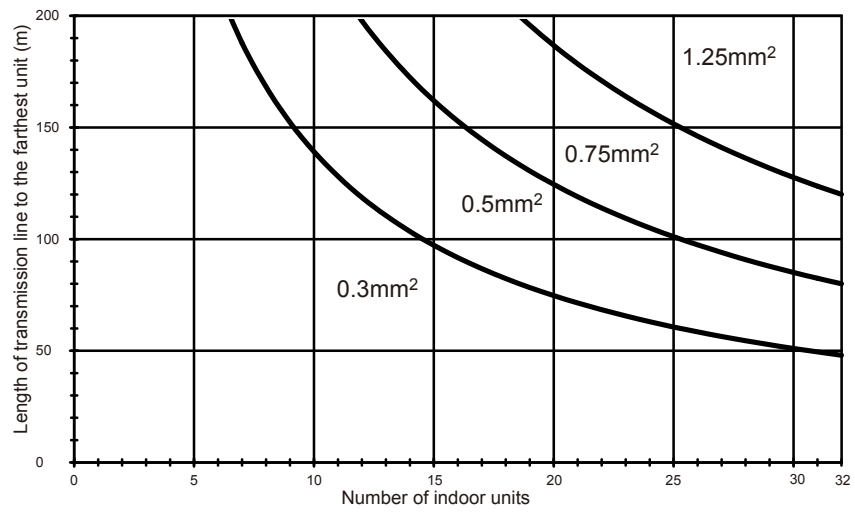

ME remote controller

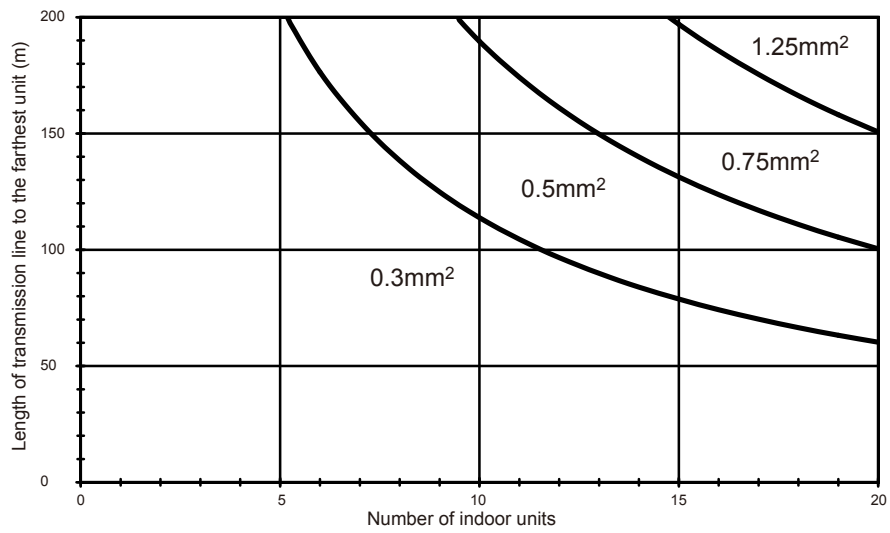

2. M-NET control

2-3. System configuration restrictions

2-3-1. Common restrictions for the CITYMULTI system

For each Outdoor unit, the maximum connectable quantity of Indoor unit is specified at its Specifications table.

- A) 1 Group of Indoor units can have 1-16 Indoor units;
*OA processing unit GUF-RD(H) is considered as Indoor unit.
- B) Maximum 2 remote controllers for 1 Group; (MA/ME remote controllers cannot be present together in 1group.)
- C) 1 LOSSNAY unit can interlock maximum 16 Indoor units; 1 Indoor unit can interlock only 1 LOSSNAY unit.
- D) Maximum 3 System controllers are connectable when connecting to TB3 of the Outdoor unit.
- E) Maximum 3 System controllers are connectable when connecting to TB7 of the Outdoor unit, if the transmission power is supplied by the Outdoor unit.
- F) 4 System controllers or more are connectable when connecting to TB7 of the Outdoor unit, if the transmission power is supplied by the power supply unit PAC-SC51KUA. Details refer to 2-3-3-C.
*System controller connected as described in D) and E) would have a risk that the failure of connected Outdoor unit would stop power supply to the System controller.

2-3-2. Ensuring proper communication power for M-NET

In order to ensure proper communication among Outdoor unit, Indoor unit, LOSSNAY, and OA processing unit GUF-RD(H), and Controllers, the transmission power situation for the M-NET should be observed. In some cases, Transmission booster should be used. Taking the power consumption of Indoor unit sized P20-P140 as 1, the equivalent power consumption or supply of others are listed at Table 2-3-1 and Table 2-3-2.

Table 2-3-1 The equivalent power consumption

Indoor, OA unit	Indoor unit	BC controller	MA RC. LOSSNAY	ME Remote Contr.	Timers, System Contr.	ON/OFF Contr.	MN Converter		
Sized P15-P140 GUF-50, 100	Sized P200,P250	CMB	PAR-30MAA PAR-21MAA PAC-YT51CRA(B) PAR-FA32MA LGH-RX-E PZ-60DR-E	PAR-F27MEA PAC-SE51CRA PZ-52SF-E	PAC-SC30GRA PAC-SF44SRA PAC-YT34STA AG-150A	AT-50A	PAC-YT40ANRA	CMS -MNF-B	CMS -MNG-E
1	7	2	0	1/4	1/2	4	1	1/2	2

*RC : Remote Controller

Table 2-3-2 The equivalent power supply

Transmission Booster	Power supply unit	Expansion controller	BM ADAPTER	System Controller	Outdoor unit	Outdoor unit
PAC-SF46EPA	PAC-SC51KUA	PAC-YG50ECA	BAC-HD150	GB-50ADA	Connector TB3 and TB7 total *	Connector TB7 only
25	5	6	6	6	32	6

*If PAC-SC51KUA is used to supply power at TB7 side, no power supply need from Outdoor unit at TB7, Connector TB3 itself will therefore have 32. Not applicable to the PUMY model.

With the equivalent power consumption values in Table 2-3-1 and Table 2-3-2, PAC-SF46EPA can be designed into the air-conditioner system to ensure proper system communication according to 2-3-2-A, B, C.

2-3-2-A) Firstly, count from TB3 at TB3 side the total quantity of Indoor units, OA process units and ME remote controller, Timers and System controllers. If the total quantity reaches 40, a PAC-SF46EPA should be set. In this case, Indoor unit sized P200, 250 is counted as 7 Indoor units, but MA remote controller(s), LOSSNAY, PZ-60DR-E is NOT counted.

2-3-2-B) Secondly, count from TB7 side to TB3 side the total transmission power consumption. If the total power consumption reaches 32, a PAC-SF46EPA should be set. Yet, if a PAC-SC51KUA is used to supply power at TB7 side, count from TB3 side only.

2-3-2-C) Thirdly, count from TB7 at TB7 side the total transmission power consumption, If the total power consumption reaches 6, a PAC-SF46EPA should be set.

■ System example

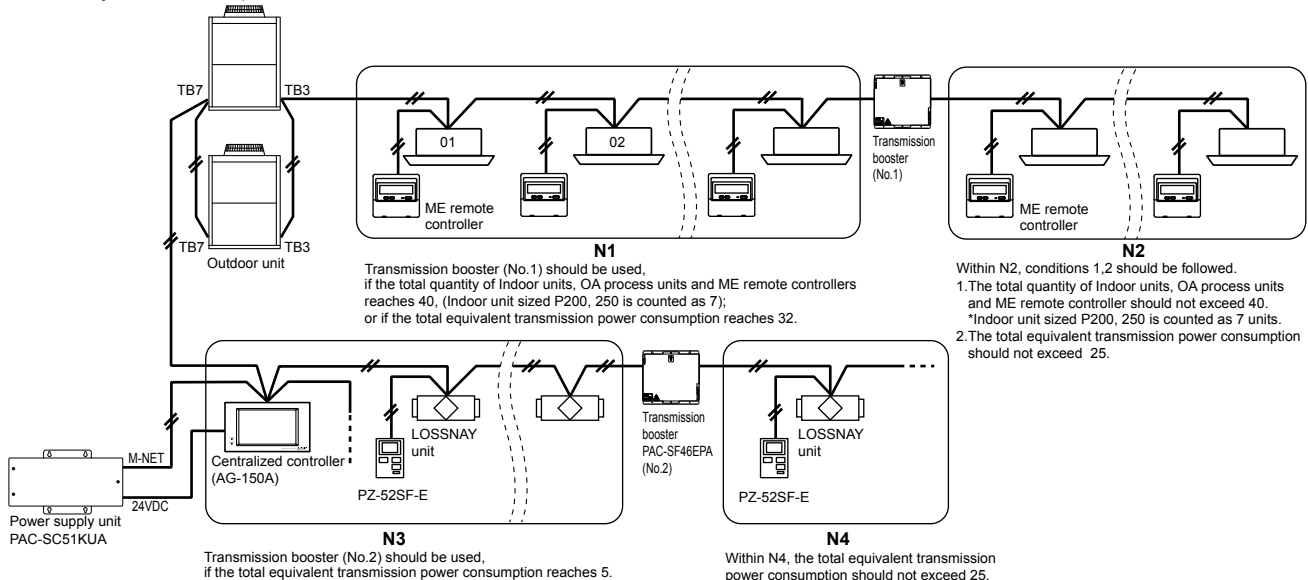

2. M-NET control

2-3-3. Ensuring proper power supply to System controller

The power to System controller (excluding LMAP02-E) is supplied via M-NET transmission line. M-NET transmission line at TB7 side is called Centralized control transmission line while one at TB3 side is called Indoor-Outdoor transmission line. There are 3 ways to supply power to the System controller .

- A) Connecting to TB3 of the Outdoor unit and receiving power from the Outdoor unit.
- B) Connecting to TB7 of the Outdoor unit and receiving power from the Outdoor unit.
- C) Connecting to TB7 of the Outdoor unit but receiving power from power supply unit PAC-SC51KUA.

2-3-3-A. When connecting to TB3 of the Outdoor unit and receiving power from the Outdoor unit.

Maximum 3 System controllers can be connected to TB3. If there is more than 1 Outdoor unit, it is necessary to replace power supply switch connector CN41 with CN40 on one Outdoor unit.

Fig. 2-3-3-A

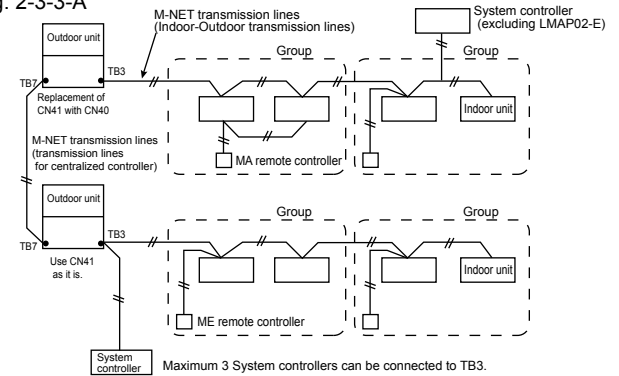

2-3-3-B. When connecting to TB7 of the Outdoor unit and receiving power from the Outdoor unit.

Maximum 3 System controllers can be connected to TB7 and receiving power from the Outdoor unit. It is necessary to replace power supply switch connector CN41 with CN40 on one Outdoor unit.

Fig. 2-3-3-B

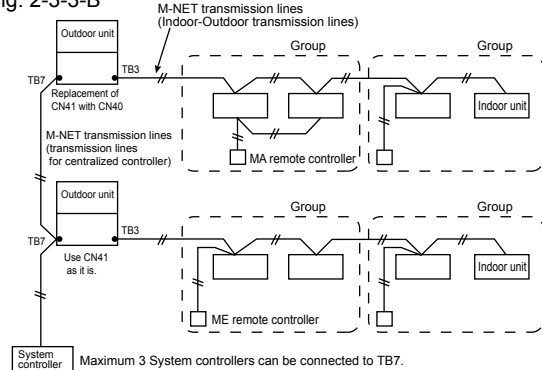

2-3-3-C. When connecting to TB7 of the Outdoor unit but receiving power from PAC-SC51KUA.

When using PAC-SC51KUA to supply transmission power, the power supply connector CN41 on the Outdoor units should be kept as it is. It is also a factory setting. 1 PAC-SC51KUA supports maximum 1 AG-150A unit due to the limited power 24VDC at its TB3.

However, 1 PAC-SC51KUA supplies transmission power at its TB2 equal to 5 Indoor units, which is referable at Table 2-3-2.

If PZ-52SF-E, Timers, System controller, ON/OFF controller connected to TB7 consume transmission power more than 5 (Indoor units), Transmission booster PAC-SF46EPA is needed. PAC-SF46EPA supplies transmission power equal to 25 Indoor units.

Fig. 2-3-3-C

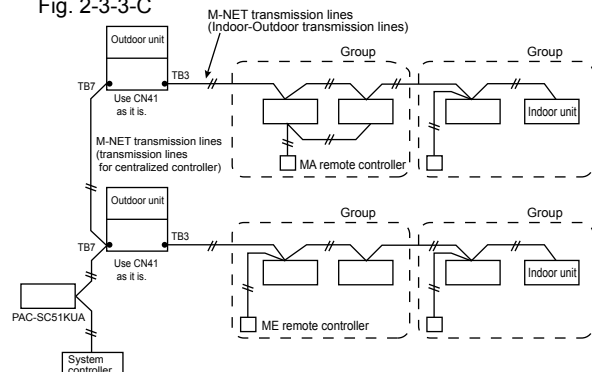

CAUTION

AG-150A*1 is recommended to connect to TB7 because it performs back-up to a number of data.

In an air conditioner system has more than 1 Outdoor units, AG-150A receiving transmission power through TB7 on one of the Outdoor units would have a risk that the connected Outdoor unit failure would stop power supply to AG-150A, and disrupt the whole system.

When applying apportioned electric power function, AG-150A is necessary to connected to TB7 and has its own power supply unit PAC-SC51KUA.*2

*1: AG-150A is an example model of system controllers.

*2: Power supply unit PAC-SC51KUA is for AG-150A.

2. M-NET control

2-3-4. Power supply to LM adapter LMAP02-E

1-phase 220-240VAC power supply is needed.

The power supply unit PAC-SC51KUA is not necessary when connecting only the LMAP02-E. Yet, make sure to change the power supply changeover connector CN41 to CN40 on the LM adapter.

2-3-5. Power supply to expansion controller

1-phase 100-240VAC power supply is needed.

The power supply unit PAC-SC51KUA is not necessary.

The expansion controller supplies power through TB3, which equals 6 indoor units. (refer to Table 2-3-2)

2-3-6. Power supply to BM ADAPTER

1-phase 100-240VAC power supply is needed.

The power supply unit PAC-SC51KUA is not necessary when only BM ADAPTER is connected.

Yet, make sure to move the power jumper from CN41 to CN40 on the BM ADAPTER.

2-3-7. Power supply to GB-50ADA

1-phase 100-240VAC power supply is needed.

The power supply unit PAC-SC51KUA is not necessary.

GB-50ADA supplies power through TB3, which equals 6 indoor units. (refer to Table 2-3-2)

2. M-NET control

2-4. Address setting

2-4-1. Switch operation

In order to constitute CITY MULTI in a complete system, switch operation for setting the unit address No. and connection No. is required.

① Address No. of outdoor unit, indoor unit and remote controller.

The address No. is set at the address setting board.

In the case of R2 system, it is necessary to set the same No. at the branch No. switch of indoor unit as that of the BC controller connected. (When connecting two or more branches, use the lowest branch No.)

② Caution for switch operations

- Be sure to shut off power source before switch setting. If operated with power source on, switch can not operate properly.
- No units with identical unit address shall exist in one whole air conditioner system. If set erroneously, the system can not operate.

③ MA remote controller

- When connecting only one remote controller to one group, it is always the main remote controller. When connecting two remote controllers to one group, set one remote controller as the main remote controller and the other as the sub remote controller.
- The factory setting is "Main".

PAR-21MAA

The MA remote controller does not have the switches listed above.
Refer to the installation manual for the function setting.

PAC-YT51CRB

Setting the dip switches

There are switches on the front of the remote controller. Remote controller Main/Sub and other function settings are performed using these switches. Ordinarily, only change the Main/Sub setting of SW1.
(The factory settings are all "ON".)

SW No	SW contents	ON	OFF	Comment
1	Remote controller Main/Sub setting	Main	Sub	Set one of the two remote controllers at one group to "Main"
2	Temperature display units setting	Celsius	Fahrenheit	When the temperature is displayed in [Fahrenheit], set to "No".
3	Cooling/heating display in AUTO mode	Yes	No	When you do not want to display "Cooling" and "Heating" in the Auto mode, set to "No".

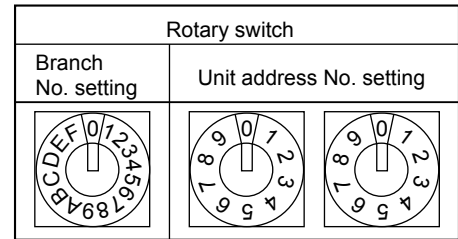

2. M-NET control

2-4-2. Rule of setting address

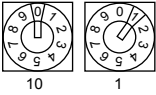
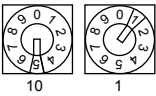
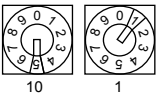
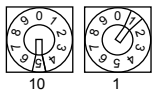
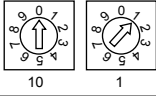
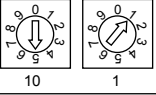
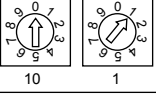
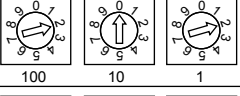
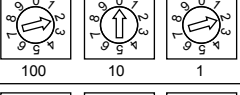
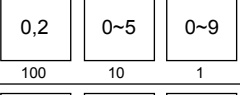
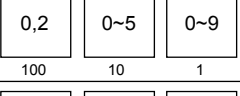
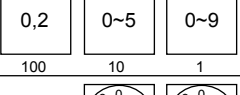
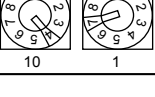
Unit	Address setting	Example	Note	
Indoor unit	01 ~ 50		Use the most recent address within the same group of indoor units. Make the indoor units address connected to the BC controller (Sub) larger than the indoor units address connected to the BC controller (Main). If applicable, set the sub BC controllers in an PURY system in the following order: (1) Indoor unit to be connected to the BC controller (Main) (2) Indoor unit to be connected to the BC controller (No.1 Sub) (3) Indoor unit to be connected to the BC controller (No.2 Sub) Set the address so that (1)<(2)<(3)	
Outdoor unit	51 ~ 99, 100 (Note1)		The smallest address of indoor unit in same refrigerant system + 50 Assign sequential address numbers to the outdoor units in one refrigerant circuit system. OC, OS1 and OS2 are automatically detected. (Note 2) * Please reset one of them to an address between 51 and 99 when two addresses overlap. * The address automatically becomes "100" if it is set as "01~ 50"	
BC controller (Main)	52 ~ 99, 100		The address of outdoor unit + 1 * Please reset one of them to an address between 51 and 99 when two addresses overlap. * The address automatically becomes "100" if it is set as "01~ 50"	
BC controller (Sub)	52 ~ 99, 100		Lowest address within the indoor units connected to the BC controller (Sub) plus 50.	
Local remote controller	ME, LOSSNAY Remote controller (Main)	101 ~ 150 Fixed		The smallest address of indoor unit in the group + 100 * The place of "100" is fixed to "1"
	ME, LOSSNAY Remote controller (Sub)	151 ~ 199, 200 Fixed		The address of main remote controller + 50 * The address automatically becomes "200" if it is set as "00"
System controller	Group remote controller	201 ~ 250 Fixed		The smallest group No. to be managed + 200
	System remote controller	000, 201 ~ 250		
	ON/OFF remote controller	000, 201 ~ 250		The smallest group No. to be managed + 200 * The smallest group No. to be managed is changeable.
	AG-150A GB-50ADA AT-50A	000, 201 ~ 250		
	PAC-YG50ECA	000, 201 ~ 250		* Settings are made on the initial screen of AG-150A.
	BAC-HD150	000, 201 ~ 250		* Settings are made with setting tool of BM ADAPTER.
LMAP02-E	201 ~ 250 Fixed			

Note1: To set the address to "100", set it to "50"

Note2: Outdoor units OC, OS1 and OS2 in one refrigerant circuit system are automatically detected.

OC, OS1 and OS2 are ranked in descending order of capacity. If units are the same capacity, they are ranked in ascending order of their address.

2. M-NET control

2-4-3. System examples

Factory setting

Original switch setting of the outdoors, indoors, controllers, LMAP and BM ADAPTER at shipment is as follows.

- Outdoor unit : Address: 00, CN41: U (Jumper), DipSW2-1: OFF
- Indoor unit : Address: 00
- ME remote controller : Address: 101
- LMAP : Address: 247, CN41: U (Jumper), DipSW1-2: OFF
- BM ADAPTER : Address: 00

Setting at the site

- DipSW2-1(Outdoor) : When the System Controller is used, all the Dip SW2-1 at the outdoor units should be set to "ON". * Dip SW2-1 remains OFF when only LMAP02-E is used.
- DipSW1-2(LMAP) : When the LMAP is used together with System Controller, DipSW1-2 at the LMAP should be set to "ON".
- CN40/CN41 : Change jumper from CN41 to CN 40 at outdoor control board will activate central transmission power supply to TB7;
(Change jumper at only one outdoor unit when activating the transmission power supply without using a power supply unit.)
Change jumper from CN41 to CN 40 at LMAP will activate transmission power supply to LMAP itself;
Power supply unit is recommended to use for a system having more than 1 outdoor unit, because the central transmission power supply from TB7 of one of outdoor units is risking that the outdoor unit failure may let down the whole system controller system.

2-4-3-1. MA remote controller, Single-refrigerant-system, No System Controller

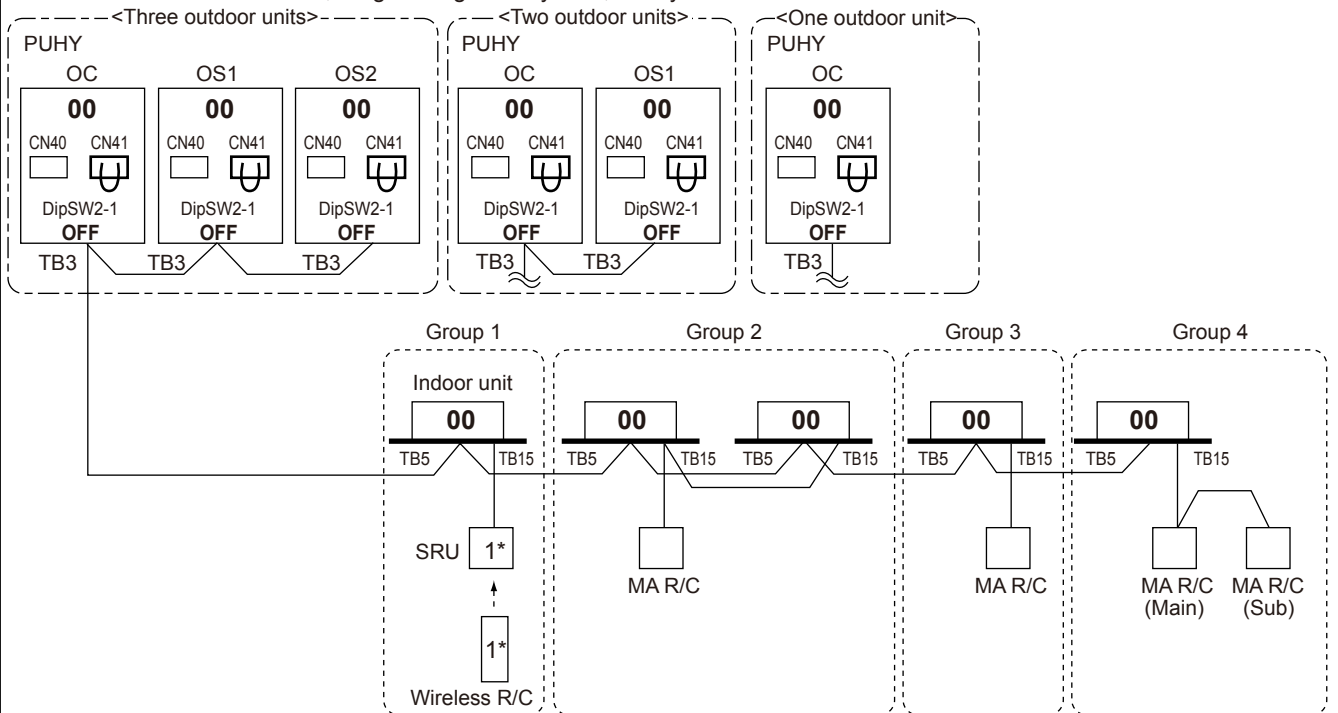

*1 For Wireless R/C and Signal receiver unit (SRU), channel 1, 2 and 3 are selectable and should be set to same channel.

NOTE:

1. Outdoor units OC, OS1 and OS2 in one refrigerant circuit system are automatically detected. OC, OS1 and OS2 are ranked in descending order of capacity. If units are the same capacity, they are ranked in ascending order of their address.
2. No address setting is needed.
3. For a system having more than 32 indoor unit (P15-P140), confirm the need of Booster at 2-3 "System configuration restrictions".

2. M-NET control

2-4-3. System examples

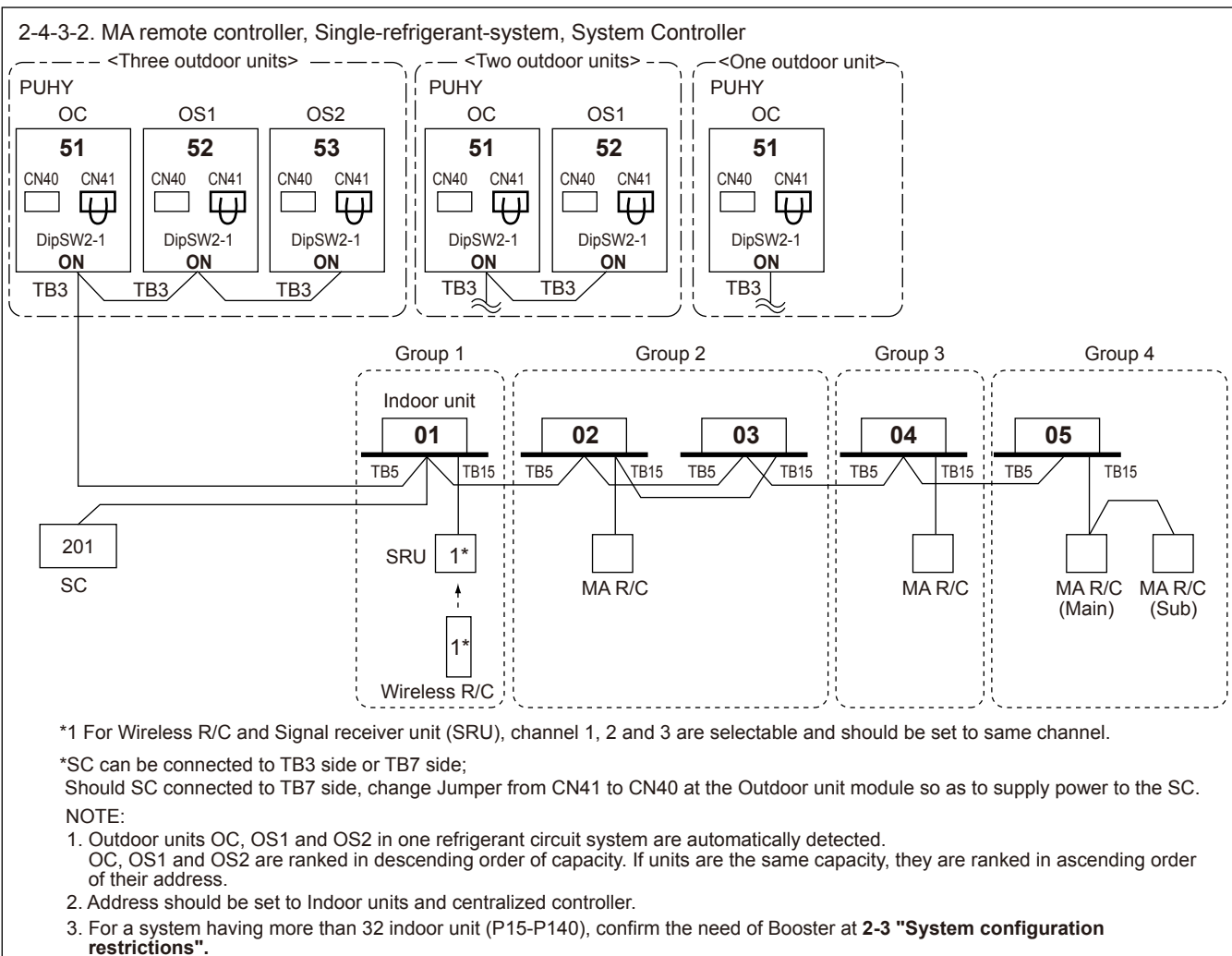

2. M-NET control

2-4-3. System examples

2-4-3-3. MA remote controller, Multi-refrigerant-system, System Controller at TB7/TB3 side, Booster for long M-NET wiring

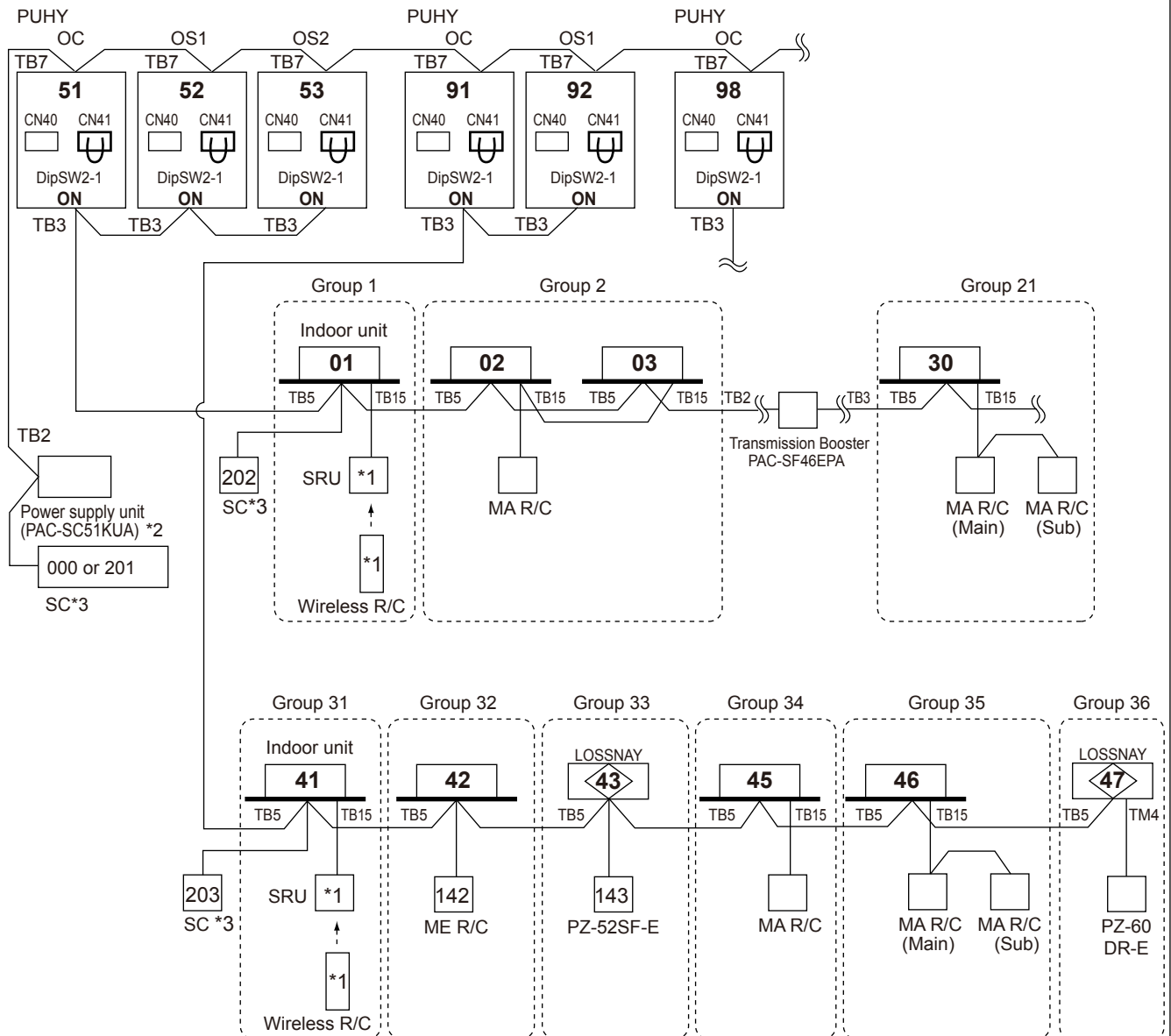

*1 For Wireless R/C and Signal receiver unit (SRU), channel 1, 2 and 3 are selectable and should be set to same channel.

*2 System controller should connect to TB7 at Outdoor and use power supply unit together in Multi-Refrigerant-System. For AG-150A, 24V DC should be used with the PAC-SC51KUA.

*3 When multiple system controllers are connected in the system, set the controller with more functions than others as a "main" controller and others as "sub".
Make the setting to only one of the system controllers for "prohibition of operation from local remote controller".

NOTE:

- Outdoor units OC, OS1 and OS2 in one refrigerant circuit system are automatically detected. OC, OS1 and OS2 are ranked in descending order of capacity. If units are the same capacity, they are ranked in ascending order of their address.
- Address should be set to Indoor units, LOSSNAY and system controller.
- M-NET power is supplied by the Outdoor unit at TB3, while Indoor unit and ME remote controller consume the M-NET power for transmission use. The power balance is needed to consider for long M-NET wiring. Details refer to 2-3 "System configuration restrictions".

2. M-NET control

2-4-3. System examples

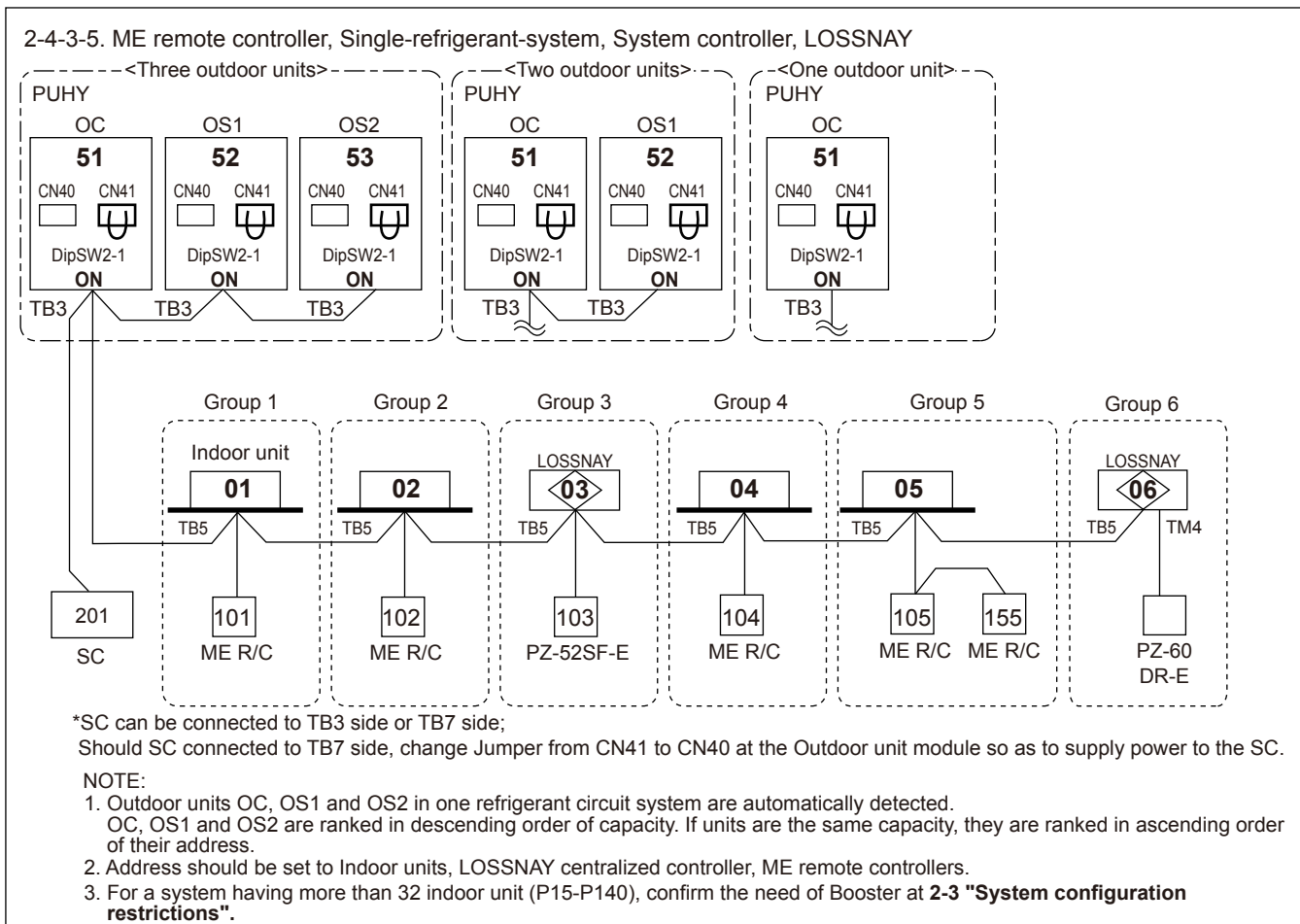
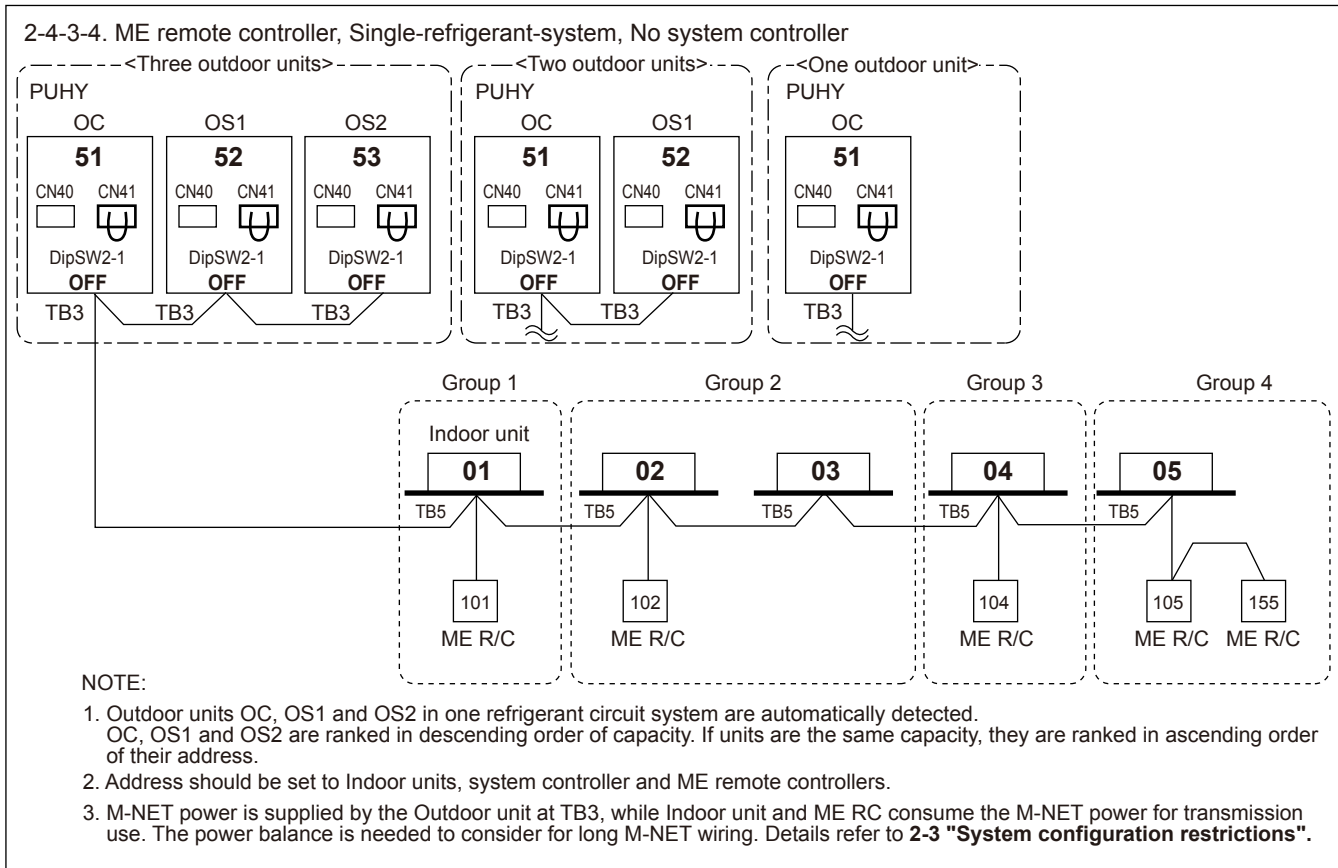

2. M-NET control

2-4-3. System examples

2-4-3-6. ME remote controller, Multi-refrigerant-system, System Controller at TB 7side, LOSSNAY, Booster for long M-NET wiring

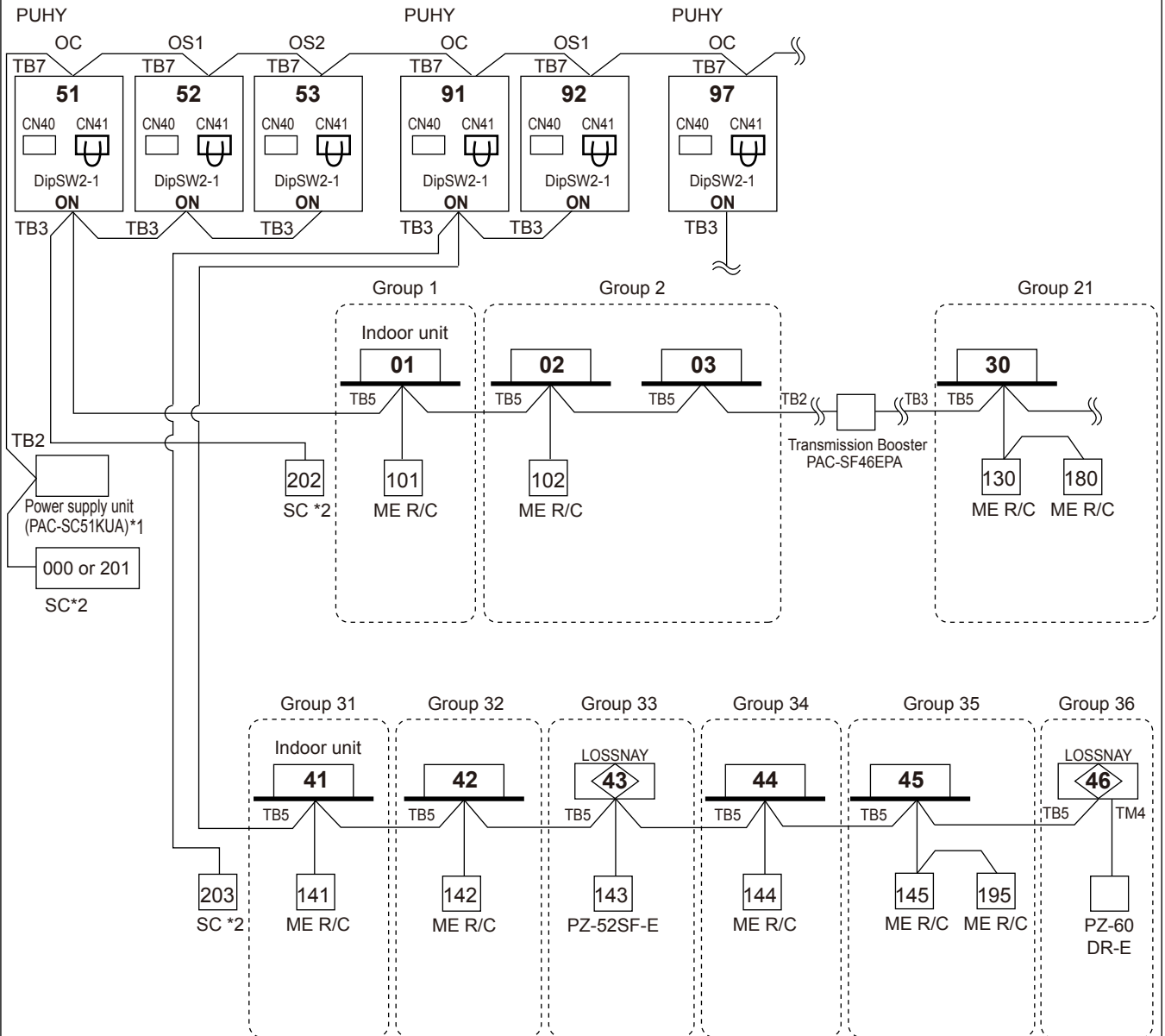

*1 System controller should connect to TB7 at Outdoor and use power supply unit together in Multi-Refrigerant-System.
For AG-150A, 24V DC should be used with the PAC-SC51KUA.

*2 When multiple system controllers are connected in the system, set the controller with more functions than others as a "main" controller and others as "sub".
Make the setting to only one of the system controllers for "prohibition of operation from local remote controller".

NOTE:

- Outdoor units OC, OS1 and OS2 in one refrigerant circuit system are automatically detected.
OC, OS1 and OS2 are ranked in descending order of capacity. If units are the same capacity, they are ranked in ascending order of their address.
- M-NET power is supplied by the Outdoor unit at TB3, while Indoor unit and ME remote controller consume the M-NET power for transmission use. The power balance is needed to consider for long M-NET wiring. Details refer to 2-3 "System configuration restrictions".

2. M-NET control

2-4-3-7. ME remote controller, Multi-refrigerant-system, No Power supply unit

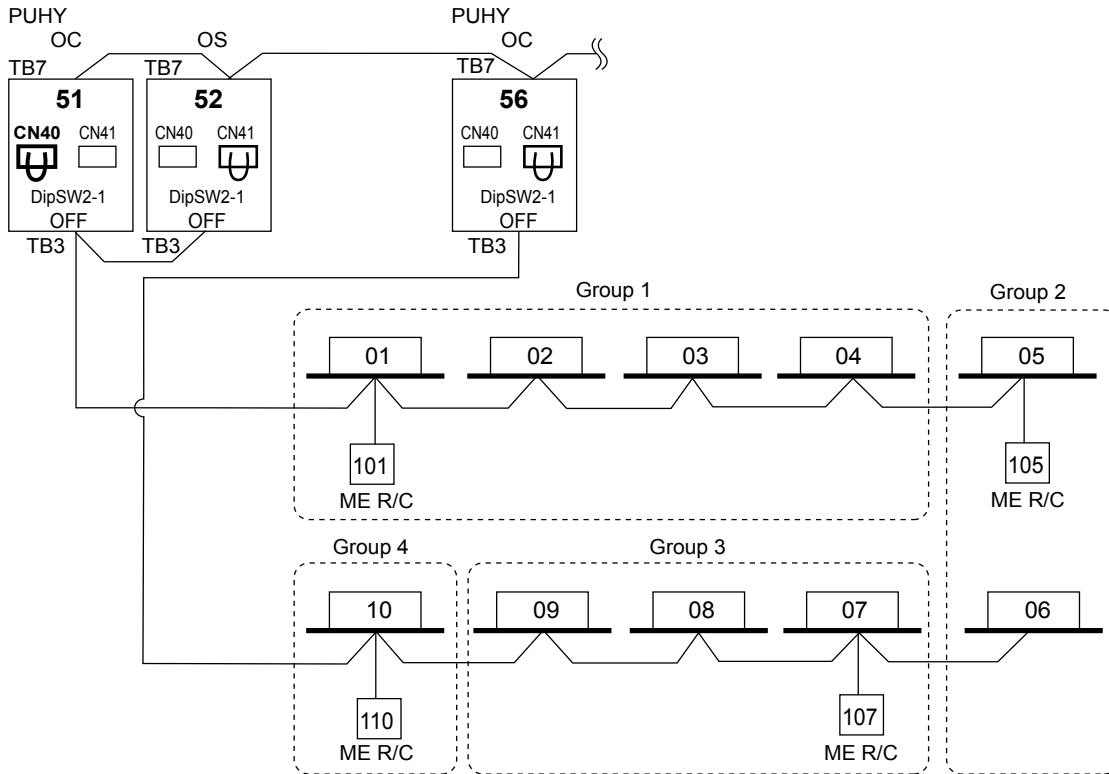

NOTE

- It is necessary to change the connector to CN40 on the outdoor unit control board (only one outdoor unit) when the group is set between other refrigerant systems.
- It is necessary to set on the remote controller by manual when group sets on the different refrigerant system. Please refer to remote controller installation manual.

2-4-3-8. ME remote controller, Multi-refrigerant-system, System Controller at TB7 side, No Power supply unit

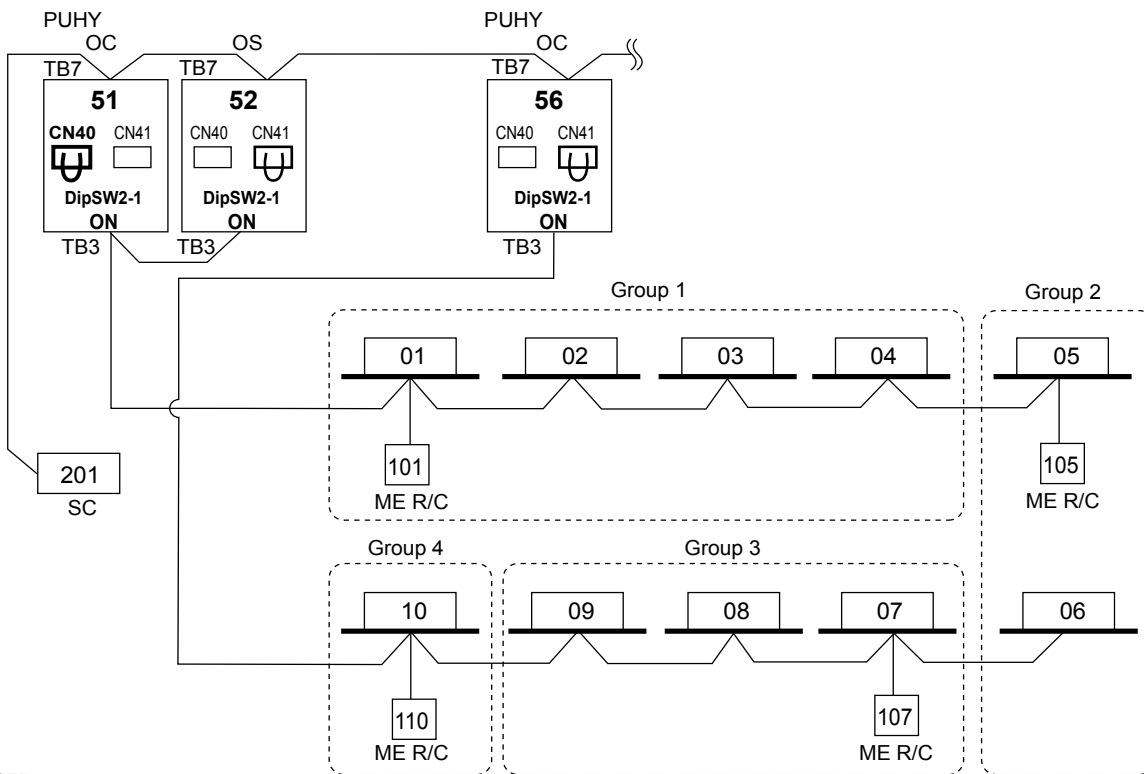

NOTE

- It is necessary to change the connector to CN40 on the outdoor unit control board (only one outdoor unit) when the group is set between other refrigerant systems.
- It is necessary to set on the remote controller by manual when group sets on the different refrigerant system. Please refer to remote controller installation manual.

2. M-NET control

2-4-3-9. TG-2000A(*1)+AG-150A*2

AG-150A can control max. 50 indoor units;

TG-2000A can control max. 40 AG-150A;*3

TG-2000A can control max. 2000 indoor units.

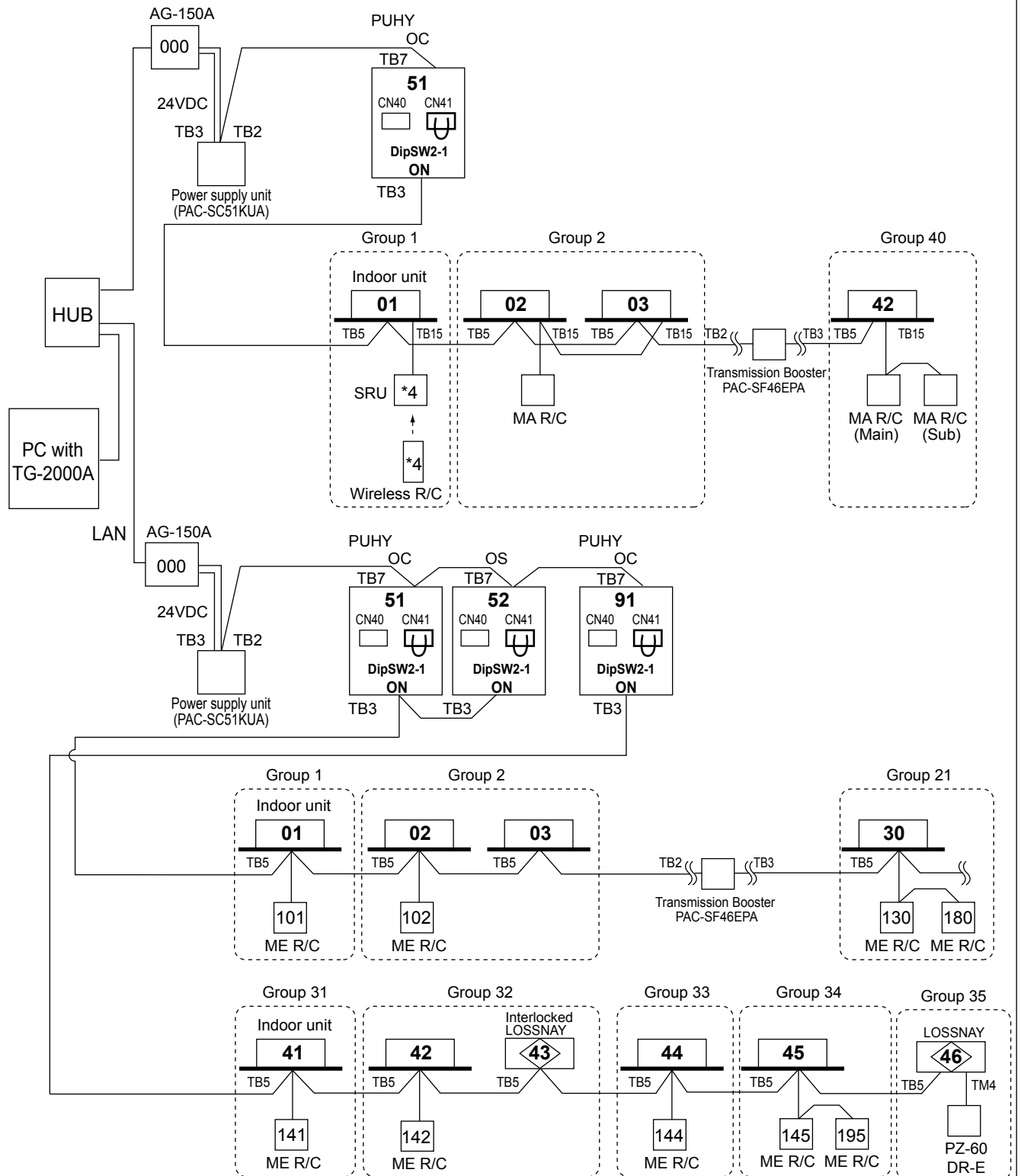

● It is planned that GB-50ADA will be supported on TG-2000A Ver. 6.3* or later.

*1 TG-2000A (Ver.5.5 or later) supports AG-150A (Ver.1 series).

TG-2000A (Ver. 6.1 or later) supports AG-150A (Ver. 2.1 or later) connected with the expansion controller (EC).

*2 AG-150A (Ver.1 series) does not support the expansion controller (EC).

*3 When AG-150A connected with the expansion controller (EC) is connected, the number of EC will be the maximum controllable number.

TG-2000A can control up to 40 EC or AG-150A without EC connection.

*4 For Wireless R/C and Signal receiver unit (SRU), channel 1, 2 and 3 are selectable and should be set to same channel.

2. M-NET control

2-4-3. System examples

2-4-3-10. AG-150A + PAC-YG50ECA (Expansion controller)

AG-150A can control max. 150 indoor units/ via expansion controllers.

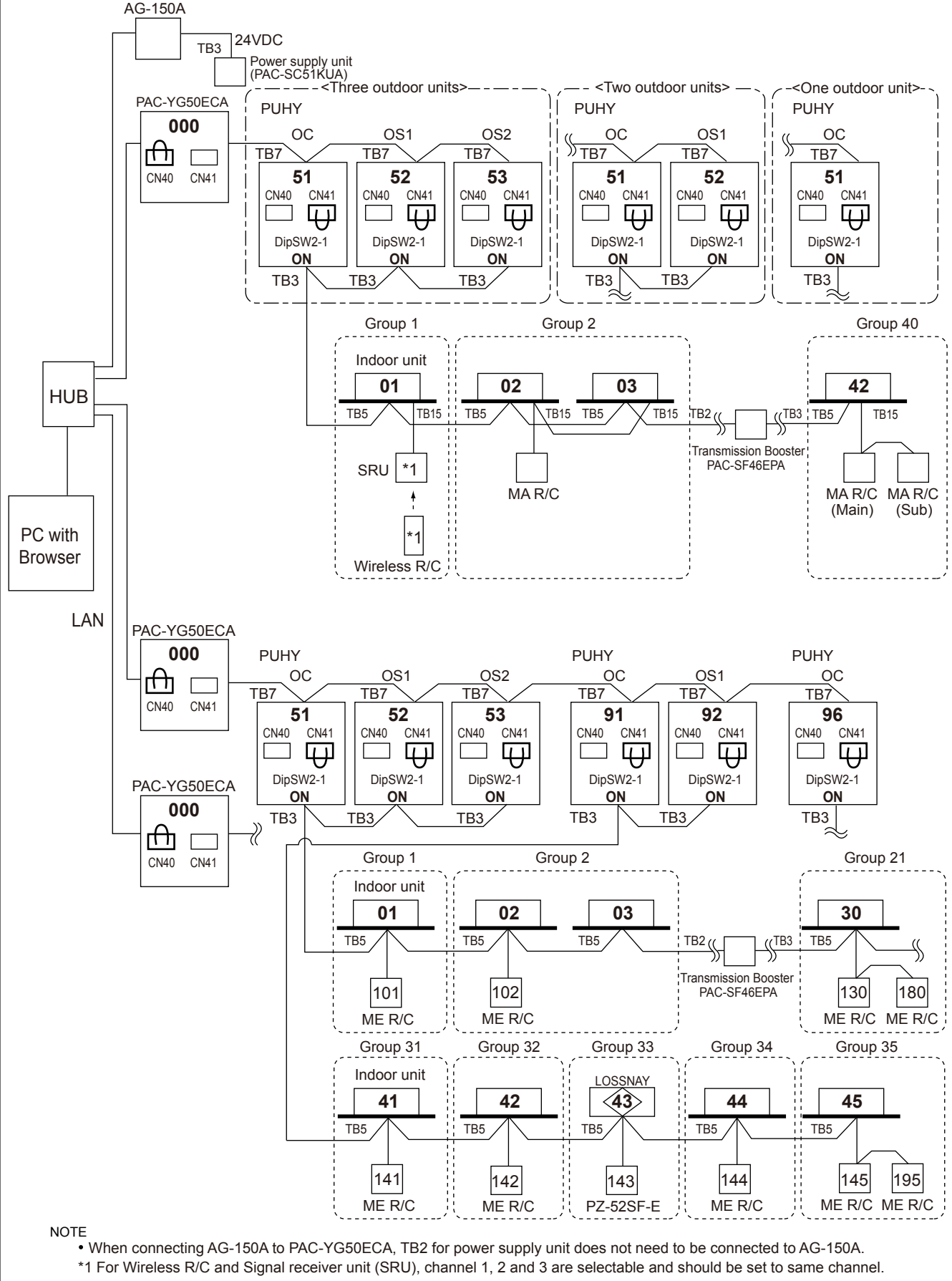

2. M-NET control

2-4-3. System examples

2-4-3-11. LMAP

LMAP can transmission for max. 50 indoor units;

If system controller (SC) is used, DipSW1-2 at LMAP and DipSW2-1 at Outdoor unit should set to "ON".

Change Jumper from CN41 to CN40 to activate power supply to LMAP itself for those LMAP connected without system controller (SC).

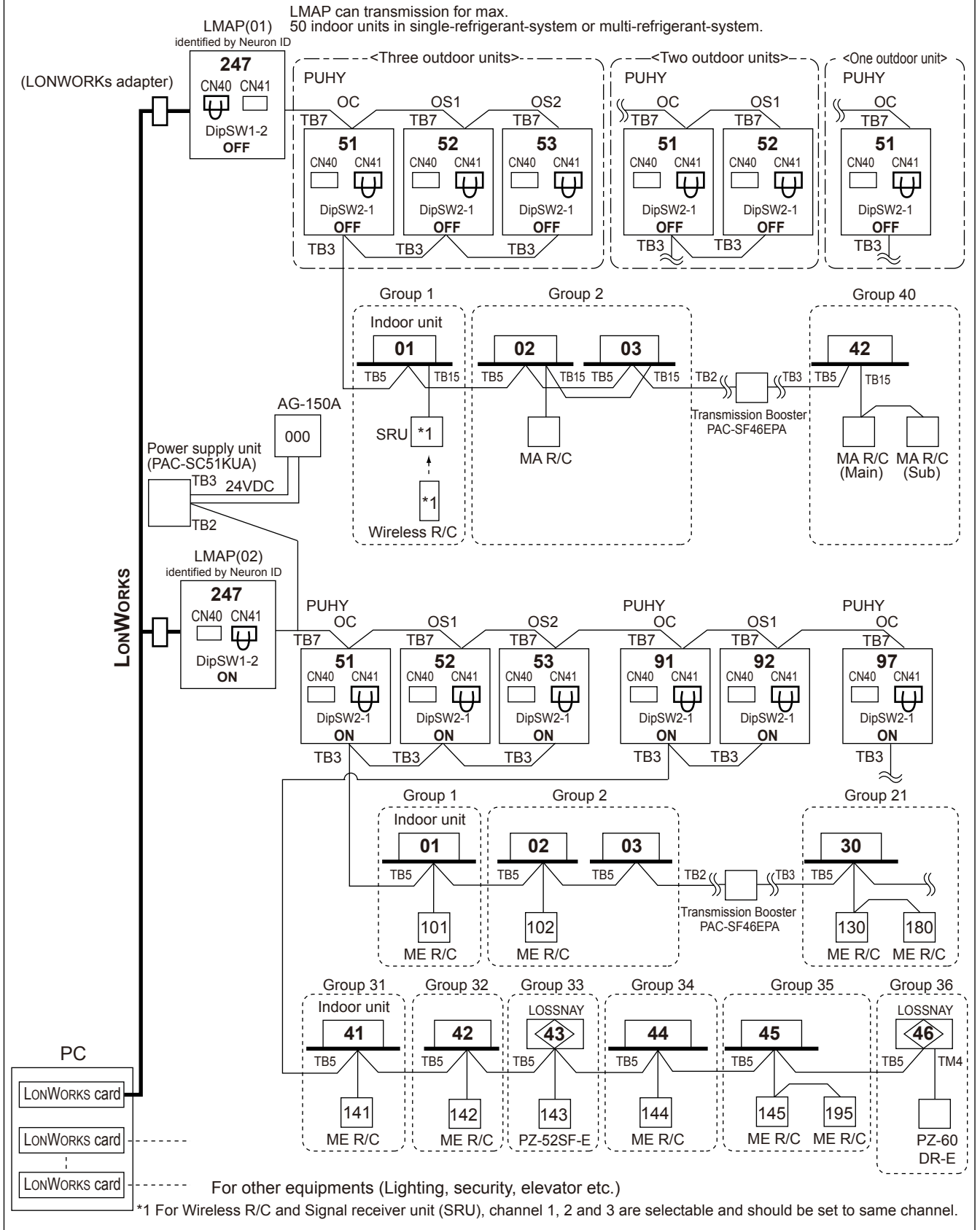

2. M-NET control

2-4-3. System examples

2-4-3-12. BM ADAPTER

BM ADAPTER can transmission for max. 50 indoor units;
Change Jumper from CN41 to CN40 to activate power supply to BM ADAPTER itself for those BM ADAPTER connected without the power supply unit.

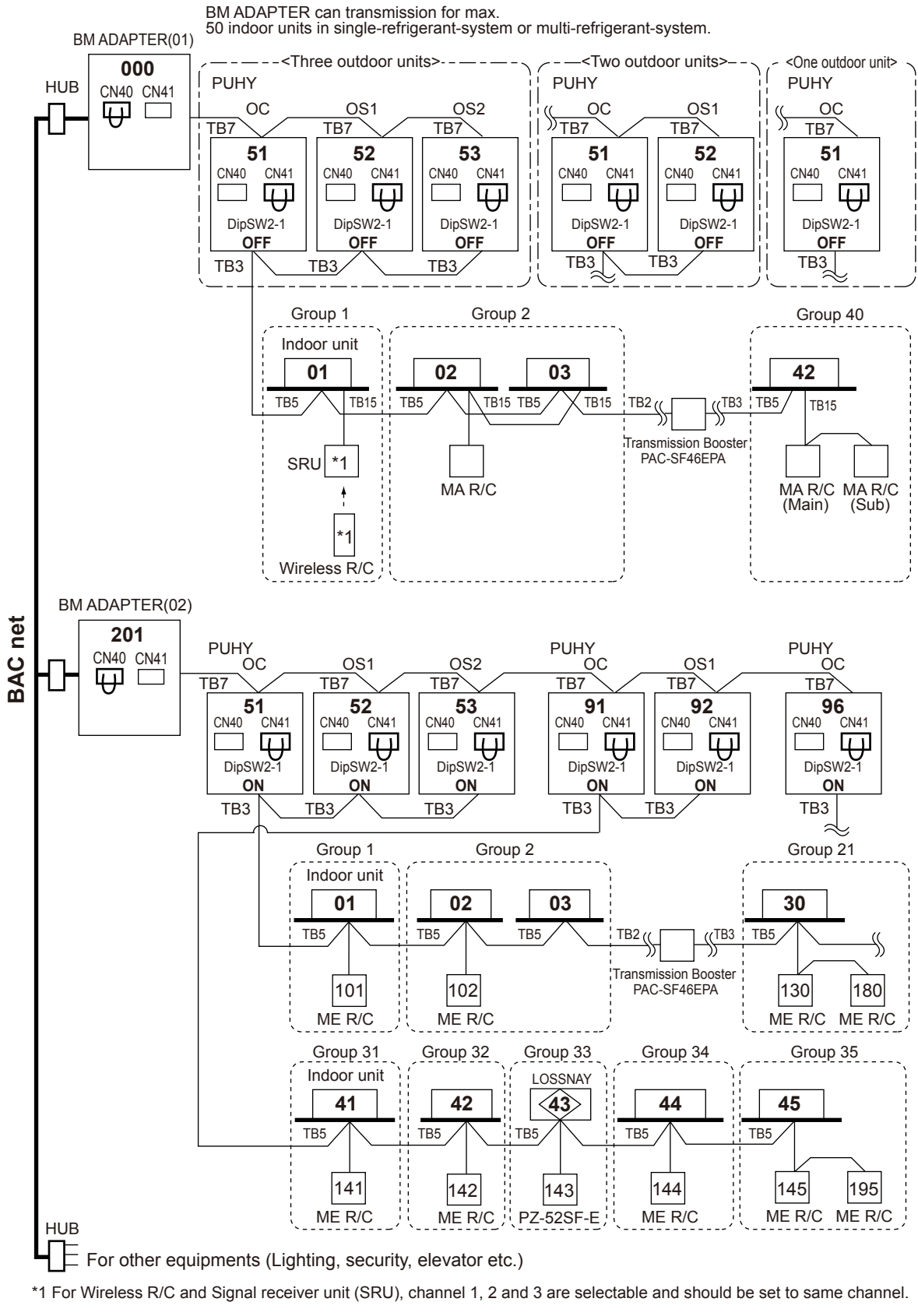

2. M-NET control

2-4-3. System examples

2-4-3-13. BM ADAPTER+PAC-YG50ECA (Expansion controller)

BM ADAPTER(*1) can transmission for max. 150 indoor units/via expansion controllers (PAC-YG50ECA).

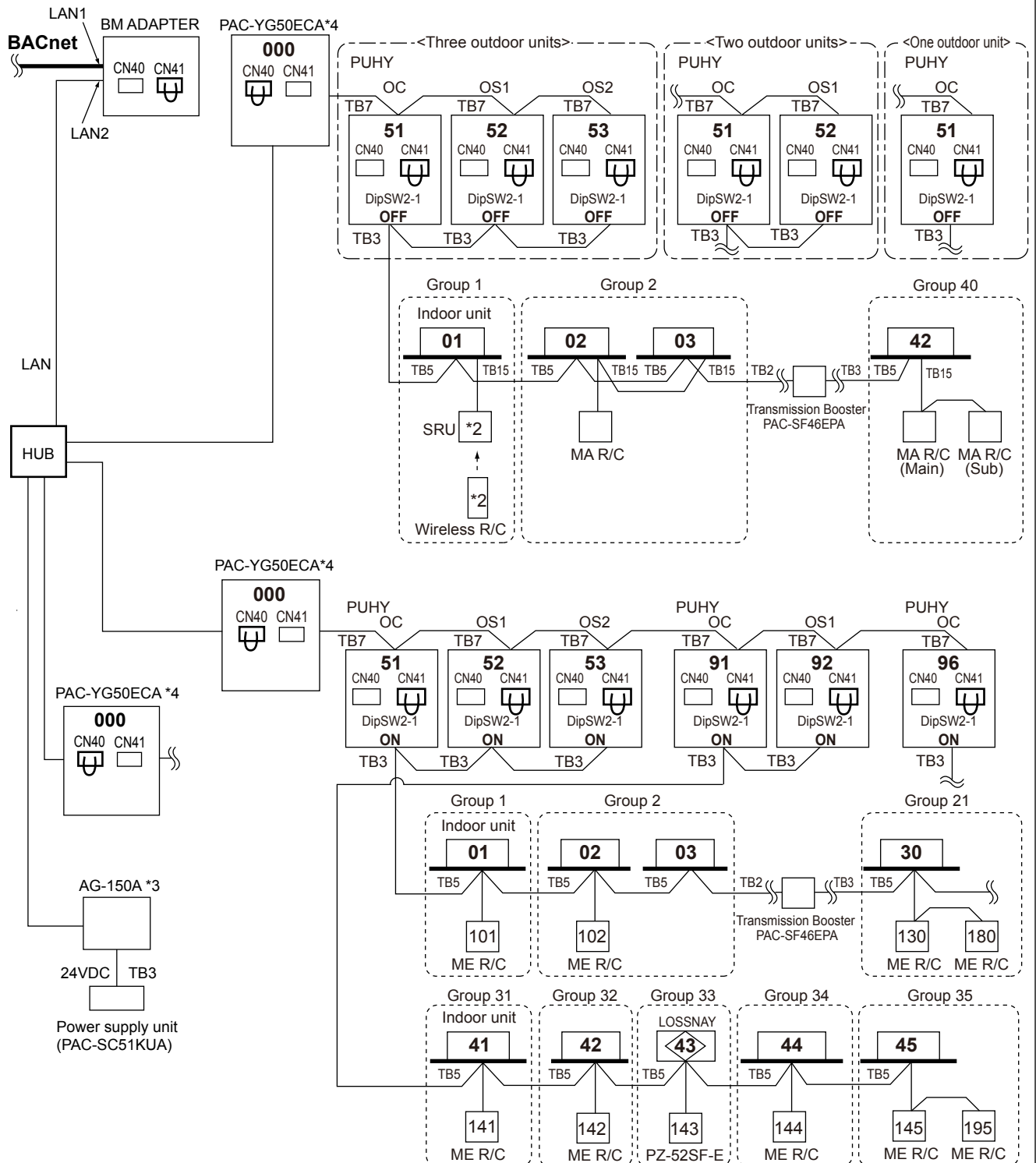

NOTE

•It is not necessary to connect the M-NET transmission line to the TB3 on BM ADAPTER. Leave the power jumper of BM ADAPTER connected to CN41.

*1 BM ADAPTER (Ver.2.00 or later) supports the expansion controller.

*2 For Wireless R/C and Signal receiver unit (SRU), channel 1, 2 and 3 are selectable and should be set to same channel.

*3 AG-150A (Ver.2.30 or later) supports the BM ADAPTER.

*4 PAC-YG50ECA (Ver.1.30 or later) supports the BM ADAPTER.

3. Piping Design

3-1. Piping Design

3-1-1. PUHY-RP200-350YJM-B

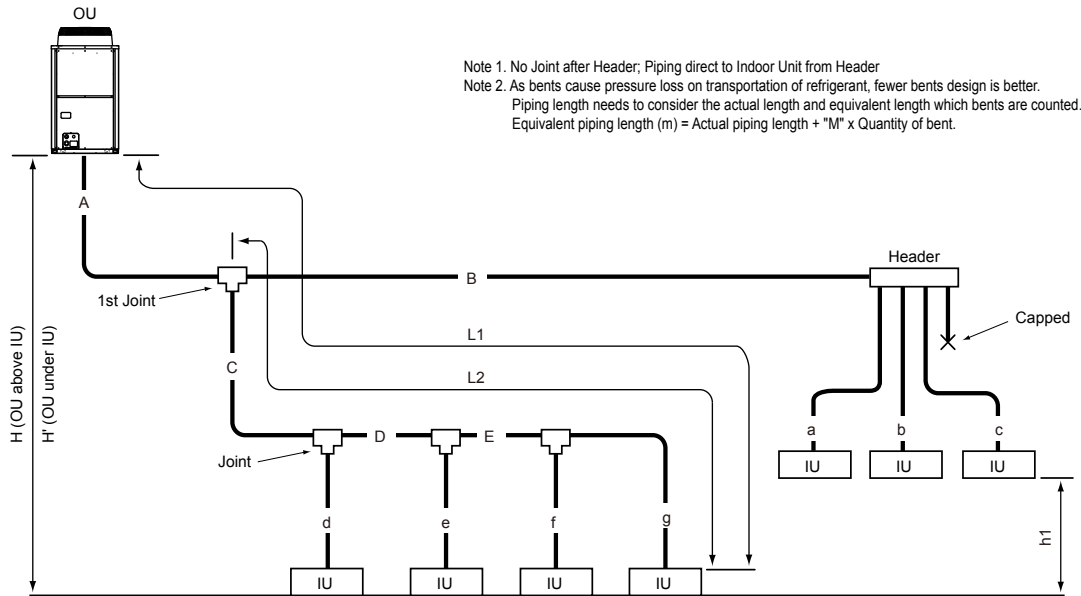

Note 1. No Joint after Header; Piping direct to Indoor Unit from Header
 Note 2. As bents cause pressure loss on transportation of refrigerant, fewer bents design is better.
 Piping length needs to consider the actual length and equivalent length which bents are counted.
 Equivalent piping length (m) = Actual piping length + "M" x Quantity of bent.

Fig. 3-1-1A Piping scheme

IU : Indoor unit, OU : Outdoor unit

Table 3-1-1-1. Piping length (m)

Item	Piping in the figure	Max. length	Max. equivalent length
Total piping length	A+B+C+D+E+a+b+c+d+e+f+g	300 *1	
Farthest IU from OU (L1)	A+C+D+E+g / A+B+c	120	150
Farthest IU from first joint (L2)	C+D+E+g / B+c	40 *2	
Height between OU and IU (OU above IU)	H	50	
Height between OU and IU (OU under IU)	H'	40	
Height between IU and IU	h1	15	

OU: Outdoor Unit, IU: Indoor Unit

* 1 Do not exceed the amount of refrigerant to be charged written below.

PUHY-RP200-250YJM-B: $0.39 \times L_0 + 0.29 \times L_1 + 0.2 \times L_2 + 0.12 \times L_3 + 0.06 \times L_4 + 0.024 \times L_5 < 18$
 PUHY-RP300-350YJM-B: $0.39 \times L_0 + 0.29 \times L_1 + 0.2 \times L_2 + 0.12 \times L_3 + 0.06 \times L_4 + 0.024 \times L_5 < 25$

L₀: Total length of ø22.2 liquid pipe (m)
 L₁: Total length of ø19.05 liquid pipe (m)
 L₂: Total length of ø15.88 liquid pipe (m)
 L₃: Total length of ø12.7 liquid pipe (m)
 L₄: Total length of ø9.52 liquid pipe (m)
 L₅: Total length of ø6.35 liquid pipe (m)

* 2 When creating 1 system out of the pipework of 2 systems, (L1-L2) must be 40 m or less.

L1: Distance between system 1's original outdoor unit and system 1's original farthest indoor unit.
 L2: Distance between system 2's original outdoor unit and system 2's original farthest indoor unit.
 L1 ≥ L2

Table 3-1-1-3. Piping "A" size selection rule (mm)

Outdoor	Pipe (Liquid)	Pipe (Gas)
PUHY-RP200YJM-B	ø12.7	ø28.58
PUHY-RP250YJM-B	ø12.7	ø28.58
PUHY-RP300YJM-B	ø12.7	ø28.58
PUHY-RP350YJM-B	ø15.88	ø34.93

Table 3-1-1-4. R410A piping "B", "C", "D", "E" size selection rule (mm [in.])

Total down-stream Indoor capacity	Pipe (Liquid)	Pipe (Gas)
~ P80	ø9.52 [3/8"]	ø15.88 [5/8"]
P81 ~ P160	ø12.7 [1/2"]	ø19.05 [3/4"]
P161 ~ P330	ø12.7 [1/2"]	ø25.4 [1"]
P331 ~ P630	ø15.88 [5/8"]	ø34.93 [1-3/8"]
P631 ~	ø19.05 [3/4"]	ø41.28 [1-5/8"]

Table 3-1-1-5. Piping "a", "b", "c", "d", "e", "f", "g" size selection rule (mm [in.])

Indoor Unit size	Pipe (Liquid)	Pipe (Gas)
P20, P25, P32, P40	ø6.35 [1/4"]	ø12.70 [1/2"]
P50, P63, P71, P80	ø9.52 [3/8"]	ø15.88 [5/8"]
P140	ø9.52 [3/8"]	ø19.05 [3/4"]
P200	ø12.7 [1/2"]	ø25.4 [1"]
P250	ø12.7 [1/2"]	ø28.58 [1-1/8"]

Note 3. Indoor capacity is described as its model size.
 For example, PEFY-P32VMM-E, its capacity is P32.

Note 4. Total down-stream Indoor capacity is the summary of the model size of Indoors downstream.
 For example, PEFY-P25VMM-E + PEFY-P32VMM-E: Total Indoor capacity = P25 + P32 = P57

Note 5. Piping size determined by the Total down-stream indoor capacity is NOT necessary to be bigger than the up-stream one.
 i.e. A ≥ B; A ≥ C ≥ D

3. Piping Design

3-1-2. PUHY-RP400-550YSJM-B

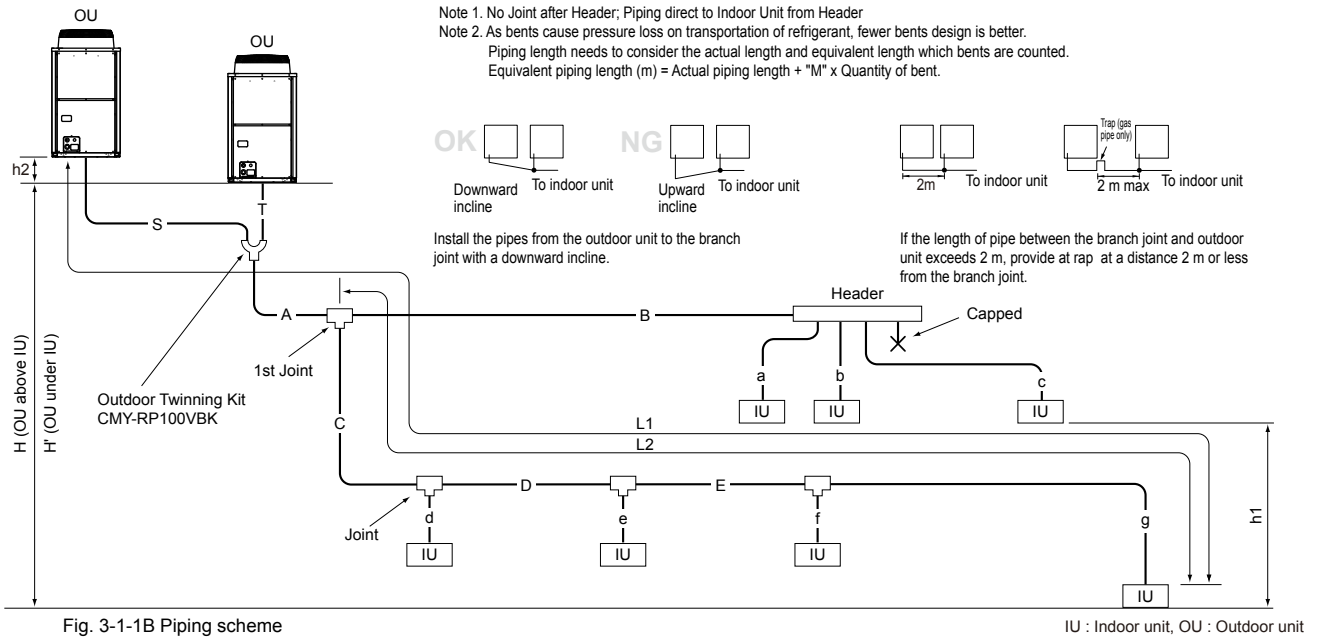

Fig. 3-1-1B Piping scheme

IU : Indoor unit, OU : Outdoor unit

Table 3-1-2-1. Piping length (m)

Item	Piping in the figure	Max. length	Max. equivalent length
Total piping length	S+T+A+B+C+D+E+a+b+c+d+e+f+g	300 *1	
Distance between OU and OU	S+T	10	
Height between OU and OU	h2	0.1	
Farthest IU from OU (L1)	S(T)+A+C+D+E+g / S(T)+A+B+c	120	150
Farthest IU from the first Joint (L2)	C+D+E+g / B+c	40 *2	
Height between OU and IU (OU above IU)	H	50	
Height between OU and IU (OU under IU)	H'	40	
Height between IU and IU	h1	15	

OU: Outdoor Unit, IU: Indoor Unit

Table 3-1-2-2. Bent equivalent length "M"

Outdoor unit model	M (m/bent)
PUHY-RP400YSJM-B	0.50
PUHY-RP450YSJM-B	0.50
PUHY-RP500YSJM-B	0.50
PUHY-RP550YSJM-B	0.50

* 1 Do not exceed the amount of refrigerant to be charged written below.

$$\text{PUHY-RP400-550YSJM-B: } 0.39 \times L_0 + 0.29 \times L_1 + 0.2 \times L_2 + 0.12 \times L_3 + 0.06 \times L_4 + 0.024 \times L_5 < 25$$

L₀: Total length of ø22.2 liquid pipe (m)

L₁: Total length of ø19.05 liquid pipe (m)

L₂: Total length of ø15.88 liquid pipe (m)

L₃: Total length of ø12.7 liquid pipe (m)

L₄: Total length of ø9.52 liquid pipe (m)

L₅: Total length of ø6.35 liquid pipe (m)

* 2 When creating 1 system out of the pipework of 2 systems, (L1-L2) must be 40 m or less.

L1: Distance between system 1's original outdoor unit and system 1's original farthest indoor unit.

L2: Distance between system 2's original outdoor unit and system 2's original farthest indoor unit.

L1 ≥ L2

Table 3-1-2-3. Piping "A" size selection rule (mm)

Outdoor	Pipe (Liquid)	Pipe (Gas)
PUHY-RP400YSJM-B	ø15.88	ø34.93
PUHY-RP450YSJM-B	ø15.88	ø34.93
PUHY-RP500YSJM-B	ø15.88	ø34.93
PUHY-RP550YSJM-B	ø15.88	ø34.93

Table 3-1-2-4. Piping "B", "C", "D", "E" size selection rule (mm [in.])

Total down-stream Indoor capacity	Pipe (Liquid)	Pipe (Gas)
~ P80	ø9.52 [3/8"]	ø15.88 [5/8"]
P81 ~ P160	ø12.7 [1/2"]	ø19.05 [3/4"]
P161 ~ P330	ø12.7 [1/2"]	ø25.4 [1"]
P331 ~ P630	ø15.88 [5/8"]	ø34.93 [1-3/8"]
P631 ~	ø19.05 [3/4"]	ø41.28 [1-5/8"]

Table 3-1-2-5. Piping "a", "b", "c", "d", "e", "f", "g" size selection rule (mm [in.])

Indoor Unit size	Pipe (Liquid)	Pipe (Gas)
P20, P25, P32, P40	ø6.35 [1/4"]	ø12.70 [1/2"]
P50, P63, P71, P80	ø9.52 [3/8"]	ø15.88 [5/8"]
P140	ø9.52 [3/8"]	ø19.05 [3/4"]
P200	ø12.7 [1/2"]	ø25.4 [1"]
P250	ø12.7 [1/2"]	ø28.58 [1-1/8"]

Note 3. Indoor capacity is described as its model size.

For example, PEFY-P32VMM-E, its capacity is P32.

Note 4. Total down-stream Indoor capacity is the summary of the model size of Indoors downstream.

For example, PEFY-P25VMM-E + PEFY-P32VMM-E: Total Indoor capacity = P25 + P32 = P57

Note 5. Piping size determined by the Total down-stream indoor capacity is NOT necessary

to be bigger than the up-stream one.

i.e. A >= B; A >= C >= D

3. Piping Design

3-1-3. PUHY-RP600-650YSJM-B

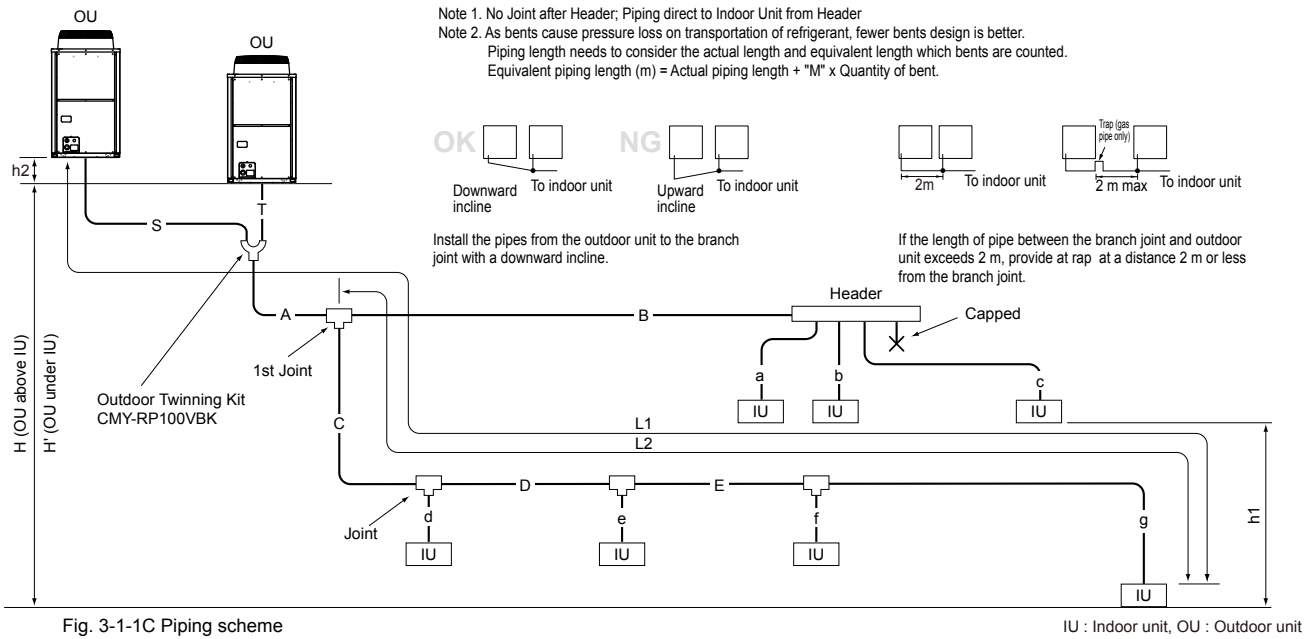

Fig. 3-1-1C Piping scheme

Item	Piping in the figure	Max. length	Max. equivalent length
Total piping length	S+T+A+B+C+D+E+a+b+c+d+e+f+g	250 *1	
Distance between OU and OU	S+T	10	
Height between OU and OU	h2	0.1	
Farthest IU from OU (L1)	S(T)+A+C+D+E+g / S(T)+A+B+c	120	150
Farthest IU from the first Joint (L2)	C+D+E+g / B+c	40 *2	
Height between OU and IU (OU above IU)	H	50	
Height between OU and IU (OU under IU)	H'	40	
Height between IU and IU	h1	15	

Outdoor unit model	M (m/bent)
PUHY-RP600YSJM-B	0.50
PUHY-RP650YSJM-B	0.50

OU: Outdoor Unit, IU: Indoor Unit

* 1 Do not exceed the amount of refrigerant to be charged written below.
 PUHY-RP600-650YSJM-B: $0.39 \times L_0 + 0.29 \times L_1 + 0.2 \times L_2 + 0.12 \times L_3 + 0.06 \times L_4 + 0.024 \times L_5 < 25$

L_0 : Total length of $\phi 22.2$ liquid pipe (m)
 L_1 : Total length of $\phi 19.05$ liquid pipe (m)
 L_2 : Total length of $\phi 15.88$ liquid pipe (m)
 L_3 : Total length of $\phi 12.7$ liquid pipe (m)
 L_4 : Total length of $\phi 9.52$ liquid pipe (m)
 L_5 : Total length of $\phi 6.35$ liquid pipe (m)

* 2 When creating 1 system out of the pipework of 2 systems, (L1-L2) must be 40 m or less.

L1: Distance between system 1's original outdoor unit and system 1's original farthest indoor unit.
 L2: Distance between system 2's original outdoor unit and system 2's original farthest indoor unit.
 $L1 \geq L2$

Outdoor	Pipe (Liquid)	Pipe (Gas)
PUHY-RP600YSJM-B	$\phi 19.05$	$\phi 34.93$
PUHY-RP650YSJM-B	$\phi 19.05$	$\phi 41.28$

Total down-stream Indoor capacity	Pipe (Liquid)	Pipe (Gas)
~ P80	$\phi 9.52$ [3/8"]	$\phi 15.88$ [5/8"]
P81 ~ P160	$\phi 12.7$ [1/2"]	$\phi 19.05$ [3/4"]
P161 ~ P330	$\phi 12.7$ [1/2"]	$\phi 25.4$ [1"]
P331 ~ P630	$\phi 15.88$ [5/8"]	$\phi 34.93$ [1-3/8"]
P631 ~	$\phi 19.05$ [3/4"]	$\phi 41.28$ [1-5/8"]

Indoor Unit size	Pipe (Liquid)	Pipe (Gas)
P20, P25, P32, P40	$\phi 6.35$ [1/4"]	$\phi 12.70$ [1/2"]
P50, P63, P71, P80	$\phi 9.52$ [3/8"]	$\phi 15.88$ [5/8"]
P140	$\phi 9.52$ [3/8"]	$\phi 19.05$ [3/4"]
P200	$\phi 12.7$ [1/2"]	$\phi 25.4$ [1"]
P250	$\phi 12.7$ [1/2"]	$\phi 28.58$ [1-1/8"]

Note 3. Indoor capacity is described as its model size.
 For example, PEFY-P32VMM-E, its capacity is P32.

Note 4. Total down-stream Indoor capacity is the summary of the model size of Indoors downstream.
 For example, PEFY-P25VMM-E + PEFY-P32VMM-E: Total Indoor capacity = P25 + P32 = P57

Note 5. Piping size determined by the Total down-stream indoor capacity is NOT necessary to be bigger than the up-stream one.
 i.e. $A \geq B$; $A \geq C \geq D$

3. Piping Design

3-1-4. PUHY-RP700-900YSJM-B

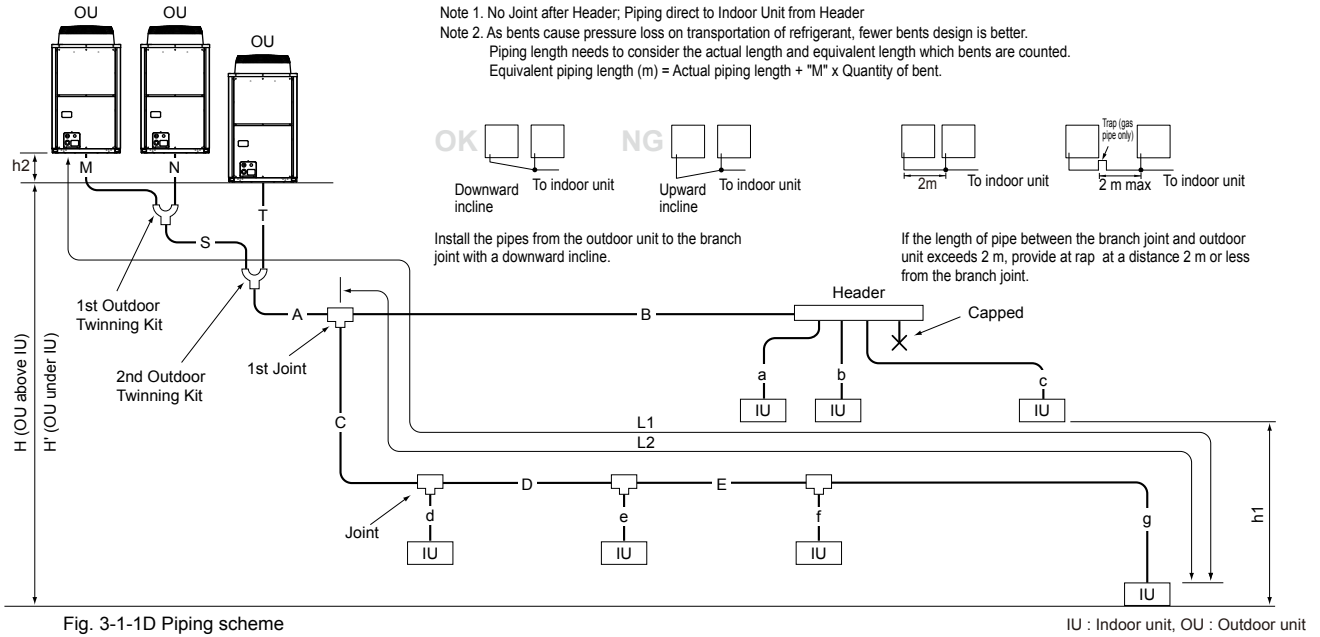

Table 3-1-4-1. Piping length (m)

Item	Piping in the figure	Max. length	Max. equivalent length
Total piping length	S+T+M+N+A+B+C+D+E+a+b+c+d+e+f+g	250 *1	
Distance between OU and OU	S+T+M+N	10	
Height between OU and OU	h2	0.1	
Farthest IU from OU (L1)	S(T)+A+C+D+E+g / S(T)+A+B+c	120	150
Farthest IU from the first Joint (L2)	C+D+E+g / B+c	40 *2	
Height between OU and IU (OU above IU)	H	50	
Height between OU and IU (OU under IU)	H'	40	
Height between IU and IU	h1	15	

OU: Outdoor Unit, IU: Indoor Unit

* 1 Do not exceed the amount of refrigerant to be charged written below.

$$\text{PUHY-RP700-900YSJM-B: } 0.39 \times L_0 + 0.29 \times L_1 + 0.2 \times L_2 + 0.12 \times L_3 + 0.06 \times L_4 + 0.024 \times L_5 < 25$$

L₀: Total length of ø22.2 liquid pipe (m)

L₁: Total length of ø19.05 liquid pipe (m)

L₂: Total length of ø15.88 liquid pipe (m)

L₃: Total length of ø12.7 liquid pipe (m)

L₄: Total length of ø9.52 liquid pipe (m)

L₅: Total length of ø6.35 liquid pipe (m)

* 2 When creating 1 system out of the pipework of 2 systems, (L1-L2) must be 40 m or less.

L1: Distance between system 1's original outdoor unit and system 1's original farthest indoor unit.

L2: Distance between system 2's original outdoor unit and system 2's original farthest indoor unit.

L1 ≥ L2

Table 3-1-4-2. Bent equivalent length "M"

Outdoor unit model	M (m/bent)
PUHY-RP700YSJM-B	0.70
PUHY-RP750YSJM-B	0.70
PUHY-RP800YSJM-B	0.70
PUHY-RP850YSJM-B	0.80
PUHY-RP900YSJM-B	0.80

Table 3-1-4-3. Piping "A" size selection rule (mm)

Outdoor	Pipe (Liquid)	Pipe (Gas)
PUHY-RP700YSJM-B	ø19.05	ø41.28
PUHY-RP750YSJM-B	ø19.05	ø41.28
PUHY-RP800YSJM-B	ø19.05	ø41.28
PUHY-RP850YSJM-B	ø19.05	ø41.28
PUHY-RP900YSJM-B	ø19.05	ø41.28

For Piping size "M", "N", "S", "T", please refer to specification of the Twinning kit CMY-RP200VBK at the Outdoor unit's external drawing.

Table 3-1-4-4. Piping "B", "C", "D", "E" size selection rule (mm [in.])

Total down-stream Indoor capacity	Pipe (Liquid)	Pipe (Gas)
~ P80	ø9.52 [3/8"]	ø15.88 [5/8"]
P81 ~ P160	ø12.7 [1/2"]	ø19.05 [3/4"]
P161 ~ P330	ø12.7 [1/2"]	ø25.4 [1"]
P331 ~ P630	ø15.88 [5/8"]	ø34.93 [1-3/8"]
P631 ~	ø19.05 [3/4"]	ø41.28 [1-5/8"]

Table 3-1-4-5. Piping "a", "b", "c", "d", "e", "f", "g" size selection rule (mm [in.])

Indoor Unit size	Pipe (Liquid)	Pipe (Gas)
P20, P25, P32, P40	ø6.35 [1/4"]	ø12.70 [1/2"]
P50, P63, P71, P80	ø9.52 [3/8"]	ø15.88 [5/8"]
P140	ø9.52 [3/8"]	ø19.05 [3/4"]
P200	ø12.7 [1/2"]	ø25.4 [1"]
P250	ø12.7 [1/2"]	ø28.58 [1-1/8"]

Note 3. Indoor capacity is described as its model size.
 For example, PEFY-P32VMM-E, its capacity is P32.

Note 4. Total down-stream Indoor capacity is the summary of the model size of Indoors downstream.
 For example, PEFY-P25VMM-E + PEFY-P32VMM-E: Total Indoor capacity = P25 + P32 = P57

Note 5. Piping size determined by the Total down-stream indoor capacity is NOT necessary to be bigger than the up-stream one.
 i.e. A >= B; A >= C >= D

3. Piping Design

3-1-5. Pipe diameter compatibility table

○	Standard
●	Usable (Unit performance will be affected.)
○	Usable (Vertical separation between OU and IU to be 20 m or less)
△	Usable (Piping length limitation will apply.)
△	Usable (Refrigerant charge amount limit will apply.)
×	Not use

(1) Main pipe

Outdoor model		200	250	300	350	400	450	500	550	600	650	700
Liquid	ø9.52	(45m or shorter)	(30m or shorter)	(25m or shorter)	×	×	×	×	×	×	×	×
	ø12.7	○	○	○	(65m or shorter)	(50m or shorter)	(40m or shorter)	(35m or shorter)	(30m or shorter)	×	×	×
	ø15.88	△	△	△	○	○	○	○	○	(70m or shorter)	(60m or shorter)	(55m or shorter)
	ø19.05	△	△	△	△	△	△	△	△	△	△	△
	ø22.2	△	△	△	△	△	△	△	△	△	△	△
Gas	ø15.88	×	×	×	×	×	×	×	×	×	×	×
	ø19.05	●	×	×	×	×	×	×	×	×	×	×
	ø22.2	●	●	●	×	×	×	×	×	×	×	×
	ø25.4	●	●	●	●	×	×	×	×	×	×	×
	ø28.58	○	○	○	●	●	●	●	●	●	●	×
	ø34.93	○	○	○	○	○	○	○	○	○	○	●
	ø41.28	×	×	×	○	○	○	○	○	○	○	○

Outdoor model		750	800	850	900
Liquid	ø9.52	×	×	×	×
	ø12.7	×	×	×	×
	ø15.88	(50m or shorter)	(45m or shorter)	(40m or shorter)	(35m or shorter)
	ø19.05	○	○	○	○
	ø22.2	△	△	△	△
Gas	ø15.88	×	×	×	×
	ø19.05	×	×	×	×
	ø22.2	×	×	×	×
	ø25.4	×	×	×	×
	ø28.58	×	×	×	×
	ø34.93	●	●	×	×
	ø41.28	○	○	○	○

(2) Indoor pipe

Indoor model		15	20	25	32	40	50	63	71	80	100	125
Liquid	ø6.35	○	○	○	○	○	(30m or shorter)	(20m or shorter)	×	×	×	×
	ø9.52	△	△	△	△	△	○	○	○	○	○	○
	ø12.7	△	△	△	△	△	△	△	△	△	△	△
	ø15.88	△	△	△	△	△	△	△	△	△	△	△
	ø19.05	○	○	○	○	○	○	○	○	○	○	○
Gas	ø12.7	×	×	×	×	×	●	×	×	×	×	×
	ø15.88	○	○	○	○	○	○	○	○	○	●	●
	ø19.05	×	×	×	×	×	○	○	○	○	○	○
	ø22.2	×	×	×	×	×	×	×	×	×	○	○
	ø25.4	×	×	×	×	×	×	×	×	×	×	×
	ø28.58	×	×	×	×	×	×	×	×	×	×	×

Indoor model		140	200	250
Liquid	ø6.35	×	×	×
	ø9.52	○	(25m or shorter)	(15m or shorter)
	ø12.7	△	○	○
	ø15.88	△	△	△
Gas	ø12.7	×	×	×
	ø15.88	●	×	×
	ø19.05	○	●	×
	ø22.2	○	●	●
	ø25.4	×	○	●
	ø28.58	×	○	○

(3) Joint pipe

Indoor model		-80	-140	-160	-200	-300	-330	-400	-630	-650	-800	801-
Liquid	ø9.52	○	(15m or shorter)	(15m or shorter)	(10m or shorter)	(10m or shorter)	×	×	×	×	×	×
	ø12.7	△	○	○	○	○	○	(30m or shorter)	×	×	×	×
	ø15.88	△	△	△	△	△	△	○	○	(30m or shorter)	×	×
	ø19.05	△	△	△	△	△	△	△	△	△	○	○
	ø22.2	△	△	△	△	△	△	△	△	△	△	△
Gas	ø15.88	○	●	×	×	×	×	×	×	×	×	×
	ø19.05	○	○	○	●	×	×	×	×	×	×	×
	ø22.2	×	○	○	●	●	×	×	×	×	×	×
	ø25.4	×	×	×	○	○	○	×	×	×	×	×
	ø28.58	×	×	×	○	○	○	●	●	●	●	×
	ø34.93	×	×	×	×	×	×	○	○	○	○	×
	ø41.28	×	×	×	×	×	×	○	○	○	○	○

Note

1) The △ in the table indicates that the existing piping system can be reused if the total amount of refrigerant charge in the existing system is less than the specified amount calculated by using the following formulas:

PUHY-RP200-250YJM-B : $0.39 \times L0 + 0.29 \times L1 + 0.2 \times L2 + 0.12 \times L3 + 0.06 \times L4 < 18$
 PUHY-RP300-900YJM-B : $0.39 \times L0 + 0.29 \times L1 + 0.2 \times L2 + 0.12 \times L3 + 0.06 \times L4 < 25$

- L0 : Total length of ø22.2 liquid pipe(m)
- L1 : Total length of ø19.05 liquid pipe(m)
- L2 : Total length of ø15.88 liquid pipe(m)
- L3 : Total length of ø12.7 liquid pipe(m)
- L4 : Total length of ø9.52 liquid pipe(m)
- L5 : Total length of ø6.35 liquid pipe(m)

3. Piping Design

3-1-6. Flow chart to check if the existing piping can be reused

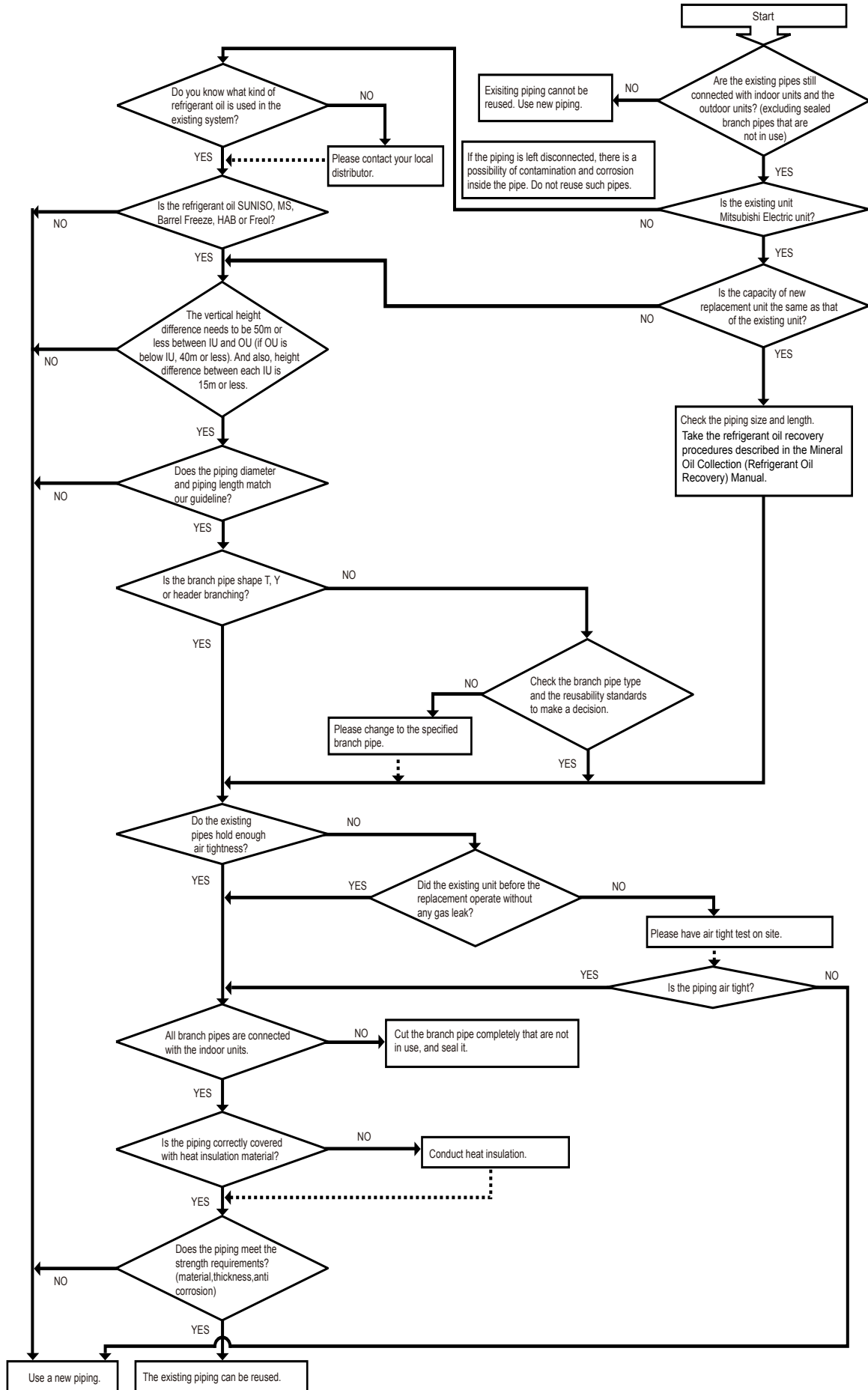

3. Piping Design

3-2. Refrigerant charging calculation

Sample connection (with 8 indoor units)

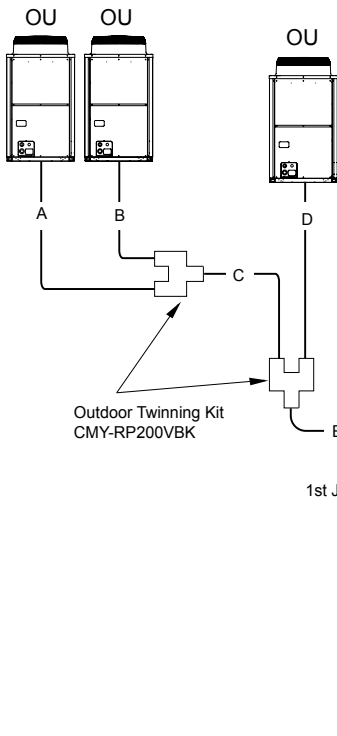

Note 1. No Joint after Header; Piping direct to Indoor Unit from Header
 Note 2. As bends cause pressure loss on transportation of refrigerant, fewer bends design is better.
 Piping length needs to consider the actual length and equivalent length which bends are counted.
 Equivalent piping length (m) = Actual piping length + "M" x Quantity of bent.

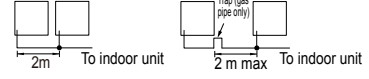
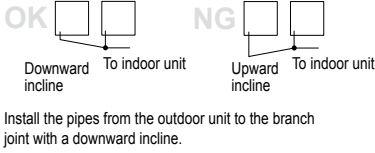

If the length of pipe between the branch joint and outdoor unit exceeds 2 m, provide a trap at a distance 2 m or less from the branch joint.

Amount of refrigerant to be charged

Refrigerant for extended pipes (field piping) is not factory-charged to the outdoor unit. Add an appropriate amount of refrigerant for each pipe on site.

Record the size of each liquid pipe and the amount of refrigerant that was charged on the outdoor unit for future reference.

Calculating the amount of refrigerant to be charged

- The amount of refrigerant to be charged is calculated with the size of the on-site-installed liquid pipes and their length.
- Calculate the amount of refrigerant to be charged according to the formula below.
- Round up the calculation result to the nearest 0.1 kg. (i.e., 16.08 kg = 16.1 kg)

<Amount of refrigerant to be charged>

Calculating the amount of refrigerant to be charged

Total length of $\phi 22.2$ liquid pipe x 0.39	+	Total length of $\phi 19.05$ liquid pipe x 0.29	+	Total length of $\phi 15.88$ liquid pipe x 0.2	+	Total length of $\phi 12.7$ liquid pipe x 0.12	+	Total length of $\phi 9.52$ liquid pipe x 0.06	+	Total length of $\phi 6.35$ liquid pipe x 0.024	+
(m) x 0.39 (kg/m)		(m) x 0.29 (kg/m)		(m) x 0.2 (kg/m)		(m) x 0.12 (kg/m)		(m) x 0.06 (kg/m)		(m) x 0.024 (kg/m)	

Total capacity of connected indoor units	Charged amount
~80	2.0 kg
81~160	2.5 kg
161~330	3.0 kg
331~390	3.5 kg
391~480	4.5 kg
481~630	5.0 kg
631~710	6.0 kg
711~800	8.0 kg
801~890	9.0 kg
891~1070	10.0 kg
1071~1170	12.0 kg

Amount of factory-charged refrigerant

Outdoor unit model	Charged amount
RP200	6.5kg
RP250	9.0kg
RP300	
RP350	

Sample calculation

Outdoor		Indoor	
A: $\phi 9.52$	3 m	1: P200	a: $\phi 12.7$ 15 m
B: $\phi 12.70$	2 m	2: P200	b: $\phi 12.7$ 15 m
C: $\phi 19.05$	2 m	3: P80	c: $\phi 9.52$ 5 m
D: $\phi 15.88$	1 m	4: P71	d: $\phi 9.52$ 5 m
E: $\phi 19.05$	10 m	5: P125	e: $\phi 9.52$ 5 m
F: $\phi 15.88$	10 m	6: P125	f: $\phi 9.52$ 5 m
G: $\phi 15.88$	5 m	7: P63	g: $\phi 9.52$ 5 m
I: $\phi 12.7$	5 m	8: P25	i: $\phi 6.35$ 5 m
J: $\phi 15.88$	20 m		
K: $\phi 12.7$	5 m		
M: $\phi 12.7$	5 m		

Total length for each pipe size: $\phi 19.05$ C + E = 12
 $\phi 15.88$ D + F + G + J = 1 + 10 + 5 + 20 = 36 m
 $\phi 12.70$ B + I + K + M + a + b = 2 + 5 + 5 + 5 + 15 + 15 = 47 m
 $\phi 9.52$ A + c + d + e + f + g = 3 + 5 + 5 + 5 + 5 + 5 = 23 m
 $\phi 6.35$ i = 5 m
 This yields the following result: = 0.29 x 12 + 0.2 x 36 + 0.12 x 47 + 0.06 x 23 + 0.024 x 5 + 9 = 26.82 kg = 26.9 kg

4. Outdoor Installation

4-1. Requirement on installation site

1. No direct thermal radiation to the unit.
2. No possibility of annoying the neighbors by the sound of the unit.
Valves and refrigerant flow on the outdoor unit may generate noise.
3. Avoid the sites where strong winds blow.
4. With strength to bear the weight of the unit.
5. Drain flow from the unit is cared at heating mode.
6. Enough space for installation and service as shown at 4-2.
7. Avoid the sites where acidic solutions or chemical sprays (sulfur series) are used frequently.
8. The unit should be secure from combustible gas, oil, steam, chemical gas like acidic solution, sulfur gas and so on.

4. Outdoor Installation

4-2. Spacing

In case of single installation

- Secure enough space around the unit as shown in the figure.

<A> : Top view

(A) : Front

(C) : Back

 : Side view

(B) : Unit height

(D) : Air outlet guide (Procured at the site)

<C> : When there is little space up to an obstruction

(1) If the distance is 300 mm [11-13/16 in.] or more between the rear side and the wall

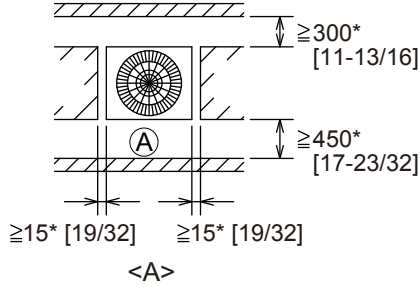

(2) If the distance is 100 mm [3-15/16 in.] or more between the rear side and the wall

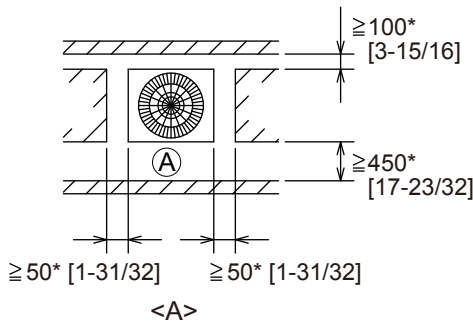

(3) If the wall height (H) of the front, rear or side exceeds the wall height restriction

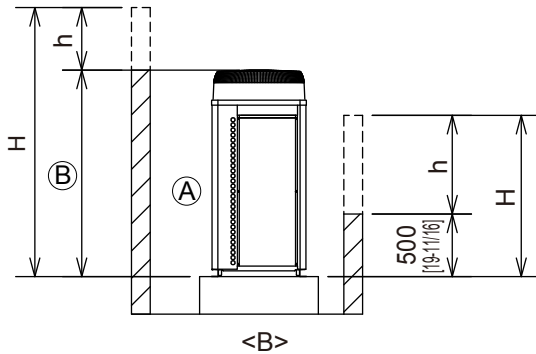

- When the height of the walls on the front, back or on the sides <H> exceeds the wall height limit as defined below, add the height that exceeds the height limit <h> to the figures that are marked with an asterisk.

<Wall height limit> Front: Up to the unit height

Back: Up to 500mm [19-11/16 in.] from the unit bottom

Side: Up to the unit height

If the unit cannot be kept clear of the wall, please change the direction of the air outlet of the unit to blow against the wall to avoid air short cycle.

(4) If there are obstacles at the upper part of the unit

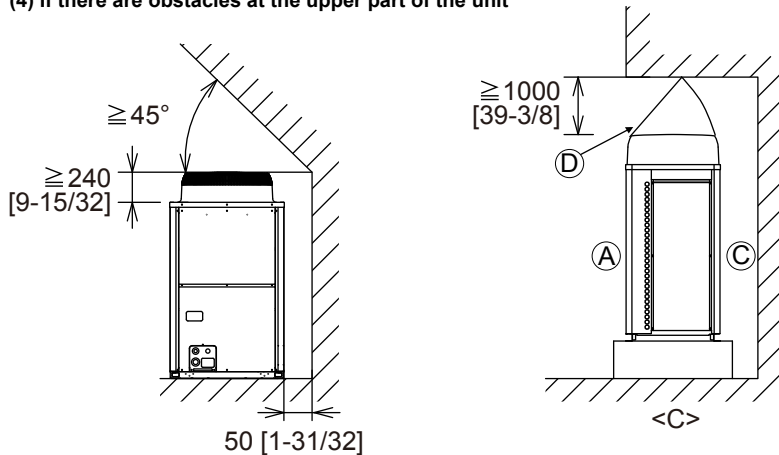

(Unit : mm [in.])

4. Outdoor Installation

In case of collective installation and continuous installation

(A) : Front (C) : Wall height (H)

(B) : Must be open

- When multiple units are installed adjacent to each other, secure enough space to allow for air circulation and passageways between groups of units as shown in the figures.
- At least two sides must be left open.
- As with the single installation, add the height that exceeds the height limit <h> to the figures that are marked with an asterisk.
- If there is a wall at both the front and the rear of the unit, install up to six units consecutively in the side direction and provide a space of 1000mm or more as inlet space/passage space for each six units.

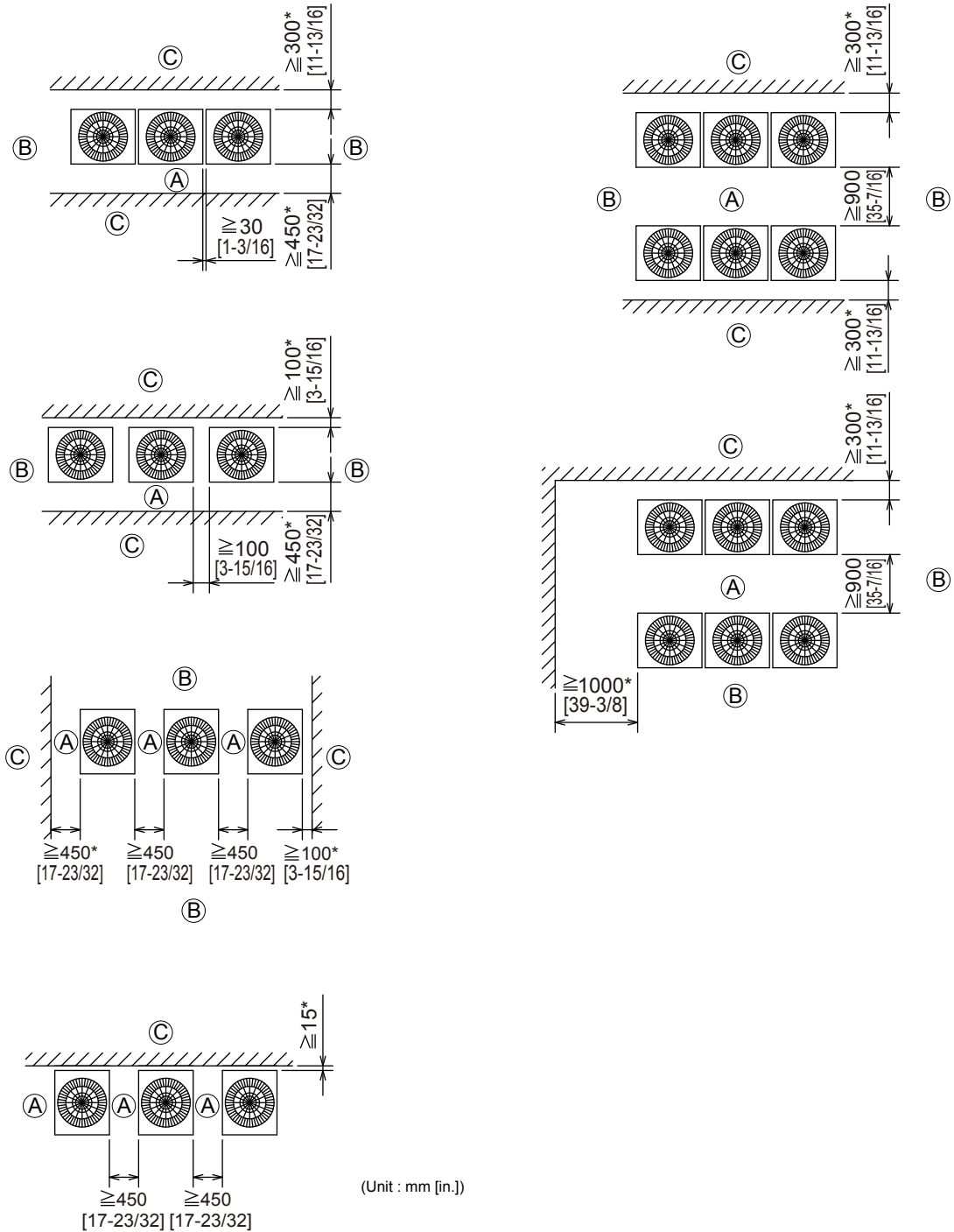

(Unit : mm [in.])

4. Outdoor Installation

4-3. Piping direction

4-3-1. Lifting method

- When lifting the unit with ropes, run the ropes under the unit and use the lifting hole.
- Support the unit at four points with two ropes, and avoid giving mechanical shock.
- Suspension rope angle must be 40° or less, so as to avoid compressing fan guard.
- Use two ropes, each at least 8m [26 ft.] in length
- Use ropes strong enough to support the weight of the unit.
- Always suspend the unit from four corners. (It is dangerous to suspend a unit from two corners and must not be attempted.)
- Use protective pads to keep the ropes from scratching the panels on the unit.

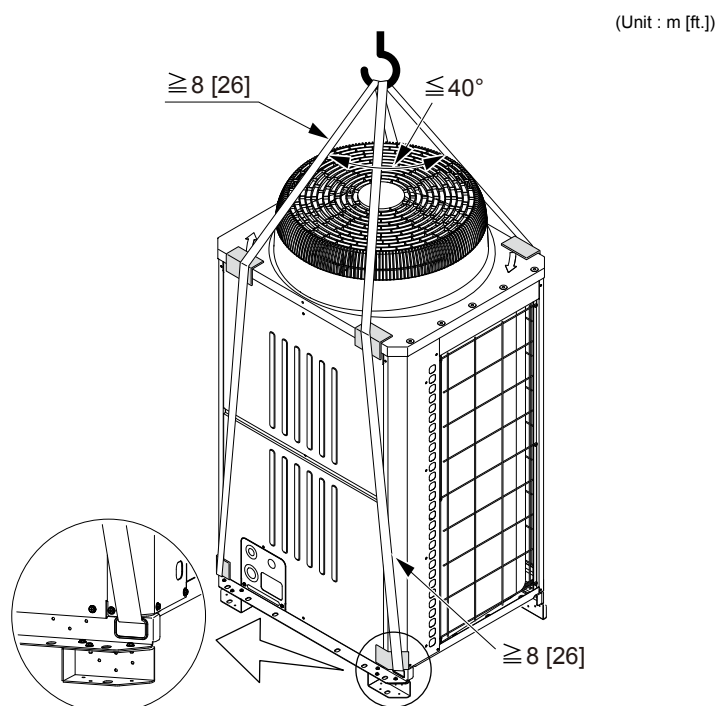

CAUTION

Exercise caution when transporting products.

- Products weighing more than 20 kg [45 LBS] should not be carried alone.
- Do not carry the product by the PP bands.
- To avoid the risk of injury, do not touch the heat exchanger fins.
- Plastic bags may pose a risk of choking hazard to children. Tear plastic bags into pieces before disposing of them.
- When lifting and transporting outdoor units with ropes, run the ropes through lifting hole at the unit base. Securely fix the unit so that the ropes will not slide off, and always lift the unit at four points to prevent the unit from falling.

4. Outdoor Installation

4-3-2. Installation

- Secure the unit with anchor bolts as shown in the figure below so that the unit will not topple over with strong wind or during an earthquake.
- Install the unit on a durable base made of such materials as concrete or angle steel.
- Take appropriate anti-vibration measures (e.g., vibration damper pad, vibration isolation base) to keep vibrations and noise from being transmitted from the unit through walls and floors.
- When using a rubber cushion, install it so that the cushion covers the entire width of the unit leg.
- Install the unit in such a way that the corner of the angle bracket at the base of the unit shown in the figure below is securely supported.
- Install the anchor bolt in such a way that the top end of the anchor bolt do not stick out more than 30 mm [1-3/16 in.].
- This unit is not designed to be anchored with post-installation-type anchor bolts, although by adding fixing brackets anchoring with such type of anchor bolts becomes possible.

- (A): M10 anchor bolt procured at the site.
 - (B): Corner is not seated.
 - (C): Fixing bracket for hole-in anchor bolt (3 locations to fix with screws).
 - (D): Detachable leg
- <Without detachable leg>

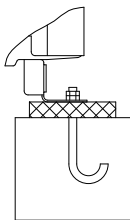
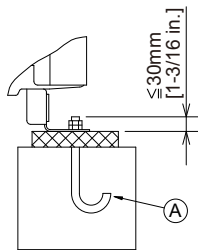

Install the unit in such a way that the corner of the angle bracket at the base of the unit shown in the figure is securely supported. The brackets may bend if they are not securely supported.

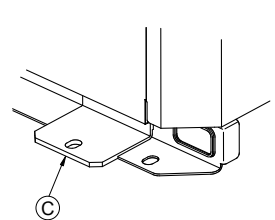
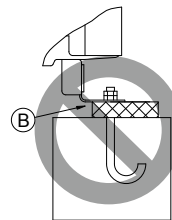

! WARNING
Properly install the unit on a surface that can withstand the weight of the unit. Unit installed on an unstable surface may fall and cause injury.

! WARNING
Take appropriate safety measures against strong winds and earthquakes to prevent the unit from falling.

<With detachable leg>

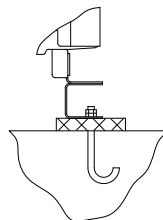
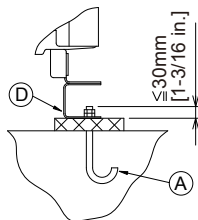

Install the unit in such a way that the corner of the angle bracket at the base of the unit shown in the figure is securely supported. The brackets may bend if they are not securely supported.

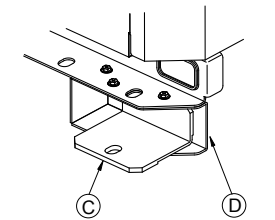
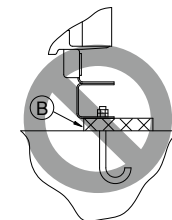

Take into consideration the durability of the base, water drainage route (Drain water is discharged from outdoor units during operation.), piping route, and wiring route when performing foundation work.

4-3-3. Anchor bolt positions

• Individual installation

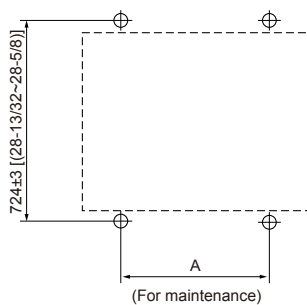

• Collective installation

(Unit : mm [in.])

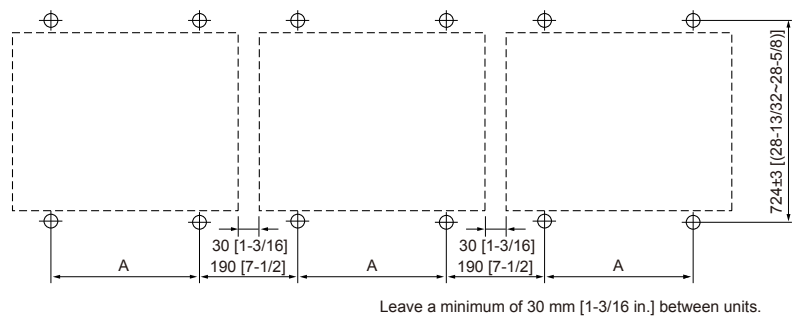

PUHY	RP200-RP350
A	760±2 [29-15/16(29-27/32~30)]

4. Outdoor Installation

4-3-4. Installation

When the pipes and/or cables are routed at the bottom of the unit, make sure that the through hole at the base of the unit does not get blocked with the installation base.

When the pipes are routed at the bottom of the unit, the base should be at least 100 mm [3-15/16 in.] in height.

· RP200-RP350

(Unit : mm [in.])

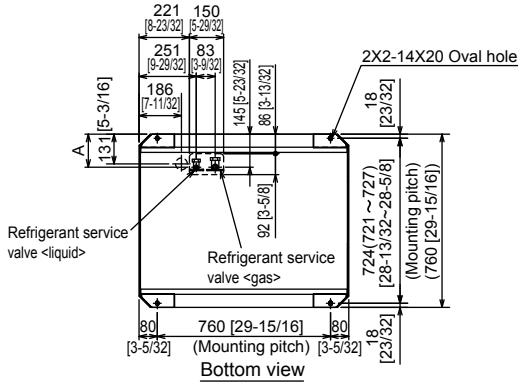

Model	A
PUHY-RP200YJM-B(-BS)	145 [5-23/32]
PUHY-RP250YJM-B(-BS)	
PUHY-RP300YJM-B(-BS)	
PUHY-RP350YJM-B(-BS)	150 [5-29/32]

Installation base perpendicular to the unit's front panel

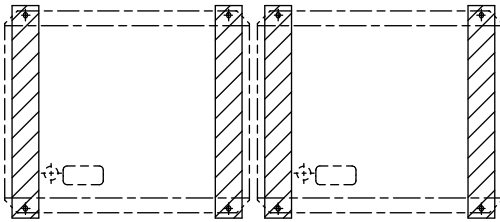

4-3-5. Refrigerant pipe routing

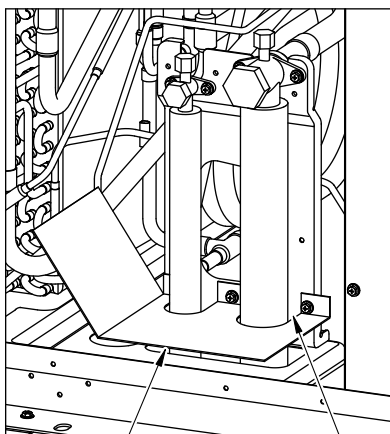

Filler plate
(not supplied)

Fill the gap at the site

The gaps around the edges of through holes for pipes and wires on the unit allow water or mice to enter the unit and damage its parts. Close these gaps with filler plates.

This unit allows two types of pipe routing:

- Bottom piping
- Front piping

CAUTION

To prevent small animals, water, and snow from entering the unit and damage its parts, close the gap around the edges of through holes for pipes and wires with filler plates.

4. Outdoor Installation

4-3-6. Twinning on the outdoor unit side

- The tilt angle of the twinning pipe
The tilt angle of the twinning pipe must be within $\pm 15^\circ$ with the horizontal plane.
Tilting the twinning pipe more than specified will cause damage to the unit.
- The length of the straight part of the pipe before the branching
For the twinning kit, always use the accessory piping parts.
The length of the straight part of pipe connected in front of the twinning pipe must be 500 mm [19 in.] or longer.
(Connect the field piping so that the length of the straight part of pipe connected in front of the twinning pipe can be 500 mm [19 in.] or longer.)
If the length is less than 500 mm [19 in.], it will cause damage to the unit.
- The piping connection
When connecting the twinning kit to the outdoor unit, note the following:
If the length of piping from the twinning kit to the outdoor unit is more than 2 m [6 ft.], install a trap within 2 m [6 ft.] from the outdoor unit. The height of the trap must be 200 mm [7 in.] or higher.

Note: See the following drawing for the fitting position of the twinning pipe.

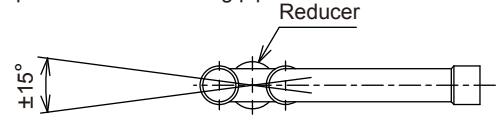

The tilt angle of the reducer should be within $\pm 15^\circ$ with the horizontal plane.

<2 m [6 ft.] or less>

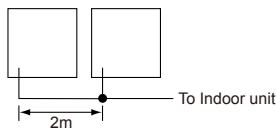

<More than 2 m [6 ft.]>

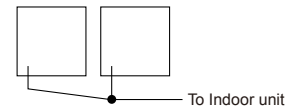
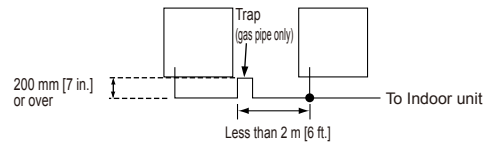

When installing the twinning kit in a higher position than the outdoor unit base, make sure that the twinning kit is installed in a position lower than 200 mm [7 in.] from the outdoor unit base.

<PUHY-RP500YSJM-B>

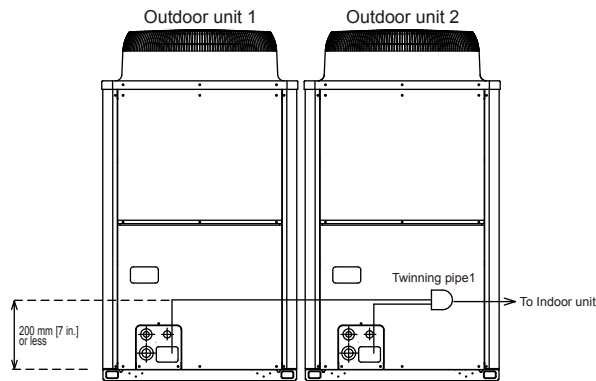

<PUHY-RP900YSJM-B>

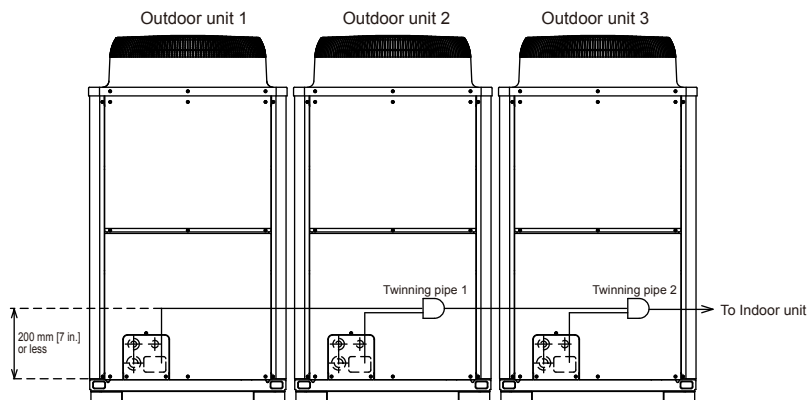

4. Outdoor Installation

4-3-7. Twinning on the outdoor unit side

See the following drawing for connecting the pipes between the outdoor units.

<PUHY-RP500YSJM-B>

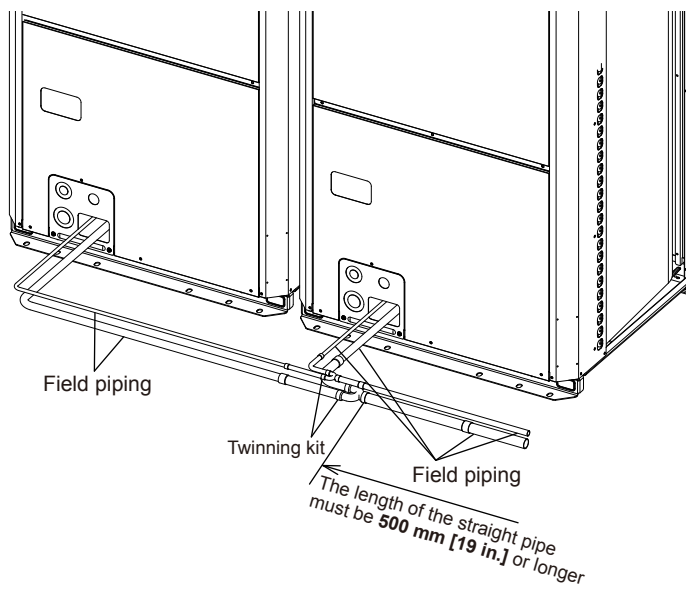

<PUHY-RP900YSJM-B>

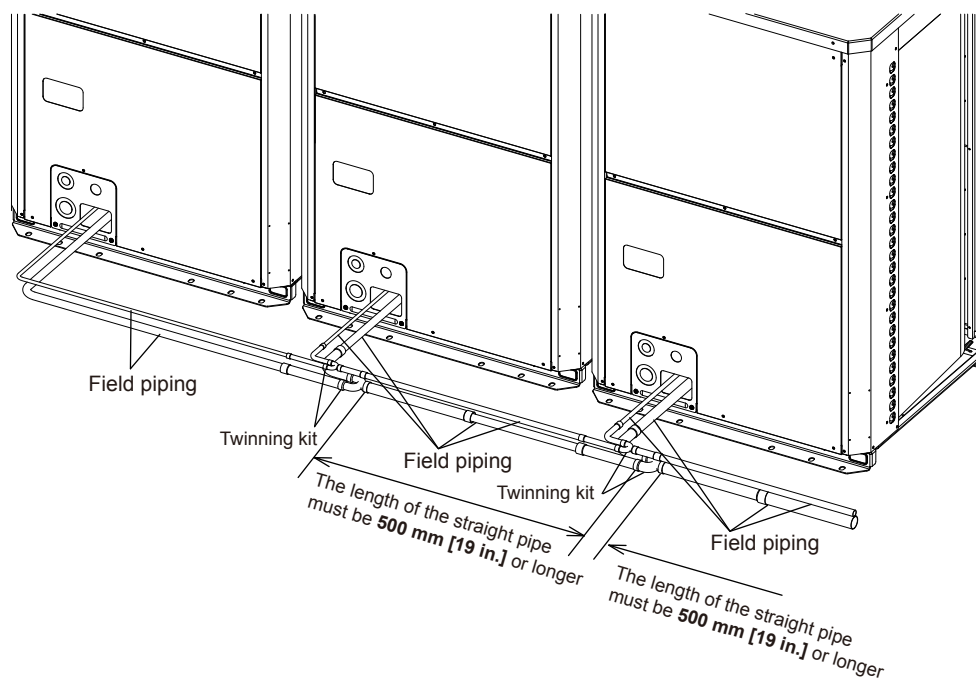

CAUTION

The length of the straight pipe must be 500mm[19 in.] or longer.
If not, it may cause improper operation.

4. Outdoor Installation

4-4. Weather countermeasure

- Snow hood

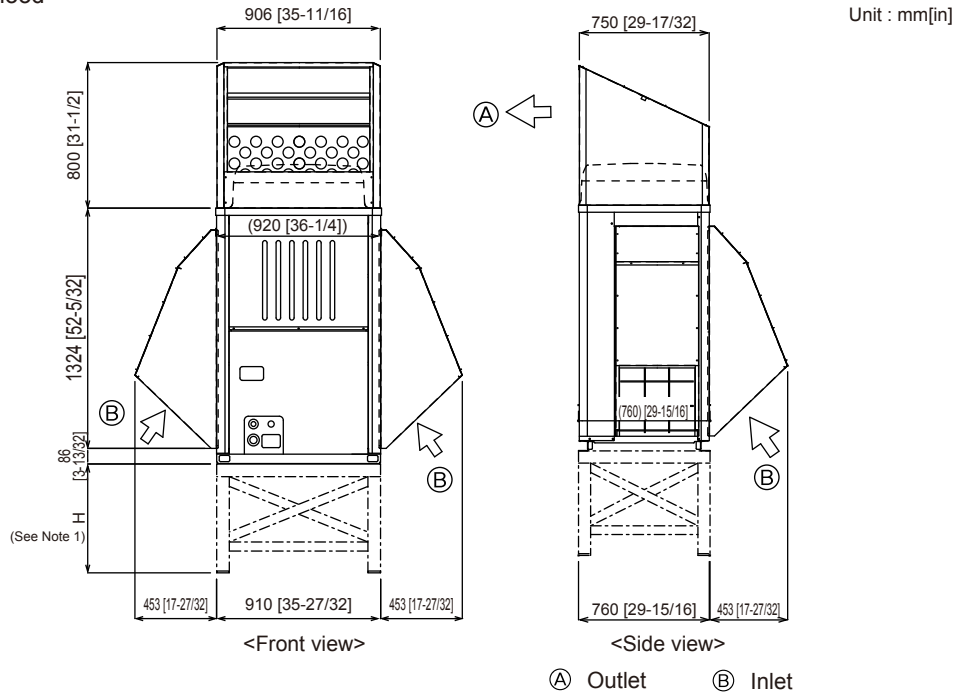

Note:

1. Height of frame base for snow damage prevention (H) shall be twice as high as expected snowfall. Width of frame base shall not exceed that of the unit. The frame base shall be made of angle steel, etc., and designed so that snow and wind slip through the structure. (If frame base is too wide, snow will be accumulated on it.)
2. Install unit so that wind will not directly lash against openings of inlet and outlet ducts.
3. Build frame base at customer referring to this figure.
Material: Galvanized steel plate 1.2T [1/16 in T]
Painting: Overall painting with polyester powder
Color: Munsell 5Y8/1 (same as that of unit)
4. When the unit is used in a cold region and the heating operation is continuously performed for a long time when the outside air temperature is below freezing, install a heater to the unit base or take other appropriate measures to prevent water from freezing on the base.

Countermeasure to wind

Referring to the figure shown below, take appropriate measures which will suit the actual situation of the place for installation.

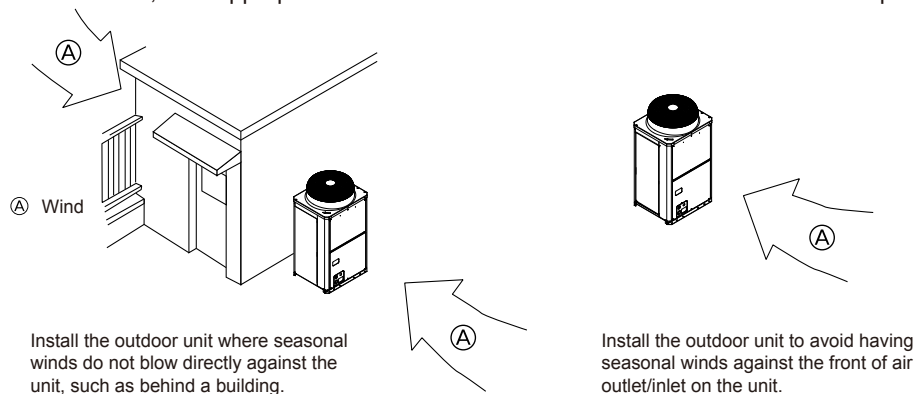

4. Outdoor Installation

4-5. Caution on selecting outdoor units

Consult your dealer when the following issues on Y system are the key concern.

- Warm air may flow out from the indoor unit during heating Thermo-OFF.
- Refrigerant flow sound may occur in the rooms with low background noise such as hotel rooms, hospital rooms, bedrooms, or conference rooms.

To avoid the above issues on Y system, changing board settings on the indoor and outdoor units is required.

Ask AC&R Works for details.

5. Caution for refrigerant leakage

The installer and/or air conditioning system specialist shall secure safety against refrigerant leakage according to local regulations or standards. The following standard may be applicable if no local regulation or standard is available.

5-1. Refrigerant property

R410A refrigerant is harmless and incombustible. The R410A is heavier than the indoor air in density. Leakage of the refrigerant in a room has possibility to lead to a hypoxia situation. Therefore, the Critical concentration specified below shall not be exceeded even if the leakage happens.

• Critical concentration

Critical concentration hereby is the refrigerant concentration in which no human body would be hurt if immediate measures can be taken when refrigerant leakage happens.

Critical concentration of R410A: 0.30kg/m³

(The weight of refrigeration gas per 1 m³ air conditioning space.);

* The Critical concentration is subject to ISO5149, EN378-1.

For the CITY MULTI system, the concentration of refrigerant leaked should not have a chance to exceed the Critical concentration in any situation.

5-2. Confirm the Critical concentration and take countermeasure

The maximum refrigerant leakage concentration (Rmax) is defined as the result of the possible maximum refrigerant weight (Wmax) leaked into a room divided by its room capacity (V). It is referable to Fig.5-1. The refrigerant of Outdoor unit here includes its original charge and additional charge at the site.

The additional charge is calculated according to "3-2 .Refrigerant charging calculation" and shall not be over charged at the site.

Procedure 5-2-1~3 tells how to confirm maximum refrigerant leakage concentration (Rmax) and how to take countermeasures against a possible leakage.

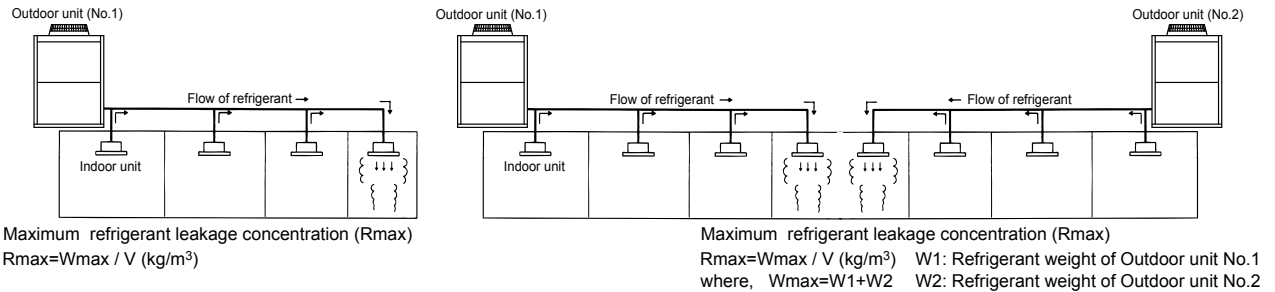

Fig. 5-1 The maximum refrigerant leakage concentration

5-2-1. Find the room capacity (V),

If a room having total opening area more than 0.15% of the floor area at a low position with another room/space, the two rooms/space are considered as one. The total space shall be added up.

5-2-2. Find the possible maximum leakage (Wmax) in the room. If a room has Indoor unit(s) from more than 1 Outdoor unit, add up the refrigerant of the Outdoor units.

5-2-3. Divide (Wmax) by (V) to get the maximum refrigerant leakage concentration (Rmax).

5-2-4. Find if there is any room in which the maximum refrigerant leakage concentration (Rmax) is over 0.30kg/m³.

If no, then the CITY MULTI is safe against refrigerant leakage.

If yes, following countermeasure is recommended to do at site.

Countermeasure 1: Let-out (making V bigger)

Design an opening of more than 0.15% of the floor area at a low position of the wall to let out the refrigerant whenever leaked.

e.g. make the upper and lower seams of door big enough.

Countermeasure 2: Smaller total charge (making Wmax smaller)

e.g. Avoid connecting more than 1 Outdoor unit to one room.

e.g. Using smaller model size but more Outdoor units.

e.g. Shorten the refrigerant piping as much as possible.

Countermeasure 3: Fresh air in from the ceiling (Ventilation)

As the density of the refrigerant is bigger than that of the air. Fresh air supply from the ceiling is better than air exhausting from the ceiling.

Fresh air supply solution refers to Fig.5-2~4.

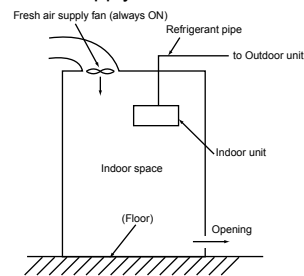

Fig.5-2. Fresh air supply always ON

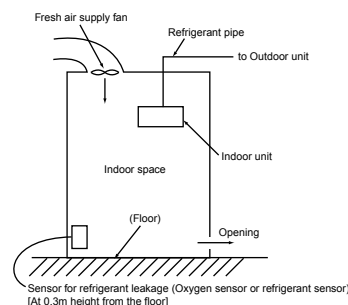

Fig.5-3. Fresh air supply upon sensor action

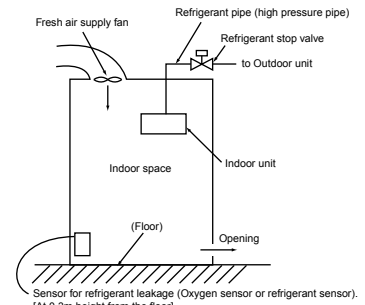

Fig.5-4. Fresh air supply and refrigerant shut-off upon sensor action

Note 1. Countermeasure 3 should be done in a proper way in which the fresh air supply shall be on whenever the leakage happens.

Note 2. In principle, MITSUBISHI ELECTRIC requires proper piping design, installation and air-tight testing after installation to avoid leakage happening.

In the area should earthquake happen, anti-vibration measures should be fully considered.

The piping should consider the extension due to the temperature variation.

SYSTEM DESIGN R2 SERIES

1. Electrical work.....	242
1-1.General cautions	242
1-2.Power supply for Indoor unit and Outdoor unit	243
1-3.Power cable specifications	247
1-4.Power supply examples.....	248
2. M-NET control.....	249
2-1.Transmission cable length limitation.....	249
2-2.Transmission cable specifications	250
2-3.System configuration restrictions.....	255
2-4.Address setting.....	258
3. Piping Design.....	271
3-1.Piping Design	271
3-2.Refrigerant charging calculation	275
4. Outdoor Installation.....	276
4-1.Requirement on installation site	276
4-2.Spacing.....	277
4-3.Piping direction	279
4-4.Weather countermeasure	282
5. Caution for refrigerant leakage	283
5-1.Refrigerant property.....	283
5-2.Confirm the Critical concentration and take countermeasure.....	283

1. Electrical work

1-1. General cautions

- ① Follow ordinance of your governmental organization for technical standard related to electrical equipment, wiring regulations, and guidance of each electric power company.
- ② Wiring for control (hereinafter referred to as transmission cable) shall be (50mm[1-5/8in.] or more) apart from power source wiring so that it is not influenced by electric noise from power source wiring. (Do not insert transmission cable and power source wire in the same conduit.)
- ③ Be sure to provide designated grounding work to outdoor unit.
- ④ Give some allowance to wiring for electrical part box of indoor and outdoor units, because the box is sometimes removed at the time of service work.
- ⑤ Never connect 380~415V(220~240V) power source to terminal block of transmission cable. If connected, electrical parts will be burnt out.
- ⑥ Use 2-core shield cable for transmission cable. If transmission cables of different systems are wired with the same multiple-core cable, the resultant poor transmitting and receiving will cause erroneous operations.

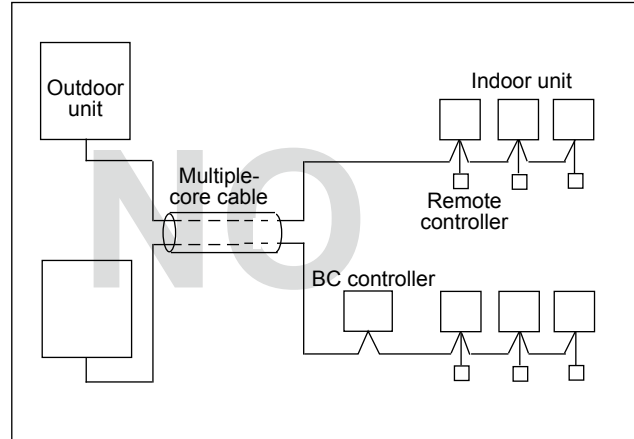
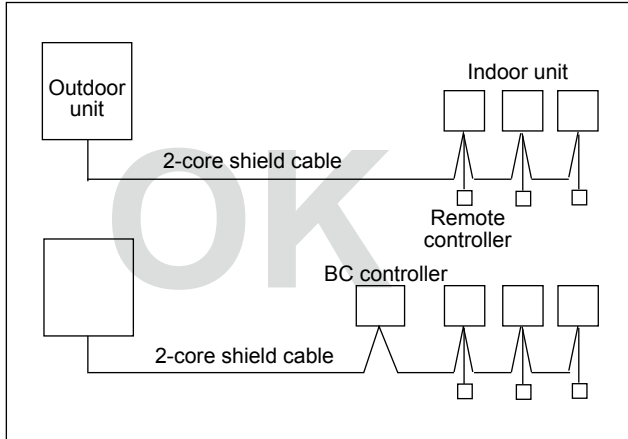

1. Electrical work

1-2. Power supply for Indoor unit and Outdoor unit

1-2-1. Electrical characteristics of Indoor unit

Symbols: MCA : Max.Circuit Amps (=1.25xFLA) FLA : Full Load Amps

IFM :Indoor Fan Motor

Output : Fan motor rated output

PMFY-P-VBM-E	Power supply			IFM	
	Volts / Hz	Range +-10%	MCA(A)	Output(kW)	FLA(A)
PMFY-P20VBM-E	220-240V / 50Hz 220V / 60Hz	Max.: 264V Min.: 198V	0.25	0.028	0.20
PMFY-P25VBM-E			0.26	0.028	0.21
PMFY-P32VBM-E			0.26	0.028	0.21
PMFY-P40VBM-E			0.33	0.028	0.26

PLFY-P-VCM-E	Power supply			IFM	
	Volts / Hz	Range +-10%	MCA(A)	Output(kW)	FLA(A)
PLFY-P20VCM-E	220-240V / 50Hz	Max.: 264V Min.: 198V	0.29	0.011	0.23
PLFY-P25VCM-E			0.29	0.015	0.23
PLFY-P32VCM-E			0.35	0.020	0.28
PLFY-P40VCM-E			0.35	0.020	0.28

PLFY-P-VBM-E	Power supply			IFM	
	Volts / Hz	Range +-10%	MCA(A)	Output(kW)	FLA(A)
PLFY-P32VBM-E	220-240V / 50Hz 220V / 60Hz	Max.: 264V Min.: 198V	0.28	0.050	0.22
PLFY-P40VBM-E			0.36	0.050	0.29
PLFY-P50VBM-E			0.36	0.050	0.29
PLFY-P63VBM-E			0.45	0.050	0.36
PLFY-P80VBM-E			0.64	0.050	0.51
PLFY-P100VBM-E			1.25	0.120	1.00
PLFY-P125VBM-E			1.34	0.120	1.07

PLFY-P-VLMD-E	Power supply			IFM	
	Volts / Hz	Range +-10%	MCA(A) (50 / 60Hz)	Output(kW)	FLA(A) (50 / 60Hz)
PLFY-P20VLMD-E	220-240V / 50Hz 220-230V / 60Hz	Max.: 264V Min.: 198V	0.45 / 0.46	0.015	0.36 / 0.37
PLFY-P25VLMD-E			0.45 / 0.46	0.015	0.36 / 0.37
PLFY-P32VLMD-E			0.45 / 0.46	0.015	0.36 / 0.37
PLFY-P40VLMD-E			0.50 / 0.53	0.015	0.40 / 0.42
PLFY-P50VLMD-E			0.51 / 0.54	0.020	0.41 / 0.43
PLFY-P63VLMD-E			0.61 / 0.64	0.020	0.49 / 0.51
PLFY-P80VLMD-E			0.90 / 0.93	0.020	0.72 / 0.74
PLFY-P100VLMD-E			0.94 / 1.10	0.030	0.75 / 0.88
PLFY-P125VLMD-E			1.69 / 1.69	0.078x2	1.35 / 1.35

PEFY-P-VMR-E-L/R	Power supply			IFM	
	Volts / Hz	Range +-10%	MCA(A) (50 / 60Hz)	Output(kW)	FLA(A) (50 / 60Hz)
PEFY-P20VMR-E-L/R	220-240V / 50Hz 220-230V / 60Hz	Max.: 264V Min.: 198V	0.37 / 0.37	0.018	0.29 / 0.29
PEFY-P25VMR-E-L/R			0.37 / 0.37	0.018	0.29 / 0.29
PEFY-P32VMR-E-L/R			0.43 / 0.48	0.023	0.34 / 0.38

PEFY-P-VMS1-E	Power supply			IFM	
	Volts / Hz	Range +-10%	MCA(A) (50 / 60Hz)	Output(kW)	FLA(A) (50 / 60Hz)
PEFY-P15VMS1-E	220-240V / 50Hz 220-240V / 60Hz	Max.: 264V Min.: 198V	0.63 / 0.63	0.096	0.50 / 0.50
PEFY-P20VMS1-E			0.70 / 0.70	0.096	0.56 / 0.56
PEFY-P25VMS1-E			0.75 / 0.75	0.096	0.60 / 0.60
PEFY-P32VMS1-E			0.75 / 0.75	0.096	0.60 / 0.60
PEFY-P40VMS1-E			0.83 / 0.82	0.096	0.66 / 0.65
PEFY-P50VMS1-E			1.02 / 1.00	0.096	0.81 / 0.80
PEFY-P63VMS1-E			1.08 / 1.07	0.096	0.86 / 0.85

1. Electrical work

Symbols: MCA : Max.Circuit Amps (=1.25xFLA) FLA : Full Load Amps
 IFM :Indoor Fan Motor Output : Fan motor rated output

PEFY-P-VMS1L-E	Power supply			IFM	
	Volts / Hz	Range +-10%	MCA(A) (50 / 60Hz)	Output(kW)	FLA(A) (50 / 60Hz)
PEFY-P15VMS1L-E	220-240V / 50Hz 220-240V / 60Hz	Max.: 264V Min.: 198V	0.46 / 0.46	0.096	0.37 / 0.37
PEFY-P20VMS1L-E			0.54 / 0.54	0.096	0.43 / 0.43
PEFY-P25VMS1L-E			0.59 / 0.59	0.096	0.47 / 0.47
PEFY-P32VMS1L-E			0.59 / 0.59	0.096	0.47 / 0.47
PEFY-P40VMS1L-E			0.68 / 0.68	0.096	0.54 / 0.54
PEFY-P50VMS1L-E			0.84 / 0.84	0.096	0.67 / 0.67
PEFY-P63VMS1L-E			0.91 / 0.91	0.096	0.73 / 0.73

PEFY-P-VMH-E	Power supply			IFM	
	Volts / Hz	Range +-10%	MCA(A) (50 / 60Hz)	Output(kW)	FLA(A) (50 / 60Hz)
PEFY-P40VMH-E	220-240V / 50Hz 220-240V / 60Hz	Max.: 264V Min.: 198V	1.21 / 1.61	0.08	0.97 / 1.29
PEFY-P50VMH-E			1.21 / 1.61	0.08	0.97 / 1.29
PEFY-P63VMH-E			1.49 / 1.95	0.12	1.19 / 1.56
PEFY-P71VMH-E			1.58 / 2.18	0.14	1.26 / 1.74
PEFY-P80VMH-E			1.85 / 2.40	0.18	1.48 / 1.92
PEFY-P100VMH-E			3.03 / 3.93	0.26	2.42 / 3.14
PEFY-P125VMH-E			3.03 / 3.93	0.26	2.42 / 3.14
PEFY-P140VMH-E			3.10 / 3.98	0.26	2.48 / 3.18
PEFY-P200VMH-E	380-415V / 50Hz	Max.: 456V	2.03 / 2.33	0.76	1.62 / 1.86
PEFY-P250VMH-E	380-415V / 60Hz	Min.: 342V	2.50 / 2.88	1.08	2.00 / 2.30

PEFY-P-VMA-E	Power supply			IFM	
	Volts / Hz	Range +-10%	MCA(A)	Output(kW)	FLA(A)
PEFY-P20VMA-E	220-240V / 50Hz 220-240V / 60Hz	Max.: 264V Min.: 198V	1.03	0.085	0.82
PEFY-P25VMA-E			1.03	0.085	0.82
PEFY-P32VMA-E			1.18	0.085	0.95
PEFY-P40VMA-E			1.43	0.085	1.14
PEFY-P50VMA-E			1.54	0.085	1.23
PEFY-P63VMA-E			2.22	0.121	1.78
PEFY-P71VMA-E			2.46	0.121	1.97
PEFY-P80VMA-E			2.47	0.121	1.98
PEFY-P100VMA-E			3.30	0.244	2.64
PEFY-P125VMA-E			3.39	0.244	2.71
PEFY-P140VMA-E			3.29	0.244	2.63

PEFY-P-VMAL-E	Power supply			IFM	
	Volts / Hz	Range +-10%	MCA(A)	Output(kW)	FLA(A)
PEFY-P20VMAL-E	220-240V / 50Hz 220-240V / 60Hz	Max.: 264V Min.: 198V	0.92	0.085	0.74
PEFY-P25VMAL-E			0.92	0.085	0.74
PEFY-P32VMAL-E			1.07	0.085	0.86
PEFY-P40VMAL-E			1.32	0.085	1.06
PEFY-P50VMAL-E			1.40	0.085	1.12
PEFY-P63VMAL-E			2.08	0.121	1.67
PEFY-P71VMAL-E			2.32	0.121	1.86
PEFY-P80VMAL-E			2.36	0.121	1.89
PEFY-P100VMAL-E			3.19	0.244	2.55
PEFY-P125VMAL-E			3.27	0.244	2.62
PEFY-P140VMAL-E			3.17	0.244	2.53

PEFY-P-VMH-E-F	Power supply			IFM	
	Volts / Hz	Range +-10%	MCA(A) (50 / 60Hz)	Output(kW)	FLA(A) (50 / 60Hz)
PEFY-P80VMH-E-F	220-240V / 50Hz	Max.: 264V	0.92 / 1.15	0.09	0.73 / 0.92
PEFY-P140VMH-E-F	208-230V / 60Hz	Min.: 187V	1.58 / 1.84	0.14	1.26 / 1.47
PEFY-P200VMH-E-F	380-415V / 50Hz	Max.: 456V	0.73 / 0.93	0.20	0.58 / 0.74
PEFY-P250VMH-E-F	380-415V / 60Hz	Min.: 342V	0.85 / 1.08	0.23	0.68 / 0.86

1. Electrical work

Symbols: MCA : Max.Circuit Amps (=1.25xFLA) FLA : Full Load Amps
IFM :Indoor Fan Motor Output : Fan motor rated output

PKFY-P-VBM-E	Power supply			IFM	
	Volts / Hz	Range +-10%	MCA(A)	Output(kW)	FLA(A)
PKFY-P15VBM-E	220-240V / 50Hz 220V / 60Hz	Max.: 264V Min.: 198V	0.25	0.017	0.20
PKFY-P20VBM-E			0.25	0.017	0.20
PKFY-P25VBM-E			0.25	0.017	0.20

PKFY-P-VHM-E	Power supply			IFM	
	Volts / Hz	Range +-10%	MCA(A)	Output(kW)	FLA(A)
PKFY-P32VHM-E	220-240V / 50Hz 220V / 60Hz	Max.: 264V Min.: 198V	0.38	0.030	0.30
PKFY-P40VHM-E			0.38	0.030	0.30
PKFY-P50VHM-E			0.38	0.030	0.30

PKFY-P-VKM-E	Power supply			IFM	
	Volts / Hz	Range +-10%	MCA(A)	Output(kW)	FLA(A)
PKFY-P63VKM-E	220-240V / 50Hz 220V / 60Hz	Max.: 264V Min.: 198V	0.36	0.056	0.29
PKFY-P100VKM-E			0.63	0.056	0.50

PCFY-P-VKM-E	Power supply			IFM	
	Volts / Hz	Range +-10%	MCA(A)	Output(kW)	FLA(A)
PCFY-P40VKM-E	220-240V / 50Hz 220V / 60Hz	Max.: 264V Min.: 198V	0.35	0.090	0.28
PCFY-P63VKM-E			0.41	0.095	0.33
PCFY-P100VKM-E			0.81	0.160	0.65
PCFY-P125VKM-E			0.95	0.160	0.76

PFFY-P-VKM-E	Power supply			IFM	
	Volts / Hz	Range +-10%	MCA(A)	Output(kW)	FLA(A)
PFFY-P20VKM-E	220-240V / 50Hz	Max.: 264V Min.: 198V	0.25	0.03x2	0.20
PFFY-P25VKM-E			0.25	0.03x2	0.20
PFFY-P32VKM-E			0.25	0.03x2	0.20
PFFY-P40VKM-E			0.30	0.03x2	0.24

PFFY-P-VLEM-E	Power supply			IFM	
	Volts / Hz	Range +-10%	MCA(A) (50 / 60Hz)	Output(kW)	FLA(A) (50 / 60Hz)
PFFY-P20VLEM-E	220-240V / 50Hz 208-230V / 60Hz	Max.: 264V Min.: 187V	0.24 / 0.31	0.015	0.19 / 0.25
PFFY-P25VLEM-E			0.24 / 0.31	0.015	0.19 / 0.25
PFFY-P32VLEM-E			0.36 / 0.38	0.018	0.29 / 0.30
PFFY-P40VLEM-E			0.40 / 0.41	0.030	0.32 / 0.33
PFFY-P50VLEM-E			0.50 / 0.51	0.035	0.40 / 0.41
PFFY-P63VLEM-E			0.58 / 0.59	0.050	0.46 / 0.47

1. Electrical work

Symbols: MCA : Max.Circuit Amps (=1.25xFLA) FLA : Full Load Amps

IFM :Indoor Fan Motor Output : Fan motor rated output

PFFY-P-VLRM-E	Power supply			IFM	
	Volts / Hz	Range +-10%	MCA(A) (50 / 60Hz)	Output(kW)	FLA(A) (50 / 60Hz)
PFFY-P20VLRM-E	220-240V / 50Hz 208-230V / 60Hz	Max.: 264V Min.: 187V	0.24 / 0.31	0.015	0.19 / 0.25
PFFY-P25VLRM-E			0.24 / 0.31	0.015	0.19 / 0.25
PFFY-P32VLRM-E			0.36 / 0.38	0.018	0.29 / 0.30
PFFY-P40VLRM-E			0.40 / 0.41	0.030	0.32 / 0.33
PFFY-P50VLRM-E			0.50 / 0.51	0.035	0.40 / 0.41
PFFY-P63VLRM-E			0.58 / 0.59	0.050	0.46 / 0.47

PFFY-P-VLRMM-E	Power supply			IFM	
	Volts / Hz	Range +-10%	MCA(A) (50 / 60Hz)	Output(kW)	FLA(A) (50 / 60Hz)
PFFY-P20VLRMM-E	220-240V / 50Hz	Max.: 264V Min.: 198V	0.59 / 0.58	0.096	0.47 / 0.46
PFFY-P25VLRMM-E			0.59 / 0.58	0.096	0.47 / 0.46
PFFY-P32VLRMM-E			0.69 / 0.69	0.096	0.55 / 0.55
PFFY-P40VLRMM-E			0.78 / 0.76	0.096	0.62 / 0.61
PFFY-P50VLRMM-E			0.80 / 0.79	0.096	0.64 / 0.63
PFFY-P63VLRMM-E			0.93 / 0.93	0.096	0.74 / 0.74

GUF-RDH3	Power supply			IFM	
	Volts / Hz	Range +-10%	MCA(A) (50 / 60Hz)	Output(kW)	FLA(A) (50 / 60Hz)
GUF-50RD(H)3	220-240V / 50Hz	Max.: 264V	1.85 / 1.85	0.081x2	1.48 / 1.48
GUF-100RD(H)3	220V / 60Hz	Min.: 198V	3.49 / 3.49	0.16x2	2.79 / 2.79

1. Electrical work

1-2-2. Electrical characteristics of Outdoor unit at cooling mode

Model	Unit Combination	Units			Power supply	Compressor		FAN	RLA (A) (50 / 60Hz)	
		Hz	Volts	Voltage range	MCA(A)	Output (kW)	SC (A)	Output (kW)	Cooling	Heating
PURY-RP200YJM-B(-BS)	-	50/60	380	Max : 456V Min : 342V	11.8	5.4	8	0.92	8.3/7.9/7.6	9.2/8.8/8.5
PURY-RP250YJM-B(-BS)	-		400		16.4	6.8		0.92		
PURY-RP300YJM-B(-BS)	-		415		20.0	7.8		0.92		

1-3. Power cable specifications

Thickness of wire for main power supply, capacities of the switch and system impedance

	Model	Minimum wire thickness (mm ²)			Breaker for current leakage	Local switch (A)		Breaker for wiring (NFB) (A)	Max. Permissible System Impedance
		Main cable	Branch	Ground		Capacity	Fuse		
Outdoor unit	PURY-RP200YJM-B	4	-	4	30A 100mA 0.1sec. or less	25	25	30	*1
	PURY-RP250YJM-B	4	-	4	30A 100mA 0.1sec. or less	25	25	30	*1
	PURY-RP300YJM-B	4	-	4	30A 100mA 0.1sec. or less	32	32	30	*1
Total operating current of the indoor unit	F0 = 20 or less *2	1.5	1.5	1.5	20A current sensitivity *3	20	20	20	(apply to IEC61000-3-3)
	F0 = 30 or less *2	2.5	2.5	2.5	30A current sensitivity *3	30	30	30	(apply to IEC61000-3-3)
	F0 = 40 or less *2	4.0	4.0	4.0	40A current sensitivity *3	40	40	40	(apply to IEC61000-3-3)

*1: Meet technical requirements of IEC61000-3-3

*2: Please take the larger of F1 or F2 as the value for F0.

F1 = Total operating maximum current of the indoor units × 1.2

F2 = (V1 × Quantity of Type A) + (V1 × Quantity of Type B) + (V1 × Quantity of Others)

Indoor unit		V1
Type A	PLFY-VBM, PMFY-VBM, PEFY-VMS1(L), PCFY-VKM, PKFY-VHM, PKFY-VKM, PFFY-VKM, PFFY-VLRMM	1.6
Type B	PEFY-VMA(L)	3.2
Others	Other indoor unit	0

*3: Current sensitivity is calculated using the following formula.

G1 = (V2 × Quantity of Type 1) + (V2 × Quantity of Type 2) + (V2 × Quantity of Others) + (V3 × Wire length [km])

G1	Current sensitivity
30mA or less	30mA 0.1sec. or less
100mA or less	100mA 0.1sec. or less

Indoor unit		V2
Type 1	PLFY-VBM, PMFY-VBM, PEFY-VMS1(L), PCFY-VKM, PKFY-VHM, PKFY-VKM, PFFY-VKM, PFFY-VLRMM	2.4
Type 2	PEFY-VMA(L)	1.6
Others	Other indoor unit	0

Wire thickness (mm ²)	V3
1.5	48
2.5	56
4.0	66

- Use dedicated power supplies for the outdoor unit and indoor unit. Ensure OC and OS are wired individually.
- Bear in mind ambient conditions (ambient temperature, direct sunlight, rain water, etc.) when proceeding with the wiring and connections.
- The wire size is the minimum value for metal conduit wiring. If the voltage drops, use a wire that is one rank thicker in diameter. Make sure the power-supply voltage does not drop more than 10%.
- Specific wiring requirements should adhere to the wiring regulations of the region.
- Power supply cords of parts of appliances for outdoor use shall not be lighter than polychloroprene sheathed flexible cord (design 245 IEC57). For example, use wiring such as YZW.
- A switch with at least 3 mm contact separation in each pole shall be provided by the Air Conditioner installer.

⚠ WARNING

- Be sure to use specified wires for connections and ensure no external force is imparted to terminal connections. If connections are not fixed firmly, heating or fire may result.
- Be sure to use the appropriate type of overcurrent protection switch. Note that generated overcurrent may include some amount of direct current.

⚠ CAUTION

- Some installation sites may require attachment of an earth leakage breaker for the inverter. If no earth leakage breaker is installed, there is a danger of electric shock.
- Do not use anything other than a breaker and fuse with the correct capacity. Using a fuse or wire of too large capacity may cause malfunction or fire.
- Check the existing wires for damage to insulation by measuring the resistance between the lead and the ground with a 500V ohmmeter. If the insulation resistance is less than 100 MΩ, replace the wires.

Note

- This device is intended for the connection to a power supply system with a maximum permissible system impedance shown in the above table at the interface point (power service box) of the user's supply.
- The user must ensure that this device is connected only to a power supply system which fulfils the requirement above. If necessary, the user can ask the public power supply company for the system impedance at the interface point.
- This equipment complies with IEC 61000-3-12 provided that the short-circuit power Ssc is greater than or equal to Ssc(*2) at the interface point between the user's supply and the public system. It is the responsibility of the installer or user of the equipment to ensure, by consultation with the distribution network operator if necessary, that the equipment is connected only to a supply with a short-circuit power Ssc greater than or equal to Ssc(*2).

Ssc(*2)

Model	Ssc(MVA)
PURY-RP200YJM	1.25
PURY-RP250YJM	1.36
PURY-RP300YJM	1.66

1. Electrical work

1-4. Power supply examples

1-4-1.PURY-RP200-300YJM-B

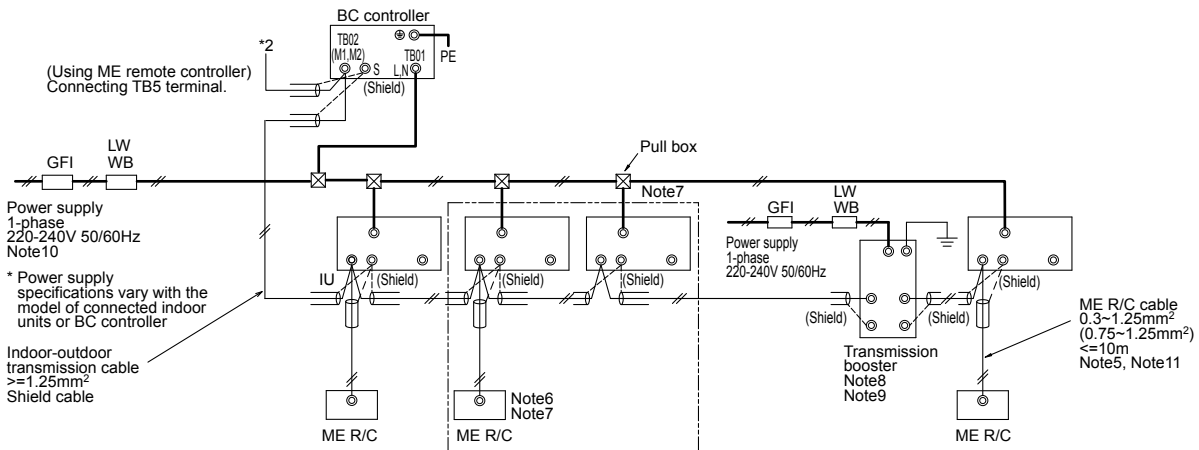
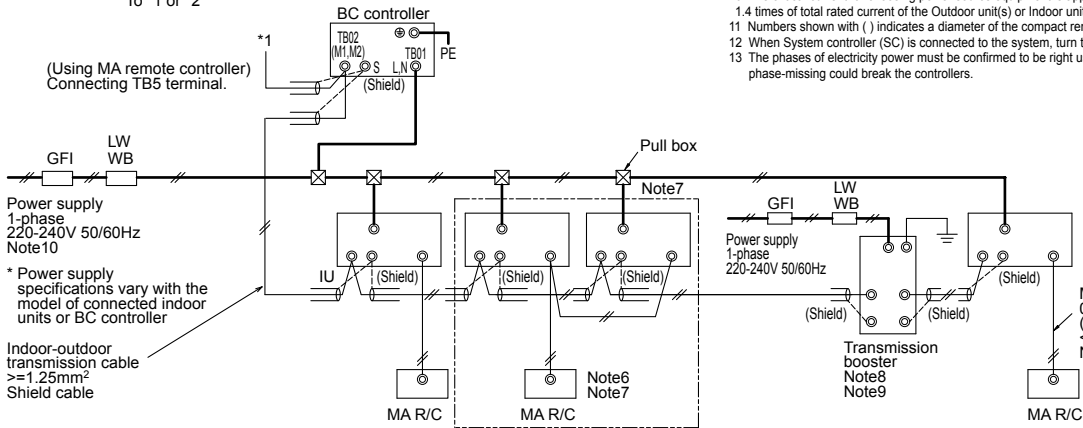
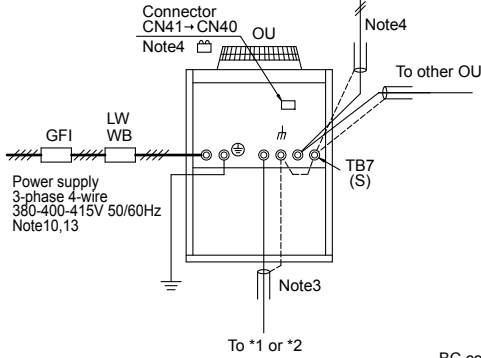
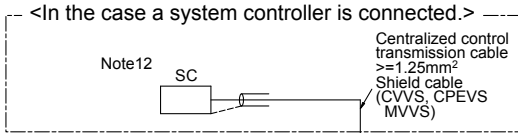

- Note:
- The transmission cable is not-polarity double-wire.
 - Symbol Ⓞ means a screw terminal for wiring.
 - The shield wire of transmission cable should be connected to the grounding terminal at Outdoor unit. All shield wire of M-Net transmission cable among Indoor units should be connected to the S terminal at Indoor unit or all shield wire should be connected together. The broken line at the scheme means shield wire.
 - When the Outdoor unit connected with system controller, power-supply to TB7 of the outdoor unit(s) is needed. The connector change from CN41 to CN40 at one of the outdoor units will enable the outdoor unit to supply power to TB7, or an extra power supplying unit PAC-SC51KUA should be used. The transmission cable (above 1.25mm², shielded, CVVS/CPEVS/MVVS) among Outdoor units and system controllers is called centralized control transmission cable. The shield wire of the centralized control transmission cable must be grounded at the Outdoor unit whose CN41 is changed to CN40.
 - MA R/C transmission cable (0.3-1.25mm²) must be less than 200m in length, while ME R/C transmission cable (0.3-1.25mm²) must be less than 10m in length. But transmission cable to the ME R/C can be extended using a M-NET cable (>=1.25mm²) when the length is counted in the M-Net length. Both Compact MA and ME R/C transmission cables size 0.75-1.25mm² in thickness.
 - MA remote controller and ME remote controller should not be grouped together.
 - If using 1 or 2 (main/sub) MA remote controller to control more than 1 Indoor unit, use MA transmission cable to connect all the TB15 terminals of the Indoor units. It is called "Grouping".
If using 1 or 2 (main/sub) ME remote controller control more than 1 indoor unit, set address to Indoor unit and ME remote controller. For the method, refer to 2-4. "Address Setting".
 - Indoor board consumes power from TB3. The power balance should be considered according to System Design 2-3 "System configuration restrictions".
 - If Transmission booster is needed, be sure to connect the shield wires to the both sides to the booster.
 - The critical current for choosing power source equipment is approximate 1.4 times of total rated current of the Outdoor unit(s) or Indoor unit(s).
 - Numbers shown with () indicates a diameter of the compact remote controller.
 - When System controller (SC) is connected to the system, turn the SW2-1 on.
 - The phases of electricity power must be confirmed to be right used. Phase-reverse, or phase-missing could break the controllers.

Symbol	Model	Ground-fault interrupter *1, *2	Local switch		Wiring breaker (NFB) <A>	Minimum Wire thickness		
			BKC <A>	OCP*3 <A>		Power wire <mm²>	Earth wire <mm²>	
GFI	Ground-fault interrupter	PURY-RP200YJM	30A 100mA 0.1sec. or less	25	25	30	4	4
LW	Local switch	PURY-RP250YJM	30A 100mA 0.1sec. or less	25	25	30	4	4
BKC	Breaker capacity	PURY-RP300YJM	30A 100mA 0.1sec. or less	32	32	30	4	4

*1 The Ground-fault interrupter should support Inverter circuit. (e.g. Mitsubishi Electric's NV-C series or equivalent).
 *2 Ground-fault interrupter should combine using of local switch or wiring breaker.
 *3 It shows data for B-type fuse of the breaker for current leakage.

2. M-NET control

2-1. Transmission cable length limitation

2-1-1. Using MA Remote controller

Long transmission cable causes voltage down, therefore, the length limitation should be obeyed to secure proper transmission.

Max. length via Outdoor (M-NET cable)	$L_1+L_2+L_3+L_4, L_1+L_2+L_6+L_7, L_3+L_4+L_6+L_7$	$\leq 500\text{m}[1640\text{ft.}]$	1.25mm ² [AWG16] or thicker
Max. length to Outdoor (M-NET cable)	$L_1, L_3+L_4, L_6, L_2+L_6, L_7$	$\leq 200\text{m}[656\text{ft.}]$	1.25mm ² [AWG16] or thicker
Max. length from MA to Indoor	$a_1+a_2, a_1+a_2+a_3+a_4$	$\leq 200\text{m}[656\text{ft.}]$	0.3-1.25 mm ² [AWG22-16]
24VDC to AG-150A	n	$\leq 50\text{m}[164\text{ft.}]$	0.75-2.0 mm ² [AWG18-14]

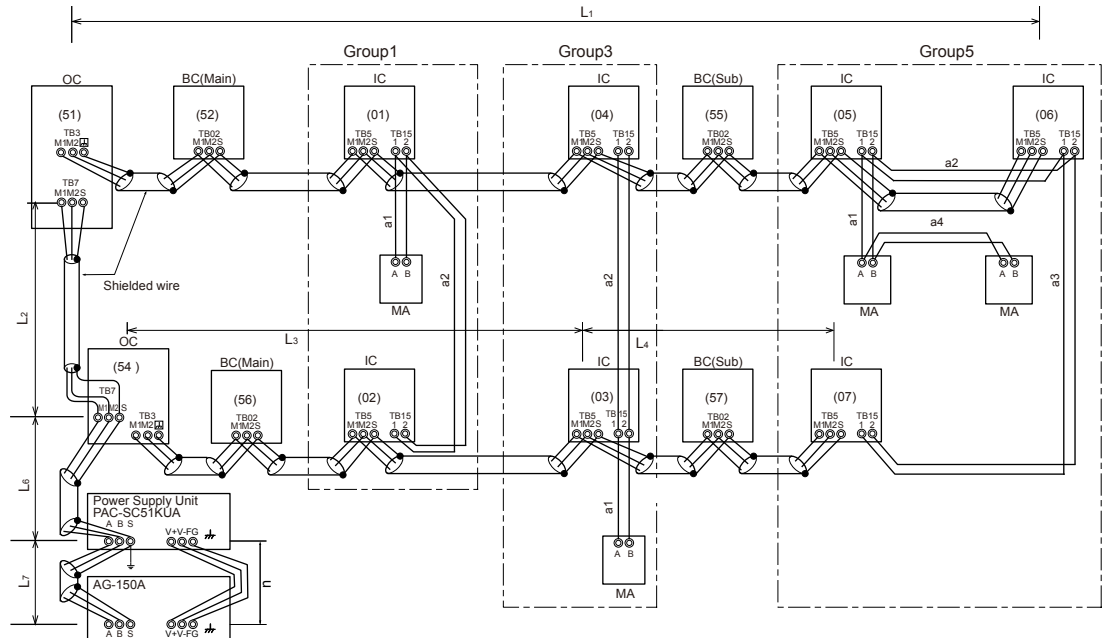

OC : Outdoor unit controller; IC: Indoor unit controller; MA: MA remote controller

2-1-2. Using ME Remote controller

Long transmission cable causes voltage down, therefore, the length limitation should be obeyed to secure proper transmission.

Max. length via Outdoor (M-NET cable)	$L_1+L_2+L_3+L_4, L_1+L_2+L_6+L_7, L_1+L_2+L_3+L_5, L_3+L_4+L_6+L_7$	$\leq 500\text{m}[1640\text{ft.}]$	1.25mm ² [AWG16] or thicker
Max. length to Outdoor (M-NET cable)	$L_1, L_3+L_4, L_6, L_2+L_6, L_7, L_3+L_5$	$\leq 200\text{m}[656\text{ft.}]$	1.25mm ² [AWG16] or thicker
Max. length from ME to Indoor	e_1, e_2+e_3, e_4	$\leq 10\text{m}[32\text{ft.}]^*1$	0.3-1.25 mm ² [AWG22-16] *1
24VDC to AG-150A	n	$\leq 50\text{m}[164\text{ft.}]$	0.75-2.0 mm ² [AWG18-14]

*1. If the length from ME to Indoor exceed 10m, use 1.25 mm² [AWG16] shielded cable, but the total length should be counted into Max. length via Outdoor.

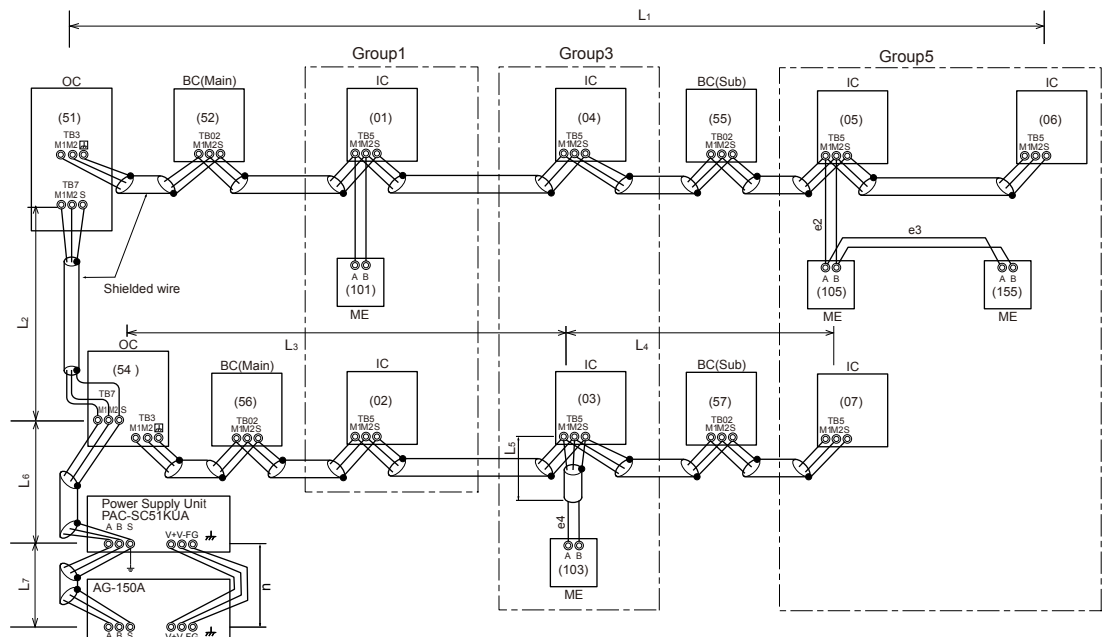

OC : Outdoor unit controller; IC: Indoor unit controller; ME: ME remote controller

2. M-NET control

2-2. Transmission cable specifications

	Transmission cables (Li)	ME Remote controller cables	MA Remote controller cables
Type of cable	Shielding wire (2-core) CVVS, CPEVS or MVVS	Sheathed 2-core cable (unshielded) CVV	
Cable size	More than 1.25mm ² [AWG16]	0.3~1.25mm ² [AWG22~16] (0.75~1.25mm ² [AWG18~16])*1	0.3~1.25mm ² [AWG22~16] (0.75~1.25mm ² [AWG18~16])*1
Remarks	—	When 10m [32ft] is exceeded, use cables with the same specification as transmission cables.	Max length : 200m [656ft]

*1 Connected with simple remote controller.

CVVS, MVVS : PVC insulated PVC jacketed shielded control cable
CPEVS : PE insulated PVC jacketed shielded communication cable
CVV : PV insulated PVC sheathed control cable

CAUTION

Check the existing wires for damage to insulation by measuring the resistance between the lead and the ground with a 500V ohmmeter. If the insulation resistance is less than 100 MΩ, replace the wires.

Disconnect all controllers before measuring insulation resistance to avoid controller damage.

Note: Disconnect the system controller before starting a refrigerant oil recovery operation, if one is connected.

Reconnect the system controller after the completion of the refrigerant oil recovery operation.

2. M-NET control

2-2-1. Reusability check of the existing transmission lines for Replace Multi units

Use the flowcharts on the following pages to determine the reusability of the existing transmission lines. Obtain the system configuration drawing, fill out the checklist, and make a decision based on them.

Existing transmission lines reusability checklist

Check items	Findings	Notes
1. Remote controller cable (MA remote controller)		
(1) Length	m	
(2) Cable size	mm ²	
(3) Number of cores	Cores	
(4) Cable type (shielded/unshielded)	Shielded/Unshielded	
2. Remote controller cable (ME remote controller)		
(1) Length *1	m	
(2) Cable size	mm ²	
(3) Number of cores	Cores	
(4) Cable type (shielded/unshielded)	Shielded/Unshielded	
3. Remote controller cable (system controller)		
(1) Length *1	m	
(2) Cable size	mm ²	
(3) Number of cores	Cores	
(4) Cable type (shielded/unshielded)	Shielded/Unshielded	
(5) System controller connection (Indoor unit system/centralized control system)	Indoor/Centralized	
4. Indoor-outdoor transmission line		
(1) Refrigerant system (Single/Multiple)	Single/Multiple	
(2) Length of transmission line to the farthest unit *1	m	
(3) Cable size	mm ²	
(4) Number of cores	Cores	
(5) Cable type (shielded/unshielded)	Shielded/Unshielded	
(6) Number of connected indoor units	units	
5. Centralized control transmission line		
(1) Length of transmission line to the farthest unit *1	m	
(2) Cable size	mm ²	
(3) Number of cores	Cores	
(4) Cable type (shielded/unshielded)	Shielded/Unshielded	
6. Availability of system configuration drawing (Obtain one as much as possible.)	Available/Not available	
7. Noise-related problems with the old units (Write down the nature of the problem in the "Notes" column, if any.)	Available/Not available	
8. Are there any high-frequency medical equipment in the adjacent area that could cause noise-interference? (Write down the specific nature of the concerns in the "Notes" column, if any.)	Available/Not available	

*1: If the remote controller (ME/System controller) length exceeds 10 m, include the exceeded length in the calculation of the transmission line length (indoor-outdoor transmission line/centralized control system).

2. M-NET control

Reusability of MA remote controller wiring

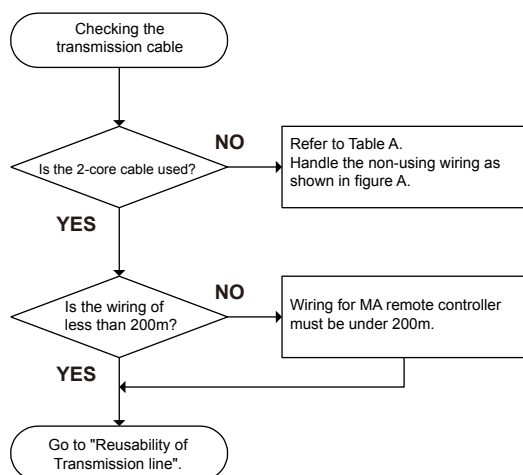

Reusability of M-NET remote controller wiring

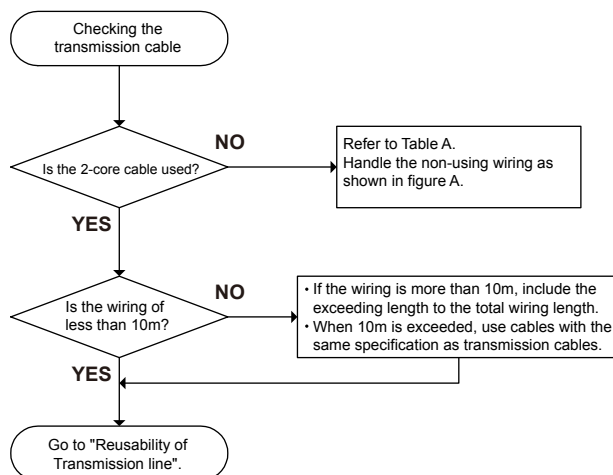

Reusability of System controller wiring

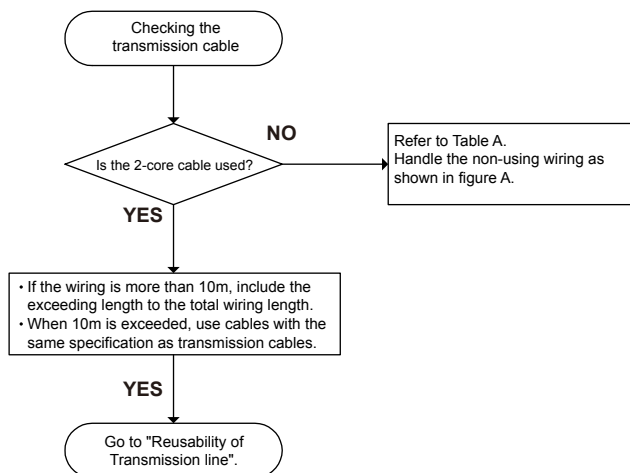
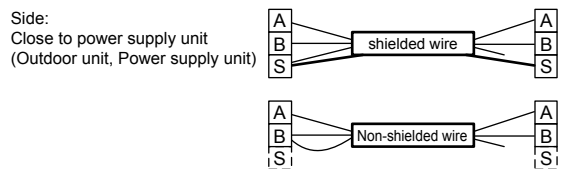

Figure A. Non-using wiring



Non using wiring on the power supply side (Outdoor unit, Power supply unit) should be connected to the shield terminal. The non-using wiring on the opposite side should be open and insulated.

Table A

	Transmission cables (Li)	ME Remote controller cables	MA Remote controller cables
Type of cable	Shielding wire (2-core) CVVS, CPEVS or MVVS	Sheathed 2-core cable (unshielded) CVV	
Cable size	More than 1.25mm ² [AWG16]	0.3 ~ 1.25mm ² [AWG22~16] (0.75 ~ 1.25mm ² [AWG18~16])*1	0.3 ~ 1.25mm ² [AWG22~16] (0.75 ~ 1.25mm ² [AWG18~16])*1
Remarks	—	When 10m [32ft] is exceeded, use cables with the same specification as transmission cables.	Max length : 200m [656ft]

*1 Connected with simple remote controller.

CVVS, MVVS : PVC insulated PVC jacketed shielded control cable
CPEVS : PE insulated PVC jacketed shielded communication cable
CVV : PV insulated PVC sheathed control cable

2. M-NET control

Determining the reusability of the transmission line

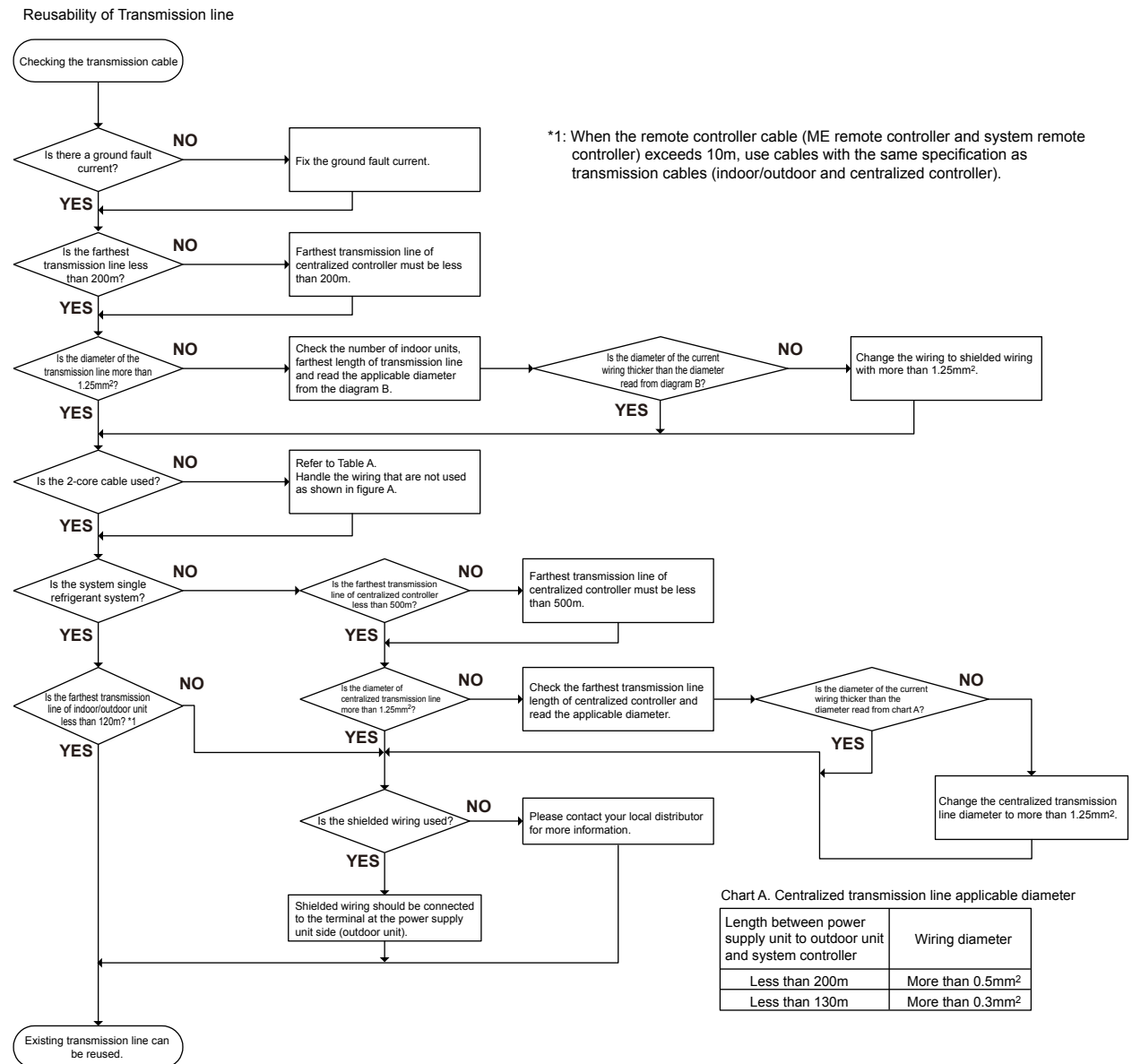
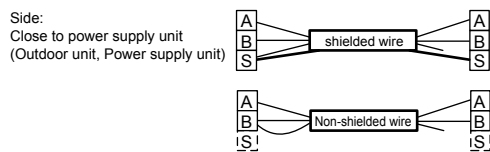

Figure A. Non-using wiring



Non using wiring on the power supply side (Outdoor unit, Power supply unit) should be connected to the shield terminal. The non-using wiring on the opposite side should be open and insulated.

Table A

	Transmission cables (Li)	ME Remote controller cables	MA Remote controller cables
Type of cable	Shielding wire (2-core) CVVS, CPEVS or MVVS	Sheathed 2-core cable (unshielded) CVV	
Cable size	More than 1.25mm ² [AWG16]	0.3 ~ 1.25mm ² [AWG22~16] (0.75 ~ 1.25mm ² [AWG18~16])*1	0.3 ~ 1.25mm ² [AWG22~16] (0.75 ~ 1.25mm ² [AWG18~16])*1
Remarks	—	When 10m [32ft] is exceeded, use cables with the same specification as transmission cables.	Max length : 200m [656ft]

*1 Connected with simple remote controller.

CVVS, MVVS : PVC insulated PVC jacketed shielded control cable
CPEVS : PE insulated PVC jacketed shielded communication cable
CVV : PV insulated PVC sheathed control cable

2. M-NET control

Diagram B Checking the cable size

MA remote controller

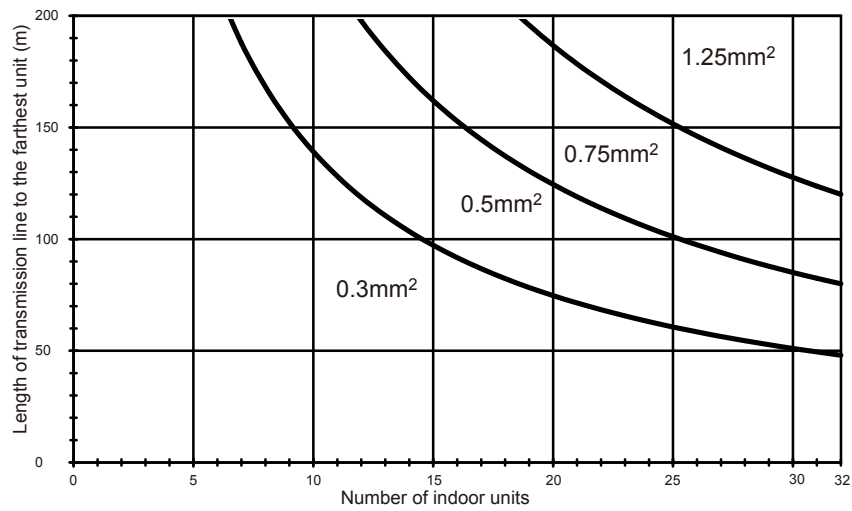

ME remote controller

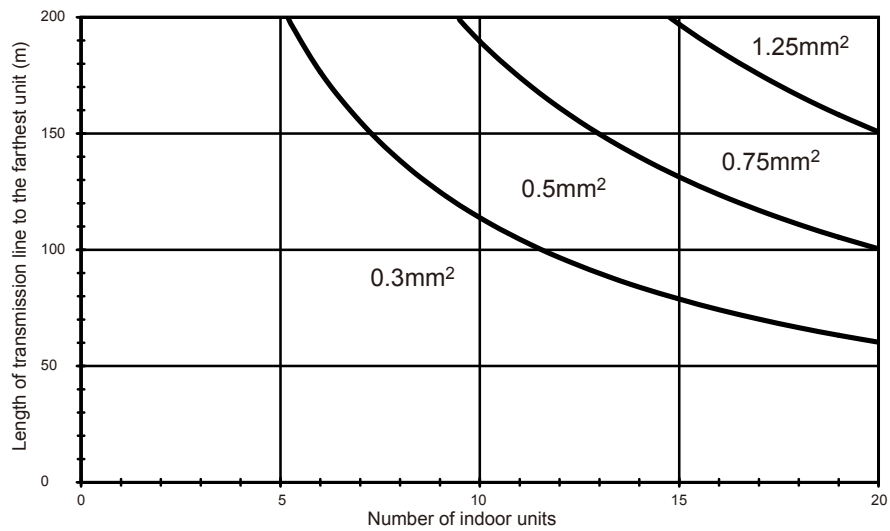

2. M-NET control

2-3. System configuration restrictions

2-3-1. Common restrictions for the CITYMULTI system

For each Outdoor unit, the maximum connectable quantity of Indoor unit is specified at its Specifications table.

- A) 1 Group of Indoor units can have 1-16 Indoor units;
*OA processing unit GUF-RD(H) is considered as Indoor unit.
 - B) Maximum 2 remote controllers for 1 Group; (MA/ME remote controllers cannot be present together in 1group.)
 - C) 1 LOSSNAY unit can interlock maximum 16 Indoor units; 1 Indoor unit can interlock only 1 LOSSNAY unit.
 - D) Maximum 3 System controllers are connectable when connecting to TB3 of the Outdoor unit.
 - E) Maximum 3 System controllers are connectable when connecting to TB7 of the Outdoor unit, if the transmission power is supplied by the Outdoor unit.
 - F) 4 System controllers or more are connectable when connecting to TB7 of the Outdoor unit, if the transmission power is supplied by the power supply unit PAC-SC51KUA. Details refer to 2-3-3-C.
- *System controller connected as described in D) and E) would have a risk that the failure of connected Outdoor unit would stop power supply to the System controller.

2-3-2. Ensuring proper communication power for M-NET

In order to ensure proper communication among Outdoor unit, Indoor unit, LOSSNAY, and OA processing unit GUF-RD(H), and Controllers, the transmission power situation for the M-NET should be observed. In some cases, Transmission booster should be used. Taking the power consumption of Indoor unit sized P20-P140 as 1, the equivalent power consumption or supply of others are listed at Table 2-3-1 and Table 2-3-2.

Table 2-3-1 The equivalent power consumption

Indoor, OA unit	Indoor unit	BC controller	MARC. LOSSNAY	ME Remote Contr.	Timers, System Contr.	ON/OFF Contr.	MN Converter		
Sized P15-P140 GUF-50, 100	Sized P200,P250	CMB	PAR-30MAA PAR-21MAA PAC-YT51CRA(B) PAR-FA32MA LGH-RX-E PZ-60DR-E	PAR-F27MEA PAC-SE51CRA PZ-52SF-E	PAC-SC30GRA PAC-SF44SRA PAC-YT34STA AG-150A	AT-50A	PAC-YT40ANRA	CMS -MNF-B	CMS -MNG-E
1	7	2	0	1/4	1/2	4	1	1/2	2

*RC : Remote Controller

Table 2-3-2 The equivalent power supply

Transmission Booster	Power supply unit	Expansion controller	BM ADAPTER	System Controller	Outdoor unit	Outdoor unit
PAC-SF46EPA	PAC-SC51KUA	PAC-YG50ECA	BAC-HD150	GB-50ADA	Connector TB3 and TB7 total *	Connector TB7 only
25	5	6	6	6	32	6

*If PAC-SC51KUA is used to supply power at TB7 side, no power supply need from Outdoor unit at TB7, Connector TB3 itself will therefore have 32. Not applicable to the PUMY model.

With the equivalent power consumption values in Table 2-3-1 and Table 2-3-2, PAC-SF46EPA can be designed into the air-conditioner system to ensure proper system communication according to 2-3-2-A, B, C.

2-3-2-A) Firstly, count from TB3 at TB3 side the total quantity of Indoor units, OA process units and ME remote controller, Timers and System controllers. If the total quantity reaches 40, a PAC-SF46EPA should be set. In this case, Indoor unit sized P200, 250 is counted as 7 Indoor units, but MA remote controller(s), LOSSNAY, PZ-60DR-E is NOT counted.

2-3-2-B) Secondly, count from TB7 side to TB3 side the total transmission power consumption. If the total power consumption reaches 32, a PAC-SF46EPA should be set. Yet, if a PAC-SC51KUA is used to supply power at TB7 side, count from TB3 side only.

2-3-2-C) Thirdly, count from TB7 at TB7 side the total transmission power consumption, If the total power consumption reaches 6, a PAC-SF46EPA should be set.

■ System example

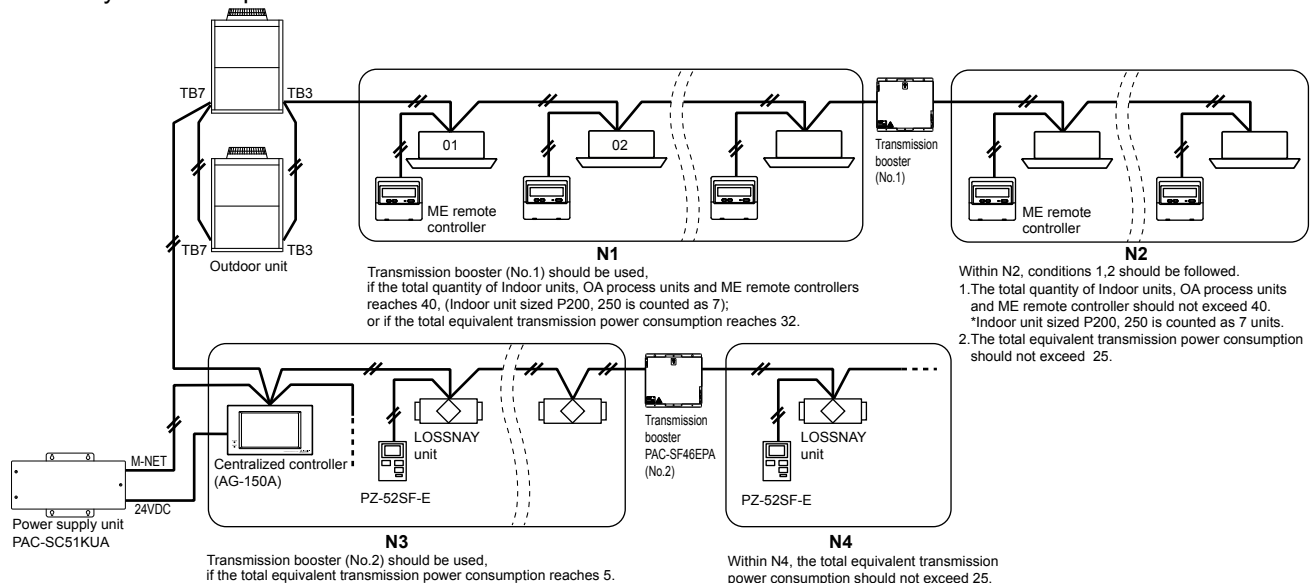

2. M-NET control

2-3-3. Ensuring proper power supply to System controller

The power to System controller (excluding LMAP02-E) is supplied via M-NET transmission line. M-NET transmission line at TB7 side is called Centralized control transmission line while one at TB3 side is called Indoor-Outdoor transmission line. There are 3 ways to supply power to the System controller .

- Connecting to TB3 of the Outdoor unit and receiving power from the Outdoor unit.
- Connecting to TB7 of the Outdoor unit and receiving power from the Outdoor unit.
- Connecting to TB7 of the Outdoor unit but receiving power from power supply unit PAC-SC51KUA.

2-3-3-A. When connecting to TB3 of the Outdoor unit and receiving power from the Outdoor unit.

Maximum 3 System controllers can be connected to TB3. If there is more than 1 Outdoor unit, it is necessary to replace power supply switch connector CN41 with CN40 on one Outdoor unit.

Fig. 2-3-3-A

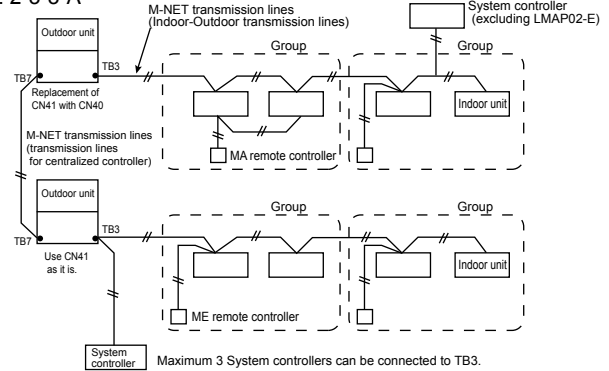

2-3-3-B. When connecting to TB7 of the Outdoor unit and receiving power from the Outdoor unit.

Maximum 3 System controllers can be connected to TB7 and receiving power from the Outdoor unit. It is necessary to replace power supply switch connector CN41 with CN40 on one Outdoor unit.

Fig. 2-3-3-B

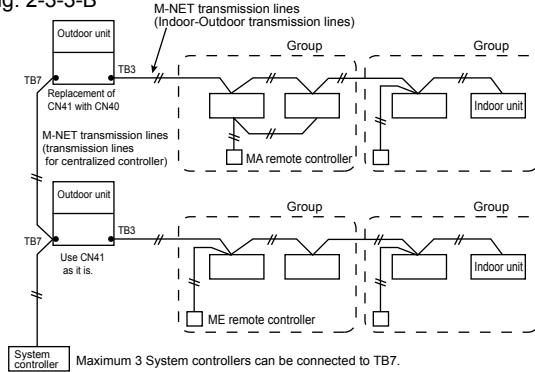

2-3-3-C. When connecting to TB7 of the Outdoor unit but receiving power from PAC-SC51KUA.

When using PAC-SC51KUA to supply transmission power, the power supply connector CN41 on the Outdoor units should be kept as it is. It is also a factory setting. 1 PAC-SC51KUA supports maximum 1 AG-150A unit due to the limited power 24VDC at its TB3. However, 1 PAC-SC51KUA supplies transmission power at its TB2 equal to 5 Indoor units, which is referable at Table 2-3-2.

If PZ-52SF-E, Timers, System controller, ON/OFF controller connected to TB7 consume transmission power more than 5 (Indoor units), Transmission booster PAC-SF46EPA is needed. PAC-SF46EPA supplies transmission power equal to 25 Indoor units.

Fig. 2-3-3-C

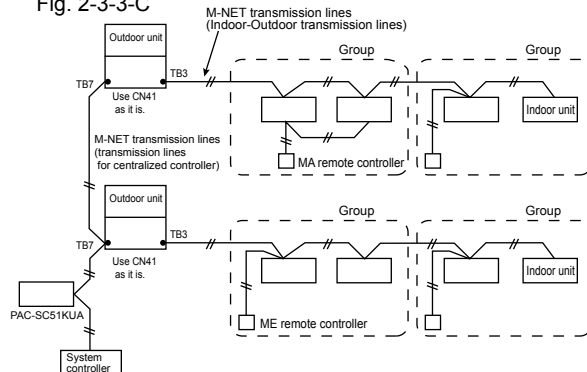

CAUTION

AG-150A*1 is recommended to connect to TB7 because it performs back-up to a number of data.

In an air conditioner system has more than 1 Outdoor units, AG-150A receiving transmission power through TB7 on one of the Outdoor units would have a risk that the connected Outdoor unit failure would stop power supply to AG-150A, and disrupt the whole system.

When applying apportioned electric power function, AG-150A is necessary to connected to TB7 and has its own power supply unit PAC-SC51KUA.*2

*1: AG-150A is an example model of system controllers.

*2: Power supply unit PAC-SC51KUA is for AG-150A.

2. M-NET control

2-3-4. Power supply to LM adapter LMAP02-E

1-phase 220-240VAC power supply is needed.

The power supply unit PAC-SC51KUA is not necessary when connecting only the LMAP02-E. Yet, make sure to change the power supply changeover connector CN41 to CN40 on the LM adapter.

2-3-5. Power supply to expansion controller

1-phase 100-240VAC power supply is needed.

The power supply unit PAC-SC51KUA is not necessary.

The expansion controller supplies power through TB3, which equals 6 indoor units. (refer to Table 2-3-2)

2-3-6. Power supply to BM ADAPTER

1-phase 100-240VAC power supply is needed.

The power supply unit PAC-SC51KUA is not necessary when only BM ADAPTER is connected.

Yet, make sure to move the power jumper from CN41 to CN40 on the BM ADAPTER.

2-3-7. Power supply to GB-50ADA

1-phase 100-240VAC power supply is needed.

The power supply unit PAC-SC51KUA is not necessary.

GB-50ADA supplies power through TB3, which equals 6 indoor units. (refer to Table 2-3-2)

2. M-NET control

2-4. Address setting

2-4-1. Switch operation

In order to constitute CITY MULTI in a complete system, switch operation for setting the unit address No. and connection No. is required.

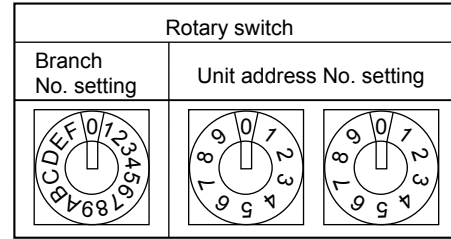

① Address No. of outdoor unit, indoor unit and remote controller.

The address No. is set at the address setting board.

In the case of R2 system, it is necessary to set the same No. at the branch No. switch of indoor unit as that of the BC controller connected. (When connecting two or more branches, use the lowest branch No.)

② Caution for switch operations

- Be sure to shut off power source before switch setting. If operated with power source on, switch can not operate properly.
- No units with identical unit address shall exist in one whole air conditioner system. If set erroneously, the system can not operate.

③ MA remote controller

- When connecting only one remote controller to one group, it is always the main remote controller. When connecting two remote controllers to one group, set one remote controller as the main remote controller and the other as the sub remote controller.
- The factory setting is "Main".

PAR-21MAA

The MA remote controller does not have the switches listed above.
Refer to the installation manual for the function setting.

PAC-YT51CRB































Setting the dip switches

There are switches on the front of the remote controller. Remote controller Main/Sub and other function settings are performed using these switches. Ordinarily, only change the Main/Sub setting of SW1. (The factory settings are all "ON".)

SW No	SW contents Main	ON	OFF	Comment
1	Remote controller Main/Sub setting	Main	Sub	Set one of the two remote controllers at one group to "Main"
2	Temperature display units setting	Celsius	Fahrenheit	When the temperature is displayed in [Fahrenheit], set to "No".
3	Cooling/heating display in AUTO mode	Yes	No	When you do not want to display "Cooling" and "Heating" in the Auto mode, set to "No".

2. M-NET control

2-4-2. Rule of setting address

Unit	Address setting	Example	Note	
Indoor unit	01 ~ 50	 	Use the most recent address within the same group of indoor units. Make the indoor units address connected to the BC controller (Sub) larger than the indoor units address connected to the BC controller (Main). If applicable, set the sub BC controllers in an PURY system in the following order: (1) Indoor unit to be connected to the BC controller (Main) (2) Indoor unit to be connected to the BC controller (No.1 Sub) (3) Indoor unit to be connected to the BC controller (No.2 Sub) Set the address so that (1)<(2)<(3)	
Outdoor unit	51 ~ 99, 100 (Note1)	 	The smallest address of indoor unit in same refrigerant system + 50 Assign sequential address numbers to the outdoor units in one refrigerant circuit system. OC, OS1 and OS2 are automatically detected. (Note 2) * Please reset one of them to an address between 51 and 99 when two addresses overlap. * The address automatically becomes "100" if it is set as "01~ 50"	
BC controller (Main)	52 ~ 99, 100	 	The address of outdoor unit + 1 * Please reset one of them to an address between 51 and 99 when two addresses overlap. * The address automatically becomes "100" if it is set as "01~ 50"	
BC controller (Sub)	52 ~ 99, 100	 	Lowest address within the indoor units connected to the BC controller (Sub) plus 50.	
Local remote controller	ME, LOSSNAY Remote controller (Main)	101 ~ 150 Fixed	 	The smallest address of indoor unit in the group + 100 * The place of "100" is fixed to "1"
	ME, LOSSNAY Remote controller (Sub)	151 ~ 199, 200 Fixed	 	The address of main remote controller + 50 * The address automatically becomes "200" if it is set as "00"
System controller	Group remote controller	201 ~ 250 Fixed	 	The smallest group No. to be managed + 200
	System remote controller	000, 201 ~ 250	  	
	ON/OFF remote controller	000, 201 ~ 250	  	The smallest group No. to be managed + 200 * The smallest group No. to be managed is changeable.
	AG-150A GB-50ADA AT-50A	000, 201 ~ 250	  	
	PAC-YG50ECA	000, 201 ~ 250	  	* Settings are made on the initial screen of AG-150A.
	BAC-HD150	000, 201 ~ 250	  	* Settings are made with setting tool of BM ADAPTER.
	LMAP02-E	201 ~ 250 Fixed	 	

Note1: To set the address to "100", set it to "50"

Note2: Outdoor units OC, OS1 and OS2 in one refrigerant circuit system are automatically detected.

OC, OS1 and OS2 are ranked in descending order of capacity. If units are the same capacity, they are ranked in ascending order of their address.

2. M-NET control

2-4-3. System examples

Factory setting

Original switch setting of the outdoors, indoors, controllers, LMAP and BM ADAPTER at shipment is as follows.

- Outdoor unit : Address: 00, CN41: U (Jumper), DipSW2-1: OFF
- Indoor unit : Address: 00
- BC controller : Address: 00
- ME remote controller : Address: 101
- LMAP : Address: 247, CN41: U (Jumper), DipSW1-2: OFF
- BM ADAPTER : Address: 00

Setting at the site

- DipSW2-1(Outdoor) : When the System Controller is used, all the Dip SW2-1 at the outdoor units should be set to "ON". * Dip SW2-1 remains OFF when only LMAP02-E is used.
- DipSW4-6(BC controller) : Set DipSW 4-6 to ON at BC controller, in case of connected Indoor unit sized P100-P140 with 2 ports. It is also possible to connect Indoor unit sized P100-P140 with 1 port (set DipSW 4-6 to OFF).
- DipSW1-2(LMAP) : When the LMAP is used together with System Controller, DipSW1-2 at the LMAP should be set to "ON".
- CN40/CN41 : Change jumper from CN41 to CN 40 at outdoor control board will activate central transmission power supply to TB7;
(Change jumper at only one outdoor unit when activating the transmission power supply without using a power supply unit.)
Change jumper from CN41 to CN 40 at LMAP will activate transmission power supply to LMAP itself;
Power supply unit is recommended to use for a system having more than 1 outdoor unit, because the central transmission power supply from TB7 of one of outdoor units is risking that the outdoor unit failure may let down the whole system controller system.

2-4-3-1. MA remote controller, Single-refrigerant-system, No System Controller

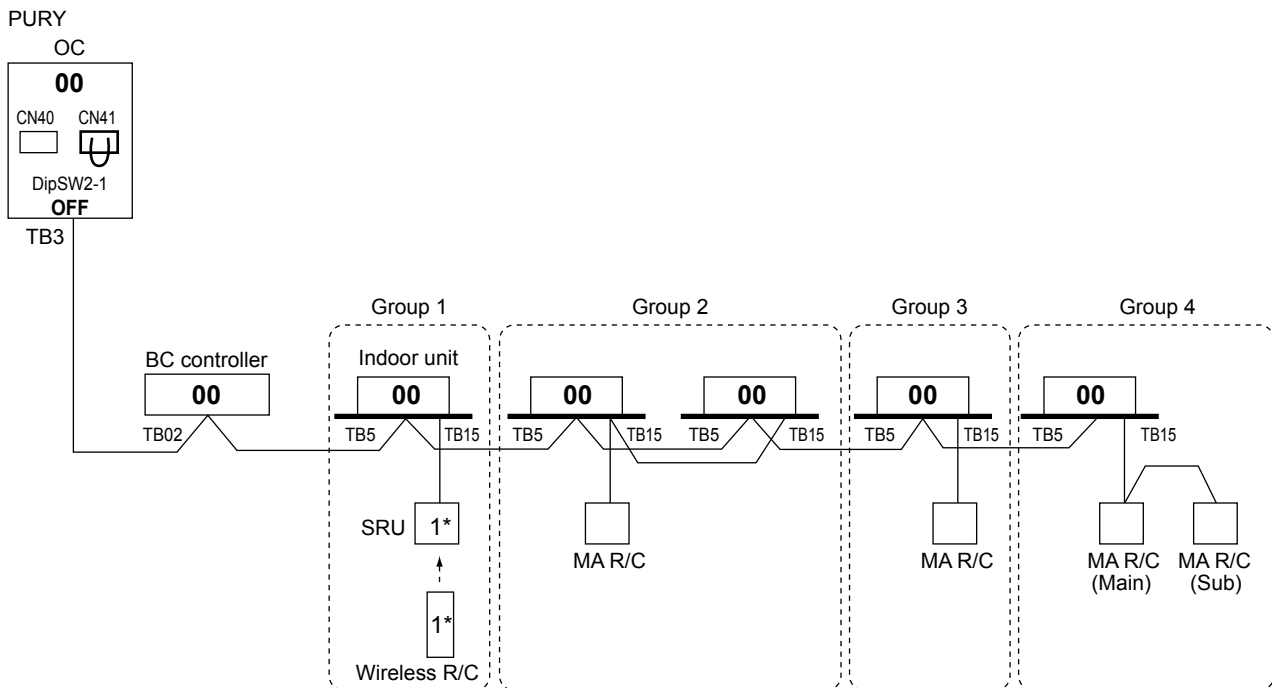

*1 For Wireless R/C and Signal receiver unit (SRU), channel 1, 2 and 3 are selectable and should be set to same channel.

NOTE:

1. No address setting is needed.
2. For a system having more than 32 indoor unit (P15-P140), confirm the need of Booster at 2-3 "System configuration restrictions".
3. Indoor units should be set with a branch number.
4. Address setting is required if a sub BC controller is connected.

2. M-NET control

2-4-3-2. MA remote controller, Single-refrigerant-system, System Controller

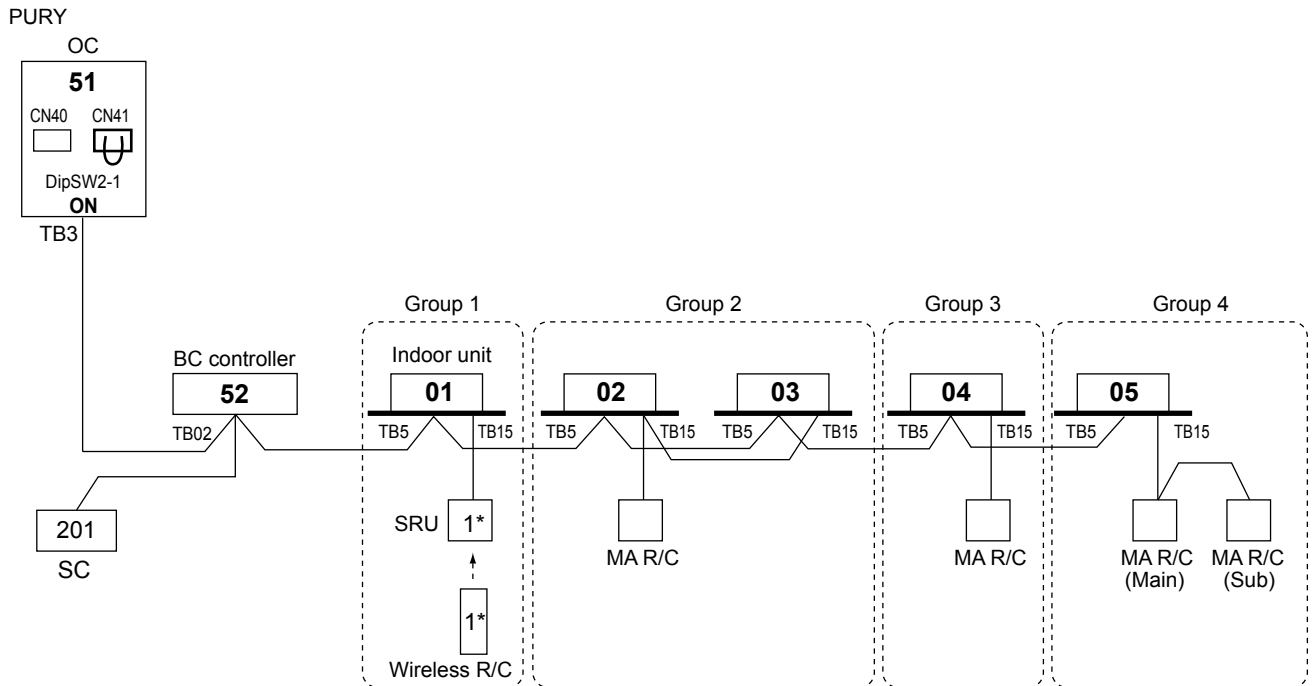

*1 For Wireless R/C and Signal receiver unit (SRU), channel 1, 2 and 3 are selectable and should be set to same channel.

*SC can be connected to TB3 side or TB7 side;

Should SC connected to TB7 side, change Jumper from CN41 to CN40 at the Outdoor unit module so as to supply power to the SC.

NOTE:

1. Address should be set to Indoor units and centralized controller.
2. For a system having more than 32 indoor unit (P15-P140), confirm the need of Booster at 2-3 "System configuration restrictions".
3. Indoor units should be set with a branch number.

2. M-NET control

2-4-3-3. MA remote controller, Multi-refrigerant-system, System Controller at TB7/ TB3 side, Booster for long M-NET wiring

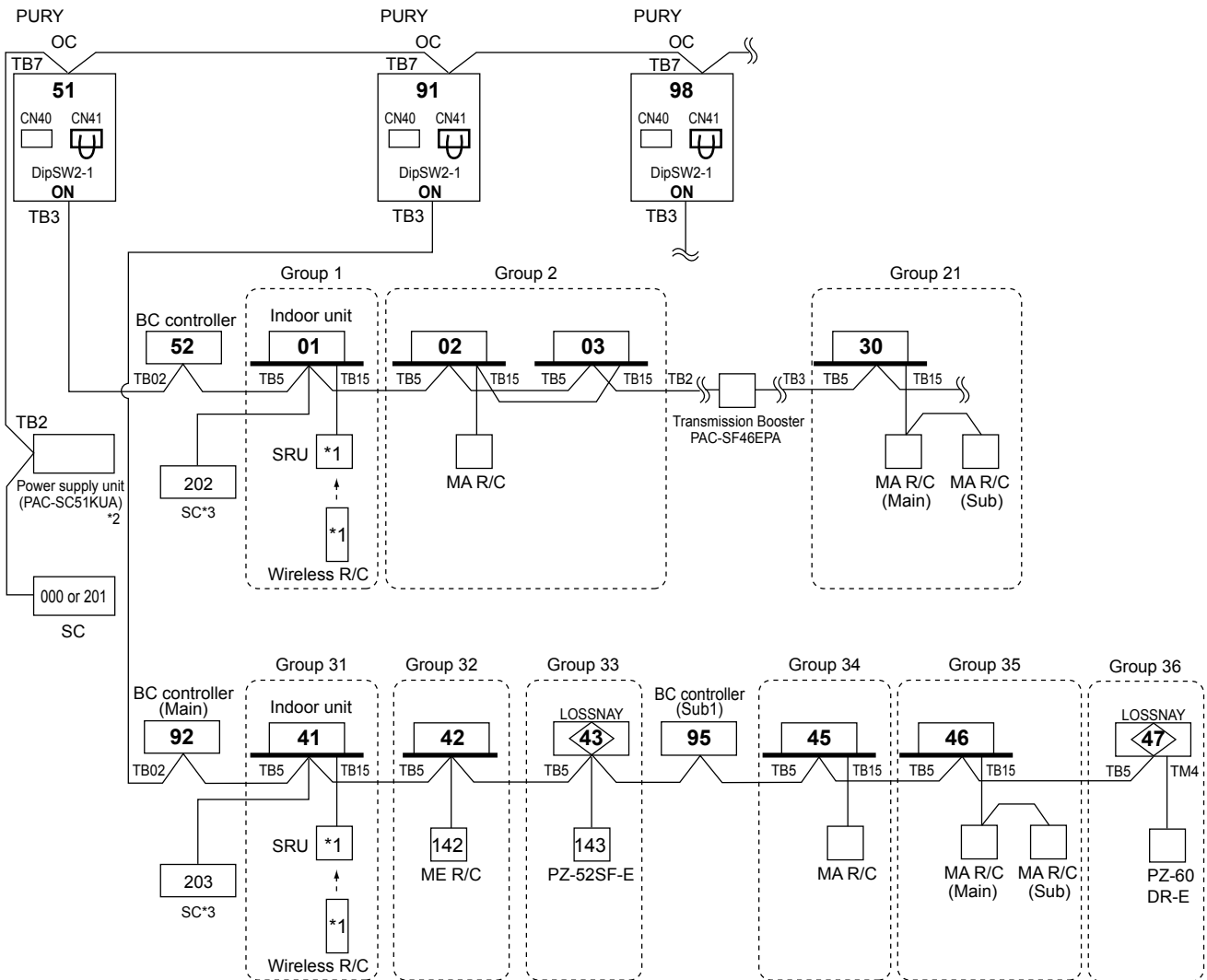

*1 For Wireless R/C and Signal receiver unit (SRU), channel 1, 2 and 3 are selectable and should be set to same channel.

*2 System controller should connect to TB7 at Outdoor and use power supply unit together in Multi-Refrigerant-System.

For AG-150A, 24VDC should be used with the PAC-SC51KUA.

*3 When multiple system controllers are connected in the system, set the controller with more functions than others as a "main" controller and others as "sub".

Make the setting to only one of the system controllers for "prohibition of operation from local remote controller".

NOTE:

1. Address should be set to Indoor units, LOSSNAY and system controller.
2. M-NET power is supplied by the Outdoor unit at TB3, while Indoor unit and ME remote controller consume the M-NET power for transmission use. The power balance is needed to consider for long M-NET wiring. Details refer to

2-3 "System configuration restrictions".

3. Indoor units should be set with a branch number.
4. Assign an address to each of the sub BC controllers which equals the sum of the smallest address of the indoor units that are connected to each sub BC controller and 50.

2. M-NET control

2-4-3-4. ME remote controller, Single-refrigerant-system, No system controller

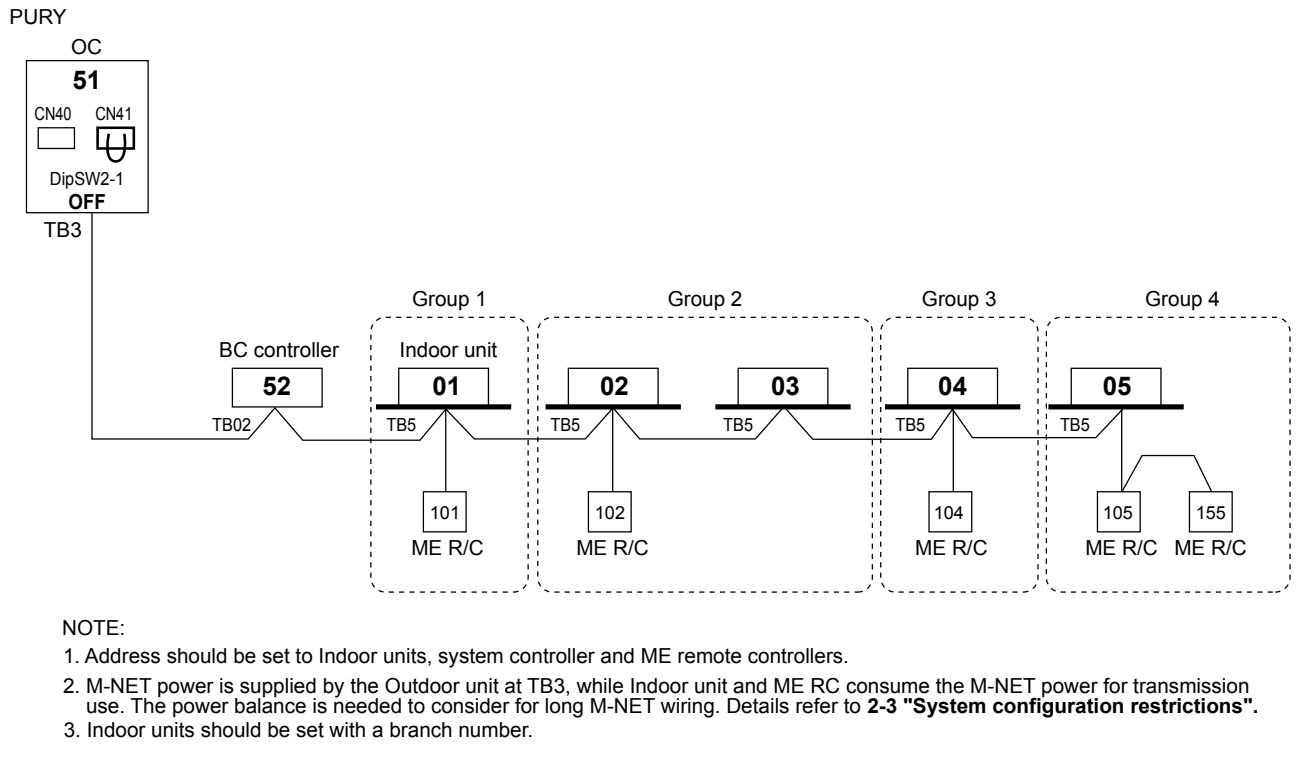

2-4-3-5. ME remote controller, Single-refrigerant-system, System controller, LOSSNAY

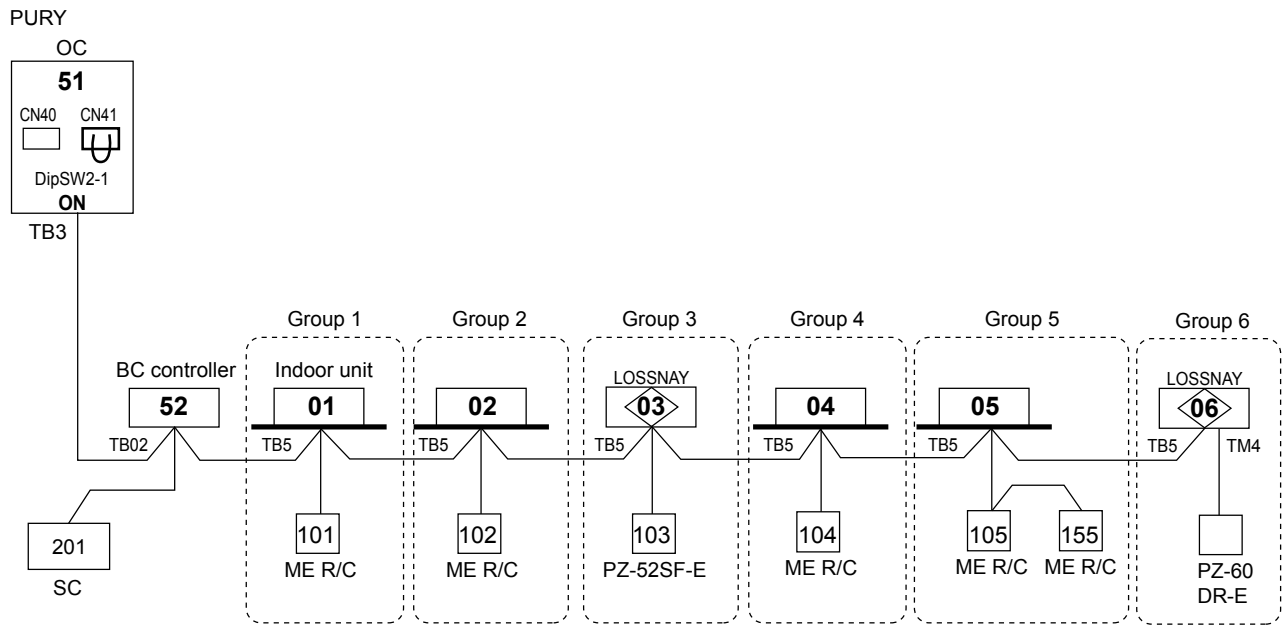

*SC can be connected to TB3 side or TB7 side;

Should SC connected to TB7 side, change Jumper from CN41 to CN40 at the Outdoor unit module so as to supply power to the SC.

NOTE:

1. Address should be set to Indoor units, LOSSNAY centralized controller, ME remote controllers.
2. For a system having more than 32 indoor unit (P15-P140), confirm the need of Booster at 2-3 "System configuration restrictions".
3. Indoor units should be set with a branch number.

2. M-NET control

2-4-3-6. ME remote controller, Multi-refrigerant-system, System Controller at TB7 side, LOSSNAY, Booster for long M-NET wiring

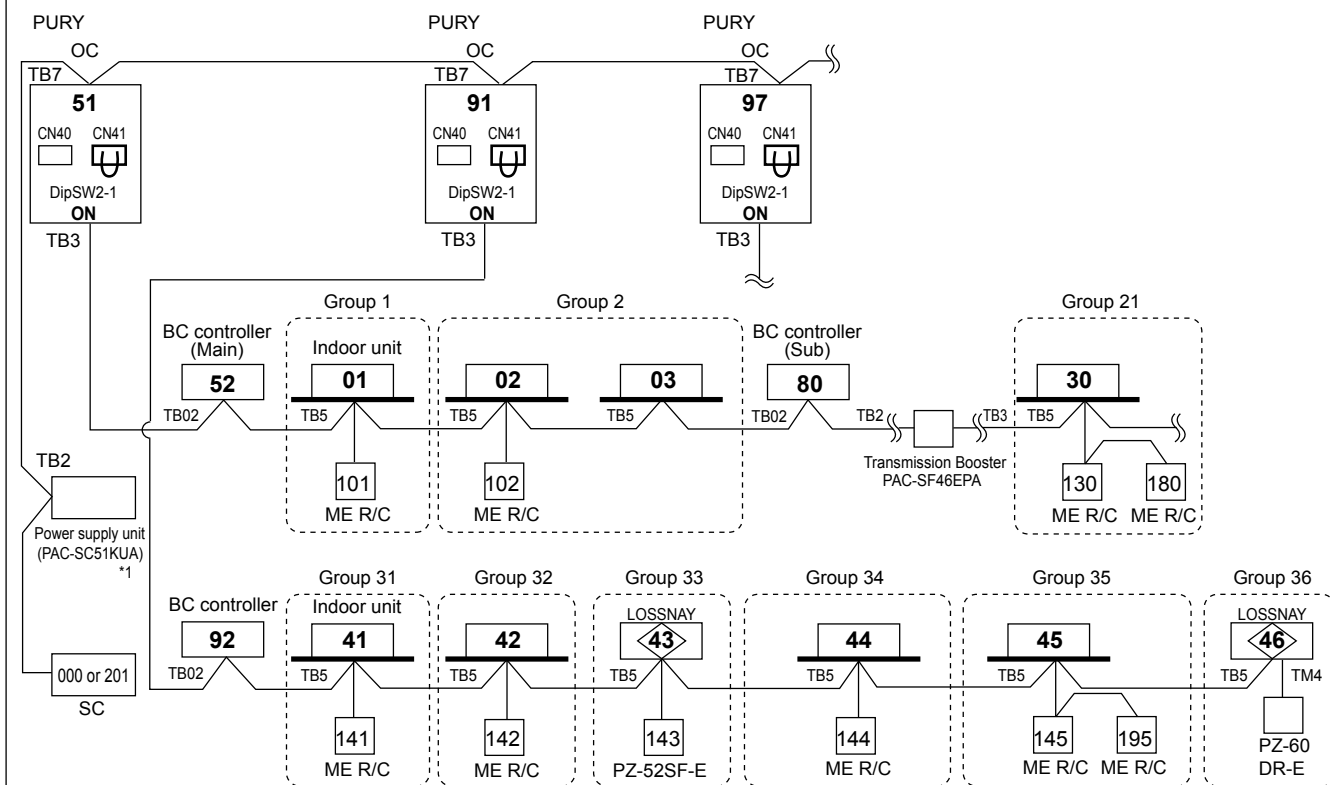

*1 System controller should connect to TB7 at Outdoor and use power supply unit together in Multi-Refrigerant-System.
For AG-150A, 24VDC should be used with the PAC-SC51KUA.

NOTE:

- M-NET power is supplied by the Outdoor unit at TB3, while Indoor unit and ME RC consume the M-NET power for transmission use. The power balance is needed to consider for long M-NET wiring. Details refer to **2-3 "System configuration restrictions"**.
- Indoor units should be set with a branch number.
- Assign an address to each of the sub BC controllers which equals the sum of the smallest address of the indoor units that are connected to each sub BC controller and 50.
When the address assigned to sub BC controller overlaps those of any other units including outdoor units (OC/OS) or main BC controller, sub BC controller will be given priority to have the address.

2-4-3-7. Example : BC, BC sub

NOTE

- Indoor units should be set with a branch number.
 - BC (main) address = O/U address + 1
 - BC (sub) address = Lowest address within the indoor units connected to the BC controller (sub) + 50
- If applicable, set the sub BC controllers in an PURY system in the following order:
- Indoor unit to be connected to the BC controller (Main)
 - Indoor unit to be connected to the BC controller (No.1 Sub)
 - Indoor unit to be connected to the BC controller (No.2 Sub)
- Set the address so that (1)<(2)<(3)

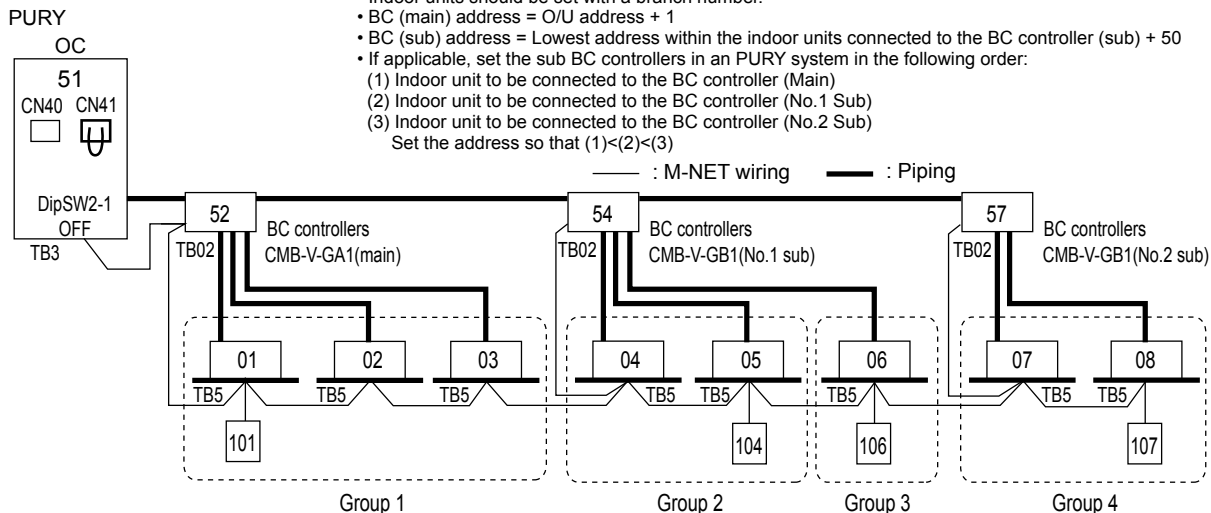

2. M-NET control

2-4-3-8. ME remote controller, Multi-refrigerant-system, No Power supply unit

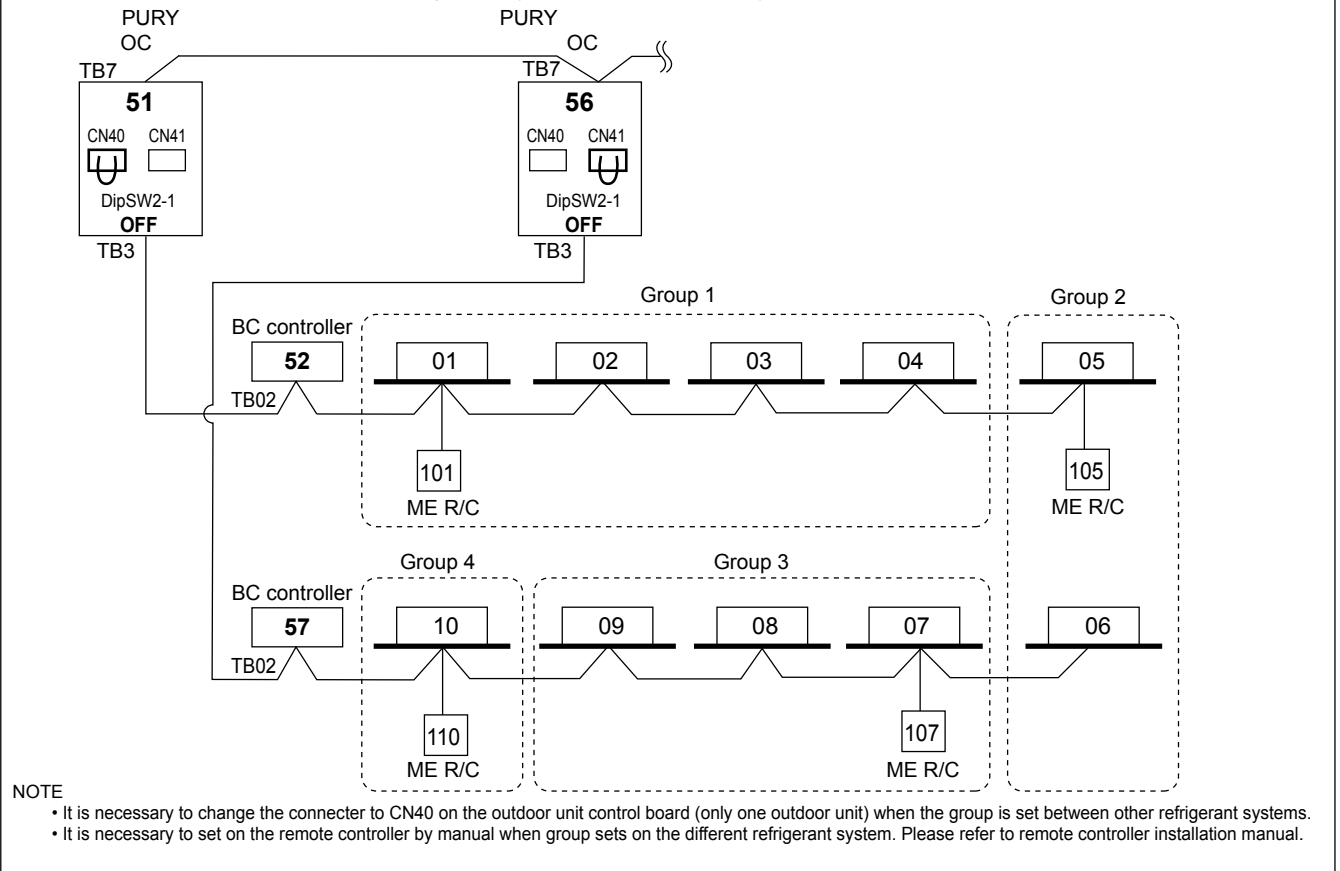

2-4-3-9. ME remote controller, Multi-refrigerant-system, System Controller at TB7 side, No Power supply unit

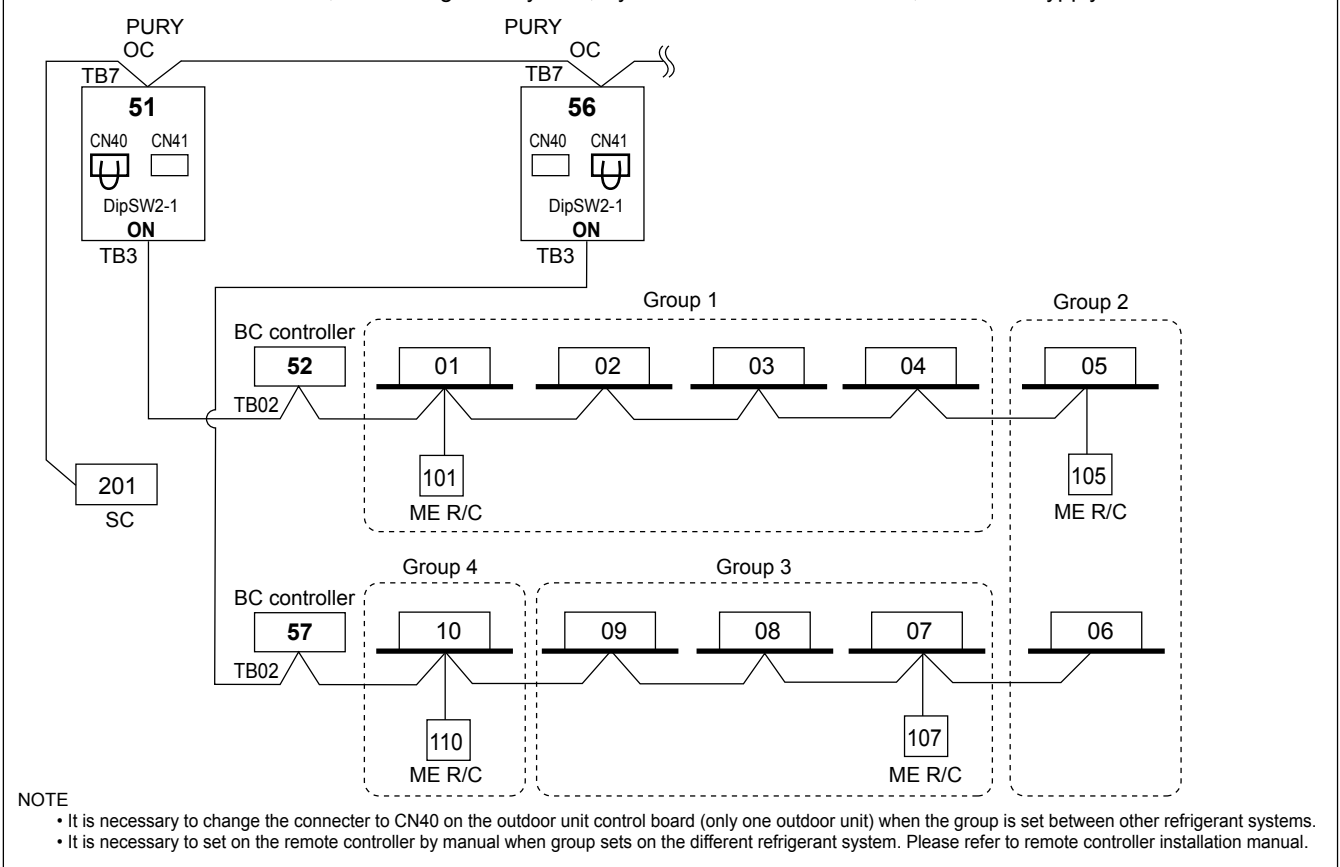

2. M-NET control

2-4-3-10. TG-2000A(*1)+AG-150A(*2)

AG-150A can control max. 50 indoor units;

TG-2000A can control max. 40 AG-150A;*3

TG-2000A can control max. 2000 indoor units.

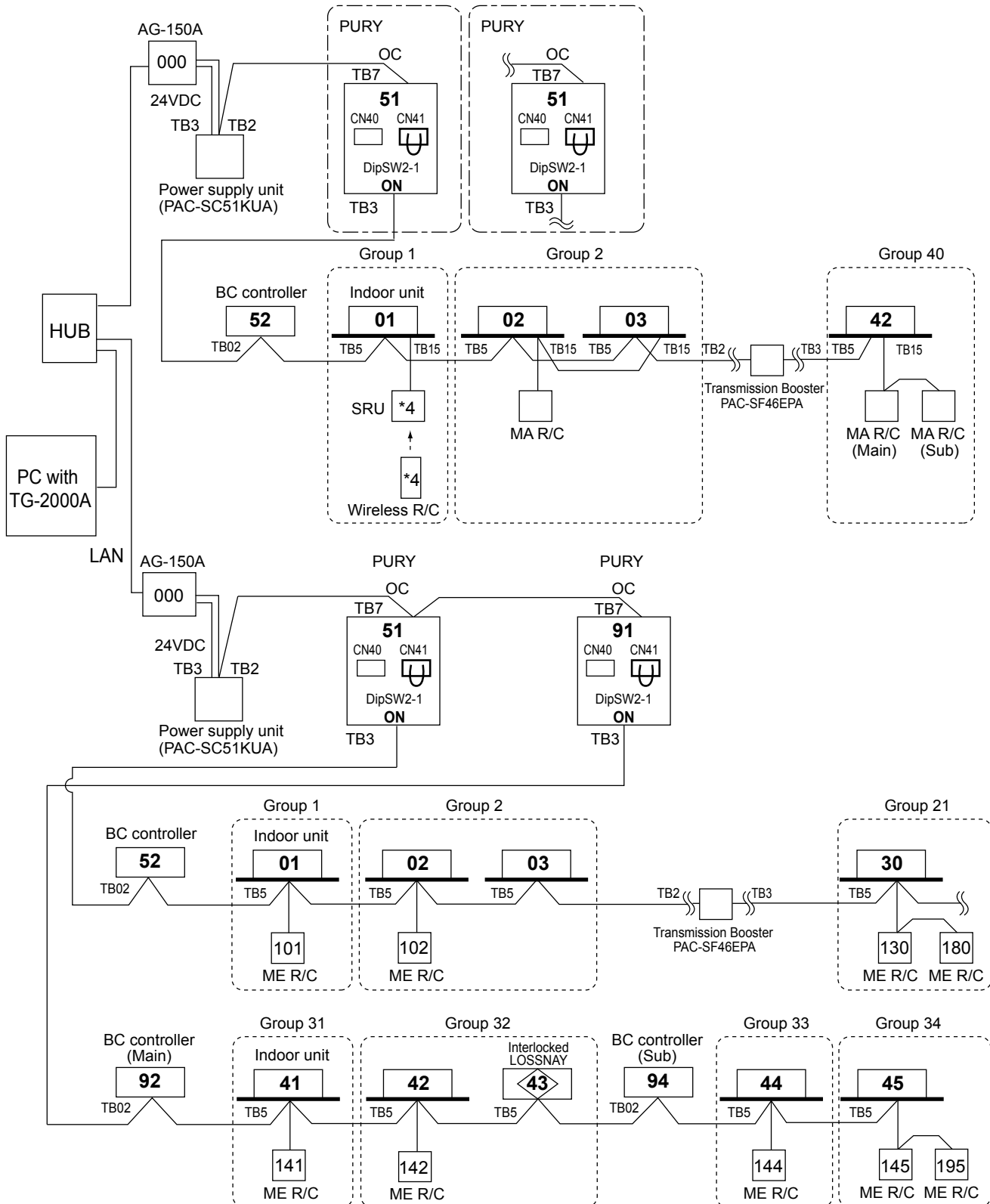

• It is planned that GB-50ADA will be supported on TG-2000A Ver. 6.3* or later.

*1 TG-2000A (Ver.5.5 or later) supports AG-150A (Ver.1series).

TG-2000A (Ver. 6.1 or later) supports AG-150A (Ver. 2.1 or later) connected with the expansion controller (EC).

*2 AG-150A (Ver.1series) does not support the expansion controller (EC).

*3 When AG-150A connected with the expansion controller (EC) is connected, the number of EC will be the maximum controllable number.

TG-2000A can control up to 40 EC or AG-150A without EC connection.

*4 For Wireless R/C and Signal receiver unit (SRU), channel 1, 2 and 3 are selectable and should be set to same channel.

2. M-NET control

2-4-3-11. AG-150A+PAC-YG50ECA (Expansion controller)

AG-150A can control max. 150 indoor units/ via expansion controllers.

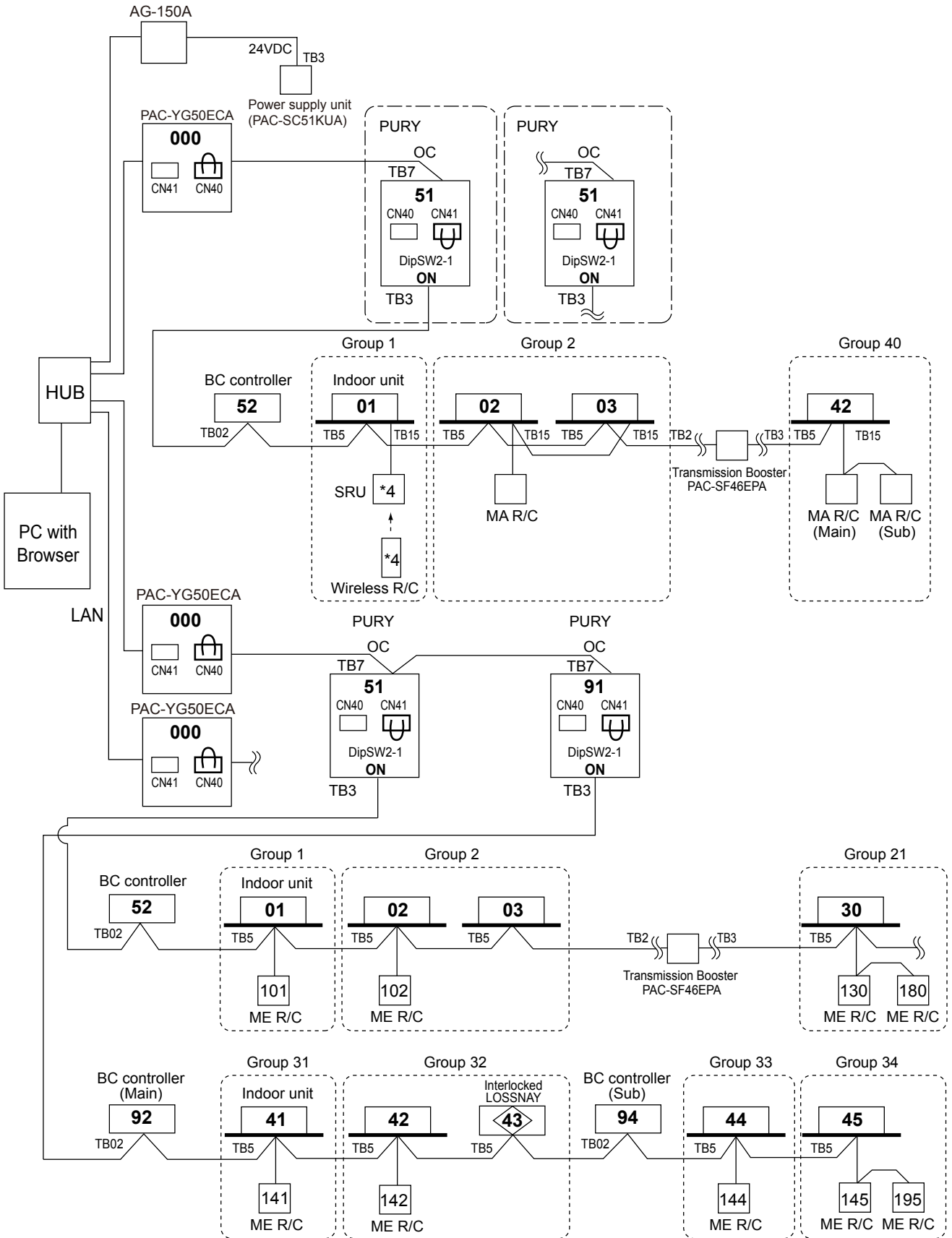

NOTE

- When connecting AG-150A to PAC-YG50ECA, TB2 for power supply unit does not need to be connected to AG-150A.
- *1 For Wireless R/C and Signal receiver unit (SRU), channel 1, 2 and 3 are selectable and should be set to same channel.
- *2 AG-150A (Ver.1series) does not support the expansion controller (EC).

2. M-NET control

2-4-3-12. LMAP

LMAP can transmission for max. 50 indoor units;

If system controller (SC) is used, DipSW1-2 at LMAP and DipSW2-1 at Outdoor unit should set to "ON".

Change Jumper from CN41 to CN40 to activate power supply to LMAP itself for those LMAP connected without system controller (SC).

LMAP can transmission for max. 50 indoor units in single-refrigerant-system or multi-refrigerant-system.

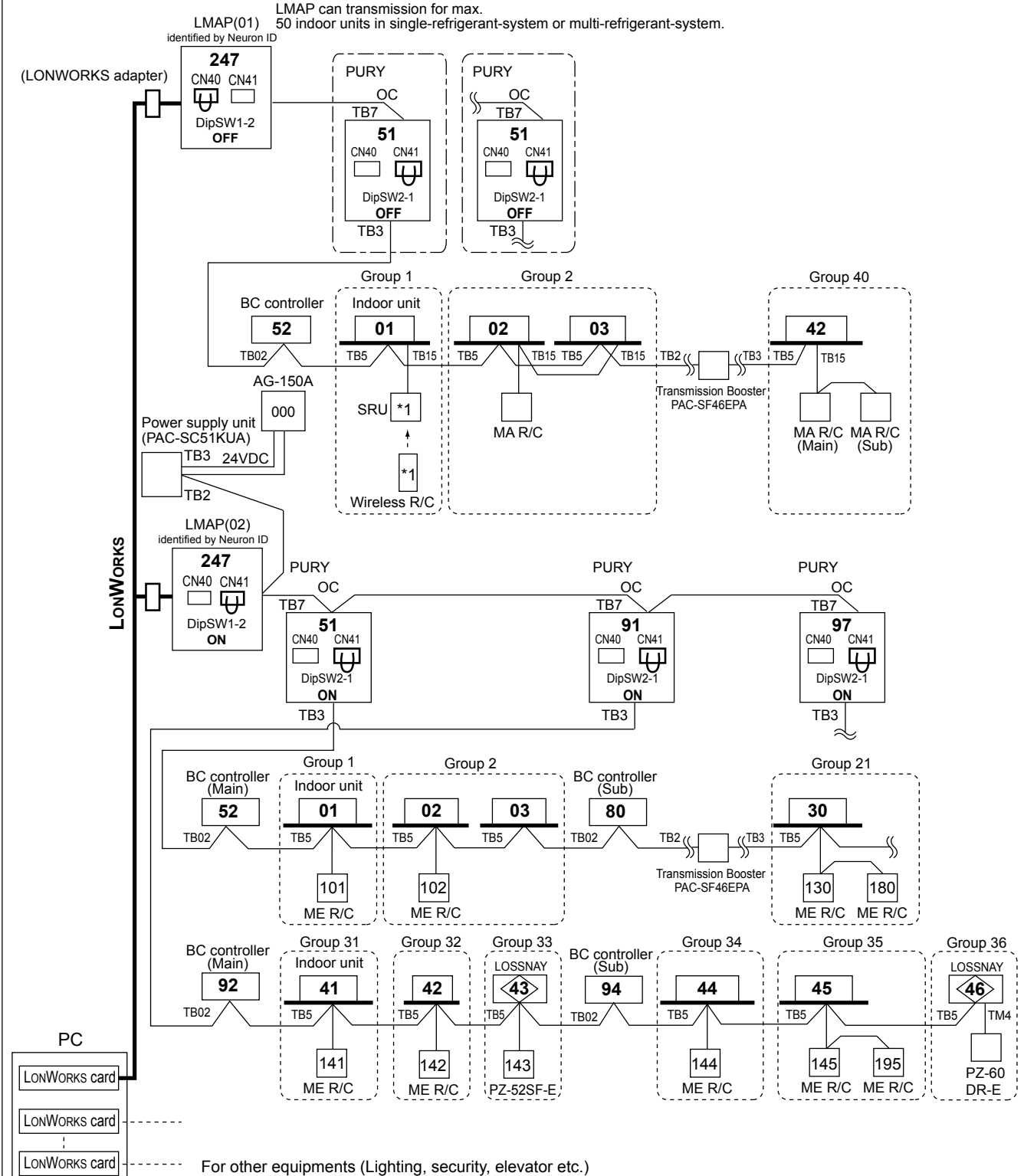

2. M-NET control

2-4-3-13. BM ADAPTER

BM ADAPTER can transmission for max. 50 indoor units;

Change Jumper from CN41 to CN40 to activate power supply to BM ADAPTER itself for those BM ADAPTER connected without the power supply unit.

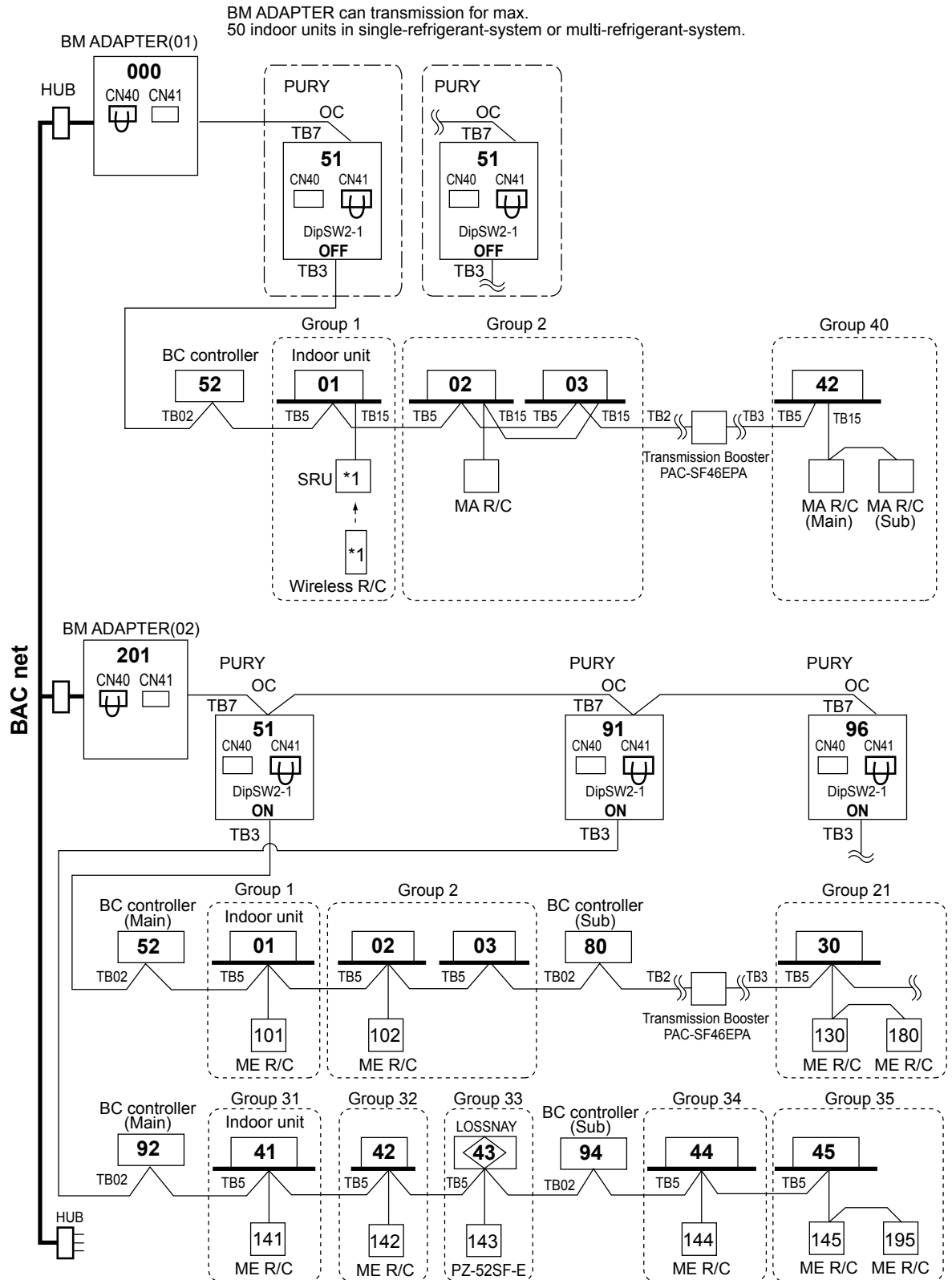

For other equipments (Lighting, security, elevator etc.)

*1 For Wireless R/C and Signal receiver unit (SRU), channel 1, 2 and 3 are selectable and should be set to same channel.

2. M-NET control

2-4-3-14. BM ADAPTER+PAC-YG50ECA (Expansion controller)

BM ADAPTER(*1) can transmission for max. 150 indoor units/via expansion controllers (PAC-YG50ECA).

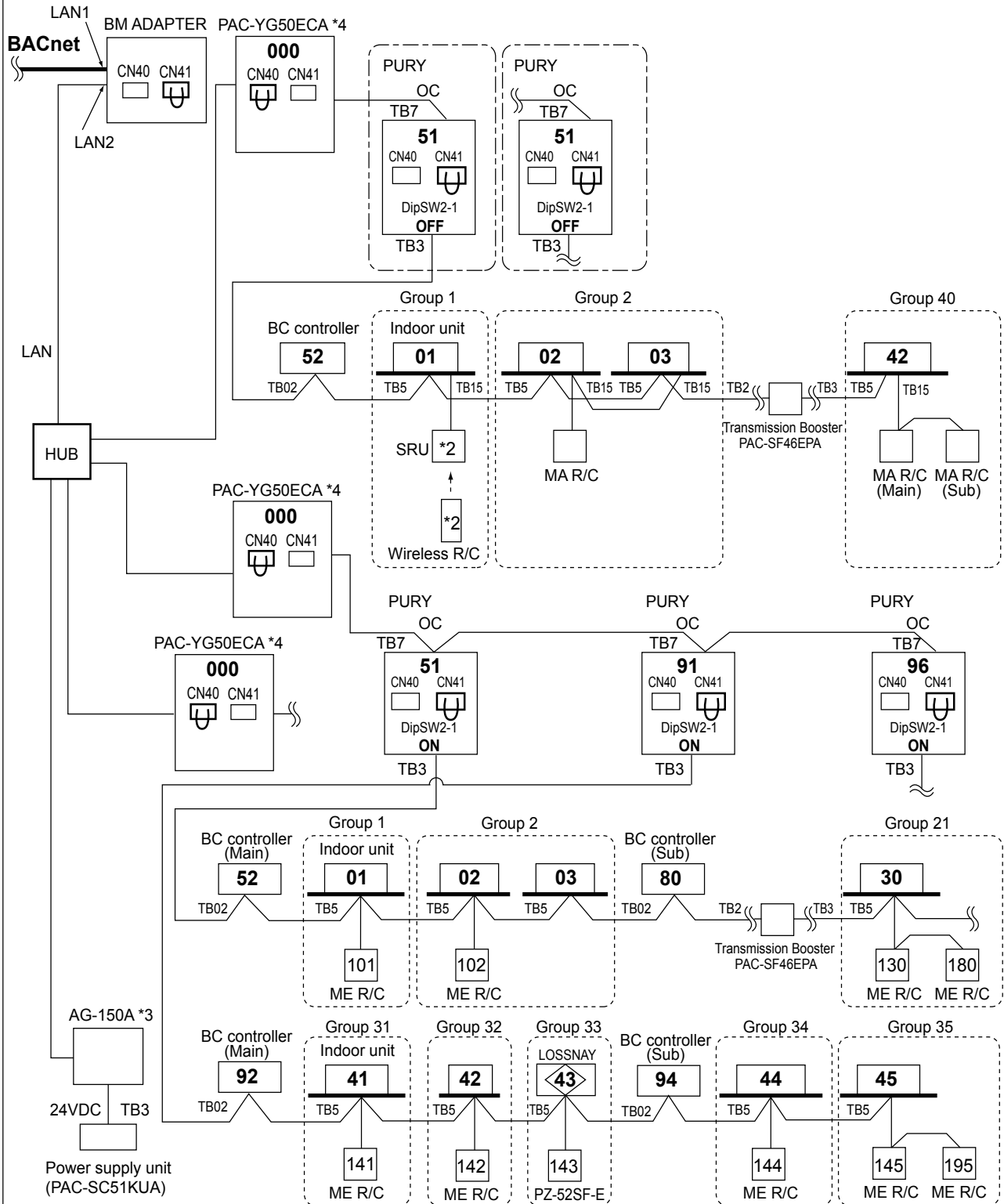

NOTE

•It is not necessary to connect the M-NET transmission line to the TB3 on BM ADAPTER. Leave the power jumper of BM ADAPTER connected to CN41.

*1 BM ADAPTER (Ver.2.00 or later) supports the expansion controller.

*2 For Wireless R/C and Signal receiver unit (SRU), channel 1, 2 and 3 are selectable and should be set to same channel.

*3 AG-150A (Ver.2.30 or later) supports the BM ADAPTER.

*4 PAC-YG50ECA (Ver.1.30 or later) supports the BM ADAPTER.

3. Piping Design

3-1. Piping Design

3-1-1. IF 16 ports or less are in use, i.e., if only one BC controller is in use with no sub BC controller

- Note1. No Header usable on PURY system.
- Note2. Indoor unit sized P100-P250 should be connected to BC controller via Y shape joint CMY-R160-J1 ;
- Note3. Indoor unit sized P100-P250 does NOT share BC controller ports with other Indoor units ;
- Note4. As bents cause pressure loss on transportation of refrigerant, fewer bents design is better ;
Piping length needs to consider the actual length and equivalent length which bents are counted.
Equivalent piping length (m)=Actual piping length+"M" x Quantity of bent.
- Note5. Set DIP-SW 4-6 to ON of BC controller, in case of connected Indoor unit sized P100-P140 with 2 ports.
- Note6. It is also possible to connect Indoor unit sized P100-P140 with 1 port (set DIP-SW 4-6 to OFF).
However, the cooling capacity decreases a little (For details, refer to the chapter OUTDOOR UNITS, R2 SERIES, 6-4. Correction by port counts of the BC controller).
- Note7. Individual indoor units grouped together to connect to the BC controller via one port cannot operate individually in heating and cooling modes at the same time. I.e., they must all function in either heating or cooling together.
- Note8. Indoor capacity is described as its model size. For example, PEFY-P63VML-E, its capacity is P63.
- Note9. Total down-stream Indoor capacity is the summary of the model size of Indoors down-stream.
For example, PEFY-P63VML-E + PEFY-P32VML-E : Total Indoor capacity = P63 + P32 = P95.

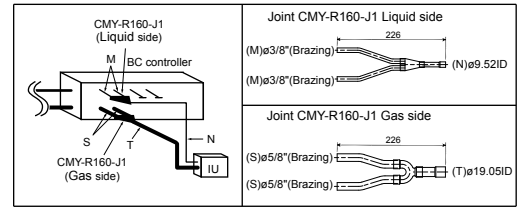

Fig. 3-1-1AA

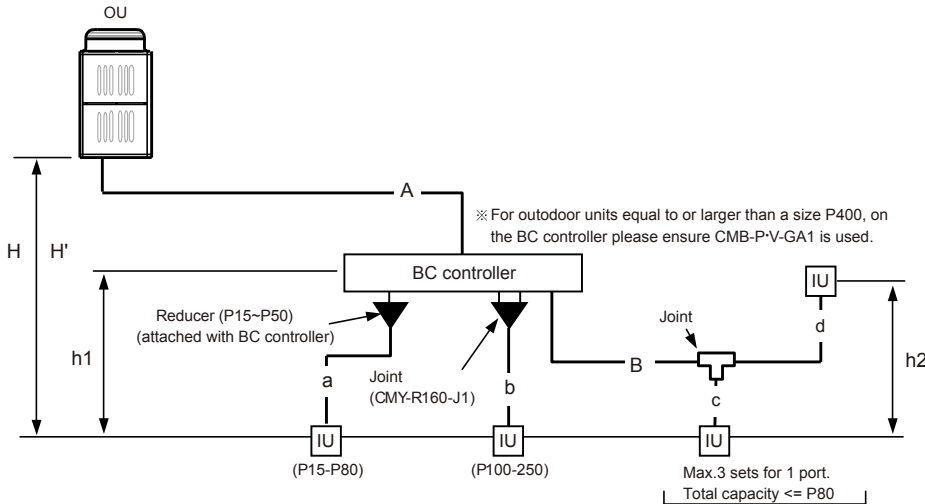

Fig. 3-1-1A Piping scheme

Table 3-1-1-1. Piping length limitation

Item	Piping in the figure	Max. length	Max. equivalent length
Total piping length	A+B+a+b+c+d	220 *1	
Farthest IU from OU	A+B+d	100 (90) *2	125 (115)
Distance between OU and BC	A	70 (60) *2	
Farthest IU from BC controller	B+d	30	
Height between OU and IU (OU above IU)	H	50	
Height between OU and IU (OU under IU)	H'	40	
Height between IU and BC	h1	15 (10) *3	
Height between IU and IU	h2	15 (10) *3	

OU : Outdoor Unit ; IU : Indoor Unit

* 1 Do not exceed the amount of refrigerant to be charged written below.
 $PUR\text{-}RP200\text{-}300YJM\text{-}B : 0.16 \times L_1 + 0.11 \times L_2 + 0.12 \times L_3 + 0.06 \times L_4 + 0.024 \times L_5 < 20$

- L₁: Total length of ø19.05 high pressure pipe (m)
- L₂: Total length of ø15.88 high pressure pipe (m)
- L₃: Total length of ø12.7 liquid pipe (m)
- L₄: Total length of ø9.52 liquid pipe (m)
- L₅: Total length of ø6.35 liquid pipe (m)

* 2 The value in () in the table is applied when indoor total capacity exceeds 130% of outdoor unit capacity.

* 3 Distance of indoor unit size P200, P250 from BC must be less than 10 m, if any.

* 4 ø25.4 for R22

Table3-1-1-2. Bent equivalent length "M"

Outdoor Model	M (m/bent)
PUHY-RP200YJM-B	0.35
PUHY-RP250YJM-B	0.42
PUHY-RP300YJM-B	0.42

Table3-1-1-3. Piping "A" size selection rule

Outdoor Model	Pipe(High pressure)	Pipe(Low pressure)
RP200YJM	ø19.05 [3/4"]	ø28.58 [1-1/8"] *4
RP250YJM	ø19.05 [3/4"]	ø28.58 [1-1/8"]
RP300YJM	ø19.05 [3/4"]	ø28.58 [1-1/8"]

Table3-1-1-4. Piping "B" size selection rule

Total down-stream Indoor capacity	Pipe(Liquid)	Pipe(Gas)
P80 or less	ø9.52 [3/8"]	ø15.88 [5/8"]
P81 or more	ø12.7 [1/2"]	ø19.05 [3/4"]

Table3-1-1-5. Piping "a", "b", "c", "d" size selection rule

Indoor Unit size	Pipe(Liquid)	Pipe(Gas)
P15 to P40, GUF-50RD(H)	ø6.35 [1/4"]	ø12.70 [1/2"]
P50 to P80, GUF-100RD(H)	ø9.52 [3/8"]	ø15.88 [5/8"]
P100 to P140	ø9.52 [3/8"]	ø19.05 [3/4"]
P200	ø12.7 [1/2"]	ø25.4 [1"] or ø28.58 [1-1/8"]
P250	ø12.7 [1/2"]	ø28.58 [1-1/8"]

3. Piping Design

3-1-2. IF more than 16 ports are in use, or if there is more than one BC controller in use for one outdoor unit

- Note1. No Header usable on PURY system.
- Note2. Indoor unit sized P100-P250 should be connected to BC controller via Y shape joint CMY-R160-J1 ;
- Note3. Indoor unit sized P100-P250 does NOT share BC controller ports with other Indoor units ;
- Note4. As bents cause pressure loss on transportation of refrigerant, fewer bents design is better ;
Piping length needs to consider the actual length and equivalent length which bents are counted.
Equivalent piping length (m)=Actual piping length+"M" x Quantity of bent.
- Note5. Set DIP-SW 4-6 to ON of BC controller, in case of connected indoor unit sized P100-P140 with 2 ports.
- Note6. It is also possible to connect Indoor unit sized P100-P140 with 1 port (set DIP-SW 4-6 to OFF).
However, the cooling capacity decreases a little (For details, refer to the chapter OUTDOOR UNITS, R2 SERIES, 6-4. Correction by port counts of the BC controller).
- Note7. Individual indoor units grouped together to connect to the BC controller via one port cannot operate individually in heating and cooling modes at the same time. I.e., they must all function in either heating or cooling together.
- Note8. For sub BC controller CMB-P-V-GB1 the connectable indoor unit capacities may sum to equal that of a P350 unit or less. However, if two sub controllers are used the TOTAL sum of connectable units connected to BOTH sub controllers must also not exceed that of a P350 unit.
For sub BC controller CMB-P1016V-HB1 the connectable indoor unit capacities may sum to equal that of a P350 unit or less. However, if two sub controllers are used the TOTAL sum of connectable units connected to BOTH sub controllers must also not exceed that of a P450 unit.
- Note9. Indoor capacity is described as its model size. For example, PEFY-P63VML-E, its capacity is P63.
Note10. Total down-stream Indoor capacity is the summary of the model size of Indoors down-stream.
For example, PEFY-P63VML-E + PEFY-P32VML-E : Total Indoor capacity = P63 + P32 = P95.

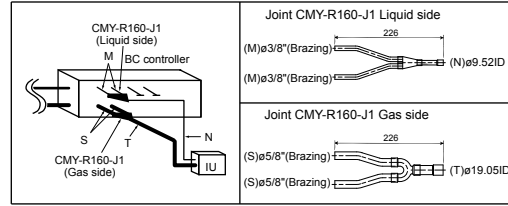

Fig. 3-1-2AA

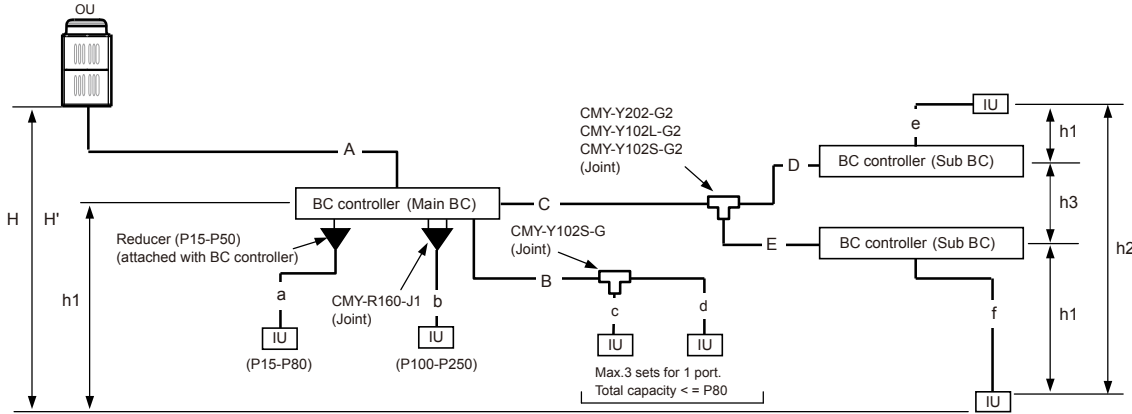

Fig. 3-1-2B Piping scheme

OU : Outdoor unit, IU : Indoor unit

Table 3-1-2-1. Piping length limitation

Item	Piping in the figure	Max. length	Max. equivalent length
Total piping length	A+B+a+b+c+d	220 *1	
Farthest IU from OU	A+B+d	100 (90) *2	125 (115)
Distance between OU and BC	A	70 (60) *2	
Farthest IU from BC controller	B+d	30	
Height between OU and IU (OU above IU)	H	50	
Height between OU and IU (OU under IU)	H'	40	
Height between IU and BC	h1	15 (10) *3	
Height between IU and IU	h2	15 (10) *3	
Height between BC(Main or Sub) and BC(Sub)	h3	15 (10) *3	

OU : Outdoor Unit ; IU : Indoor Unit

* 1 Do not exceed the amount of refrigerant to be charged written below.
 $PUR\text{-}RP200\text{-}300YJM\text{-}B : 0.16 \times L_1 + 0.11 \times L_2 + 0.12 \times L_3 + 0.06 \times L_4 + 0.024 \times L_5 < 20$

- L₁: Total length of ø19.05 high pressure pipe (m)
- L₂: Total length of ø15.88 high pressure pipe (m)
- L₃: Total length of ø12.7 liquid pipe (m)
- L₄: Total length of ø9.52 liquid pipe (m)
- L₅: Total length of ø6.35 liquid pipe (m)

- * 2 The value in () in the table is applied when indoor total capacity exceeds 130% of outdoor unit capacity.
- * 3 Distance of indoor unit size P200, P250 from BC must be less than 10 m, if any.
- * 4 ø25.4 for R22

Table 3-1-2-2. Bent equivalent length "M"

Outdoor Model	M (m/bent)
PUHY-RP200YJM-B	0.35
PUHY-RP250YJM-B	0.42
PUHY-RP300YJM-B	0.42

Table 3-1-2-3. Piping "A" size selection rule (mm [in.])

Outdoor Model	Pipe(High pressure)	Pipe(Low pressure)
RP200YJM	ø19.05 [3/4"]	ø28.58 [1-1/8"] *4
RP250YJM	ø19.05 [3/4"]	ø28.58 [1-1/8"]
RP300YJM	ø19.05 [3/4"]	ø28.58 [1-1/8"]

Table 3-1-2-4. Piping "B" size selection rule (mm [in.])

Total down-stream Indoor capacity	Pipe(Liquid)	Pipe(Gas)
P80 or less	ø9.52 [3/8"]	ø15.88 [5/8"]
P81 or more	ø12.7 [1/2"]	ø19.05 [3/4"]

Table 3-1-2-5. Piping "C", "D", "E" size selection rule (mm [in.])

Total down-stream Indoor capacity	Pipe(Liquid)	Pipe(HP Gas)	Pipe(LP Gas)
P200 or less	ø9.52 [3/8"]	ø15.88 [5/8"]	ø19.05 [3/4"]
P201 to P300	ø9.52 [3/8"]	ø19.05 [3/4"]	ø22.20 [7/8"]
P301 to P350	ø12.70 [1/2"]	ø19.05 [3/4"]	ø28.58 [1-1/8"]
P351 to P400	ø12.70 [1/2"]	ø22.20 [7/8"]	ø28.58 [1-1/8"]

HP : High pressure, LP:Low pressure

Table 3-1-2-6. Piping "a", "b", "c", "d" size selection rule (mm [in.])

Indoor Unit size	Pipe(Liquid)	Pipe(Gas)
P15 to P40, GUF-50RD(H)	ø6.35 [1/4"]	ø12.70 [1/2"]
P50 to P80, GUF-100RD(H)	ø9.52 [3/8"]	ø15.88 [5/8"]
P100 to P140	ø9.52 [3/8"]	ø19.05 [3/4"]
P200	ø12.7 [1/2"]	ø25.4 [1"] or ø28.58 [1-1/8"]
P250	ø12.7 [1/2"]	ø28.58 [1-1/8"]

3. Piping Design

3-1-3. Pipe diameter compatibility table

◎	Standard
●	Usable (Unit performance will be affected.)
○	Usable (Vertical separation between OU and IU to be 20 m or less)
▲	Usable (Piping length limitation will apply.)
△	Usable (Refrigerant charge amount limit will apply.)
×	Not use

(1) Main pipe

Outdoor model		200	250	300
Low pressure	ø15.88	×	×	×
	ø19.05	●	×	×
	ø22.2	●	●	●
	ø25.4	●	●	●
	ø28.58	◎	◎	◎
	ø34.93	×	×	×
High pressure	ø41.28	×	×	×
	ø9.52	×	×	×
	ø12.7	×	×	×
	ø15.88	▲	×	×
	ø19.05	◎	◎	◎

(2) Indoor pipe

Indoor model		15	20	25	32	40	50	63	71	80	100	125
Liquid	ø6.35	◎	◎	◎	◎	◎	▲ (30m or shorter)	▲ (20m or shorter)	×	×	×	×
	ø9.52	△	△	△	△	△	◎	◎	◎	◎	◎	◎
	ø12.7	△	△	△	△	△	△	△	△	△	△	△
	ø19.05	△	△	△	△	△	△	△	△	△	△	△
	ø15.88	○	○	○	○	○	○	◎	◎	◎	◎	◎
Gas	ø12.7	◎	◎	◎	◎	◎	●	×	×	×	×	×
	ø15.88	○	○	○	○	○	◎	◎	◎	◎	◎	◎
	ø19.05	×	×	×	×	×	○	○	○	○	◎	◎
	ø22.2	×	×	×	×	×	×	×	×	×	○	○
	ø25.4	×	×	×	×	×	×	×	×	×	×	×
	ø28.58	×	×	×	×	×	×	×	×	×	×	×

Indoor model		140	200	250
Liquid	ø6.35	×	×	×
	ø9.52	◎	▲ (25m or shorter)	▲ (15m or shorter)
	ø12.7	△	◎	◎
	ø19.05	△	△	△
Gas	ø12.7	×	×	×
	ø15.88	●	×	×
	ø19.05	◎	●	×
	ø22.2	○	●	●
	ø25.4	×	◎	●
	ø28.58	×	○	◎

Note

1) The △ in the table indicates that the existing piping system can be reused if the total amount of refrigerant charge in the existing system is less than the specified amount calculated by using the following formulas:

$$0.16 \times L1 + 0.11 \times L2 + 0.12 \times L3 + 0.06 \times L4 + 0.024 \times L5 < 20$$

L1 : Total length of ø19.05 high pressure pipe(m)

L2 : Total length of ø15.88 high pressure pipe(m)

L3 : Total length of ø12.7 liquid pipe(m)

L4 : Total length of ø9.52 liquid pipe(m)

L5 : Total length of ø6.35 liquid pipe(m)

3. Piping Design

3-1-4. Flow chart to check if the existing piping can be reused

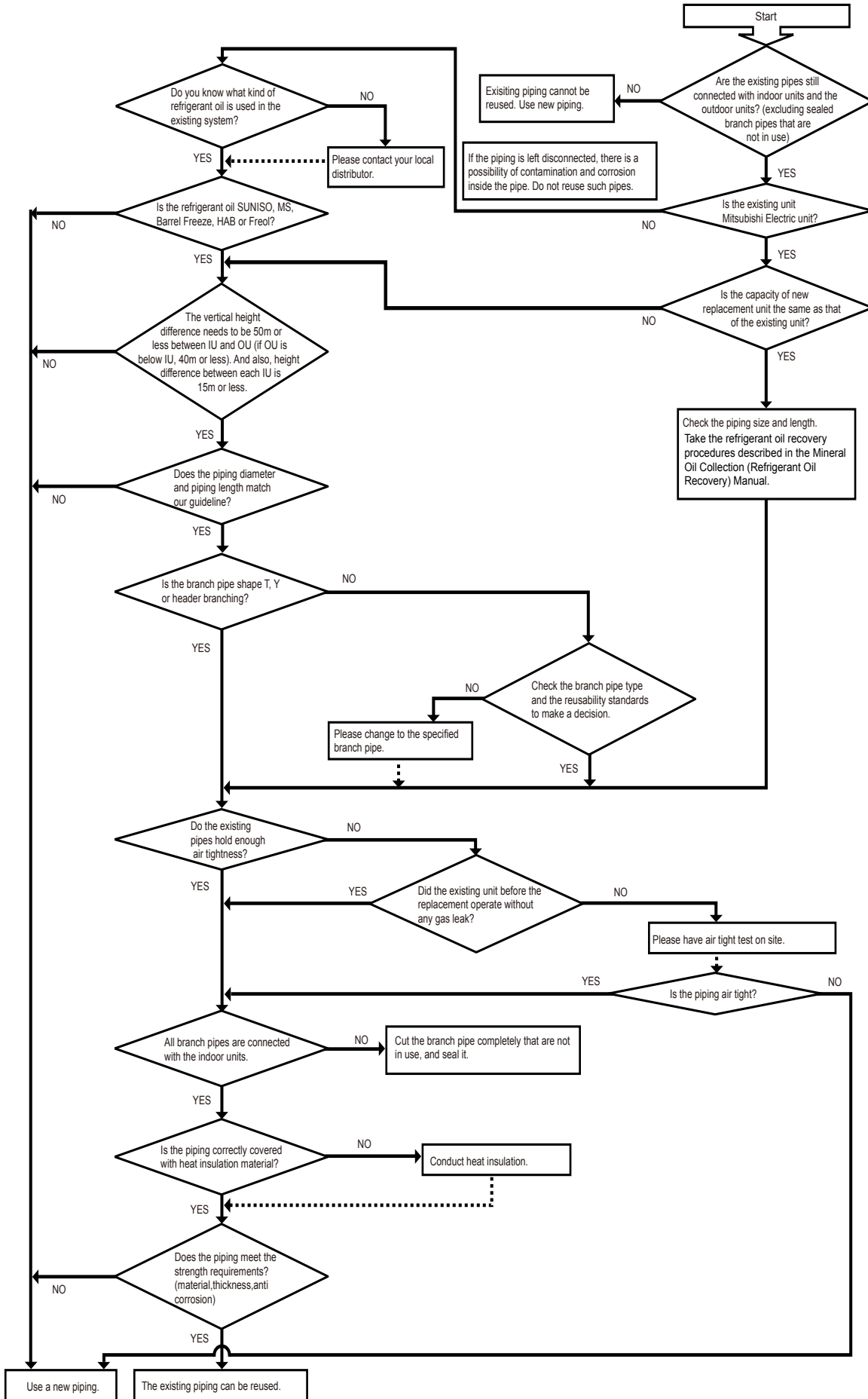

3. Piping Design

3-2. Refrigerant charging calculation

Sample connection (with BC controller and 4 indoor units)

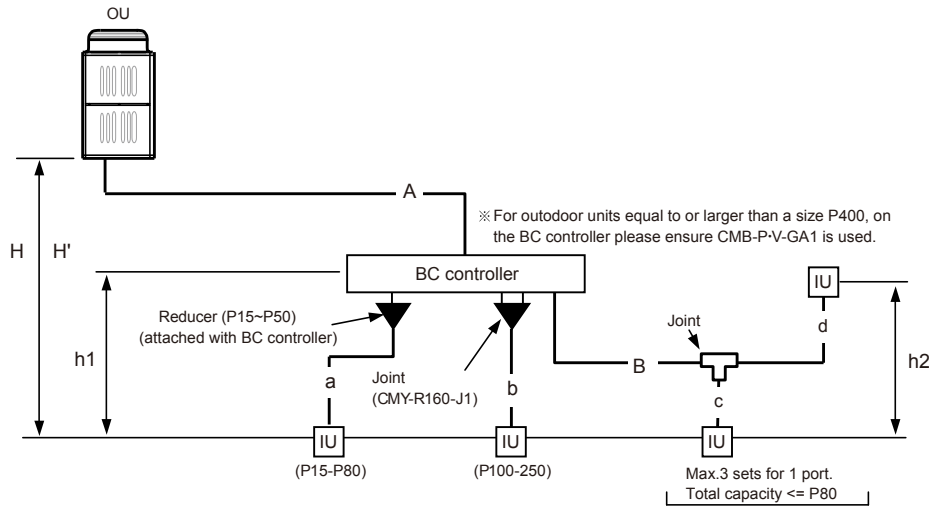

Amount of additional refrigerant to be charged

Refrigerant for extended pipes (field piping) is not factory-charged to the outdoor unit. Add an appropriate amount of refrigerant for each pipes on site. Record the size of each high pressure pipe and liquid pipe, and the amount of refrigerant that was charged on the outdoor unit for future reference.

Calculating the amount of additional refrigerant to be charged

The amount of refrigerant to be charged is calculated with the size of the on-site-installed high pressure pipes and liquid pipes, and their length.

Calculate the amount of refrigerant to be charged according to the formula below.

Round up the calculation result to the nearest 0.1kg. (i.e., 16.08 kg = 16.1 kg)

<Amount of additional refrigerant to be charged>

Calculating the amount of additional refrigerant to be charged

Additional refrigerant charge (kg)	=	High pressure pipe size Total length of ϕ 19.05 \times 0.16 (m) \times 0.16(kg/m)	+	High pressure pipe size Total length of ϕ 15.88 \times 0.11 (m) \times 0.11(kg/m)	+	Liquid pipe size Total length of ϕ 12.7 \times 0.12 (m) \times 0.12(kg/m)	+	Liquid pipe size Total length of ϕ 9.52 \times 0.06 (m) \times 0.06(kg/m)	+	Liquid pipe size Total length of ϕ 6.35 \times 0.024 (m) \times 0.024(kg/m)
	+	Total outdoor unit Model	Charged amount per BC controller (Standard / Main)	+	BC controller (Sub) Total units	Charged amount	+	Total capacity of connected indoor units	Charged amount	
		RP200	2.0 kg		1 unit	1.0 kg		-80	2.0 kg	
		RP250	3.0 kg		2 units	2.0 kg		81 - 160	2.5 kg	
		RP300						161 - 330	3.0 kg	
								331 - 390	3.5 kg	
								391 - 450	4.5 kg	

Amount of factory charged refrigerant

Outdoor unit Model	Charged amount
RP200	11.8 kg
RP250	
RP300	

Sample calculation

Outdoor		Indoor	
A : ϕ 28.58	40m	1 : P80	a : ϕ 9.52 5m
B : ϕ 9.52	10m	2 : P125	b : ϕ 12.7 3m
		3 : P15	c : ϕ 6.35 2m
		4 : P20	d : ϕ 6.35 3m

Total length for each pipe size : ϕ 15.88 A = 40m
 ϕ 12.70 b = 3m
 ϕ 9.52 B + a = 10 + 5 = 15 m
 ϕ 6.35 c + d = 2 + 3 = 5 m

Therefore, additional refrigerant charge = $0.11 \times 40 + 0.12 \times 3 + 0.06 \times 15 + 0.024 \times 5 + 2 + 3$
 = 10.78 kg
 \approx 10.8 kg

4. Outdoor Installation

4-1. Requirement on installation site

1. No direct thermal radiation to the unit.
2. No possibility of annoying the neighbors by the sound of the unit.
Valves and refrigerant flow on the outdoor unit may generate noise.
3. Avoid the sites where strong winds blow.
4. With strength to bear the weight of the unit.
5. Drain flow from the unit is cared at heating mode.
6. Enough space for installation and service as shown at 4-2.
7. Avoid the sites where acidic solutions or chemical sprays (sulfur series) are used frequently.
8. The unit should be secure from combustible gas, oil, steam, chemical gas like acidic solution, sulfur gas and so on.

4. Outdoor Installation

4-2. Spacing

In case of single installation

- Secure enough space around the unit as shown in the figure.

<A> : Top view

Ⓐ : Front

Ⓒ : Back

 : Side view

Ⓑ : Unit height

Ⓓ : Air outlet guide (Procured at the site)

<C> : When there is little space up to an obstruction

(1) If the distance is 300 mm [11-13/16 in.] or more between the rear side and the wall

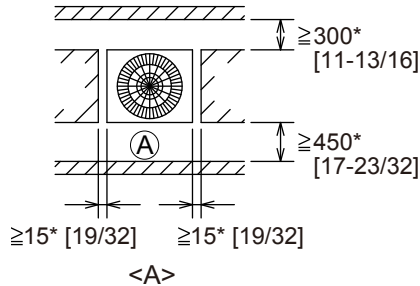

(2) If the distance is 100 mm [3-15/16 in.] or more between the rear side and the wall

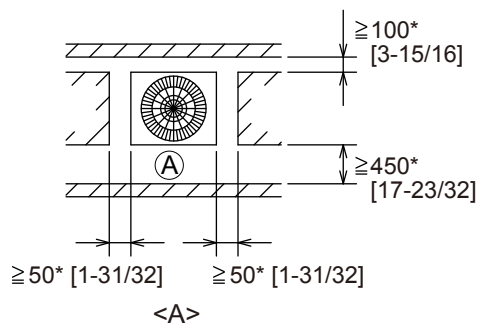

(3) If the wall height (H) of the front, rear or side exceeds the wall height restriction

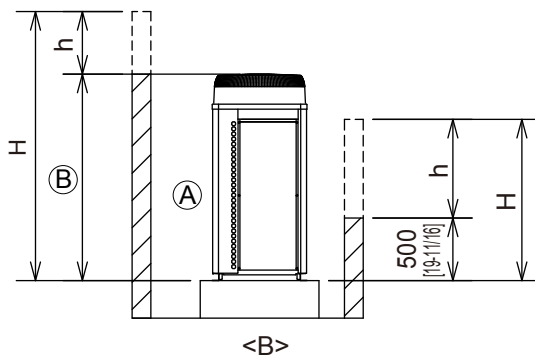

- When the height of the walls on the front, back or on the sides <H> exceeds the wall height limit as defined below, add the height that exceeds the height limit <h> to the figures that are marked with an asterisk.

<Wall height limit> Front: Up to the unit height

Back: Up to 500mm [19-11/16 in.] from the unit bottom

Side: Up to the unit height

If the unit cannot be kept clear of the wall, please change the direction of the air outlet of the unit to blow against the wall to avoid air short cycle.

(4) If there are obstacles at the upper part of the unit

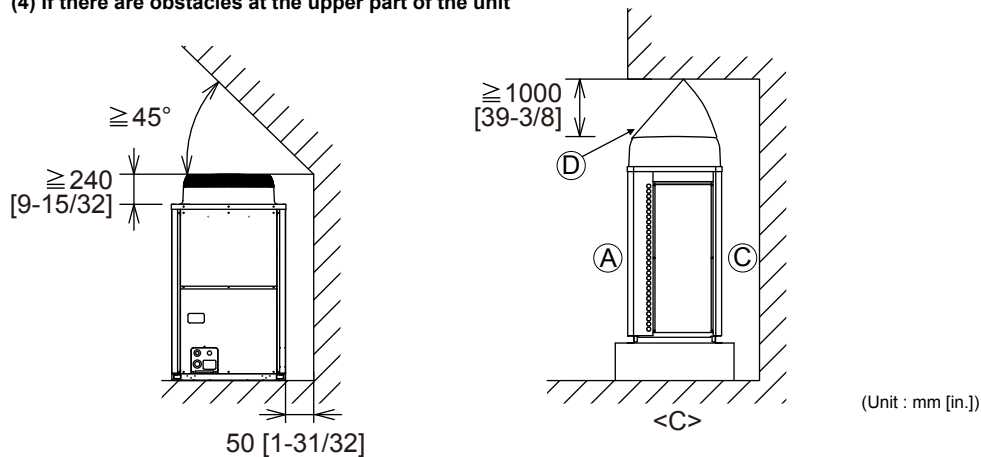

(Unit : mm [in.])

4. Outdoor Installation

In case of collective installation and continuous installation

(A) : Front (C) : Wall height (H)

(B) : Must be open

- When multiple units are installed adjacent to each other, secure enough space to allow for air circulation and passageways between groups of units as shown in the figures.
- At least two sides must be left open.
- As with the single installation, add the height that exceeds the height limit <h> to the figures that are marked with an asterisk.
- If there is a wall at both the front and the rear of the unit, install up to six units consecutively in the side direction and provide a space of 1000mm or more as inlet space/passage space for each six units.

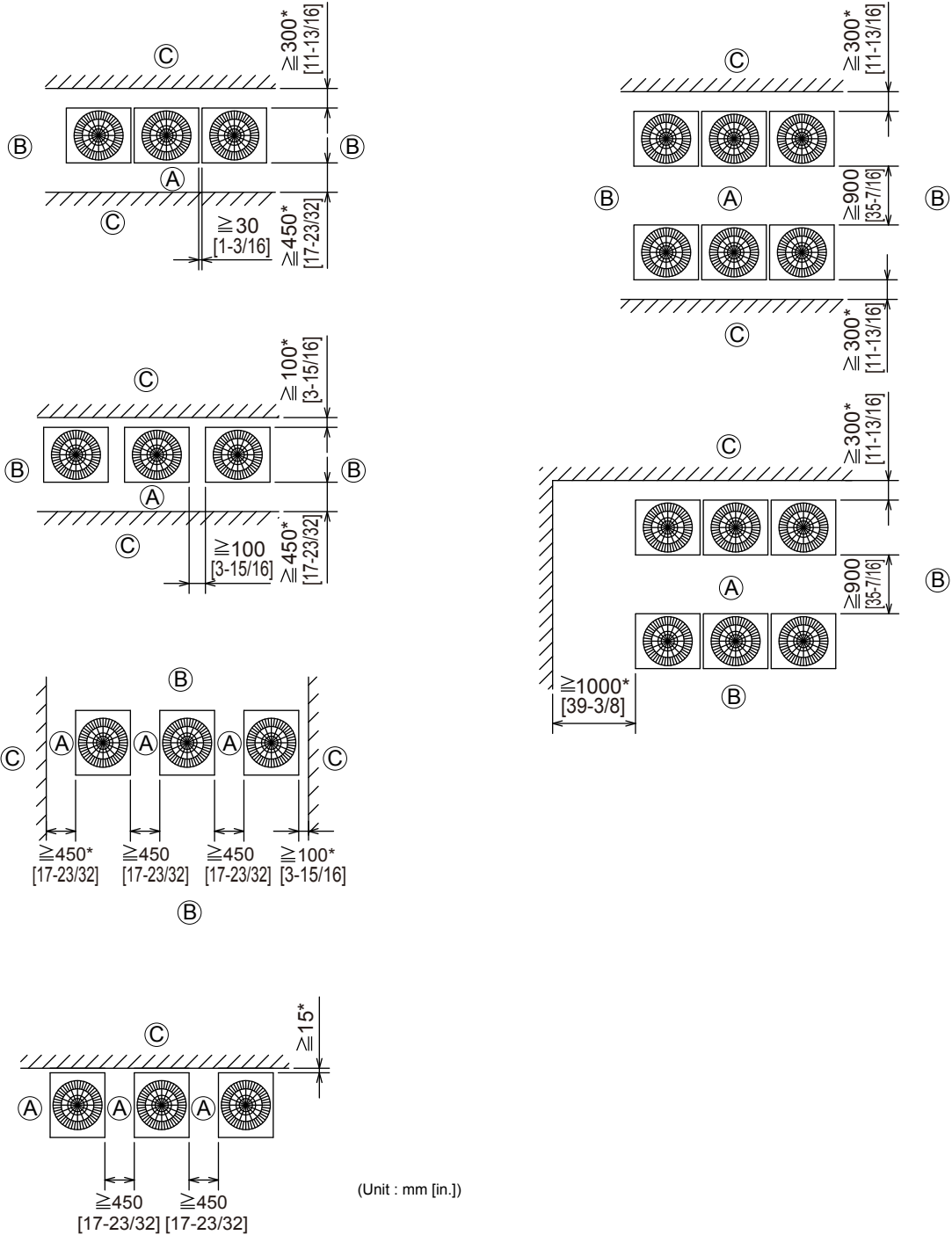

4. Outdoor Installation

4-3. Piping direction

4-3-1. Lifting method

- When lifting the unit with ropes, run the ropes under the unit and use the lifting hole.
- Support the unit at four points with two ropes, and avoid giving mechanical shock.
- Suspension rope angle must be 40° or less, so as to avoid compressing fan guard.
- Use two ropes, each at least 8m [26 ft.] in length
- Use ropes strong enough to support the weight of the unit.
- Always suspend the unit from four corners. (It is dangerous to suspend a unit from two corners and must not be attempted.)
- Use protective pads to keep the ropes from scratching the panels on the unit.

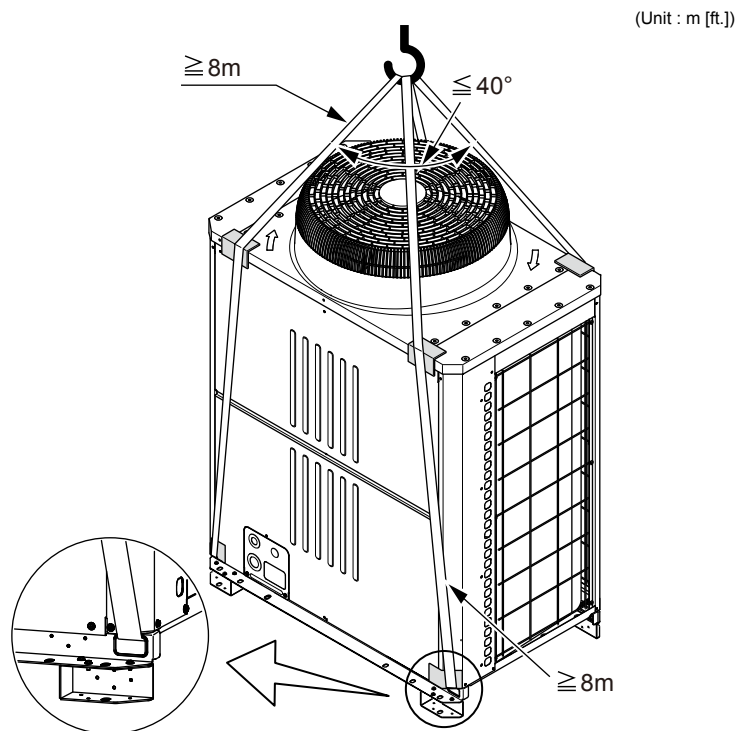

CAUTION

Exercise caution when transporting products.

- Products weighing more than 20 kg [45 LBS] should not be carried alone.
- Do not carry the product by the PP bands.
- To avoid the risk of injury, do not touch the heat exchanger fins.
- Plastic bags may pose a risk of choking hazard to children. Tear plastic bags into pieces before disposing of them.
- When lifting and transporting outdoor units with ropes, run the ropes through lifting hole at the unit base. Securely fix the unit so that the ropes will not slide off, and always lift the unit at four points to prevent the unit from falling.

4. Outdoor Installation

4-3-2. Installation

- Secure the unit with anchor bolts as shown in the figure below so that the unit will not topple over with strong wind or during an earthquake.
- Install the unit on a durable base made of such materials as concrete or angle steel.
- Take appropriate anti-vibration measures (e.g., vibration damper pad, vibration isolation base) to keep vibrations and noise from being transmitted from the unit through walls and floors.
- When using a rubber cushion, install it so that the cushion covers the entire width of the unit leg.
- Install the unit in such a way that the corner of the angle bracket at the base of the unit shown in the figure below is securely supported.
- Install the anchor bolt in such a way that the top end of the anchor bolt do not stick out more than 30 mm [1-3/16 in.].
- This unit is not designed to be anchored with post-installation-type anchor bolts, although by adding fixing brackets anchoring with such type of anchor bolts becomes possible.

- (A) : M10 anchor bolt procured at the site.
- (B) : Corner is not seated.
- (C) : Fixing bracket for hole-in anchor bolt (3 locations to fix with screws).
- (D) : Detachable leg

<Without detachable leg>

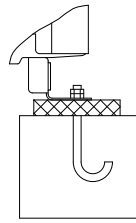
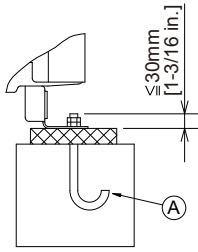

Install the unit in such a way that the corner of the angle bracket at the base of the unit shown in the figure is securely supported. The brackets may bend if they are not securely supported.

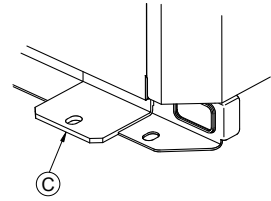
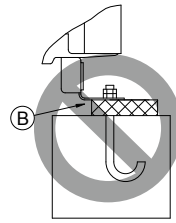

<With detachable leg>

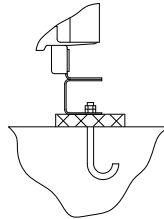
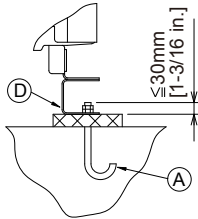

Install the unit in such a way that the corner of the angle bracket at the base of the unit shown in the figure is securely supported. The brackets may bend if they are not securely supported.

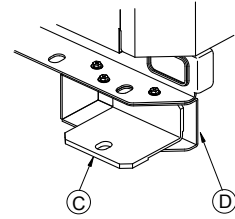
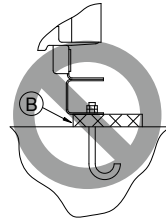

! WARNING
Properly install the unit on a surface that can withstand the weight of the unit. Unit installed on an unstable surface may fall and cause injury.

! WARNING
Take appropriate safety measures against strong winds and earthquakes to prevent the unit from falling.

Take into consideration the durability of the base, water drainage route (Drain water is discharged from outdoor units during operation.), piping route, and wiring route when performing foundation work.

4-3-3. Anchor bolt positions

• Individual installation

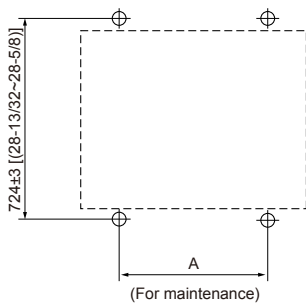

• Collective installation

(Unit : mm [in.])

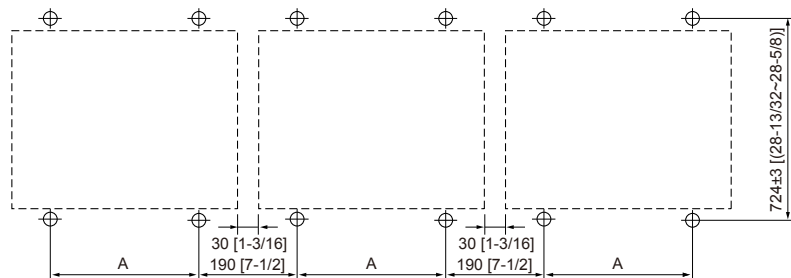

Leave a minimum of 30 mm [1-3/16 in.] between units.

PURY	RP200, 250, 300
A	1060±2 [41-3/4(41-21/32~41-13/16)]

4. Outdoor Installation

4-3-4. Installation

When the pipes and/or cables are routed at the bottom of the unit, make sure that the through hole at the base of the unit does not get blocked with the installation base.

When the pipes are routed at the bottom of the unit, the base should be at least 100 mm [3-15/16 in.] in height.

· RP200, 250, 300

(Unit : mm [in.])

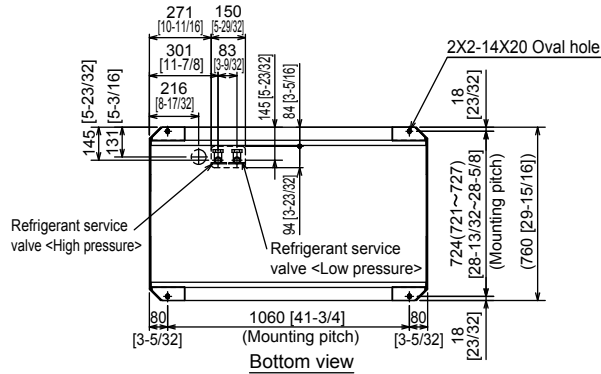

Installation base parallel to the unit's front panel

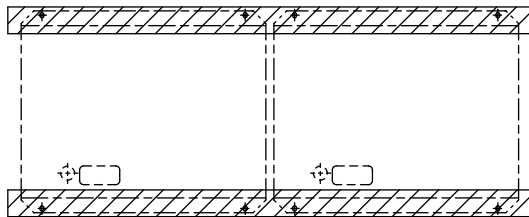

4-3-5. Refrigerant pipe routing

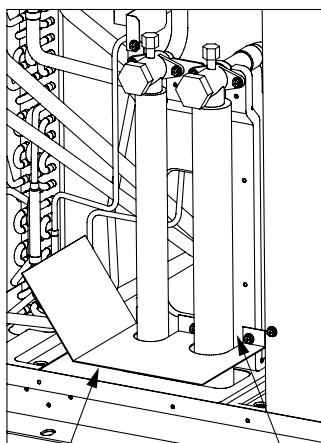

Filler plate
(not supplied)

Fill the gap at the site

The gaps around the edges of through holes for pipes and wires on the unit allow water or mice to enter the unit and damage its parts. Close these gaps with filler plates.

This unit allows two types of pipe routing:

- Bottom piping
- Front piping

⚠ CAUTION

To prevent small animals, water, and snow from entering the unit and damage its parts, close the gap around the edges of through holes for pipes and wires with filler plates.

4. Outdoor Installation

4-4. Weather countermeasure

In cold and/or snowy areas, sufficient countermeasures to wind and snow damages should be taken for operating unit in normal and good condition in winter time. Surround the units with snow nets or fences to protect them from snow. Even in the other areas, full consideration is required for installation of unit in order to prevent abnormal operations caused by wind or snow. **When rain and snow directly fall on unit in the case of air-conditioning operations in 10 or less degrees centigrade outdoor air (50 or less degrees fahrenheit outdoor air), mount inlet and outlet ducts on unit for assuring stable operations.**

Countermeasure to snow and wind

Prevention the Outdoor unit from wind and snow damages in cold or snowy areas, snow hood shown below is recommended and helpful.

- Snow hood

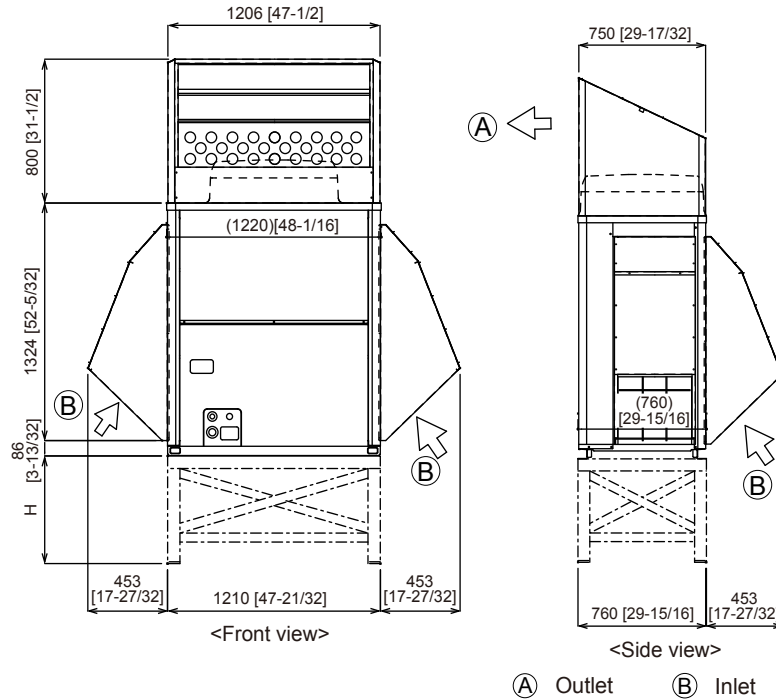

Note:

1. Height of frame base for snow damage prevention (H) shall be twice as high as expected snowfall. Width of frame base shall not exceed that of the unit. The frame base shall be made of angle steel, etc., and designed so that snow and wind slip through the structure. (If frame base is too wide, snow will be accumulated on it.)
2. Install unit so that wind will not directly lash against openings of inlet and outlet ducts.
3. Build frame base at customer referring to this figure.
 Material : Galvanized steel plate 1.2T [1/16 in. T]
 Painting : Overall painting with polyester powder
 Color : Munsell 5Y8/1 (same as that of unit)
4. To install units side by side, install a filler plate between the fan guard and the outlet-side snow hood as shown in Figure A.
 (The filler plate provided accommodates the installation pitch of between 30-80 mm [1-3/16~3-5/32 in.])
5. When the unit is used in a cold region and the heating operation is continuously performed for a long time when the outside air temperature is below freezing, install a heater to the unit base or take other appropriate measures to prevent water from freezing on the base.

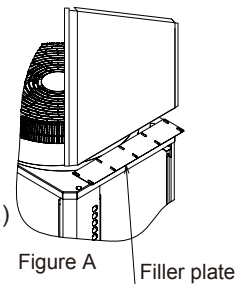

Countermeasure to wind

Referring to the figure shown below, take appropriate measures which will suit the actual situation of the place for installation. A unit installed alone is vulnerable to strong winds. Select the installation site carefully to minimize the effect of winds.

To install a unit in a place where the wind always blows from the same direction, install the unit so that the outlet faces away from the direction of the wind.

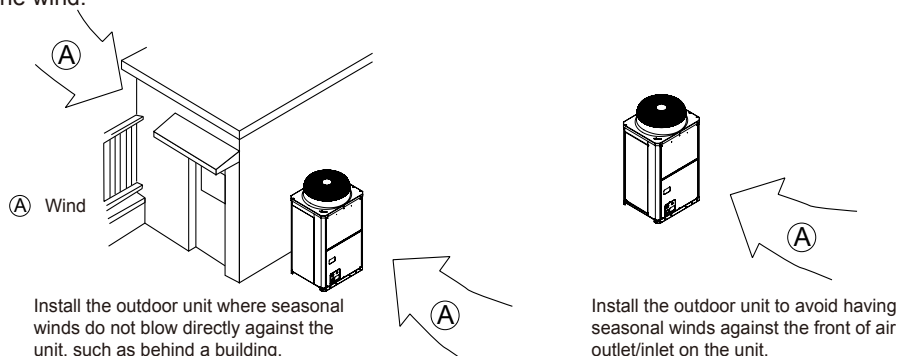

5. Caution for refrigerant leakage

The installer and/or air conditioning system specialist shall secure safety against refrigerant leakage according to local regulations or standards. The following standard may be applicable if no local regulation or standard is available.

5-1. Refrigerant property

R410A refrigerant is harmless and incombustible. The R410A is heavier than the indoor air in density. Leakage of the refrigerant in a room has possibility to lead to a hypoxia situation. Therefore, the Critical concentration specified below shall not be exceeded even if the leakage happens.

• Critical concentration

Critical concentration hereby is the refrigerant concentration in which no human body would be hurt if immediate measures can be taken when refrigerant leakage happens.

Critical concentration of R410A: 0.30kg/m³

(The weight of refrigeration gas per 1 m³ air conditioning space.);

* The Critical concentration is subject to ISO5149, EN378-1.

For the CITY MULTI system, the concentration of refrigerant leaked should not have a chance to exceed the Critical concentration in any situation.

5-2. Confirm the Critical concentration and take countermeasure

The maximum refrigerant leakage concentration (Rmax) is defined as the result of the possible maximum refrigerant weight (Wmax) leaked into a room divided by its room capacity (V). It is referable to Fig.5-1. The refrigerant of Outdoor unit here includes its original charge and additional charge at the site.

The additional charge is calculated according to "3-2 .Refrigerant charging calculation" and shall not be over charged at the site.

Procedure 5-2-1~3 tells how to confirm maximum refrigerant leakage concentration (Rmax) and how to take countermeasures against a possible leakage.

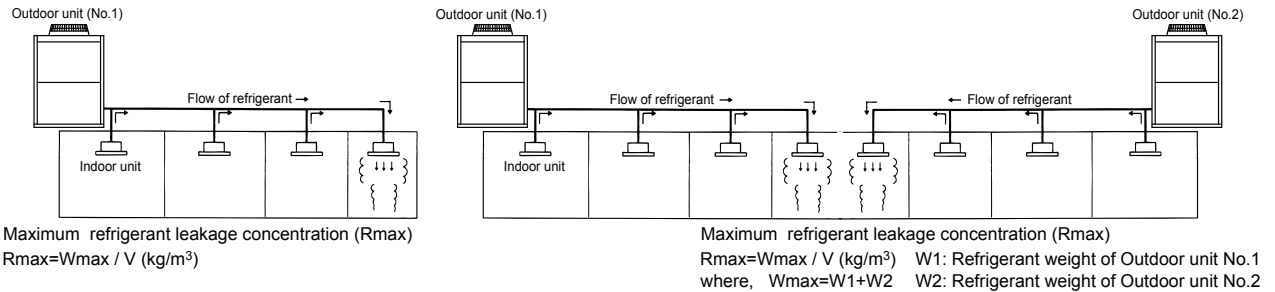

Fig. 5-1 The maximum refrigerant leakage concentration

5-2-1. Find the room capacity (V),

If a room having total opening area more than 0.15% of the floor area at a low position with another room/space, the two rooms/space are considered as one. The total space shall be added up.

5-2-2. Find the possible maximum leakage (Wmax) in the room. If a room has Indoor unit(s) from more than 1 Outdoor unit, add up the refrigerant of the Outdoor units.

5-2-3. Divide (Wmax) by (V) to get the maximum refrigerant leakage concentration (Rmax).

5-2-4. Find if there is any room in which the maximum refrigerant leakage concentration (Rmax) is over 0.30kg/m³.

If no, then the CITY MULTI is safe against refrigerant leakage.

If yes, following countermeasure is recommended to do at site.

Countermeasure 1: Let-out (making V bigger)

Design an opening of more than 0.15% of the floor area at a low position of the wall to let out the refrigerant whenever leaked.

e.g. make the upper and lower seams of door big enough.

Countermeasure 2: Smaller total charge (making Wmax smaller)

e.g. Avoid connecting more than 1 Outdoor unit to one room.

e.g. Using smaller model size but more Outdoor units.

e.g. Shorten the refrigerant piping as much as possible.

Countermeasure 3: Fresh air in from the ceiling (Ventilation)

As the density of the refrigerant is bigger than that of the air. Fresh air supply from the ceiling is better than air exhausting from the ceiling.

Fresh air supply solution refers to Fig.5-2~4.

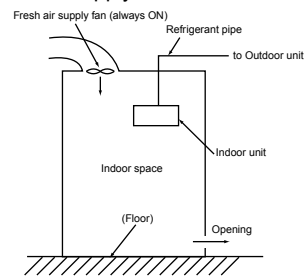

Fig.5-2. Fresh air supply always ON

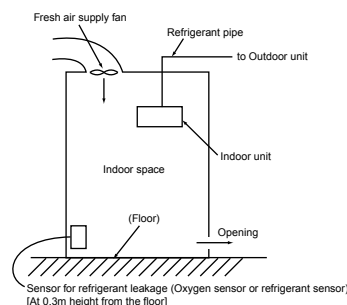

Fig.5-3. Fresh air supply upon sensor action

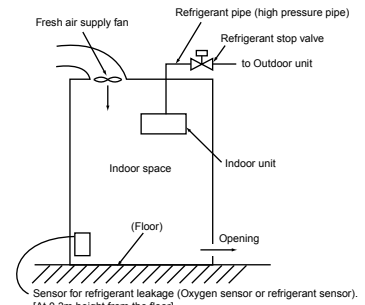

Fig.5-4. Fresh air supply and refrigerant shut-off upon sensor action

Note 1. Countermeasure 3 should be done in a proper way in which the fresh air supply shall be on whenever the leakage happens.

Note 2. In principle, MITSUBISHI ELECTRIC requires proper piping design, installation and air-tight testing after installation to avoid leakage happening.

In the area should earthquake happen, anti-vibration measures should be fully considered.

The piping should consider the extension due to the temperature variation.

CONTROLLER

1-1. System component	286
1-2. Outdoor unit input/output connector	288
1-3. Indoor unit "-E" type input/output connector	289

CONTROLLER

1-1. System component

CITY MULTI system can be monitored or controlled with signal to/from the outside as every control board of Indoor unit or Outdoor unit has input/output signal connectors. Independent control to the individual Indoor or Outdoor can be carried out by using these connectors. Yet, for large-scale control, MELANS would be much easier. When using input/output connectors, a dedicated adapter (optional part) and a relay circuit needed to be prepared by the site. Following are some typical example.

Table 1-1. Control can be achieved by using Outdoor input/output connectors.

Function	Usage	Using connector		Signal	Option
		PUHY	PURY		
Demand	Prohibiting cooling/heating operation (thermo OFF) by an external input to the outdoor unit. * It can be used as the demand control for each refrigerant system.	CN3D	CN3D	Input (level-signal)	Adapter for external input (PAC-SC36NA-E)
Low noise mode	Performs a low noise operation of the outdoor unit by an external input to the outdoor unit. * It can be used as the low noise operation device for each refrigerant system.				
Snow sensor signal input	Forces the outdoor unit to perform a fan operation by receiving signals from the snow sensor. *4	CN3S	CN3S		
Auto-changeover	Cooling/heating operation can be changed by an external input to the outdoor unit.	CN3N	-	Output (level-signal)	Adapter for external output (PAC-SC37SA-E)
Operation status of the compressor	How to extract signals from the outdoor unit. * It can be used as an operation status display device.	CN51	CN51		
Error status	* It can be used for an interlock operation with external devices.				

*1 For details, refer to 1) through 4) shown below.

*2 Low noise mode is valid when Dip SW4-4 on the outdoor unit is set to OFF. When DIP SW4-4 is set to ON, 4 levels of on-DEMAND are possible, using different configurations of low noise mode input and DEMAND input settings.

When 2 or more outdoor units exist in one refrigerant circuit system, 8 levels of on-DEMAND are possible. When 3 outdoor units exist in one refrigerant circuit system, 12 levels of on-DEMAND are possible.

*3 Low noise mode can be switched from ability main to low noise main with Dip SW5-5 on the outdoor unit. Dip SW5-5 OFF: ability main (ability main mode : The sound pressure level is reduced by limiting the maximum fan frequency under the following condition. Cooling mode : outdoor temp. (TH6) < 30°C Heating mode : outdoor temp. (TH6) > 3°C), ON: low noise main.

*4 When multiple outdoor units exist in one refrigerant circuit system, settings on every outdoor unit (signal input) are required.

*5 For detailed drawing, refer to "1-2. Outdoor unit input/output connector".

1) Table 1-1-1 SW4-4: OFF (Compressor ON/OFF, Low noise mode)

CN3D 1-3P	2-level of on-Demand *6
Open	100%(No Demand)
Short-circuit	0%
<hr/>	
CN3D 1-2P	Low noise mode *7
Open	OFF
Short-circuit	ON

*6 When SW4-4 on the outdoor unit in one refrigerant circuit system is set to ON (4 levels or 8 levels or 12 levels of on- DEMAND), this function cannot be used.

*7 This function and the 4 levels or 8 levels on-DEMAND function can be used together. Input the order to CN3D 1-2P on the outdoor unit whose SW4-4 is set to OFF.

2) When SW4-4 on one outdoor unit in one refrigerant circuit system is set to ON (4 levels of on-DEMAND) (*8)

CN3D 1-3P	CN3D 1-2P	
	Open	Short-circuit
Open	100% (No DEMAND)	75%
Short-circuit	0%	50%

Note the following steps to be taken when using STEP DEMAND.

Example: When switching from 100% to 50%

Steps in DEMAND level setting	<WRONG>	100%	→	10%	→	50%
	<CORRECT>	100%	→	75%	→	50%

If the demand settings are switched in the wrong order listed as the wrong example above, the unit may go into thermo OFF mode.

The percentage of the DEMAND listed in the table above is an approximate value based on the compressor volume and does not necessarily correspond with the capacity.

This function and the Low noise mode function cannot be used together.

3) When SW4-4 on the two outdoor units in one refrigerant circuit system is set to ON (8 levels of on-DEMAND) (*8,*9)

8 levels of on-DEMAND		No.2 CN3D					
No.1 CN3D	1-2P	1-3P		Open		Short-circuit	
		Open	Short-circuit	Open	Short-circuit	Open	Short-circuit
Open	Open	Open	100% (No DEMAND)	50%	88%	75%	
	Short-circuit	Short-circuit	50%	0%	38%	25%	
	Short-circuit	Open	88%	38%	75%	63%	
Short-circuit	Open	Short-circuit	75%	25%	63%	50%	
	Short-circuit	Short-circuit					

4) When SW4-4 on the all outdoor units in one refrigerant circuit system is set to ON (12 levels of on-DEMAND) (*9)

12 levels of on-DEMAND		No.2 CN3D								
No.1 CN3D	No.2 CN3D	1-2P		Open				Short-circuit		
		1-3P	Open	Short-circuit	Open	Short-circuit	Open	Short-circuit		
Open	1-2P	1-3P	Open	Open	Short-circuit	Open	Short-circuit	Open	Short-circuit	
			Open	100%	67%	92%	84%	67%	34%	59%
	Short-circuit	Open	67%	34%	59%	50%	34%	0%	25%	17%
		Short-circuit	92%	59%	84%	75%	59%	25%	50%	42%
Short-circuit	1-2P	1-3P	Open	Open	Short-circuit	Open	Short-circuit	Open	Short-circuit	
			Open	84%	50%	75%	67%	50%	17%	42%
	Short-circuit	Open	92%	59%	84%	75%	59%	25%	50%	42%
		Short-circuit	75%	42%	67%	59%	67%	34%	59%	50%

*8 Input the order to CN3D on the outdoor unit whose SW4-4 is set to ON.

*9 CN3D of No. 1, 2, 3 can be selected arbitrary with the outdoor unit whose SW4-4 is set to ON.

CONTROLLER

Table 1-2. Control can be achieved by using Indoor input/output connectors.

Function	Usage	Using connector	Signal
Remote/Local switching *1 ON/OFF *2*3	Indoor group can be controlled ON/OFF by an ON/OFF switching or contact input to the connector of the head Indoor in an Indoor group. It can be interlocked with timer, door, window, or other equipment to "Force stopping"	CN32	Input (level-signal)
ON/OFF *2*3	Indoor group can be controlled ON/OFF by an external pulse signal input to the connector of the head Indoor in an Indoor group.	CN51	Input (pulse-signal)
Demand	Indoor group can be controlled ON/OFF by an ON/OFF switching or contact input to the connector of every Indoor in an Indoor group.	CN52	Input (pulse-signal)
Monitoring ON/OFF state	Signal output from a head Indoor unit, presenting its Indoor group.	CN51	Output
Monitoring heating state	It can be used for monitoring or interlock with other equipment purpose and so on.	CN52	
Monitoring cooling/drying state		CN52	
Monitoring Error state	Signal output from every Indoor unit, for monitoring Error or Thermo-off (fan) state.	CN51	Output
Monitoring Thermo-OFF(fan) state	It can be used for monitoring or interlock with other equipment purpose and so on.	CN52	

*1. When switching to Remote, control at Local remote controller will NOT be effective, but the "CENTRALLY CONTROLLED" is displayed.

*2. MA or ME remote controller is needed for this function.

*3. If using ON/OFF input function, Automatic-address-start-up can not be performed to start-up the system at commissioning.

*4. If CITY MULTI use GB-50A/AG-150A and PLC software to control the Indoor unit via its external input/output connectors, Dip Switch 1-9 and Dip Switch 1-10 should be set to ON.

In this case, the input/output connectors act as normal connectors, functions mentioned at Table 1-2 are no more available.
Details are available at the PLC software Instruction Manual.

Table 1-3. ON/OFF control to each Indoor unit (group) by using Dip Switch 9 and 10 (SW1-9, SW1-10) of the Indoor unit.

Function	Operation on Indoor units	Setting Dip Switch *1*4	
		1-9	1-10
Auto ON	All indoor units will turn ON and automatically resume to its previous mode after 5 minutes from power recovery.	OFF	ON
Auto recovery	Indoor unit recovers to its previous state (ON/OFF, mode) after 5 minutes from power recovery.	ON	OFF
All OFF	Forced stopping regardless of Indoor units' state.	OFF	OFF

*1. The Dip Switch setting should be carried out on every Indoor unit in the group.

*2. Outdoor unit's power supply should NOT be cut. Otherwise, power supply to case heater of the compressor would be cut too, which may cause damage to the compressor.

*3. Above method can not be applied to the power ON/OFF of the drain pump and humidifier equipment.

*4. If CITY MULTI use GB-50A/AG-150A and PLC software to control the Indoor unit via its external input/output connectors, Dip Switch 1-9 and Dip Switch 1-10 should be set to ON.

In this case, the input/output connectors act as normal connectors, functions mentioned at Table 1-3 are no more available.

■ System example

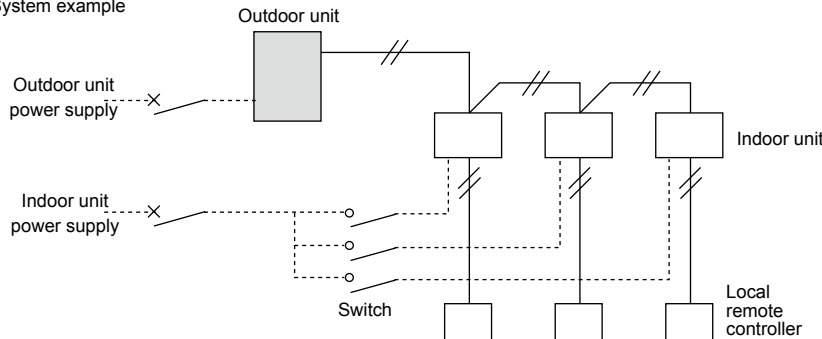

Restart of the CITY MULTI needs to be careful. When no power supply to the outdoor unit, no power supply to the compressor case heater too. The compressor needed to be warmed up before running. When using above functions, power supply to the outdoor unit should be ensured.

Table 1-4. How to use Remote/Local switching connector CN32

State	Local remote controller display and operation	CN32-SW-1 for Local/Remote control switching	CN32-SW-2 for Remote "ON/OFF" operation
Local remote controller control	Operation is permitted	OFF	OFF
Remote STOP	"CENTRALLY CONTROLLED" flashing, "ON/OFF" at local remote controller is not possible.	ON	OFF
Remote START	"CENTRALLY CONTROLLED" flashing, "ON/OFF" at local remote controller is not possible.	ON	ON

* For details refer to CN32 in section "1-3. Indoor unit "-E" type input/output connector".

Table 1-5. Limitations to combining system controls

	Description	Control combining distant/local	Pulse ON/OFF	Power ON/OFF	Automatic recover
1	Control combining distant/local	CN32	-	×*1	×*1
2	Pulse ON/OFF	CN51	-	○	○
3	HA ON/OFF(JEMA)	CN51	-	○	○
4	Power ON/OFF	-	-	-	×
5	Automatic recover	-	-	-	-

*1. Pulse ON/OFF, power ON/OFF and automatic recover can only be used when the remote/local setting CN32 is set to local.
Therefore, always avoid this function when combining control.

CONTROLLER

1-2. Outdoor unit input/output connector

 Caution:	1. Wiring should be covered by insulation tube with supplementary insulation.
	2. Use relays or switches with IEC or equivalent standard.
	3. The electric strength between accessible parts and control circuit should have 2750V or more.

1-2-1. Output

• State (CN51)

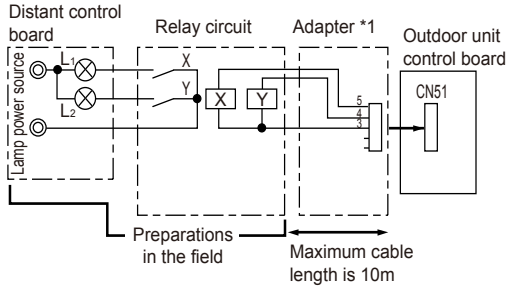

L1 : Outdoor unit error display lamp
 L2 : Compressor operation lamp (compressor running state)
 X, Y : Relay (coil =<0.9W : 12VDC)

*1. Optional part : PAC-SC37SA-E or field supply.

1-2-2. Input

Y, R2 series

(1) Step demand and Low noise mode (CN3D)

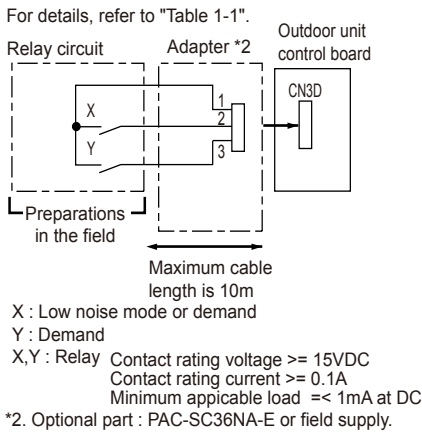

(2) Low noise mode (CN3D + DipSW4-4 OFF)

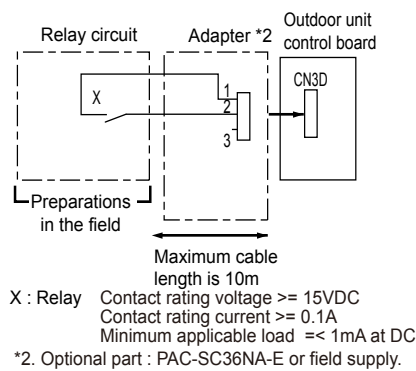

Low noise mode : The sound pressure level is reduced by controlling the maximum fan frequency and compressor frequency.

-Note-
 The sound pressure level can not be reduced, when neither the fan frequency nor the compressor frequency are maximum.

(3) Autochangeover (CN3N) (R2 excluded)

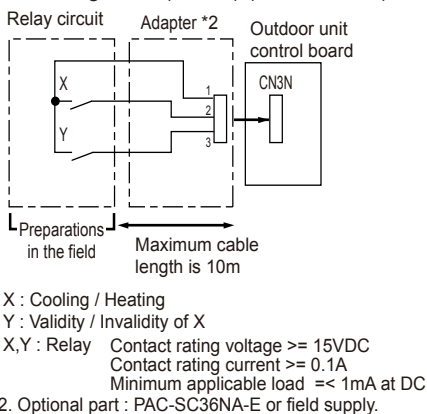

(4) Snow sensor (CN3S)

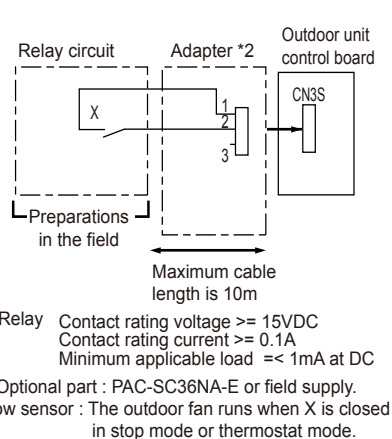

		X	
		OFF	ON
Y	OFF	Normal	
	ON	Cooling	Heating

CONTROLLER

1-3. Indoor unit "-E" type input/output connector

 Caution:	1. Wiring should be covered by insulation tube with supplementary insulation.
	2. Use relays or switches with IEC or equivalent standard.
	3. The electric strength between accessible parts and control circuit should have 2750V or more.

● ON/OFF (Pulse) input specification

Item	Description
Input signal	Pulse sign (a connect)
Standard of pulse	 200msec or more

● Input

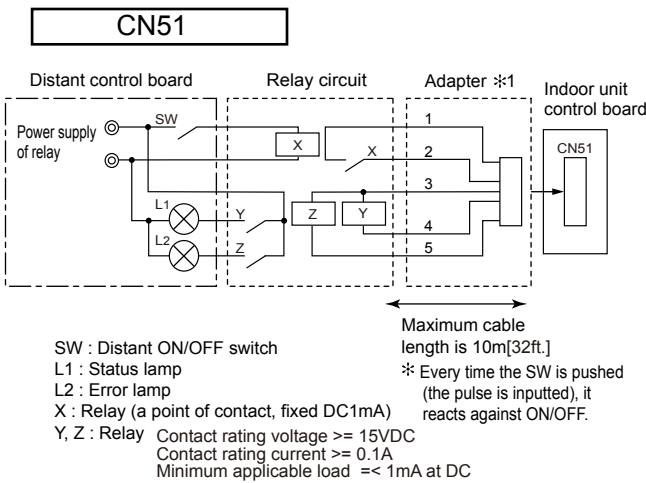

● Output

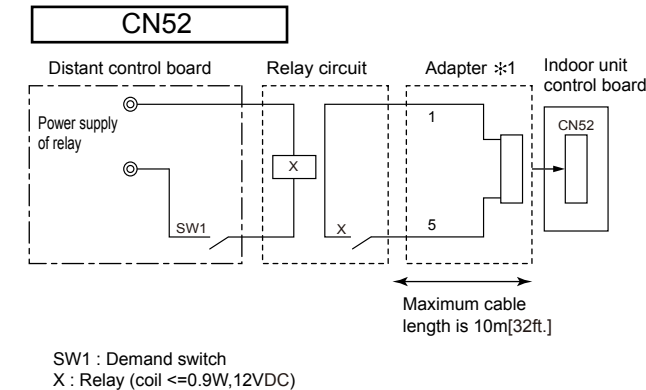
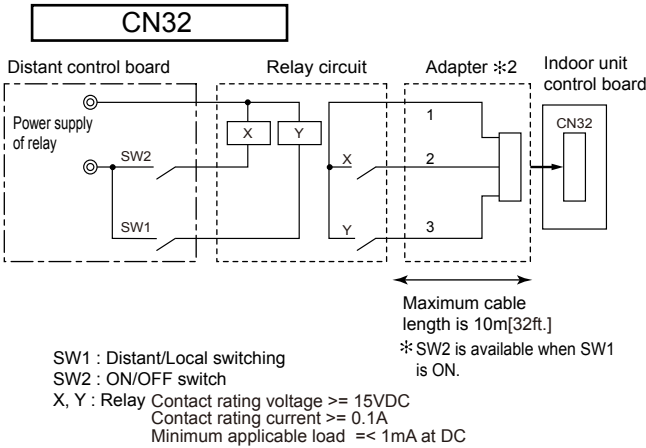
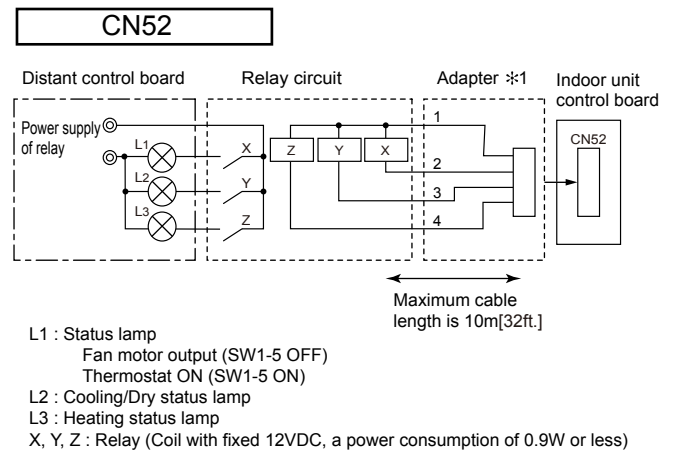

SW1	Indoor unit
ON	Forced thermo-OFF
OFF	Normal running

- * 1. Optional part : PAC-SA88HA-E or field supply
- * 2. Optional part : PAC-SE55RA-E or field supply

DATA BOOK PUHY-RP-Y(S)JM-B
PURY-RP-YJM-B

mitsubishi **ELECTRIC CORPORATION**

HEAD OFFICE: TOKYO BLDG., 2-7-3, MARUNOUCHI, CHIYODA-KU, TOKYO 100-8310, JAPAN