

OUTDOOR UNITS

1. SPECIFICATIONS	2 - 214
2. EXTERNAL DIMENSIONS	2 - 229
3. CENTER OF GRAVITY	2 - 240
4. ELECTRICAL WIRING DIAGRAMS	2 - 241
5. SOUND LEVELS	2 - 243
6. VIBRATION LEVEL	2 - 249
7. OPERATION TEMPERATURE RANGE	2 - 250
8. CAPACITY TABLES	2 - 251
8-1. Selection of Cooling/Heating Units	2 - 252
8-2. Correction by temperature	2 - 254
8-3. Correction by total indoor	2 - 274
8-4. Correction by refrigerant piping length	2 - 283
8-5. Correction by port counts of the BC controller	2 - 286
8-6. Correction at frost and defrost	2 - 286
9. OPTIONAL PARTS	2 - 287
9-1. JOINT	2 - 287
9-2. OUTDOOR TWINNING KIT	2 - 288
9-3. JOINT KIT "CMY-R160-J1" FOR BC CONTROLLER	2 - 290
9-4. RELAY BOX	2 - 291
9-5. BASE HEATER	2 - 292

1. SPECIFICATIONS

YKB/YLM

Model			PURY-P200YLM-A1 (-BS)	PURY-P250YLM-A1 (-BS)	
Power source			3-phase 4-wire 380-400-415 V 50/60 Hz		
Cooling capacity (Nominal)	*1	kW	22.4	28.0	
		kcal/h	20,000	25,000	
		BTU/h	76,400	95,500	
	*1	Power input	kW	5.29	6.98
		Current input	A	8.9-8.4-8.1	11.7-11.1-10.7
		EER	kW/kW	4.23	4.01
Temp. range of cooling	*3	Indoor	W.B.	15.0~24.0°C (59~75°F)	
		Outdoor	D.B.	-5.0~46.0°C (23~115°F)	
Heating capacity (Nominal)	*2	kW	25.0	31.5	
		kcal/h	21,500	27,100	
		BTU/h	85,300	107,500	
	*2	Power input	kW	5.49	7.32
		Current input	A	9.2-8.8-8.4	12.3-11.7-11.3
		COP	kW/kW	4.55	4.30
Temp. range of heating	*3	Indoor	D.B.	15.0~27.0°C (59~81°F)	
		Outdoor	W.B.	-20.0~15.5°C (-4~60°F)	
Indoor unit connectable	Total capacity		50~150%		
	Model/Quantity		P15~P250/1~20		
Sound pressure level (measured in anechoic room)		dB <A>	59	60	
Sound power level (measured in anechoic room)		dB <A>	82.5	83.5	
Refrigerant piping diameter	High pressure		mm (in.)	15.88 (5/8) Brazed	
	Low pressure		mm (in.)	19.05 (3/4) Brazed	
FAN	Type x Quantity		Propeller fan x 1		
	Air flow rate	m ³ /min		185	
		L/s		3,083	
		cfm		6,532	
	Control, Driving mechanism		Inverter-control, Direct-driven by motor		
	Motor output		kW	0.92 x 1	
*4 External static press.		0 Pa (0 mmH ₂ O)			
Compressor	Type x Quantity		Inverter scroll hermetic compressor		
	Manufacture		AC&R Works, MITSUBISHI ELECTRIC CORPORATION		
	Starting method		Inverter		
	Motor output		kW	5.6	
	Case heater		kW	- (- V)	
	Lubricant		MEL32		
External finish			Pre-coated galvanized steel sheets (+powder coating for -BS type) <MUNSELL 5Y 8/1 or similar>		
External dimension H x W x D			mm 1,710 (1,650 without legs) x 920 x 740 in. 67-3/8 (65 without legs) x 36-1/4 x 29-3/16		
Protection devices	High pressure protection		High pressure sensor, High pressure switch at 4.15 MPa (601 psi)		
	Inverter circuit (COMP./FAN)		Over-heat protection, Over-current protection		
	Compressor		Over-heat protection		
	Fan motor		Over-current protection		
Refrigerant	Type x original charge		R410A x 9.5 kg (21 lbs)		
	Control		Indoor LEV and BC controller		
Net weight		kg (lbs)	205 (452)	205 (452)	
Heat exchanger			Salt-resistant cross fin & copper tube		
HIC circuit (HIC: Heat Inter-Changer)			-		
Defrosting method			Auto-defrost mode (Reversed refrigerant cycle, Hot gas)		
Drawing	External		WKJ94T176		
	Wiring		WKE94G041		
Standard attachment	Document		Installation Manual		
	Accessory		Refrigerant conn. pipe		
Optional parts			Joint: CMY-Y102SS-G2,CMY-Y102LS-G2,CMY-R160-J1 BC controller: CMB-P104,105,106,108,1010,1013,1016V-G1 Main BC controller: CMB-P108,1010,1013,1016V-GA1 Sub BC controller: CMB-P104,108V-GB1,CMB-P1016V-HB1		
Remarks			Details on foundation work, duct work, insulation work, electrical wiring, power source switch, and other items shall be referred to the Installation Manual. Due to continuing improvement, above specifications may be subject to change without notice.		

Notes:	Unit converter
1.Nominal cooling conditions (subject to JIS B8615-2) Indoor: 27°C D.B./19°C W.B. (81°F D.B./66°F W.B.), Outdoor: 35°C D.B./24°C W.B. (95°F D.B./75°F W.B.) Pipe length: 7.5 m (24-9/16 ft.), Level difference: 0 m (0 ft.)	BTU/h =kW x 3,412
2.Nominal heating conditions (subject to JIS B8615-2) Indoor: 20°C D.B. (68°F D.B.), Outdoor: 7°C D.B./6°C W.B. (45°F D.B./43°F W.B.) Pipe length: 7.5 m (24-9/16 ft.), Level difference: 0 m (0 ft.)	cfm =m ³ /min x 35.31
3.-5°C D.B. (23°F D.B.)/-6°C W.B. (21°F W.B.) to 21°C D.B. (70°F D.B.)/15.5°C W.B. (60°F W.B.) with cooling/heating mixed operation.	lbs =kg/0.4536
4.External static pressure option is available (30 Pa, 60 Pa/3.1 mmH ₂ O, 6.1 mmH ₂ O).	*Above specification data is subject to rounding variation.

1. SPECIFICATIONS

YKB/YLM

Model		PURY-P300YLM-A1 (-BS)		PURY-P350YLM-A1 (-BS)	
Power source		3-phase 4-wire 380-400-415 V 50/60 Hz		3-phase 4-wire 380-400-415 V 50/60 Hz	
Cooling capacity (Nominal)	*1	kW	33.5	40.0	
		kcal/h	30,000	35,000	
		BTU/h	114,300	136,500	
	Power input	kW	9.10	11.76	
		A	15.3-14.5-14.0	19.8-18.8-18.1	
EER	kW/kW	3.68	3.40		
Temp. range of cooling	*3	Indoor	W.B.	15.0~24.0°C (59~75°F)	15.0~24.0°C (59~75°F)
		Outdoor	D.B.	-5.0~46.0°C (23~115°F)	-5.0~46.0°C (23~115°F)
Heating capacity (Nominal)	*2	kW	37.5	45.0	
		kcal/h	32,300	40,000	
		BTU/h	128,000	153,500	
	Power input	kW	9.37	11.59	
		A	15.8-15.0-14.4	19.5-18.5-17.9	
COP	kW/kW	4.00	3.88		
Temp. range of heating	*3	Indoor	D.B.	15.0~27.0°C (59~81°F)	15.0~27.0°C (59~81°F)
		Outdoor	W.B.	-20.0~15.5°C (-4~60°F)	-20.0~15.5°C (-4~60°F)
Indoor unit connectable	Total capacity		50~150% of outdoor unit capacity	50~150% of outdoor unit capacity	
	Model/Quantity		P15~P250/1~30	P15~P250/1~35	
Sound pressure level (measured in anechoic room)	dB <A>		62.5	62.5	
Sound power level (measured in anechoic room)	dB <A>		86	86	
Refrigerant piping diameter	High pressure	mm (in.)	19.05 (3/4) Brazed	19.05 (3/4) Brazed	
	Low pressure	mm (in.)	22.2 (7/8) Brazed	28.58 (1-1/8) Brazed	
FAN	Type x Quantity		Propeller fan x 1	Propeller fan x 1	
	Air flow rate	m ³ /min	230	230	
		L/s	3,833	3,833	
		cfm	8,121	8,121	
	Control, Driving mechanism		Inverter-control, Direct-driven by motor	Inverter-control, Direct-driven by motor	
	Motor output	kW	0.92 x 1	0.92 x 1	
*4 External static press.		0 Pa (0 mmH ₂ O)	0 Pa (0 mmH ₂ O)		
Compressor	Type x Quantity		Inverter scroll hermetic compressor	Inverter scroll hermetic compressor	
	Manufacture		AC&R Works, MITSUBISHI ELECTRIC CORPORATION	AC&R Works, MITSUBISHI ELECTRIC CORPORATION	
	Starting method		Inverter	Inverter	
	Motor output	kW	8.1	10.5	
	Case heater	kW	- (- V)	- (- V)	
Lubricant		MEL32	MEL32		
External finish		Pre-coated galvanized steel sheets (+powder coating for -BS type) <MUNSELL 5Y 8/1 or similar>		Pre-coated galvanized steel sheets (+powder coating for -BS type) <MUNSELL 5Y 8/1 or similar>	
External dimension H x W x D		mm	1,710 (1,650 without legs) x 1,220 x 740	1,710 (1,650 without legs) x 1,220 x 740	
		in.	67-3/8 (65 without legs) x 48-1/16 x 29-3/16	67-3/8 (65 without legs) x 48-1/16 x 29-3/16	
Protection devices	High pressure protection		High pressure sensor, High pressure switch at 4.15 MPa (601 psi)	High pressure sensor, High pressure switch at 4.15 MPa (601 psi)	
	Inverter circuit (COMP./FAN)		Over-heat protection, Over-current protection	Over-heat protection, Over-current protection	
	Compressor		Over-heat protection	Over-heat protection	
	Fan motor		Over-current protection	Over-current protection	
Refrigerant	Type x original charge		R410A x 10.3 kg (23 lbs)	R410A x 10.3 kg (23 lbs)	
	Control		Indoor LEV and BC controller	Indoor LEV and BC controller	
Net weight	kg (lbs)		248 (547)	248 (547)	
Heat exchanger		Salt-resistant cross fin & copper tube		Salt-resistant cross fin & copper tube	
HIC circuit (HIC: Heat Inter-Changer)		-		-	
Defrosting method		Auto-defrost mode (Reversed refrigerant cycle, Hot gas)		Auto-defrost mode (Reversed refrigerant cycle, Hot gas)	
Drawing	External	WKJ94T177		WKJ94T177	
	Wiring	WKE94G041		WKE94G041	
Standard attachment	Document	Installation Manual		Installation Manual	
	Accessory	Refrigerant conn. pipe		Refrigerant conn. pipe	
Optional parts		Joint: CMY-Y102SS-G2, CMY-Y102LS-G2, CMY-R160-J1 BC controller: CMB-P104, 105, 106, 108, 1010, 1013, 1016V-G1 Main BC controller: CMB-P108, 1010, 1013, 1016V-GA1 Sub BC controller: CMB-P104, 108V-GB1, CMB-P1016V-HB1		Joint: CMY-Y102SS-G2, CMY-Y102LS-G2, CMY-R160-J1 BC controller: CMB-P104, 105, 106, 108, 1010, 1013, 1016V-G1 Main BC controller: CMB-P108, 1010, 1013, 1016V-GA1 Sub BC controller: CMB-P104, 108V-GB1, CMB-P1016V-HB1	
Remarks		Details on foundation work, duct work, insulation work, electrical wiring, power source switch, and other items shall be referred to the Installation Manual. Due to continuing improvement, above specifications may be subject to change without notice.			

Notes:	Unit converter
1. Nominal cooling conditions (subject to JIS B8615-2) Indoor: 27°C D.B./19°C W.B. (81°F D.B./66°F W.B.), Outdoor: 35°C D.B./24°C W.B. (95°F D.B./75°F W.B.) Pipe length: 7.5 m (24-9/16 ft.), Level difference: 0 m (0 ft.)	BTU/h = kW x 3,412
2. Nominal heating conditions (subject to JIS B8615-2) Indoor: 20°C D.B. (68°F D.B.), Outdoor: 7°C D.B./6°C W.B. (45°F D.B./43°F W.B.) Pipe length: 7.5 m (24-9/16 ft.), Level difference: 0 m (0 ft.)	cfm = m ³ /min x 35.31
3. -5°C D.B. (23°F D.B.)/-6°C W.B. (21°F W.B.) to 21°C D.B. (70°F D.B.)/15.5°C W.B. (60°F W.B.) with cooling/heating mixed operation.	lbs = kg/0.4536
4. External static pressure option is available (30 Pa, 60 Pa/3.1 mmH ₂ O, 6.1 mmH ₂ O).	*Above specification data is subject to rounding variation.

1. SPECIFICATIONS

YKB/YLM

Model			PURY-P400YLM-A1 (-BS)	PURY-P450YLM-A1 (-BS)	
Power source			3-phase 4-wire 380-400-415 V 50/60 Hz		
Cooling capacity (Nominal)	*1	kW	45.0	50.0	
		kcal/h	40,000	45,000	
		BTU/h	153,500	170,600	
	*1	Power input	kW	13.71	14.32
		Current input	A	23.1-21.9-21.1	24.1-22.9-22.1
		EER	kW/kW	3.28	3.49
Temp. range of cooling	*3	Indoor	W.B.	15.0~24.0°C (59~75°F)	
		Outdoor	D.B.	-5.0~46.0°C (23~115°F)	
Heating capacity (Nominal)	*2	kW	45.0	56.0	
		kcal/h	40,000	50,000	
		BTU/h	153,500	191,100	
	*2	Power input	kW	11.42	14.93
		Current input	A	19.2-18.3-17.6	25.2-23.9-23.0
		COP	kW/kW	3.94	3.75
Temp. range of heating	*3	Indoor	D.B.	15.0~27.0°C (59~81°F)	
		Outdoor	W.B.	-20.0~15.5°C (-4~60°F)	
Indoor unit connectable	Total capacity		50~150% of outdoor unit capacity		
	Model/Quantity		P15~P250/1~40		
Sound pressure level (measured in anechoic room)		dB <A>	62.5	62.5	
Sound power level (measured in anechoic room)		dB <A>	86	86	
Refrigerant piping diameter	High pressure	mm (in.)	22.2 (7/8) Brazed	22.2 (7/8) Brazed	
	Low pressure	mm (in.)	28.58 (1-1/8) Brazed	28.58 (1-1/8) Brazed	
FAN	Type x Quantity		Propeller fan x 1		
	Air flow rate	m ³ /min	230	320	
		L/s	3,833	5,333	
		cfm	8,121	11,299	
	Control, Driving mechanism		Inverter-control, Direct-driven by motor		
	Motor output	kW	0.92 x 1	0.92 x 2	
*4 External static press.		0 Pa (0 mmH ₂ O)			
Compressor	Type x Quantity		Inverter scroll hermetic compressor		
	Manufacture		AC&R Works, MITSUBISHI ELECTRIC CORPORATION		
	Starting method		Inverter		
	Motor output	kW	10.9	12.4	
	Case heater	kW	- (- V)	- (- V)	
	Lubricant		MEL32		
External finish		Pre-coated galvanized steel sheets (+powder coating for -BS type) <MUNSELL 5Y 8/1 or similar>			
External dimension H x W x D	mm		1,710 (1,650 without legs) x 1,220 x 740		
	in.		67-3/8 (65 without legs) x 48-1/16 x 29-3/16		
Protection devices	High pressure protection		High pressure sensor, High pressure switch at 4.15 MPa (601 psi)		
	Inverter circuit (COMP./FAN)		Over-heat protection, Over-current protection		
	Compressor		Over-heat protection		
	Fan motor		Over-current protection		
Refrigerant	Type x original charge		R410A x 10.3 kg (23 lbs)		
	Control		Indoor LEV and BC controller		
Net weight	kg (lbs)		246 (543)	321 (708)	
Heat exchanger		Salt-resistant cross fin & copper tube			
HIC circuit (HIC: Heat Inter-Changer)		-			
Defrosting method		Auto-defrost mode (Reversed refrigerant cycle, Hot gas)			
Drawing	External	WKJ94T177			
	Wiring	WKE94G041			
Standard attachment	Document	Installation Manual			
	Accessory	Refrigerant conn. pipe			
Optional parts	Joint: CMY-Y102SS-G2,CMY-Y102LS-G2,CMY-R160-J1		Joint: CMY-Y102SS-G2,CMY-Y102LS-G2,CMY-R160-J1		
	Main BC controller: CMB-P108,1010,1013,1016V-GA1 Sub BC controller: CMB-P104,108V-GB1,CMB-P1016V-HB1		Main BC controller: CMB-P108,1010,1013,1016V-GA1 Sub BC controller: CMB-P104,108V-GB1,CMB-P1016V-HB1		
Remarks		Details on foundation work, duct work, insulation work, electrical wiring, power source switch, and other items shall be referred to the Installation Manual. Due to continuing improvement, above specifications may be subject to change without notice.			

Notes:	Unit converter
1.Nominal cooling conditions (subject to JIS B8615-2) Indoor: 27°C.D.B./19°C.W.B. (81°F.D.B./66°F.W.B.), Outdoor: 35°C.D.B./24°C.W.B. (95°F.D.B./75°F.W.B.) Pipe length: 7.5 m (24-9/16 ft.), Level difference: 0 m (0 ft.)	BTU/h =kW x 3,412
2.Nominal heating conditions (subject to JIS B8615-2) Indoor: 20°C.D.B. (68°F.D.B.), Outdoor: 7°C.D.B./6°C.W.B. (45°F.D.B./43°F.W.B.) Pipe length: 7.5 m (24-9/16 ft.), Level difference: 0 m (0 ft.)	cfm =m ³ /min x 35.31
3.-5°C.D.B. (23°F.D.B.)/-6°C.W.B. (21°F.W.B.) to 21°C.D.B. (70°F.D.B.)/15.5°C.W.B. (60°F.W.B.) with cooling/heating mixed operation.	lbs =kg/0.4536
4.External static pressure option is available (30 Pa, 60 Pa/3.1 mmH ₂ O, 6.1 mmH ₂ O).	*Above specification data is subject to rounding variation.

1. SPECIFICATIONS

YKB/YLM

R2

Model		PURY-P500YLM-A1 (-BS)		
Power source		3-phase 4-wire 380-400-415 V 50/60 Hz		
Cooling capacity (Nominal)	*1	kW	56.0	
		kcal/h	50,000	
	*1	BTU/h	191,100	
		Power input	kW	17.77
		Current input	A	29.9-28.4-27.4
	EER	kW/kW	3.15	
Temp. range of cooling	*3	Indoor	W.B.	15.0~24.0°C (59~75°F)
		Outdoor	D.B.	-5.0~46.0°C (23~115°F)
Heating capacity (Nominal)	*2	kW	58.0	
		kcal/h	50,000	
	*2	BTU/h	197,900	
		Power input	kW	16.06
		Current input	A	27.1-25.7-24.8
	COP	kW/kW	3.61	
Temp. range of heating	*3	Indoor	D.B.	15.0~27.0°C (59~81°F)
		Outdoor	W.B.	-20.0~15.5°C (-4~60°F)
Indoor unit connectable	Total capacity		50~150% of outdoor unit capacity	
	Model/Quantity		P15~P250/1~50	
Sound pressure level (measured in anechoic room)		dB <A>	63.5	
Sound power level (measured in anechoic room)		dB <A>	87	
Refrigerant piping diameter	High pressure		mm (in.)	22.2 (7/8) Brazed
	Low pressure		mm (in.)	28.58 (1-1/8) Brazed
FAN	Type x Quantity		Propeller fan x 2	
	Air flow rate	m ³ /min	380	
		L/s	6,333	
		cfm	13,418	
	Control, Driving mechanism		Inverter-control, Direct-driven by motor	
*4	Motor output	kW	0.92 x 2	
External static press.		0 Pa (0 mmH ₂ O)		
Compressor	Type x Quantity		Inverter scroll hermetic compressor	
	Manufacture		AC&R Works, MITSUBISHI ELECTRIC CORPORATION	
	Starting method		Inverter	
	Motor output	kW	13.4	
	Case heater	kW	- (- V)	
Lubricant		MEL32		
External finish		Pre-coated galvanized steel sheets (+powder coating for -BS type) <MUNSELL 5Y 8/1 or similar>		
External dimension H x W x D		mm	1,710 (1,650 without legs) x 1,750 x 740	
		in.	67-3/8 (65 without legs) x 68-15/16 x 29-3/16	
Protection devices	High pressure protection		High pressure sensor, High pressure switch at 4.15 MPa (601 psi)	
	Inverter circuit (COMP./FAN)		Over-heat protection, Over-current protection	
	Compressor		Over-heat protection	
	Fan motor		Over-current protection	
Refrigerant	Type x original charge		R410A x 11.8 kg (27 lbs)	
	Control		Indoor LEV and BC controller	
Net weight		kg (lbs)	321 (708)	
Heat exchanger		Salt-resistant cross fin & copper tube		
HIC circuit (HIC: Heat Inter-Changer)		-		
Defrosting method		Auto-defrost mode (Reversed refrigerant cycle, Hot gas)		
Drawing	External		WKJ94T178	
	Wiring		WKE94G042	
Standard attachment	Document		Installation Manual	
	Accessory		Refrigerant conn. pipe	
Optional parts		Joint: CMY-Y102SS-G2, CMY-Y102LS-G2, CMY-R160-J1 Main BC controller: CMB-P108, 1010, 1013, 1016V-GA1 Sub BC controller: CMB-P104, 108V-GB1, CMB-P1016V-HB1		
Remarks		Details on foundation work, duct work, insulation work, electrical wiring, power source switch, and other items shall be referred to the Installation Manual. Due to continuing improvement, above specifications may be subject to change without notice.		

Notes:	Unit converter
1. Nominal cooling conditions (subject to JIS B8615-2) Indoor: 27°C D.B./19°C W.B. (81°F D.B./66°F W.B.), Outdoor: 35°C D.B./24°C W.B. (95°F D.B./75°F W.B.) Pipe length: 7.5 m (24-9/16 ft.), Level difference: 0 m (0 ft.)	BTU/h = kW x 3,412
2. Nominal heating conditions (subject to JIS B8615-2) Indoor: 20°C D.B. (68°F D.B.), Outdoor: 7°C D.B./6°C W.B. (45°F D.B./43°F W.B.) Pipe length: 7.5 m (24-9/16 ft.), Level difference: 0 m (0 ft.)	cfm = m ³ /min x 35.31
3. -5°C D.B. (23°F D.B.)/-6°C W.B. (21°F W.B.) to 21°C D.B. (70°F D.B.)/15.5°C W.B. (60°F W.B.) with cooling/heating mixed operation.	lbs = kg/0.4536
4. External static pressure option is available (30 Pa, 60 Pa/3.1 mmH ₂ O, 6.1 mmH ₂ O).	*Above specification data is subject to rounding variation.

1. SPECIFICATIONS

YKB/YLM

Model		PURY-P400YSLM-A1 (-BS)	
Power source		3-phase 4-wire 380-400-415 V 50/60 Hz	
Cooling capacity (Nominal)	*1 kW	45.0	
	kcal/h	40,000	
	*1 BTU/h	153,500	
	Power input kW	10.97	
	Current input A	18.5-17.5-16.9	
EER	kW/kW		4.10
Temp. range of cooling	*3 Indoor	W.B.	15.0~24.0°C (59~75°F)
	Outdoor	D.B.	-5.0~46.0°C (23~115°F)
Heating capacity (Nominal)	*2 kW	50.0	
	kcal/h	45,000	
	*2 BTU/h	170,600	
	Power input kW	10.98	
	Current input A	18.5-17.6-16.9	
COP	kW/kW		4.55
Temp. range of heating	*3 Indoor	D.B.	15.0~27.0°C (59~81°F)
	Outdoor	W.B.	-20.0~15.5°C (-4~60°F)
Indoor unit connectable	Total capacity		50~150% of outdoor unit capacity
	Model/Quantity		P15~P250/1~40
Sound pressure level (measured in anechoic room)		dB <A>	62
Sound power level (measured in anechoic room)		dB <A>	85.5
Refrigerant piping diameter	High pressure		22.2 (7/8) Brazed
	Low pressure		28.58 (1-1/8) Brazed

Set Model				
Model		PURY-P200YLM-A1 (-BS)	PURY-P200YLM-A1 (-BS)	
FAN	Type x Quantity	Propeller fan x 1	Propeller fan x 1	
	Air flow rate	m ³ /min	185	185
		L/s	3,083	3,083
		cfm	6,532	6,532
	Control, Driving mechanism		Inverter-control, Direct-driven by motor	Inverter-control, Direct-driven by motor
Motor output	kW	0.92 x 1	0.92 x 1	
*4 External static press.	0 Pa (0 mmH ₂ O)		0 Pa (0 mmH ₂ O)	
Compressor	Type x Quantity	Inverter scroll hermetic compressor	Inverter scroll hermetic compressor	
	Manufacture		AC&R Works, MITSUBISHI ELECTRIC CORPORATION	
	Starting method		Inverter	
	Motor output	kW	5.6	
	Case heater	kW	- (- V)	
Lubricant	MEL32		MEL32	
External finish		Pre-coated galvanized steel sheets (+powder coating for -BS type) <MUNSELL 5Y 8/1 or similar>	Pre-coated galvanized steel sheets (+powder coating for -BS type) <MUNSELL 5Y 8/1 or similar>	
External dimension H x W x D	mm	1,710 (1,650 without legs) x 920 x 740	1,710 (1,650 without legs) x 920 x 740	
	in.	67-3/8 (65 without legs) x 36-1/4 x 29-3/16	67-3/8 (65 without legs) x 36-1/4 x 29-3/16	
Protection devices	High pressure protection		High pressure sensor, High pressure switch at 4.15 MPa (601 psi)	
	Inverter circuit (COMP./FAN)		Over-heat protection, Over-current protection	
	Compressor		Over-heat protection	
	Fan motor		Over-current protection	
Refrigerant	Type x original charge		R410A x 9.5 kg (21 lbs)	
	Control		Indoor LEV and BC controller	
Net weight	kg (lbs)	205 (452)	205 (452)	
Heat exchanger		Salt-resistant cross fin & copper tube		
HIC circuit (HIC: Heat Inter-Changer)				
Pipe between unit and distributor	High pressure	mm (in.)	15.88 (5/8) Brazed	
	Low pressure	mm (in.)	19.05 (3/4) Brazed	
Defrosting method				
Drawing		Auto-defrost mode (Reversed refrigerant cycle, Hot gas)		
Standard attachment	External	WKJ94T179		
	Wiring	WKE94G041	WKE94G041	
Optional parts	Document	Installation Manual		
	Accessory	Refrigerant conn. pipe		
Outdoor Twinning kit: CMY-R100VBK-A Joint: CMY-Y102S-G2, CMY-Y102L-G2, CMY-R160-J1 Main BC controller: CMB-P108, 1010, 1013, 1016V-GA1 Sub BC controller: CMB-P104, 108V-GB1, CMB-P1016V-HB1				
Remarks		Details on foundation work, duct work, insulation work, electrical wiring, power source switch, and other items shall be referred to the Installation Manual. Due to continuing improvement, above specifications may be subject to change without notice.		

Notes:	Unit converter
1. Nominal cooling conditions (subject to JIS B8615-2) Indoor: 27°C D.B./19°C W.B. (81°F D.B./66°F W.B.), Outdoor: 35°C D.B./24°C W.B. (95°F D.B./75°F W.B.) Pipe length: 7.5 m (24-9/16 ft.), Level difference: 0 m (0 ft.)	BTU/h = kW x 3.412
2. Nominal heating conditions (subject to JIS B8615-2) Indoor: 20°C D.B. (68°F D.B.), Outdoor: 7°C D.B./6°C W.B. (45°F D.B./43°F W.B.) Pipe length: 7.5 m (24-9/16 ft.), Level difference: 0 m (0 ft.)	cfm = m ³ /min x 35.31
3. -5°C D.B. (23°F D.B.)/-6°C W.B. (21°F W.B.) to 21°C D.B. (70°F D.B.)/15.5°C W.B. (60°F W.B.) with cooling/heating mixed operation.	lbs = kg/0.4536
4. External static pressure option is available (30 Pa, 60 Pa/3.1 mmH ₂ O, 6.1 mmH ₂ O).	*Above specification data is subject to rounding variation.

1. SPECIFICATIONS

Model			PURY-P450YSLM-A1 (-BS)	
Power source			3-phase 4-wire 380-400-415 V 50/60 Hz	
Cooling capacity (Nominal)	*1	kW	50.0	
		kcal/h	45,000	
		BTU/h	170,600	
	Power input	kW	12.50	
		A	21.1-20.0-19.3	
EER	kW/kW	4.00		
Temp. range of cooling	*3 Indoor	W.B.	15.0~24.0°C (59~75°F)	
	Outdoor	D.B.	-5.0~46.0°C (23~115°F)	
Heating capacity (Nominal)	*2	kW	56.0	
		kcal/h	48,200	
		BTU/h	191,100	
	Power input	kW	12.64	
		A	21.3-20.2-19.5	
COP	kW/kW	4.43		
Temp. range of heating	*3 Indoor	D.B.	15.0~27.0°C (59~81°F)	
	Outdoor	W.B.	-20.0~15.5°C (-4~60°F)	
Indoor unit connectable	Total capacity		50~150% of outdoor unit capacity	
	Model/Quantity		P15-P250/1-45	
Sound pressure level (measured in anechoic room)		dB <A>	62.5	
Sound power level (measured in anechoic room)		dB <A>	86	
Refrigerant piping diameter	High pressure	mm (in.)	22.2 (7/8) Brazed	
	Low pressure	mm (in.)	28.58 (1-1/8) Brazed	

Set Model			PURY-P200YLM-A1 (-BS)		PURY-P250YLM-A1 (-BS)	
Model			Propeller fan x 1		Propeller fan x 1	
FAN	Type x Quantity		185		185	
	Air flow rate	m ³ /min	3,083		3,083	
		L/s	6,532		6,532	
		cfm				
	Control, Driving mechanism		Inverter-control, Direct-driven by motor		Inverter-control, Direct-driven by motor	
*4 Motor output	kW	0.92 x 1		0.92 x 1		
External static press.		0 Pa (0 mmH ₂ O)		0 Pa (0 mmH ₂ O)		
Compressor			Inverter scroll hermetic compressor		Inverter scroll hermetic compressor	
Manufacture			AC&R Works, MITSUBISHI ELECTRIC CORPORATION		AC&R Works, MITSUBISHI ELECTRIC CORPORATION	
Starting method			Inverter		Inverter	
Motor output		kW	5.6		6.9	
Case heater		kW	- (- V)		- (- V)	
Lubricant			MEL32		MEL32	
External finish			Pre-coated galvanized steel sheets (+powder coating for -BS type) <MUNSELL 5Y 8/1 or similar>		Pre-coated galvanized steel sheets (+powder coating for -BS type) <MUNSELL 5Y 8/1 or similar>	
External dimension H x W x D		mm	1,710 (1,650 without legs) x 920 x 740		1,710 (1,650 without legs) x 920 x 740	
		in.	67-3/8 (65 without legs) x 36-1/4 x 29-3/16		67-3/8 (65 without legs) x 36-1/4 x 29-3/16	
Protection devices	High pressure protection		High pressure sensor, High pressure switch at 4.15 MPa (601 psi)		High pressure sensor, High pressure switch at 4.15 MPa (601 psi)	
	Inverter circuit (COMP./FAN)		Over-heat protection, Over-current protection		Over-heat protection, Over-current protection	
	Compressor		Over-heat protection		Over-heat protection	
	Fan motor		Over-current protection		Over-current protection	
Refrigerant	Type x original charge		R410A x 9.5 kg (21 lbs)		R410A x 9.5 kg (21 lbs)	
	Control		Indoor LEV and BC controller			
Net weight		kg (lbs)	205 (452)		205 (452)	
Heat exchanger			Salt-resistant cross fin & copper tube		Salt-resistant cross fin & copper tube	
HIC circuit (HIC: Heat Inter-Changer)			-			
Pipe between unit and distributor	High pressure	mm (in.)	15.88 (5/8) Brazed		19.05 (3/4) Brazed	
	Low pressure	mm (in.)	19.05 (3/4) Brazed		-	
Defrosting method			Auto-defrost mode (Reversed refrigerant cycle, Hot gas)			
Drawing	External		WKJ94T179			
	Wiring		WKE94G041		WKE94G041	
Standard attachment	Document		Installation Manual			
	Accessory		Refrigerant conn. pipe			
Optional parts			Outdoor Twinning kit: CMY-R100VBK-A Joint: CMY-Y102S-G2, CMY-Y102L-G2, CMY-R160-J1 Main BC controller: CMB-P108, 1010, 1013, 1016V-GA1 Sub BC controller: CMB-P104, 108V-GB1, CMB-P1016V-HB1			
Remarks			Details on foundation work, duct work, insulation work, electrical wiring, power source switch, and other items shall be referred to the Installation Manual. Due to continuing improvement, above specifications may be subject to change without notice.			

Notes:	Unit converter
1. Nominal cooling conditions (subject to JIS B8615-2) Indoor: 27°C D.B./19°C W.B. (81°F D.B./66°F W.B.), Outdoor: 35°C D.B./24°C W.B. (95°F D.B./75°F W.B.) Pipe length: 7.5 m (24-9/16 ft.), Level difference: 0 m (0 ft.)	BTU/h = kW x 3,412
2. Nominal heating conditions (subject to JIS B8615-2) Indoor: 20°C D.B. (68°F D.B.), Outdoor: 7°C D.B./6°C W.B. (45°F D.B./43°F W.B.) Pipe length: 7.5 m (24-9/16 ft.), Level difference: 0 m (0 ft.)	cfm = m ³ /min x 35.31
3. -5°C D.B. (23°F D.B.)/-6°C W.B. (21°F W.B.) to 21°C D.B. (70°F D.B.)/15.5°C W.B. (60°F W.B.) with cooling/heating mixed operation.	lbs = kg/0.4536
4. External static pressure option is available (30 Pa, 60 Pa/3.1 mmH ₂ O, 6.1 mmH ₂ O).	*Above specification data is subject to rounding variation.

1. SPECIFICATIONS

YKB/YLM

Model			PURY-P500YSLM-A1 (-BS)		
Power source			3-phase 4-wire 380-400-415 V 50/60 Hz		
Cooling capacity (Nominal)	*1	kW	56.0		
		kcal/h	50,000		
		BTU/h	191,100		
	Power input	kW	14.39		
		A	24.2-23.0-22.2		
EER	kW/kW	3.89			
Temp. range of cooling	*3 Indoor	W.B.	15.0~24.0°C (59~75°F)		
	Outdoor	D.B.	-5.0~46.0°C (23~115°F)		
Heating capacity (Nominal)	*2	kW	63.0		
		kcal/h	54,200		
		BTU/h	215,000		
	Power input	kW	14.65		
		A	24.7-23.4-22.6		
COP	kW/kW	4.30			
Temp. range of heating	*3 Indoor	D.B.	15.0~27.0°C (59~81°F)		
	Outdoor	W.B.	-20.0~15.5°C (-4~60°F)		
Indoor unit connectable	Total capacity		50~150% of outdoor unit capacity		
	Model/Quantity		P15~P250/1~50		
Sound pressure level (measured in anechoic room)		dB <A>	63		
Sound power level (measured in anechoic room)		dB <A>	86.5		
Refrigerant piping diameter	High pressure	mm (in.)	22.2 (7/8) Brazed		
	Low pressure	mm (in.)	28.58 (1-1/8) Brazed		

Set Model					
Model		PURY-P250YLM-A1 (-BS)		PURY-P250YLM-A1 (-BS)	
FAN	Type x Quantity		Propeller fan x 1		Propeller fan x 1
	Air flow rate	m ³ /min	185		185
		L/s	3,083		3,083
		cfm	6,532		6,532
	Control, Driving mechanism		Inverter-control, Direct-driven by motor		Inverter-control, Direct-driven by motor
*4 Motor output	kW	0.92 x 1		0.92 x 1	
External static press.		0 Pa (0 mmH ₂ O)		0 Pa (0 mmH ₂ O)	
Compressor	Type x Quantity		Inverter scroll hermetic compressor		Inverter scroll hermetic compressor
	Manufacture		AC&R Works, MITSUBISHI ELECTRIC CORPORATION		AC&R Works, MITSUBISHI ELECTRIC CORPORATION
	Starting method		Inverter		Inverter
	Motor output	kW	6.9		6.9
	Case heater	kW	- (- V)		- (- V)
Lubricant		MEL32		MEL32	
External finish		Pre-coated galvanized steel sheets (+powder coating for -BS type) <MUNSELL 5Y 8/1 or similar>		Pre-coated galvanized steel sheets (+powder coating for -BS type) <MUNSELL 5Y 8/1 or similar>	
External dimension H x W x D		mm	1,710 (1,650 without legs) x 920 x 740		1,710 (1,650 without legs) x 920 x 740
		in.	67-3/8 (65 without legs) x 36-1/4 x 29-3/16		67-3/8 (65 without legs) x 36-1/4 x 29-3/16
Protection devices	High pressure protection		High pressure sensor, High pressure switch at 4.15 MPa (601 psi)		High pressure sensor, High pressure switch at 4.15 MPa (601 psi)
	Inverter circuit (COMP./FAN)		Over-heat protection, Over-current protection		Over-heat protection, Over-current protection
	Compressor		Over-heat protection		Over-heat protection
	Fan motor		Over-current protection		Over-current protection
Refrigerant	Type x original charge		R410A x 9.5 kg (21 lbs)		R410A x 9.5 kg (21 lbs)
	Control		Indoor LEV and BC controller		
Net weight		kg (lbs)	205 (452)		205 (452)
Heat exchanger		Salt-resistant cross fin & copper tube			
HIC circuit (HIC: Heat Inter-Changer)		-			
Pipe between unit and distributor	High pressure	mm (in.)	19.05 (3/4) Brazed		19.05 (3/4) Brazed
	Low pressure	mm (in.)	22.2 (7/8) Brazed		-
Defrosting method		Auto-defrost mode (Reversed refrigerant cycle, Hot gas)			
Drawing	External		WKJ94T179		
	Wiring		WKE94G041		WKE94G041
Standard attachment	Document		Installation Manual		
	Accessory		Refrigerant conn. pipe		
Optional parts		Outdoor Twinning kit: CMY-R100VBK-A Joint: CMY-Y102S-G2, CMY-Y102L-G2, CMY-R160-J1 Main BC controller: CMB-P108, 1010, 1013, 1016V-GA1 Sub BC controller: CMB-P104, 108V-GB1, CMB-P1016V-HB1			
Remarks		Details on foundation work, duct work, insulation work, electrical wiring, power source switch, and other items shall be referred to the Installation Manual. Due to continuing improvement, above specifications may be subject to change without notice.			

Notes:		Unit converter	
1. Nominal cooling conditions (subject to JIS B8615-2) Indoor: 27°C D.B./19°C W.B. (81°F D.B./66°F W.B.), Outdoor: 35°C D.B./24°C W.B. (95°F D.B./75°F W.B.) Pipe length: 7.5 m (24-9/16 ft.), Level difference: 0 m (0 ft.)		BTU/h	=kW x 3,412
2. Nominal heating conditions (subject to JIS B8615-2) Indoor: 20°C D.B. (68°F D.B.), Outdoor: 7°C D.B./6°C W.B. (45°F D.B./43°F W.B.) Pipe length: 7.5 m (24-9/16 ft.), Level difference: 0 m (0 ft.)		cfm	=m ³ /min x 35.31
3. -5°C D.B. (23°F D.B.)/-6°C W.B. (21°F W.B.) to 21°C D.B. (70°F D.B.)/15.5°C W.B. (60°F W.B.) with cooling/heating mixed operation.		lbs	=kg/0.4536
4. External static pressure option is available (30 Pa, 60 Pa/3.1 mmH ₂ O, 6.1 mmH ₂ O).		*Above specification data is subject to rounding variation.	

1. SPECIFICATIONS

Model			PURY-P550YSLM-A1 (-BS)	
Power source			3-phase 4-wire 380-400-415 V 50/60 Hz	
Cooling capacity (Nominal)	*1	kW	63.0	
		kcal/h	54,200	
		BTU/h	215,000	
	Power input	kW	16.89	
		Current input	A	28.5-27.0-26.1
EER		kW/kW	3.73	
Temp. range of cooling	*3 Indoor	W.B.	15.0~24.0°C (59~75°F)	
	Outdoor	D.B.	-5.0~46.0°C (23~115°F)	
Heating capacity (Nominal)	*2	kW	69.0	
		kcal/h	59,300	
		BTU/h	235,400	
	Power input	kW	16.62	
		Current input	A	28.0-26.6-25.6
COP		kW/kW	4.15	
Temp. range of heating	*3 Indoor	D.B.	15.0~27.0°C (59~81°F)	
	Outdoor	W.B.	-20.0~15.5°C (-4~60°F)	
Indoor unit connectable	Total capacity		50~150% of outdoor unit capacity	
	Model/Quantity		P15-P250/2-50	
Sound pressure level (measured in anechoic room)		dB <A>	64.5	
Sound power level (measured in anechoic room)		dB <A>	88	
Refrigerant piping diameter	High pressure	mm (in.)	28.58 (1-1/8) Brazed	
	Low pressure	mm (in.)	28.58 (1-1/8) Brazed	

Set Model			PURY-P250YLM-A1 (-BS)		PURY-P300YLM-A1 (-BS)	
Model			Propeller fan x 1		Propeller fan x 1	
FAN	Type x Quantity		185		230	
	Air flow rate	m ³ /min	3,083		3,833	
		L/s	6,532		8,121	
		cfm	Inverter-control, Direct-driven by motor		Inverter-control, Direct-driven by motor	
	Control, Driving mechanism	0.92 x 1		0.92 x 1		
*4 Motor output	kW	0 Pa (0 mmH ₂ O)		0 Pa (0 mmH ₂ O)		
External static press.			0 Pa (0 mmH ₂ O)		0 Pa (0 mmH ₂ O)	
Compressor			Inverter scroll hermetic compressor		Inverter scroll hermetic compressor	
Type x Quantity			AC&R Works, MITSUBISHI ELECTRIC CORPORATION		AC&R Works, MITSUBISHI ELECTRIC CORPORATION	
Manufacture			Inverter		Inverter	
Starting method			6.9		8.1	
Motor output			- (- V)		- (- V)	
Case heater			kW		kW	
Lubricant			MEL32		MEL32	
External finish			Pre-coated galvanized steel sheets (+powder coating for -BS type) <MUNSELL 5Y 8/1 or similar>		Pre-coated galvanized steel sheets (+powder coating for -BS type) <MUNSELL 5Y 8/1 or similar>	
External dimension H x W x D			1,710 (1,650 without legs) x 920 x 740		1,710 (1,650 without legs) x 1,220 x 740	
			67-3/8 (65 without legs) x 36-1/4 x 29-3/16		67-3/8 (65 without legs) x 48-1/16 x 29-3/16	
Protection devices	High pressure protection		High pressure sensor, High pressure switch at 4.15 MPa (601 psi)		High pressure sensor, High pressure switch at 4.15 MPa (601 psi)	
	Inverter circuit (COMP./FAN)		Over-heat protection, Over-current protection		Over-heat protection, Over-current protection	
	Compressor		Over-heat protection		Over-heat protection	
	Fan motor		Over-current protection		Over-current protection	
Refrigerant	Type x original charge		R410A x 9.5 kg (21 lbs)		R410A x 10.3 kg (23 lbs)	
	Control		Indoor LEV and BC controller			
Net weight			205 (452)		248 (547)	
Heat exchanger			Salt-resistant cross fin & copper tube		Salt-resistant cross fin & copper tube	
HIC circuit (HIC: Heat Inter-Changer)			-		-	
Pipe between unit and distributor	High pressure	mm (in.)	19.05 (3/4) Brazed		19.05 (3/4) Brazed	
	Low pressure	mm (in.)	22.2 (7/8) Brazed		-	
Defrosting method			Auto-defrost mode (Reversed refrigerant cycle, Hot gas)			
Drawing	External		WKJ94T180			
	Wiring		WKE94G041		WKE94G041	
Standard attachment	Document		Installation Manual			
	Accessory		Refrigerant conn. pipe			
Optional parts			Outdoor Twinning kit: CMY-R100VBK2 Joint: CMY-Y102SS-G2, CMY-Y102LS-G2, CMY-R160-J1 Main BC controller: CMB-P108, 1010, 1013, 1016V-GA1 Sub BC controller: CMB-P104, 108V-GB1, CMB-P1016V-HB1			
Remarks			Details on foundation work, duct work, insulation work, electrical wiring, power source switch, and other items shall be referred to the Installation Manual. Due to continuing improvement, above specifications may be subject to change without notice.			

Notes:	Unit converter
1. Nominal cooling conditions (subject to JIS B8615-2) Indoor: 27°C D.B./19°C W.B. (81°F D.B./66°F W.B.), Outdoor: 35°C D.B./24°C W.B. (95°F D.B./75°F W.B.) Pipe length: 7.5 m (24-9/16 ft.), Level difference: 0 m (0 ft.)	BTU/h = kW x 3,412
2. Nominal heating conditions (subject to JIS B8615-2) Indoor: 20°C D.B. (68°F D.B.), Outdoor: 7°C D.B./6°C W.B. (45°F D.B./43°F W.B.) Pipe length: 7.5 m (24-9/16 ft.), Level difference: 0 m (0 ft.)	cfm = m ³ /min x 35.31
3. -5°C D.B. (23°F D.B.)/-6°C W.B. (21°F W.B.) to 21°C D.B. (70°F D.B.)/15.5°C W.B. (60°F W.B.) with cooling/heating mixed operation.	lbs = kg/0.4536
4. External static pressure option is available (30 Pa, 60 Pa/3.1 mmH ₂ O, 6.1 mmH ₂ O).	*Above specification data is subject to rounding variation.

1. SPECIFICATIONS

YKB/YLM

Model			PURY-P600YSLM-A1 (-BS)		
Power source			3-phase 4-wire 380-400-415 V 50/60 Hz		
Cooling capacity (Nominal)	*1	kW	69.0		
		kcal/h	59,300		
		BTU/h	235,400		
	Power input	kW	19.32		
		A	32.6-30.9-29.8		
EER	kW/kW	3.57			
Temp. range of cooling	*3 Indoor	W.B.	15.0~24.0°C (59~75°F)		
	Outdoor	D.B.	-5.0~46.0°C (23~115°F)		
Heating capacity (Nominal)	*2	kW	76.5		
		kcal/h	65,800		
		BTU/h	261,000		
	Power input	kW	19.12		
		A	32.2-30.6-29.5		
COP	kW/kW	4.00			
Temp. range of heating	*3 Indoor	D.B.	15.0~27.0°C (59~81°F)		
	Outdoor	W.B.	-20.0~15.5°C (-4~60°F)		
Indoor unit connectable	Total capacity		50~150% of outdoor unit capacity		
	Model/Quantity		P15~P250/2~50		
Sound pressure level (measured in anechoic room)		dB <A>	65.5		
Sound power level (measured in anechoic room)		dB <A>	89		
Refrigerant piping diameter	High pressure	mm (in.)	28.58 (1-1/8) Brazed		
	Low pressure	mm (in.)	28.58 (1-1/8) Brazed		

Set Model					
Model		PURY-P300YLM-A1 (-BS)		PURY-P300YLM-A1 (-BS)	
FAN	Type x Quantity		Propeller fan x 1		Propeller fan x 1
	Air flow rate	m ³ /min	230		230
		L/s	3,833		3,833
		cfm	8,121		8,121
	Control, Driving mechanism		Inverter-control, Direct-driven by motor		Inverter-control, Direct-driven by motor
	Motor output	kW	0.92 x 1		0.92 x 1
*4 External static press.			0 Pa (0 mmH ₂ O)		0 Pa (0 mmH ₂ O)
Compressor	Type x Quantity		Inverter scroll hermetic compressor		Inverter scroll hermetic compressor
	Manufacture		AC&R Works, MITSUBISHI ELECTRIC CORPORATION		AC&R Works, MITSUBISHI ELECTRIC CORPORATION
	Starting method		Inverter		Inverter
	Motor output	kW	8.1		8.1
	Case heater	kW	- (- V)		- (- V)
	Lubricant		MEL32		MEL32
External finish		Pre-coated galvanized steel sheets (+powder coating for -BS type) <MUNSELL 5Y 8/1 or similar>		Pre-coated galvanized steel sheets (+powder coating for -BS type) <MUNSELL 5Y 8/1 or similar>	
External dimension H x W x D		mm	1,710 (1,650 without legs) x 1,220 x 740		1,710 (1,650 without legs) x 1,220 x 740
		in.	67-3/8 (65 without legs) x 48-1/16 x 29-3/16		67-3/8 (65 without legs) x 48-1/16 x 29-3/16
Protection devices	High pressure protection		High pressure sensor, High pressure switch at 4.15 MPa (601 psi)		High pressure sensor, High pressure switch at 4.15 MPa (601 psi)
	Inverter circuit (COMP./FAN)		Over-heat protection, Over-current protection		Over-heat protection, Over-current protection
	Compressor		Over-heat protection		Over-heat protection
	Fan motor		Over-current protection		Over-current protection
Refrigerant	Type x original charge		R410A x 10.3 kg (23 lbs)		R410A x 10.3 kg (23 lbs)
	Control		Indoor LEV and BC controller		
Net weight		kg (lbs)	248 (547)		248 (547)
Heat exchanger		Salt-resistant cross fin & copper tube			
HIC circuit (HIC: Heat Inter-Changer)		-			
Pipe between unit and distributor	High pressure	mm (in.)	19.05 (3/4) Brazed		19.05 (3/4) Brazed
	Low pressure	mm (in.)	22.2 (7/8) Brazed		-
Defrosting method		Auto-defrost mode (Reversed refrigerant cycle, Hot gas)			
Drawing	External		WKJ94T181		
	Wiring		WKE94G041		WKE94G041
Standard attachment	Document		Installation Manual		
	Accessory		Refrigerant conn. pipe		
Optional parts		Outdoor Twinning kit: CMY-R100VBK2 Joint: CMY-Y102SS-G2, CMY-Y102LS-G2, CMY-R160-J1 Main BC controller: CMB-P108, 1010, 1013, 1016V-GA1 Sub BC controller: CMB-P104, 108V-GB1, CMB-P1016V-HB1			
Remarks		Details on foundation work, duct work, insulation work, electrical wiring, power source switch, and other items shall be referred to the Installation Manual. Due to continuing improvement, above specifications may be subject to change without notice.			

Notes:		Unit converter	
1. Nominal cooling conditions (subject to JIS B8615-2) Indoor: 27°C D.B./19°C W.B. (81°F D.B./66°F W.B.), Outdoor: 35°C D.B./24°C W.B. (95°F D.B./75°F W.B.) Pipe length: 7.5 m (24-9/16 ft.), Level difference: 0 m (0 ft.)		BTU/h	=kW x 3,412
2. Nominal heating conditions (subject to JIS B8615-2) Indoor: 20°C D.B. (68°F D.B.), Outdoor: 7°C D.B./6°C W.B. (45°F D.B./43°F W.B.) Pipe length: 7.5 m (24-9/16 ft.), Level difference: 0 m (0 ft.)		cfm	=m ³ /min x 35.31
3. -5°C D.B. (23°F D.B.)/-6°C W.B. (21°F W.B.) to 21°C D.B. (70°F D.B.)/15.5°C W.B. (60°F W.B.) with cooling/heating mixed operation.		lbs	=kg/0.4536
4. External static pressure option is available (30 Pa, 60 Pa/3.1 mmH ₂ O, 6.1 mmH ₂ O).		*Above specification data is subject to rounding variation.	

1. SPECIFICATIONS

Model			PURY-P650YSLM-A1 (-BS)	
Power source			3-phase 4-wire 380-400-415 V 50/60 Hz	
Cooling capacity (Nominal)	*1	kW	73.0	
		kcal/h	62,800	
		BTU/h	249,100	
	Power input	kW	21.28	
		Current input	A	35.9-34.1-32.8
EER		kW/kW	3.43	
Temp. range of cooling	*3 Indoor	W.B.	15.0~24.0°C (59~75°F)	
	Outdoor	D.B.	-5.0~46.0°C (23~115°F)	
Heating capacity (Nominal)	*2	kW	81.5	
		kcal/h	70,100	
		BTU/h	278,100	
	Power input	kW	20.68	
		Current input	A	34.9-33.1-31.9
COP		kW/kW	3.94	
Temp. range of heating	*3 Indoor	D.B.	15.0~27.0°C (59~81°F)	
	Outdoor	W.B.	-20.0~15.5°C (-4~60°F)	
Indoor unit connectable	Total capacity		50~150% of outdoor unit capacity	
	Model/Quantity		P15-P250/2-50	
Sound pressure level (measured in anechoic room)		dB <A>	65.5	
Sound power level (measured in anechoic room)		dB <A>	89	
Refrigerant piping diameter	High pressure	mm (in.)	28.58 (1-1/8) Brazed	
	Low pressure	mm (in.)	28.58 (1-1/8) Brazed	

Set Model

Model			PURY-P300YLM-A1 (-BS)		PURY-P350YLM-A1 (-BS)	
FAN	Type x Quantity		Propeller fan x 1		Propeller fan x 1	
	Air flow rate	m ³ /min	230		230	
		L/s	3,833		3,833	
		cfm	8,121		8,121	
	Control, Driving mechanism		Inverter-control, Direct-driven by motor		Inverter-control, Direct-driven by motor	
	*4 Motor output	kW	0.92 x 1		0.92 x 1	
External static press.		0 Pa (0 mmH ₂ O)		0 Pa (0 mmH ₂ O)		
Compressor	Type x Quantity		Inverter scroll hermetic compressor		Inverter scroll hermetic compressor	
	Manufacture		AC&R Works, MITSUBISHI ELECTRIC CORPORATION		AC&R Works, MITSUBISHI ELECTRIC CORPORATION	
	Starting method		Inverter		Inverter	
	Motor output	kW	8.1		10.5	
	Case heater	kW	- (- V)		- (- V)	
Lubricant		MEL32		MEL32		
External finish			Pre-coated galvanized steel sheets (+powder coating for -BS type) <MUNSELL 5Y 8/1 or similar>		Pre-coated galvanized steel sheets (+powder coating for -BS type) <MUNSELL 5Y 8/1 or similar>	
External dimension H x W x D			mm 1,710 (1,650 without legs) x 1,220 x 740		mm 1,710 (1,650 without legs) x 1,220 x 740	
			in. 67-3/8 (65 without legs) x 48-1/16 x 29-3/16		in. 67-3/8 (65 without legs) x 48-1/16 x 29-3/16	
Protection devices	High pressure protection		High pressure sensor, High pressure switch at 4.15 MPa (601 psi)		High pressure sensor, High pressure switch at 4.15 MPa (601 psi)	
	Inverter circuit (COMP./FAN)		Over-heat protection, Over-current protection		Over-heat protection, Over-current protection	
	Compressor		Over-heat protection		Over-heat protection	
	Fan motor		Over-current protection		Over-current protection	
Refrigerant	Type x original charge		R410A x 10.3 kg (23 lbs)		R410A x 10.3 kg (23 lbs)	
	Control		Indoor LEV and BC controller			
Net weight		kg (lbs)	248 (547)		248 (547)	
Heat exchanger			Salt-resistant cross fin & copper tube		Salt-resistant cross fin & copper tube	
HIC circuit (HIC: Heat Inter-Changer)			-			
Pipe between unit and distributor	High pressure	mm (in.)	19.05 (3/4) Brazed		19.05 (3/4) Brazed	
	Low pressure	mm (in.)	22.2 (7/8) Brazed		-	
Defrosting method			Auto-defrost mode (Reversed refrigerant cycle, Hot gas)			
Drawing	External		WKJ94T181			
	Wiring		WKE94G041		WKE94G041	
Standard attachment	Document		Installation Manual			
	Accessory		Refrigerant conn. pipe			
Optional parts			Outdoor Twinning kit: CMY-R100VBK2 Joint: CMY-Y102SS-G2, CMY-Y102LS-G2, CMY-R160-J1 Main BC controller: CMB-P108, 1010, 1013, 1016V-GA1 Sub BC controller: CMB-P104, 108V-GB1, CMB-P1016V-HB1			
Remarks			Details on foundation work, duct work, insulation work, electrical wiring, power source switch, and other items shall be referred to the Installation Manual. Due to continuing improvement, above specifications may be subject to change without notice.			

Notes:	Unit converter
1. Nominal cooling conditions (subject to JIS B8615-2) Indoor: 27°C D.B./19°C W.B. (81°F D.B./66°F W.B.), Outdoor: 35°C D.B./24°C W.B. (95°F D.B./75°F W.B.) Pipe length: 7.5 m (24-9/16 ft.), Level difference: 0 m (0 ft.)	BTU/h = kW x 3,412
2. Nominal heating conditions (subject to JIS B8615-2) Indoor: 20°C D.B. (68°F D.B.), Outdoor: 7°C D.B./6°C W.B. (45°F D.B./43°F W.B.) Pipe length: 7.5 m (24-9/16 ft.), Level difference: 0 m (0 ft.)	cfm = m ³ /min x 35.31
3. -5°C D.B. (23°F D.B.)/-6°C W.B. (21°F W.B.) to 21°C D.B. (70°F D.B.)/15.5°C W.B. (60°F W.B.) with cooling/heating mixed operation.	lbs = kg/0.4536
4. External static pressure option is available (30 Pa, 60 Pa/3.1 mmH ₂ O, 6.1 mmH ₂ O).	*Above specification data is subject to rounding variation.

1. SPECIFICATIONS

YKB/YLM

Model			PURY-P700YSLM-A1 (-BS)	
Power source			3-phase 4-wire 380-400-415 V 50/60 Hz	
Cooling capacity (Nominal)	*1	kW	80.0	
		kcal/h	68,800	
		BTU/h	273,000	
	Power input	kW	24.24	
		Current input	A	40.9-38.8-37.4
EER		kW/kW	3.30	
Temp. range of cooling	*3 Indoor	W.B.	15.0~24.0°C (59~75°F)	
	Outdoor	D.B.	-5.0~46.0°C (23~115°F)	
Heating capacity (Nominal)	*2	kW	88.0	
		kcal/h	75,700	
		BTU/h	300,300	
	Power input	kW	22.68	
		Current input	A	38.2-36.3-35.0
COP		kW/kW	3.88	
Temp. range of heating	*3 Indoor	D.B.	15.0~27.0°C (59~81°F)	
	Outdoor	W.B.	-20.0~15.5°C (-4~60°F)	
Indoor unit connectable	Total capacity		50~150% of outdoor unit capacity	
	Model/Quantity		P15~P250/2~50	
Sound pressure level (measured in anechoic room)			dB <A>	
Sound power level (measured in anechoic room)			dB <A>	
Refrigerant piping diameter	High pressure		28.58 (1-1/8) Brazed	
	Low pressure		34.93 (1-3/8) Brazed	

Set Model			PURY-P350YLM-A1 (-BS)		PURY-P350YLM-A1 (-BS)	
FAN	Type x Quantity		Propeller fan x 1		Propeller fan x 1	
	Air flow rate	m ³ /min	230		230	
		L/s	3,833		3,833	
		cfm	8,121		8,121	
	Control, Driving mechanism		Inverter-control, Direct-driven by motor		Inverter-control, Direct-driven by motor	
*4	Motor output	kW	0.92 x 1		0.92 x 1	
	External static press.		0 Pa (0 mmH ₂ O)		0 Pa (0 mmH ₂ O)	
Compressor	Type x Quantity		Inverter scroll hermetic compressor		Inverter scroll hermetic compressor	
	Manufacture		AC&R Works, MITSUBISHI ELECTRIC CORPORATION		AC&R Works, MITSUBISHI ELECTRIC CORPORATION	
	Starting method		Inverter		Inverter	
	Motor output	kW	10.5		10.5	
	Case heater	kW	- (- V)		- (- V)	
	Lubricant		MEL32		MEL32	
External finish			Pre-coated galvanized steel sheets (+powder coating for -BS type) <MUNSELL 5Y 8/1 or similar>		Pre-coated galvanized steel sheets (+powder coating for -BS type) <MUNSELL 5Y 8/1 or similar>	
External dimension H x W x D			mm 1,710 (1,650 without legs) x 1,220 x 740 in. 67-3/8 (65 without legs) x 48-1/16 x 29-3/16		mm 1,710 (1,650 without legs) x 1,220 x 740 in. 67-3/8 (65 without legs) x 48-1/16 x 29-3/16	
Protection devices	High pressure protection		High pressure sensor, High pressure switch at 4.15 MPa (601 psi)		High pressure sensor, High pressure switch at 4.15 MPa (601 psi)	
	Inverter circuit (COMP./FAN)		Over-heat protection, Over-current protection		Over-heat protection, Over-current protection	
	Compressor		Over-heat protection		Over-heat protection	
	Fan motor		Over-current protection		Over-current protection	
Refrigerant	Type x original charge		R410A x 10.3 kg (23 lbs)		R410A x 10.3 kg (23 lbs)	
	Control		Indoor LEV and BC controller			
Net weight			kg (lbs) 248 (547)		kg (lbs) 248 (547)	
Heat exchanger			Salt-resistant cross fin & copper tube		Salt-resistant cross fin & copper tube	
HIC circuit (HIC: Heat Inter-Changer)			-			
Pipe between unit and distributor	High pressure	mm (in.)	19.05 (3/4) Brazed		19.05 (3/4) Brazed	
	Low pressure	mm (in.)	28.58 (1-1/8) Brazed		-	
Defrosting method			Auto-defrost mode (Reversed refrigerant cycle, Hot gas)			
Drawing	External		WKJ94T181			
	Wiring		WKE94G041		WKE94G041	
Standard attachment	Document		Installation Manual			
	Accessory		Refrigerant conn. pipe			
Optional parts			Outdoor Twinning kit: CMY-R200VBK2 Joint: CMY-Y102SS-G2, CMY-Y102LS-G2, CMY-R160-J1 Main BC controller: CMB-P1016V-HA1 Sub BC controller: CMB-P104, 108V-GB1, CMB-P1016V-HB1			
Remarks			Details on foundation work, duct work, insulation work, electrical wiring, power source switch, and other items shall be referred to the Installation Manual. Due to continuing improvement, above specifications may be subject to change without notice.			

Notes:	Unit converter
1. Nominal cooling conditions (subject to JIS B8615-2) Indoor: 27°C D.B./19°C W.B. (81°F D.B./66°F W.B.), Outdoor: 35°C D.B./24°C W.B. (95°F D.B./75°F W.B.) Pipe length: 7.5 m (24-9/16 ft.), Level difference: 0 m (0 ft.)	BTU/h = kW x 3,412
2. Nominal heating conditions (subject to JIS B8615-2) Indoor: 20°C D.B. (68°F D.B.), Outdoor: 7°C D.B./6°C W.B. (45°F D.B./43°F W.B.) Pipe length: 7.5 m (24-9/16 ft.), Level difference: 0 m (0 ft.)	cfm = m ³ /min x 35.31
3. -5°C D.B. (23°F D.B.)/-6°C W.B. (21°F W.B.) to 21°C D.B. (70°F D.B.)/15.5°C W.B. (60°F W.B.) with cooling/heating mixed operation.	lbs = kg/0.4536
4. External static pressure option is available (30 Pa, 60 Pa/3.1 mmH ₂ O, 6.1 mmH ₂ O).	*Above specification data is subject to rounding variation.

1. SPECIFICATIONS

YKB/YLM

Model			PURY-P750YSLM-A1 (-BS)	
Power source			3-phase 4-wire 380-400-415 V 50/60 Hz	
Cooling capacity (Nominal)	*1	kW	85.0	
		kcal/h	73,100	
		BTU/h	290,000	
	Power input	kW	26.23	
		A	44.2-42.0-40.5	
EER	kW/kW	3.24		
Temp. range of cooling	*3 Indoor	W.B.	15.0-24.0°C (59-75°F)	
	Outdoor	D.B.	-5.0-46.0°C (23-115°F)	
Heating capacity (Nominal)	*2	kW	90.0	
		kcal/h	77,400	
		BTU/h	307,100	
	Power input	kW	23.01	
		A	38.8-36.9-35.5	
COP	kW/kW	3.91		
Temp. range of heating	*3 Indoor	D.B.	15.0-27.0°C (59-81°F)	
	Outdoor	W.B.	-20.0-15.5°C (-4-60°F)	
Indoor unit connectable	Total capacity		50-150% of outdoor unit capacity	
	Model/Quantity		P15-P250/2-50	
Sound pressure level (measured in anechoic room)		dB <A>	65.5	
Sound power level (measured in anechoic room)		dB <A>	89	
Refrigerant piping diameter	High pressure	mm (in.)	28.58 (1-1/8) Brazed	
	Low pressure	mm (in.)	34.93 (1-3/8) Brazed	

Set Model			PURY-P350YLM-A1 (-BS)		PURY-P400YLM-A1 (-BS)	
Model			Propeller fan x 1		Propeller fan x 1	
FAN	Type x Quantity		230		230	
	Air flow rate	m ³ /min	3,833		3,833	
		L/s	8,121		8,121	
		cfm				
	Control, Driving mechanism		Inverter-control, Direct-driven by motor		Inverter-control, Direct-driven by motor	
*4 Motor output	kW	0.92 x 1		0.92 x 1		
External static press.		0 Pa (0 mmH ₂ O)		0 Pa (0 mmH ₂ O)		
Compressor			Inverter scroll hermetic compressor		Inverter scroll hermetic compressor	
Manufacture			AC&R Works, MITSUBISHI ELECTRIC CORPORATION		AC&R Works, MITSUBISHI ELECTRIC CORPORATION	
Starting method			Inverter		Inverter	
Motor output		kW	10.5		10.9	
Case heater		kW	- (- V)		- (- V)	
Lubricant			MEL32		MEL32	
External finish			Pre-coated galvanized steel sheets (+powder coating for -BS type) <MUNSELL 5Y 8/1 or similar>		Pre-coated galvanized steel sheets (+powder coating for -BS type) <MUNSELL 5Y 8/1 or similar>	
External dimension H x W x D			1,710 (1,650 without legs) x 1,220 x 740 67-3/8 (65 without legs) x 48-1/16 x 29-3/16		1,710 (1,650 without legs) x 1,220 x 740 67-3/8 (65 without legs) x 48-1/16 x 29-3/16	
Protection devices	High pressure protection		High pressure sensor, High pressure switch at 4.15 MPa (601 psi)		High pressure sensor, High pressure switch at 4.15 MPa (601 psi)	
	Inverter circuit (COMP./FAN)		Over-heat protection, Over-current protection		Over-heat protection, Over-current protection	
	Compressor		Over-heat protection		Over-heat protection	
	Fan motor		Over-current protection		Over-current protection	
Refrigerant	Type x original charge		R410A x 10.3 kg (23 lbs)		R410A x 10.3 kg (23 lbs)	
	Control		Indoor LEV and BC controller			
Net weight		kg (lbs)	248 (547)		246 (543)	
Heat exchanger			Salt-resistant cross fin & copper tube		Salt-resistant cross fin & copper tube	
HIC circuit (HIC: Heat Inter-Changer)			-		-	
Pipe between unit and distributor	High pressure	mm (in.)	19.05 (3/4) Brazed		22.2 (7/8) Brazed	
	Low pressure	mm (in.)	28.58 (1-1/8) Brazed		-	
Defrosting method			Auto-defrost mode (Reversed refrigerant cycle, Hot gas)			
Drawing	External		WKJ94T181			
	Wiring		WKE94G041		WKE94G041	
Standard attachment	Document		Installation Manual			
	Accessory		Refrigerant conn. pipe			
Optional parts			Outdoor Twinning kit: CMY-R200VBK2 Joint: CMY-Y102SS-G2, CMY-Y102LS-G2, CMY-R160-J1 Main BC controller: CMB-P1016V-HA1 Sub BC controller: CMB-P104, 108V-GB1, CMB-P1016V-HB1			
Remarks			Details on foundation work, duct work, insulation work, electrical wiring, power source switch, and other items shall be referred to the Installation Manual. Due to continuing improvement, above specifications may be subject to change without notice.			

Notes:	Unit converter
1. Nominal cooling conditions (subject to JIS B8615-2) Indoor: 27°C D.B./19°C W.B. (81°F D.B./66°F W.B.), Outdoor: 35°C D.B./24°C W.B. (95°F D.B./75°F W.B.) Pipe length: 7.5 m (24-9/16 ft.), Level difference: 0 m (0 ft.)	BTU/h = kW x 3,412
2. Nominal heating conditions (subject to JIS B8615-2) Indoor: 20°C D.B. (68°F D.B.), Outdoor: 7°C D.B./6°C W.B. (45°F D.B./43°F W.B.) Pipe length: 7.5 m (24-9/16 ft.), Level difference: 0 m (0 ft.)	cfm = m ³ /min x 35.31
3. -5°C D.B. (23°F D.B.)/-6°C W.B. (21°F W.B.) to 21°C D.B. (70°F D.B.)/15.5°C W.B. (60°F W.B.) with cooling/heating mixed operation.	lbs = kg/0.4536
4. External static pressure option is available (30 Pa, 60 Pa/3.1 mmH ₂ O, 6.1 mmH ₂ O).	*Above specification data is subject to rounding variation.

R2

1. SPECIFICATIONS

YKB/YLM

Model			PURY-P800YSLM-A1 (-BS)		
Power source			3-phase 4-wire 380-400-415 V 50/60 Hz		
Cooling capacity (Nominal)	*1	kW	90.0		
		kcal/h	77,400		
		BTU/h	307,100		
	Power input	kW	28.30		
		A	47.7-45.3-43.7		
EER	kW/kW	3.18			
Temp. range of cooling	*3 Indoor	W.B.	15.0~24.0°C (59~75°F)		
	Outdoor	D.B.	-5.0~46.0°C (23~115°F)		
Heating capacity (Nominal)	*2	kW	90.0		
		kcal/h	77,400		
		BTU/h	307,100		
	Power input	kW	22.84		
		A	38.5-36.6-35.3		
COP	kW/kW	3.94			
Temp. range of heating	*3 Indoor	D.B.	15.0~27.0°C (59~81°F)		
	Outdoor	W.B.	-20.0~15.5°C (-4~60°F)		
Indoor unit connectable	Total capacity		50~150% of outdoor unit capacity		
	Model/Quantity		P15~P250/2~50		
Sound pressure level (measured in anechoic room)		dB <A>	65.5		
Sound power level (measured in anechoic room)		dB <A>	89		
Refrigerant piping diameter	High pressure	mm (in.)	28.58 (1-1/8) Brazed		
	Low pressure	mm (in.)	34.93 (1-3/8) Brazed		

Set Model					
Model		PURY-P400YLM-A1 (-BS)		PURY-P400YLM-A1 (-BS)	
FAN	Type x Quantity		Propeller fan x 1		Propeller fan x 1
	Air flow rate	m ³ /min	230		230
		L/s	3,833		3,833
		cfm	8,121		8,121
	Control, Driving mechanism		Inverter-control, Direct-driven by motor		Inverter-control, Direct-driven by motor
*4 Motor output	kW	0.92 x 1		0.92 x 1	
External static press.		0 Pa (0 mmH ₂ O)		0 Pa (0 mmH ₂ O)	
Compressor	Type x Quantity		Inverter scroll hermetic compressor		Inverter scroll hermetic compressor
	Manufacture		AC&R Works, MITSUBISHI ELECTRIC CORPORATION		AC&R Works, MITSUBISHI ELECTRIC CORPORATION
	Starting method		Inverter		Inverter
	Motor output	kW	10.9		10.9
	Case heater	kW	- (- V)		- (- V)
Lubricant		MEL32		MEL32	
External finish		Pre-coated galvanized steel sheets (+powder coating for -BS type) <MUNSELL 5Y 8/1 or similar>		Pre-coated galvanized steel sheets (+powder coating for -BS type) <MUNSELL 5Y 8/1 or similar>	
External dimension H x W x D		mm	1,710 (1,650 without legs) x 1,220 x 740		1,710 (1,650 without legs) x 1,220 x 740
		in.	67-3/8 (65 without legs) x 48-1/16 x 29-3/16		67-3/8 (65 without legs) x 48-1/16 x 29-3/16
Protection devices	High pressure protection		High pressure sensor, High pressure switch at 4.15 MPa (601 psi)		High pressure sensor, High pressure switch at 4.15 MPa (601 psi)
	Inverter circuit (COMP./FAN)		Over-heat protection, Over-current protection		Over-heat protection, Over-current protection
	Compressor		Over-heat protection		Over-heat protection
	Fan motor		Over-current protection		Over-current protection
Refrigerant	Type x original charge		R410A x 10.3 kg (23 lbs)		R410A x 10.3 kg (23 lbs)
	Control		Indoor LEV and BC controller		
Net weight		kg (lbs)	246 (543)		246 (543)
Heat exchanger		Salt-resistant cross fin & copper tube			
HIC circuit (HIC: Heat Inter-Changer)		-			
Pipe between unit and distributor	High pressure	mm (in.)	22.2 (7/8) Brazed		22.2 (7/8) Brazed
	Low pressure	mm (in.)	28.58 (1-1/8) Brazed		-
Defrosting method		Auto-defrost mode (Reversed refrigerant cycle, Hot gas)			
Drawing	External		WKJ94T181		
	Wiring		WKE94G041		WKE94G041
Standard attachment	Document		Installation Manual		
	Accessory		Refrigerant conn. pipe		
Optional parts		Outdoor Twinning kit: CMY-R200VBK2 Joint: CMY-Y102SS-G2,CMY-Y102LS-G2,CMY-R160-J1 Main BC controller: CMB-P1016V-HA1 Sub BC controller: CMB-P104,108V-GB1,CMB-P1016V-HB1			
Remarks		Details on foundation work, duct work, insulation work, electrical wiring, power source switch, and other items shall be referred to the Installation Manual. Due to continuing improvement, above specifications may be subject to change without notice.			

Notes:		Unit converter	
1.Nominal cooling conditions (subject to JIS B8615-2) Indoor: 27°C.D.B./19°C.W.B. (81°F.D.B./66°F.W.B.), Outdoor: 35°C.D.B./24°C.W.B. (95°F.D.B./75°F.W.B.) Pipe length: 7.5 m (24-9/16 ft.), Level difference: 0 m (0 ft.)		BTU/h	=kW x 3,412
2.Nominal heating conditions (subject to JIS B8615-2) Indoor: 20°C.D.B. (68°F.D.B.), Outdoor: 7°C.D.B./6°C.W.B. (45°F.D.B./43°F.W.B.) Pipe length: 7.5 m (24-9/16 ft.), Level difference: 0 m (0 ft.)		cfm	=m ³ /min x 35.31
3.-5°C.D.B. (23°F.D.B.)/-6°C.W.B. (21°F.W.B.) to 21°C.D.B. (70°F.D.B.)/15.5°C.W.B. (60°F.W.B.) with cooling/heating mixed operation.		lbs	=kg/0.4536
4.External static pressure option is available (30 Pa, 60 Pa/3.1 mmH ₂ O, 6.1 mmH ₂ O).		*Above specification data is subject to rounding variation.	

1. SPECIFICATIONS

Model			PURY-P850YSLM-A1 (-BS)	
Power source			3-phase 4-wire 380-400-415 V 50/60 Hz	
Cooling capacity (Nominal)	*1	kW	96.0	
		kcal/h	82,600	
		BTU/h	327,600	
	Power input	kW	29.26	
		Current input	A	49.3-46.9-45.2
EER		kW/kW	3.28	
Temp. range of cooling	*3 Indoor	W.B.	15.0~24.0°C (59~75°F)	
	Outdoor	D.B.	-5.0~46.0°C (23~115°F)	
Heating capacity (Nominal)	*2	kW	101.0	
		kcal/h	86,900	
		BTU/h	344,600	
	Power input	kW	26.23	
		Current input	A	44.2-42.0-40.5
COP		kW/kW	3.85	
Temp. range of heating	*3 Indoor	D.B.	15.0~27.0°C (59~81°F)	
	Outdoor	W.B.	-20.0~15.5°C (-4~60°F)	
Indoor unit connectable	Total capacity		50~150% of outdoor unit capacity	
	Model/Quantity		P15-P250/2-50	
Sound pressure level (measured in anechoic room)		dB <A>	65.5	
Sound power level (measured in anechoic room)		dB <A>	89	
Refrigerant piping diameter	High pressure	mm (in.)	28.58 (1-1/8) Brazed	
	Low pressure	mm (in.)	41.28 (1-5/8) Brazed	

Set Model			PURY-P400YLM-A1 (-BS)		PURY-P450YLM-A1 (-BS)	
Model			Propeller fan x 1		Propeller fan x 2	
FAN	Type x Quantity		230		320	
	Air flow rate	m ³ /min	3,833		5,333	
		L/s	8,121		11,299	
		cfm	Inverter-control, Direct-driven by motor		Inverter-control, Direct-driven by motor	
	Control, Driving mechanism	kW		0.92 x 1		0.92 x 2
*4 External static press.	0 Pa (0 mmH ₂ O)		0 Pa (0 mmH ₂ O)		0 Pa (0 mmH ₂ O)	
Compressor	Type x Quantity		AC&R Works, MITSUBISHI ELECTRIC CORPORATION		AC&R Works, MITSUBISHI ELECTRIC CORPORATION	
	Manufacture		Inverter		Inverter	
	Starting method		10.9		12.4	
	Motor output	kW	- (- V)		- (- V)	
	Case heater	kW	MEL32		MEL32	
Lubricant		Pre-coated galvanized steel sheets (+powder coating for -BS type)		Pre-coated galvanized steel sheets (+powder coating for -BS type)		
External finish		<MUNSELL 5Y 8/1 or similar>		<MUNSELL 5Y 8/1 or similar>		
External dimension H x W x D		mm	1,710 (1,650 without legs) x 1,220 x 740		1,710 (1,650 without legs) x 1,750 x 740	
		in.	67-3/8 (65 without legs) x 48-1/16 x 29-3/16		67-3/8 (65 without legs) x 68-15/16 x 29-3/16	
Protection devices	High pressure protection		High pressure sensor, High pressure switch at 4.15 MPa (601 psi)		High pressure sensor, High pressure switch at 4.15 MPa (601 psi)	
	Inverter circuit (COMP./FAN)		Over-heat protection, Over-current protection		Over-heat protection, Over-current protection	
	Compressor		Over-heat protection		Over-heat protection	
	Fan motor		Over-current protection		Over-current protection	
Refrigerant	Type x original charge		R410A x 10.3 kg (23 lbs)		R410A x 11.8 kg (27 lbs)	
	Control		Indoor LEV and BC controller			
Net weight		kg (lbs)	246 (543)		321 (708)	
Heat exchanger		Salt-resistant cross fin & copper tube				
HIC circuit (HIC: Heat Inter-Changer)		-				
Pipe between unit and distributor	High pressure	mm (in.)	22.2 (7/8) Brazed		22.2 (7/8) Brazed	
	Low pressure	mm (in.)	28.58 (1-1/8) Brazed		-	
Defrosting method		Auto-defrost mode (Reversed refrigerant cycle, Hot gas)				
Drawing	External	WKJ94T182				
	Wiring	WKE94G041		WKE94G042		
Standard attachment	Document	Installation Manual				
	Accessory	Refrigerant conn. pipe				
Optional parts		Outdoor Twinning kit: CMY-R200XLVBK Joint: CMY-Y102SS-G2, CMY-Y102LS-G2, CMY-R160-J1 Main BC controller: CMB-P1016V-HA1 Sub BC controller: CMB-P104, 108V-GB1, CMB-P1016V-HB1				
Remarks		Details on foundation work, duct work, insulation work, electrical wiring, power source switch, and other items shall be referred to the Installation Manual. Due to continuing improvement, above specifications may be subject to change without notice.				

Notes:	Unit converter
1. Nominal cooling conditions (subject to JIS B8615-2) Indoor: 27°C D.B./19°C W.B. (81°F D.B./66°F W.B.), Outdoor: 35°C D.B./24°C W.B. (95°F D.B./75°F W.B.) Pipe length: 7.5 m (24-9/16 ft.), Level difference: 0 m (0 ft.)	BTU/h = kW x 3,412
2. Nominal heating conditions (subject to JIS B8615-2) Indoor: 20°C D.B. (68°F D.B.), Outdoor: 7°C D.B./6°C W.B. (45°F D.B./43°F W.B.) Pipe length: 7.5 m (24-9/16 ft.), Level difference: 0 m (0 ft.)	cfm = m ³ /min x 35.31
3. -5°C D.B. (23°F D.B.)/-6°C W.B. (21°F W.B.) to 21°C D.B. (70°F D.B.)/15.5°C W.B. (60°F W.B.) with cooling/heating mixed operation.	lbs = kg/0.4536
4. External static pressure option is available (30 Pa, 60 Pa/3.1 mmH ₂ O, 6.1 mmH ₂ O).	*Above specification data is subject to rounding variation.

1. SPECIFICATIONS

YKB/YLM

Model			PURY-P900YSLM-A1 (-BS)	
Power source			3-phase 4-wire 380-400-415 V 50/60 Hz	
Cooling capacity (Nominal)	*1	kW	101.0	
		kcal/h	86,900	
		BTU/h	344,600	
	Power input	kW	29.79	
		A	50.2-47.7-46.0	
EER	kW/kW	3.39		
Temp. range of cooling	*3 Indoor	W.B.	15.0~24.0°C (59~75°F)	
	Outdoor	D.B.	-5.0~46.0°C (23~115°F)	
Heating capacity (Nominal)	*2	kW	113.0	
		kcal/h	97,200	
		BTU/h	385,600	
	Power input	kW	30.13	
		A	50.8-48.3-46.5	
COP	kW/kW	3.75		
Temp. range of heating	*3 Indoor	D.B.	15.0~27.0°C (59~81°F)	
	Outdoor	W.B.	-20.0~15.5°C (-4~60°F)	
Indoor unit connectable	Total capacity		50~150% of outdoor unit capacity	
	Model/Quantity		P15~P250/2~50	
Sound pressure level (measured in anechoic room)		dB <A>	65.5	
Sound power level (measured in anechoic room)		dB <A>	89	
Refrigerant piping diameter	High pressure	mm (in.)	28.58 (1-1/8) Brazed	
	Low pressure	mm (in.)	41.28 (1-5/8) Brazed	

Set Model				
Model			PURY-P450YLM-A1 (-BS)	
Model			PURY-P450YLM-A1 (-BS)	
FAN	Type x Quantity		Propeller fan x 2	
	Air flow rate	m ³ /min	320	
		L/s	5,333	
		cfm	11,299	
	Control, Driving mechanism		Inverter-control, Direct-driven by motor	
*4 Motor output	kW	0.92 x 2		
External static press.		0 Pa (0 mmH ₂ O)		
Compressor	Type x Quantity		Inverter scroll hermetic compressor	
	Manufacture		AC&R Works, MITSUBISHI ELECTRIC CORPORATION	
	Starting method		Inverter	
	Motor output	kW	12.4	
	Case heater	kW	- (- V)	
Lubricant		MEL32		
External finish		Pre-coated galvanized steel sheets (+powder coating for -BS type) <MUNSELL 5Y 8/1 or similar>		
External dimension H x W x D		mm	1,710 (1,650 without legs) x 1,750 x 740	
		in.	67-3/8 (65 without legs) x 68-15/16 x 29-3/16	
Protection devices	High pressure protection		High pressure sensor, High pressure switch at 4.15 MPa (601 psi)	
	Inverter circuit (COMP./FAN)		Over-heat protection, Over-current protection	
	Compressor		Over-heat protection	
	Fan motor		Over-current protection	
Refrigerant	Type x original charge		R410A x 11.8 kg (27 lbs)	
	Control		Indoor LEV and BC controller	
Net weight		kg (lbs)	321 (708)	
Heat exchanger		Salt-resistant cross fin & copper tube		
HIC circuit (HIC: Heat Inter-Changer)		-		
Pipe between unit and distributor	High pressure	mm (in.)	22.2 (7/8) Brazed	
	Low pressure	mm (in.)	28.58 (1-1/8) Brazed	
Defrosting method		Auto-defrost mode (Reversed refrigerant cycle, Hot gas)		
Drawing	External		WKJ94T183	
	Wiring		WKE94G042	WKE94G042
Standard attachment	Document		Installation Manual	
	Accessory		Refrigerant conn. pipe	
Optional parts		Outdoor Twinning kit: CMY-R200XLVBK Joint: CMY-Y102SS-G2, CMY-Y102LS-G2, CMY-R160-J1 Main BC controller: CMB-P1016V-HA1 Sub BC controller: CMB-P104, 108V-GB1, CMB-P1016V-HB1		
Remarks		Details on foundation work, duct work, insulation work, electrical wiring, power source switch, and other items shall be referred to the Installation Manual. Due to continuing improvement, above specifications may be subject to change without notice.		

Notes:	Unit converter
1. Nominal cooling conditions (subject to JIS B8615-2) Indoor: 27°C D.B./19°C W.B. (81°F D.B./66°F W.B.), Outdoor: 35°C D.B./24°C W.B. (95°F D.B./75°F W.B.) Pipe length: 7.5 m (24-9/16 ft.), Level difference: 0 m (0 ft.)	BTU/h = kW x 3,412
2. Nominal heating conditions (subject to JIS B8615-2) Indoor: 20°C D.B. (68°F D.B.), Outdoor: 7°C D.B./6°C W.B. (45°F D.B./43°F W.B.) Pipe length: 7.5 m (24-9/16 ft.), Level difference: 0 m (0 ft.)	cfm = m ³ /min x 35.31
3. -5°C D.B. (23°F D.B.)/-6°C W.B. (21°F W.B.) to 21°C D.B. (70°F D.B.)/15.5°C W.B. (60°F W.B.) with cooling/heating mixed operation.	lbs = kg/0.4536
4. External static pressure option is available (30 Pa, 60 Pa/3.1 mmH ₂ O, 6.1 mmH ₂ O).	*Above specification data is subject to rounding variation.

PURY-P200, 250YLM-A1 (-BS)

Unit : mm

<Accessories>

• Connecting pipe

<Low pressure>

- Pipe (ID ϕ 25.4×OD ϕ 19.05) ... P200 1pc.
- Pipe (ID ϕ 25.4×ID ϕ 22.2) ... P250 1pc.
- Elbow (ID ϕ 19.05×OD ϕ 19.05) ... P200 1pc.

<High pressure>

- Pipe (ID ϕ 25.4×OD ϕ 15.88) ... P200 1pc.
- Pipe (ID ϕ 15.88×ID ϕ 15.88) ... P200 1pc.
- Pipe (ID ϕ 25.4×OD ϕ 19.05) ... P250 1pc.
- Elbow (ID ϕ 19.05×OD ϕ 19.05) ... P250 1pc.

Note1. Please refer to the next page for information regarding necessary spacing around the unit and foundation work.

2. The detachable leg can be removed at site.

3. At brazing of pipes wrap the refrigerant service valve with wet cloth and keep the temperature of refrigerant service valve under 120°C.

Connecting pipe specifications

Model	Refrigerant pipe		Service valve	
	High pressure	Low pressure	High pressure	Low pressure
PURY-P200/YLM-A1(-BS)	ϕ 15.88 Brazed *1	ϕ 19.05 Brazed *1	ϕ 25.4	ϕ 25.4
PURY-P250/YLM-A1(-BS)	ϕ 19.05 Brazed *1	ϕ 22.2 Brazed *1	ϕ 25.4	ϕ 25.4

*1 Use the included connecting pipe and connect to the refrigerant service valve piping.

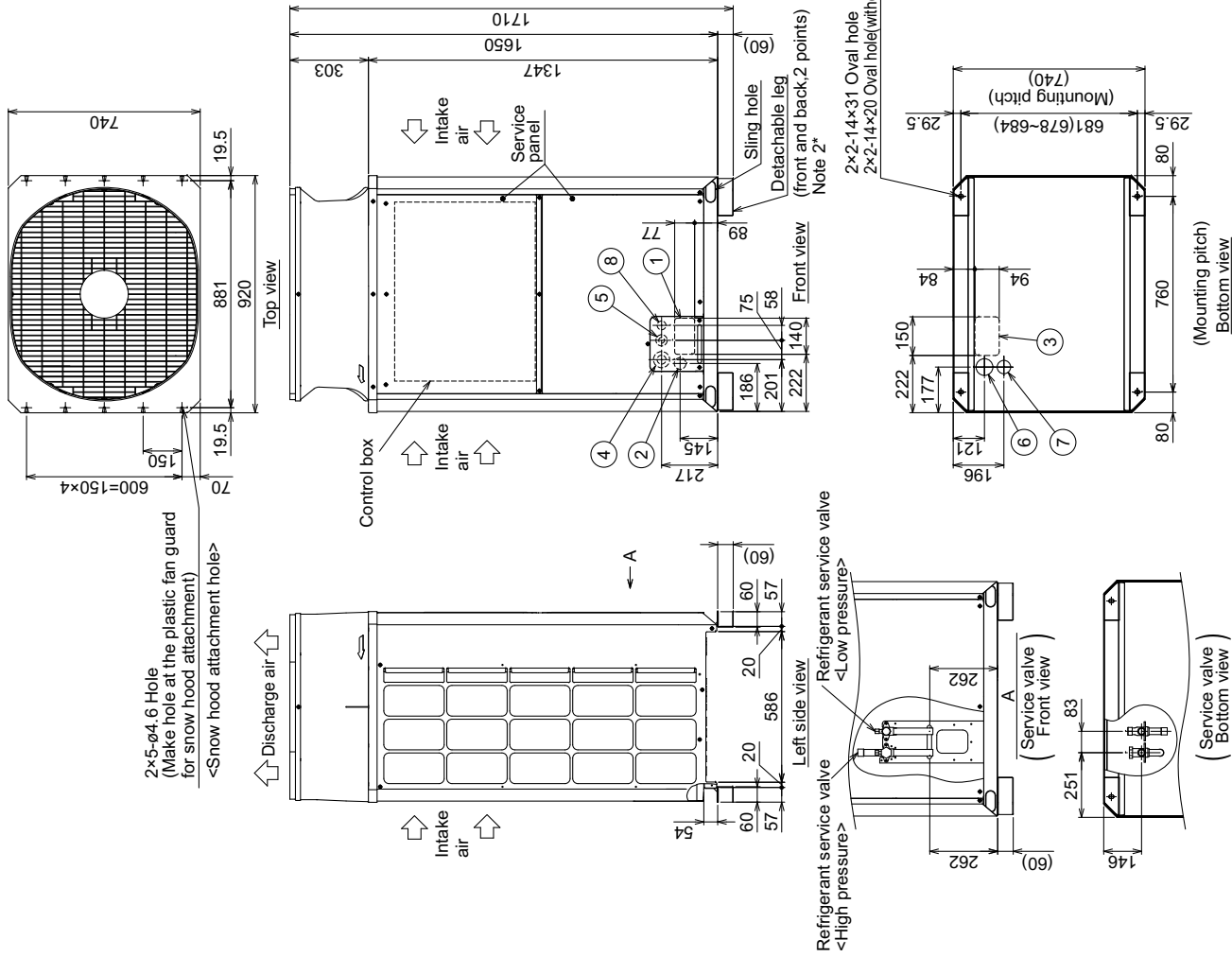

NO	Usage	Specifications
①	Front through hole	140 x 77 Knockout hole
②	Front through hole	ϕ 45 Knockout hole
	(Uses when twinning kit (optional parts) is mounted.)	
③	Bottom through hole	150 x 94 Knockout hole
④	Front through hole	ϕ 65 or ϕ 40 Knockout hole
⑤	Front through hole	ϕ 52 or ϕ 27 Knockout hole
⑥	Bottom through hole	ϕ 65 Knockout hole
⑦	Bottom through hole	ϕ 52 Knockout hole
⑧	For transmission cables	ϕ 34 Knockout hole

PURY-P200, 250YLM-A1 (-BS)

Unit : mm

1. Required space around the unit

● In case of single installation

① Secure enough space around the unit as shown in the figure below.

With a space of at least 100mm to the wall on the back of the unit

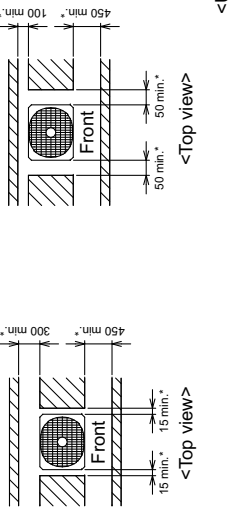

<Unit:mm>

② When the height of the walls on the front, back or on the sides <H> exceeds the wall height limit as defined below add the height that exceeds the height limit <h> to the figures that are marked with an asterisk.

<Wall height limit> Front: Up to the unit height
Back : Up to 500mm from the unit bottom
Side : Up to the unit height

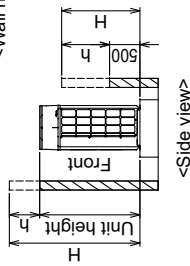

2. Foundation work

- Take into consideration the surface strength, water drainage route, piping route, and wiring route when preparing the installation site.
<Note that the drain water comes out of the unit during operation.>
- Build the foundation in such way that the corner of the installation leg is securely supported as shown in the right figure. (Fig.A,B)
When using a rubber isolating cushion, please ensure it is large enough to cover the entire width of each of the unit's legs.
- The protrusion length of the anchor bolt must not exceed 30mm. (Fig.A,B)
- Use four fixing plates as shown in the right figure <field supply required> when using post-installed anchor bolts. (Fig.C,D)
- To prevent small animals and water and snow from entering the unit and damaging its parts, close the gap around the edges of through holes for pipes and wires with filler plates <field supply required>.
- When the pipes or cables are routed at the bottom of the unit, make sure that the through hole at the base of the unit does not get blocked with the installation base.
- Refer to the Installation Manual when installing units on an installation base.

● In case of collective installation

- When multiple units are installed adjacent to each other, secure enough space to allow for air circulation and walkway between groups of units as shown in the figures below.
- At least two sides must be left open.
- As with the single installation, add the height that exceeds the height limit <h> to the figures that are marked with an asterisk.
- If there is a wall at both the front and the rear of the unit, install up to six units consecutively in the side direction and provide a space of 1000mm or more as inlet space/ passage space for each six units.

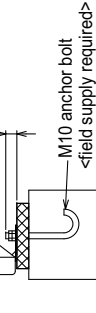
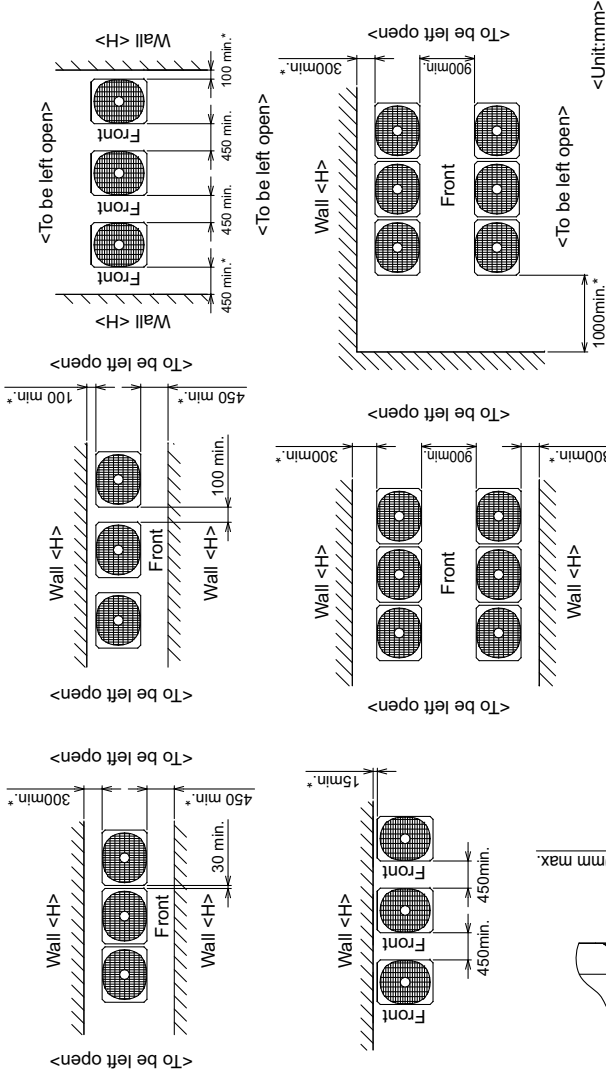

Fig.A (without detachable legs)

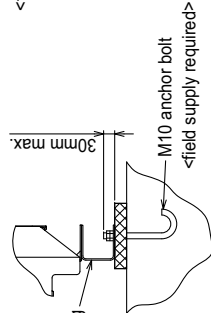

Fig.B (with detachable legs)

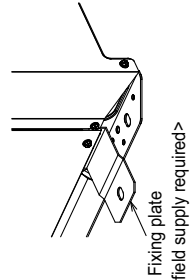

Fig.C (without detachable legs)

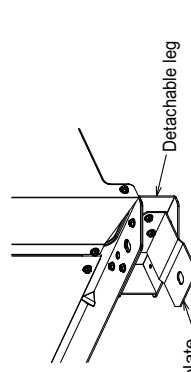

Fig.D (with detachable legs)

PURY-P300, 350, 400YLM-A1 (-BS)

Unit : mm

- <Accessories>
 ●Connecting pipe
 <Low pressure>
 ·Pipe (IDø25.4×IDø22.2) ... P300 1pc.
 ·Pipe (IDø28.58×IDø25.4) ... P350,P400 1pc.
 <High pressure>
 ·Pipe (IDø25.4×ODø19.05) ... P300,P350 1pc.
 ·Pipe (IDø25.4×IDø22.2) ... P400 1pc.
 ·Elbow(IDø19.05×ODø19.05) ... P300,P350 1pc.

Note 1. Please refer to the next page for information regarding necessary spacing around the unit and foundation work.
 2. The detachable leg can be removed at site.
 3. At brazing of pipes, wrap the refrigerant service valve with wet cloth and keep the temperature of refrigerant service valve under 120°C.

Connecting pipe specifications

Model	Refrigerant pipe		Diameter	
	High pressure	Low pressure	High pressure	Low pressure
PURY-P300YLM-A1(-BS)	ø19.05 Brazed *1	ø22.2 Brazed *1	ø25.4	ø25.4
PURY-P350YLM-A1(-BS)	ø19.05 Brazed *1	ø28.58 Brazed *1	ø25.4	ø25.4
PURY-P400YLM-A1(-BS)	ø22.2 Brazed *1	ø28.58 Brazed *1	ø25.4	ø25.4

*1 Use the included connecting pipe and connect to the refrigerant service valve piping.

NO.	Usage	Specifications
①	Front through hole	140 × 77 Knockout hole
②	Front through hole	140 × 77 Knockout hole (Uses when twinning kit (optional parts) is mounted.)
	Bottom through hole	
	Bottom through hole	
③	Front through hole	150 × 94 Knockout hole ø65 or ø40 Knockout hole
	Bottom through hole	
	Bottom through hole	
④	Front through hole	ø52 or ø27 Knockout hole
	Bottom through hole	
⑤	Front through hole	ø52 Knockout hole
	Bottom through hole	
⑥	Front through hole	ø52 Knockout hole
	Bottom through hole	
⑦	Front through hole	ø34 Knockout hole
	Bottom through hole	
⑧	For transmission cables	ø34 Knockout hole

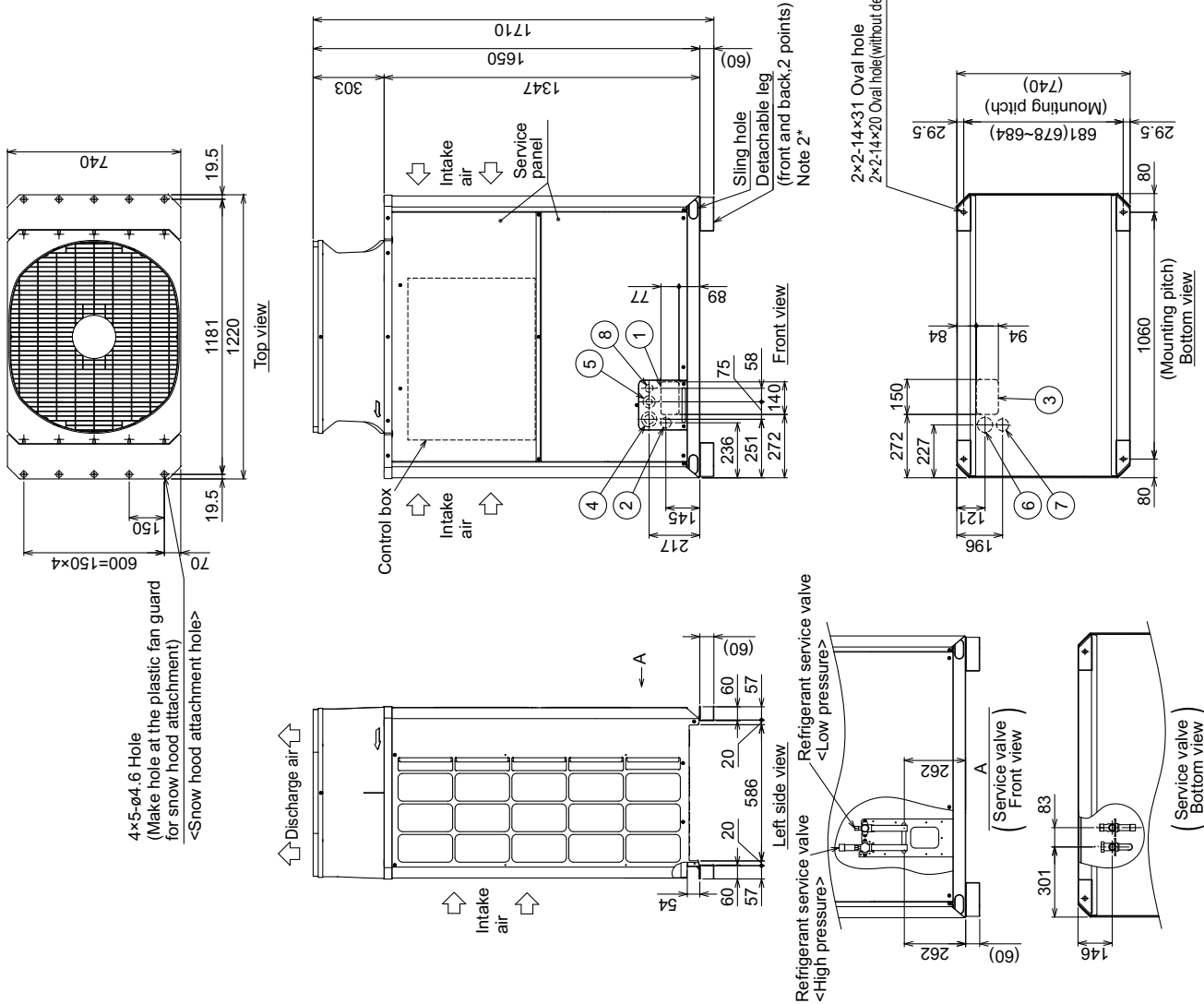

PURY-P300, 350, 400YLM-A1 (-BS)

Unit : mm

● In case of collective installation

- ① When multiple units are installed adjacent to each other, secure enough space to allow for air circulation and walkway between groups of units as shown in the figures below.
- ② At least two sides must be left open.
- ③ As with the single installation, add the height that exceeds the height limit<h> to the figures that are marked with an asterisk.
- ④ If there is a wall at both the front and the rear of the unit, install up to six units consecutively in the side direction and provide a space of 1000mm or more as inlet space/ passage space for each six units.

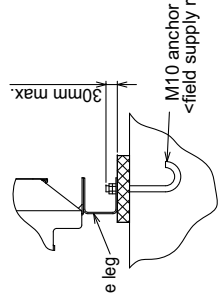
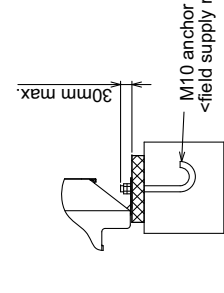
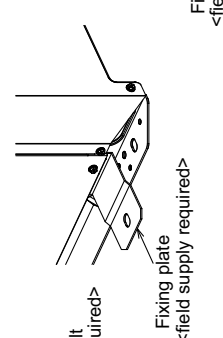
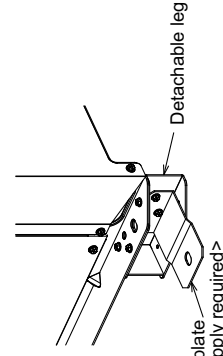
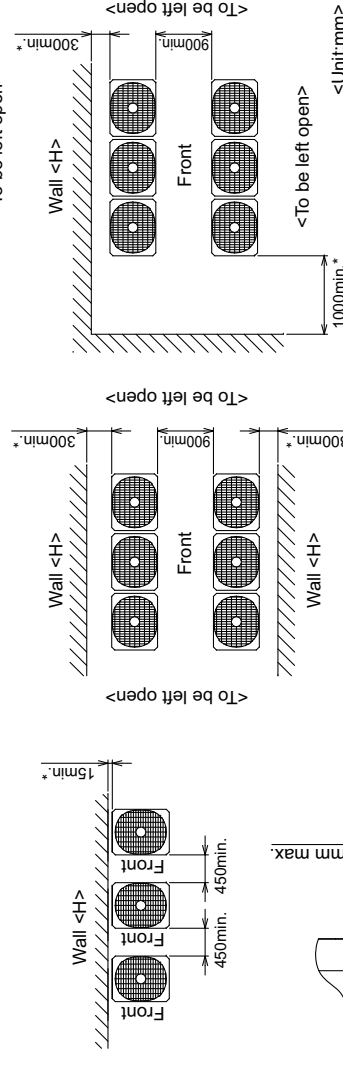
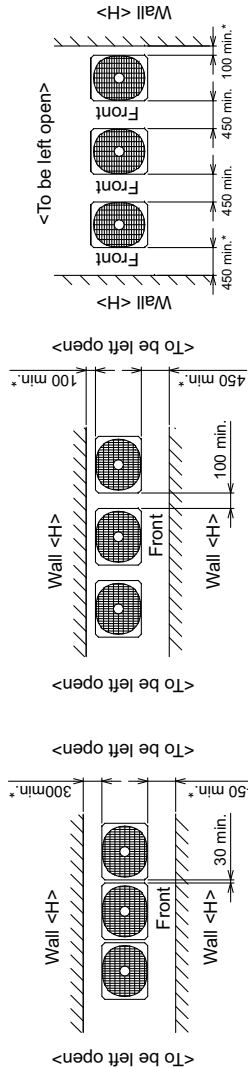

1. Required space around the unit

- In case of single installation
- ① Secure enough space around the unit as shown in the figure below.
 *With a space of at least 100mm to the wall on the back of the unit
 - ② When the height of the walls on the front, back or on the sides<h> exceeds the wall height limit as defined below add the height that exceeds the height limit <h> to the figures that are marked with an asterisk.

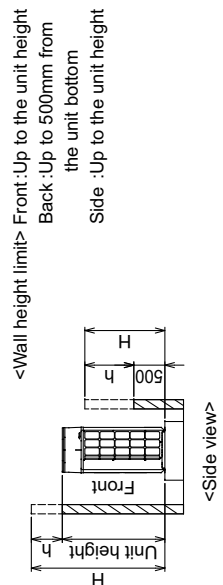
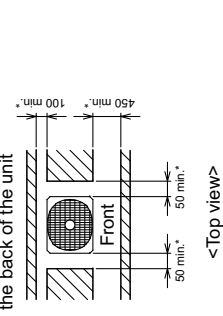

2. Foundation work

- ① Take into consideration the surface strength, water drainage route, piping route, and wiring route when preparing the installation site.
 <Note that the drain water comes out of the unit during operation.>
- ② Build the foundation in such way that the corner of the installation leg is securely supported as shown in the right figure. (Fig. A, B)
 When using a rubber isolating cushion, please ensure it is large enough to cover the entire width of each of the unit's legs.
- ③ The protrusion length of the anchor bolt must not exceed 30mm. (Fig. A, B)
- ④ Use four fixing plates as shown in the right figure. <field supply required>
 when using post-installed anchor bolts. (Fig. C, D)
- ⑤ To prevent small animals and water and snow from entering the unit and damaging its parts, close the gap around the edges of through holes for pipes and wires with filler plates <field supply required>.
- ⑥ When the pipes or cables are routed at the bottom of the unit, make sure that the through hole at the base of the unit does not get blocked with the installation base.
- ⑦ Refer to the Installation Manual when installing units on an installation base.

PURY-P450, 500YLM-A1 (-BS)

Unit : mm

- <Accessories>
- Connecting pipe
 - <Low pressure>
 - Elbow(IDø28.58×ODø28.58) ...P450,P500 1pc.
 - <High pressure>
 - Pipe (IDø25.4×IDø22.2) ...P450,P500 1pc.

Note 1. Please refer to the next page for information regarding necessary spacing around the unit and foundation work.
 2. The detachable leg can be removed at site.
 3. At brazing of pipes, wrap the refrigerant service valve with wet cloth and keep the temperature of refrigerant service valve under 120°C.

Connecting pipe specifications

Model	Refrigerant pipe		Service valve	
	High pressure	Low pressure	High pressure	Low pressure
PURY-P450YLM-A1(-BS)	ø22.2 Brazed *1	ø28.58 Brazed *1	ø25.4	ø28.58
PURY-P500YLM-A1(-BS)				

*1 Use the included connecting pipe and connect to the refrigerant service valve piping.

NO.	Usage	Specifications
①	Front through hole	140 × 77 Knockout hole
②	Front through hole	140 × 77 Knockout hole
	Front through hole (Uses when twinning kit (optional parts) is mounted.)	
③	Bottom through hole	ø45 Knockout hole
④	Front through hole	150 × 94 Knockout hole
⑤	Front through hole	ø65 or ø40 Knockout hole
⑥	Bottom through hole	ø52 or ø27 Knockout hole
⑦	Bottom through hole	ø65 Knockout hole
⑧	Bottom through hole	ø52 Knockout hole
⑨	Front through hole	ø34 Knockout hole

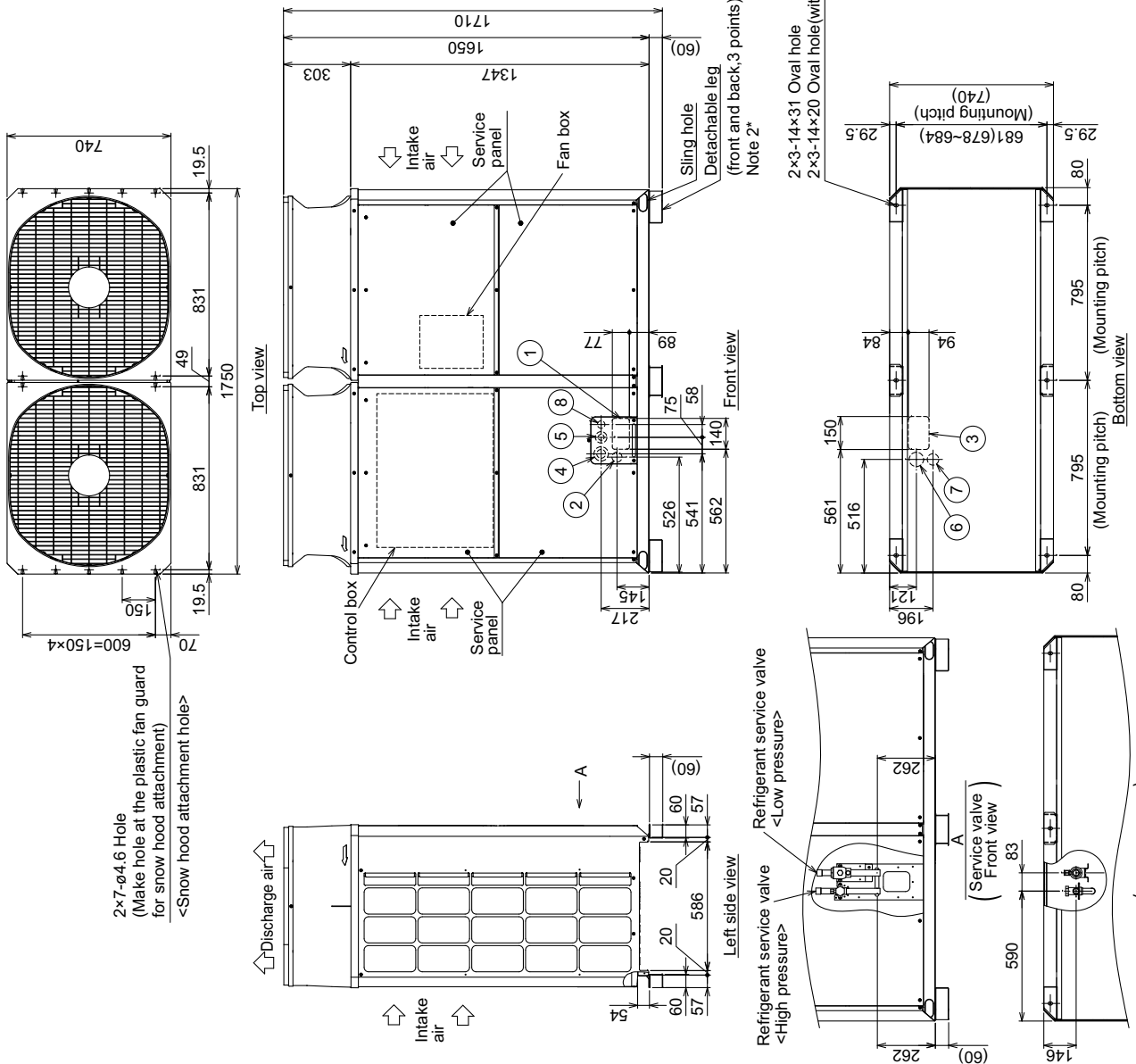

PURY-P450, 500YLM-A1 (-BS)

Unit : mm

● In case of collective installation

- ① When multiple units are installed adjacent to each other, secure enough space to allow for air circulation and walkway between groups of units as shown in the figures below.
- ② At least two sides must be left open.
- ③ As with the single installation, add the height that exceeds the height limit<h> to the figures that are marked with an asterisk.
- ④ If there is a wall at both the front and the rear of the unit, install up to three units consecutively in the side direction and provide a space of 1000mm or more as inlet space/ passage space for each three units.

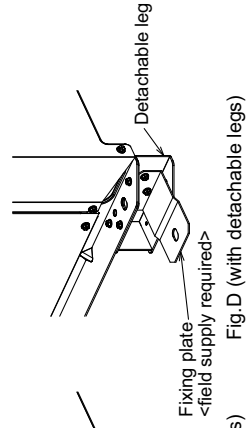
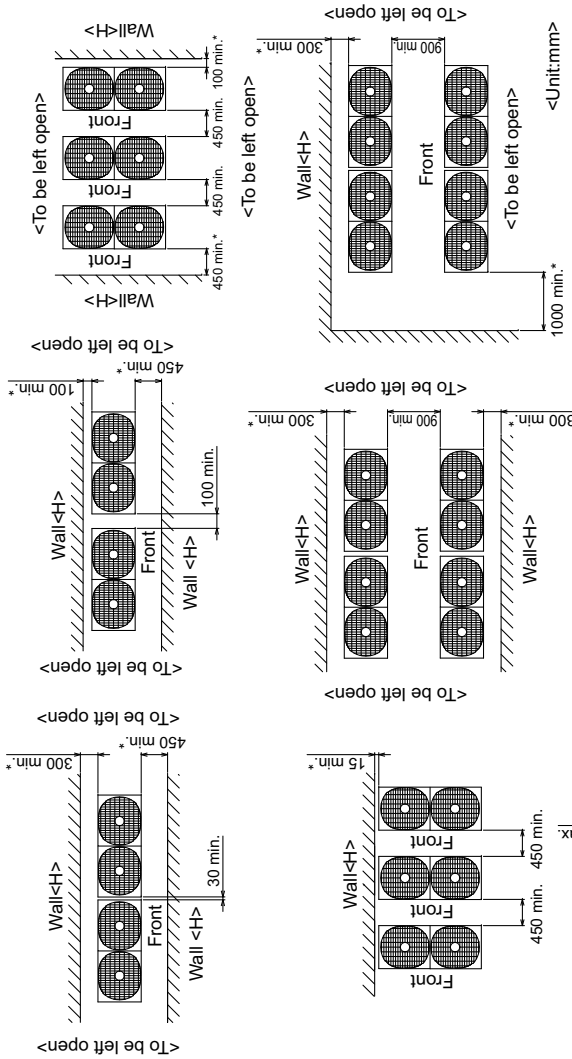

Fig. D (with detachable legs)

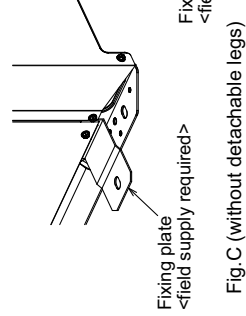
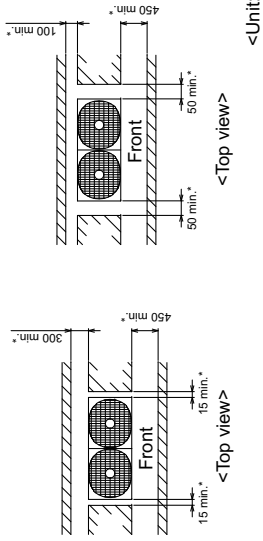

Fig. C (without detachable legs)

1. Required space around the unit

● In case of single installation

- ① Secure enough space around the unit as shown in the figure below.
 - With a space of at least 100mm to the wall on the back of the unit



- ② When the height of the walls on the front, back or on the sides<H> exceeds the wall height limit as defined below add the height that exceeds the height limit <h> to the figures that are marked with an asterisk.

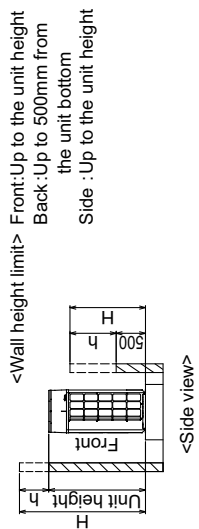

<Wall height limit> Front: Up to the unit height
 Back: Up to 500mm from the unit bottom
 Side : Up to the unit height

2. Foundation work

- ① Take into consideration the surface strength, water drainage route, piping route and wiring route when preparing the installation site.
 - <Note that the drain water comes out of the unit during operation.>
- ② Build the foundation in such way that the corner of the installation leg is securely supported as shown in the right figure.(Fig.A,B)
 - When using a rubber isolating cushion, please ensure it is large enough to cover the entire width of each of the unit's legs.
- ③ The protrusion length of the anchor bolt must not exceed 30mm.(Fig.A,B)
- ④ Use four fixing plates as shown in the right figure <field supply required> when using post-installed anchor bolts.(Fig.C,D)
- ⑤ To prevent small animals and water and snow from entering the unit and damaging its parts, close the gap around the edges of through holes for pipes and wires with filler plates <field supply required>.
- ⑥ When the pipes or cables are routed at the bottom of the unit, make sure that the through hole at the base of the unit does not get blocked with the installation base.
- ⑦ Refer to the Installation Manual when installing units on an installation base.

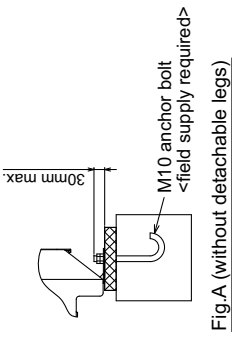

Fig. A (without detachable legs)

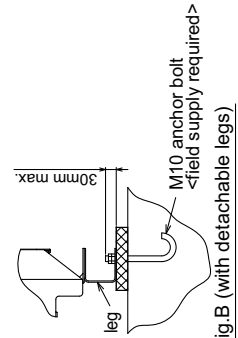
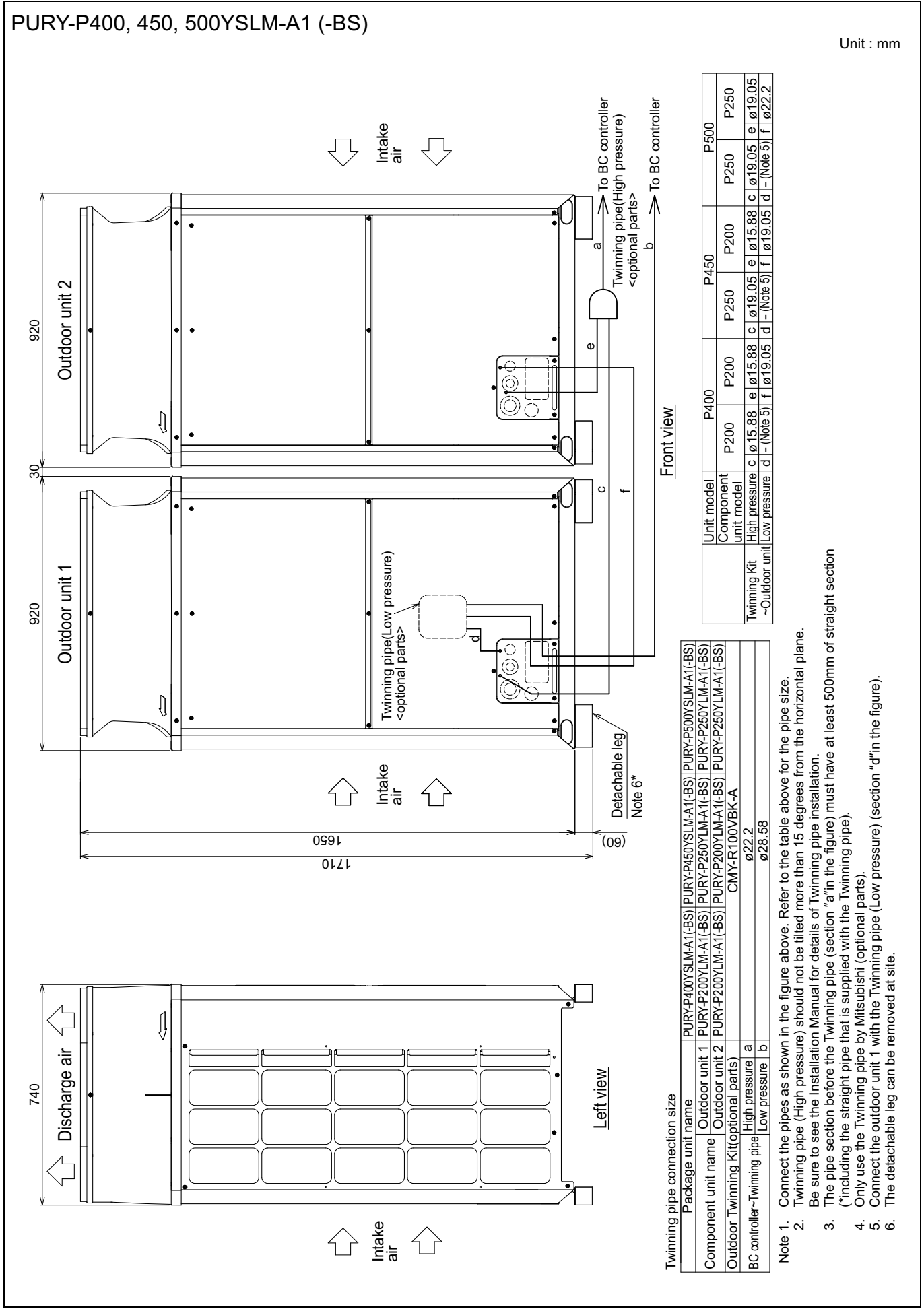
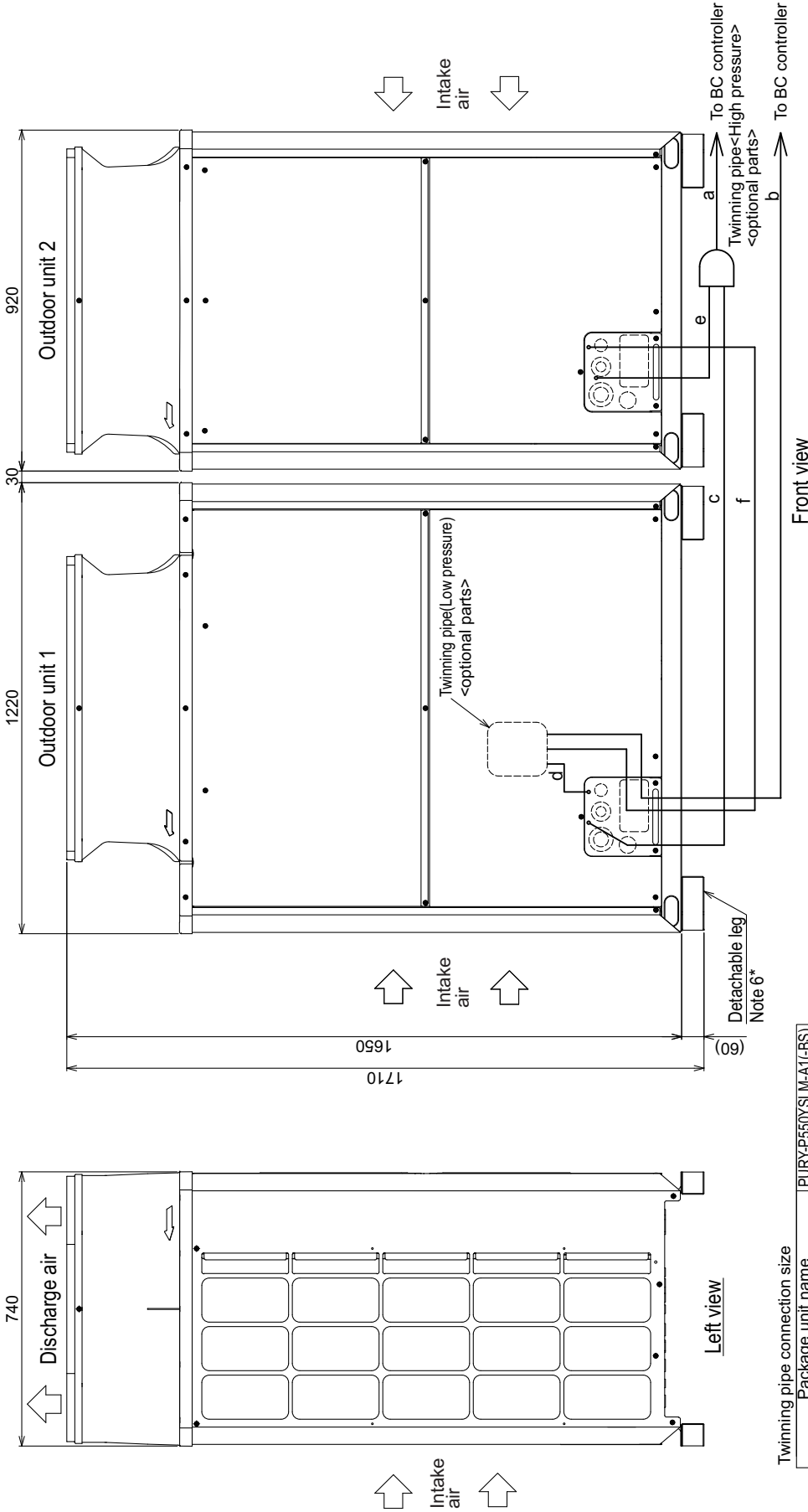

Fig. B (with detachable legs)



PURY-P550YSLM-A1 (-BS)

Unit : mm



Twinning pipe connection size

Package unit name	PURY-P550YSLM-A1(-BS)
Component unit name	Outdoor unit 1 PURY-P300YLM-A1(-BS) Outdoor unit 2 PURY-P250YLM-A1(-BS)
Outdoor Twinning Kit (optional parts)	CMY-R100VBK2
BC controller~ Twinning pipe	High pressure a Low pressure b
	ø28.58 ø28.58

Unit model	P550
Component unit model	P300 P250
Twinning Kit	High pressure c ø19.05 e ø19.05 Low pressure d - (Note 5) f ø22.2

- Note 1. Connect the pipes as shown in the figure above. Refer to the table above for the pipe size.
 2. Twinning pipe (High pressure) should not be tilted more than 15 degrees from the horizontal plane. Be sure to see the Installation Manual for details of Twinning pipe installation.
 3. The pipe section before the Twinning pipe (section "a" in the figure) must have at least 500mm of straight section (*including the straight pipe that is supplied with the Twinning pipe).
 4. Only use the Twinning pipe by Mitsubishi (optional parts).
 5. Connect the outdoor unit 1 with the Twinning pipe (Low pressure) (section "d" in the figure).
 6. The detachable leg can be removed at site.

R2

PURY-P600, 650, 700, 750, 800YSLM-A1 (-BS)

Unit : mm

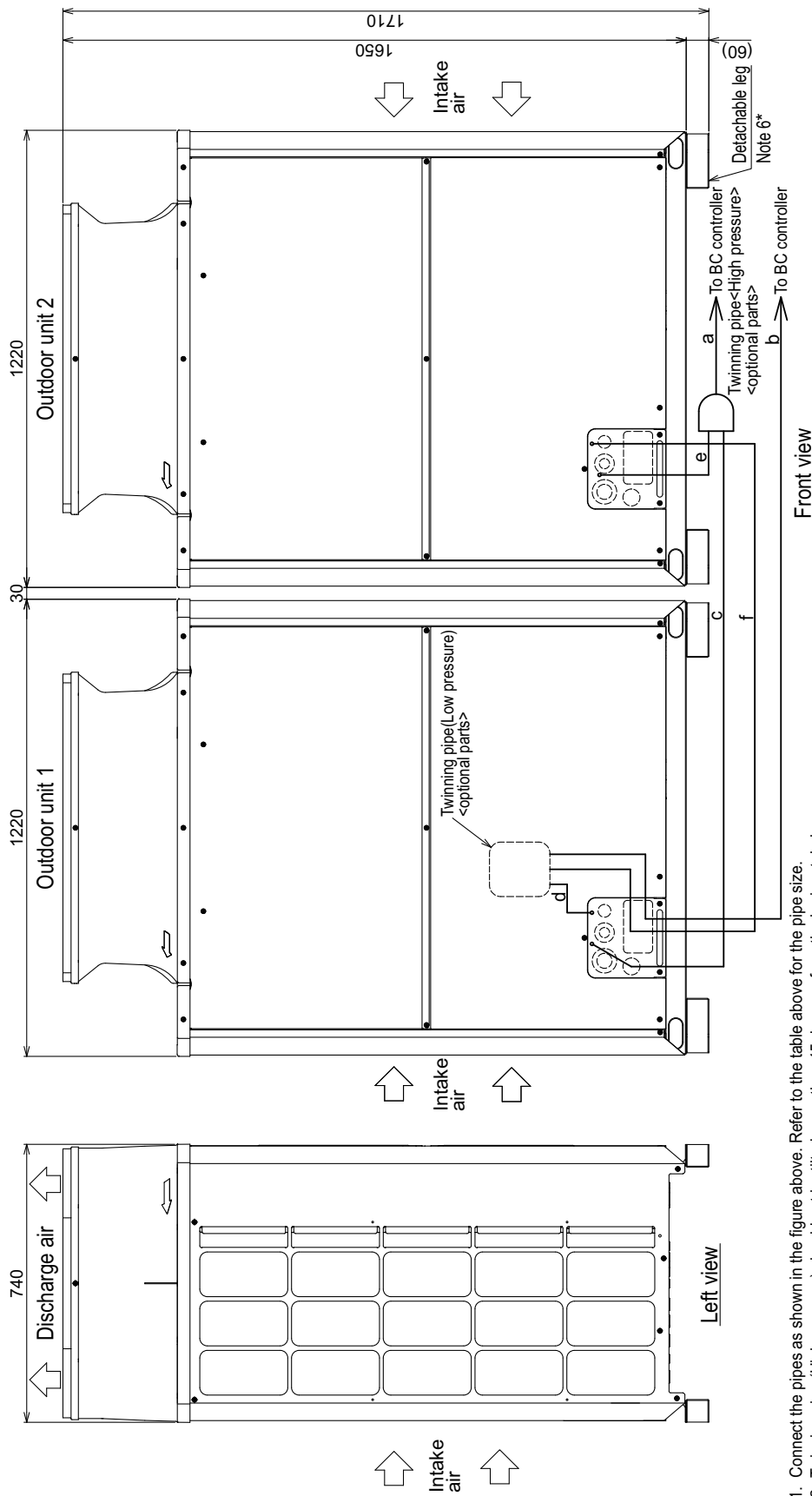

- Note 1. Connect the pipes as shown in the figure above. Refer to the table above for the pipe size.
 2. Twinning pipe (High pressure) should not be tilted more than 15 degrees from the horizontal plane. Be sure to see the Installation Manual for details of Twinning pipe installation.
 3. The pipe section before the Twinning pipe (section "a" in the figure) must have at least 500mm of straight section (*including the straight pipe that is supplied with the Twinning pipe).
 4. Only use the Twinning pipe by Mitsubishi (optional parts).
 5. Connect the outdoor unit 1 with the Twinning pipe (Low pressure) (section "d" in the figure).
 6. The detachable leg can be removed at site.

Twinning pipe connection size

Package unit name	PURY-P600YSLM-A1(-BS)	PURY-P650YSLM-A1(-BS)	PURY-P700YSLM-A1(-BS)	PURY-P750YSLM-A1(-BS)	PURY-P800YSLM-A1(-BS)
Outdoor unit 1	PURY-P300YLM-A1(-BS)	PURY-P350YLM-A1(-BS)	PURY-P400YLM-A1(-BS)	PURY-P450YLM-A1(-BS)	PURY-P400YLM-A1(-BS)
Outdoor unit 2	PURY-P300YLM-A1(-BS)	PURY-P350YLM-A1(-BS)	PURY-P400YLM-A1(-BS)	PURY-P450YLM-A1(-BS)	PURY-P400YLM-A1(-BS)
Outdoor Twinning Kit(optional parts)	CMY-R100VBK2	CMY-R100VBK2	CMY-R200VBK2	CMY-R200VBK2	CMY-R200VBK2
BC controller High pressure la	ø28.58	ø28.58	ø28.58	ø28.58	ø28.58
- Twinning pipe Low pressure lb	ø28.58	ø28.58	ø34.93	ø34.93	ø34.93

Unit model	P600	P650	P700	P750	P800
Component unit model	P300	P350	P400	P450	P400
Twinning Kit High pressure c	ø19.05	ø19.05	ø19.05	ø19.05	ø19.05
-Outdoor unit Low pressure d	ø22.2	ø22.2	ø22.2	ø22.2	ø22.2
	f	ø22.2	d	ø28.58	d
					f
					ø28.58

PURY-P850YSLM-A1 (-BS)

Unit : mm

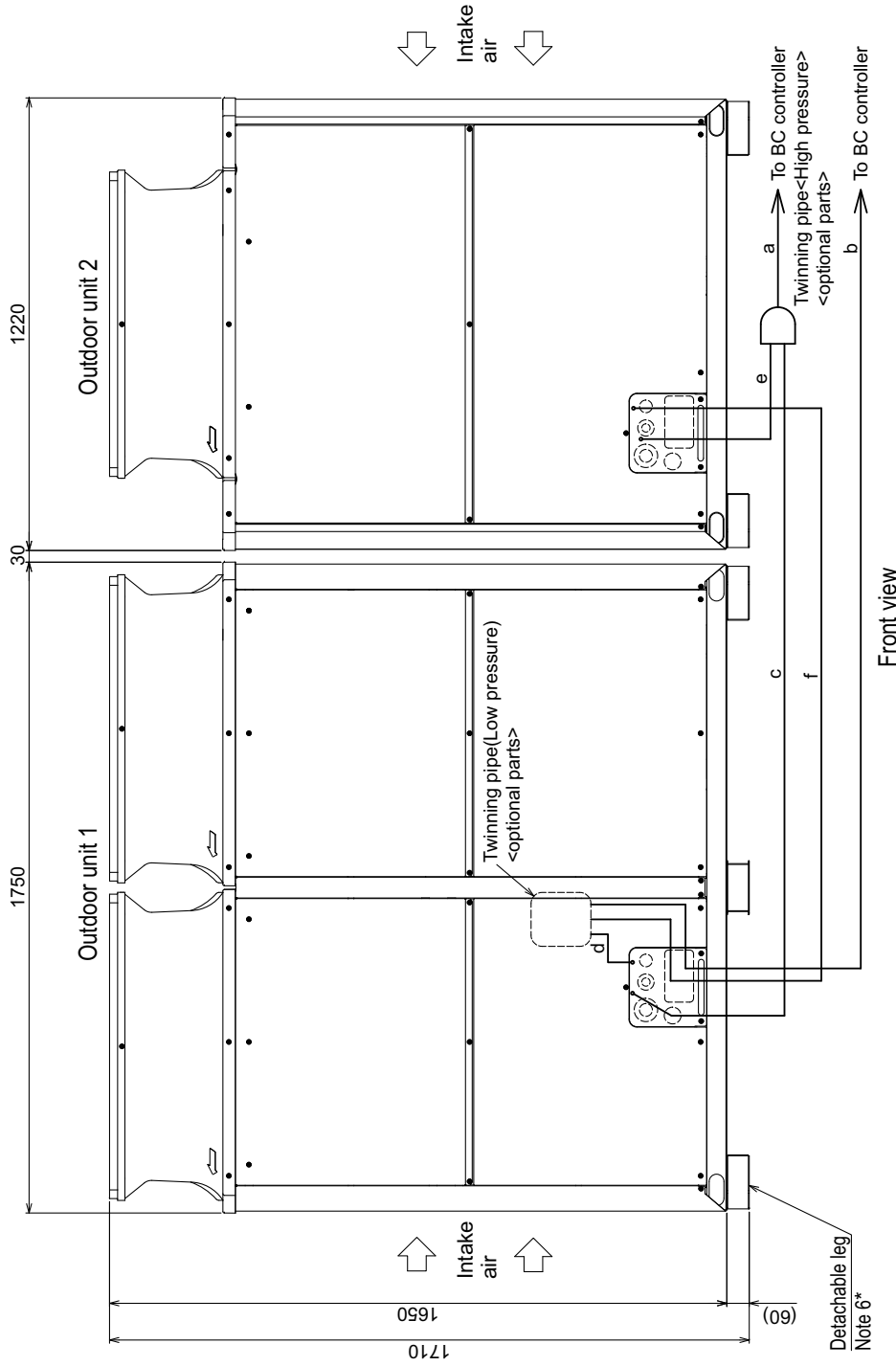

Front view

Left view

Twinning pipe connection size

Package unit name		PURY-P850YSLM-A1(-BS)	
Component unit name	Outdoor unit 1	PURY-P450YLM-A1(-BS)	P850
Outdoor Twinning Kit(optional parts)	Outdoor unit 2	PURY-P400YLM-A1(-BS)	P450
BC controller~Twinning pipe	High pressure	CMY-R200XLVBK	P400
	Low pressure	a	c
		ø28.58	ø22.2
		b	e
		ø41.28	ø28.58

Unit model		P850	
Component unit model	P450	P450	P400
Twinning Kit ~Outdoor unit	High pressure	c	e
	Low pressure	d - (Note 5)	f
		ø22.2	ø28.58

1. Connect the pipes as shown in the figure above. Refer to the table above for the pipe size.
2. Twinning pipe (High pressure) should not be tilted more than 15 degrees from the horizontal plane. Be sure to see the Installation Manual for details of Twinning pipe installation.
3. The pipe section before the Twinning pipe (section "a" in the figure) must have at least 500mm of straight section (*including the straight pipe that is supplied with the Twinning pipe).
4. Only use the Twinning pipe by Mitsubishi (optional parts).
5. Connect the outdoor unit 1 with the Twinning pipe (Low pressure) (section "d" in the figure).
6. The detachable leg can be removed at site.

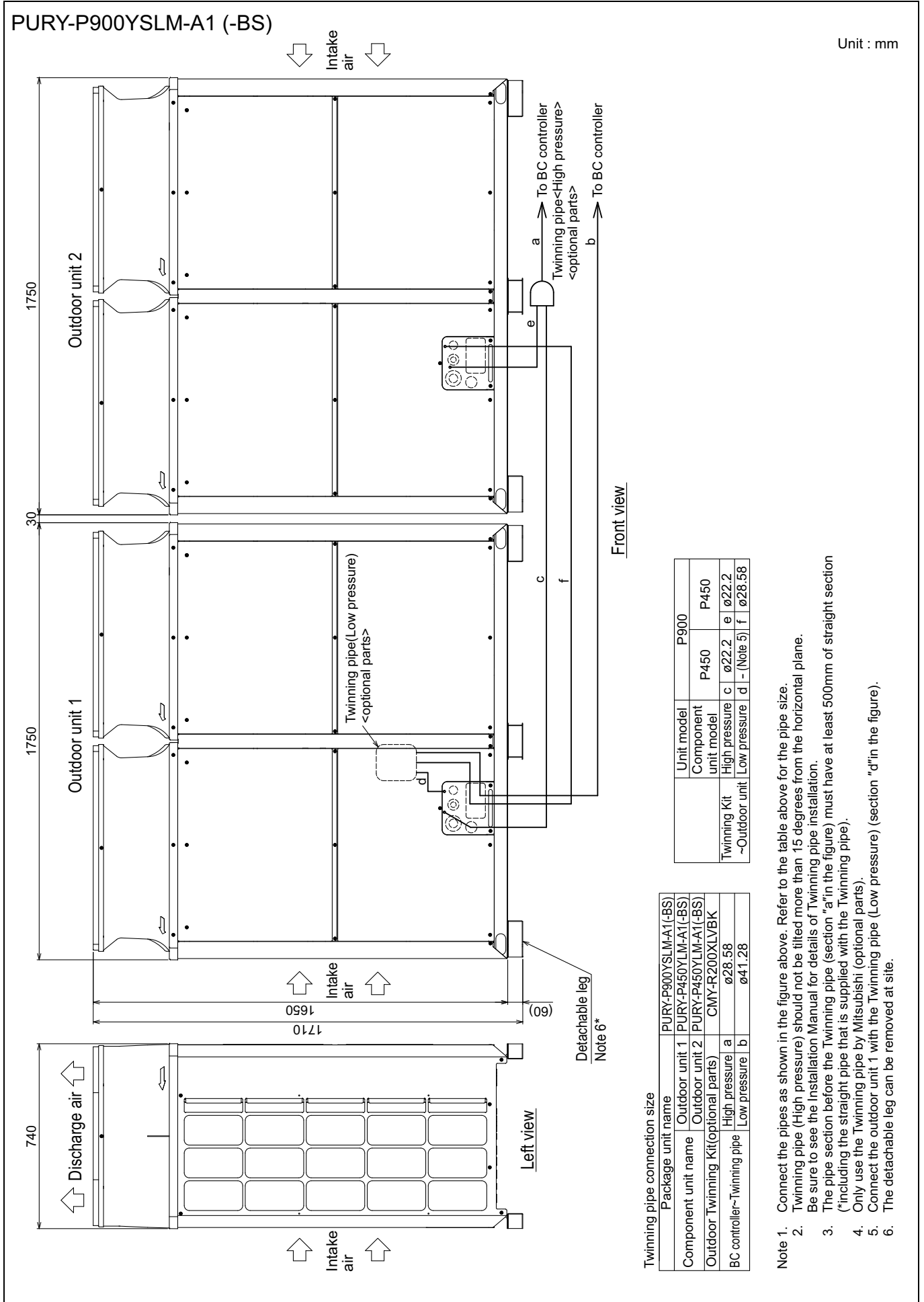

R2

PURY-P200, 250YLM-A1 (-BS)

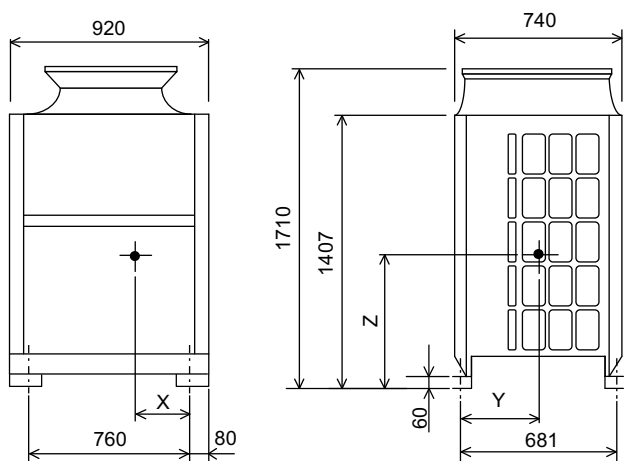

Unit : mm

Model	X	Y	Z
PURY-P200YLM-A1(-BS)	344	309	691
PURY-P250YLM-A1(-BS)	344	309	691

PURY-P300, 350, 400YLM-A1 (-BS)

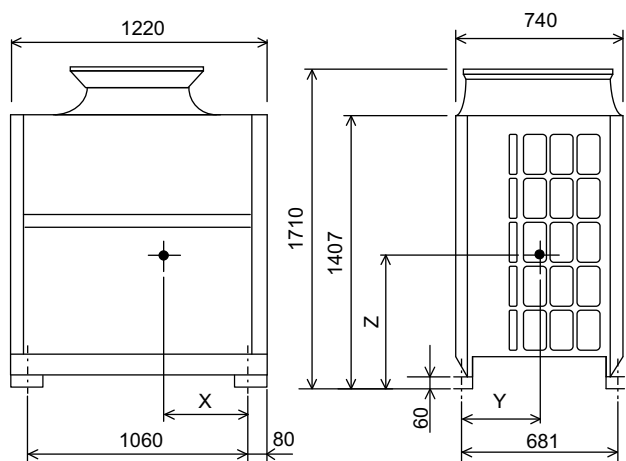

Unit : mm

Model	X	Y	Z
PURY-P300YLM-A1(-BS)	455	314	650
PURY-P350YLM-A1(-BS)	455	314	650
PURY-P400YLM-A1(-BS)	455	314	650

PURY-P450, 500YLM-A1 (-BS)

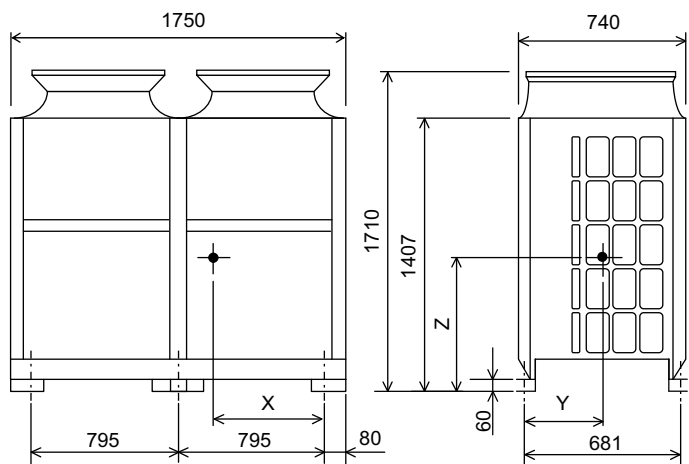

Unit : mm

Model	X	Y	Z
PURY-P450YLM-A1(-BS)	718	327	710
PURY-P500YLM-A1(-BS)	718	327	710

PURY-P200, 250, 300, 350, 400YLM-A1(-BS)

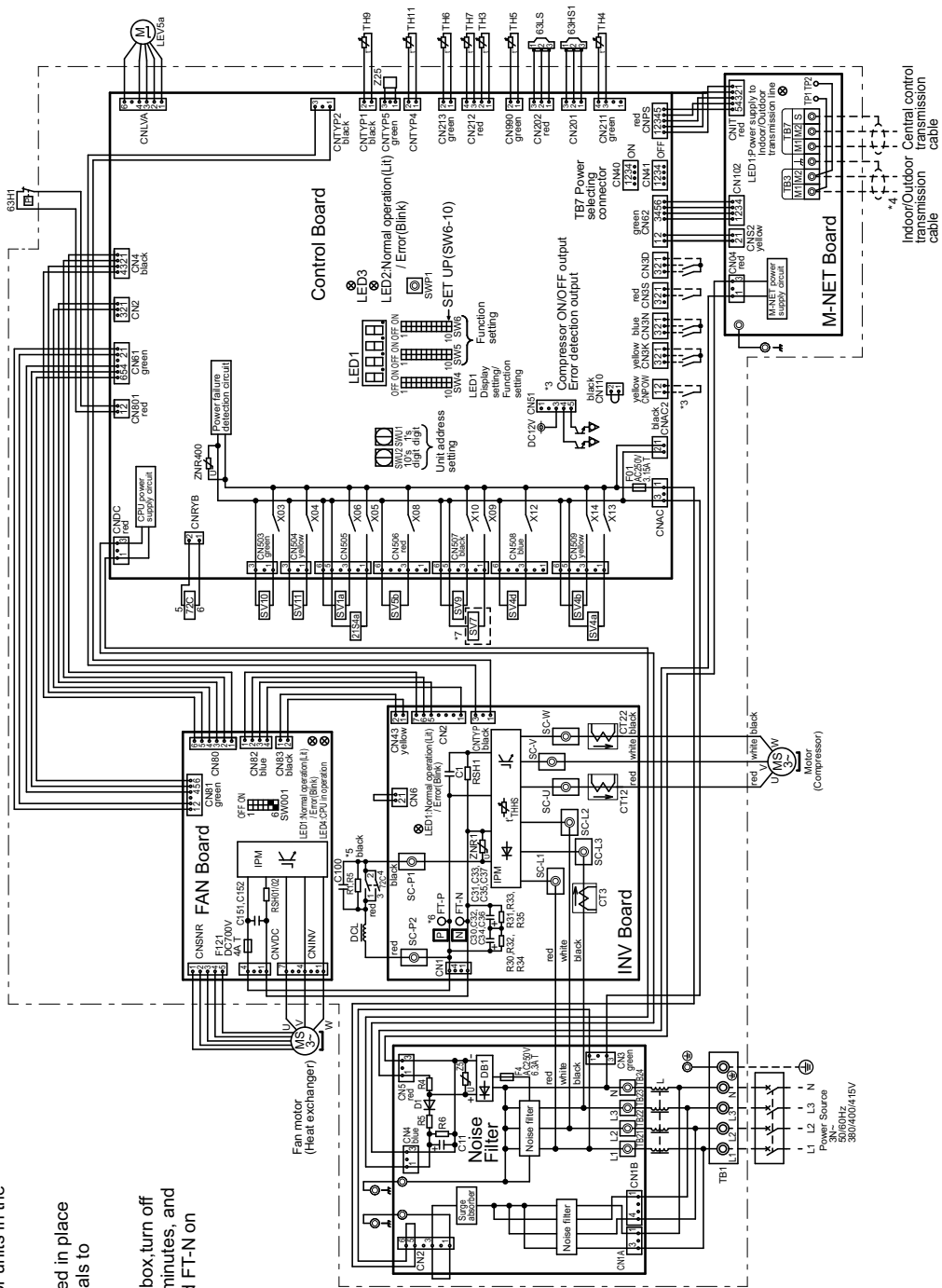

- *1. Single-dotted lines indicate wiring not supplied with the unit.
- *2. Dot-dash lines indicate the control box boundaries.
- *3. Refer to the Data book for connecting input/output signal connectors.
- *4. Daisy-chain terminals (TB3) on the outdoor units in the same refrigerant system together.
- *5. Faston terminals have a locking function. Make sure the terminals are securely locked in place after insertion. Press the tab on the terminals to removed them.
- *6. Control box houses high-voltage parts. Before inspecting the inside of the control box, turn off the power, keep the unit off for at least 10 minutes, and confirm that the voltage between FT-P and FT-N on INV Board has dropped to DC20V or less.
- *7. Difference of appliance.

Model name	appliance
P200/250/300/350/400	*7 do not exist
EP200/250/300/350	*7 exist

<Symbol explanation>

Symbol	Explanation
21S4a	4-way valve(Cooling/Heating switching)
63H1	High pressure protection for the outdoor unit
63HS1	Discharge pressure sensor
63LS	Low pressure sensor
Z2C	Magnetic relay (inverter main circuit)
C30-C37	Capacitor (inverter main circuit)
CT12, CT22, CT3	Current sensor(AC)
DCL	DC reactor
LEV5a	Choke coil (for high frequency noise reduction)
R1.5	Linear expansion valve (for the control of evaporating temperature)
RS101/02, RS11	Resistor
SV1a	Solenoid valve
SV4a, b, d	For opening/closing the bypass circuit under the OS
SV5b	Heat exchanger capacity control
SV7, SV9	Outdoor unit heat exchanger capacity control
SV10, SV11	For opening/closing the bypass circuit
TB1	Terminal block
TB3	Indoor/Outdoor transmission cable
TB7	Central control transmission cable
TH3	Pipe temperature
TH4	Discharge pipe temperature
TH5	ACC inlet pipe temperature
TH6	Subcooled liquid refrigerant temperature
TH7	OA temperature
TH9, TH11	Heat exchanger outlet pipe temperature
THHS	IPM temperature
Z25	Function setting connector

R2

PURY-P450, 500YLM-A1(-BS)

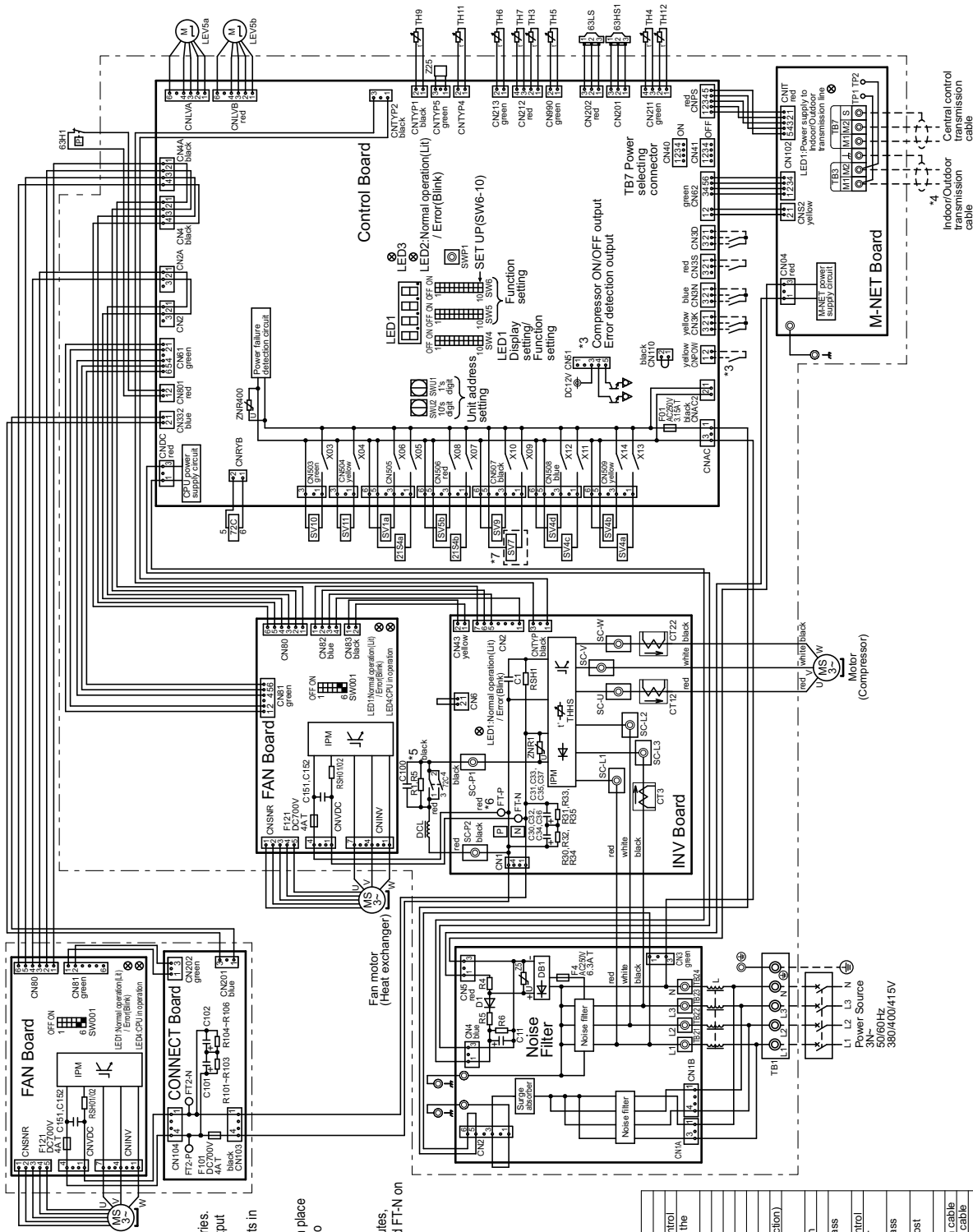

- *1. Single-dotted lines indicate wiring not supplied with the unit.
- *2. Dot-dash lines indicate the control box boundaries.
- *3. Refer to the Data book for connecting input/output signal connectors.
- *4. Daisy-chain terminals (TB3) on the outdoor units in the same refrigerant system together.
- *5. Faston terminals have a locking function. Make sure the terminals are securely locked in place after insertion. Press the tab on the terminals to removed them.
- *6. Control box houses high-voltage parts. Before inspecting the inside of the control box, turn off the power, keep the unit off for at least 10 minutes, and confirm that the voltage between FT-P and FT-N on INV Board has dropped to DC20V or less.
- *7. Difference of appliance.

Model name	appliance
P450/500	-7 do not exist
EP400/450	-7 exist

<Symbol explanation>

Symbol	Explanation
21SAa	4-way valve
21SAb	Cooling/Heating switching
63H1	Heat exchanger capacity control outdoor unit
63HS1	Pressure switch
7ALS	Pressure sensor
C30-C37	Capacitor (bypass main circuit)
CT12/CT13	Current sensor (AC)
DCL	DC reactor
LEV5a,b	Choke coil (for high frequency noise reduction) evaporating temperature
R1.5	Linear expansion valve (for the control of evaporating temperature)
RS102/RS91	Resistor
SV1a	For inrush current prevention
SV4a,b,c,d	For current detection
SV5b	For opening/closing the bypass circuit using the OS
SV7/SV9	Heat exchanger capacity control outdoor unit heat exchanger capacity control
SV10/SV11	For opening/closing the bypass circuit
TB1	For opening/closing the defrost circuit
TB3	Power supply
TB7	Indoor/outdoor transmission cable
TB8	Central control transmission cable
TH3	Pipe temperature
TH4	Discharge pipe temperature
TH5	ACC inlet pipe temperature
TH6	Subcooled liquid refrigerant temperature
TH7	OA temperature
TH1/TH1/TH2	Heat exchanger outlet pipe temperature
TH5S	Pipe temperature
ZS	Function setting connector

Measurement condition
PURY-P200, 250YLM-A1(-BS)

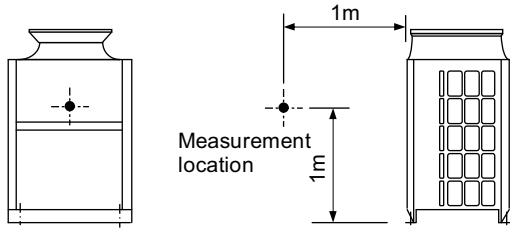

Measurement condition
PURY-P300, 350, 400YLM-A1(-BS)

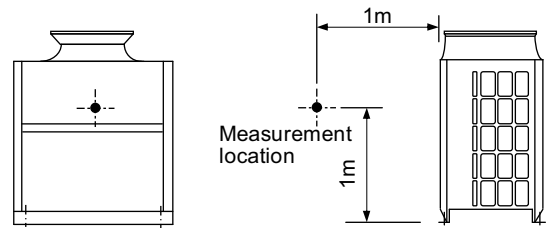

Sound level of PURY-P200YLM-A1(-BS)

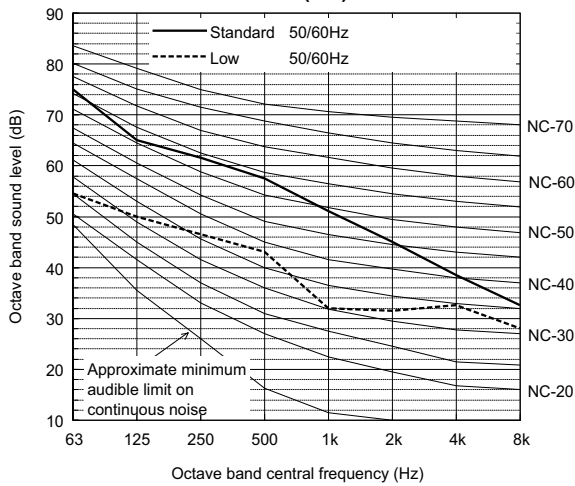

		63	125	250	500	1k	2k	4k	8k	dB(A)
Standard	50/60Hz	75.0	65.0	61.5	57.5	51.0	45.0	38.5	32.5	59.0
Low noise mode	50/60Hz	54.5	50.0	46.5	43.0	32.0	31.5	32.5	28.0	44.0

When Low noise mode is set, the A/C system's capacity is limited. The system could return to normal operation from Low noise mode automatically in the case that the operation condition is severe.

Sound level of PURY-P300YLM-A1(-BS)

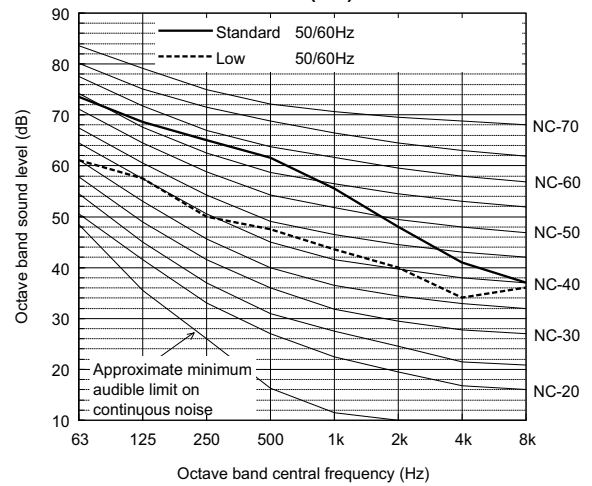

		63	125	250	500	1k	2k	4k	8k	dB(A)
Standard	50/60Hz	73.5	68.5	65.0	61.5	55.5	48.0	41.0	37.0	62.5
Low noise mode	50/60Hz	61.0	57.5	50.0	47.5	43.5	40.0	34.0	36.0	50.0

When Low noise mode is set, the A/C system's capacity is limited. The system could return to normal operation from Low noise mode automatically in the case that the operation condition is severe.

Sound level of PURY-P250YLM-A1(-BS)

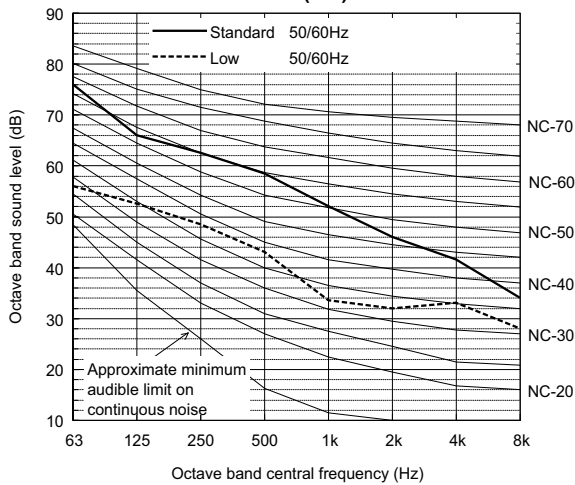

		63	125	250	500	1k	2k	4k	8k	dB(A)
Standard	50/60Hz	76.0	66.0	62.5	58.5	52.0	46.0	41.5	34.0	60.0
Low noise mode	50/60Hz	56.0	52.5	48.5	43.0	33.5	32.0	33.0	28.0	45.0

When Low noise mode is set, the A/C system's capacity is limited. The system could return to normal operation from Low noise mode automatically in the case that the operation condition is severe.

Sound level of PURY-P350YLM-A1(-BS)

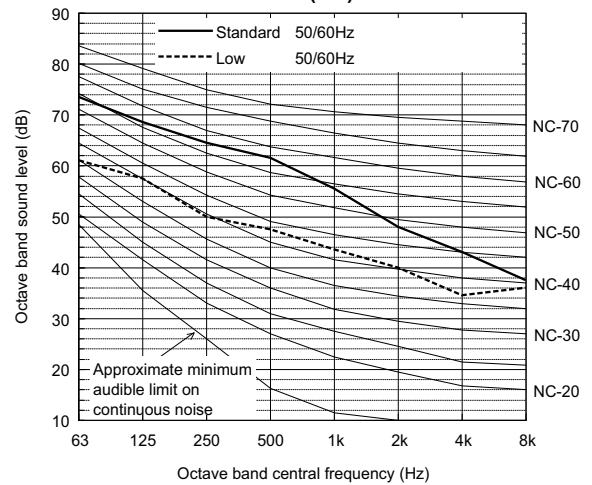

		63	125	250	500	1k	2k	4k	8k	dB(A)
Standard	50/60Hz	73.5	68.5	64.5	61.5	55.5	48.0	43.0	37.5	62.5
Low noise mode	50/60Hz	61.0	57.5	50.0	47.5	43.5	40.0	34.5	36.0	50.0

When Low noise mode is set, the A/C system's capacity is limited. The system could return to normal operation from Low noise mode automatically in the case that the operation condition is severe.

- Depending on the operation conditions, the unit generates noise caused by valve actuation, refrigerant flow, and pressure changes when operating normally. Please consider to avoid location where quietness is required. For BC controller, it is recommended to be installed in places such as ceilings of corridor, rest rooms and plant rooms.

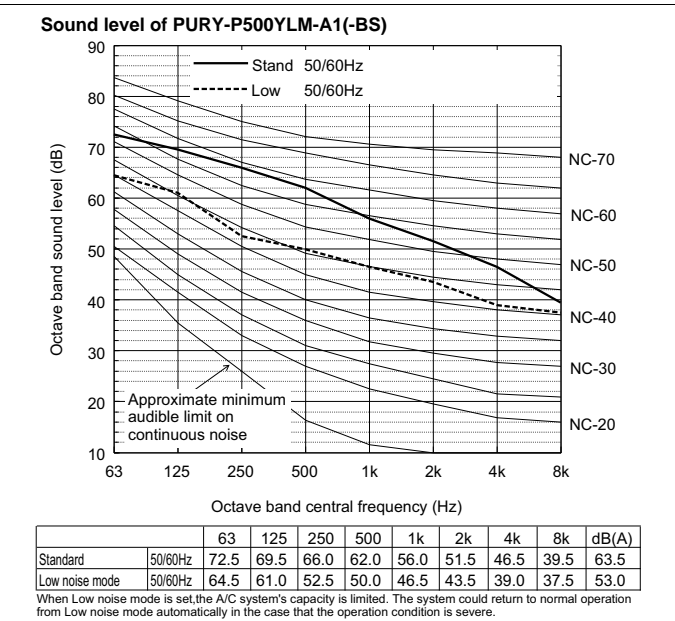
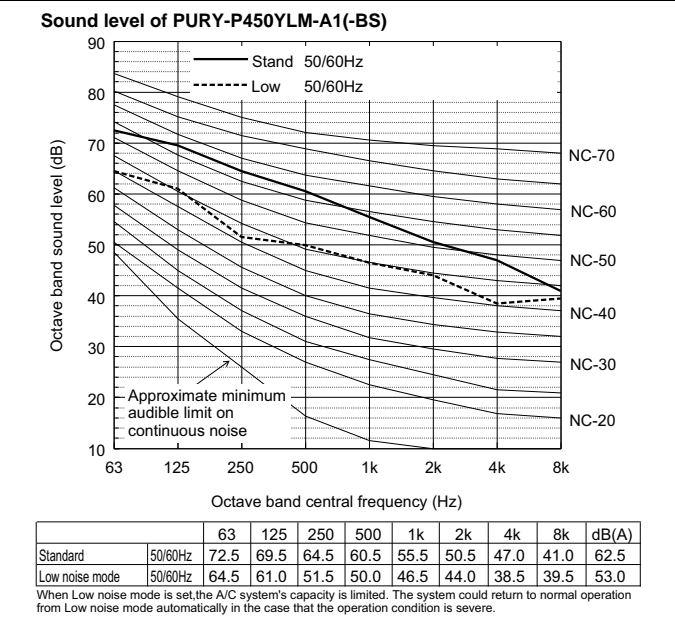
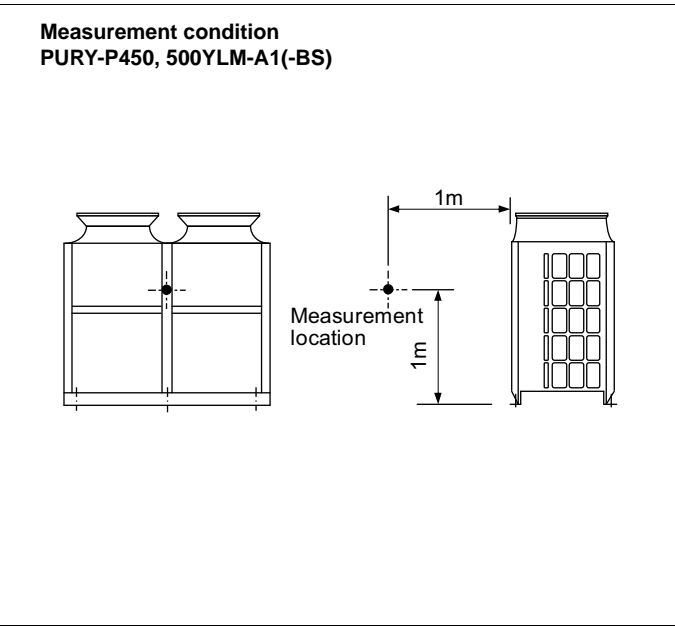
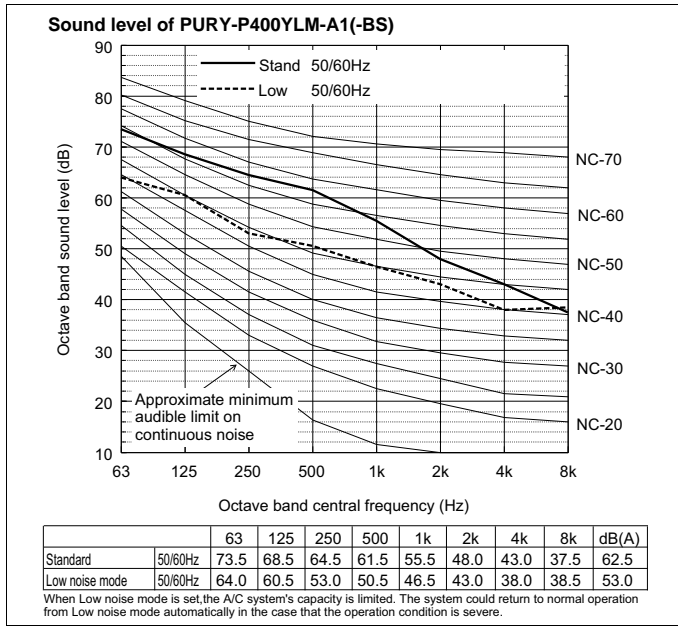

• Depending on the operation conditions, the unit generates noise caused by valve actuation, refrigerant flow, and pressure changes when operating normally. Please consider to avoid location where quietness is required. For BC controller, it is recommended to be installed in places such as ceilings of corridor, rest rooms and plant rooms.

Measurement condition
PURY-P400, 450, 500YSLM-A1(-BS)

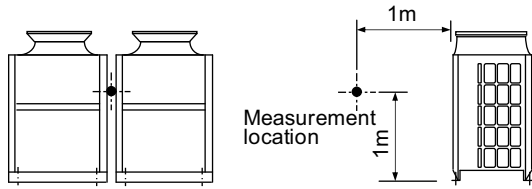

Sound level of PURY-P500YSLM-A1(-BS)

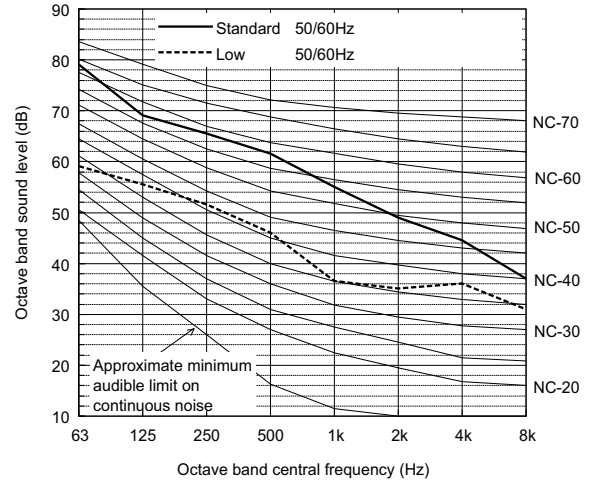

		63	125	250	500	1k	2k	4k	8k	dB(A)
Standard	50/60Hz	79.0	69.0	65.5	61.5	55.0	49.0	44.5	37.0	63.0
Low noise mode	50/60Hz	59.0	55.5	51.5	46.0	36.5	35.0	36.0	31.0	48.0

When Low noise mode is set, the A/C system's capacity is limited. The system could return to normal operation from Low noise mode automatically in the case that the operation condition is severe.

Sound level of PURY-P400YSLM-A1(-BS)

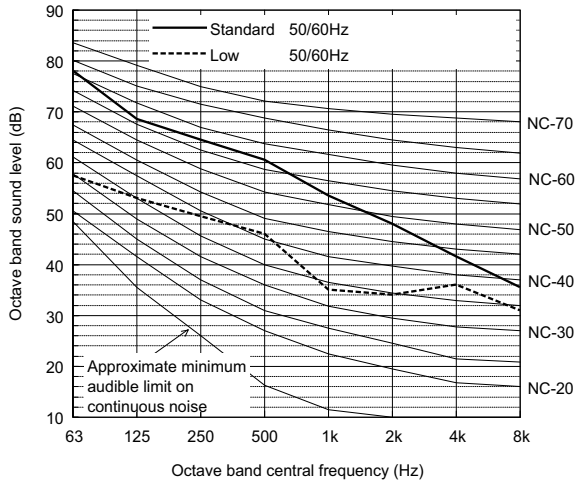

		63	125	250	500	1k	2k	4k	8k	dB(A)
Standard	50/60Hz	78.0	68.5	64.5	60.5	53.5	48.0	41.5	35.5	62.0
Low noise mode	50/60Hz	57.5	53.0	49.5	46.0	35.0	34.0	36.0	31.0	47.0

When Low noise mode is set, the A/C system's capacity is limited. The system could return to normal operation from Low noise mode automatically in the case that the operation condition is severe.

Sound level of PURY-P450YSLM-A1(-BS)

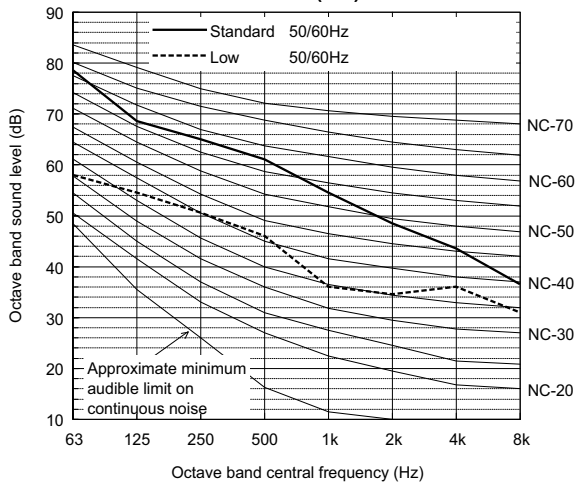

		63	125	250	500	1k	2k	4k	8k	dB(A)
Standard	50/60Hz	78.5	68.5	65.0	61.0	54.5	48.5	43.5	36.5	62.5
Low noise mode	50/60Hz	58.0	54.5	50.5	46.0	36.0	34.5	36.0	31.0	47.5

When Low noise mode is set, the A/C system's capacity is limited. The system could return to normal operation from Low noise mode automatically in the case that the operation condition is severe.

- Depending on the operation conditions, the unit generates noise caused by valve actuation, refrigerant flow, and pressure changes when operating normally. Please consider to avoid location where quietness is required. For BC controller, it is recommended to be installed in places such as ceilings of corridor, rest rooms and plant rooms.

R2

Measurement condition
PURY-P550YSLM-A1(-BS)

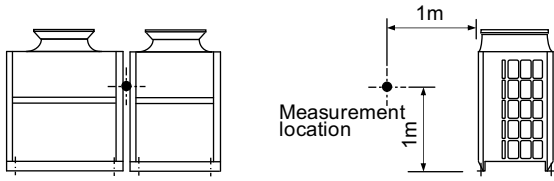

Measurement condition
PURY-P600, 650, 700, 750, 800YSLM-A1(-BS)

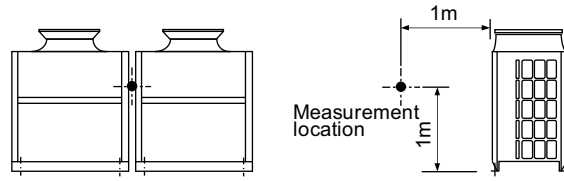

Sound level of PURY-P550YSLM-A1(-BS)

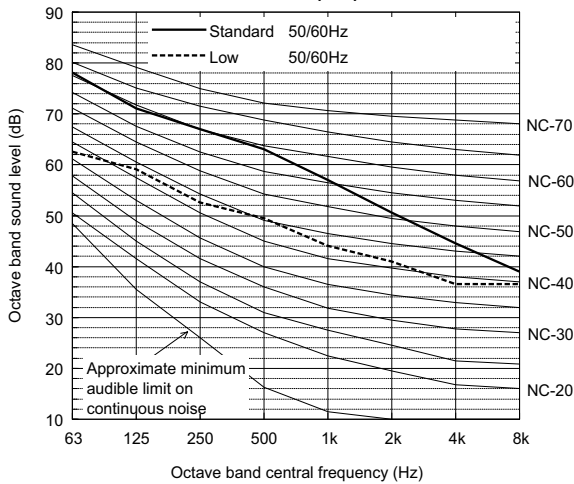

		63	125	250	500	1k	2k	4k	8k	dB(A)
Standard	50/60Hz	78.0	71.0	67.0	63.0	57.0	50.5	44.5	39.0	64.5
Low noise mode	50/60Hz	62.5	59.0	52.5	49.5	44.0	41.0	36.5	36.5	51.5

When Low noise mode is set, the A/C system's capacity is limited. The system could return to normal operation from Low noise mode automatically in the case that the operation condition is severe.

Sound level of PURY-P600YSLM-A1(-BS)

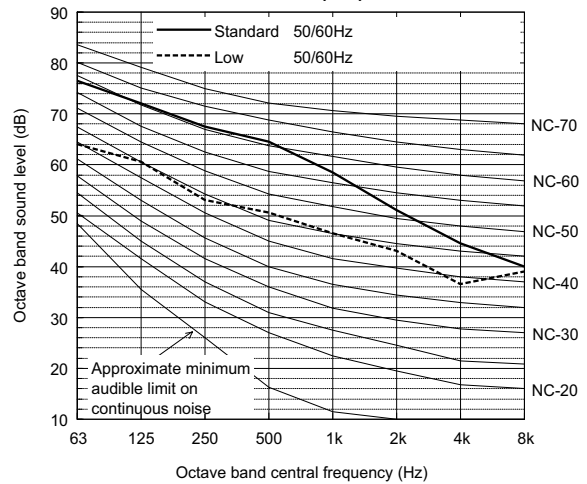

		63	125	250	500	1k	2k	4k	8k	dB(A)
Standard	50/60Hz	76.5	72.0	67.5	64.5	58.5	51.0	44.5	40.0	65.5
Low noise mode	50/60Hz	64.0	60.5	53.0	50.5	46.5	43.0	36.5	39.0	53.0

When Low noise mode is set, the A/C system's capacity is limited. The system could return to normal operation from Low noise mode automatically in the case that the operation condition is severe.

Sound level of PURY-P650YSLM-A1(-BS)

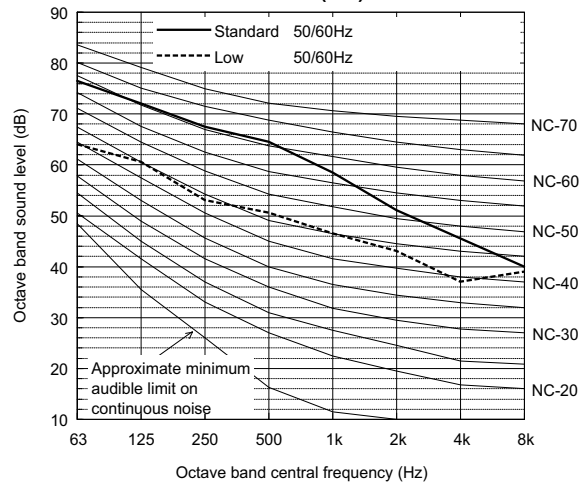

		63	125	250	500	1k	2k	4k	8k	dB(A)
Standard	50/60Hz	76.5	72.0	67.5	64.5	58.5	51.0	45.5	40.0	65.5
Low noise mode	50/60Hz	64.0	60.5	53.0	50.5	46.5	43.0	37.0	39.0	53.0

When Low noise mode is set, the A/C system's capacity is limited. The system could return to normal operation from Low noise mode automatically in the case that the operation condition is severe.

• Depending on the operation conditions, the unit generates noise caused by valve actuation, refrigerant flow, and pressure changes when operating normally. Please consider to avoid location where quietness is required. For BC controller, it is recommended to be installed in places such as ceilings of corridor, rest rooms and plant rooms.

Sound level of PURY-P700YSLM-A1(-BS)

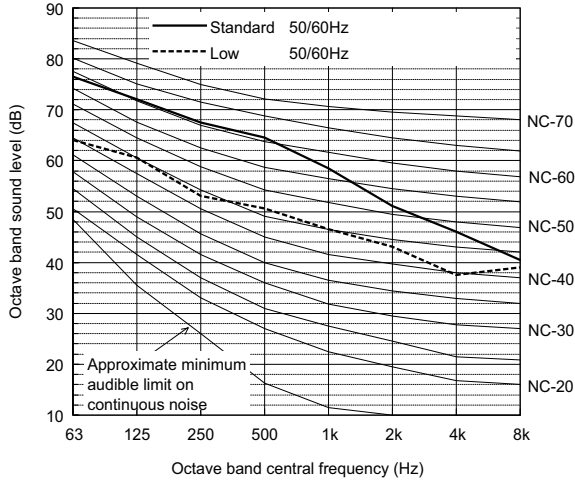

		63	125	250	500	1k	2k	4k	8k	dB(A)
Standard	50/60Hz	76.5	72.0	67.5	64.5	58.5	51.0	46.0	40.5	65.5
Low noise mode	50/60Hz	64.0	60.5	53.0	50.5	46.5	43.0	37.5	39.0	53.0

When Low noise mode is set, the A/C system's capacity is limited. The system could return to normal operation from Low noise mode automatically in the case that the operation condition is severe.

Measurement condition
PURY-P850YSLM-A1(-BS)

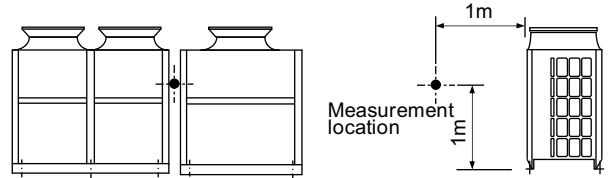

Sound level of PURY-P750YSLM-A1(-BS)

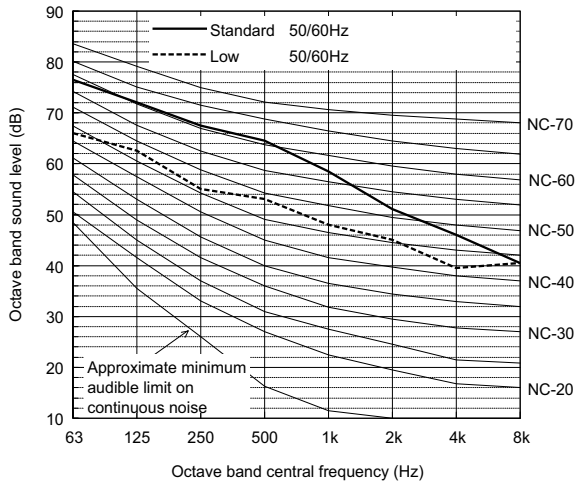

		63	125	250	500	1k	2k	4k	8k	dB(A)
Standard	50/60Hz	76.5	72.0	67.5	64.5	58.5	51.0	46.0	40.5	65.5
Low noise mode	50/60Hz	66.0	62.5	55.0	53.0	48.0	45.0	39.5	40.5	55.0

When Low noise mode is set, the A/C system's capacity is limited. The system could return to normal operation from Low noise mode automatically in the case that the operation condition is severe.

Sound level of PURY-P850YSLM-A1(-BS)

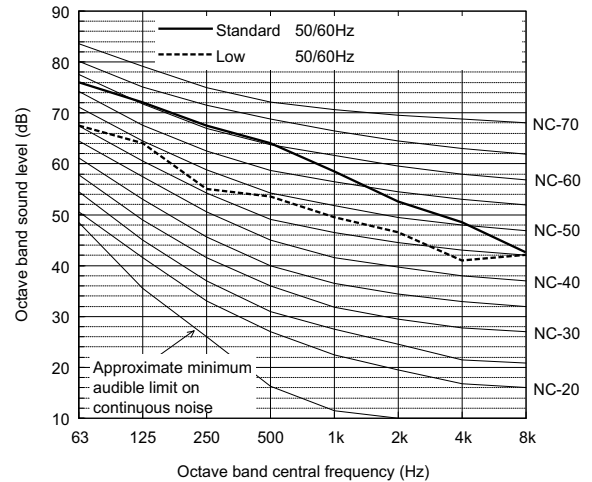

		63	125	250	500	1k	2k	4k	8k	dB(A)
Standard	50/60Hz	76.0	72.0	67.5	64.0	58.5	52.5	48.5	42.5	65.5
Low noise mode	50/60Hz	67.5	64.0	55.0	53.5	49.5	46.5	41.0	42.0	56.0

When Low noise mode is set, the A/C system's capacity is limited. The system could return to normal operation from Low noise mode automatically in the case that the operation condition is severe.

Sound level of PURY-P800YSLM-A1(-BS)

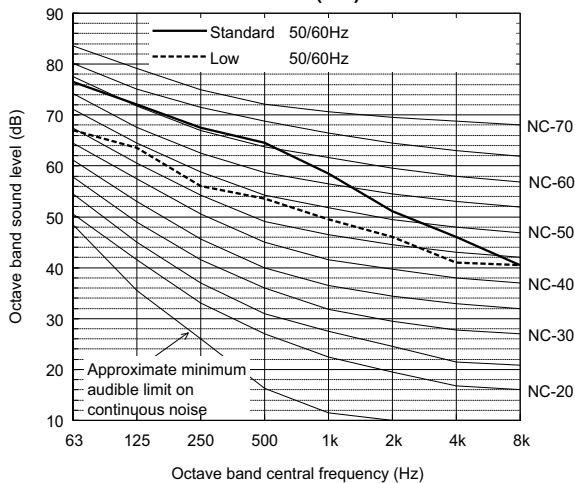

		63	125	250	500	1k	2k	4k	8k	dB(A)
Standard	50/60Hz	76.5	72.0	67.5	64.5	58.5	51.0	46.0	40.5	65.5
Low noise mode	50/60Hz	67.0	63.5	56.0	53.5	49.5	46.0	41.0	40.5	56.0

When Low noise mode is set, the A/C system's capacity is limited. The system could return to normal operation from Low noise mode automatically in the case that the operation condition is severe.

- Depending on the operation conditions, the unit generates noise caused by valve actuation, refrigerant flow, and pressure changes when operating normally. Please consider to avoid location where quietness is required. For BC controller, it is recommended to be installed in places such as ceilings of corridor, rest rooms and plant rooms.

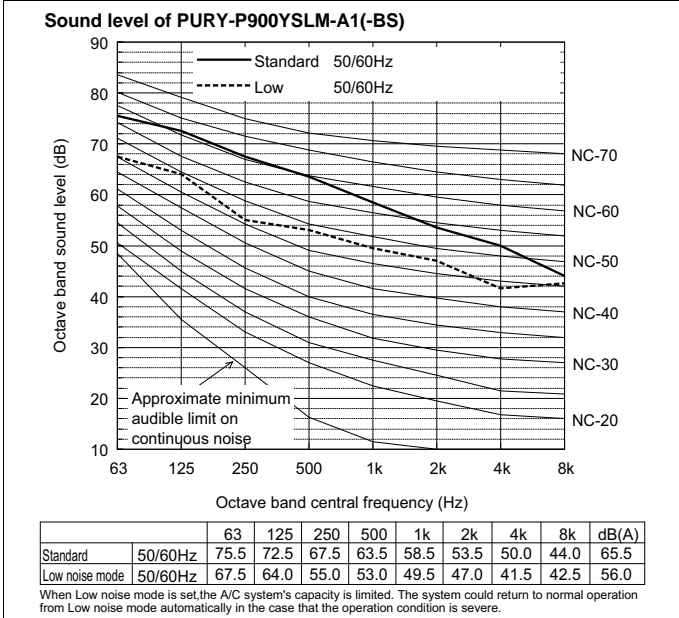
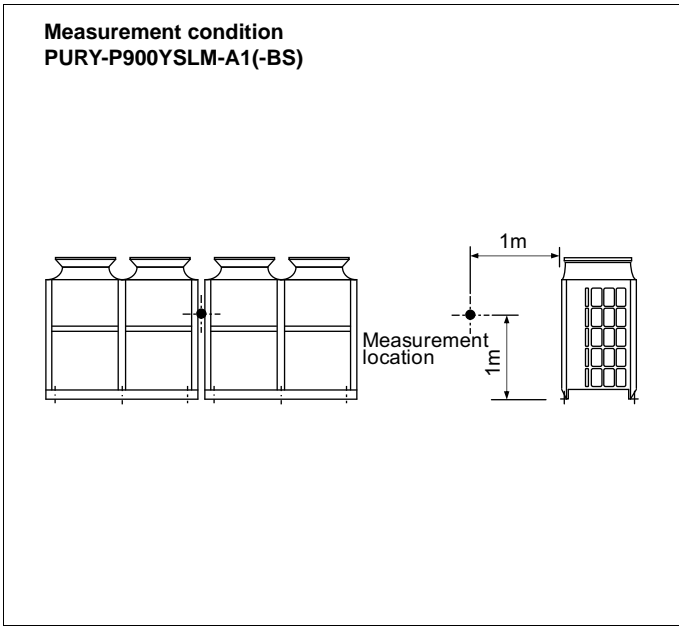

♦ Depending on the operation conditions, the unit generates noise caused by valve actuation, refrigerant flow, and pressure changes when operating normally. Please consider to avoid location where quietness is required. For BC controller, it is recommended to be installed in places such as ceilings of corridor, rest rooms and plant rooms.

[PURY-P200-500YLM, PURY-P400-900YSLM]

Measurement condition

Measurement frequency: 1 Hz-80 Hz

Measurement point: Ground surface 20 cm away from the unit leg

Installation condition: Direct installation on the concrete floor

Power source: 3-phase 4-wire 380-400-415 V 50/60 Hz

Operation condition: JIS condition (cooling, heating)

Measurement device: Vibration level meter for vibration pollution VM-1220C (JIS-compliant product)

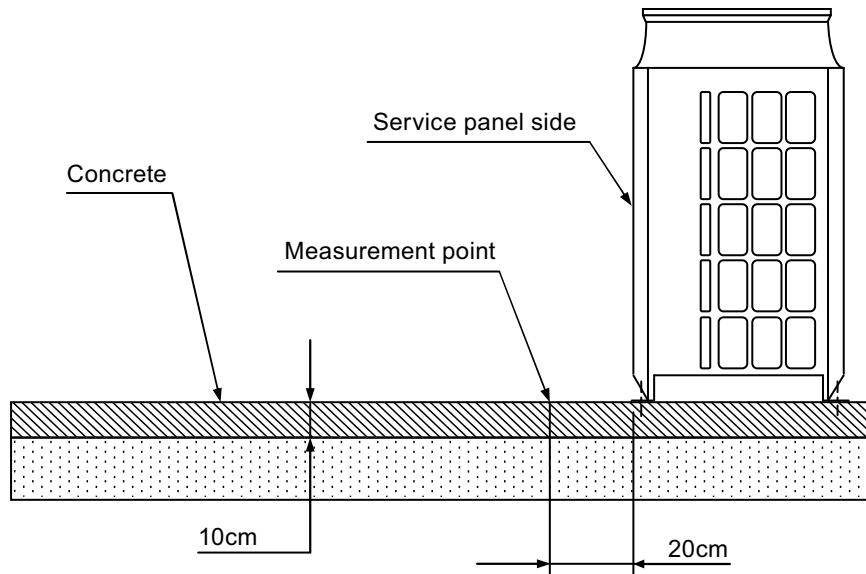

Vibration level

Model	Vibration level (dB)
PURY-P200YLM-A1 (-BS)	45
PURY-P250YLM-A1 (-BS)	46
PURY-P300YLM-A1 (-BS)	47
PURY-P350YLM-A1 (-BS)	47
PURY-P400YLM-A1 (-BS)	47
PURY-P450YLM-A1 (-BS)	47
PURY-P500YLM-A1 (-BS)	48
PURY-P400YSLM-A1 (-BS)	48
PURY-P450YSLM-A1 (-BS)	48.5
PURY-P500YSLM-A1 (-BS)	49
PURY-P550YSLM-A1 (-BS)	49.5
PURY-P600YSLM-A1 (-BS)	50
PURY-P650YSLM-A1 (-BS)	50
PURY-P700YSLM-A1 (-BS)	50
PURY-P750YSLM-A1 (-BS)	50
PURY-P800YSLM-A1 (-BS)	50
PURY-P850YSLM-A1 (-BS)	50
PURY-P900YSLM-A1 (-BS)	50

* Vibration level varies depending on the conditions of actual installation site.

R2

• Cooling only

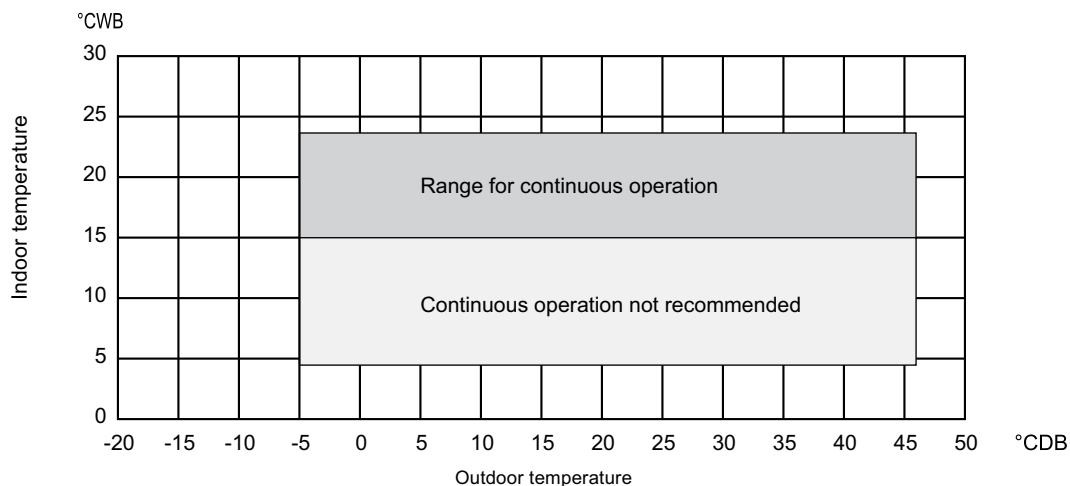

• Heating only

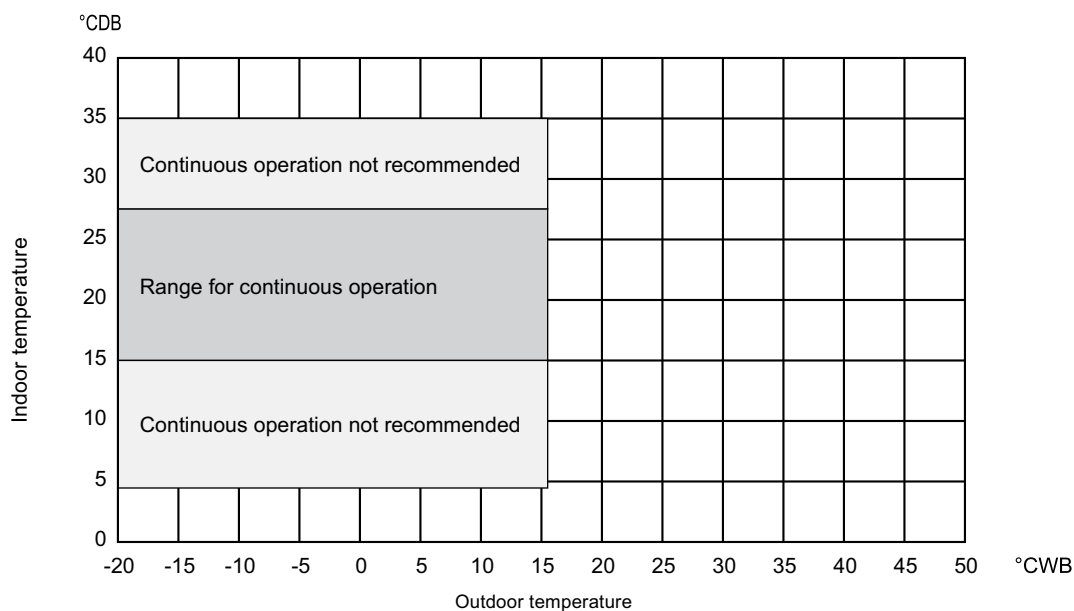

• Combination of cooling/heating operation (Cooling main or Heating main)

Outdoor temperature	Indoor temperature	
	Cooling	Heating
-10 to 21°CDB (14 to 70°FDB)	—	15 to 27°CDB (59 to 81°FDB)
-11 to 15.5°CWB (12.2 to 60°FWB)	15 to 24°CWB (59 to 75°FWB)	—

Section 8-1.

Shows an example of how to select the indoor and outdoor units according to the required heating/cooling load.

Section 8-2. through 8-6.

Show the actual correction data of indoor and outdoor units.

8-1. Selection of Cooling/Heating Units

<Cooling>

Design Condition	
Outdoor Design Dry Bulb Temperature	43 °C
Total Cooling Load	18.0 kW
Room1	
Indoor Design Dry Bulb Temperature	27 °C
Indoor Design Wet Bulb Temperature	20 °C
Cooling Load	8.0 kW
Room2	
Indoor Design Dry Bulb Temperature	24 °C
Indoor Design Wet Bulb Temperature	17 °C
Cooling Load	10.0 kW
<Other>	
Indoor/Outdoor Equivalent Piping Length	50 m

1. Cooling Calculation

(1) Temporary Selection of Indoor Units

Room1	PEFY-P80	9 kW (Rated)
Room2	PEFY-P100	11.2 kW (Rated)

(2) Total Indoor Units Capacity

$P80 + P100 = P180$

(3) Selection of Outdoor Unit

The P200 outdoor unit is selected as total indoor units capacity is P180

PUHY-P200	22.4 kW
-----------	---------

(4) Total Indoor Units Capacity Correction Calculation

Room1	Indoor Design Wet Bulb Temperature Correction (20°C)	1.04 (Refer to Fig.1)
Room2	Indoor Design Wet Bulb Temperature Correction (17°C)	0.95 (Refer to Fig.1)

Total Indoor Units Capacity (CTi)

$$CTi = \sum (\text{Indoor Unit Rating} \times \text{Indoor Design Temperature Correction})$$

$$= 9.0 \times 1.04 + 11.2 \times 0.95$$

$$= 20.0 \text{ kW}$$

(5) Outdoor Unit Correction Calculation

Outdoor Design Dry Bulb Temperature Correction (43°C)	0.94 (Refer to Fig.2)
Piping Length Correction (50 m)	0.94 (Refer to Fig.3)

Total Outdoor Unit Capacity (CTo)

$$CTo = \text{Outdoor Rating} \times \text{Outdoor Design Temperature Correction} \times \text{Piping Length Correction}$$

$$= 22.4 \times 0.94 \times 0.94$$

$$= 19.9 \text{ kW}$$

(6) Determination of Maximum System Capacity

Comparison of Capacity between Total Indoor Units Capacity (CTi) and Total Outdoor Unit Capacity (CTo)

$CTi = 20.0 > CTo = 19.9$, thus, select CTo.

$CTx = CTo = 19.9 \text{ kW}$

(7) Comparison with Essential Load

Against the essential load 18.0kW, the maximum system capacity is 19.9kW: Proper outdoor units have been selected.

(8) Calculation of Maximum Indoor Unit Capacity of Each Room

$CTx = CTo$, thus, calculate by the calculation below

Room1

$$\text{Maximum Capacity} \times \text{Room1 Capacity after the Temperature Correction} / (\text{Room1,2 Total Capacity after the Temperature Correction})$$

$$= 19.9 \times (9.0 \times 1.04) / (9.0 \times 1.04 + 11.2 \times 0.95)$$

$$= 9.3 \text{ kW} \quad \text{OK: fulfills the load 8.0kW}$$

Room2

$$\text{Maximum Capacity} \times \text{Room2 Capacity after the Temperature Correction} / (\text{Room1,2 Total Capacity after the Temperature Correction})$$

$$= 19.9 \times (11.2 \times 0.95) / (9.0 \times 1.04 + 11.2 \times 0.95)$$

$$= 10.6 \text{ kW} \quad \text{OK: fulfills the load 10.0kW}$$

Go on to the heating trial calculation since the selected units fulfill the cooling loads of Room 1, 2.

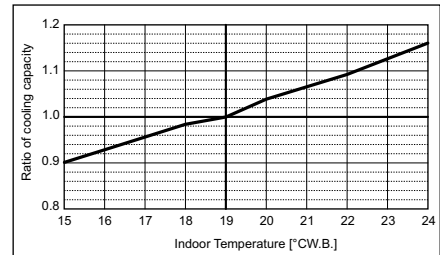

Fig.1 Indoor unit temperature correction
To be used to correct indoor unit only

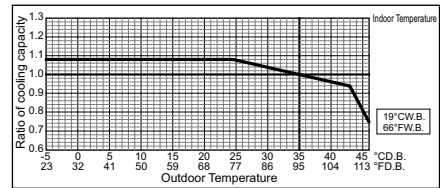

Fig.2 Outdoor unit temperature correction
To be used to correct outdoor unit only

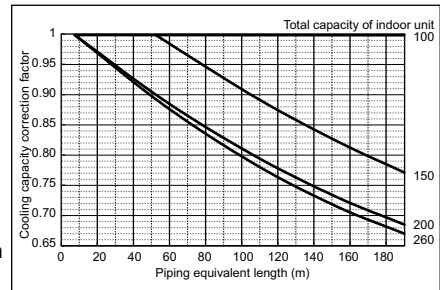

Fig.3 Correction of refrigerant piping length

<Heating>

Design Condition	
Outdoor Design Wet Bulb Temperature	-3 °C
Total Heating Load	20.5 kW
Room1	
Indoor Design Dry Bulb Temperature	21 °C
Heating Load	9.5 kW
Room2	
Indoor Design Dry Bulb Temperature	23 °C
Heating Load	11.0 kW
<Other>	
Indoor/Outdoor Equivalent Piping Length	50 m

2. Heating Calculation

(1) Temporary Selection of Indoor Units

Room1	PEFY-P80	10 kW (Rated)
Room2	PEFY-P100	12.5 kW (Rated)

(2) Total Indoor Units Capacity

P80 + P100 = P180

(3) Selection of Outdoor Unit

The P200 outdoor unit is selected as total indoor units capacity is P180

PUHY-P200	25.0 kW
-----------	---------

(4) Total Indoor Units Capacity Correction Calculation

Room1	Indoor Design Dry Bulb Temperature Correction (21°C)	0.97 (Refer to Fig.4)
Room2	Indoor Design Dry Bulb Temperature Correction (23°C)	0.90 (Refer to Fig.4)

Total Indoor Units Capacity (CTi)

$$CTi = \sum (\text{Indoor Unit Rating} \times \text{Indoor Design Temperature Correction})$$

$$= 10.0 \times 0.97 + 12.5 \times 0.90$$

$$= 21.0 \text{ kW}$$

(5) Outdoor Unit Correction Calculation

Outdoor Design Wet Bulb Temperature Correction (-3°C)	0.98 (Refer to Fig.5)
Piping Length Correction (50 m)	0.97 (Refer to Fig.6)
Defrost Correction	0.89 (Refer to Tbl.1)

Total Outdoor Unit Capacity (CTo)

$$CTo = \text{Outdoor Unit Rating} \times \text{Outdoor Design Temperature Correction} \times \text{Piping Length Correction} \times \text{Defrost Correction}$$

$$= 25.0 \times 0.98 \times 0.97 \times 0.89$$

$$= 21.1 \text{ kW}$$

(6) Determination of Maximum System Capacity

Comparison of Capacity between Total Indoor Units Capacity (CTi) and Total Outdoor Unit Capacity (CTo)

CTi = 21.0 < CTo = 21.1, thus, select CTi.

CTx = CTi = 21.0 kW

(7) Comparison with Essential Load

Against the essential load 20.5kW, the maximum system capacity is 21.0kW: Proper outdoor units have been selected.

(8) Calculation of Maximum Indoor Unit Capacity of Each Room

CTx = CTi, thus, calculate by the calculation below

Room1	Indoor Unit Rating × Indoor Design Temperature Correction	10.0 × 0.97	OK: fulfills the load 9.5kW
		= 9.7 kW	

Room2	Indoor Unit Rating × Indoor Design Temperature Correction	12.5 × 0.90	OK: fulfills the load 11.0kW
		= 11.3 kW	

Completed selecting units since the selected units fulfill the heating loads of Room 1, 2.

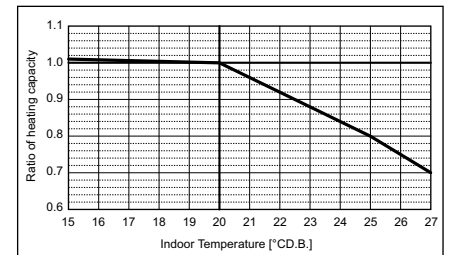

Fig.4 Indoor unit temperature correction
To be used to correct indoor unit only

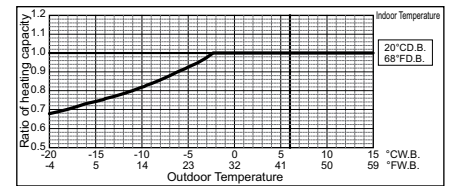

Fig.5 Outdoor unit temperature correction
To be used to correct outdoor unit only

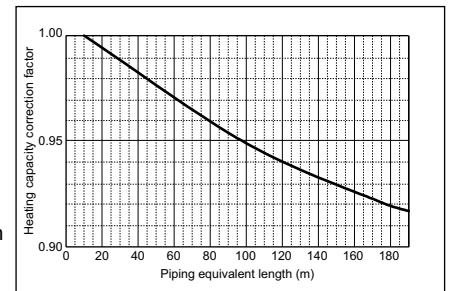

Fig.6 Correction of refrigerant piping length

Tbl.1 Table of correction factor at frost and defrost

Outdoor inlet air temp. °C	6	4	2	1	0	-2	-4	-6	-8	-10	-20
Outdoor inlet air temp. °F	43	39	36	34	32	28	25	21	18	14	-4
PUHY-P200	1.00	0.95	0.84	0.825	0.83	0.87	0.90	0.95	0.95	0.95	0.95
PUHY-P250	1.00	0.95	0.84	0.825	0.83	0.87	0.90	0.95	0.95	0.95	0.95
PUHY-P300	1.00	0.93	0.82	0.80	0.82	0.86	0.90	0.90	0.95	0.95	0.95
PUHY-P350	1.00	0.93	0.85	0.83	0.84	0.86	0.90	0.90	0.95	0.95	0.95
PUHY-P400	1.00	0.93	0.85	0.83	0.84	0.86	0.90	0.90	0.95	0.95	0.95

8-2. Correction by temperature

PURY-		P200YLM-A1	P250YLM-A1
Nominal Cooling Capacity	kW	22.4	28.0
	BTU/h	76,400	95,500
Input	kW	5.29	6.98

Indoor unit temperature correction
To be used to correct indoor unit capacity only

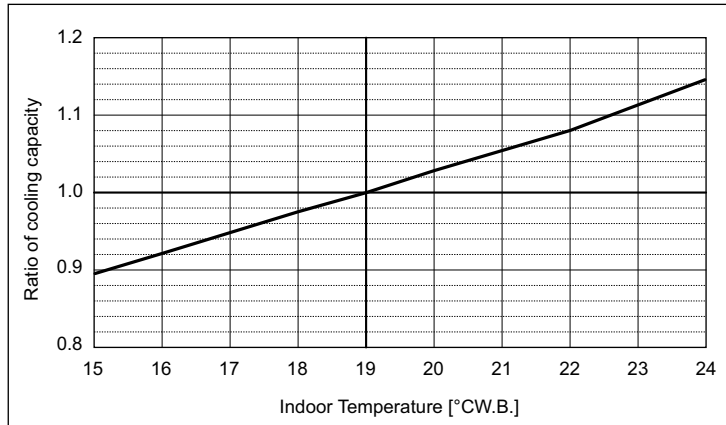

Outdoor unit temperature correction
To be used to correct outdoor unit only

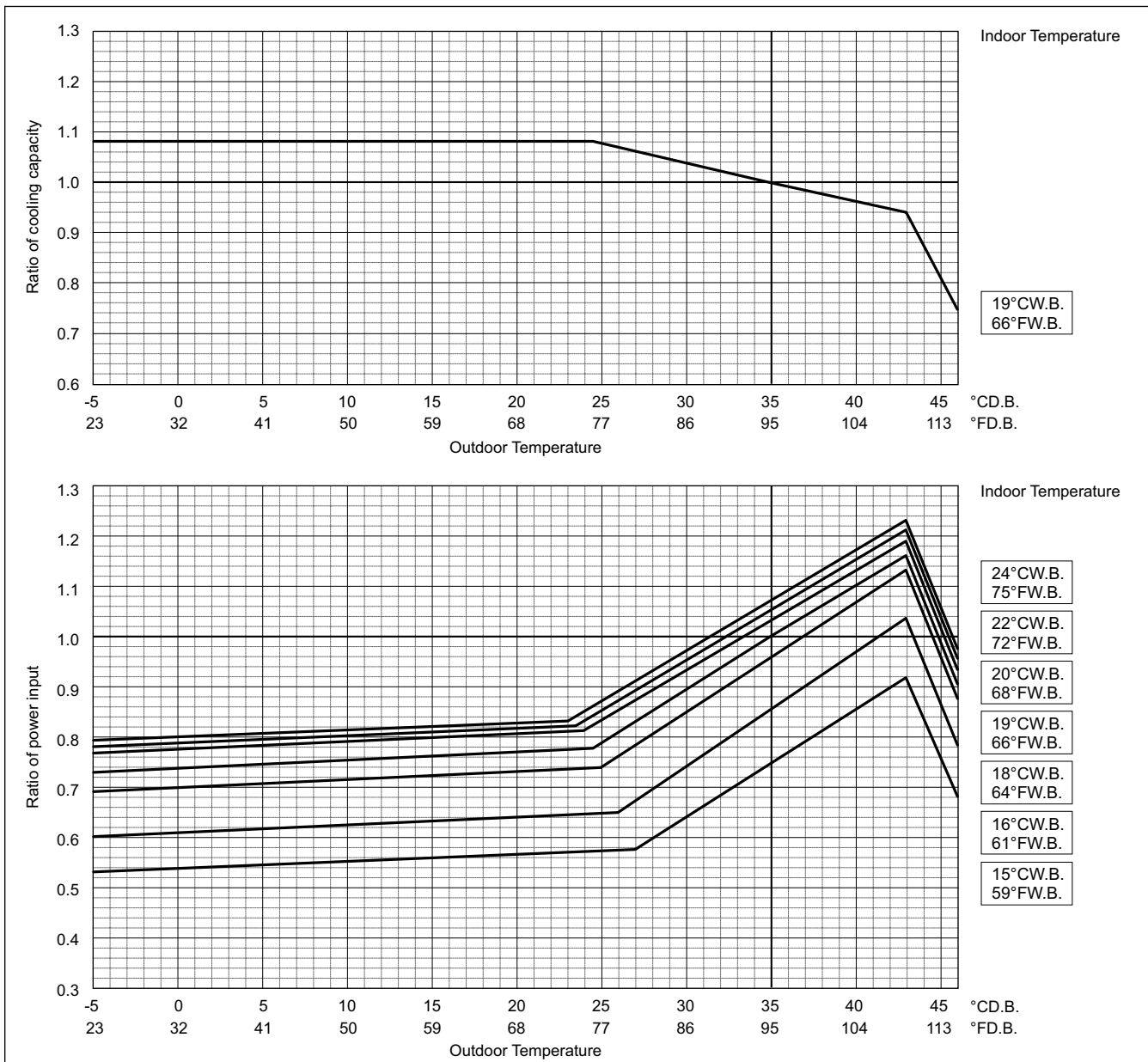

Outdoor unit power input is affected by the indoor and outdoor temperatures as shown in the graph above. Please consult the sales office for details.

R2

	PURY-	P200YLM-A1	P250YLM-A1
Nominal Heating Capacity	kW	25.0	31.5
	BTU/h	85,300	107,500
Input	kW	5.49	7.32

Indoor unit temperature correction
To be used to correct indoor unit capacity only

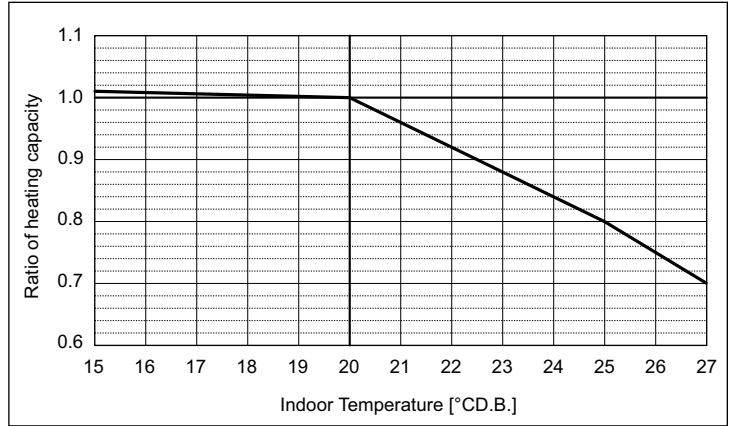

Outdoor unit temperature correction
To be used to correct outdoor unit only

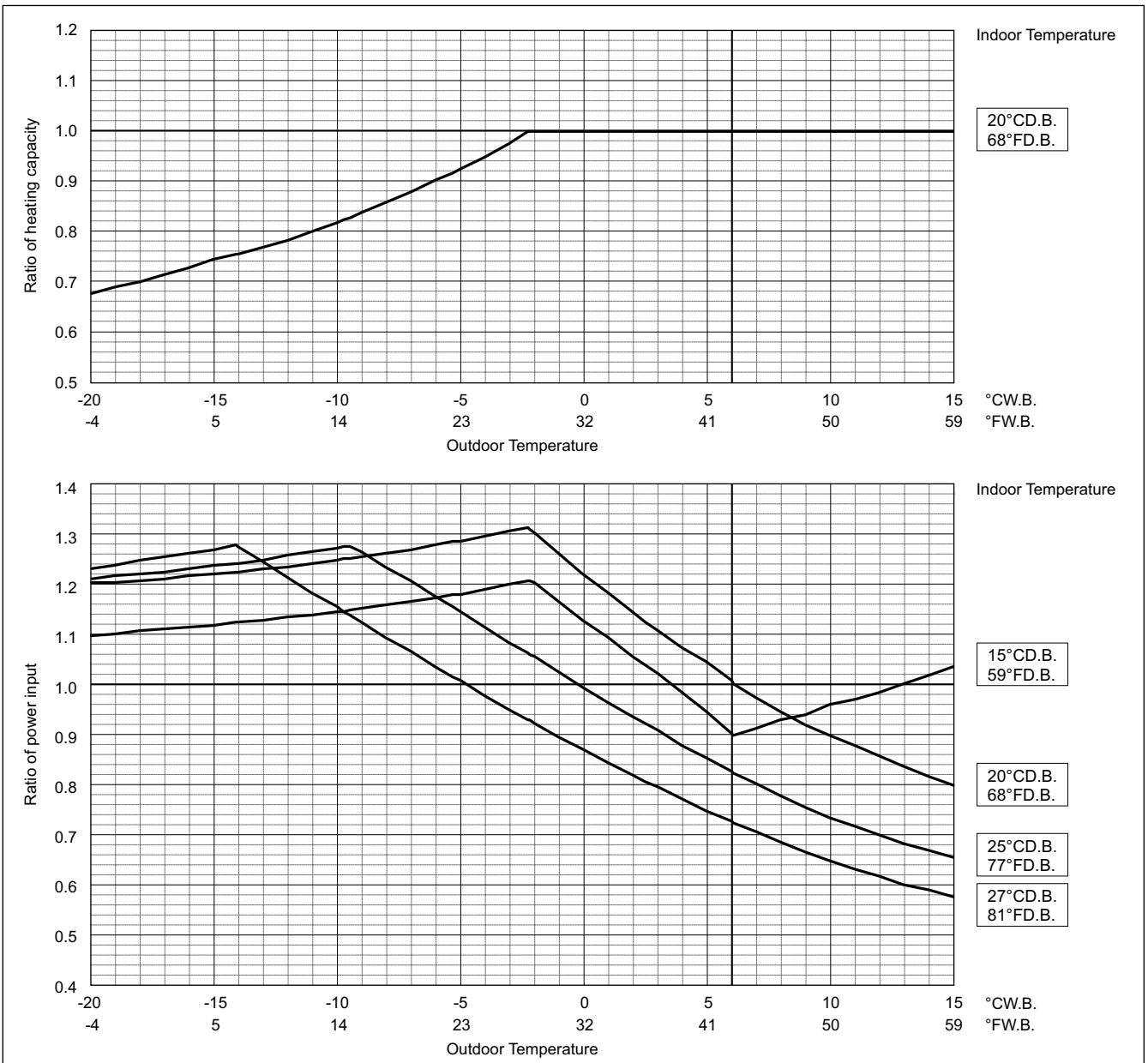

Outdoor unit power input is affected by the indoor and outdoor temperatures as shown in the graph above. Please consult the sales office for details.

R2

PURY-		P300YLM-A1	P350YLM-A1	P400YLM-A1
Nominal Cooling Capacity	kW	33.5	40.0	45.0
	BTU/h	114,300	136,500	153,500
Input	kW	9.10	11.76	13.71

PURY-		P400YSLM-A1
Nominal Cooling Capacity	kW	45.0
	BTU/h	153,500
Input	kW	10.97

Indoor unit temperature correction
To be used to correct indoor unit capacity only

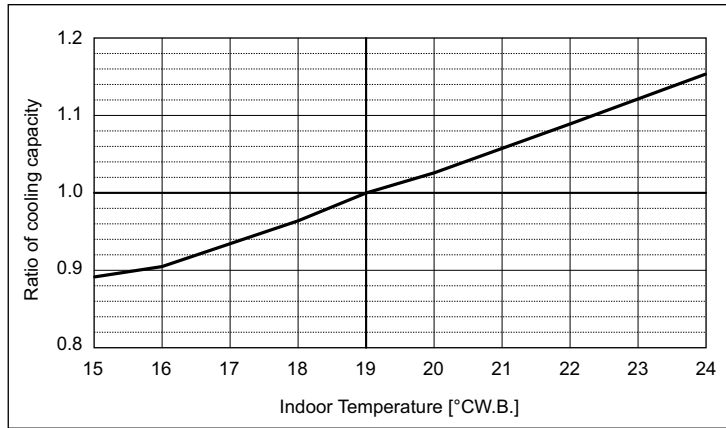

Outdoor unit temperature correction
To be used to correct outdoor unit only

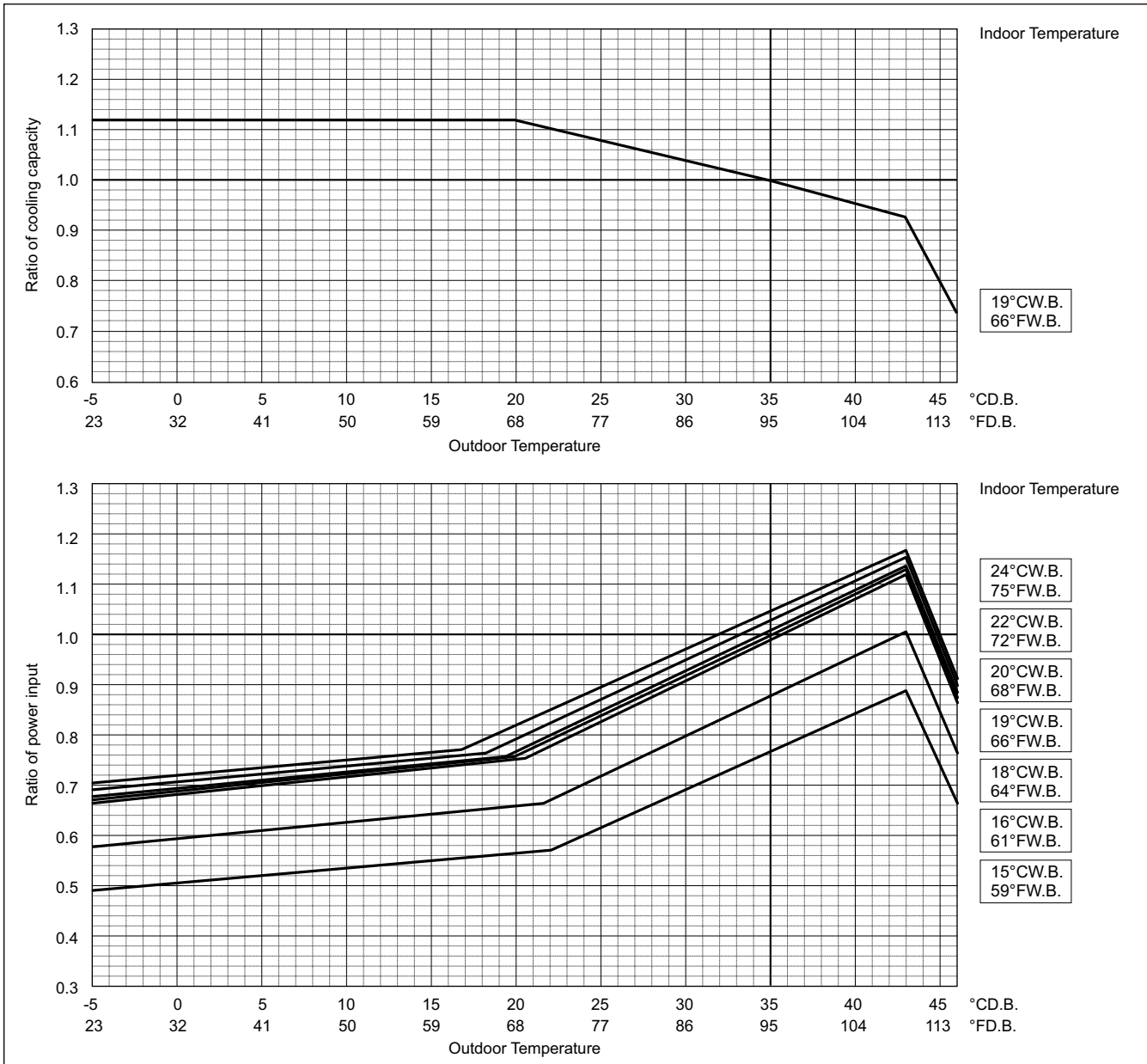

Outdoor unit power input is affected by the indoor and outdoor temperatures as shown in the graph above. Please consult the sales office for details.

PURY-		P300YLM-A1	P350YLM-A1	P400YLM-A1
Nominal Heating Capacity	kW	37.5	45.0	45.0
	BTU/h	128,000	153,500	153,500
Input	kW	9.37	11.59	11.42

PURY-		P400YSLM-A1
Nominal Heating Capacity	kW	50.0
	BTU/h	170,600
Input	kW	10.98

Indoor unit temperature correction
To be used to correct indoor unit capacity only

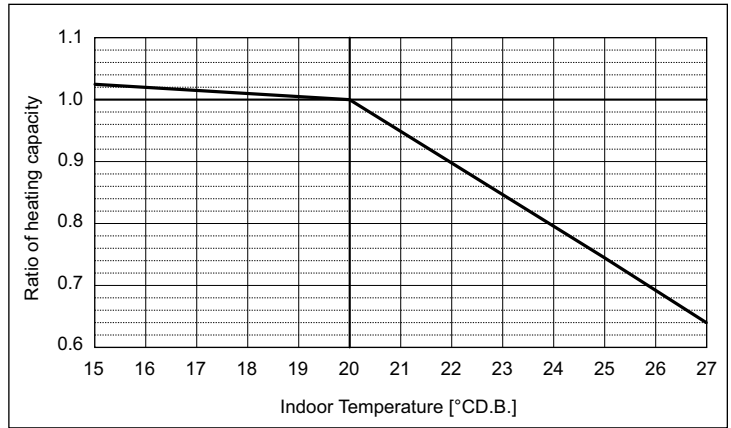

Outdoor unit temperature correction
To be used to correct outdoor unit only

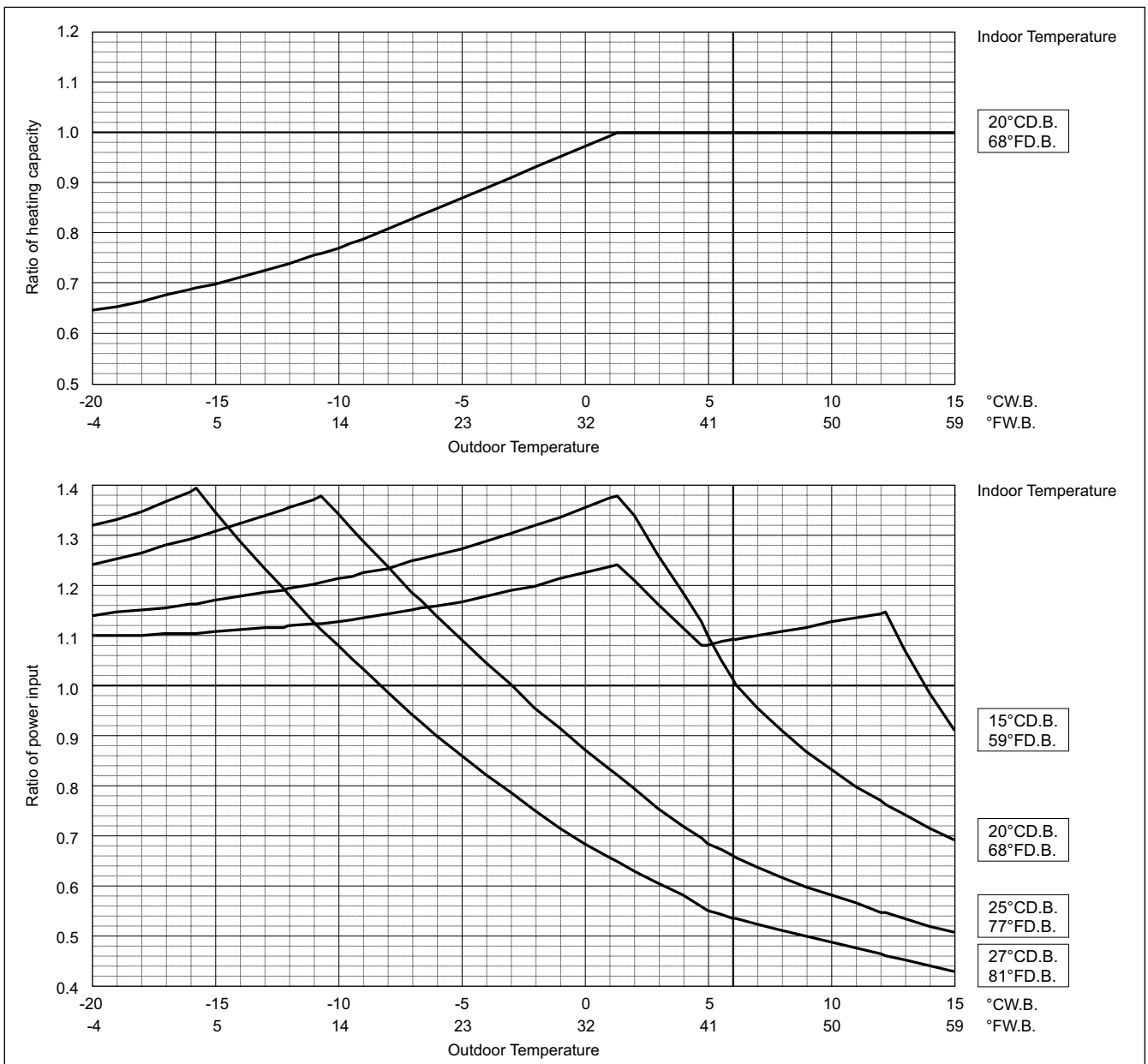

Outdoor unit power input is affected by the indoor and outdoor temperatures as shown in the graph above. Please consult the sales office for details.

8. CAPACITY TABLES

R2

PURY-		P450YLM-A1	P500YLM-A1	P450YSLM-A1
Nominal Cooling Capacity	kW	50.0	56.0	50.0
	BTU/h	170,600	191,100	170,600
Input	kW	14.32	17.77	12.50

PURY-		P500YSLM-A1	P550YSLM-A1	P600YSLM-A1
Nominal Cooling Capacity	kW	56.0	63.0	69.0
	BTU/h	191,100	215,000	235,400
Input	kW	14.39	16.89	19.32

PURY-		P650YSLM-A1
Nominal Cooling Capacity	kW	73.0
	BTU/h	249,100
Input	kW	21.28

Indoor unit temperature correction

To be used to correct indoor unit capacity only

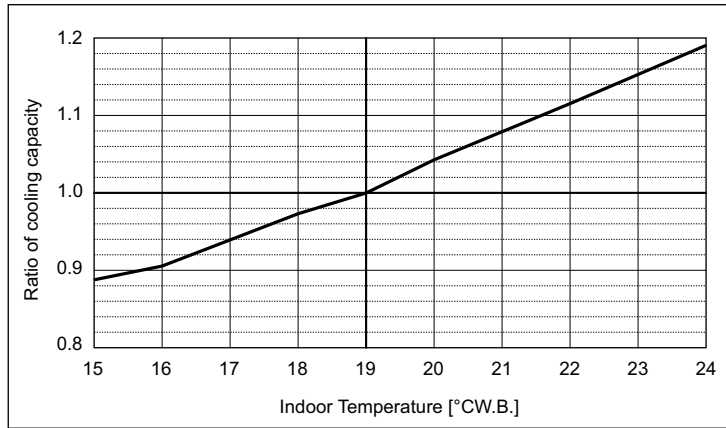

Outdoor unit temperature correction

To be used to correct outdoor unit only

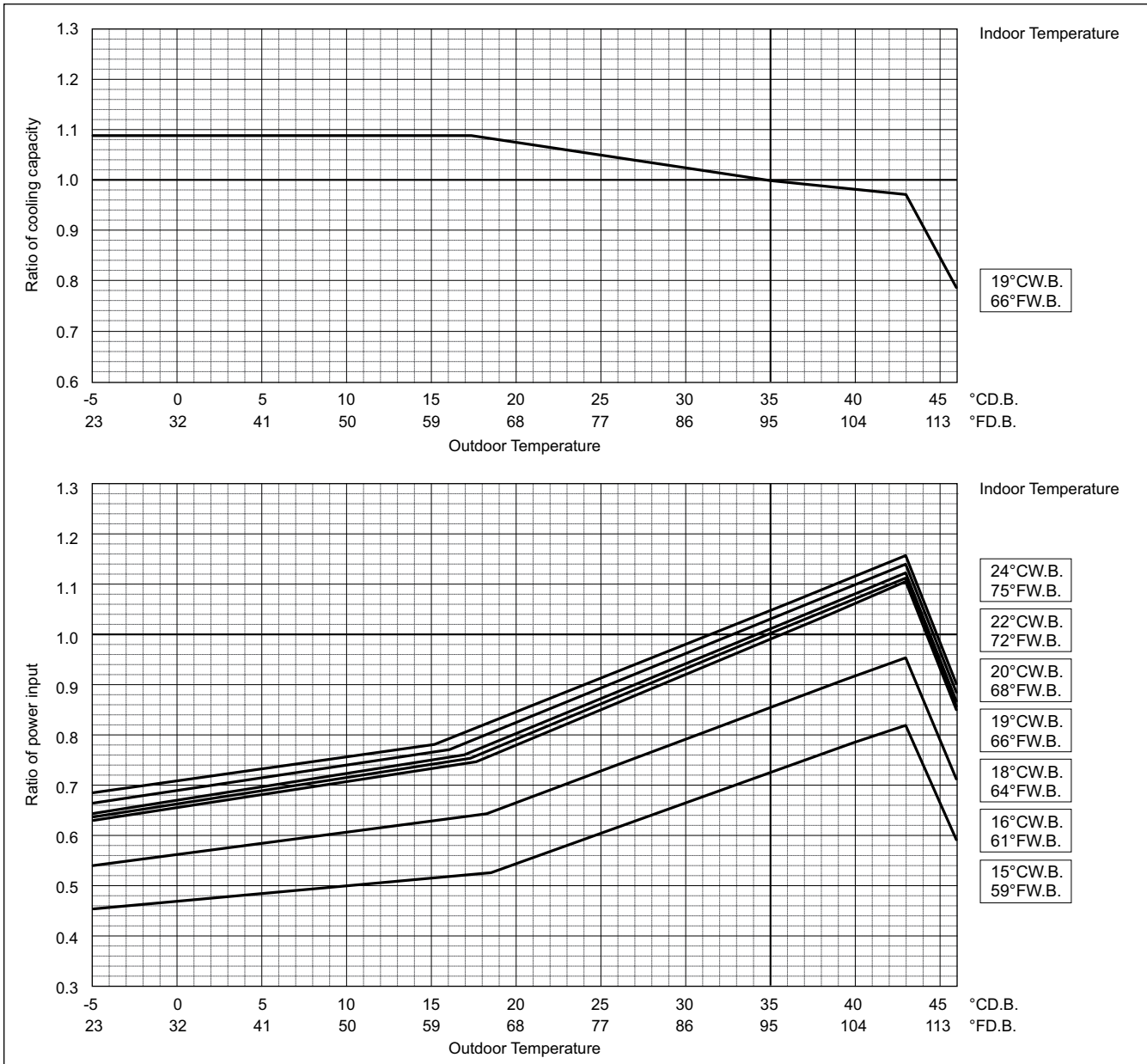

Outdoor unit power input is affected by the indoor and outdoor temperatures as shown in the graph above. Please consult the sales office for details.

8. CAPACITY TABLES

PURY-		P450YLM-A1	P500YLM-A1	P450YSLM-A1
Nominal Heating Capacity	kW	56.0	58.0	56.0
	BTU/h	191,100	197,900	191,100
Input	kW	14.93	16.06	12.64

PURY-		P500YSLM-A1	P550YSLM-A1	P600YSLM-A1
Nominal Heating Capacity	kW	63.0	69.0	76.5
	BTU/h	215,000	235,400	261,000
Input	kW	14.65	16.62	19.12

PURY-		P650YSLM-A1
Nominal Heating Capacity	kW	81.5
	BTU/h	278,100
Input	kW	20.68

Indoor unit temperature correction
To be used to correct indoor unit capacity only

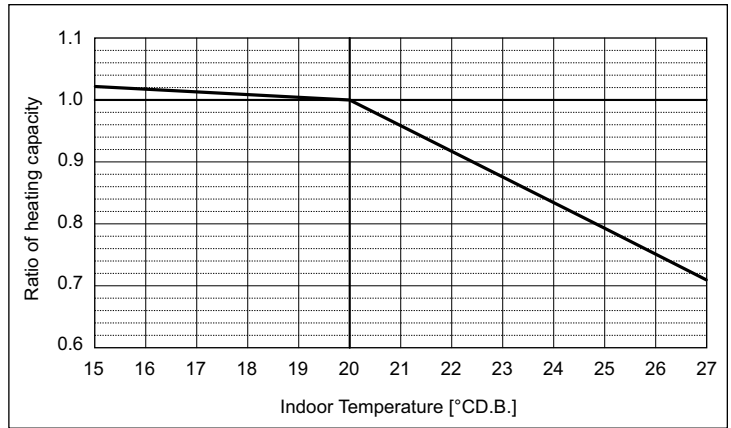

Outdoor unit temperature correction
To be used to correct outdoor unit only

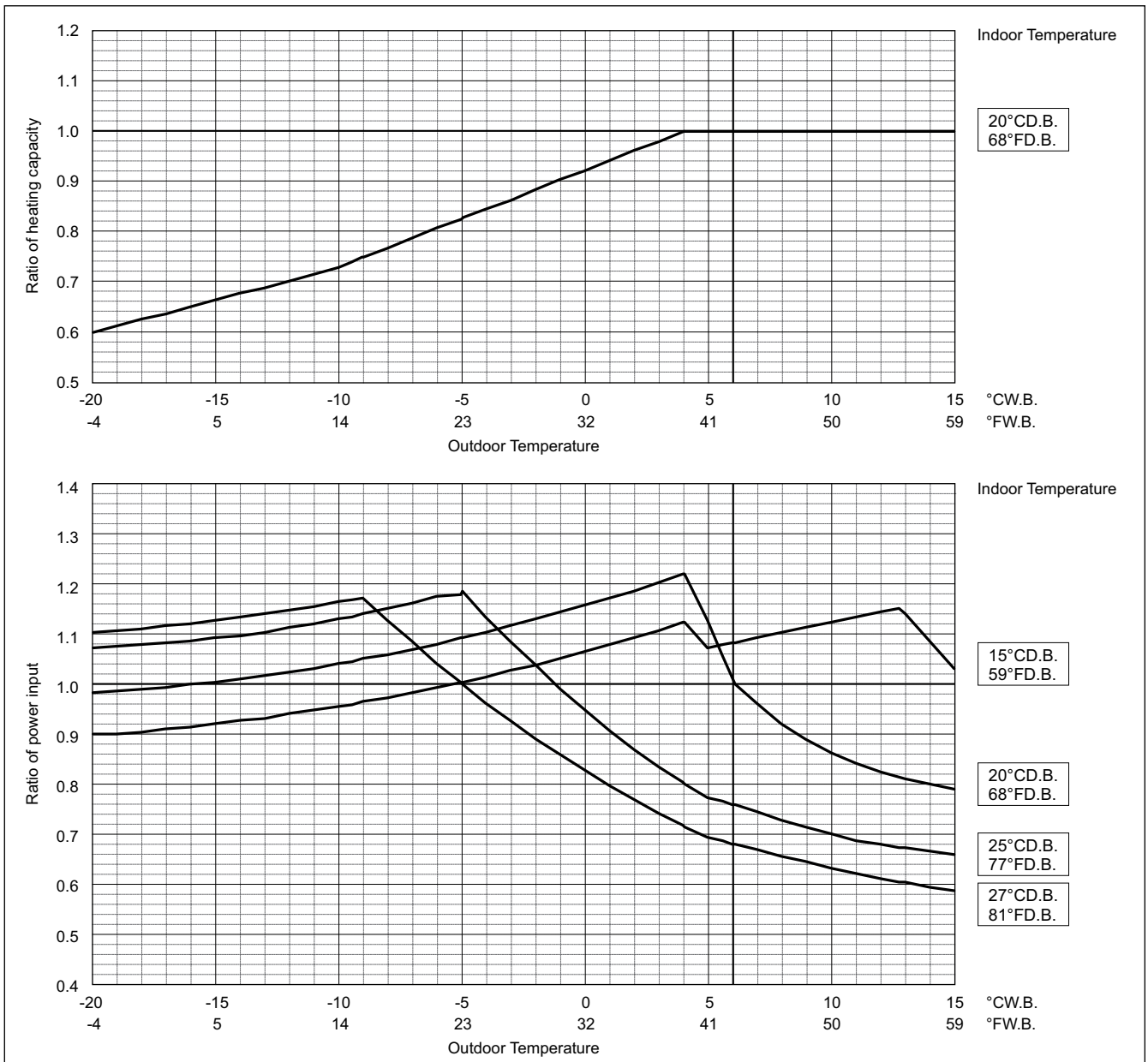

Outdoor unit power input is affected by the indoor and outdoor temperatures as shown in the graph above. Please consult the sales office for details.

PURY-		P700YSLM-A1	P750YSLM-A1	P800YSLM-A1
Nominal Cooling Capacity	kW	80.0	85.0	90.0
	BTU/h	273,000	290,000	307,100
Input	kW	24.24	26.23	28.30

Indoor unit temperature correction

To be used to correct indoor unit capacity only

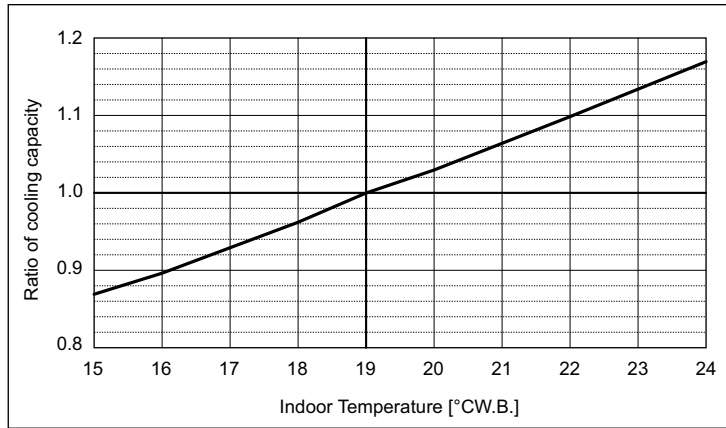

Outdoor unit temperature correction

To be used to correct outdoor unit only

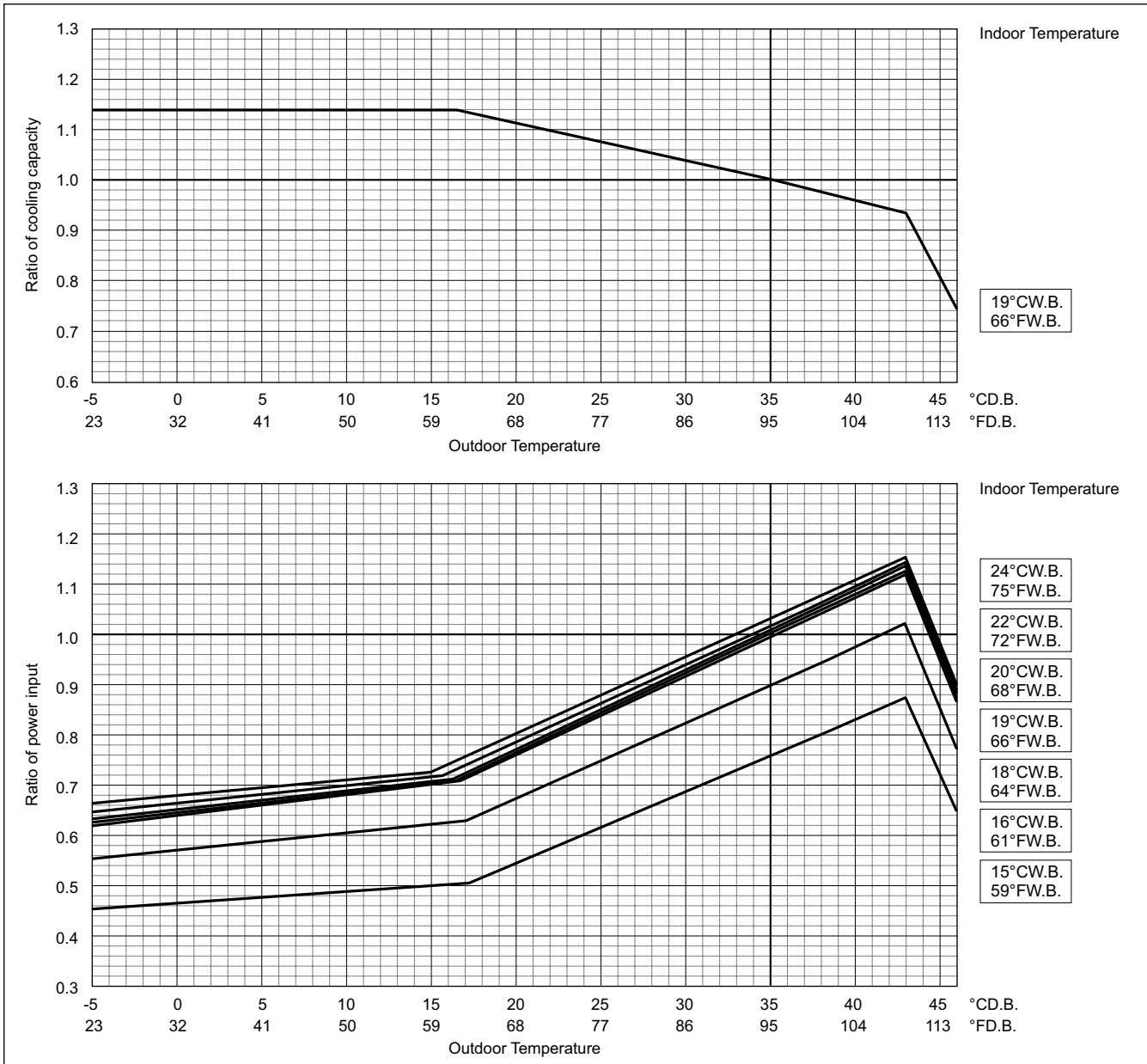

Outdoor unit power input is affected by the indoor and outdoor temperatures as shown in the graph above. Please consult the sales office for details.

PURY-		P700YSLM-A1	P750YSLM-A1	P800YSLM-A1
Nominal Heating Capacity	kW	88.0	90.0	90.0
	BTU/h	300,300	307,100	307,100
Input	kW	22.68	23.01	22.84

Indoor unit temperature correction

To be used to correct indoor unit capacity only

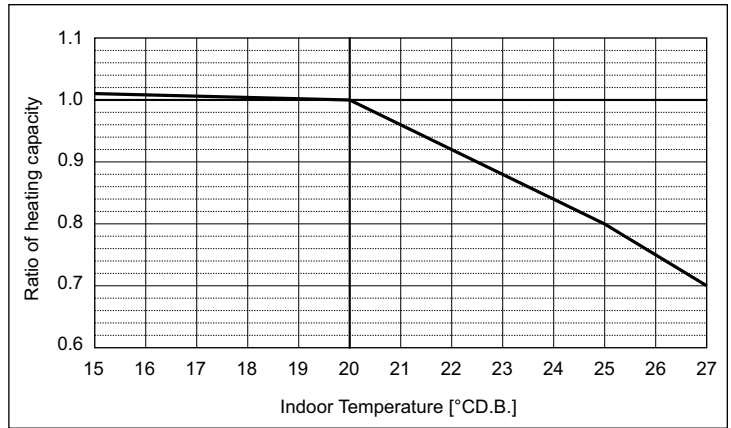

Outdoor unit temperature correction

To be used to correct outdoor unit only

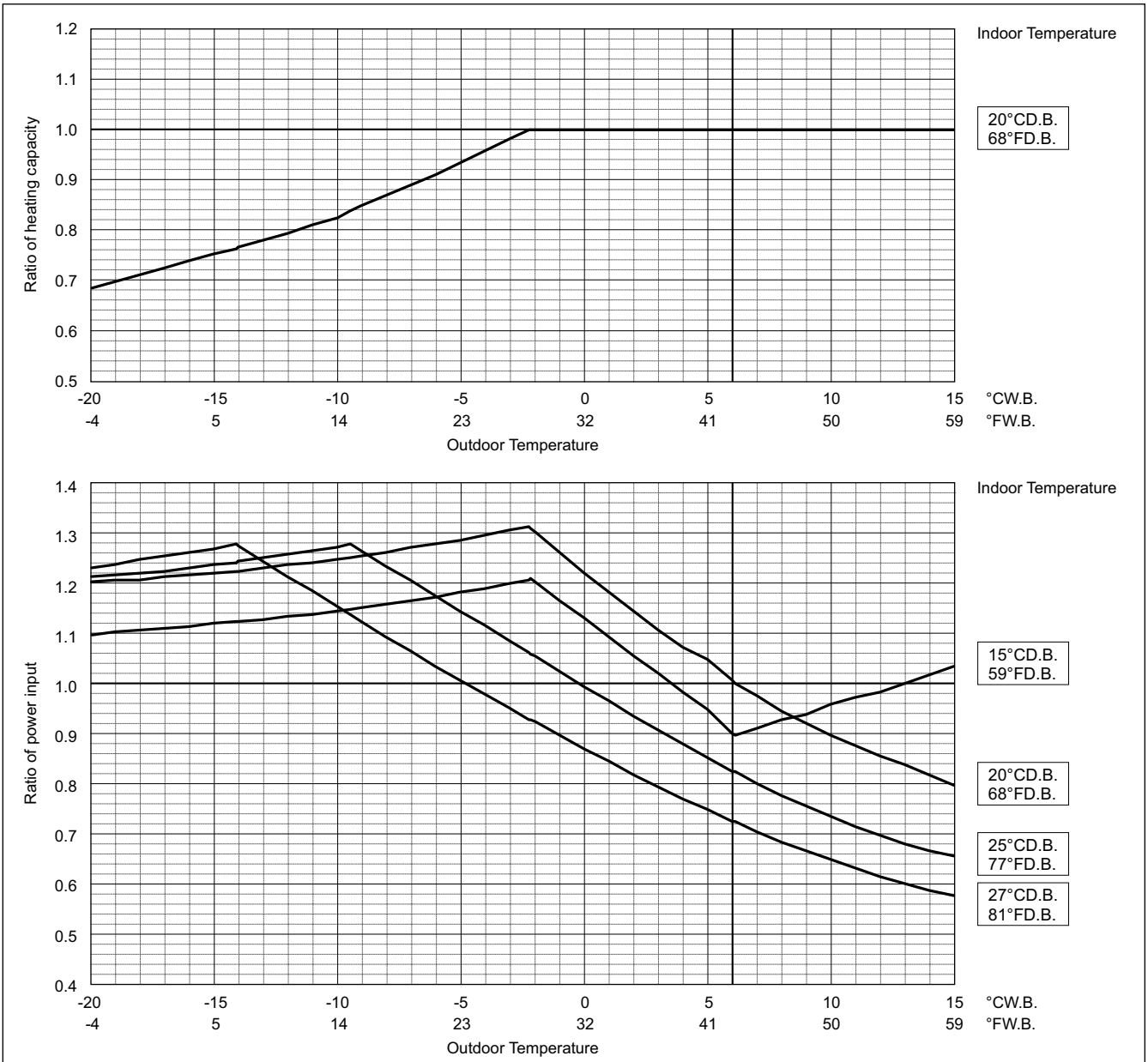

Outdoor unit power input is affected by the indoor and outdoor temperatures as shown in the graph above. Please consult the sales office for details.

R2

PURY-		P850YSLM-A1	P900YSLM-A1
Nominal Cooling Capacity	kW	96.0	101.0
	BTU/h	327,600	344,600
Input	kW	29.26	29.79

Indoor unit temperature correction

To be used to correct indoor unit capacity only

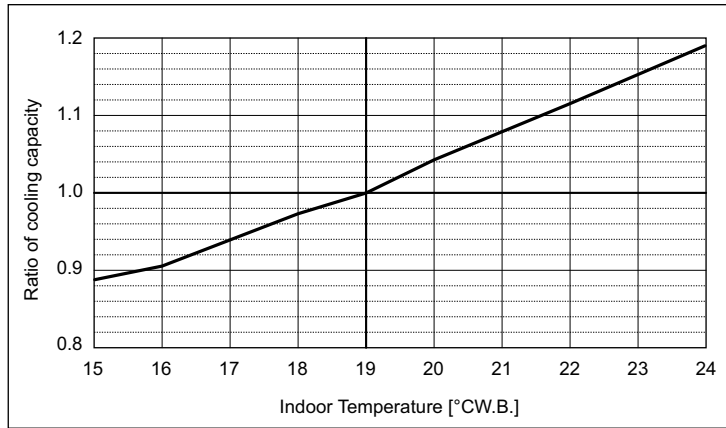

Outdoor unit temperature correction

To be used to correct outdoor unit only

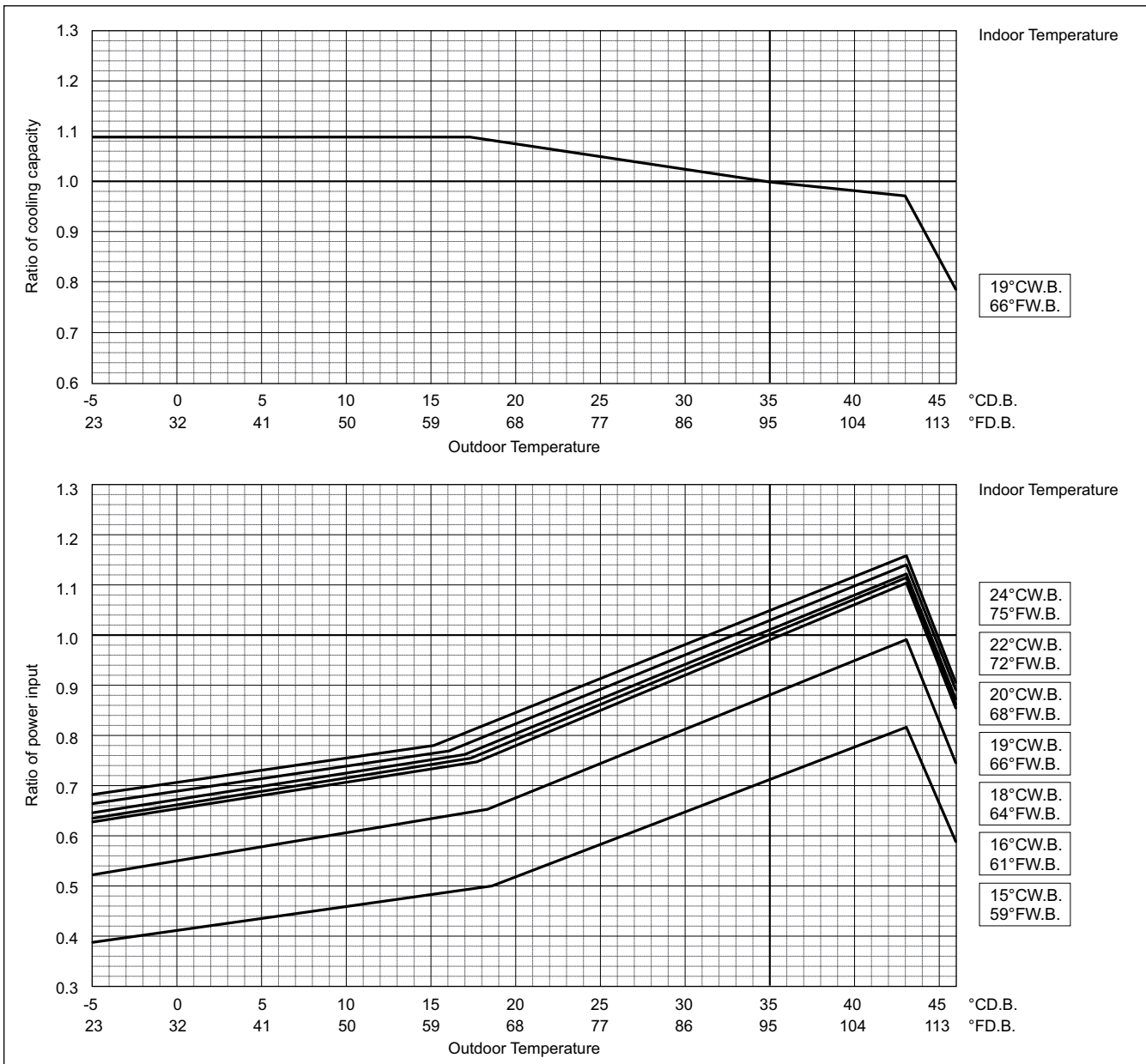

Outdoor unit power input is affected by the indoor and outdoor temperatures as shown in the graph above. Please consult the sales office for details.

R2

PURY-	P850YSLM-A1	P900YSLM-A1
Nominal Heating Capacity	kW 101.0	113.0
	BTU/h 344,600	385,600
Input	kW 26.23	30.13

Indoor unit temperature correction

To be used to correct indoor unit capacity only

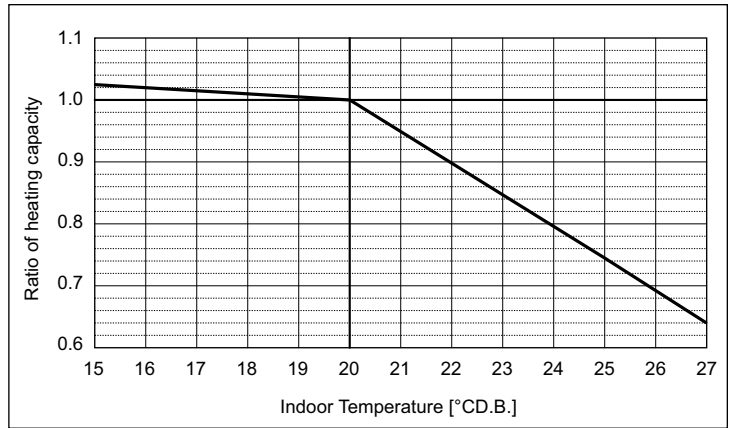

Outdoor unit temperature correction

To be used to correct outdoor unit only

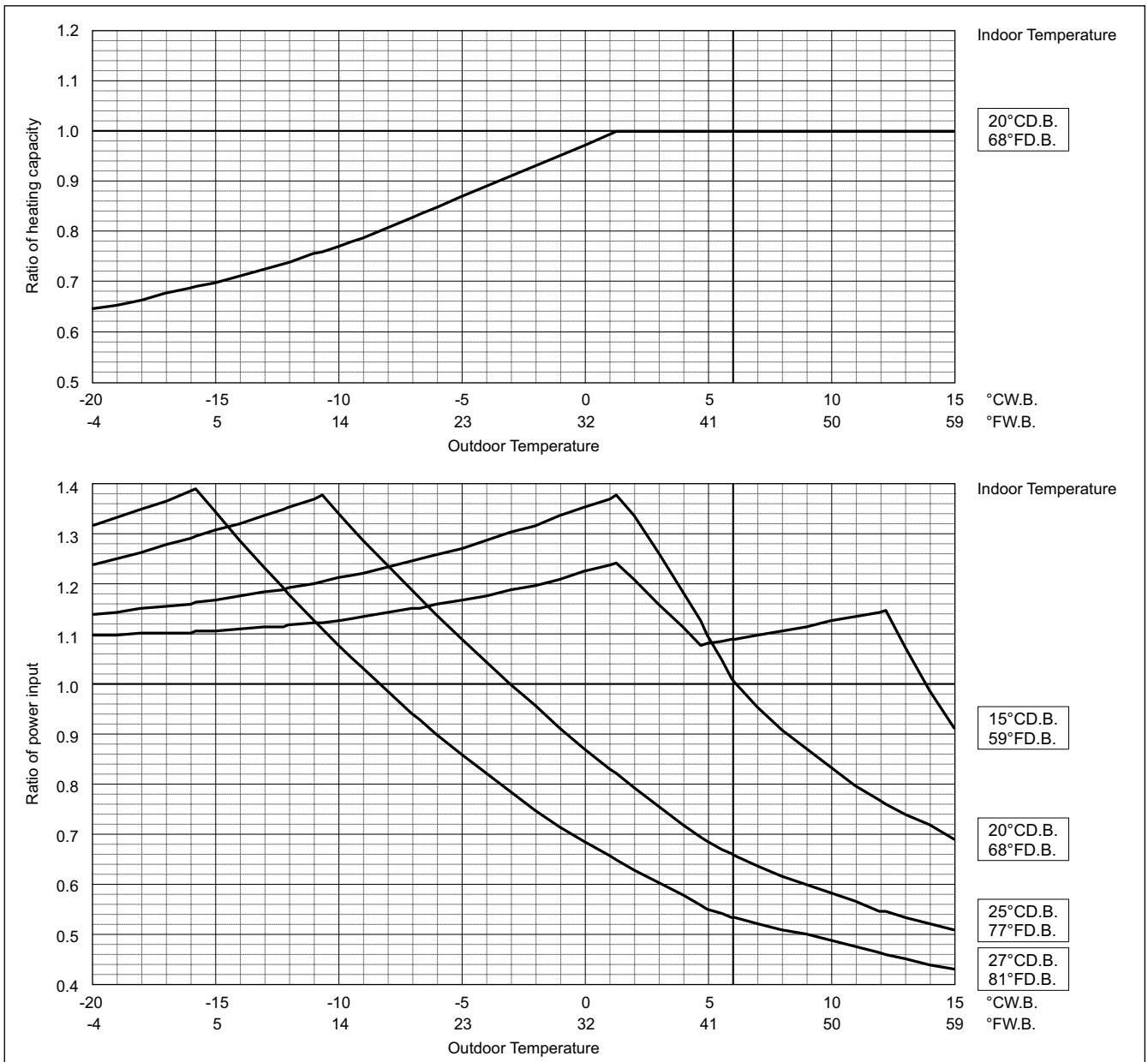

Outdoor unit power input is affected by the indoor and outdoor temperatures as shown in the graph above. Please consult the sales office for details.

R2

Correction by temperature (COP Priority Mode)

CITY MULTI could have various capacities at different designing temperatures. Using the nominal cooling/heating capacity values and the ratios below, the capacity can be found for various temperatures. To select COP priority mode, DipSW 6-2 must be set to ON.

PURY-	P200YLM-A1	P250YLM-A1
Nominal Cooling Capacity	22.4	28.0
Input	5.29	6.98

Indoor unit temperature correction

To be used to correct indoor unit capacity only

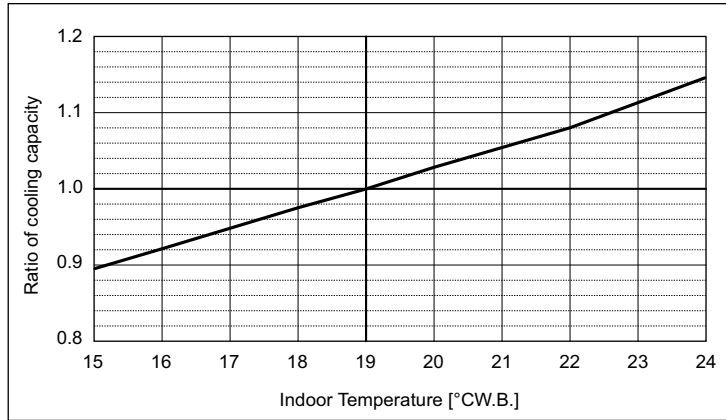

Outdoor unit temperature correction

To be used to correct outdoor unit only

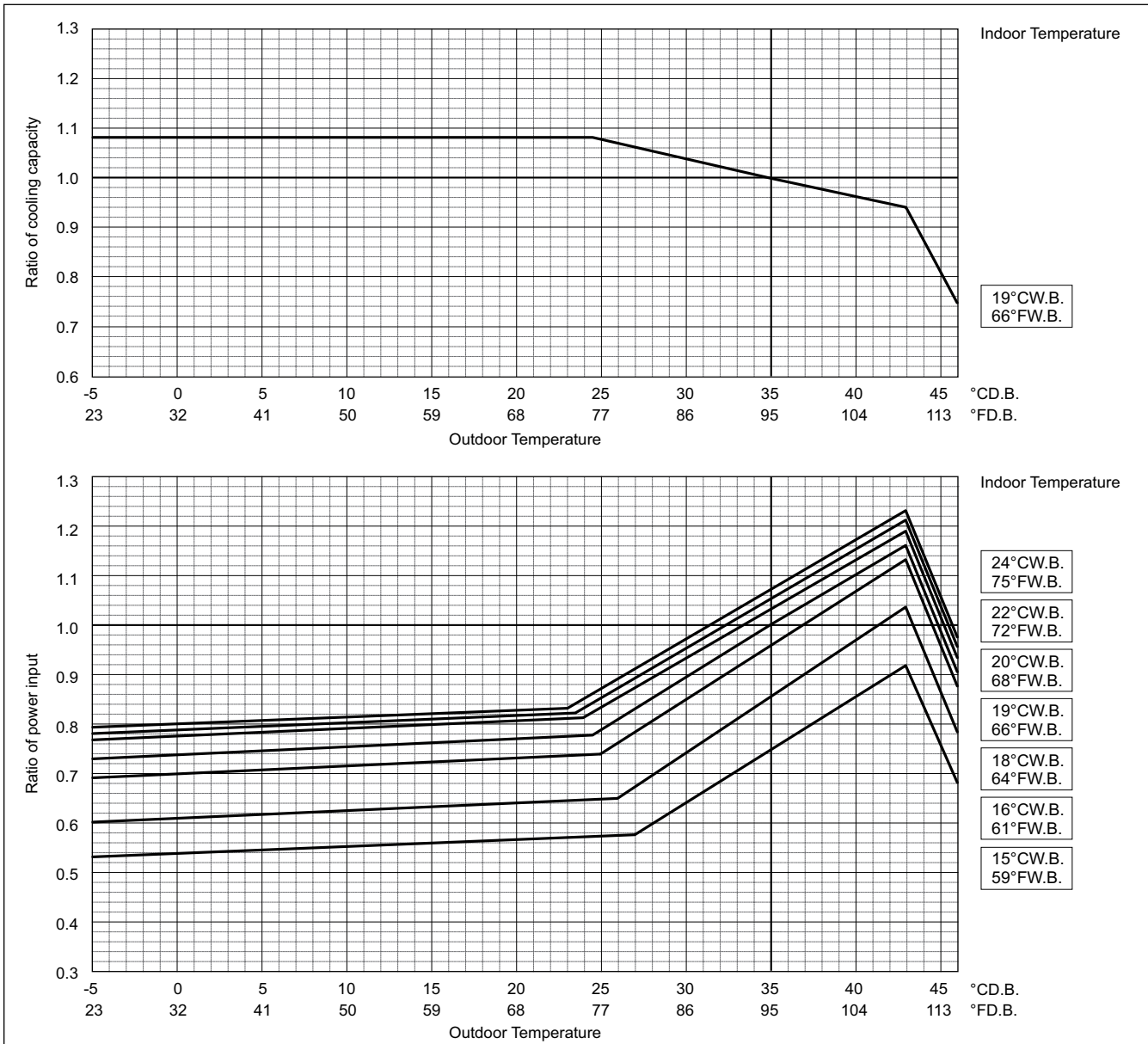

Outdoor unit power input is affected by the indoor and outdoor temperatures as shown in the graph above. Please consult the sales office for details.

	PURY-	P200YLM-A1	P250YLM-A1
Nominal Heating Capacity	kW	25.0	31.5
	BTU/h	85,300	107,500
Input	kW	5.49	7.32

Indoor unit temperature correction

To be used to correct indoor unit capacity only

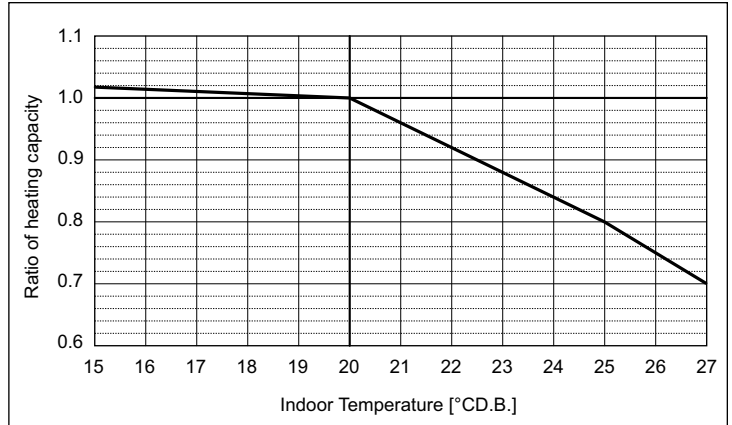

Outdoor unit temperature correction

To be used to correct outdoor unit only

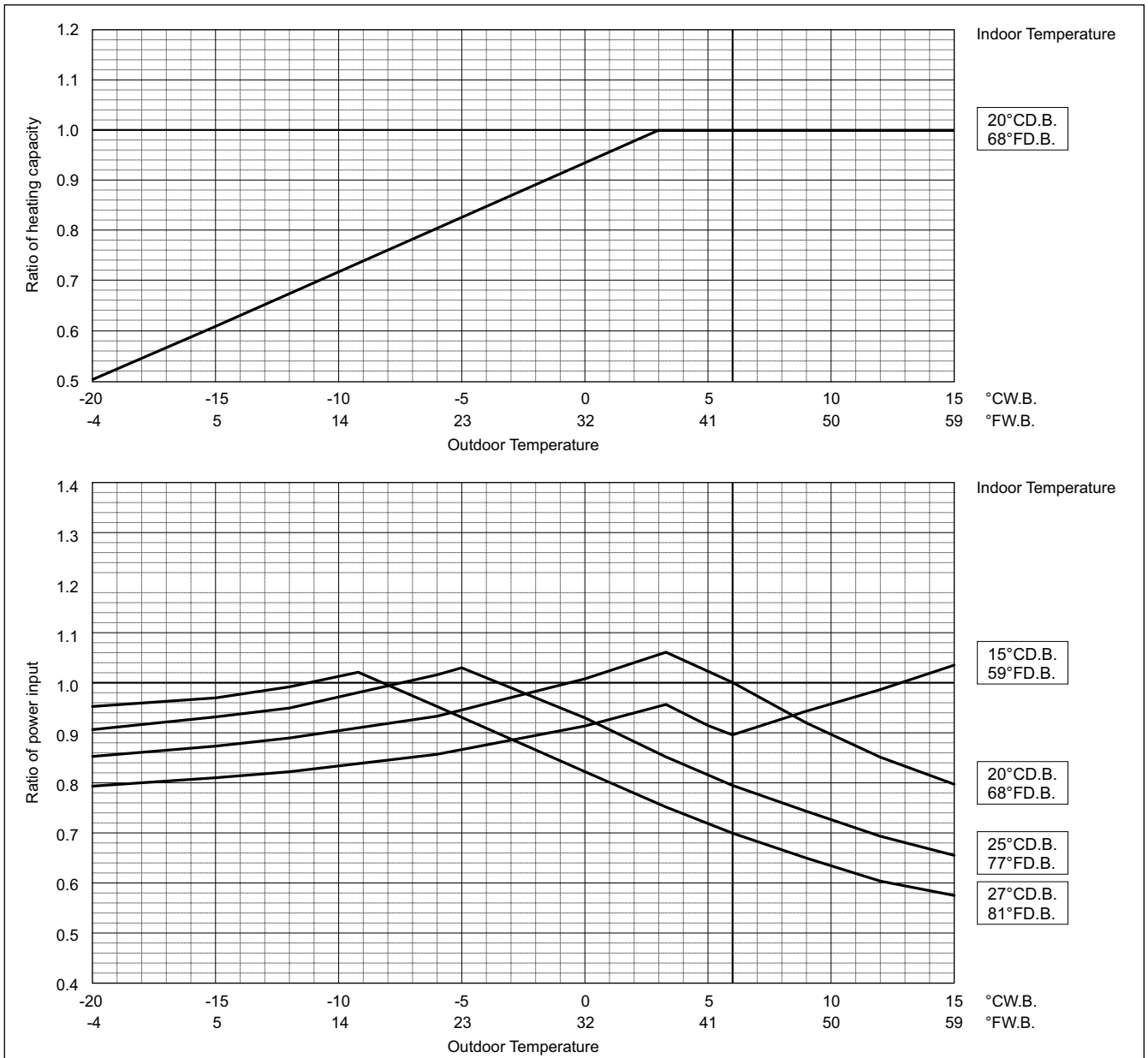

Outdoor unit power input is affected by the indoor and outdoor temperatures as shown in the graph above. Please consult the sales office for details.

8. CAPACITY TABLES

PURY-		P300YLM-A1	P350YLM-A1	P400YLM-A1
Nominal Cooling Capacity	kW	33.5	40.0	45.0
	BTU/h	114,300	136,500	153,500
Input	kW	9.10	11.76	13.71

PURY-		P400YSLM-A1
Nominal Cooling Capacity	kW	45.0
	BTU/h	153,500
Input	kW	10.97

Indoor unit temperature correction

To be used to correct indoor unit capacity only

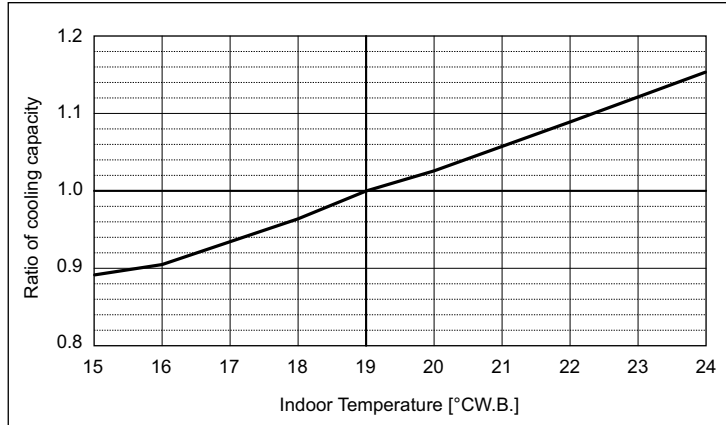

Outdoor unit temperature correction

To be used to correct outdoor unit only

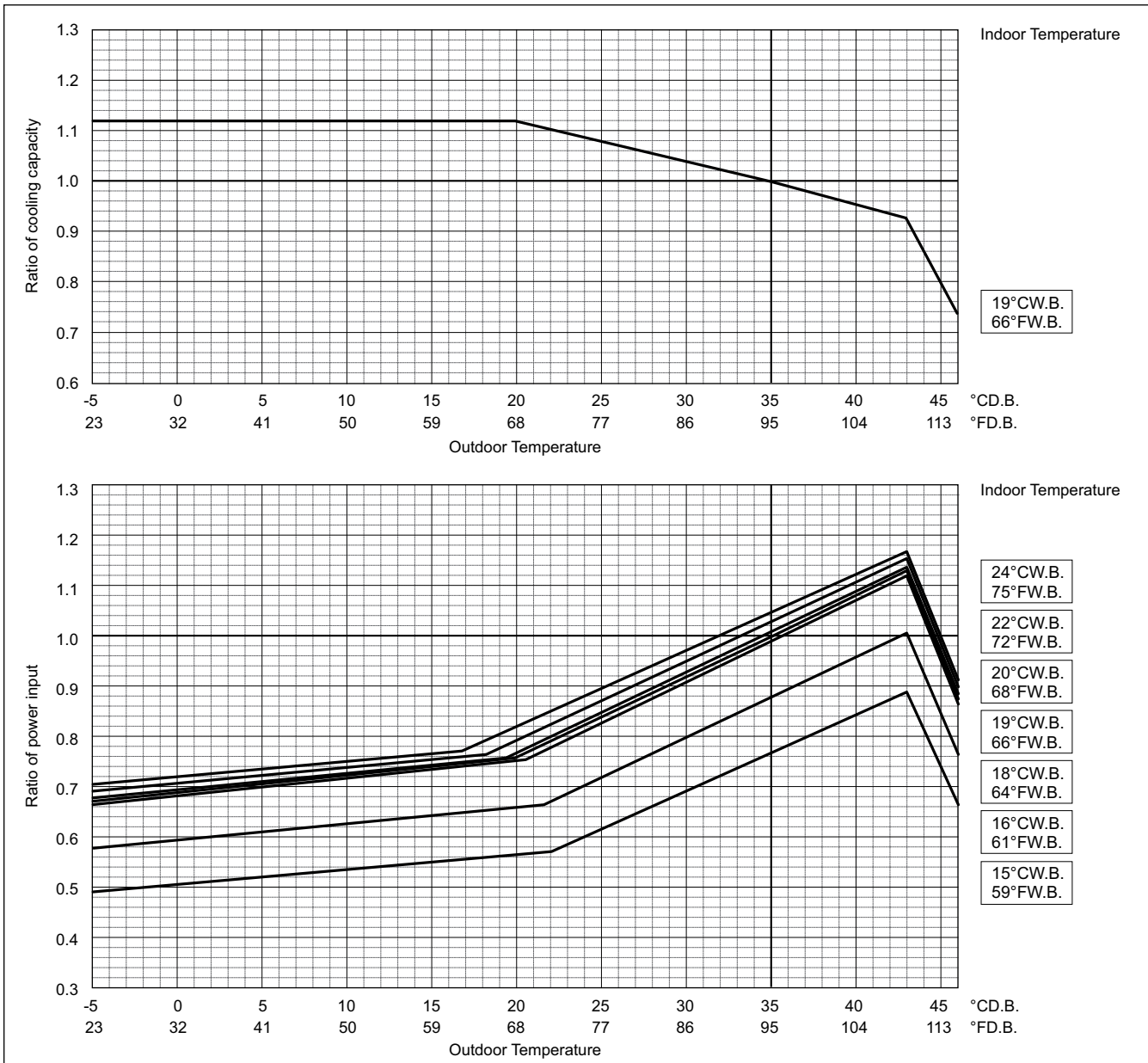

Outdoor unit power input is affected by the indoor and outdoor temperatures as shown in the graph above. Please consult the sales office for details.

PURY-	P300YLM-A1	P350YLM-A1	P400YLM-A1
Nominal Heating Capacity	kW 37.5	45.0	45.0
	BTU/h 128,000	153,500	153,500
Input	kW 9.37	11.59	11.42

PURY-	P400YSLM-A1
Nominal Heating Capacity	kW 50.0
	BTU/h 170,600
Input	kW 10.98

Indoor unit temperature correction

To be used to correct indoor unit capacity only

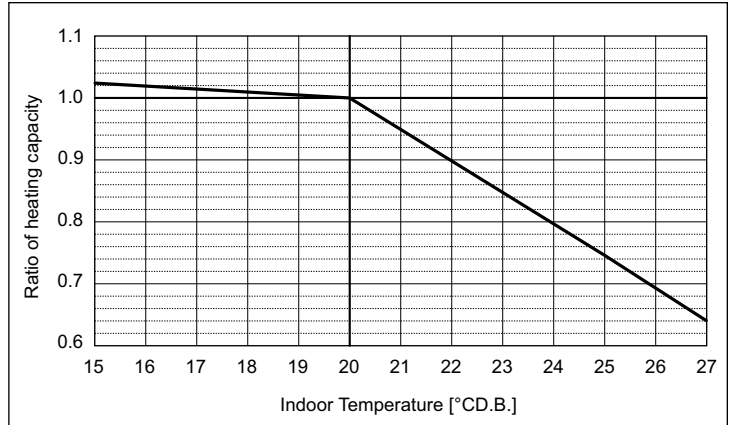

Outdoor unit temperature correction

To be used to correct outdoor unit only

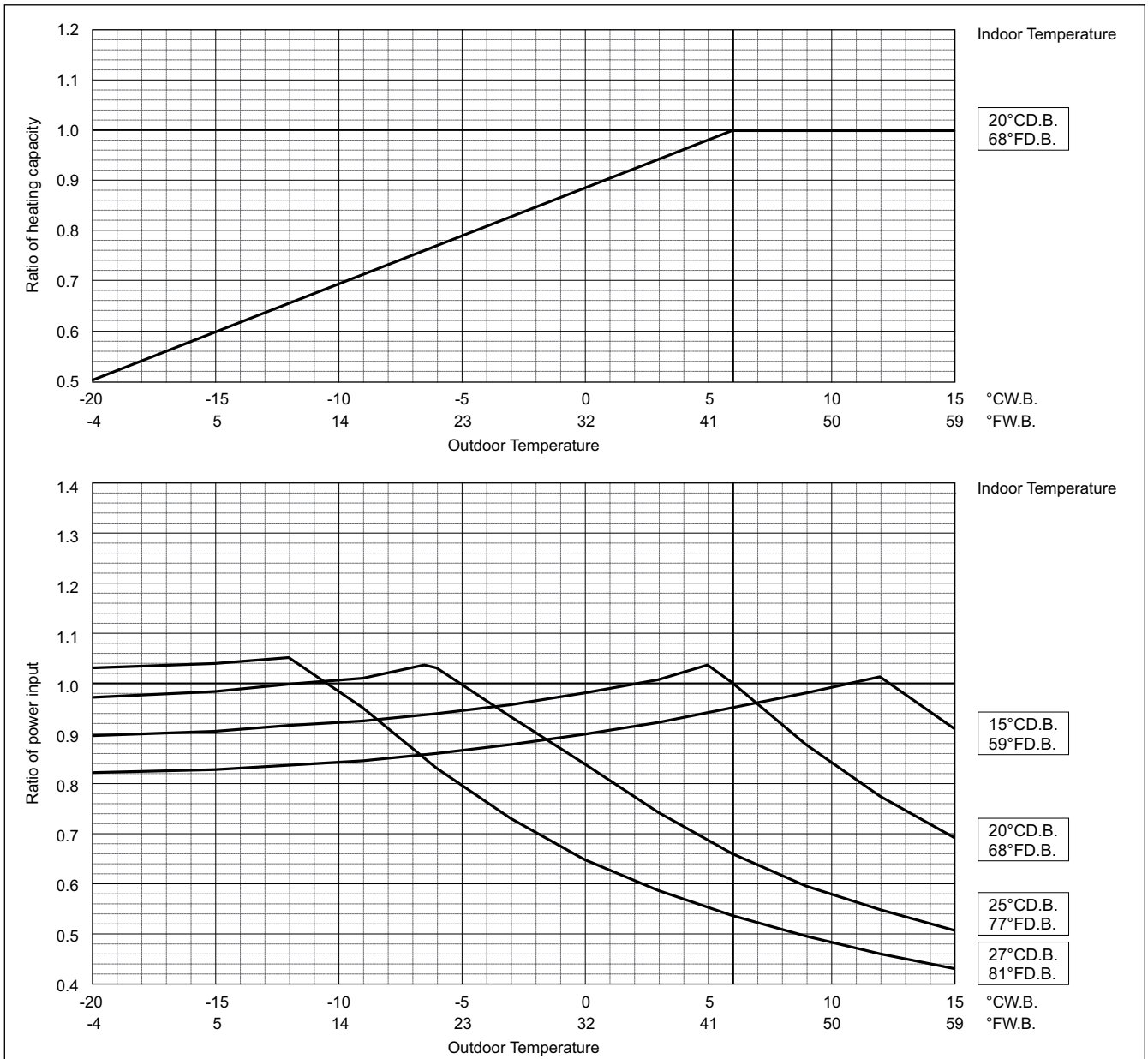

Outdoor unit power input is affected by the indoor and outdoor temperatures as shown in the graph above. Please consult the sales office for details.

PURY-		P450YLM-A1	P500YLM-A1	P450YSLM-A1
Nominal Cooling Capacity	kW	50.0	56.0	50.0
	BTU/h	170,600	191,100	170,600
Input	kW	14.32	17.77	12.50

PURY-		P500YSLM-A1	P550YSLM-A1	P600YSLM-A1
Nominal Cooling Capacity	kW	56.0	63.0	69.0
	BTU/h	191,100	215,000	235,400
Input	kW	14.39	16.89	19.32

PURY-		P650YSLM-A1
Nominal Cooling Capacity	kW	73.0
	BTU/h	249,100
Input	kW	21.28

Indoor unit temperature correction
To be used to correct indoor unit capacity only

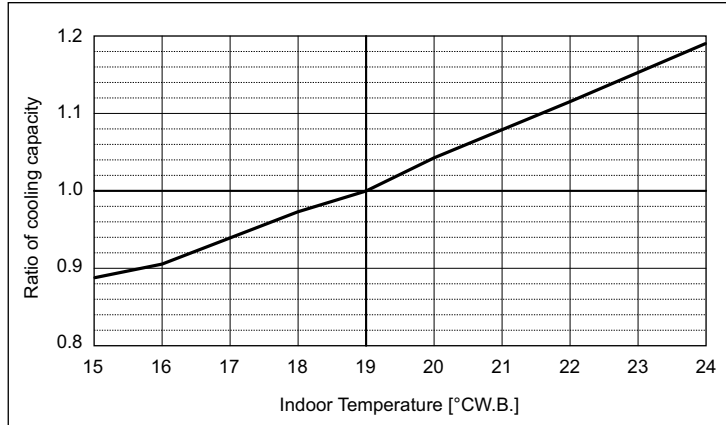

Outdoor unit temperature correction
To be used to correct outdoor unit only

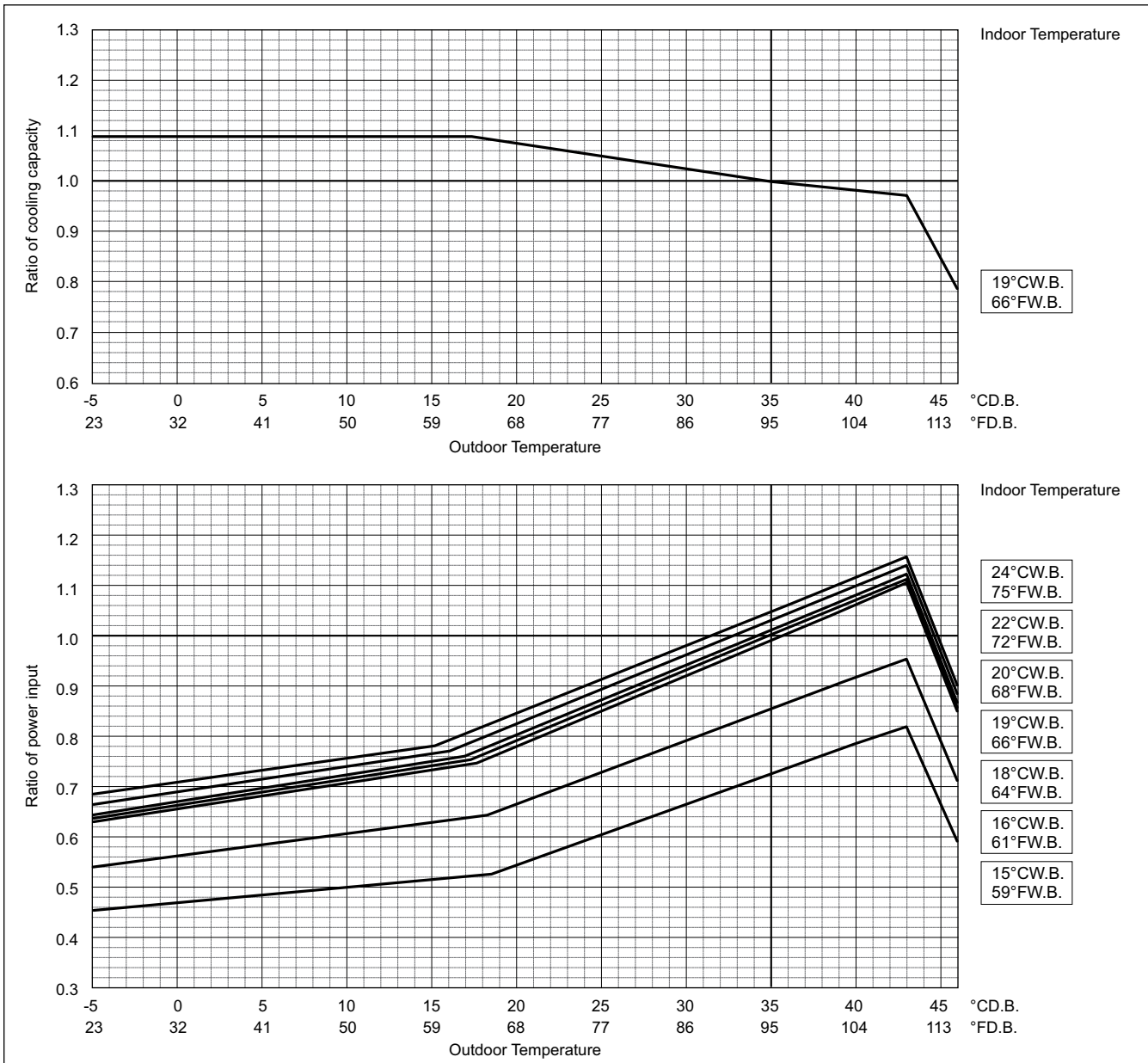

Outdoor unit power input is affected by the indoor and outdoor temperatures as shown in the graph above. Please consult the sales office for details.

PURY-	P450YLM-A1	P500YLM-A1	P450YSLM-A1
Nominal Heating Capacity	kW 56.0	58.0	56.0
	BTU/h 191,100	197,900	191,100
Input	kW 14.93	16.06	12.64

PURY-	P500YSLM-A1	P550YSLM-A1	P600YSLM-A1
Nominal Heating Capacity	kW 63.0	69.0	76.5
	BTU/h 215,000	235,400	261,000
Input	kW 14.65	16.62	19.12

PURY-	P650YSLM-A1
Nominal Heating Capacity	kW 81.5
	BTU/h 278,100
Input	kW 20.68

Indoor unit temperature correction
To be used to correct indoor unit capacity only

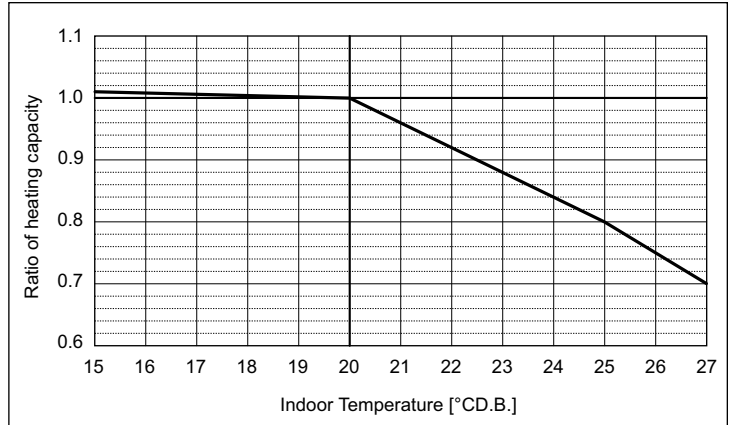

Outdoor unit temperature correction
To be used to correct outdoor unit only

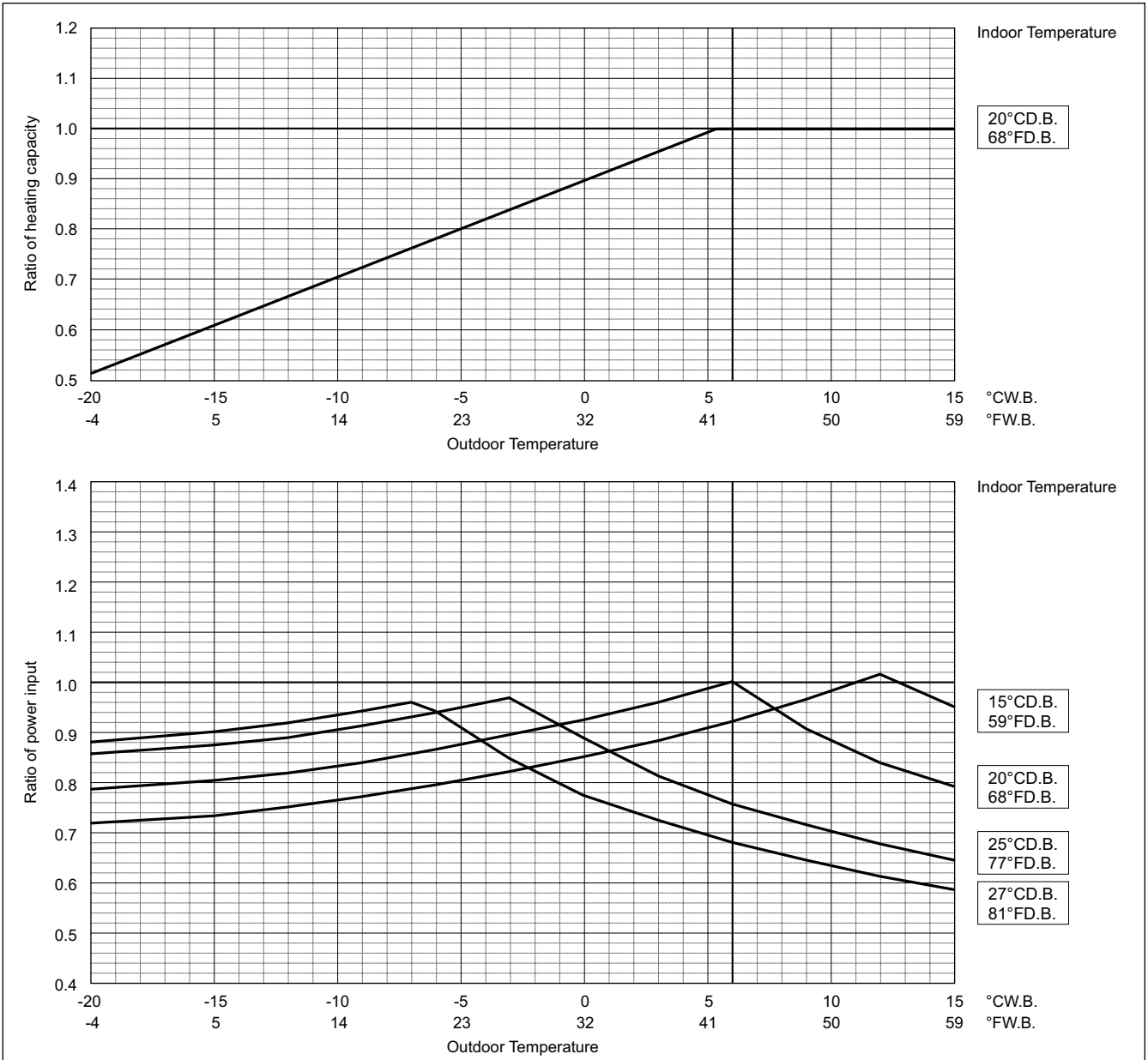

Outdoor unit power input is affected by the indoor and outdoor temperatures as shown in the graph above. Please consult the sales office for details.

PURY-	P700YSLM-A1	P750YSLM-A1	P800YSLM-A1
Nominal Cooling Capacity	80.0	85.0	90.0
	BTU/h	290,000	307,100
Input	24.24	26.23	28.30
	kW		

Indoor unit temperature correction

To be used to correct indoor unit capacity only

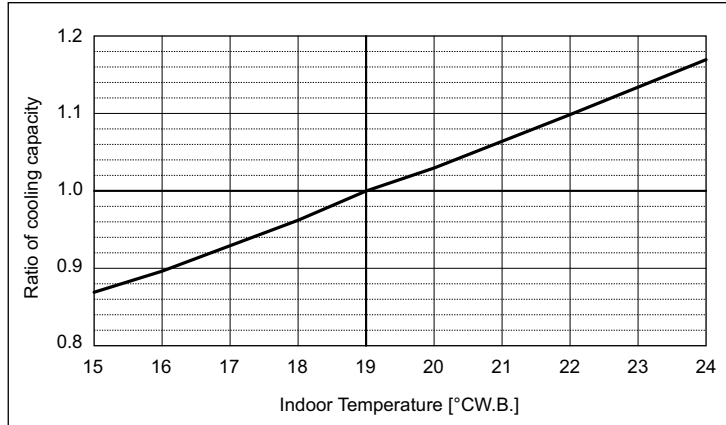

Outdoor unit temperature correction

To be used to correct outdoor unit only

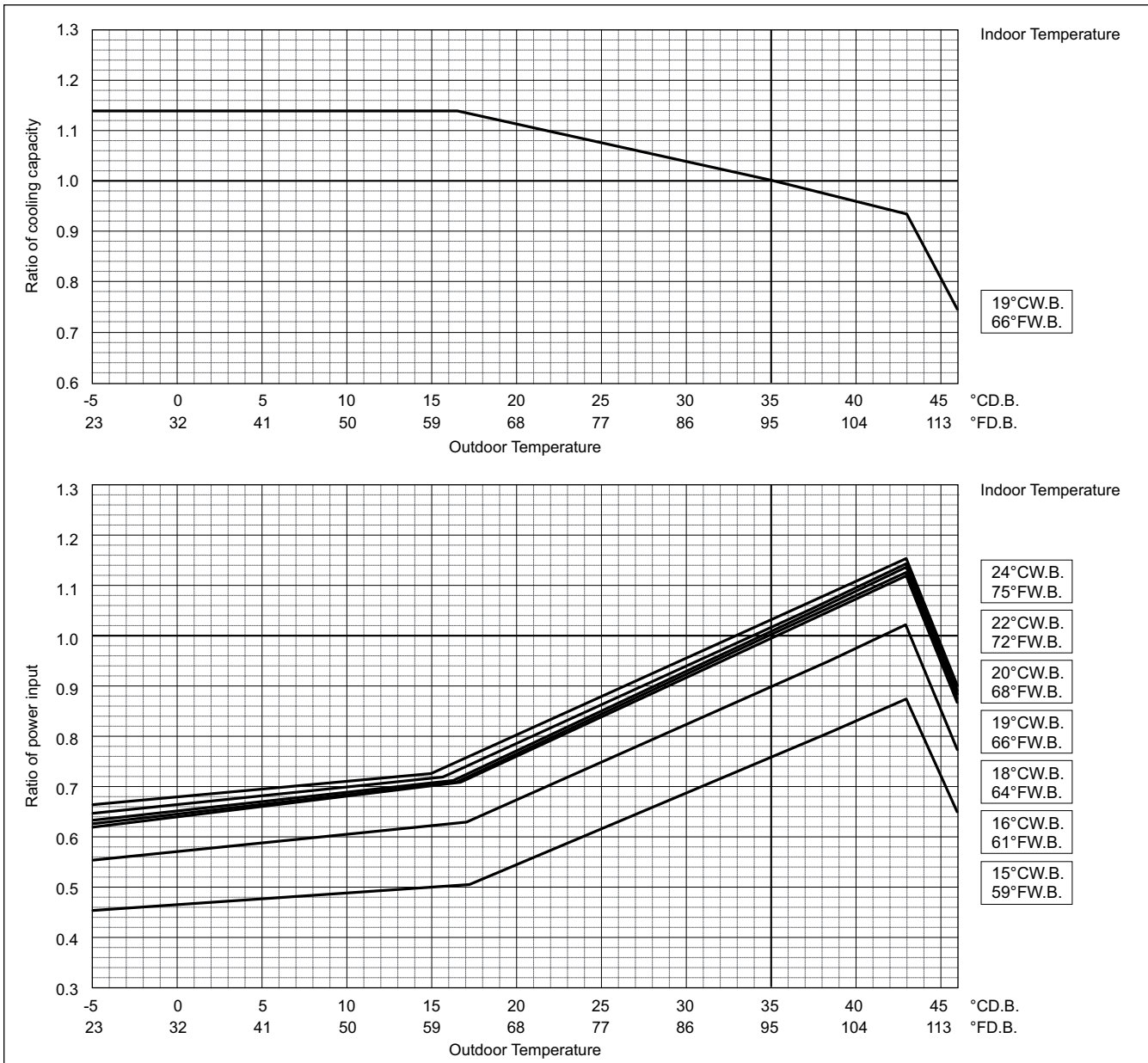

Outdoor unit power input is affected by the indoor and outdoor temperatures as shown in the graph above. Please consult the sales office for details.

	PURY-	P700YSLM-A1	P750YSLM-A1	P800YSLM-A1
Nominal Heating Capacity	kW	88.0	90.0	90.0
	BTU/h	300,300	307,100	307,100
Input	kW	22.68	23.01	22.84

Indoor unit temperature correction

To be used to correct indoor unit capacity only

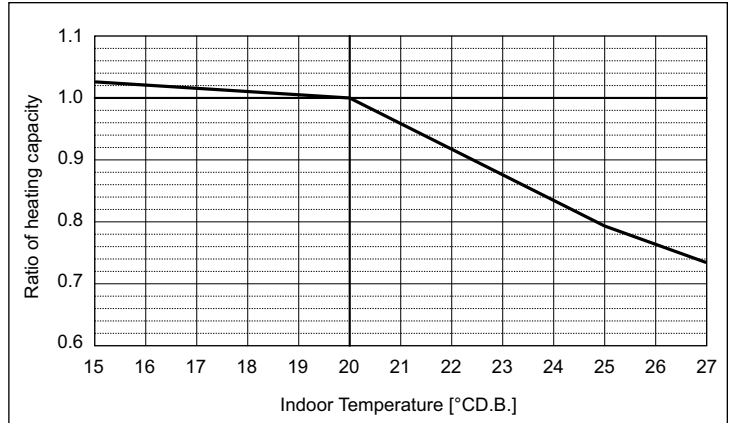

Outdoor unit temperature correction

To be used to correct outdoor unit only

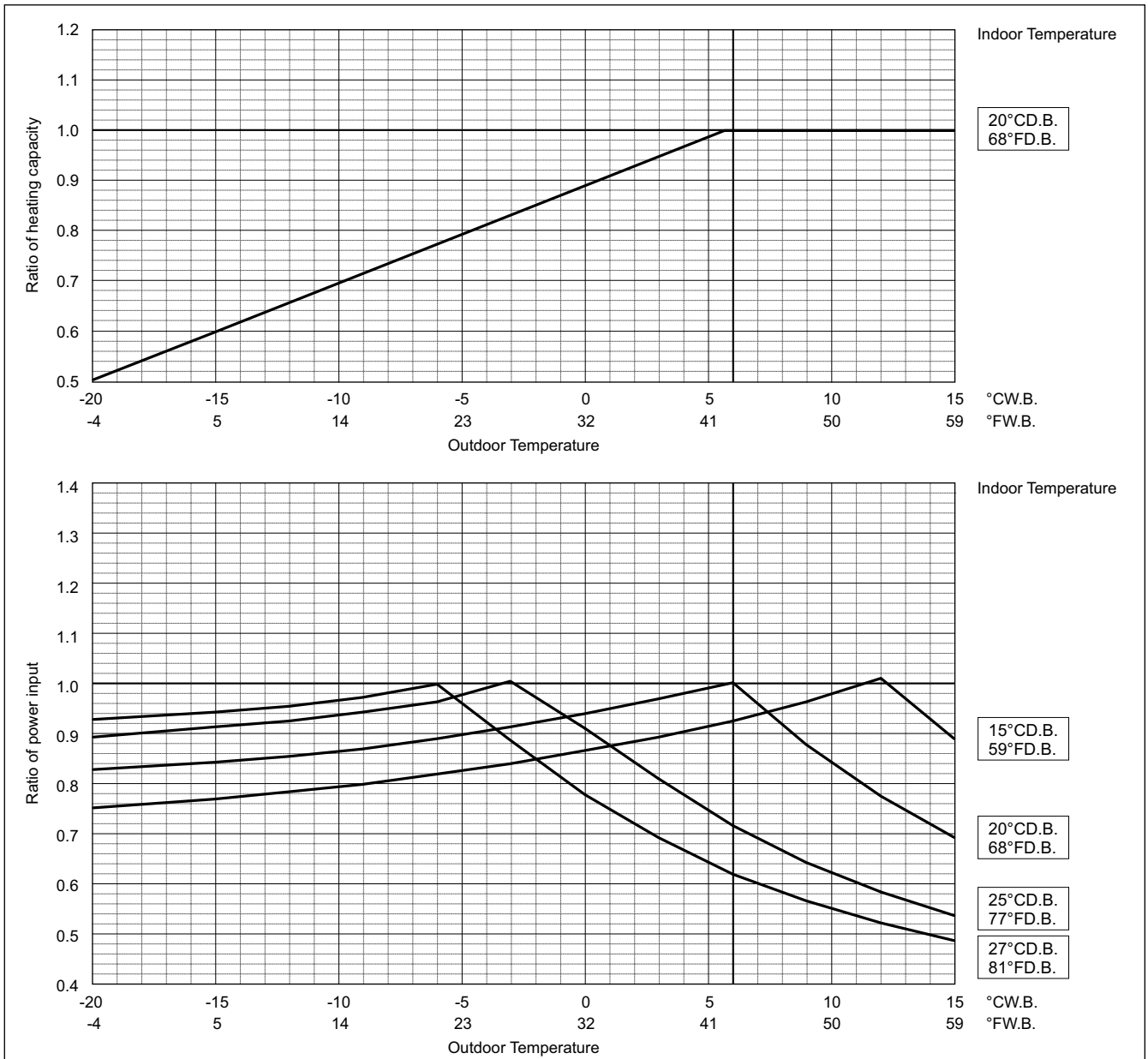

Outdoor unit power input is affected by the indoor and outdoor temperatures as shown in the graph above. Please consult the sales office for details.

8. CAPACITY TABLES

PURY-	P850YSLM-A1	P900YSLM-A1
Nominal Cooling Capacity	96.0	101.0
BTU/h	327,600	344,600
Input	29.26	29.79
kW		

Indoor unit temperature correction

To be used to correct indoor unit capacity only

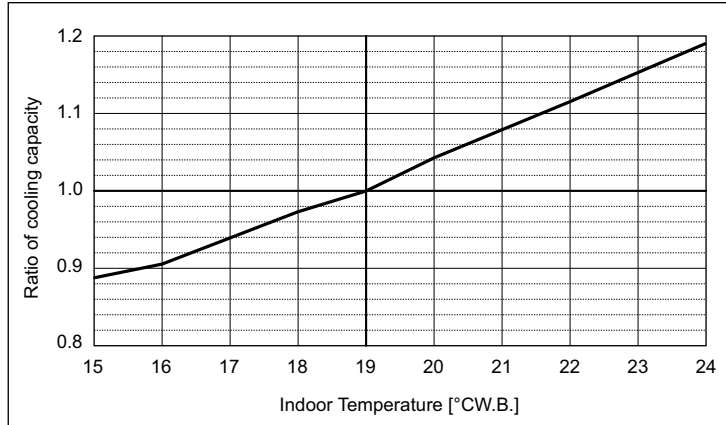

Outdoor unit temperature correction

To be used to correct outdoor unit only

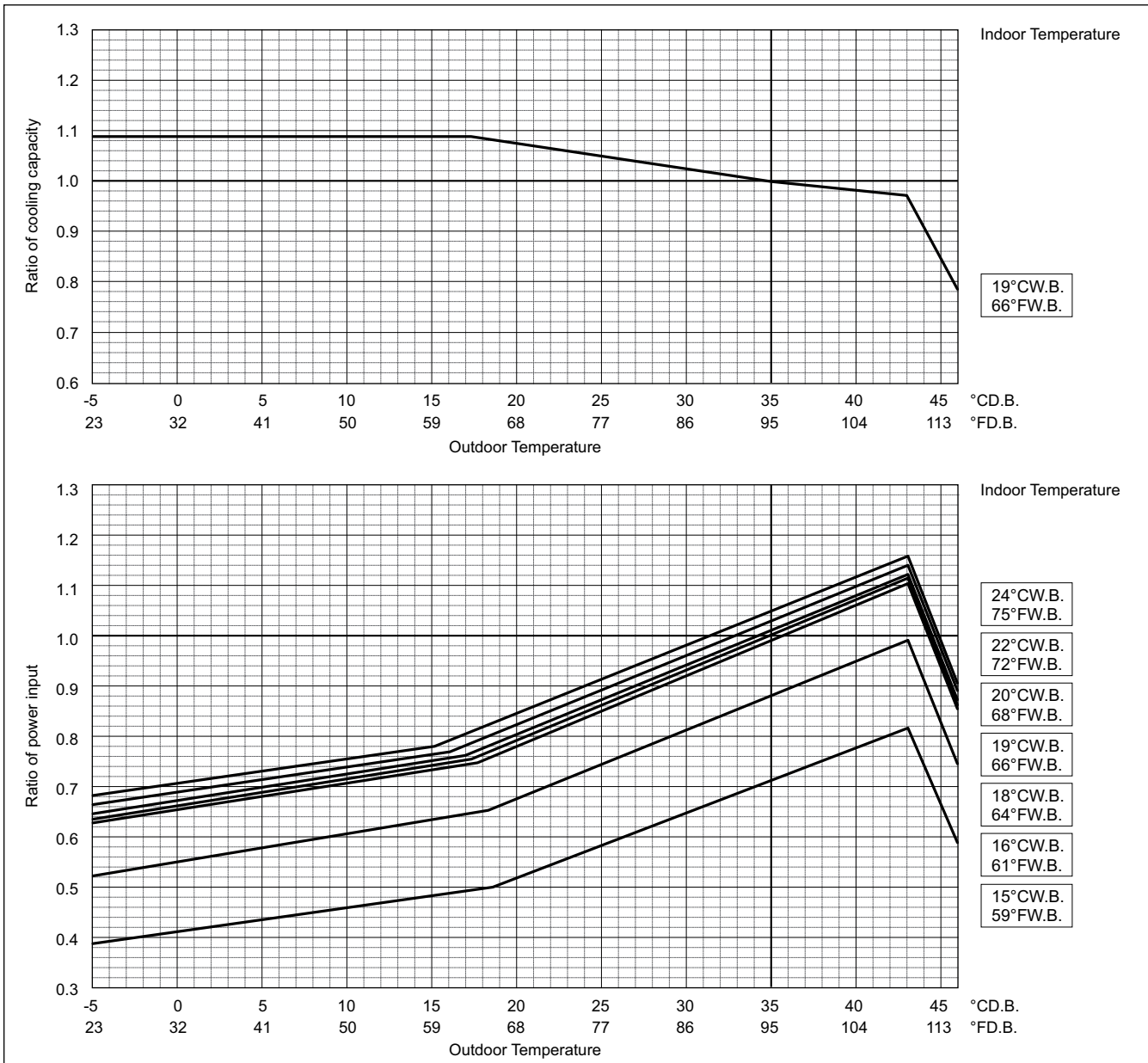

Outdoor unit power input is affected by the indoor and outdoor temperatures as shown in the graph above. Please consult the sales office for details.

PURY-	P850YSLM-A1	P900YSLM-A1
Nominal Heating Capacity	kW 101.0	113.0
	BTU/h 344,600	385,600
Input	kW 26.23	30.13

Indoor unit temperature correction

To be used to correct indoor unit capacity only

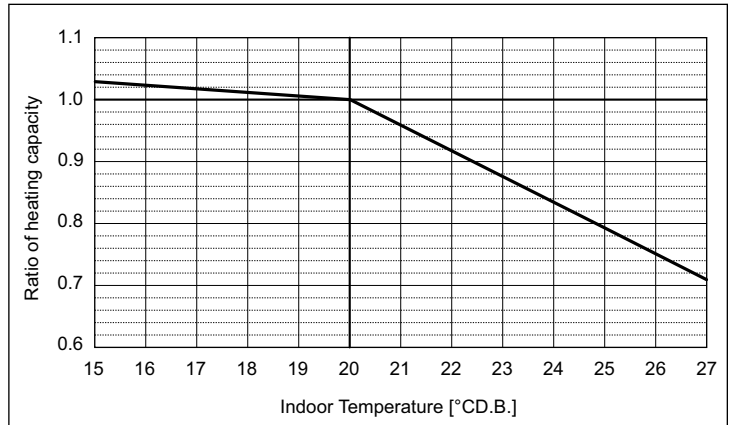

Outdoor unit temperature correction

To be used to correct outdoor unit only

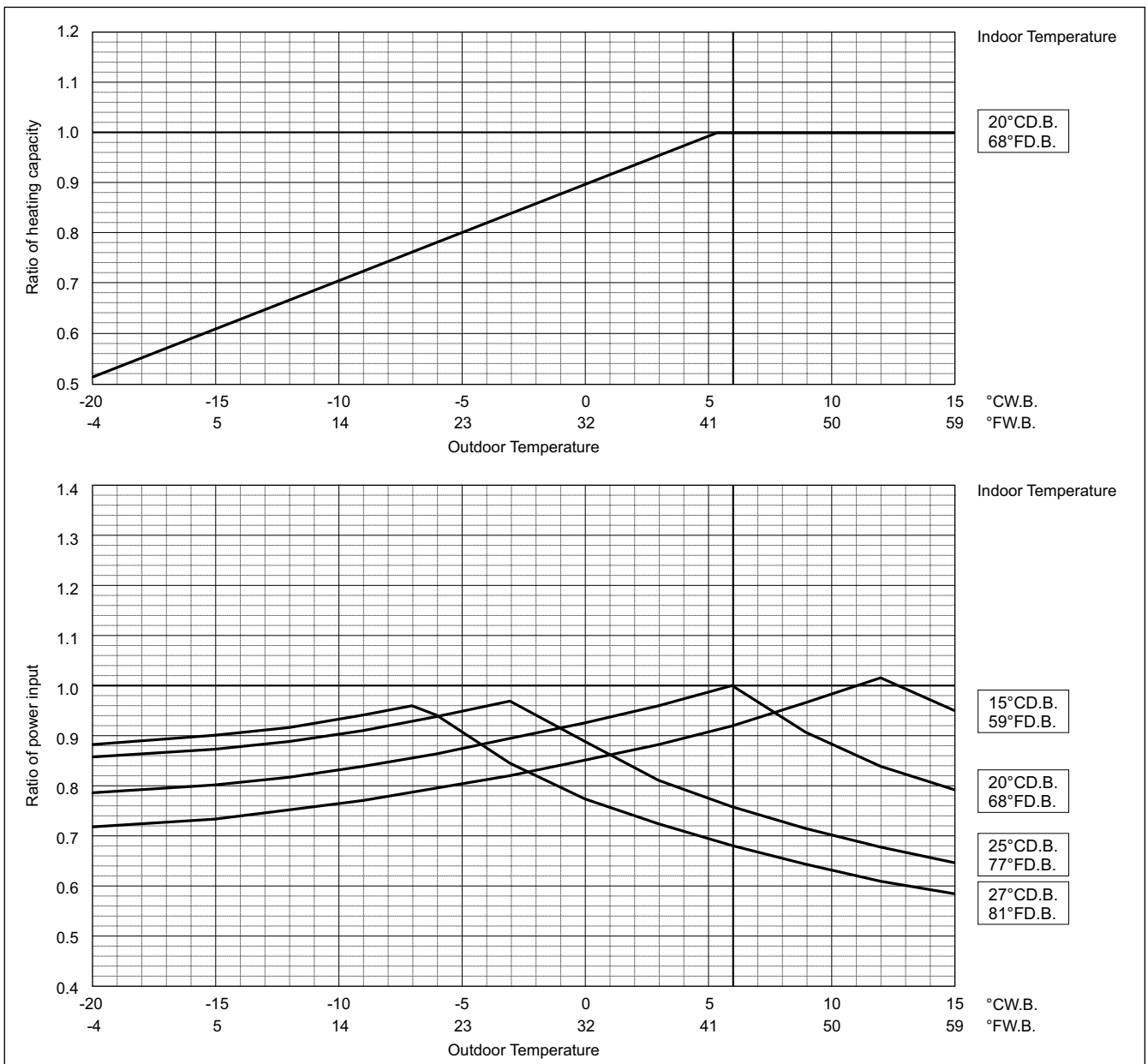

Outdoor unit power input is affected by the indoor and outdoor temperatures as shown in the graph above. Please consult the sales office for details.

R2

8-3. Correction by total indoor

PURY-P200YLM-A1		
Nominal Cooling Capacity	kW	22.4
	BTU/h	76,400
Input	kW	5.29

PURY-P200YLM-A1		
Nominal Heating Capacity	kW	25.0
	BTU/h	85,300
Input	kW	5.49

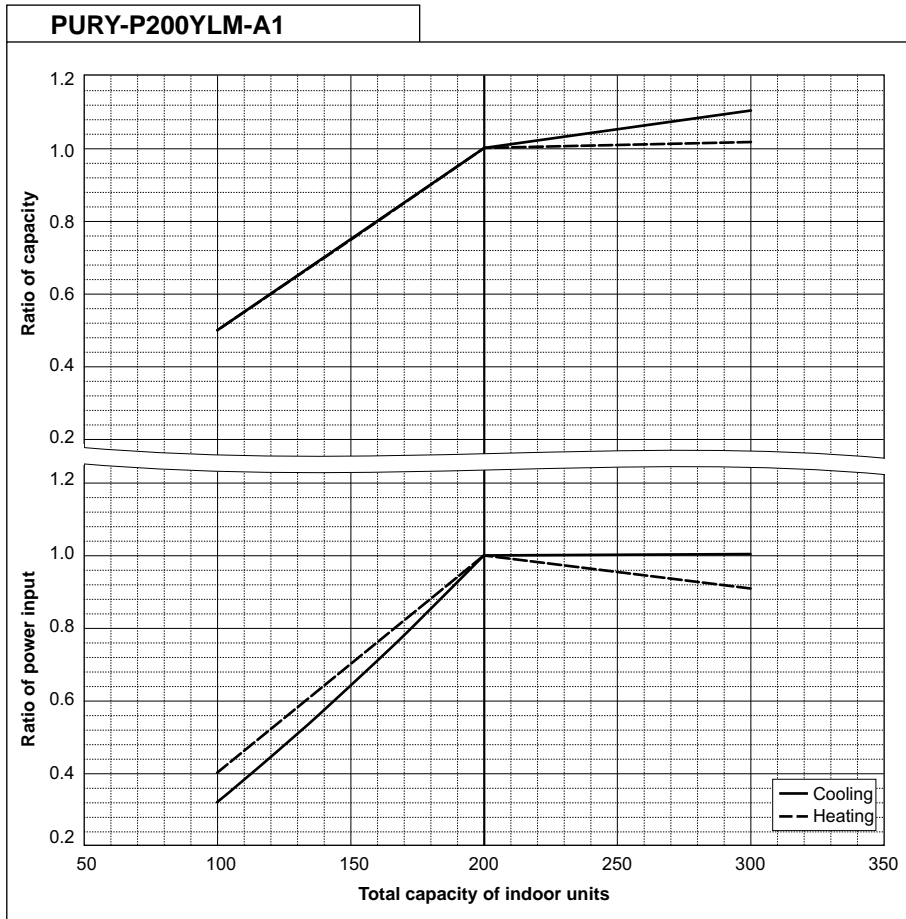

PURY-P250YLM-A1		
Nominal Cooling Capacity	kW	28.0
	BTU/h	95,500
Input	kW	6.98

PURY-P250YLM-A1		
Nominal Heating Capacity	kW	31.5
	BTU/h	107,500
Input	kW	7.32

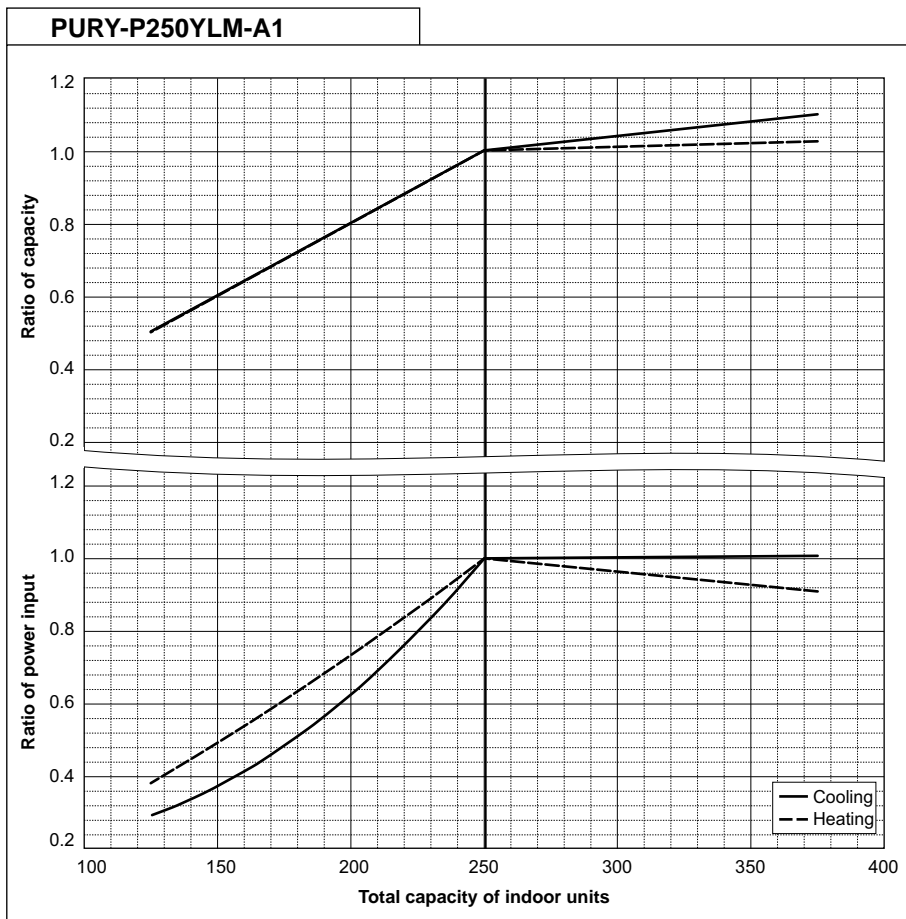

PURY-P300YLM-A1		
Nominal Cooling Capacity	kW	33.5
	BTU/h	114,300
Input	kW	9.10

PURY-P300YLM-A1		
Nominal Heating Capacity	kW	37.5
	BTU/h	128,000
Input	kW	9.37

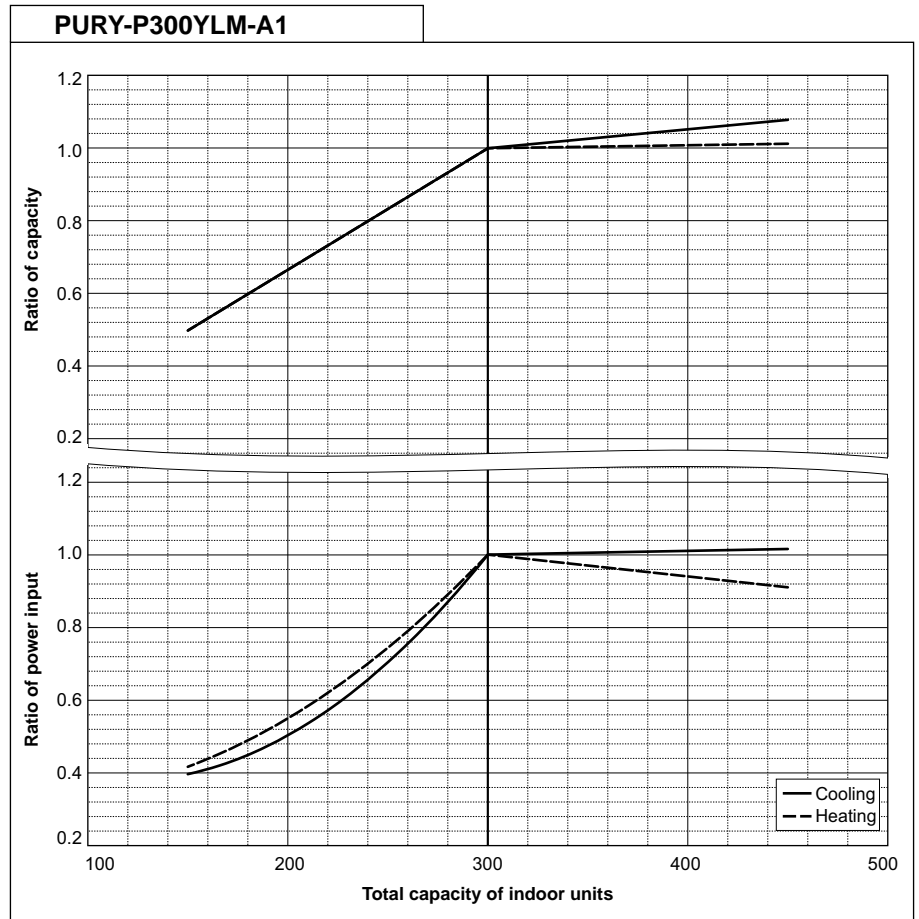

PURY-P350YLM-A1		
Nominal Cooling Capacity	kW	40.0
	BTU/h	136,500
Input	kW	11.76

PURY-P350YLM-A1		
Nominal Heating Capacity	kW	45.0
	BTU/h	153,500
Input	kW	11.59

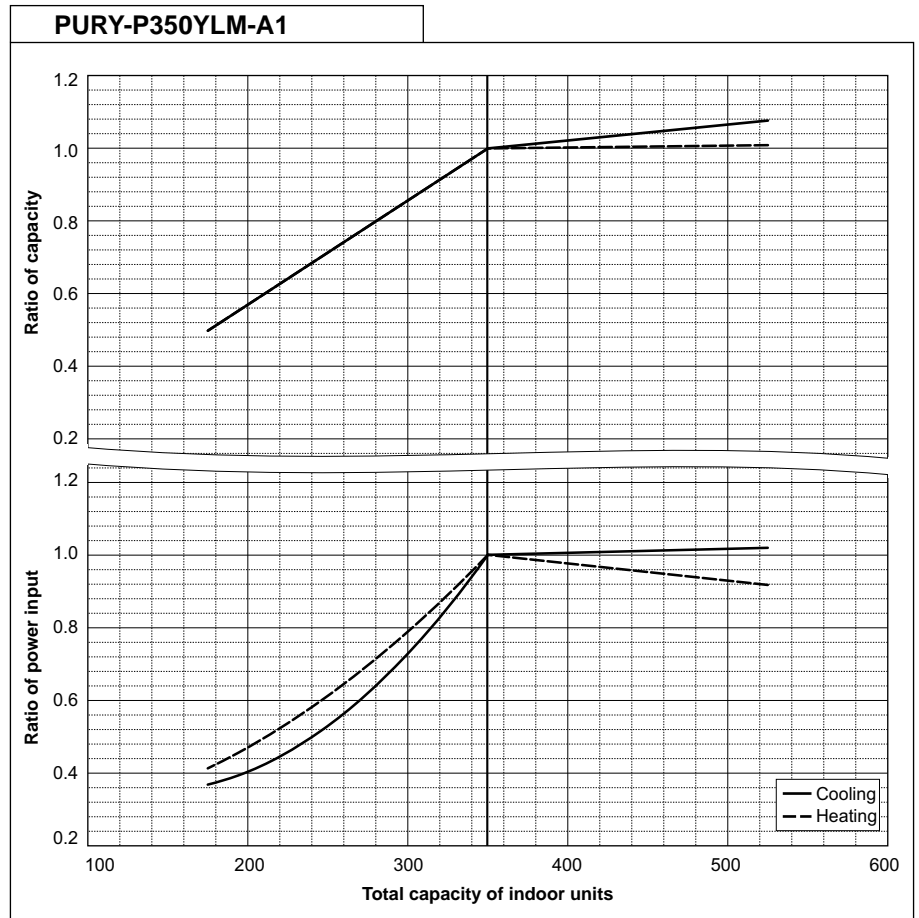

R2

R2

PURY-P400YLM-A1		
Nominal Cooling Capacity	kW	45.0
	BTU/h	153,500
Input	kW	13.71

PURY-P400YLM-A1		
Nominal Heating Capacity	kW	45.0
	BTU/h	153,500
Input	kW	11.42

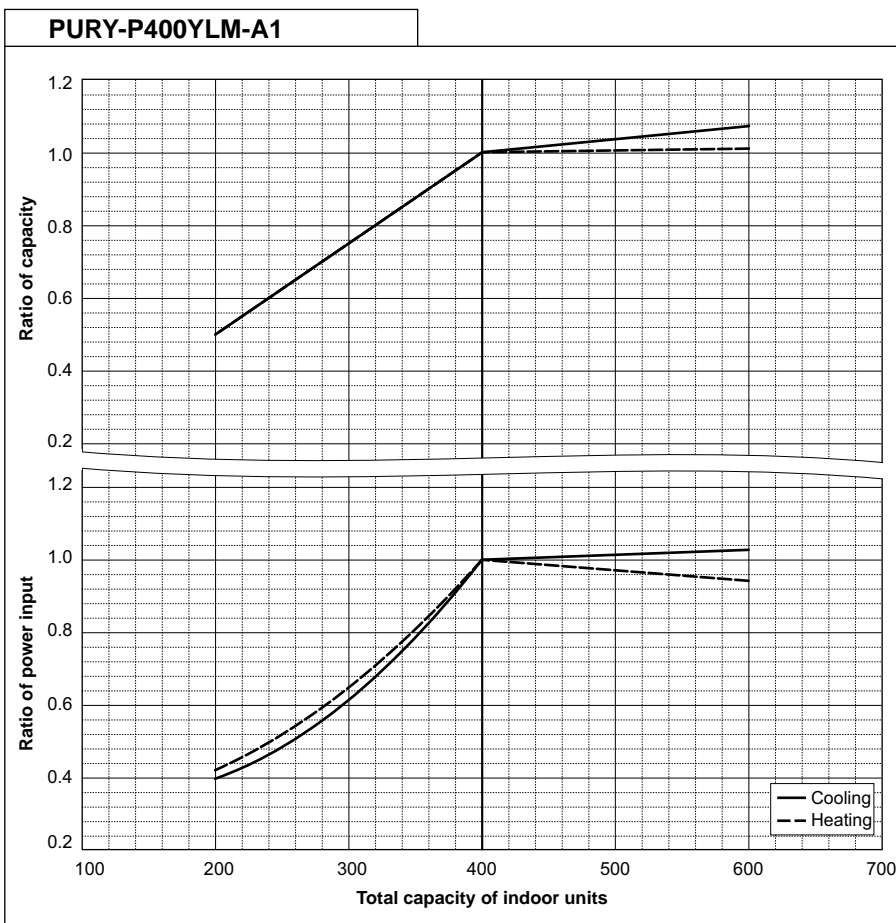

PURY-P450YLM-A1		
Nominal Cooling Capacity	kW	50.0
	BTU/h	170,600
Input	kW	14.32

PURY-P450YLM-A1		
Nominal Heating Capacity	kW	56.0
	BTU/h	191,100
Input	kW	14.93

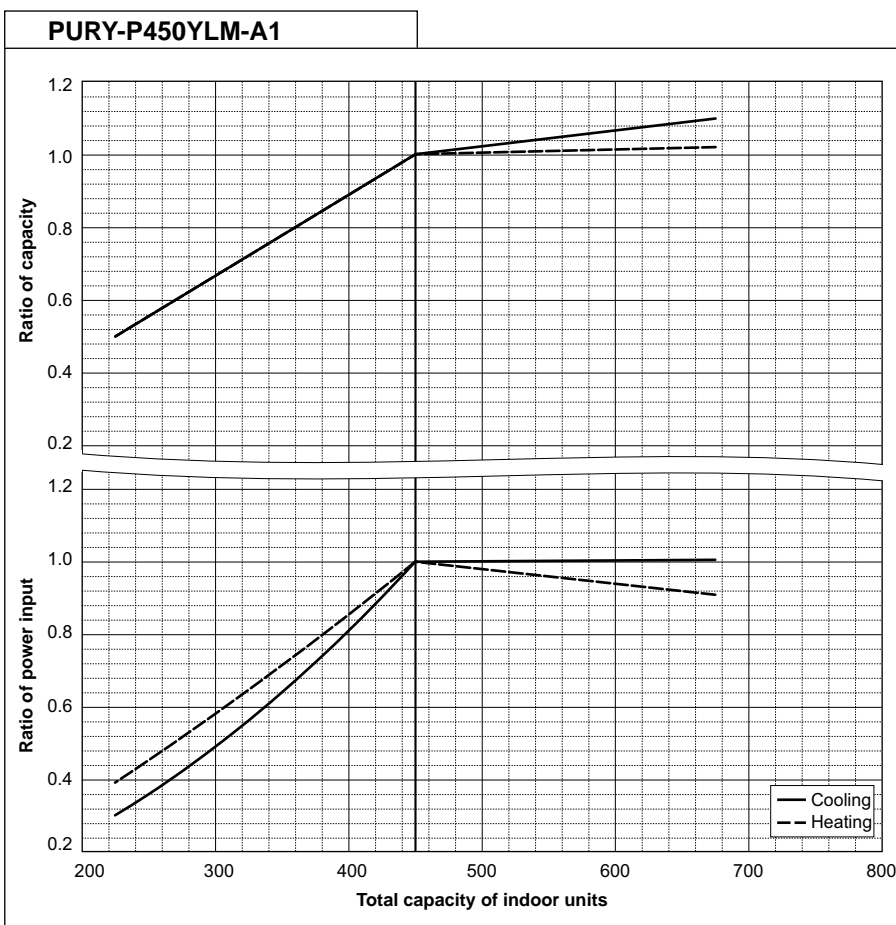

PURY-P500YLM-A1		
Nominal Cooling Capacity	kW	56.0
	BTU/h	191,100
Input	kW	17.77

PURY-P500YLM-A1		
Nominal Heating Capacity	kW	58.0
	BTU/h	197,900
Input	kW	16.06

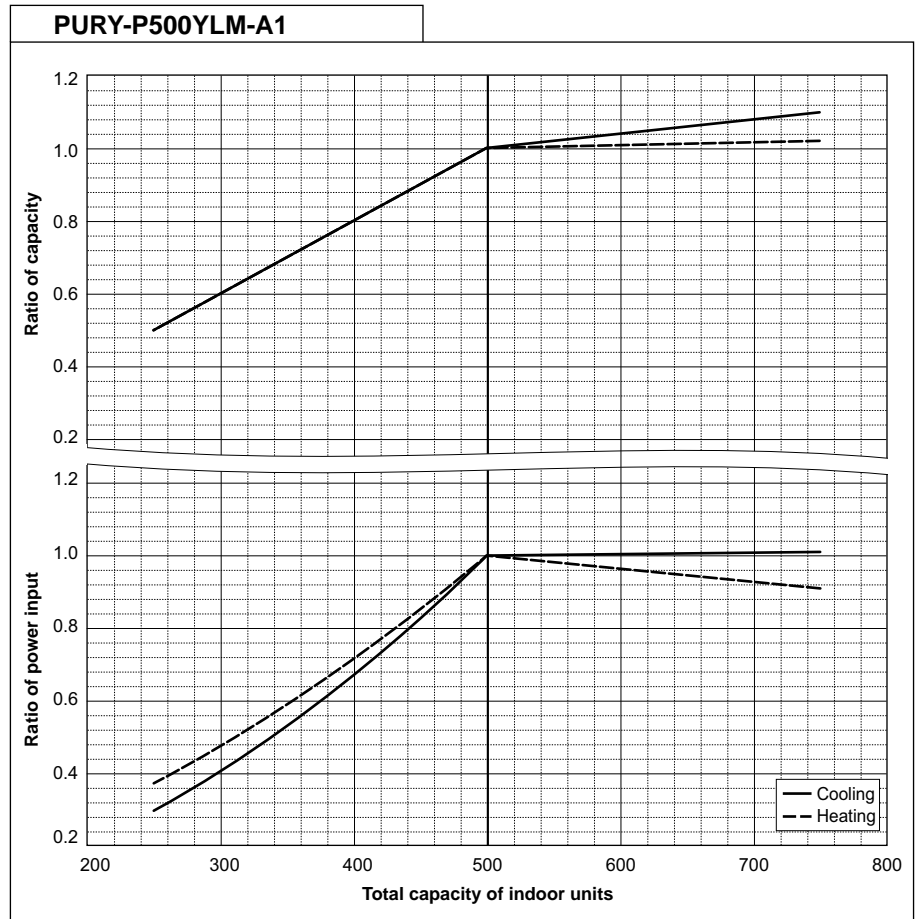

PURY-P400YSLM-A1		
Nominal Cooling Capacity	kW	45.0
	BTU/h	153,500
Input	kW	10.97

PURY-P400YSLM-A1		
Nominal Heating Capacity	kW	50.0
	BTU/h	170,600
Input	kW	10.98

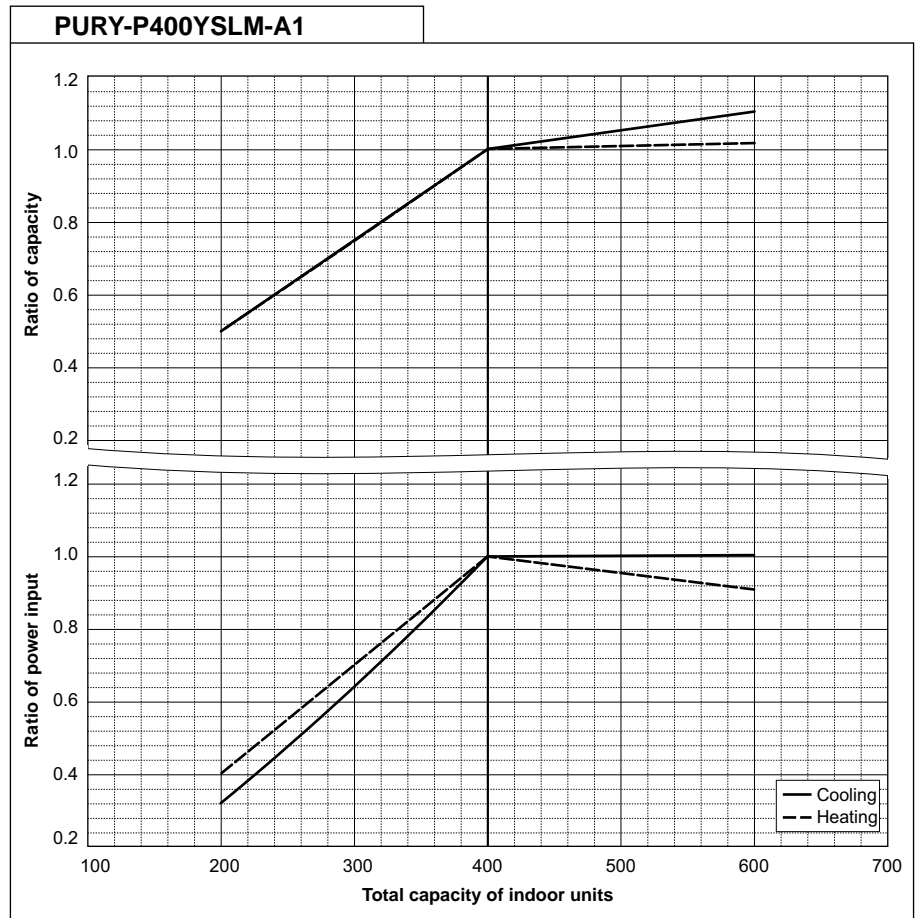

R2

PURY-P450YSLM-A1		
Nominal Cooling Capacity	kW	50.0
	BTU/h	170,600
Input	kW	12.50

PURY-P450YSLM-A1		
Nominal Heating Capacity	kW	56.0
	BTU/h	191,100
Input	kW	12.64

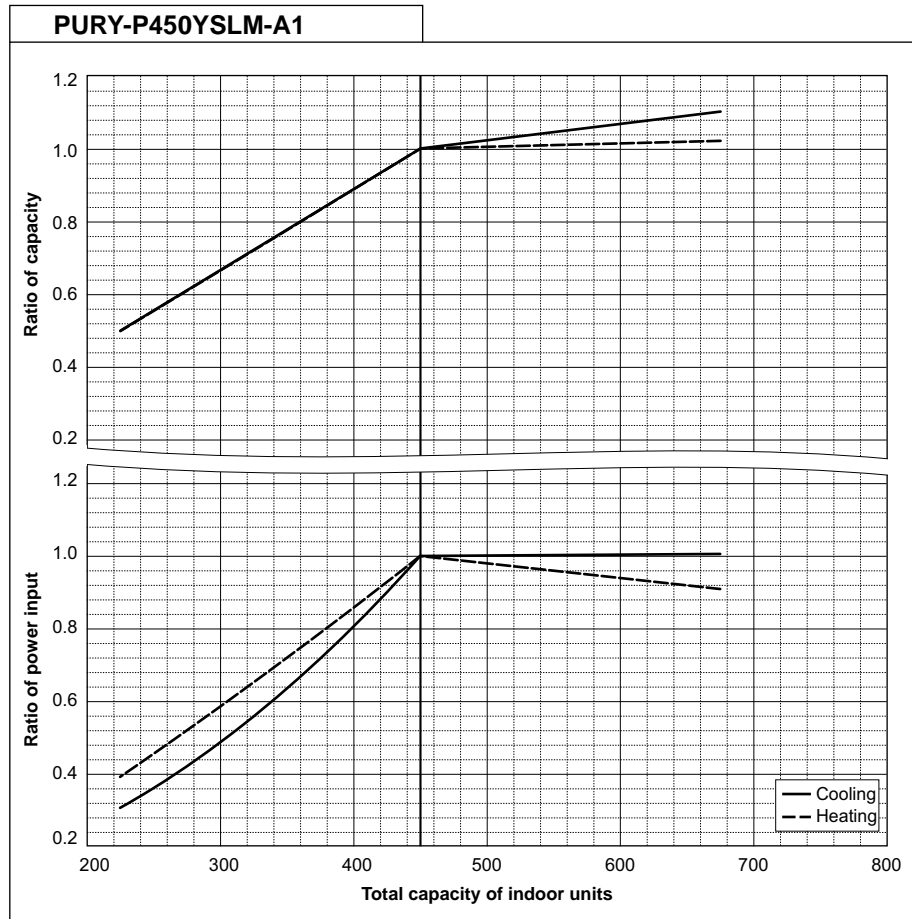

PURY-P500YSLM-A1		
Nominal Cooling Capacity	kW	56.0
	BTU/h	191,100
Input	kW	14.39

PURY-P500YSLM-A1		
Nominal Heating Capacity	kW	63.0
	BTU/h	215,000
Input	kW	14.65

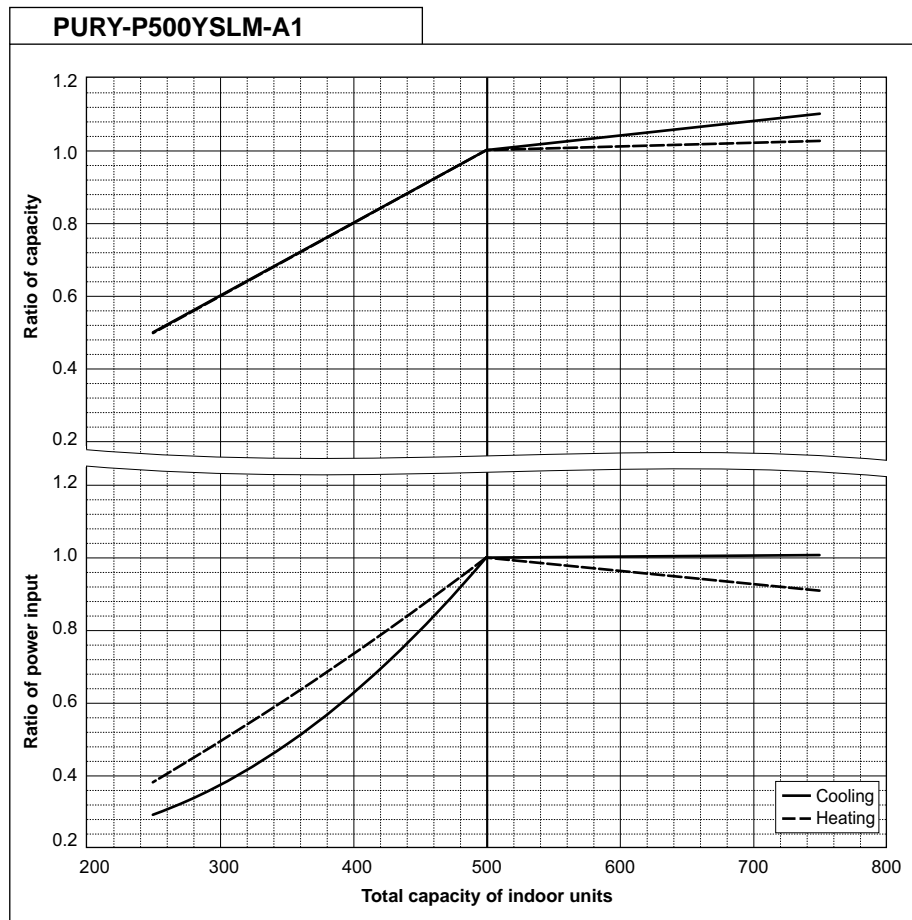

PURY-P550YSLM-A1		
Nominal Cooling Capacity	kW	63.0
	BTU/h	215,000
Input	kW	16.89

PURY-P550YSLM-A1		
Nominal Heating Capacity	kW	69.0
	BTU/h	235,400
Input	kW	16.62

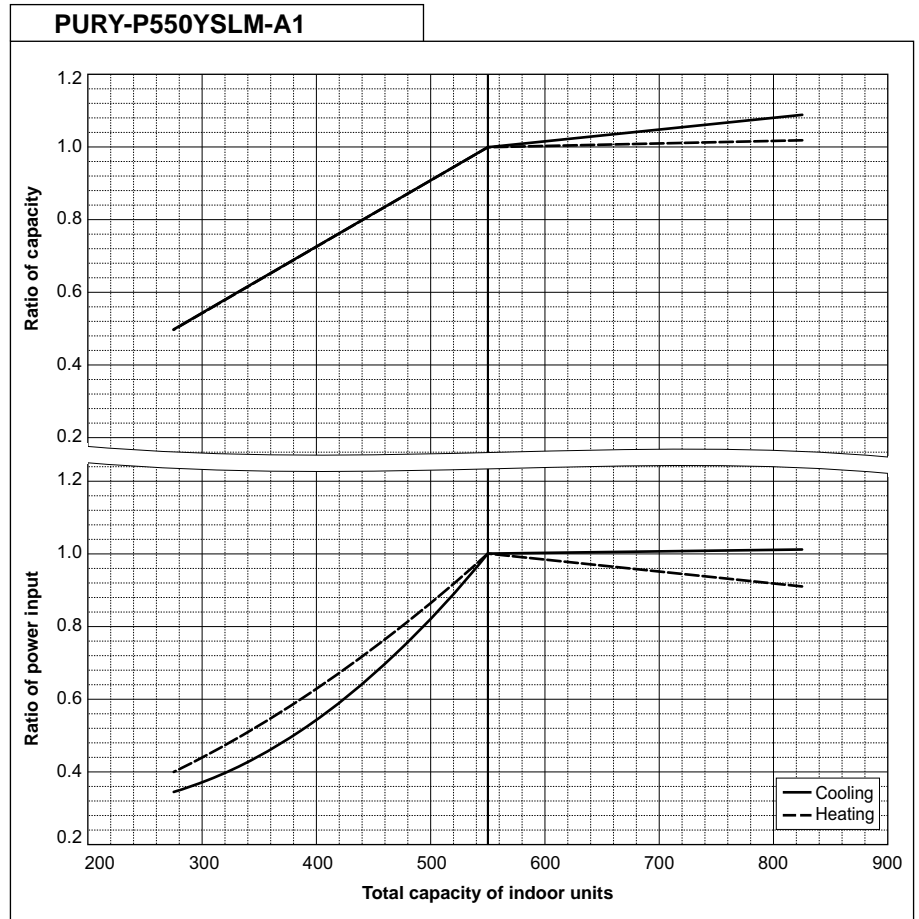

PURY-P600YSLM-A1		
Nominal Cooling Capacity	kW	69.0
	BTU/h	235,400
Input	kW	19.32

PURY-P600YSLM-A1		
Nominal Heating Capacity	kW	76.5
	BTU/h	261,000
Input	kW	19.12

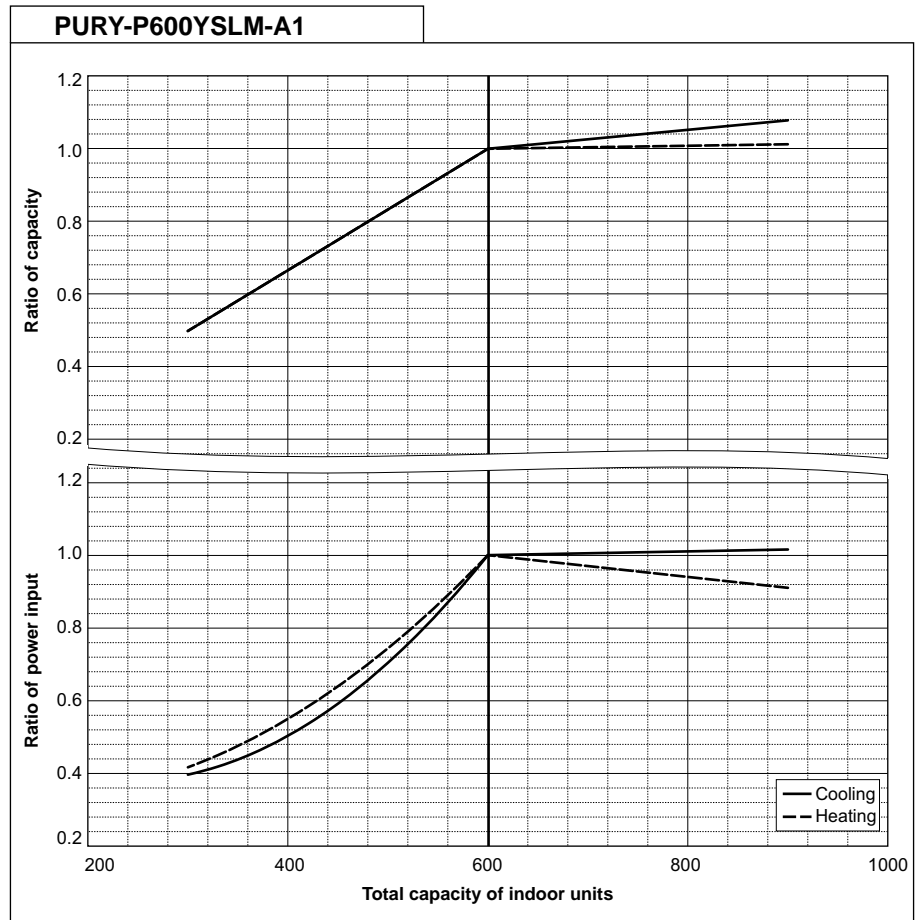

R2

8. CAPACITY TABLES

YKB/YLM

R2

PURY-P650YSLM-A1		
Nominal Cooling Capacity	kW	73.0
	BTU/h	249,100
Input	kW	21.28

PURY-P650YSLM-A1		
Nominal Heating Capacity	kW	81.5
	BTU/h	278,100
Input	kW	20.68

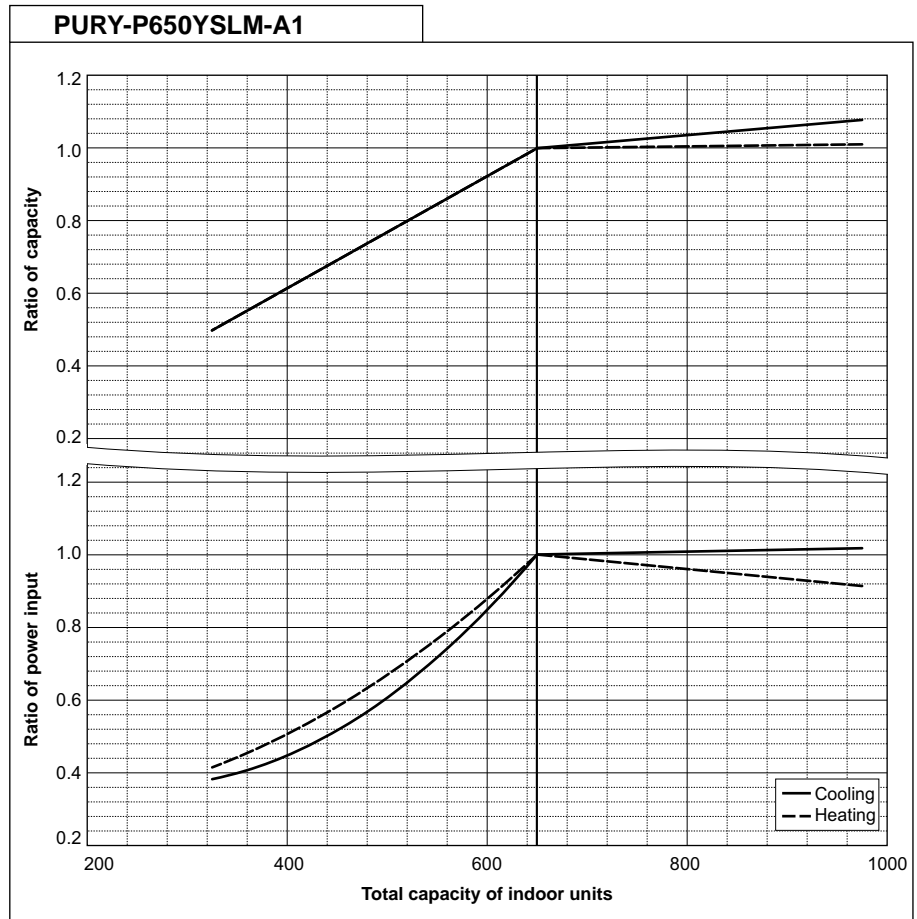

PURY-P700YSLM-A1		
Nominal Cooling Capacity	kW	80.0
	BTU/h	273,000
Input	kW	24.24

PURY-P700YSLM-A1		
Nominal Heating Capacity	kW	88.0
	BTU/h	300,300
Input	kW	22.68

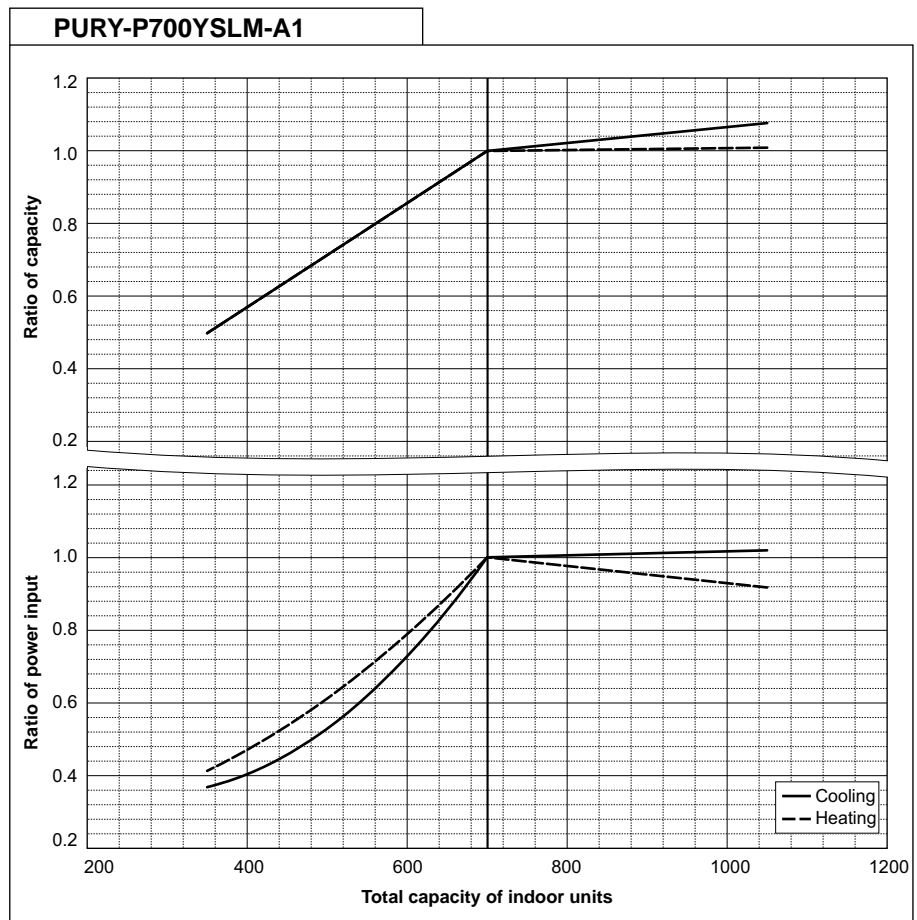

PURY-P750YSLM-A1		
Nominal Cooling Capacity	kW	85.0
	BTU/h	290,000
Input	kW	26.23

PURY-P750YSLM-A1		
Nominal Heating Capacity	kW	90.0
	BTU/h	307,100
Input	kW	23.01

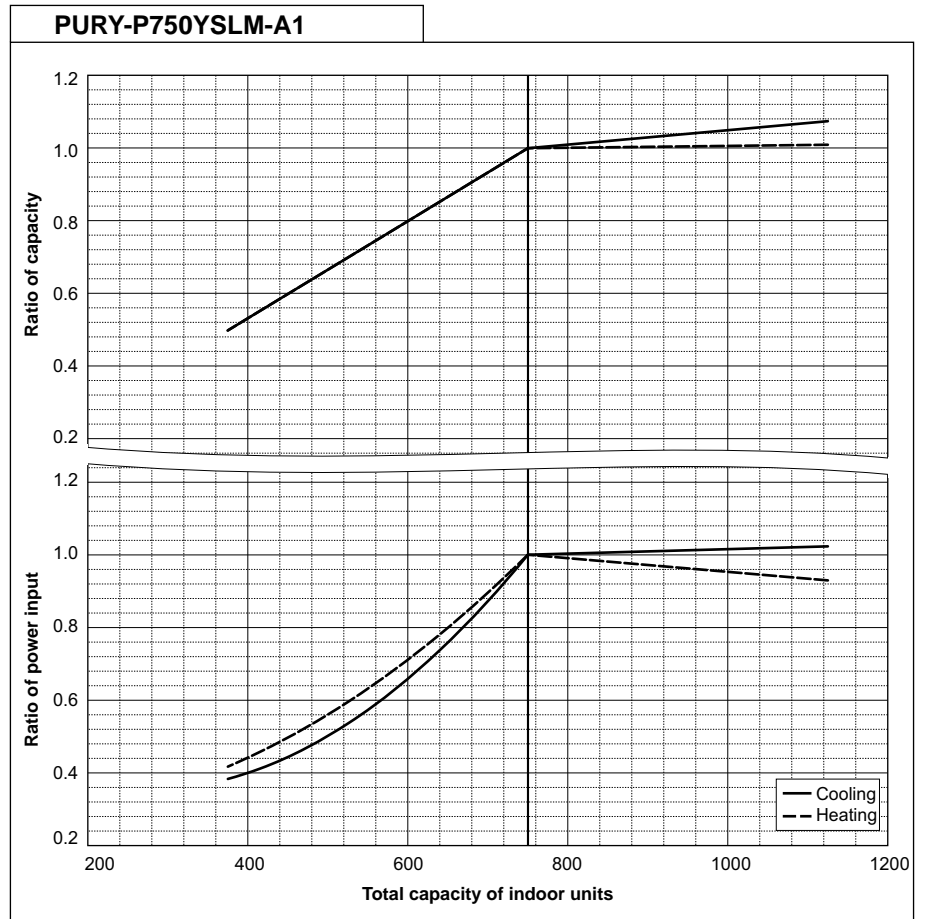

PURY-P800YSLM-A1		
Nominal Cooling Capacity	kW	90.0
	BTU/h	307,100
Input	kW	28.30

PURY-P800YSLM-A1		
Nominal Heating Capacity	kW	90.0
	BTU/h	307,100
Input	kW	22.84

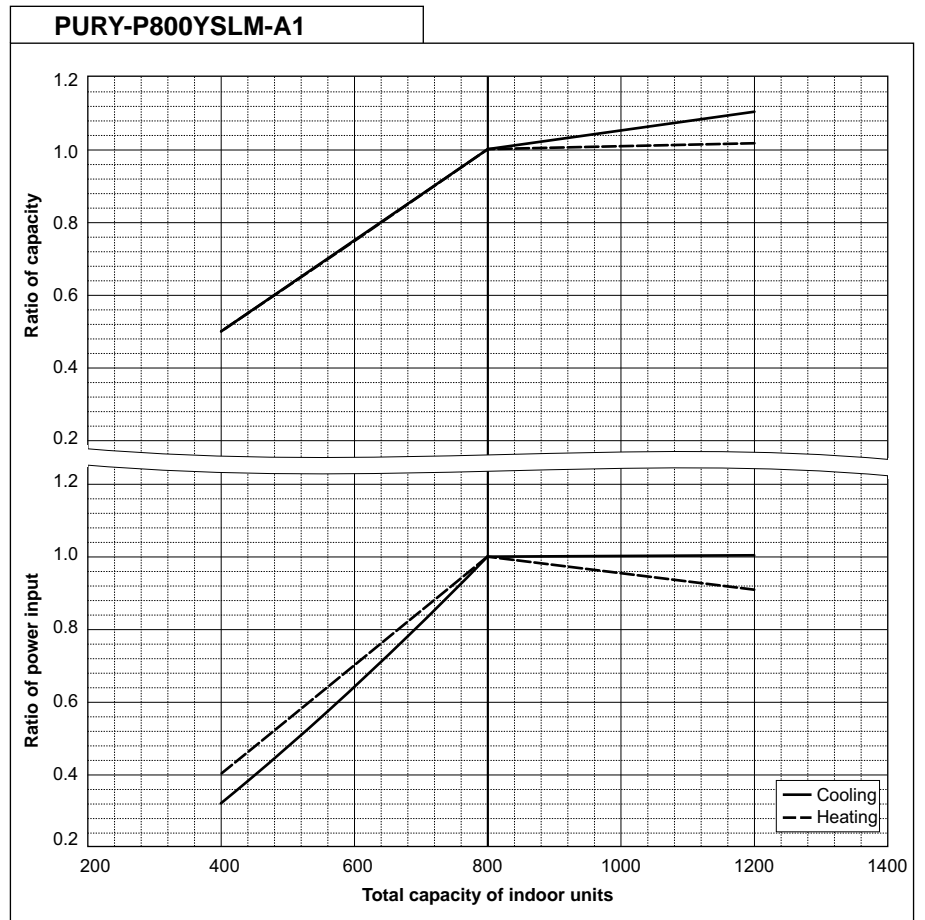

R2

R2

PURY-P850YSLM-A1		
Nominal Cooling Capacity	kW	96.0
	BTU/h	327,600
Input	kW	29.26

PURY-P850YSLM-A1		
Nominal Heating Capacity	kW	101.0
	BTU/h	344,600
Input	kW	26.23

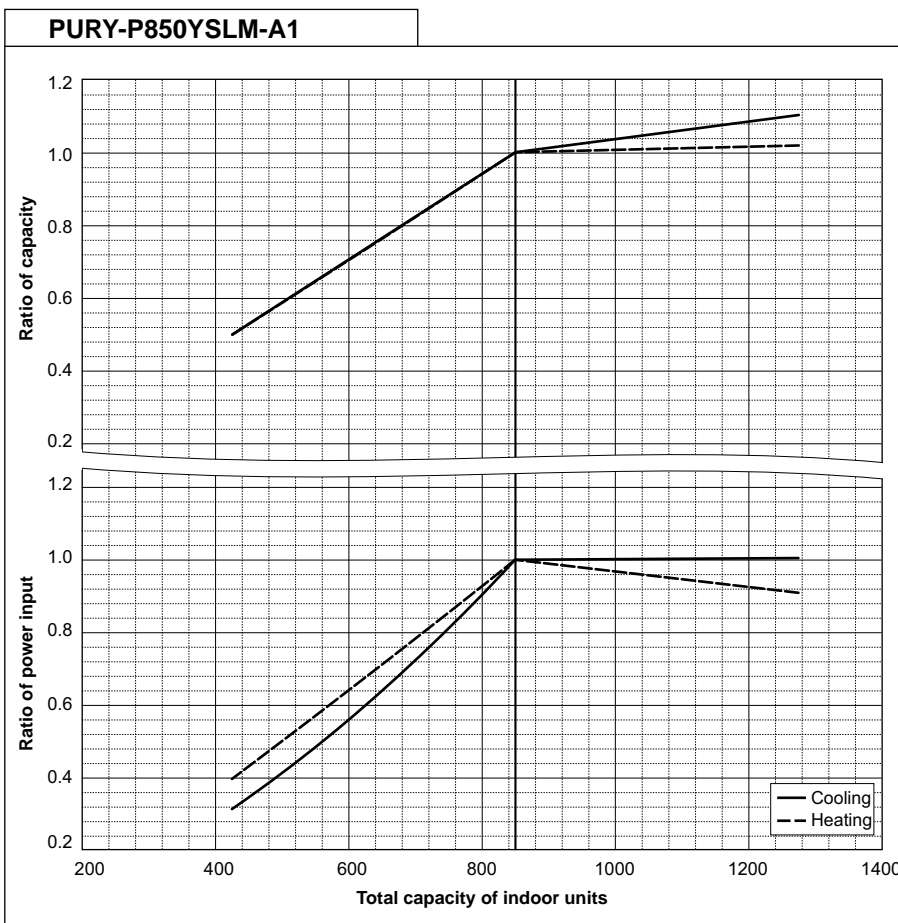

PURY-P900YSLM-A1		
Nominal Cooling Capacity	kW	101.0
	BTU/h	344,600
Input	kW	29.79

PURY-P900YSLM-A1		
Nominal Heating Capacity	kW	113.0
	BTU/h	385,600
Input	kW	30.13

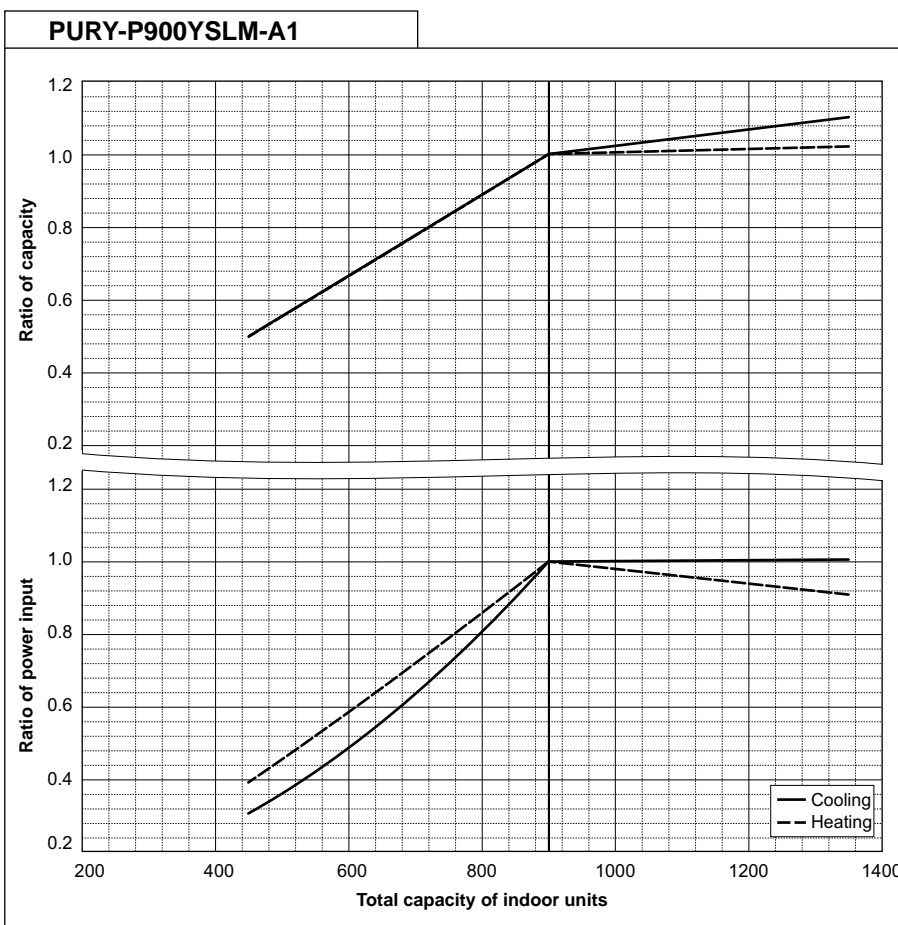

8-4. Correction by refrigerant piping length

CITY MULTI system can extend the piping flexibly within its limitation for the actual situation. However, a decrease of cooling/heating capacity could happen correspondently. Using following correction factor according to the equivalent length of the piping shown at 8-4-1 and 8-4-2, the capacity can be observed. 8-4-3 shows how to obtain the equivalent length of piping.

8-4-1. Cooling capacity correction

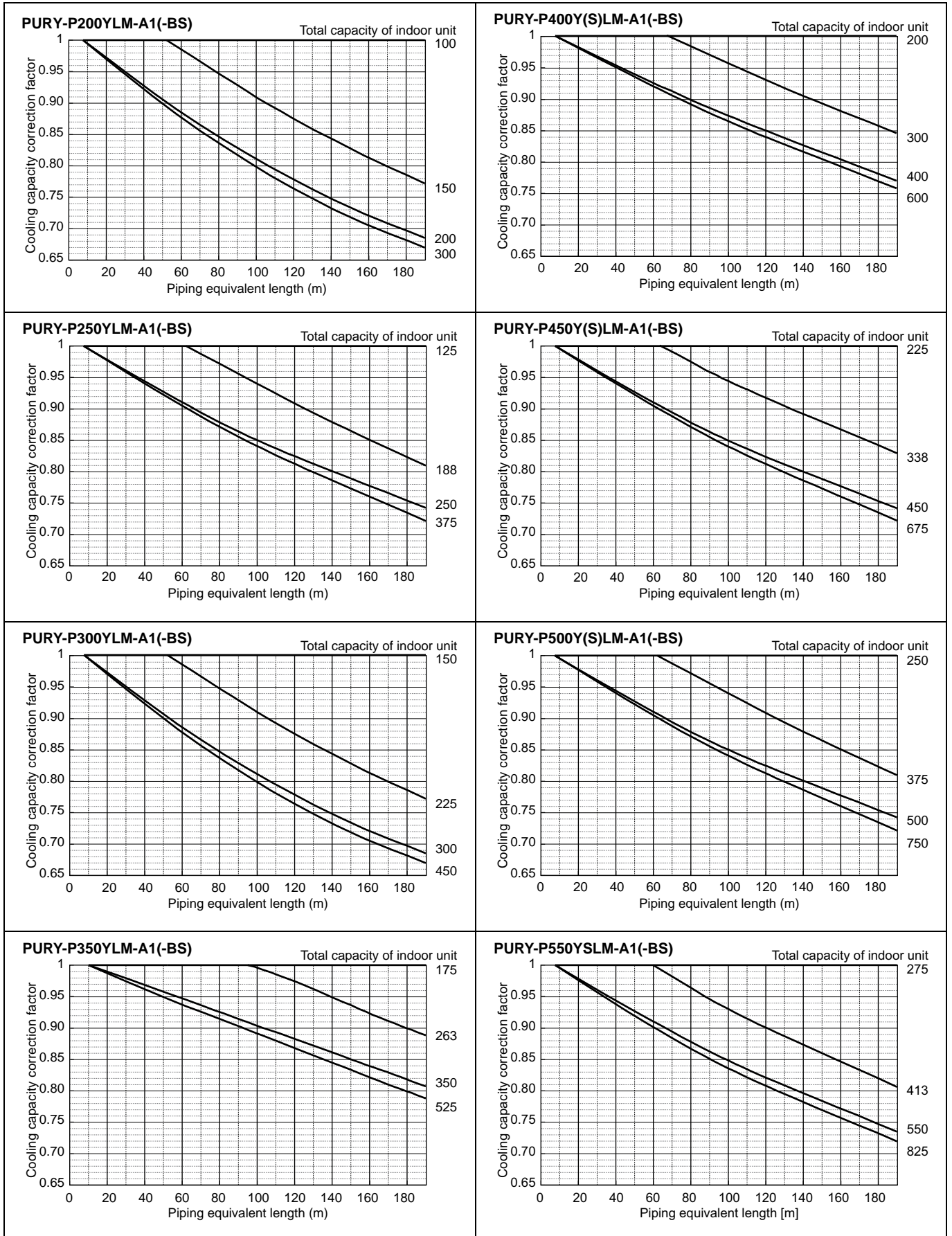

R2

8. CAPACITY TABLES

YKB/YLM

R2

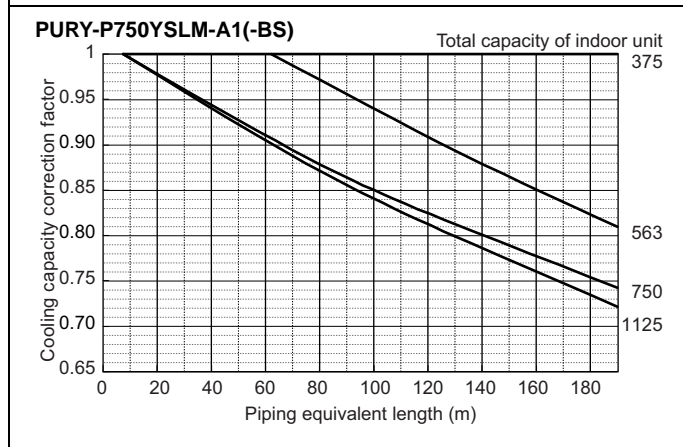
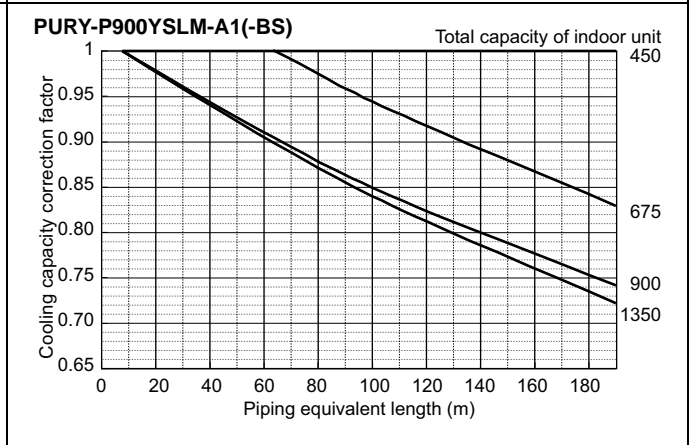
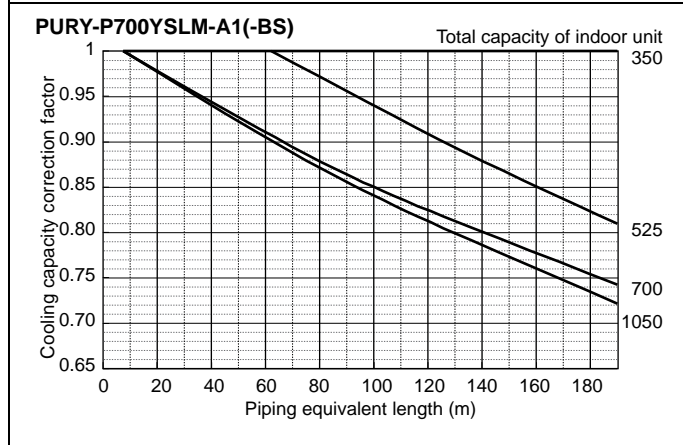
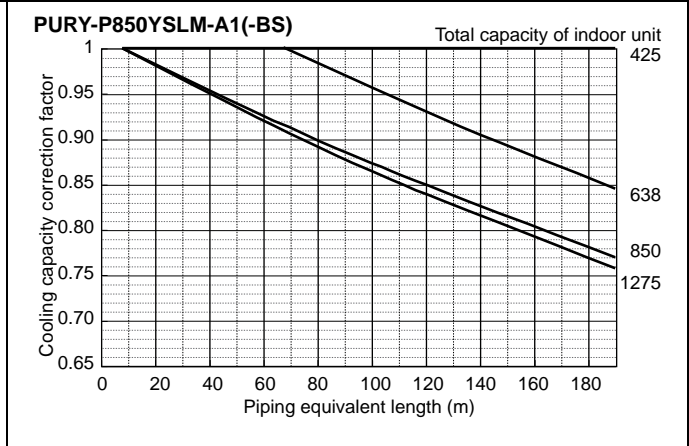
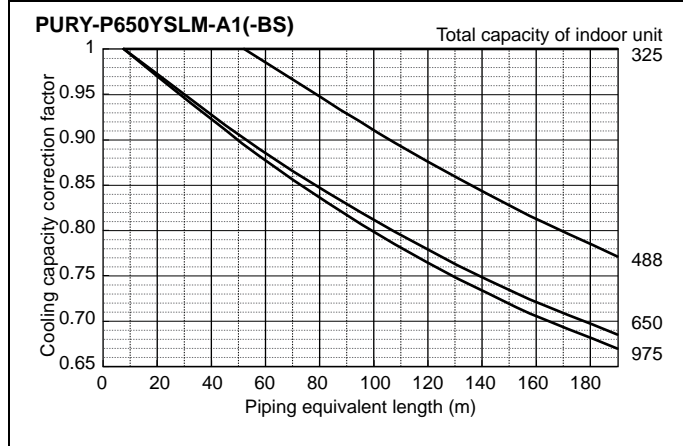
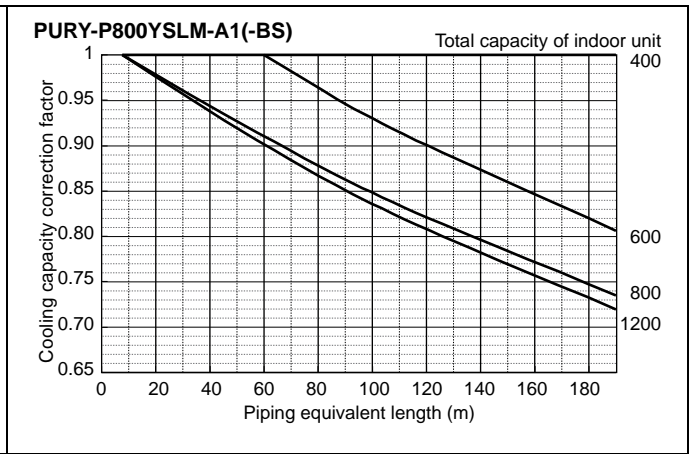
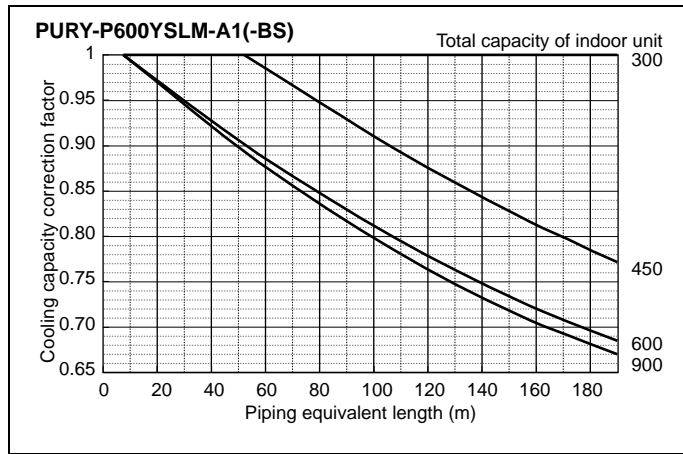

8-4-2. Heating capacity correction

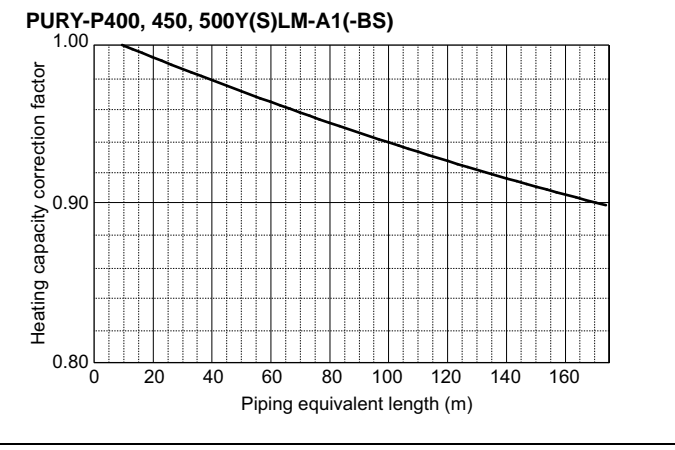
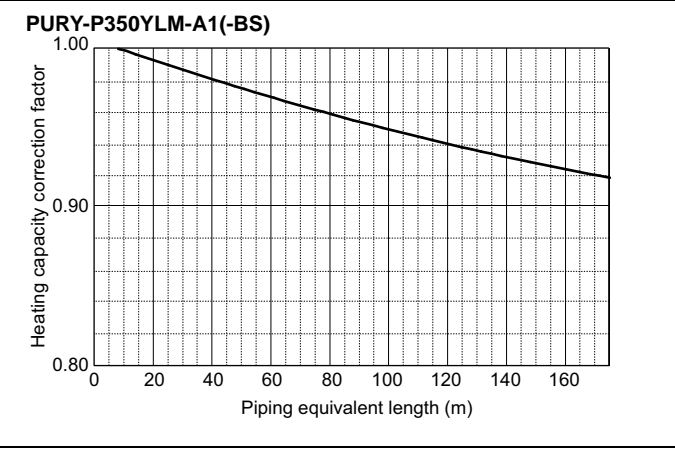
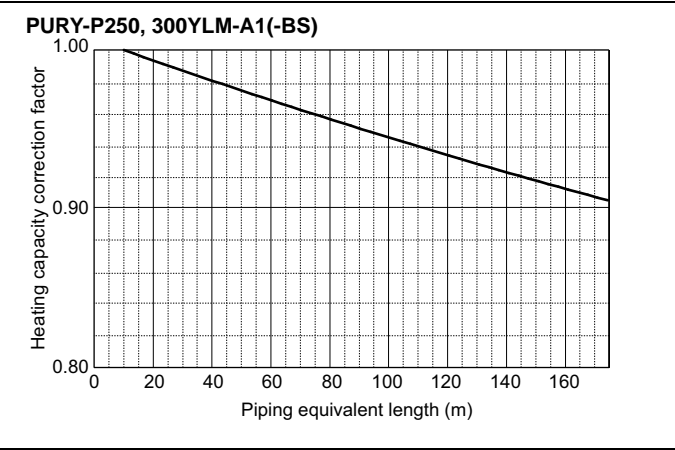
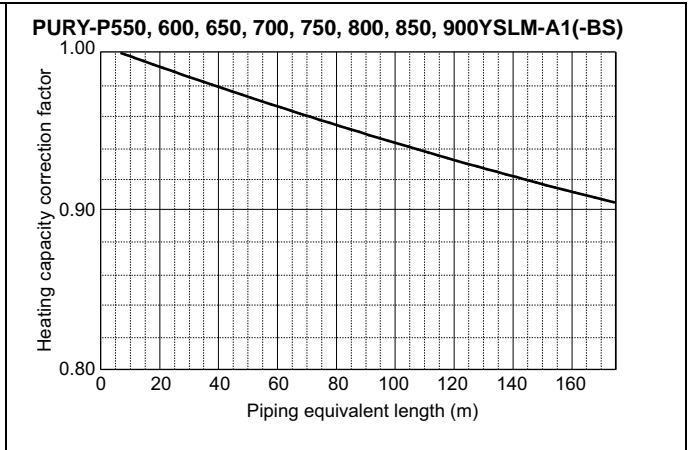
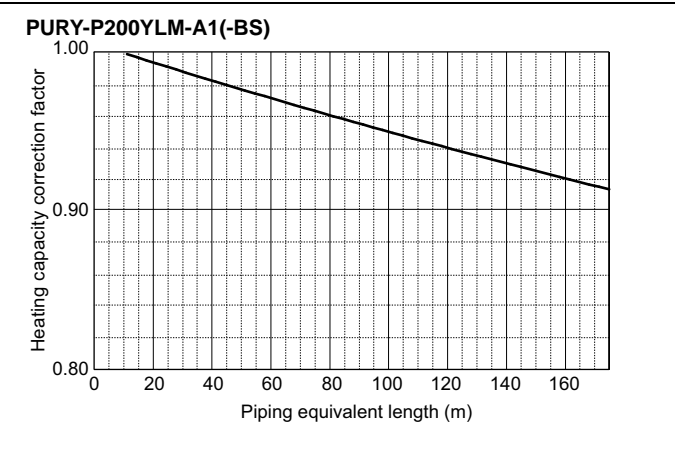

R2

8-4-3. How to obtain the equivalent piping length

- 1 **PURY-P200YLM-A1(-BS)**
Equivalent length = (Actual piping length to the farthest indoor unit) + (0.35 x number of bends in the piping) m
- 2 **PURY-P250, 300YLM-A1(-BS)**
Equivalent length = (Actual piping length to the farthest indoor unit) + (0.42 x number of bends in the piping) m
- 3 **PURY-P350YLM-A1(-BS)**
Equivalent length = (Actual piping length to the farthest indoor unit) + (0.47 x number of bends in the piping) m
- 4 **PURY-P400, 450, 500, 550, 600, 650Y(S)LM-A1(-BS)**
Equivalent length = (Actual piping length to the farthest indoor unit) + (0.50 x number of bends in the piping) m
- 5 **PURY-P700, 750, 800YSLM-A1(-BS)**
Equivalent length = (Actual piping length to the farthest indoor unit) + (0.70 x number of bends in the piping) m
- 6 **PURY-P850, 900YSLM-A1(-BS)**
Equivalent length = (Actual piping length to the farthest indoor unit) + (0.80 x number of bends in the piping) m

8-5. Correction by port counts of the BC controller

Indoor unit sizes P200 and P250 must be connected to 2 ports on the BC controller.

Indoor unit sizes from P100 to P140 should normally be connected to 2 ports on the BC controller (set BC controller DIP-SW 4-6 to its ON position).

In cases whereby indoor unit sizes from P100 to P140 are connected to only 1port on the BC controller (set BC controller DIP-SW 4-6 to its OFF position), the cooling capacity of the indoor unit should be multiplied by a correction factor of **0.97**.

8-6. Correction at frost and defrost

Due to frost at the outdoor heat exchanger and the automatic defrost operation, the heating capacity of the outdoor unit can be calculated by multiplying the correction factor shown in the table below.

Table of correction factor at frosting and defrosting

Outdoor inlet air temp. °C	6	4	2	1	0	-2	-4	-6	-8	-10	-20
Outdoor inlet air temp. °F	43	39	36	34	32	28	25	21	18	14	-4
PURY-P200YLM-A1(-BS)	1.00	0.95	0.84	0.83	0.83	0.87	0.90	0.95	0.95	0.95	0.95
PURY-P250YLM-A1(-BS)	1.00	0.95	0.84	0.83	0.83	0.87	0.90	0.95	0.95	0.95	0.95
PURY-P300YLM-A1(-BS)	1.00	0.93	0.82	0.80	0.82	0.86	0.90	0.90	0.95	0.95	0.95
PURY-P350YLM-A1(-BS)	1.00	0.93	0.85	0.83	0.84	0.86	0.90	0.90	0.95	0.95	0.95
PURY-P400Y(S)LM-A1(-BS)	1.00	0.95	0.90	0.87	0.88	0.89	0.90	0.95	0.95	0.95	0.95
PURY-P450Y(S)LM-A1(-BS)	1.00	0.98	0.89	0.87	0.89	0.90	0.92	0.95	0.95	0.95	0.95
PURY-P500Y(S)LM-A1(-BS)	1.00	0.98	0.89	0.86	0.89	0.90	0.92	0.95	0.95	0.95	0.95
PURY-P550YSLM-A1(-BS)	1.00	0.94	0.87	0.86	0.87	0.88	0.90	0.90	0.93	0.93	0.93
PURY-P600YSLM-A1(-BS)	1.00	0.94	0.84	0.86	0.87	0.88	0.90	0.90	0.93	0.93	0.93
PURY-P650YSLM-A1(-BS)	1.00	0.94	0.84	0.86	0.87	0.88	0.90	0.90	0.93	0.93	0.93
PURY-P700YSLM-A1(-BS)	1.00	0.98	0.89	0.88	0.89	0.90	0.92	0.95	0.95	0.95	0.95
PURY-P750YSLM-A1(-BS)	1.00	0.98	0.89	0.88	0.89	0.90	0.92	0.95	0.95	0.95	0.95
PURY-P800YSLM-A1(-BS)	1.00	0.98	0.89	0.88	0.89	0.90	0.92	0.95	0.95	0.95	0.95
PURY-P850YSLM-A1(-BS)	1.00	0.98	0.89	0.88	0.89	0.90	0.92	0.95	0.95	0.95	0.95
PURY-P900YSLM-A1(-BS)	1.00	0.98	0.89	0.88	0.89	0.90	0.92	0.95	0.95	0.95	0.95

9-1. JOINT

CITY MULTI units can be easily connected by using Joint sets and Header sets provided by Mitsubishi Electric. Three kinds of Joint sets are available for use. Refer to section 3 in "System Design" or the Installation Manual that comes with the Joint set for how to install the Joint set.

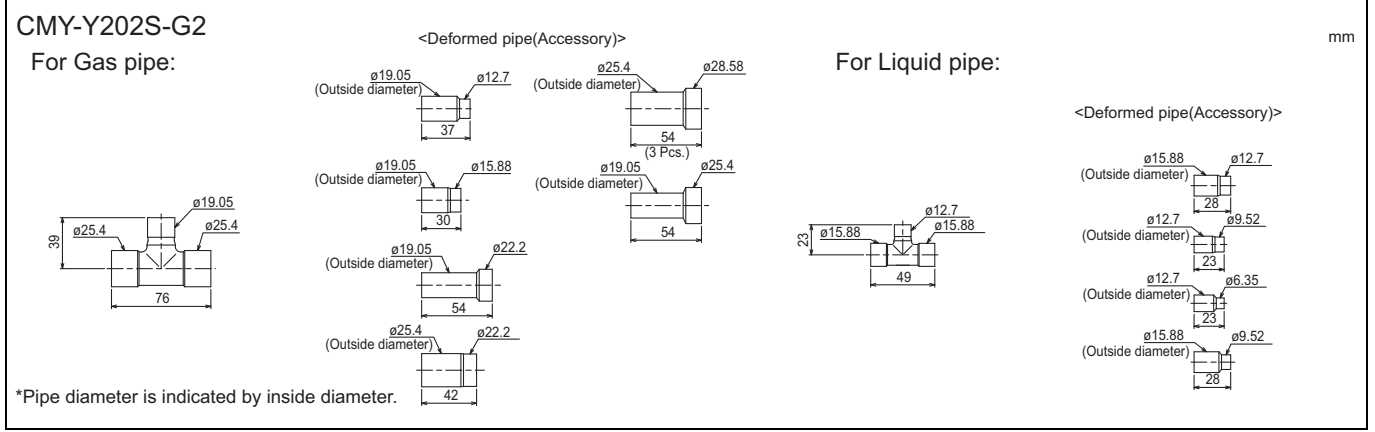
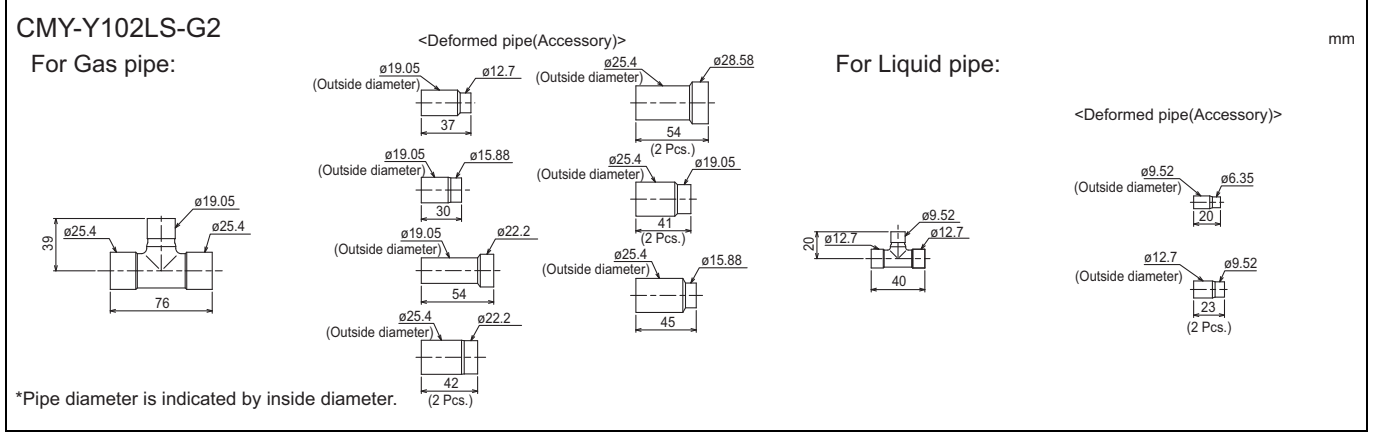
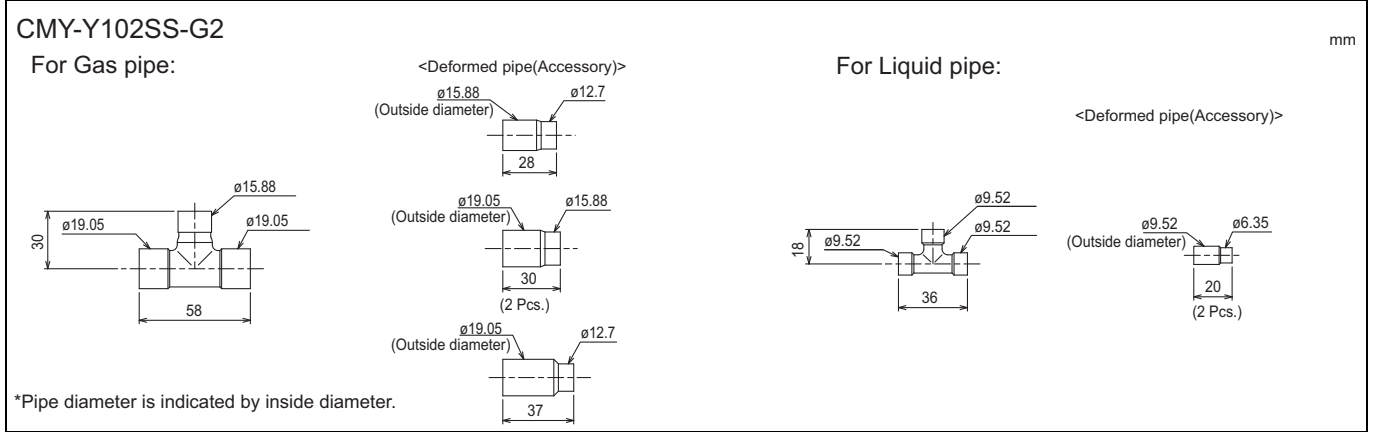

9-2. OUTDOOR TWINNING KIT

The following optional Outdoor Twinning Kit is needed to use to combine multiple refrigerant pipes. Refer to the chapter entitled System Design Section for the details of selecting a proper twinning kit.

R2

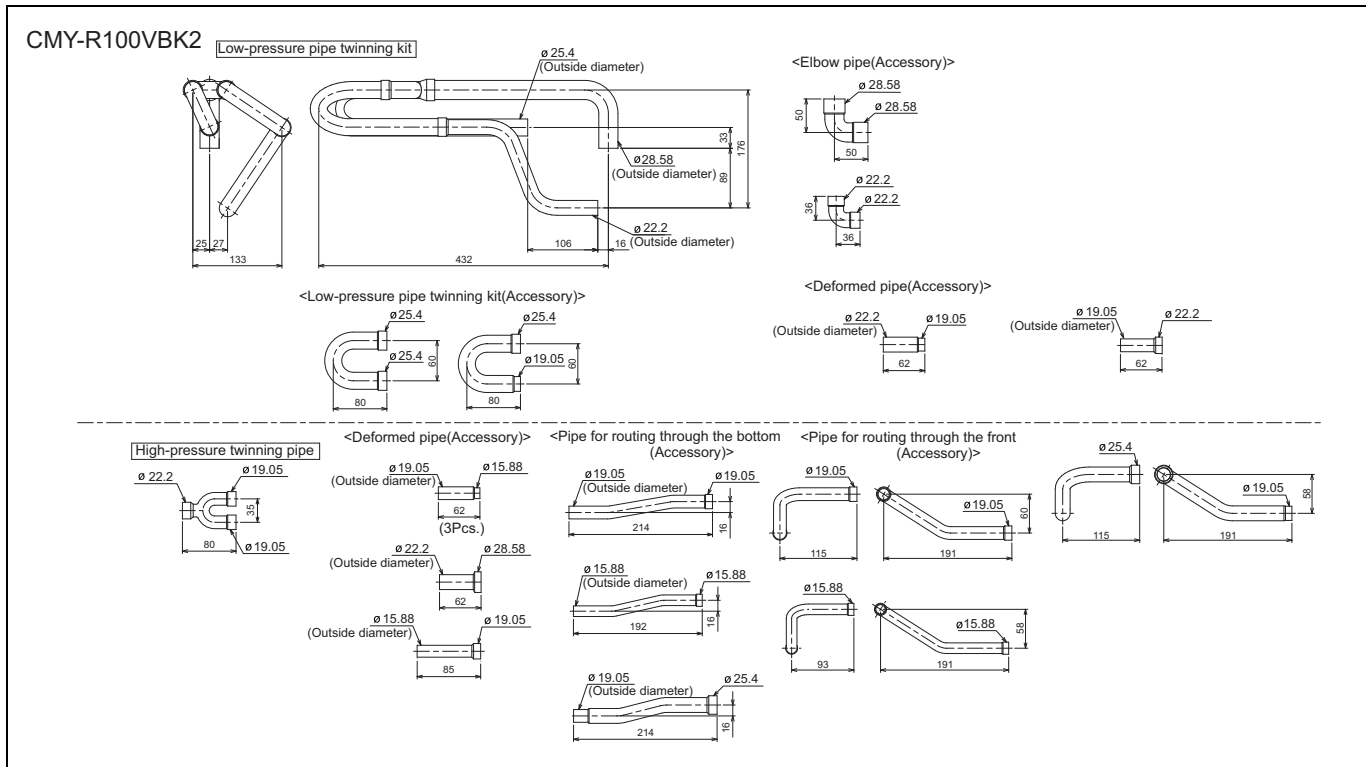
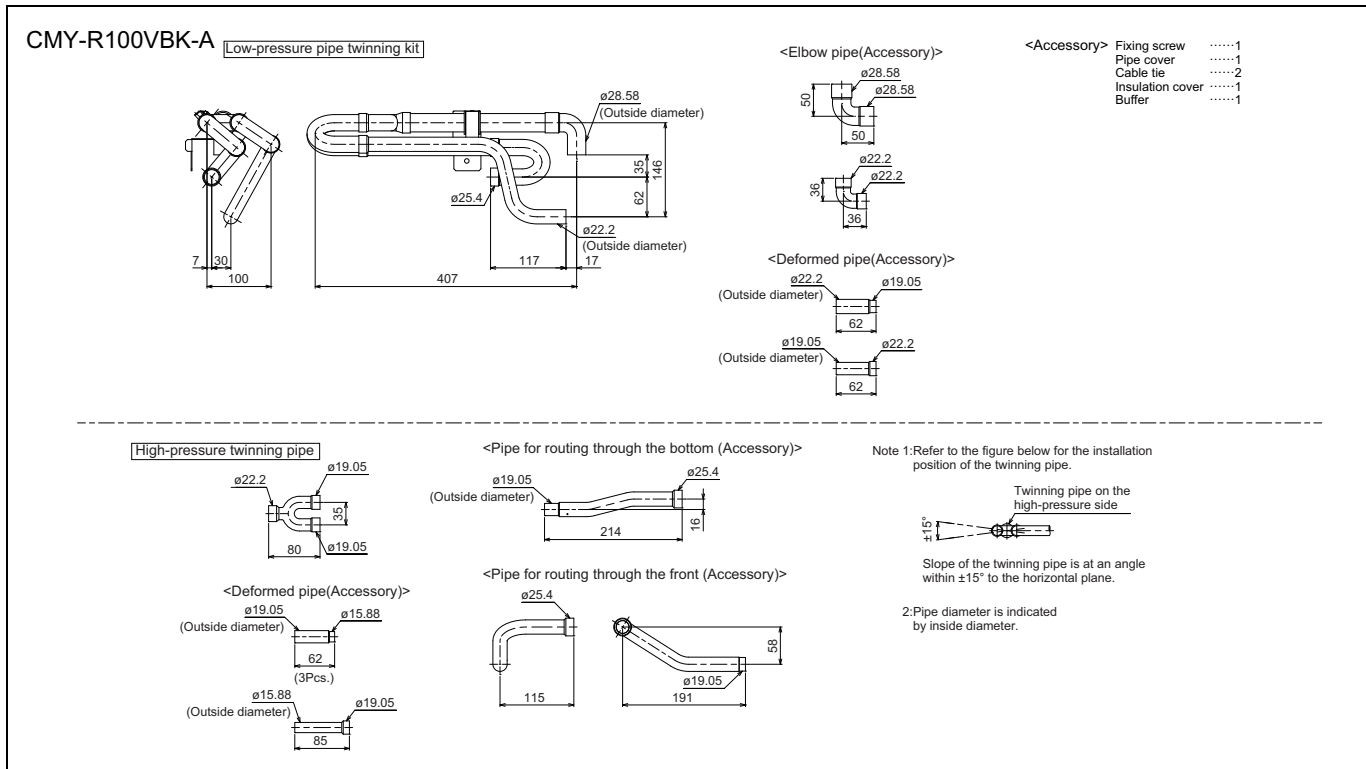

Note 1. Refer to the figure below for the installation position of the twinning pipe.

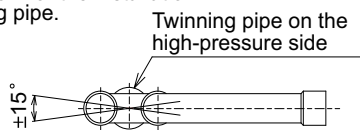

Slope of the twinning pipe is at an angle within $\pm 15^\circ$ to the horizontal plane.

2. Use the attached pipe to braze the port-opening of the distributor.
3. Pipe diameter is indicated by inside diameter.
4. Only use the Twinning pipe by Mitsubishi (optional parts).

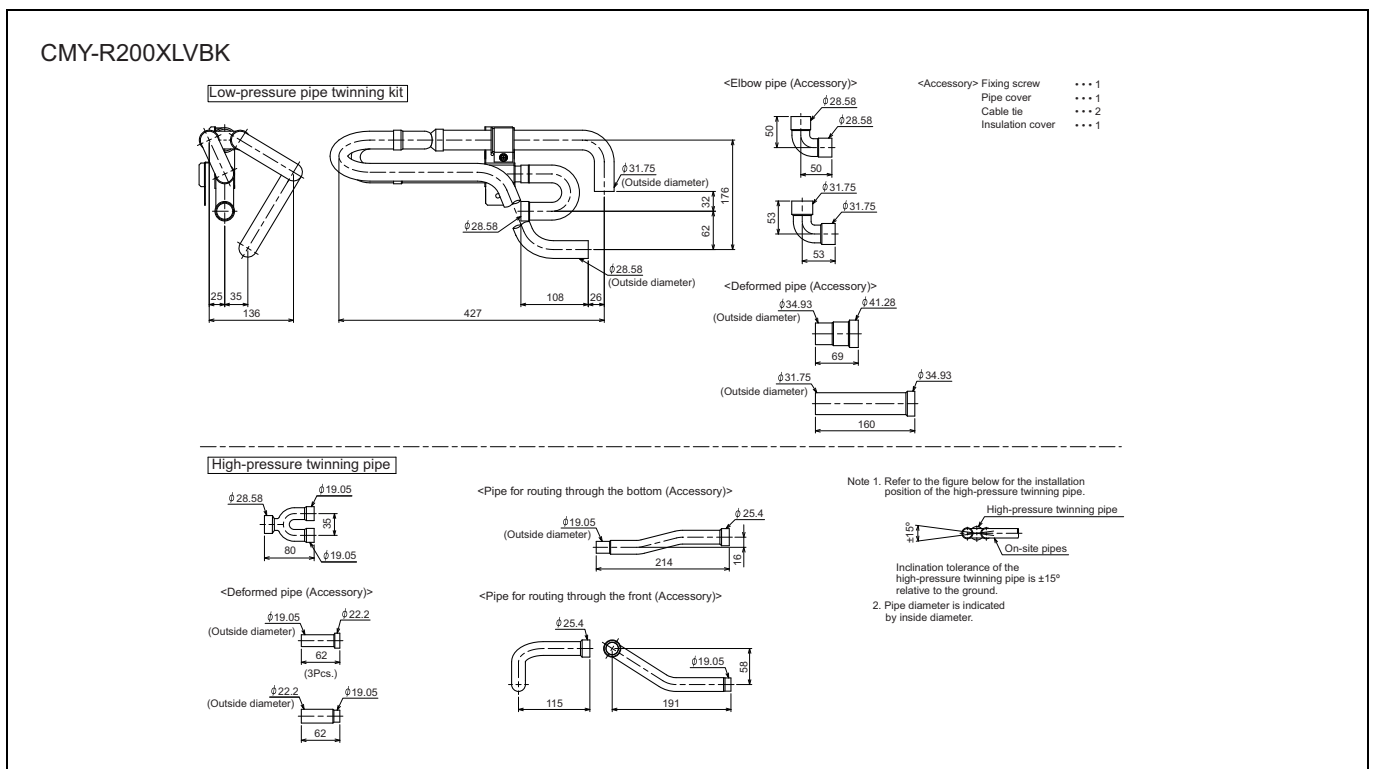
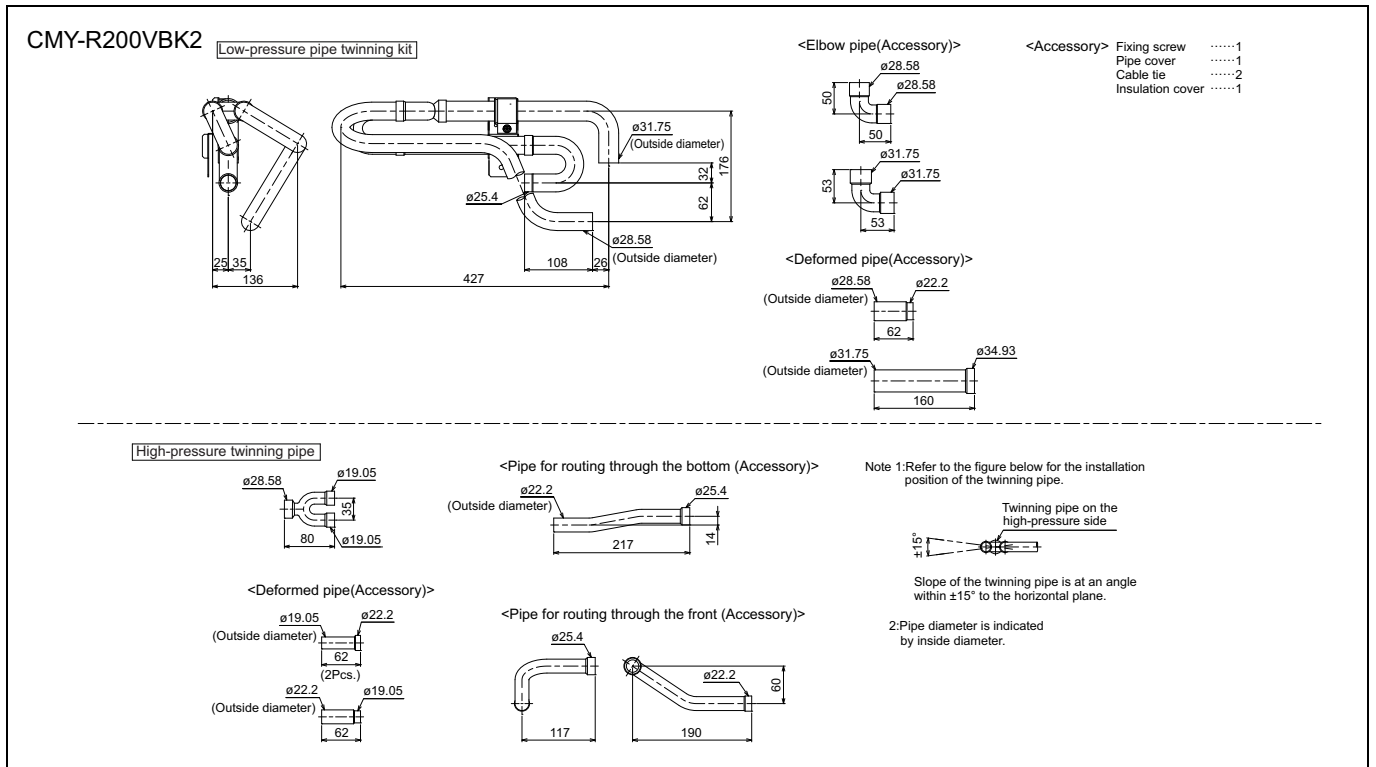

Note 1. Refer to the figure below for the installation position of the twinning pipe.

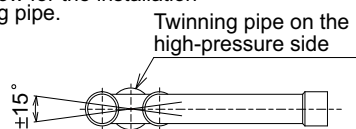

Slope of the twinning pipe is at an angle within $\pm 15^\circ$ to the horizontal plane.

2. Use the attached pipe to braze the port-opening of the distributor.
3. Pipe diameter is indicated by inside diameter.
4. Only use the Twinning pipe by Mitsubishi (optional parts) .

9-3. JOINT KIT "CMY-R160-J1" FOR BC CONTROLLER

Joint kit "CMY-R160-J1" for BC controller is used to combine 2 ports of the BC controller at a PURY-(E)P-Y(S)LM-A(1) system so as to enable down-stream Indoor capacity above P80 as shown in Fig. 1.

The Joint kit include following items:

① Instruction	② Joint pipe(Small)	③ Joint pipe(Large)	④ Cover 1	⑤ Cover 2	⑥ Cover 3	⑦ Band	⑧ Reducer 1	⑨ Reducer 2
This sheet 1pc	1pc	1pc	2pcs	1pc for gas side	1pc for liquid side	8pcs	OD19.05-ID22.2 1pc	OD19.05-ID15.88 1pc

Please prepare the following items in the field. ① Tape for insulation material sealing ② Extension pipe for refrigerant circuit

② Joint pipe (for liquid side)

③ Joint pipe (for gas side)

mm(in.)

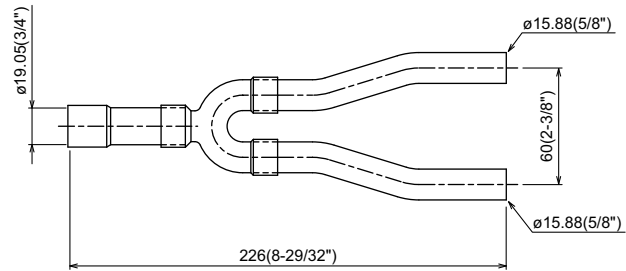
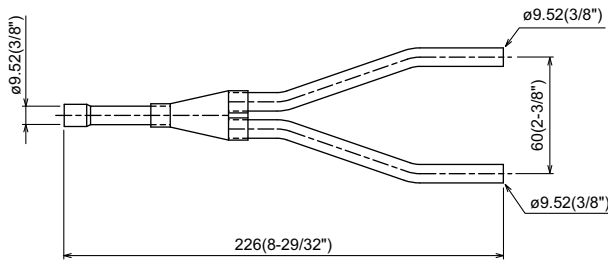

1. Designing CMY-R160-J1 to a PURY-(E)P-Y(S)LM-A(1) system

The maximum down-stream Indoor capacity for 1 port of BC controller is P80. When the down-stream Indoor capacity is above P80, Joint kit CMY-R160-J1 is needed to combined 2 ports of BC controller to enlarge the capacity, like Group 2 and 3 in Fig. 1.

Maximum 3 Indoor units are allowed to connect to 1 port of BC controller or 2 combined ports of BC controller using CMY-R160-J1.

When connecting Indoor units to 1 port of BC controller or 2 combined ports of BC controller using CMY-R160-J1 or CMY-Y102SS-G2 is applicable, like Group 1 and 2 in Fig. 1

Caution: Mixed cooling and heating mode at the same time for Indoor units connecting to 1 port or 2 combined ports is not available.

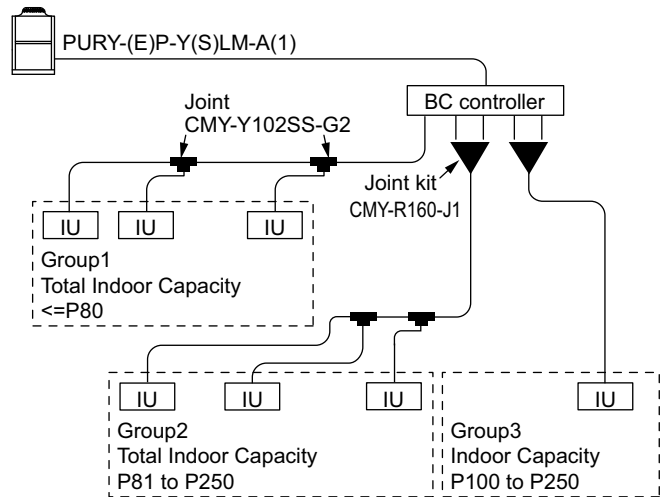

Fig.1. CMY-R160-J1 applying scheme

2. Piping at the installation site

The connection of CMY-R160-J1 to BC controller and pipe leading to Indoor units is referable to Fig. 2. Non-oxidized brazing is necessary. All piping must be careful to avoid foreign material getting inside.

After piping and air-tight testing, insulation work to the Joint and pipe should be done. Details is available at the Installation Manual.

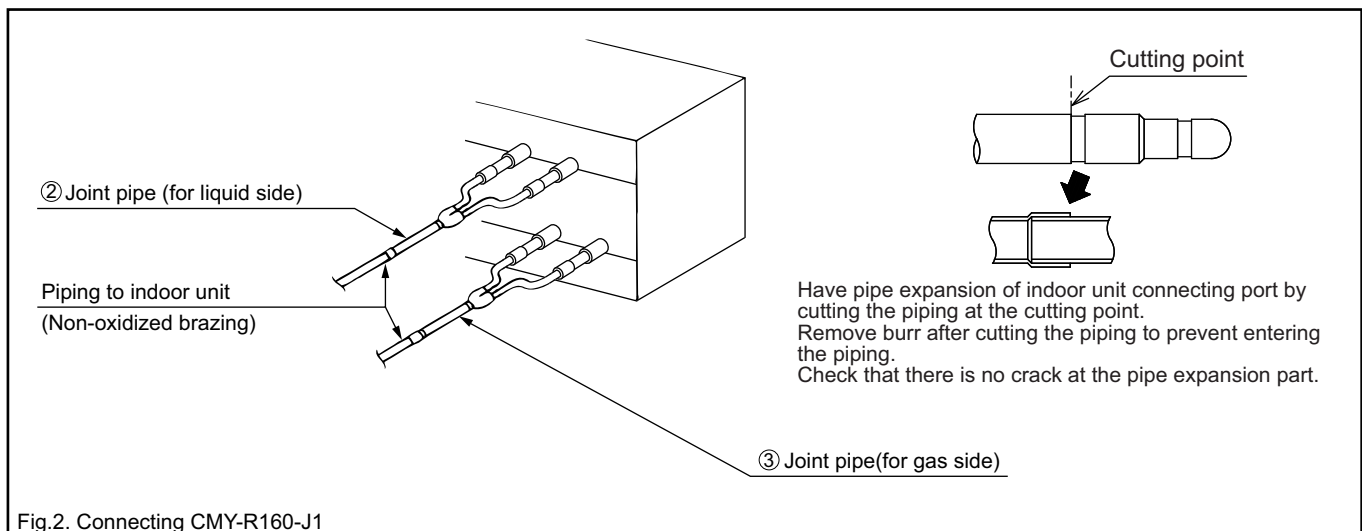
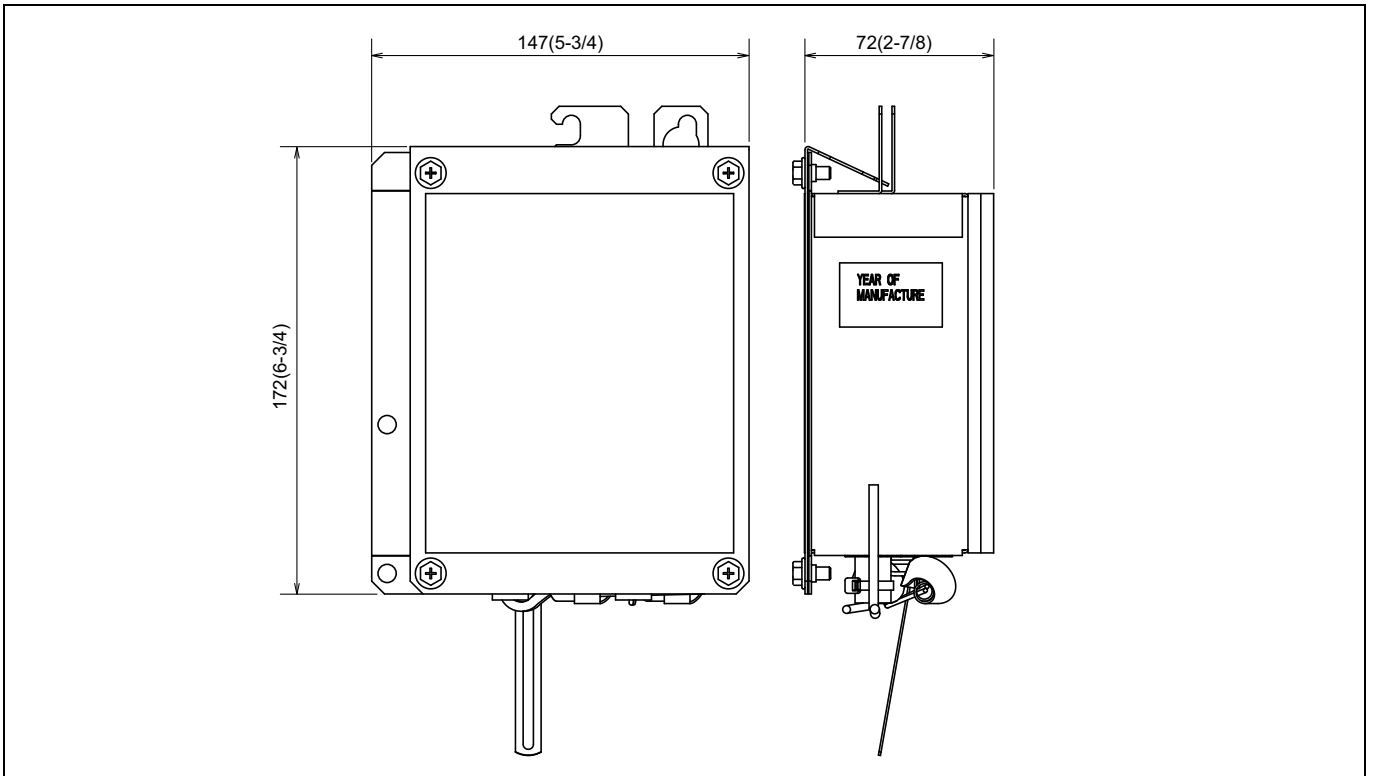

Fig.2. Connecting CMY-R160-J1

9-4. RELAY BOX

If there is a risk that the drain water will freeze inside the outdoor unit, the installation of a base heater is recommended. PAC-BH02KTY-E is a relay box for controlling the electric base heater. For details, refer to the relay box Installation Manual.



R2

9-5. BASE HEATER

If there is a risk that the drain water will freeze inside the outdoor unit, the installation of a base heater is recommended. For details, refer to the base heater Installation Manual.

R2

PAC-BH04EHT-E (for S module)

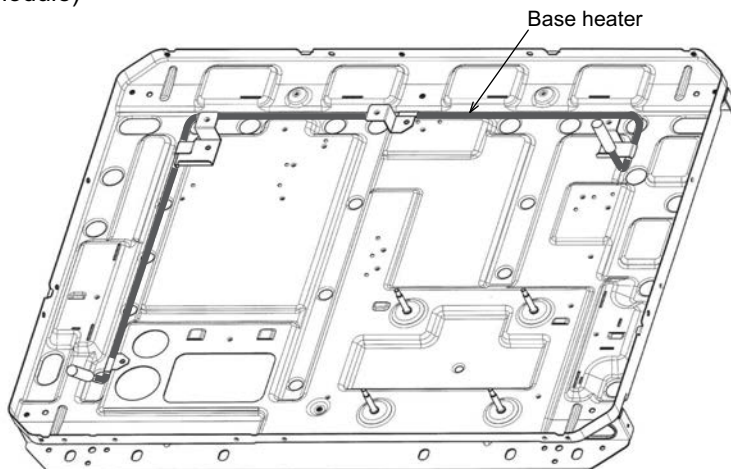

PAC-BH05EHT-E (for L module)

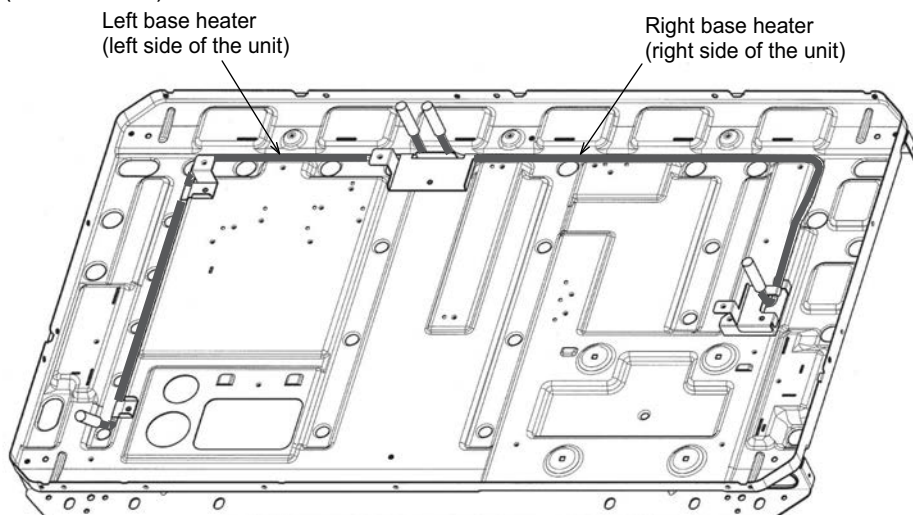

PAC-BH06EHT-E (for XL module)

