

Air-conditioner Network System

Centralized Controller

AG-150A

GB-50ADA-A

GB-50ADA-J

Instruction Book

(Web browser for Initial Settings)

Contents

1 Introduction	1
1-1 Terms Used in This Manual	1
1-2 Computer Requirements	1
1-3 Notes on using AG-150A with the integrated centralized control software (TG-2000A).....	1
2 Setting the Operating Environment	2
2-1 Setting the PC IP Address.....	2
2-2 Setting the Web Browser.....	4
2-3 Setting the Java Execution Environment.....	6
3 Performing Operations	7
3-1 Logging in on the AG-150A	7
4 Initial Settings.....	10
4-1 Setting the Current Date and Time.....	10
4-2 Setting the Basic Information and External Input Functions .	11
4-3 Group Setting	19
4-4 Interlocked Setting.....	21
4-5 Block Setting.....	22
5 Functions 1	23
5-1 Error mail reports/E-mail communication	23
5-2 Energy-Save Control and Peak Cut Control	26
5-3 Settings for measurement	31
6 Functions 2.....	35
6-1 Limiting the Set Temperature Operating Range	35
6-2 Night Mode (Silent Mode) Schedule.....	36
6-3 System-Changeover of Y series.....	37
7 Functions 3.....	38
7-1 External Temperature Interlock	38
7-2 Night setback control	39
7-3 Interlock control	40
8 User Setting	48
9 Registering a License for Optional Function	50

Before using the controller, please read this Instruction Book carefully to ensure correct operation. Retain this manual for future reference.

1 Introduction

Special features of Mitsubishi Electric Corporation’s “Centralized Controller AG-150A,” “Centralized Controller GB-50ADA-A,” and “Centralized Controller GB-50ADA-J” are that a PC connected to a LAN can be used to monitor the operation condition of air conditioners, perform air conditioner operations, and make initial settings. This document explains the procedures for making initial settings for the Centralized Controller using the web browser. Hereinafter, the centralized controller AG-150A, GB-50ADA-A, and GB-50ADA-J, unless otherwise specified, will be called "AG-150A".

Note: License of "Web Monitor" or "Basic License Pack" is necessary to use the web browser (to operate or monitor the air conditioners). Some licenses are necessary depending on the functions to be used. Register the license key on the LCD screen or on the registration screen.

Note: A one-day license key can be registered on the LCD screen that allows the user to use the "Web Monitor" only on the day of the registration (not applicable to GB-50ADA-A and GB-50ADA-J). Use this license key to use the initial setting browser, or in any other situations when a temporary license key "Web Monitor" is necessary.

Note: Use a security device such as a VPN router when connecting the AG-150A to the Internet to prevent unauthorized access.

Note: "Booster unit" and "Water HEX unit" are referred to as "Air to water".

Note: As GB-50ADA-A and GB-50ADA-J are not equipped with a LCD for settings, the initial setting must be made on the Initial Setting Web.

Note: GB-50ADA-A and GB-50ADA-J cannot be connected to the Expansion Controller (PAC-YG50ECA). Settings or displays of the Expansion Controller cannot be made on the GB-50ADA-A and GB-50ADA-J.

1-1 Terms Used in This Manual

- “Click” refers to the action of positioning the mouse cursor on the object (such as button or folder), pressing down, and releasing the left mouse button once.
- Unless otherwise specified, the example screen images used in this manual are Windows XP® and Internet Explorer 6.0 screen images.

Note: Windows is a registered trademark or trademark of Microsoft Corporation USA in the United States and other countries.

1-2 Computer Requirements

To monitor and operate air conditioners by web browser, computer must include the following requirements.

Table 1-1 Computer Requirements

Item	Requirement
CPU	Pentium 300MHz or faster
Memory	64M Bytes or more (128M Bytes or more recommended)
Screen resolution	1024 x 768 or higher recommended
Compatible browser	Microsoft® Internet Explorer 6.0 or later Note: You must have a Java execution environment (Sun Microsystems Java® Plug-in Ver.1.6.0.02 or later). Note: You can check the Sun Microsystems® Java Plug-in version in “Java” in a control panel. Note: When using Sun Microsystems® Java Plug-in Ver.1.6.0_10 or later, set the Java execution environment according to the instructions in section 2-3 “Setting the Java Execution Environment.”
On-board LAN port or LAN card	One connector (100BASE-TX)
Other	Pointing device such as a mouse

Note: Microsoft is a registered trademark or trademark of Microsoft Corporation USA in the United States and other countries.

Sun Microsystems and Java are trademarks or registered trademarks of Sun Microsystems Inc. in the United States and/or other countries.

1-3 Notes on using AG-150A with the integrated centralized control software (TG-2000A)

If the system is connected to the integrated centralized control software (referred to as TG-2000A hereafter), make all settings and changes from the TG-2000A so that the data in TG-2000A and AG-150A will match.

2 Setting the Operating Environment

PC settings and web browser settings required for using a web browser to monitor air conditioner units and perform operations are explained in the following pages.

2-1 Setting the PC IP Address

Set an IP address on the PC that enables AG-150A to connect via a web browser. For instance, if the AG-150A IP address is [192.168.1.1], the PC IP address will need to belong to the same system [192.168.1.101].

If the AG-150A is connected to an existing LAN, ask the LAN administrator to decide what PC IP address to use.

Note: When using a AG-150A dedicated LAN, it is recommended that the AG-150A main unit be given an IP address within the range [192.168.1.1] - [192.168.1.40] and the PCs that will be connected to the AG-150A be given an IP address within the range [192.168.1.101] - [192.168.1.150]

(1) Click on [Control Panel] under [Start] to open the Control Panel.

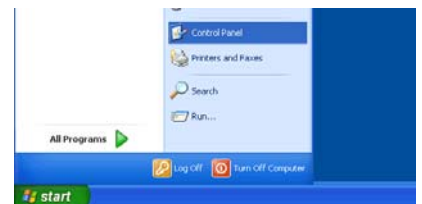

(2) In the Control Panel window, double click [Network and Dial-up Connections] and the Network and Dial-up Connections window will open. Double click on [Local Area Setting] and the [Local Area Connection Status] dialog will open. Click [Properties].

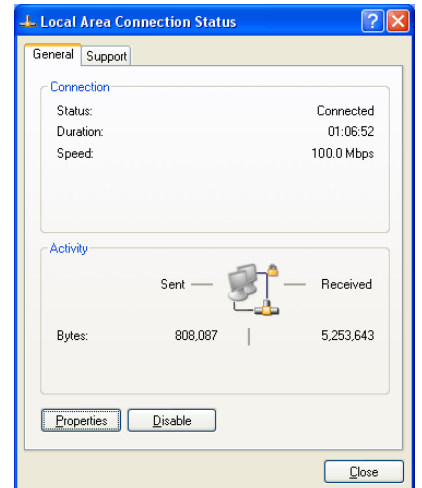

(3) In the [Local Area Connection Properties] dialog, click [Internet Protocol] to select it and click the [Properties] button.

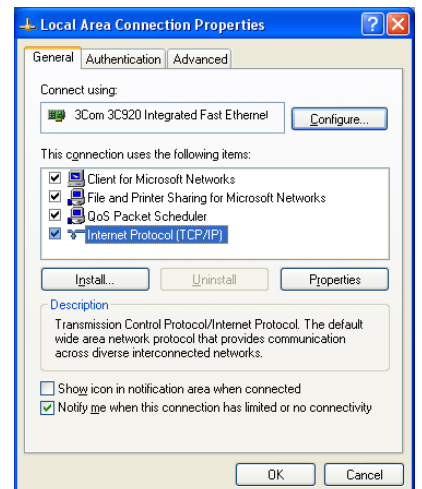

(4) In the [Internet Protocol (TCP/IP) Properties] dialog, click [Use the following IP address] and enter the IP address (for example, “192.168.1.101”) that you want to set in the IP address field.

You normally set [255.255.255.0] as the subnet mask.

Note: Ask your LAN administrator to provide the IP addresses and subnet mask.

(5) Click the [OK] button to close this dialog, and then close the other open dialogs to complete the network setting.

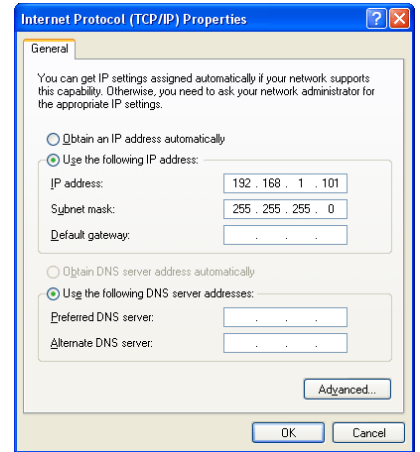

2-2 Setting the Web Browser

Use a security device such as a VPN router when connecting the AG-150A to the Internet to prevent unauthorized access.

If no security devices are installed, the operation settings may be changed by an unauthorized person without the knowledge of the user.

Necessary web browser settings must be performed to enable the web browser to connect to the AG-150A.

Note: The settings and screen images used as examples in this manual are based on Internet Explorer 6.0.

2-2-1 No Internet Connection

Follow the instructions below to make the web browser environment settings when using the PC with no Internet connection for monitoring and operating the air conditioners.

(1) Click the web browser menu item [Tools] and then click [Internet Options...] to select.



(2) In the [Internet Options] tabbed dialog, click the [Connections] tab to display.

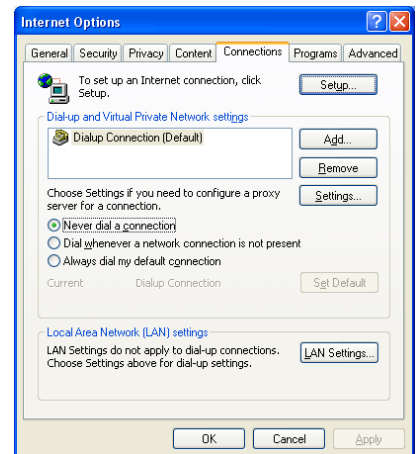

(3) Select [Never dial a connection] in the Dial-up settings section and click the [OK] button to close the dialog.

2-2-2 Internet Connection Using a Dial-Up

If the PC used for monitoring air conditioners and performing operations is going to connect to the Internet via a dial-up connection, use the procedure given below to set the web browser environment settings.

By performing these settings, a message will appear asking whether or not to use a dial-up connection when an Internet connection is necessary. When connecting to the Internet, follow the directions below.

(1) Click the web browser menu item [Tools] and then click [Internet Options...] to select.



(2) In the [Internet Options] tabbed dialog, click the [Connections] tab to display.

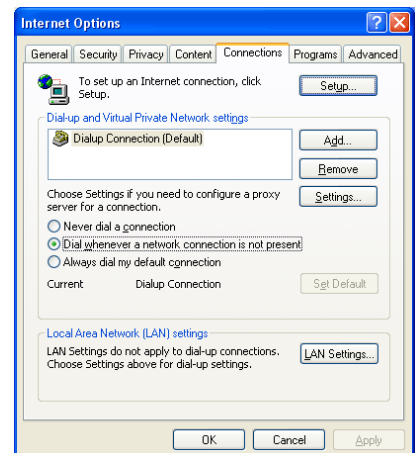

(3) Select [Dial whenever a network connection is not present] in the Dial-up settings section and click the [OK] button to close the dialog.

2-2-3 Connecting to the Internet using a proxy server (Using an existing LAN)

If the PC you use for monitoring air conditioners and performing operations is going to access the Internet via proxy server by connecting to an existing LAN such as a LAN within your company, use the procedure given below to set the web browser environment settings.

By performing these settings, your PC will connect to a proxy server only when connecting to the Internet.

- (1) Click the web browser menu item [Tools] and then click [Internet Options...] to select.



- (2) In the [Internet Options] tabbed dialog, click the [Connections] tab to display.

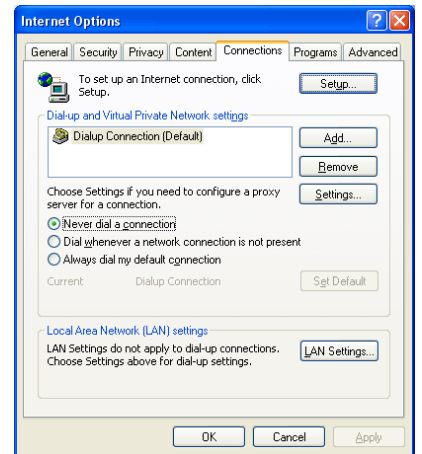

- (3) Select [Never dial a connection] in the Dial-up setting section.
- (4) Click the [LAN Setting . . .] button in the Local Area Network (LAN) settings section to display the Local Area Network (LAN) Settings dialog.

- (5) In the Local Area Network (LAN) Settings dialog, check [Bypass proxy server for local addresses] and click the [Advanced...] button.

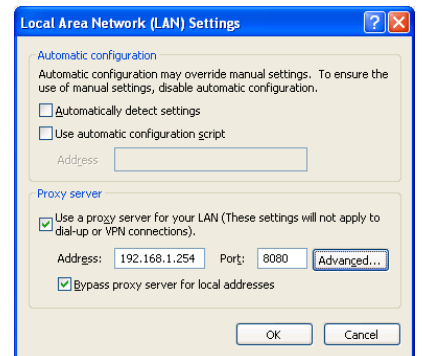

- (6) Enter the IP address for the AG-150A (e.g. 192.168.1.1) in the Exceptions field of the Proxy Setting dialog and click the [OK] button to close the dialog and then close the other open dialogs to complete the setting.

Note: If connecting to more than one AG-150A, you can specify multiple IP addresses like [192.168.1.1; 192.168.1.2], however, it is also possible to use the asterisk (*) and specify [192.168.1.*].

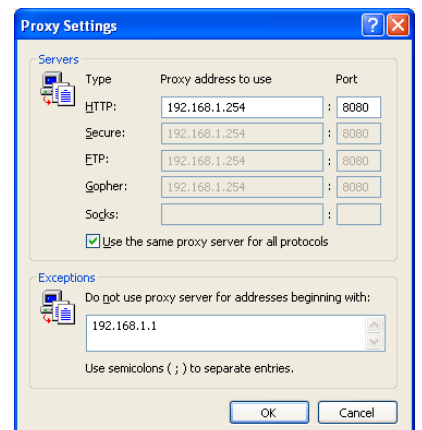

2-3 Setting the Java Execution Environment

When using Java Plug-in version 1.6.0_10 or later, make the following environment settings (not required for version 1.6.0_09 or earlier).

Note: The setting samples and screenshots used in this manual are those of Java Plug-in version 1.6.0_11.

2-3-1 Disabling the next-generation Java Plug-in

- (1) Open Java Control Panel by double-clicking Java in the Control Panel.
- (2) In the [Advanced] tab under the [Java Control Panel] screen, click the plus next to [Java Plug-in] to expand the list, and uncheck the checkbox next to [Enable the next-generation Java Plug-in (requires browser restart)].

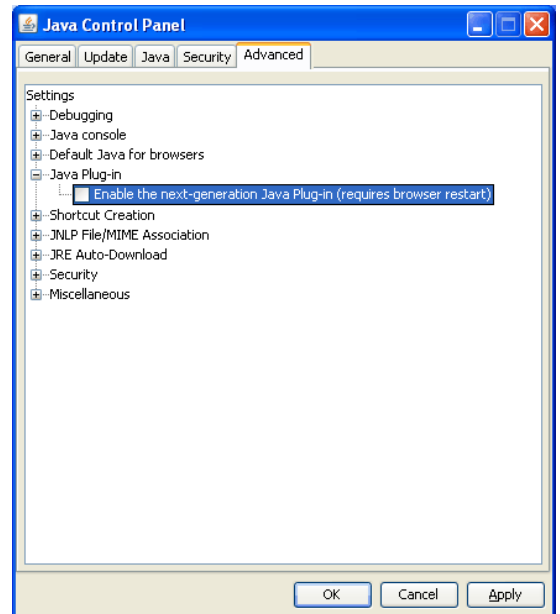

3 Performing Operations

Text below explains how to connect to the AG-150A and how to make various settings for the AG-150A.

Note: If the AG-150A is restarted due to a power interruption etc., wait until the screen on the AG-150A main unit displays the normal operation screen (it takes several minutes before the normal operation screen is displayed) before using a web browser to access the AG-150A. If access is attempted while the AG-150A is still starting up, the most recent data might not be displayed or communication errors could occur.

Note: Default IP address of AG-150A is "192.168.1.1". (Factory setting)

3-1 Logging in on the AG-150A

3-1-1 Logging in on the AG-150A

- Enter the web page address in the address field of the web browser as follows:

**http:// [IP address of the AG-150A]/g-50
/administrator.html**

Press the [Enter] key on the keyboard. A screen appears for login.

Note: For example, type "http://192.168.1.1/g-50/administrator.html" if the AG-150A IP address is [192.168.1.1].

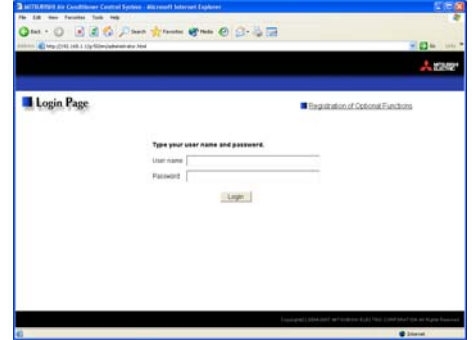

- To make connection easier for the next time, click the web browser menu item [Favorites], click [Add to Favorites], then add the address to the Favorites folder. Once this address is added to the Favorites folder, it is not necessary to input the address of (1). Simply select it from the Favorites folder and the AG-150A page will appear.

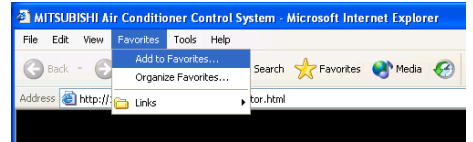

- Enter the user name and the password in the login screen, and click the [Login] button. A screen will appear in which various setting are made. An explanation on how to perform operations begins from the next page.

The table below shows the default user names and passwords for maintenance users and building managers as well as available functions.

User	Default user name	Default password	Available functions	
Maintenance user	initial	init	Initial settings	Date and Time, Basic System, Groups, Interlocked LOSSNAY, Blocks
			Functions 1	E-Mail, Peak cut, Measurement
			Functions 2	Set Temperature Range Limit, Night Mode Schedule, System-changeover
			Functions 3	Interlock control based on outside temperature, Setback control, Interlock control
			User Settings	User Settings
Building manager	administrator	admin	Out of the functions listed above, the items to which access rights have been given on the user settings screen are available.	

Note: The user name and the password for building manager are the same as those of the building manager of the Web for monitoring/operation.

Note: Maintenance users can make available to the administrator only the information necessary for normal operations (group name setting etc.)

Note: It is recommended to change the user name and password so users other than the manager are not permitted to change the settings.

Note: The Web page is displayed in the same language as the computer uses and it is also possible to display the Web page in other languages by entering the following Web page addresses.

- English :http://[The IP address of AG-150A]/g-50/en/administrator.html
- German :http://[The IP address of AG-150A]/g-50/de/administrator.html
- French :http://[The IP address of AG-150A]/g-50/fr/administrator.html
- Spanish :http://[The IP address of AG-150A]/g-50/es/administrator.html
- Italian :http://[The IP address of AG-150A]/g-50/it/administrator.html
- Russian :http://[The IP address of AG-150A]/g-50/ru/administrator.html
- Chinese :http://[The IP address of AG-150A]/g-50/zh/administrator.html
- Portuguese :http://[The IP address of AG-150A]/g-50/pt/administrator.html
- Japanese :http://[The IP address of AG-150A]/g-50/ja/administrator.html

3-1-2 Encrypting the communication data and login on the AG-150A

AG-150A can encrypt communication data using HTTPS (SSL).

When connecting the AG-150A to the LAN that can be accessed by the general public, it is recommended that the following settings be made so that the units are monitored and controlled on the encrypted Web page.

Note: Depending on the operating system or the version of Java, HTTPS encrypted messages may not be handled correctly. If this happens, use a HTTP connection to monitor and control the units as noted in the section above.

- (1) Go to [Tools]->[Internet Options]->[Advanced], and make the following settings.

Item	Checkbox setting
Use SSL 2.0	Uncheck the box.
Use SSL 3.0	Check the box.
Use TLS 1.0	Uncheck the box.
Do not save encrypted pages to disk	Check the box.

Note: Some of the settings may have different names depending on the Web browser version.

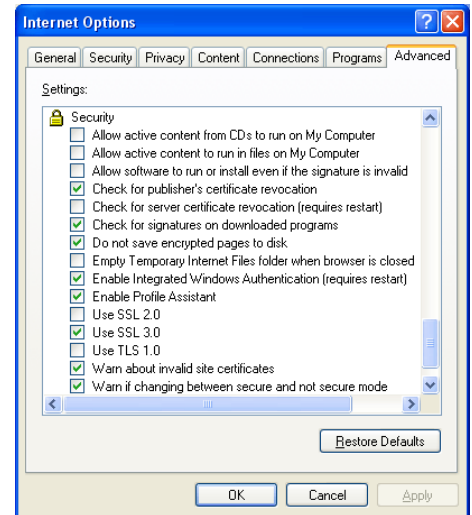

- (2) Click on [Java] in the Control Panel, and make the settings for the items under [Security] in the [Advanced] tab.

Item	Checkbox setting
Use SSL 2.0 compatible Client Hello format	Uncheck the box.
Use SSL 3.0	Check the box.
Use TLS 1.0	Uncheck the box.

Note: Some of the settings may have different names depending on the Java version.

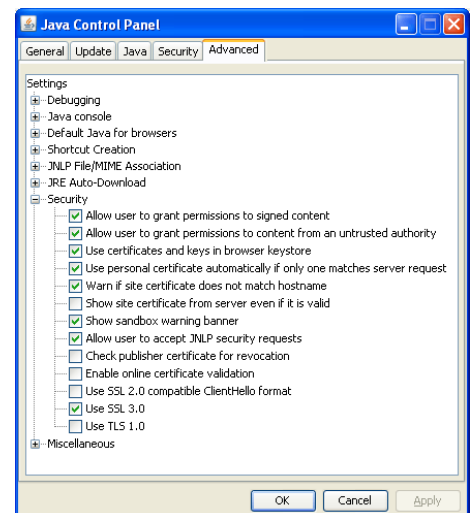

- (3) Prefix the Web address with [https], enter the address, and hit the [Enter] (Return) key on the keyboard.

**https://[IP Address of the AG-150A]/g-50
/administrator.html**

Note: For example, type "https://192.168.1.1/g-50/administrator.html" if the AG-150A IP address is [192.168.1.1].

If the security alert is disabled as described in the note in the following and the subsequent sections, encrypted data communication will begin, and the Login screen will appear. If the security alert has not been disabled, take the following procedures.



- (4) If the security alert has not been disabled, after entering the web address and hitting the Enter (Return) key, a security alert message will alert asking if you want to proceed . This is because the AG-150A uses the self-authentication system. Click [Yes] and proceed.

Note: Disable the security alert that appears every time the browser is opened, take the following two steps:

- 1) Register the security certificate and
- 2) Change the Web browser's option settings

To register the security certificate, click the [View Certificate] button on the security alert window to display the certificate, click on the [Install Certificate] button, and add the certificate to the Trusted Root Certification Authorities store. Just follow the prompts of the Import Wizard.

Go to [Tools]->[Internet Options]->[Advanced], and make the following settings for the Web browser.

Item	Checkbox setting
Warn about invalid site certificates	Uncheck the box.

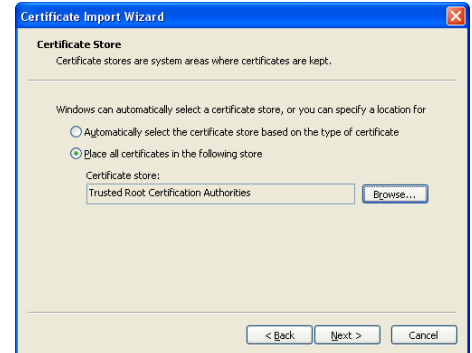

- (5) A Java security alert message will appear after you click [Yes] in step (4) above, click [Yes] again to proceed.

Note: To disable the security alert message that appears every time the browser is opened, check the check box next to [Always trust content from this publisher], and click [Yes]. The browser may need to be restarted to reflect the change.

Note: If the window shown on the right does not appear and connection fails, the certificate needs to be added to the Java certificate list. Click the [View Certificate] button on the screen in step (4) to display the certificate, click on the [Copy to File] on the [Details] page, and save the certificate in any desired location in the DER format. Open [Java] in the Control Panel, click on the [Certificates] button on the [Security] page to bring up the certificate registration screen. On the screen, select [Secure Site], click on the [Import] button, change the File of type to [All Files], and select the saved certificate. Now the certificate has been added to the Java certificate list.



- (6) If a connection is successfully made, the login window will appear. All communication with the AG-150A will be encrypted. The Web addresses for general users and in each language will have the web address in the previous section with "http" changed to "https".



4 Initial Settings

This chapter explains how to set the settings on the AG-150A's initial settings screen.

*Refer to Chapter 5 in the Instruction Book that came with the Centralized Controller AG-150A for how to set the settings after the initial power on.

4-1 Setting the Current Date and Time

Click [Initial Settings] in the menu, and [Date and Time] screen will appear on the screen. Enter the current date and time, and then press the [Save Settings] button to send the current date and time to AG-150A.

Note: If the user logs in as a building manager, the operations may be prohibited.

Note: If the system is connected to the TG-2000A, make all settings and changes from the TG-2000A so that the data in TG-2000A and AG-150A will match.

Note: When the time setting is made on this screen, the setting will be applied to all the units on M-NET system.

Note: The clock setting made on the screen below will be reflected on the clocks on other units that are connected to the M-NET line, on the Expansion Controllers (PAC-YG50ECA), and on the AG-150A controller whose "Time master setting" is set to Sub.

Note: When an Expansion Controller (PAC-YG50ECA), DIDO controller (PAC-YG66DCA), AI controller (PAC-YG63MCA), or PI controller (PAC-YG60MCA) is added to the system, set the clock on the added controller by making the clock setting on the clock setting screen.

Note: When an Expansion Controller (PAC-YG50ECA), DIDO controller (PAC-YG66DCA), AI Controller (PAC-YG63MCA), or PI Controller (PAC-YG60MCA) is newly connected, make the time setting of the connected controller on this screen.

Note: When connecting multiple AG-150A controllers by connecting an Expansion Controller to the system, set the "Time master" according to the instructions in section 4-2-3 "Time Master setting."

 **CAUTION** Date and clock settings on Expansion Controllers (PAC-YG50ECA), when connected, must be made with the Expansion Controller properly connected to ensure proper settings.

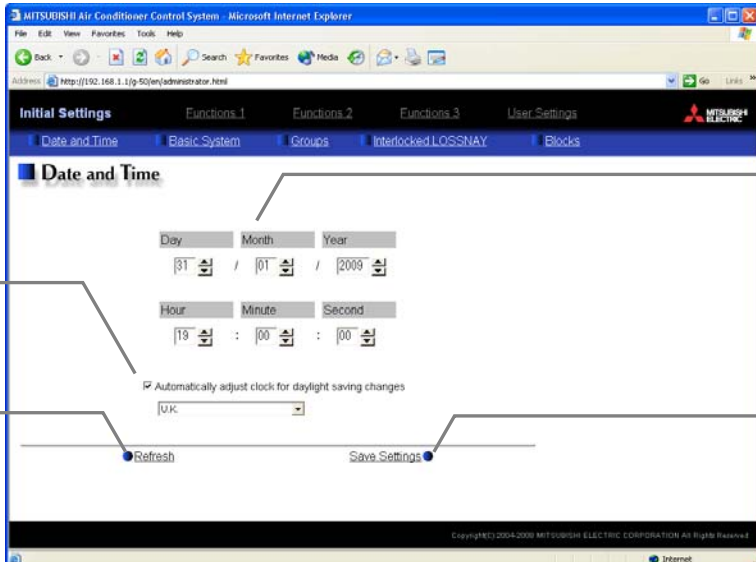

Current date/time
Enter the current date and time here.

Summer time setting
Click to set the daylight saving time.

Refresh
Acquires the current Date and Time from AG-150A.

Save settings
Click to set the current date and time.

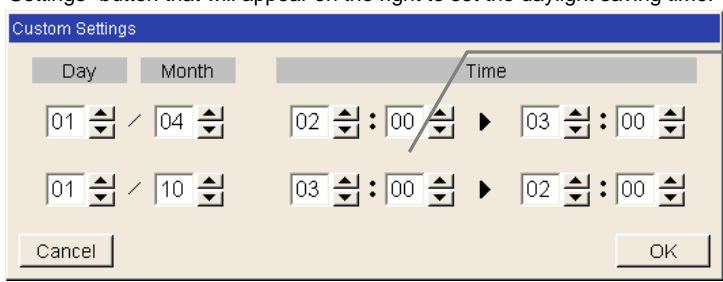
Item	Description
Current date/time	Enter the current date and time. For the date, use the format [day - month - year].
Save Settings	Click the [Date/Time Set] button to set the current date and time.
Refresh	Acquires the current Date and Time from AG-150A.
Summer time setting	<p>Click and tick the "Automatically adjust clock for daylight saving changes" box to adjust the daylight saving time automatically, and select the applicable country.</p> <p>Note: If the applicable country is not in the selection bar, select "Custom Settings". Click "Custom Settings" button that will appear on the right to set the daylight saving time.</p>  <p>Daylight saving date and time Set the daylight saving time.</p> <p style="text-align: center;">Custom Setting Screen</p>

4-2-2 Configuring the System Configuration Settings

In the System Configuration Settings menu, set the use or non-use of PAC-YG50ECA Expansion Controller, connection target, M-NET settings, and external input settings.

Note: When connecting multiple AG-150A controllers by connecting an Expansion Controller, all controllers must have the same system configurations.

4-2-2-1 Setting the Expansion Controller Connection Setting

In the M-NET Settings menu, set the use or non-use of PAC-YG50ECA Expansion Controller and connection target settings.



- (1) Select from “Do not use” or “Use” to set the use or non-use of an Expansion Controller.

Note: Before setting the Expansion Controller setting to “Use,” make sure that the Expansion Controller is connected to the LAN. The settings made without the Expansion Controller being connected may not be saved (M-NET settings, external input settings, group settings, LOSSNAY interlock settings etc., which are saved on the Expansion Controller side.)

- (2) If “Use” is selected for the Expansion Controller setting, an IP address input field will appear under “Access Point Settings.” Enter the IP address that is assigned to the Expansion Controller here.

When connecting two Expansion Controllers, first click [EC1]

and enter the IP address for the first Expansion Controller system, and then click [EC2] to enter the IP address for the second Expansion Controller system.

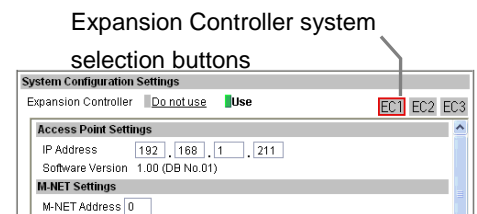

Note: Set the IP address for the Expansion Controller itself on the Expansion Controller unit.

- (3) After the Expansion Controller connection setting or the IP address of the Expansion Controller was changed, click the [Save] button and restart the AG-150A by following the messages on the screen. Make the M-NET settings and external input settings after the system has been restarted.

Note: After connecting the Expansion Controller, check that the database number (DB No.) on the controller itself and the data base number of the Expansion Controller match. If they do not, consult your dealer for software upgrade.

Note: To change the settings for the external input settings (or any other settings that are saved on the Expansion Controller side) after the M-NET settings have been made, restart the controller and change the settings with the Expansion Controller properly being connected to the system.

Note: To change the M-NET settings and external input settings in a system to which an Expansion Controller (PAC-YG50ECA) is connected, be sure to change the settings with the Expansion Controller properly connected to the system. These settings are stored on the Expansion Controller.

4-2-2-2 M-NET Setting

In M-NET Setting, set the AG-150A M-NET address, whether or not a K-Control unit is present and which machines send the prohibited controller command.

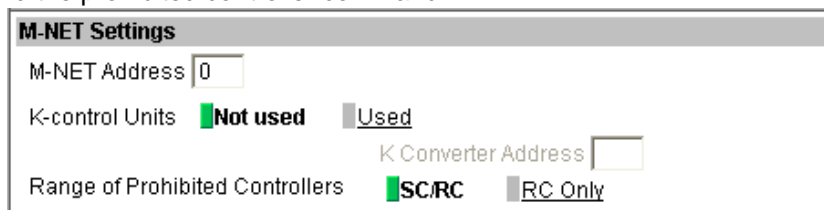

- (1) Enter the AG-150A M-NET address in the [M-NET Address] field. Normally you should enter [0].
- (2) When K-Control air conditioners are connected, click [Used] in the [K-Control Units] field and enter the M-NET address of K transmission converter in the [K Converter Address] field.
- (3) If prohibited controller (prohibiting local operation) has been set, this setting determines the scope of this setting's control, i.e. operation is prohibited for both the remote control and subordinate system controllers, or just for the remote control. Click [SC/RC] when you want prohibited controllers to include both subordinate system controllers and the remote control, or click [RC only] when you only want to prohibit operation on the remote control.

Note: Normally, you should select [SC/RC].

4-2-2-3 External Input Setting

In the External Input Setting menu, set the AG-150A external input function. By using external input functions, it is possible to stop and run multiple air conditioners connected to the AG-150A via the separately sold external I/O adapter for AG-150A (Model: PAC-YG10HA) and external power supply using level signals and pulse signals.

Note: If PAC-YG50ECA Expansion Controllers are connected, Expansion Controller system selection buttons will appear. Select the desired Expansion Controller, and make the settings for each system. Make the settings with the Expansion Controllers properly connected. Connect the external input signal wires to each controller's external input terminal.

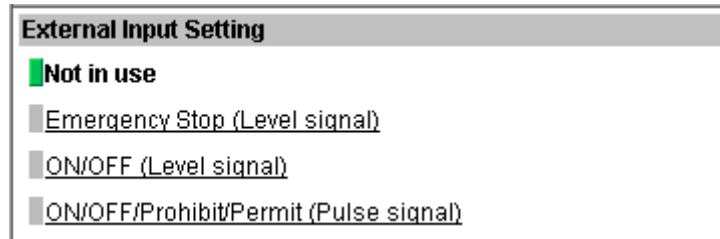

- (1) Select [Not in use] when not using the external input function.
- (2) Selecting [Emergency stop (Level signal)] makes it possible to stop multiple units by using a level signal. While this stop operation is being performed, operations such as running or stopping units are prohibited on the AG-150A unit or remote control.

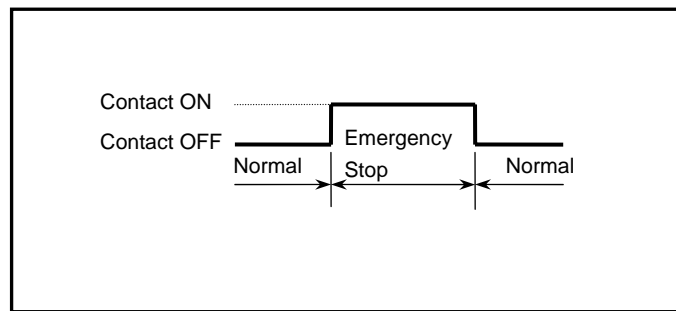
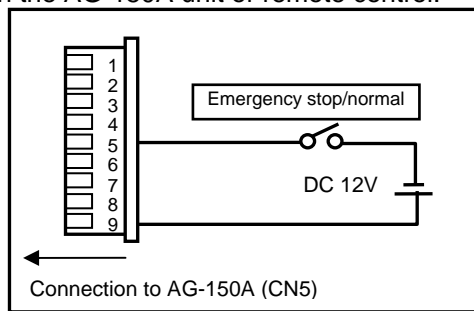

- (3) Selecting [ON/OFF (Level signal)] makes it possible to run or stop multiple units using a level signal. In this mode, all air conditioner units connected to the AG-150A will be run or stopped and run/stop operations will be prohibited on the AG-150A unit or remote control.

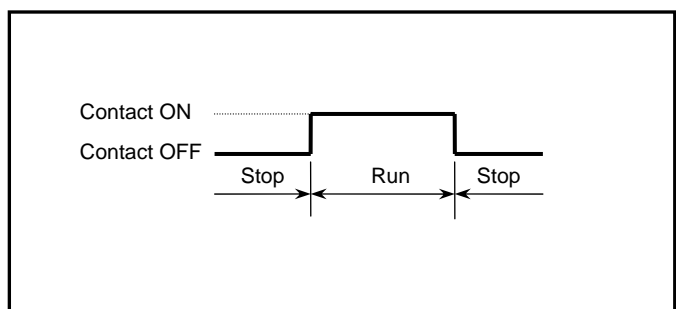
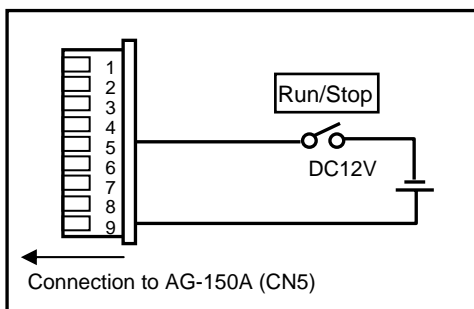

(4) Selecting [ON/OFF/Prohibit/Permit (Pulse signal)] makes it possible to use pulse signals to run multiple units, stop multiple units, prohibit local operation and permit local operation. In this mode, it is possible to freely operate the remote control except during the pulse signal input.

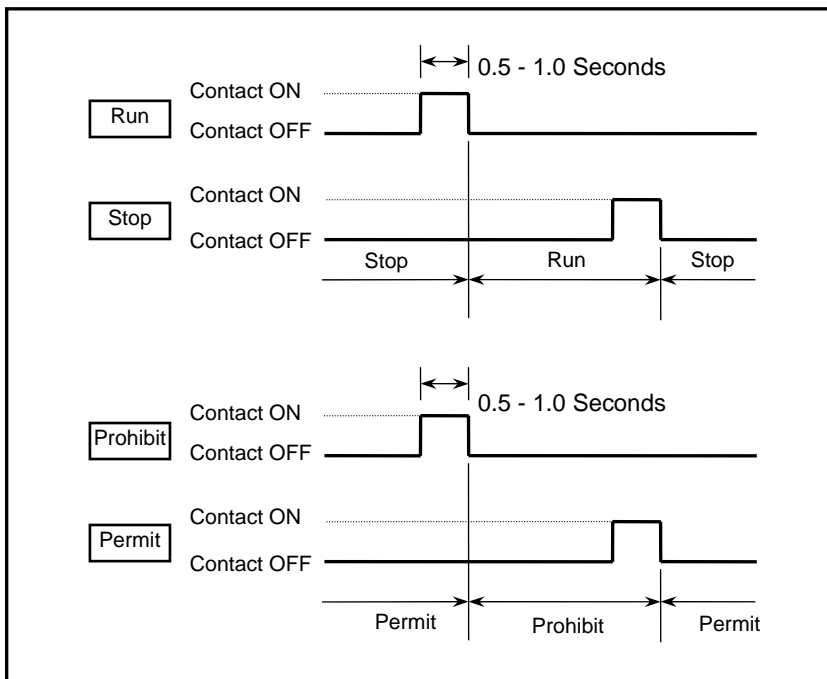
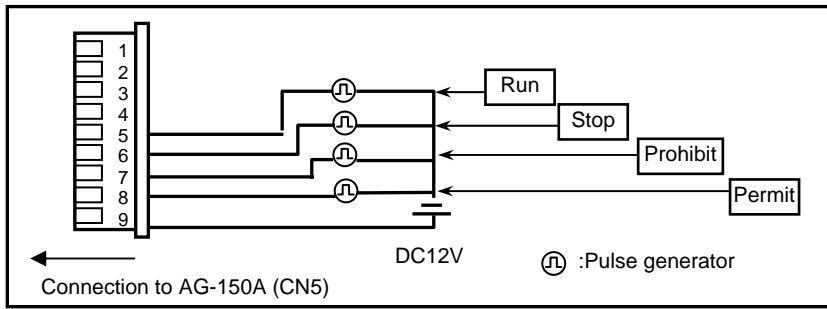

4-2-3 Time Master Setting

Set the clock on each AG-150A to Master or Sub by selecting either Master or Sub next to "Time Master."
 If an Expansion Controller (PAC-YG50ECA) is used to connect two AG-150A controllers, the unit whose clock is set to Sub will automatically synchronize its clock to the unit whose clock is set to Master.

Note: Of the AG-150A controllers that are connected to each Expansion Controller (PAC-YG50ECA), the "Time master" setting should be set to Master on only one AG-150A controller.



4-2-4 Network Setting

In Network Setting, set the AG-150A IP address, subnet mask and gateway address. If connecting to the AG-150A via a permanent LAN, consult with the network administrator before setting these addresses.

Network Settings				
IP Address	<input type="text" value="192"/>	<input type="text" value="168"/>	<input type="text" value="1"/>	<input type="text" value="1"/>
Subnet Mask	<input type="text" value="255"/>	<input type="text" value="255"/>	<input type="text" value="255"/>	<input type="text" value="0"/>
Gateway	<input type="text"/>	<input type="text"/>	<input type="text"/>	<input type="text"/>
MAC Address	080070334242			

4-2-4-1 Settings for when the AG-150A is connected to a dedicated LAN

(1) Enter the AG-150A IP address in the [IP Address] field. If the LAN wiring has been newly set up, allocate IP addresses to the AG-150A units in a sequential order starting with [192.168.1.1]. For example the first AG-150A unit will receive an IP address of [192.168.1.1], the second AG-150A unit will receive an IP address of [192.168.1.2] and so on.

The Web Monitor PC that monitors and sets AG-150A will also require network addresses consistent with the rest of the LAN.

Note: When using a AG-150A dedicated LAN, it is recommended to set the IP address as follows.

AG-150A: Between [192.168.1.1] and [192.168.1.40] Web Monitor PC: Between [192.168.1.101] and [192.168.1.150]

[Example of IP address setting]

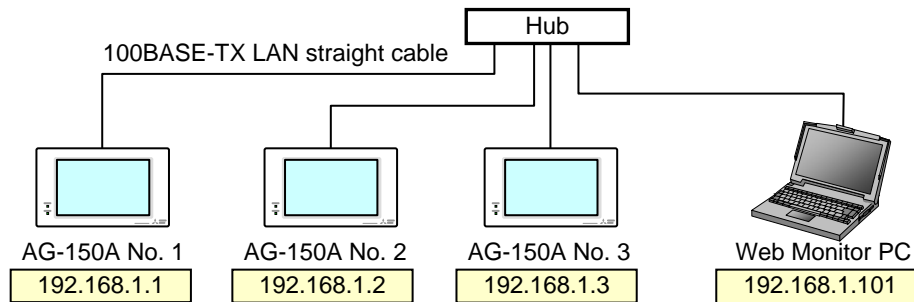

Note: Some hubs have a dedicated port for connection with another hub. Connect the AG-150A and Web Monitor PC to the normal ports.

(2) Enter the AG-150A subnet mask in the [Subnet Mask] field. Normally, you should enter [255.255.255.0].

(3) When monitoring remotely or sending error mail via a dial-up router, enter the router IP address in the [Gateway] field.

Leave the gateway address blank when not connecting via a dial-up router.

[Example of a Remote Monitoring System]

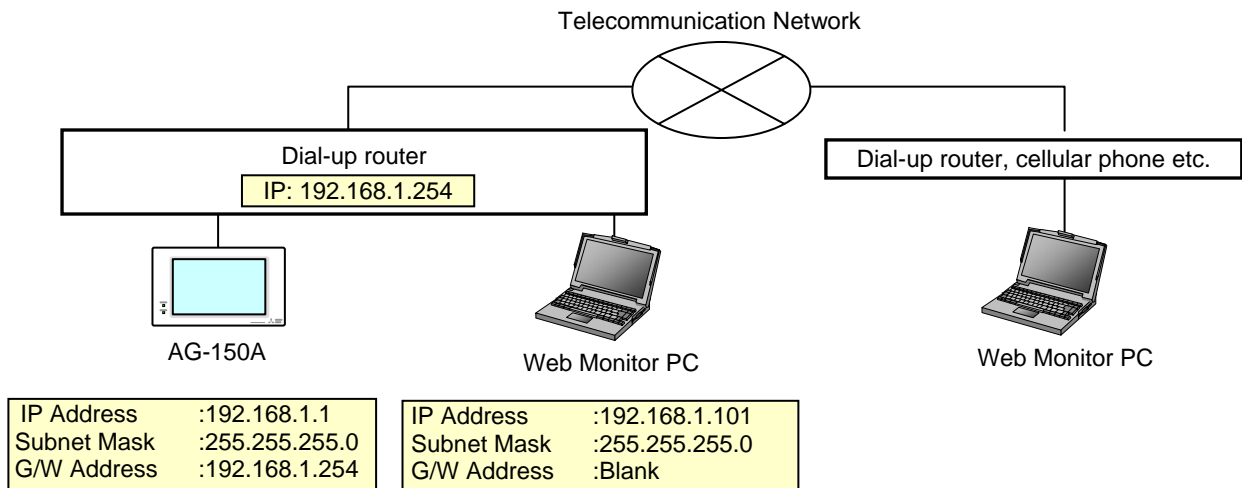

Note: It is recommended to set the dial-up router IP address to [192.168.1.254]. Refer to the dial-up router instruction manual for details of how to set the IP address.

Note: It is necessary to connect a modem (analog type or ISDN type) between the dial-up router and telephone line when using a dial-up router that does not have a built-in modem.

4-2-4-2 Settings for when the AG-150A is connected to an existing LAN

When connecting the AG-150A to an existing LAN, consult with the network administrator who is responsible for the LAN before setting the IP address, subnet mask, or gateway address.

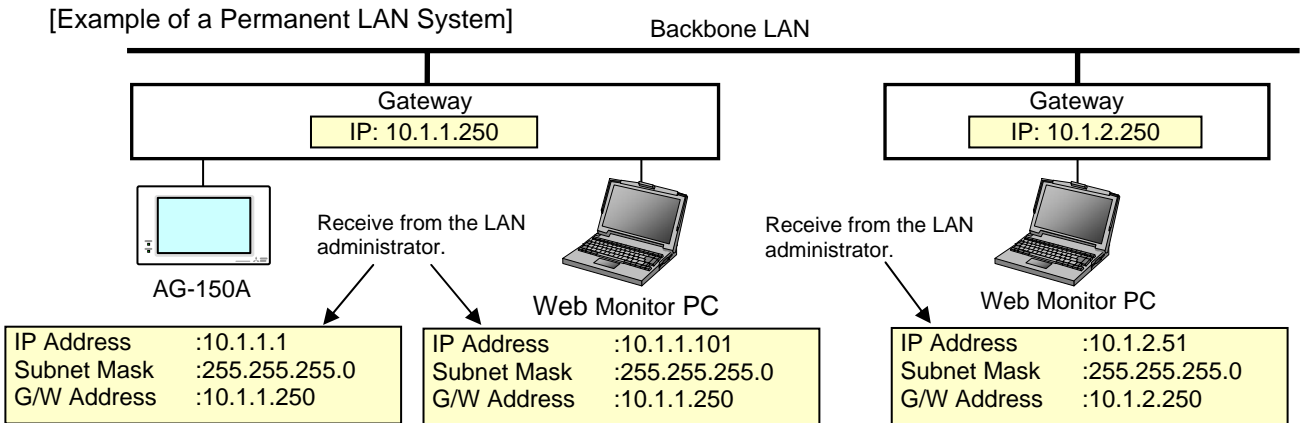

4-2-5 Setting the Display Format

Set the items related to the screen display in the [Display Format] field.

Display Format	
Unit of Temperature	<input checked="" type="checkbox"/> °C <input type="checkbox"/> °F
Date Format	<input checked="" type="checkbox"/> 31/12/2008 <input type="checkbox"/> 12/31/2008 <input type="checkbox"/> 2008/12/31
Time Format	<input type="checkbox"/> 06:00 PM <input checked="" type="checkbox"/> 18:00
Group Names on Overview Monitor	<input checked="" type="checkbox"/> ON <input type="checkbox"/> OFF
Filter Sign Display	<input checked="" type="checkbox"/> ON <input type="checkbox"/> OFF

- (1) In the [Unit of Temperature] section, select between [°C] and [°F] as the unit of temperature.
- (2) In the [Date Format] section, select the display order of year/month/day. The date will be displayed in the selected order on the Web screen or on the mail screen.
Note: Set the format of the date to be displayed on the LCD on the LCD Setting screen.
- (3) In the [Time Format] section, select the display of time format. The time will be displayed in the selected format on the Web screen.
Note: Set the format of the time to be displayed on the LCD on the LCD Setting screen.
- (4) In the [Group Names on Overview Monitor] section, select [ON] to display the group name under the icon on the [Monitor / Operation (Overview)] screen and select [OFF] not to.
Note: Up to 8 letters are displayed under the icon. To display all letters, move the cursor to the icon.

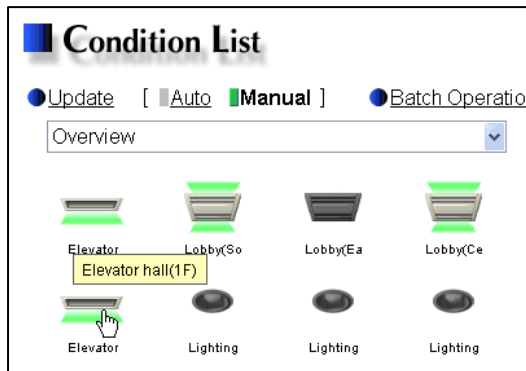

With the display of group names

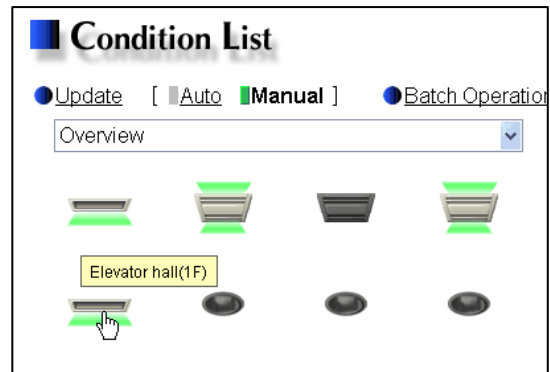

Without the display of group names

(5) In the [Filter Sign Display] section, select whether to display the filter sign. Select [ON] to display the filter sign and [OFF] not to.

When the filter sign display is set to "OFF," the filter sign on neither the LCD of the AG-150A nor the monitor screen on the Web browser will appear, even when the indoor unit detects a filter sign.

If the filter is regularly cleaned and the filter sign display is unnecessary, set it to [OFF].

4-3 Group Setting

Display the page needed to register the group of air conditioners or general equipment to be connected to the AG-150A and to set the group name by clicking [Initial Settings]-[Groups]. On this page, you perform the basic setting such as the AG-150A unit name, network setting and M-NET setting. Click [Set to AG-150A] to send setting data to the AG-150A.

Note: If PAC-YG50ECA Expansion Controllers are connected, Expansion Controller system selection buttons will appear. Select the desired Expansion Controller (EC1, EC2, or EC3), and make the settings for each system.

Note: If the user logs in as a building manager, some of the operations may be prohibited.

Note: If the system is connected to the TG-2000A, make all settings and changes from the TG-2000A so that the data in TG-2000A and AG-150A will match.

Note: A contact on the general interface device is regarded as one unit. The number of units that can be connected to AG-150A is up to 50.

Note: Air-conditioners and general equipment cannot be in the same group.

Note: Remote controllers or system controllers cannot be connected to general equipment.

Note: When connecting multiple AG-150A controllers by connecting an Expansion Controller, all controllers must have the same control group settings.



CAUTION

Control group settings on Expansion Controllers (PAC-YG50ECA), when connected, must be made with the Expansion Controller properly connected to ensure proper settings.

Group No.
Group numbers will be displayed here.

Group name
The group names are entered here.

Refresh
Read setting data from AG-150A.

Air Conditioner or general equipment or hot water supply Registration
Register the air conditioner or general equipment or hot water supply to be connected here. Click to bring up the registration screen.

Expansion Controller system selection buttons
Click to select the system to be set.

System Controller Registration
Register the system controllers to be connected here. Click to bring up the registration screen.

Remote Controller Registration
Register the remote controllers to be connected here. Click to bring up the registration screen.

Save Settings
Send setting data to AG-150A.

4-3-1 Setting the Group Name

(1) In the [Group Name for Web] field on the screen, register the group name to be displayed on the Web screen, using a name consisting of no more than 20 characters.

Note: The following characters cannot be used in the group name: < > & " ' "

(2) Next, in the [Group name for LCD of the AG-150A] field, enter the group name to be displayed on the LCD of the AG-150A consisting of no more than 10 numbers, upper case letters, hyphen, or space combined.

4-3-2 Registering air conditioner or hot water supply units in the group

(1) To register air-conditioners, clicking the [Air Conditioner or general equipment or hot water supply Registration] field next to each group in the [Groups] screen will bring up the [Select Unit Addresses] screen. Click on the numbers corresponding to the units to be registered. All selected units will be shown with a yellow-green background.

To cancel the selection, click on them again. Deselected items will be shown with a gray background.

Note: A maximum of 16 air conditioner units can be registered in one group.

Note: To change the registered units to air-conditioners in the group in which general equipment is registered, disconnect the general equipment first.

(2) To change the icon, click the right or left arrow.

- (3) To register remote controllers in a group, click on the [Remote Controller Registration] field to display the [Select Unit Addresses] screen, and click on the numbers corresponding to the units to be registered. The ones that are selected will be shown with a yellow-green background. To cancel the selection, click on them again. Deselected items will be shown with a gray background.

Note: A maximum of 2 remote controls can be registered in one group.

Note: MA remote controls do not need to be registered to a group.

- (4) To register system remote controllers in a group, click on the [System Controller Registration] field to display the [Select Unit Addresses] screen, and click on the numbers corresponding to the units to be registered. The ones that are selected will be shown with a yellow-green background. To cancel the selection, click on them again. Deselected items will be shown with a gray background.

Note: The combined number of system controllers and remote controls cannot exceed four.

Note: K-transmission converters do not need to be registered.

4-3-3 Registering general equipment in the group

- (1) To register general equipment in a group, click on the [Air Conditioner or general equipment or hot water supply Registration] field to display the [Select Unit Addresses] screen, and select the [General Equipment (via PAC-YG66DCA)].

Click the device No. of the general interface device (PAC-YG66DCA) that is connected to the general equipment to be registered. The selected No. will be displayed with a red frame (selected state), and select the contact No. to which the general equipment is connected.

To disconnect the general equipment, select the interface device No., and click the contact No. that has been selected. The No. will be displayed in gray (unselected state).

Note: A maximum of 16 general equipment can be registered in one group.

Note: To change the registered units to general equipment in the group in which air-conditioners are registered, disconnect the air-conditioners first.

- (2) To change the icon, click the right or left arrow.

- (3) In the [Allow Operation] section, select whether to enable or disable the ON/OFF operation on the Web browser or on the TG-2000A operation screen. Select [In batch and on individual group] to enable only when the collective operation is performed. Select [On individual group] to enable in each group. Select [No operation (Monitor only)] to disable.

- (4) In the [Monitor] section, select whether to display I/P to or from the general equipment on the monitor screen.

4-4 Interlocked Setting

To interlock the operation of LOSSNAY with the run/stop status of the indoor units, click on [Initial Settings]-[Interlocked LOSSNAY] in the menu to bring up the Interlocked LOSSNAY screen, and enter the interlock conditions. Click [Save Settings] to send setting data to the AG-150A.

Note: If PAC-YG50ECA Expansion Controllers are connected, Expansion Controller system selection buttons will appear. Select the desired Expansion Controller (EC1, EC2, or EC3), and make the settings for each system. Make the settings with the Expansion Controllers properly connected.

Note: If the user logs in as a building manager, the operations may be prohibited.

Note: If the system is connected to the TG-2000A, make all settings and changes from the TG-2000A so that the data in TG-2000A and AG-150A will match.

Note: When connecting multiple AG-150A controllers by connecting an Expansion Controller, all controllers must have the same LOSSNAY unit interlocking conditions settings.



CAUTION LOSSNAY unit interlocking conditions settings on Expansion Controllers (PAC-YG50ECA), when connected, must be made with the Expansion Controller properly connected to ensure proper settings.

Expansion Controller system selection buttons
Click to select the system to be set.

Interlocked LOSSNAY Registration
Register the interlocked ventilation equipment here. Click to bring up the registration screen.

Refresh
Read setting data from AG-150A.

Interlocked Indoor Units Registration
Register the indoor units to which LOSSNAY units are interlocked here. Click to bring up the registration screen.

Save Settings
Send setting data to AG-150A.

- (1) Click in the Interlocked LOSSNAY registration field to display the [Select Unit Addresses] screen, and click on the numbers corresponding to the units to be registered. The ones that are selected will be shown with a yellow-green background. To cancel the selection, click on them again. Deselected items will be shown with a gray background.

- (2) Click on the Interlocked Indoor Unit Registration field to display the [Select Unit Address] for the indoor units, and click on the numbers corresponding to the units to be registered. The ones that are selected will be shown with a yellow-green background. To cancel the selection, click on them again. Deselected items will be shown with a gray background.

Note: A maximum of 16 indoor units can be registered to operate with one ventilator.

4-5 Block Setting

By performing block settings, multiples of air conditioner groups can be collectively monitored or operated from the Web or TG-2000A. It also enables energy-save/peak cut controls. Bring up the Block Setting screen by clicking [Initial Settings]-[Blocks] in the menu, and register the groups in the block to utilize these features. Click [Save Settings] to send setting data to the AG-150A.

Note: If the user logs in as a building manager, some of the operations may be prohibited.

Note: If the system is connected to the TG-2000A, make all settings and changes from the TG-2000A so that the data in TG-2000A and AG-150A will match.

4-5-1 Registering a block name

In the [Block Name] field on the screen, register the block name to be displayed on the Web screen, using a name consisting of no more than 20 characters

Note: The following characters cannot be used in the group name: < > & " "

4-5-2 Registering a group in a block

Click on the Group Registration field to display [Select Groups], and click on the numbers corresponding to the groups to be registered. The ones that are selected will be shown with a yellow-green background. (Putting a cursor on the group number will display the group name.) To cancel the selection, click on them again. Deselected items will be shown with a gray background.

Note: If PAC-YG50ECA Expansion Controllers are connected, Expansion Controller system selection buttons will appear. Select the desired Expansion Controller (EC1, EC2, or EC3), and make the settings for each system. Make the settings with the Expansion Controllers properly connected.

Expansion Controller system selection buttons

5 Functions 1

5-1 Error mail reports/E-mail communication

Click on [Functions 1] – [E-Mail] in the menu to open the [E-mail] window and make necessary settings to perform remote monitoring via mail, using error mail report or the maintenance tool.

Click [Save Settings] to send setting data to the AG-150A.

Note: The use of the error mail report function requires a separate license registration.

Confirm on the license registration screen (Ch8) that the license registration has been completed.

Note: If the user logs in as a building manager, the operations may be prohibited.

Mail Server Information
Set the mail server/DNS server information here.

Mail Communication Setting
Set the address of the mail recipients here.

Refresh
Read setting data from AG-150A.

E-Mail settings of AG-150A
The E-mail settings of AG-150A are set here.

Error Mail Settings
Set the error mail destination here.

Save Settings
Send setting data to AG-150A.

5-1-1 Entering the E-Mail Information for the AG-150A

Enter the E-mail information provided by either the ISP or the LAN administrator.

Note: When sending E-mail via an ISP, a user contract with the ISP is required.

E-Mail Settings of AG-150A

E-Mail Address

User ID

Password

Interval of checking incoming mails minute(s)

Make necessary settings based on the functions that are to be used, using the table below as a reference.

Table 5-1 Items that Require Settings to Be Made (E-Mail Settings of AG-150A)

Items	Functions	Error Mail Report		Mail Communication	
		No SMTP Authentication	Uses SMTP Authentication	No SMTP Authentication	Uses SMTP Authentication
Mail Address		√	√	√	√
User ID			√	√	√
Password			√	√	√
Interval of checking incoming mails				√	√

5-1-2 Setting the Mail Server Information

Enter the mail server information provided by either the ISP or the LAN administrator.

Either the IP address or the host name (server name) can be entered in the mail server field.

Make necessary settings depending on the functions to be used, using the table below as a reference.

Table 5-2 Items that Require Settings to Be Made (Mail Server Information)

Items	Functions	Error Mail Report		Mail Communication	
		No SMTP Authentication	Uses SMTP Authentication	No SMTP Authentication	Uses SMTP Authentication
Outgoing Mail Server (SMTP)		√ IP Address or Host Name	√ Host Name	√ IP Address or Host Name	√ Host Name
SMTP Authentication			√		√
Incoming Mail Server (POP3)				√ IP Address or Host Name	√ IP Address or Host Name
DNS Server (Primary)		(V) ^{*1}	√	(V) ^{*1}	√
DNS Server (Secondary)		(V) ^{*1}	√	(V) ^{*1}	√

*1: Not necessary if the IP address is used as the mail server address.

5-1-3 Setting the Error Mail Destinations

- Enter the title of the error mail that will be sent from AG-150A in the [Mail Title] field. The title may contain a maximum of 40 characters.

Note: The following characters cannot be used in the mail title:

< > & " '

- Choose the error type out of the following: [Unit Error], [Preliminary Unit Error], [Communication Error], [General Equipment] and [User Setting 1] through [User Setting 6]. Then enter the mail address of the recipient of the error mail.

- To send error messages only upon occurrences of certain errors, click the User Setting button that appear when "User Setting 1" through "User Setting 6" are selected, and register the error codes to be reported in the user settings. A maximum of 20 error codes can be set for each user setting. In addition to specific error codes such as [1302] or [6607], codes such as [10**] or [12**] can also be used. If [10**] is set, for example, error mail will be sent upon an occurrence of any type of errors between [1000] and [1099]. If error codes are set on this screen, confirm that the address of the recipient is registered.

(4) To e-mail an error when an error occurs on general equipment connected to PLC for general equipment, click the PLC Connection button, which appears at the time of selection of "General Equipment", to set the IP address of PLC for general equipment. The row number of the set IP address will be in an error mail as a PLC number. (Eg. When an error occurs on the No.20 PLC for general equipment that is in the second row, "PLC2-20" will be displayed on the error source

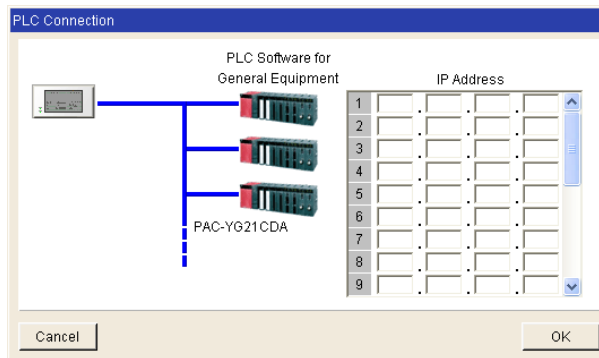

Note: TG-2000A is necessary to monitor the status of general equipment.

5-1-4 Setting the Addresses of the Recipient

To monitor and operate the unit with the maintenance tool via mail from a remote location, enter the mail address of the receiver in the [Mail Communication Setting].

A maximum of 10 addresses can be registered.

E-mail communication is possible only with the recipients whose addresses are registered on this screen.

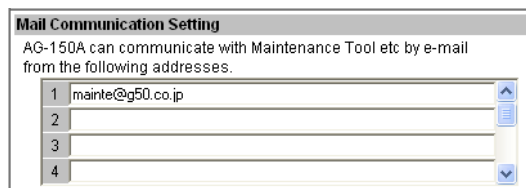

5-1-5 Mail format

Error mails are sent in the format shown below.

From:Mitsubishi Building(000001)
 Date:11/09/2005 16:32:12
 Error unit:065
 Error code:1302
 Status:Occurrence

Item	Format	Remarks
Mail title	Set title	Refer to 5-1-3 (1) for the setting of mail title.
From	AG-150A unit name and unit ID	Refer to 4-2-1 for the setting of AG-150A unit name and unit ID.
Date	dd/MM/yyyy hh:mm:ss	Date of error Note: The date format set in section 4-2-4 will be applied.
Error unit	<p>When an error occurs on air conditioners and general equipment</p> <ul style="list-style-type: none"> - M-NET address of the error source Note: If an Expansion Controller is connected, the unit in error will appear in the [Expansion Controller No. (1-3)]-[M-NET address] format. <p>When an error occurs on general equipment that is connected to PLC for general equipment</p> <ul style="list-style-type: none"> - PLC number (1 to 20) + connection number of general equipment (1 to 32) <p>When a communication error occurs on PLC for general equipment</p> <ul style="list-style-type: none"> - PLC number (1 to 20) 	<p>PLC number indicates the row number on the setting screen shown in 5-1-3 (4).</p> <p>Note: When an error occurs on the general equipment that is connected via DIDO controller, M-NET address of the DIDO controller will be sent. (which means an error occurs on one of the general equipment that is connected to the DIDO controller)</p>
Error code	4-digit error	<p>When an error occurs on air conditioners</p> <p>Refer to the service manual for each unit.</p> <p>When an error occurs on general equipment</p> <p>0091:General equipment error</p> <p>When a communication error occurs on PLC for general equipment</p> <p>0003:LAN communication error to PLC</p> <p>0007:PLC stop</p>
Status	"Occurrence" or "Recovery"	Error status

5-2 Energy-Save Control and Peak Cut Control

Click on [Functions 1] – [Peak Cut] in the menu to bring up the peak cut control screen, and make necessary peak cut settings to use the energy-save or peak cut control function.

Click [Save Settings] to send setting data to the AG-150A.

Note: Run the test run mode, and check that the equipment related to peak cut is connected properly to perform peak cut control. (It is possible to perform control compulsorily by changing the control level.)

Note: The use of energy-save/peak cut control functions requires a separate license registration. Confirm on the license registration screen (Ch8) that the license registration has been completed.

Note: If the user logs in as a building manager, some of the operations may be prohibited.

Note: When connecting AG-150A controllers by connecting an Expansion Controller to the system, energy-save and peak-cut settings should be made only on one of the AG-150A controllers.

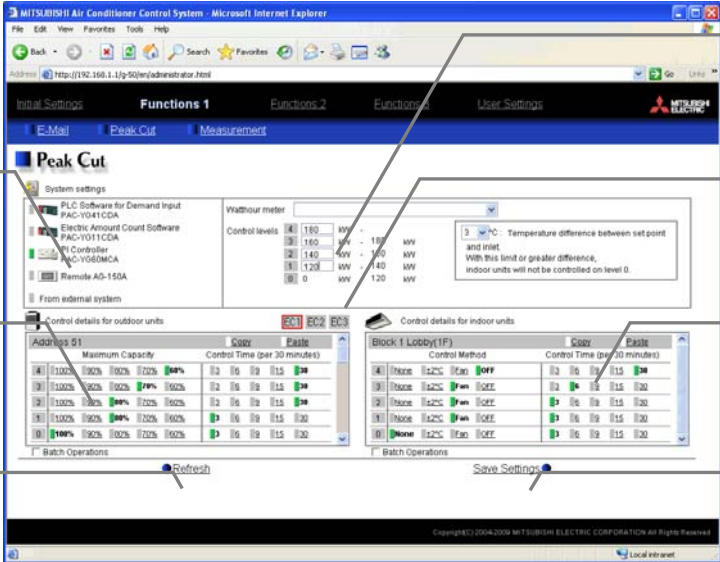

Peak cut method
Select the peak cut method.

Outdoor unit control method
Set the outdoor unit control method.

Refresh
Read setting data from AG-150A and PLC.

Setting details
Set the details of the selected method.

Expansion Controller system selection buttons
Click to select the system to be set.

Indoor unit control method
Set the indoor unit control method.

Save Settings
Send setting data to AG-150A and PLC.

To enable peak cut, register the "Energy Saving (Peak Cut)" license to all AG-150A, and set the peak cut method and the indoor/outdoor units control methods. When the license is registered, the control can be performed in 5 degrees (Level 0-4).

To enable energy saving control at the constant rate, register the "Energy Saving" license to all AG-150A, and set the level to "0" in [Indoor/Outdoor unit control method] section.

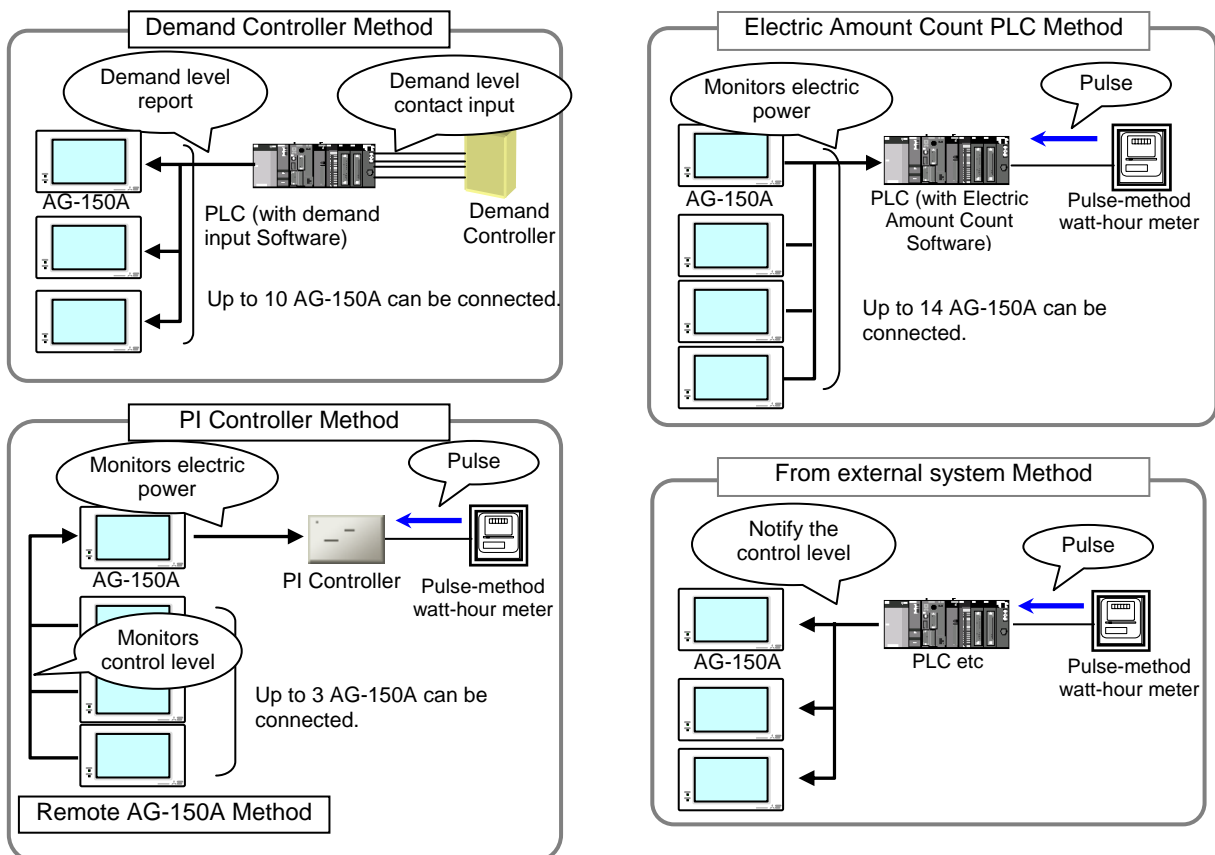

5-2-1 When Demand Controller Method is used

The screenshot shows the configuration interface for the Demand Controller Method. On the left, there are four software options: 'PLC Software for Demand Input PAC-YG41CDA' (selected), 'Electric Amount Count Software PAC-YG11CDA', 'PI Controller PAC-YG60MCA', and 'Remote AG-150A'. Below these is a button labeled 'Initialize'. The center section is for 'Controlled AG-150A' and includes an 'IP Address' field set to 192.168.1.171 and a table for registering 10 addresses. The table has columns for unit number (1-6), IP address (192, 168, 1, and a blank), and a dropdown menu. The right section shows a temperature difference limit set to 3 °C, with a note: 'With this limit or greater difference, indoor units will not be controlled on level 0.'

- (1) To use Demand Controller Method, before using the PLC Software for demand input or Electric Amount Count Software, click on the PLC initialize button once to initialize the internal memory.

Note: Do not initialize the memory after the operation has begun, for it will clear all operation data.

- (2) Enter the IP address for the PLC software for demand input.
- (3) Enter the IP address of the AG-150A to which the demand levels are reported. A maximum of 10 addresses can be registered.
- (4) When the energy-save level is set to 0 (It is always set to level 0 in an energy-save control method), energy-save control will not be performed for the indoor units that show a greater difference between the set temperature and indoor temperature than the value set in the window on the right. Make the setting when some type of energy-saving control is effective at energy-save level 0 and the level of comfort is high on priority list. (Choose between 3 to 9)

5-2-2 When Electric Amount Count PLC Method (Amount Count Software) is used

The screenshot shows the configuration interface for the Electric Amount Count PLC Method. On the left, there are four software options: 'PLC Software for Demand Input PAC-YG41CDA', 'Electric Amount Count Software PAC-YG11CDA' (selected), 'PI Controller PAC-YG60MCA', and 'Remote AG-150A'. Below these is a button labeled 'Initialize'. The center section includes an 'IP Address' field set to 192.168.1.151, a 'DI Board' dropdown set to 1, and a 'Pulse Unit' field set to 0.1 kWh / pulse. Below these is a table for 'Control levels' with columns for level number (4, 3, 2, 1, 0), a value, and a unit (kW). The table shows values of 180, 180, 140, 120, and 0 kW respectively. The right section shows a temperature difference limit set to 3 °C, with a note: 'With this limit or greater difference, indoor units will not be controlled on level 0.'

- (1) To use Electric Amount Count PLC Method, before using the PLC Software for demand input or Electric Amount Count Software, click on the PLC initialize button once to initialize the internal memory.

Note: Do not initialize the memory after the operation has begun, for it will clear all operation data.

- (2) Enter the IP address of the electric amount count software.
- (3) Select the terminal number of the DI board to which the watt-hour meter is connected. If it is connected to terminal 2 on DI board 1, select 1-2.

Note: Select an input board from either 1 or 2, and select an input terminal from 0 to F. Choose the terminal to which the watt-hour meter is connected that is used for peak cut.

- (4) Enter the unit of the pulse that the watt-hour meter outputs.

Note: Set the value per pulse according to the measurement meter to be used. To check that the setting is correctly made, first check both the values measured by the measurement meter and by the measurement controller, and after a certain time, check that the both values have increased at equal increments. (The value measured by the measurement controller can be checked on the browser for the administrator.)

- (5) Determine the range of electricity use for each control level (demand level), taking into consideration such factors as delayed control of the air conditioner. Enter the value that is 10 to 15% below the maximum demand value (average electric energy value in 30 minutes) in the blank next to Level 4. Decrease the value by about 10 % for each level below. (The figure on the right shows the system with the maximum electric energy at 200 kW.)

Note: The best set point depends on the system configuration of the electric equipment and the indoor environment in each building. Choose appropriate set points accordingly.

Note: The amount of electricity that is actually used may exceed the demand value due to such unexpected incidents as controller problems or broken transmission lines. Mitsubishi will not be responsible for such incidents.

- (6) When the energy-save level is set to 0 (It is always set to level 0 in an energy-save control method), energy-save control will not be performed for the indoor units that show a greater difference between the set temperature and indoor temperature than the value set in the window on the right.

Make the setting when some type of energy-saving control is effective at energy-save level 0 and the level of comfort is high on priority list. (Choose between 3 to 9)

5-2-3 When PI Controller Method is used

<input type="checkbox"/> PLC Software for Demand Input PAC-YG41CDA <input type="checkbox"/> Electric Amount Count Software PAC-YG11CDA <input checked="" type="checkbox"/> PI Controller PAC-YG60MCA <input type="checkbox"/> Remote AG-150A <input type="checkbox"/> From external system	Watthour meter: Address50-4 Whm (Peakcut) Control levels: <table border="1"> <tr><td>4</td><td>180</td><td>kW</td><td>-</td><td></td></tr> <tr><td>3</td><td>160</td><td>kW</td><td>-</td><td>180 kW</td></tr> <tr><td>2</td><td>140</td><td>kW</td><td>-</td><td>160 kW</td></tr> <tr><td>1</td><td>120</td><td>kW</td><td>-</td><td>140 kW</td></tr> <tr><td>0</td><td>0</td><td>kW</td><td>-</td><td>120 kW</td></tr> </table>	4	180	kW	-		3	160	kW	-	180 kW	2	140	kW	-	160 kW	1	120	kW	-	140 kW	0	0	kW	-	120 kW	<input type="text" value="3"/> °C : Temperature difference between set point and inlet. With this limit or greater difference, indoor units will not be controlled on level 0.
4	180	kW	-																								
3	160	kW	-	180 kW																							
2	140	kW	-	160 kW																							
1	120	kW	-	140 kW																							
0	0	kW	-	120 kW																							

- (1) Select the PI controller to which the watt-hour meter used for peak cut control is connected.

Note: Only the watt-hour meters that have been registered on the Measurement screen can be selected.

- (2) Determine the range of electricity use for each control level (demand level), taking into consideration such factors as delayed control of the air conditioner. Enter the value that is 10 to 15% below the maximum demand value (average electric energy value in 30 minutes) in the blank next to Level 4. Decrease the value by about 10 % for each level below. (The figure on the right shows the system with the maximum electric energy at 200 kW.)

Note: The best set point depends on the system configuration of the electric equipment and the indoor environment in each building. Choose appropriate set points accordingly.

Note: The amount of electricity that is actually used may exceed the demand value due to such unexpected incidents as controller problems or broken transmission lines. Mitsubishi will not be responsible for such incidents.

- (3) When the energy-save level is set to 0 (It is always set to level 0 in an energy-save control method), energy-save control will not be performed for the indoor units that show a greater difference between the set temperature and indoor temperature than the value set in the window on the right. Make the setting when some type of energy-saving control is effective at energy-save level 0 and the level of comfort is high on priority list. (Choose between 3 to 9)

5-2-4 When Remote AG-150A Method is used

<input type="checkbox"/> PLC Software for Demand Input PAC-YG41CDA <input type="checkbox"/> Electric Amount Count Software PAC-YG11CDA <input type="checkbox"/> PI Controller PAC-YG60MCA <input checked="" type="checkbox"/> Remote AG-150A <input type="checkbox"/> From external system	IP Address: <input type="text" value="192"/> . <input type="text" value="168"/> . <input type="text" value="1"/> . <input type="text" value="1"/>	<input type="text" value="3"/> °C : Temperature difference between set point and inlet. With this limit or greater difference, indoor units will not be controlled on level 0.
---	---	---





- (1) Enter the IP address of the AG-150A to which the PI controller (with the connection to the watt-hour meter used for peak cut control) is connected.

Note: As the control level of AG-150A to which the watt-hour meter is connected is monitored every minute, the control level changes after a delay of approx. one minute. Take this delay into consideration, and set the control level without exceeding the range of peak cut electricity.

Note: Only up to three AG-150A can be connected to the AG-150A to which the watt-hour meter is connected. When five or more AG-150A are used in a system, use electric amount count PLC method mentioned in 5-2-2.

- (2) When the energy-save level is set to 0 (It is always set to level 0 in an energy-save control method), energy-save control will not be performed for the indoor units that show a greater difference between the set temperature and indoor temperature than the value set in the window on the right. Make the setting when some type of energy-saving control is effective at energy-save level 0 and the level of comfort is high on priority list. (Choose between 3 to 9)

5-2-5 When From external system Method is used

<ul style="list-style-type: none">  PLC Software for Demand Input PAC-YG41CDA  Electric Amount Count Software PAC-YG11CDA  PI Controller PAC-YG60MCA  Remote AG-150A  From external system 	<div style="border: 1px solid black; padding: 5px;"> <p>3 °C : Temperature difference between set point and inlet. With this limit or greater difference, indoor units will not be controlled on level 0.</p> </div>
--	--

(1) When the energy-save level is set to 0 (It is always set to level 0 in an energy-save control method), energy-save control will not be performed for the indoor units that show a greater difference between the set temperature and indoor temperature than the value set in the window on the right.

Make the setting when some type of energy-saving control is effective at energy-save level 0 and the level of comfort is high on priority list. (Choose between 3 to 9)

5-2-6 Setting the Outdoor Unit Control Method (All methods)

Make the energy-save control setting for the outdoor units for each energy-save level.

Note: M-NET addresses are displayed on outdoor units of City multi type. M-NET addresses and group names are displayed on A-control units (Slim units).

Note: As for A-control outdoor units, only the inverter models can be put on the energy save control. Do not make the energy save settings for the constant speed models.

Control Level	Maximum Capacity					Control Time (per 30 minutes)				
4	100%	90%	80%	70%	60%	3	6	9	15	30
3	100%	90%	80%	70%	60%	3	6	9	15	30
2	100%	90%	80%	70%	60%	3	6	9	15	30
1	100%	90%	80%	70%	60%	3	6	9	15	30
0	100%	90%	80%	70%	60%	3	6	9	15	30

(1) Set the maximum operating capacity at each level. Normally, outdoor units operate at 100% capacity. The smaller the maximum operating capacity, the more energy will be saved.

Note: Energy-saving effects cannot be expected when the outdoor units are running with low load and are operating below the set capacity level.

Note: Do not use the capacity-save control with heat-accumulating units (ICE-Y) or Multi S units. On these units, always set the capacity to "100%."

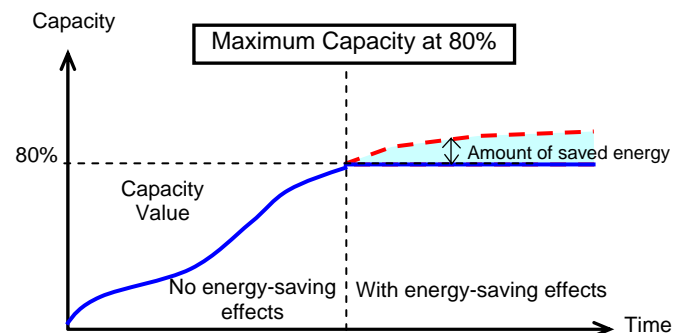

(2) Set the control time at each level. When a capacity-save control over outdoor units is performed, it is recommended that the control time be set to either 30 or 15 minutes, for shorter control time is not likely to bring much benefit.

If any time other than "30-minute" is selected, the control is done on rotation so as to avoid the overlapping of control time of the connected outdoor units as much as possible.

(3) To copy the settings for a certain outdoor unit to another outdoor unit, click [Copy] so the selected items are shown in yellow-green, and click [Paste] on the screen for the target outdoor unit.

To make settings for all the outdoor units at once, check [Batch Operations], and enter the settings. Uncheck [Batch Operations] by clicking on the box again to enable the individual setting of the outdoor units.

5-2-7 Setting the Indoor Unit Control Method (All methods)

Make the energy-save control settings for the Indoor units for each energy-save level.

The settings are made for each operation block. If the operation blocks have not been set up, refer to section 4-5 on how to set the operation blocks.

Control Level Block 1 Lobby(1F)

Control Level	Control Method	Control Time (per 30 minutes)
4	None ±2°C Fan OFF	3 6 9 15 30
3	None ±2°C Fan OFF	3 6 9 15 30
2	None ±2°C Fan OFF	3 6 9 15 30
1	None ±2°C Fan OFF	3 6 9 15 30
0	None ±2°C Fan OFF	3 6 9 15 30

Batch Operations

Control Method
Select indoor unit control method.

Control Time
Select the control time.

Copy
Click to copy the settings.

Paste
Click to paste the settings.

Batch Operations
Used to make settings for all Indoor units at once.

- (1) Set the control method for each level. Fan control can be performed without letting the users know that the energy-save control is performed because it performs thermo-off control of the indoor units and the mode display on the remote controller LCD will not change.

The modes on the K-control models and the models before free plan will change to "Fan."

Table 5-4 Indoor Unit Control Method

Control Method	Type of Control
N/A	No control is performed.
±2°C Control	Cooling/dry : +2°C; Heating : -2°C (No control during fan/auto) Note: Shifts to a ±2°C control at control begin time, and goes back to the normal setting at control end time.
Fan Control	Performs "capacity save 0% control (thermo OFF)" on free-plan indoor units and A-control slim indoor units, and performs fan operation control on the K-control units and the units before free-plan units. Note: Switches to thermo OFF or Fan mode at control begin time, and switches back to the original state at control end time.
Stop Control	Stops the indoor units Note: Sends [Stop] at control begin time, and goes back to the original run/stop status at control end time. Note: If set to [30 minutes][Stop], the groups that are being controlled cannot be operated from any controller.

- (2) Set the control time for each level.

The unit of control is 3 minutes. If "6 minutes" is selected, 3 minutes of control is performed twice during each 30 minute period

If any time other than "30-minute" is selected, the control is done on rotation so as to avoid the overlapping of control time of the connected outdoor units as much as possible.

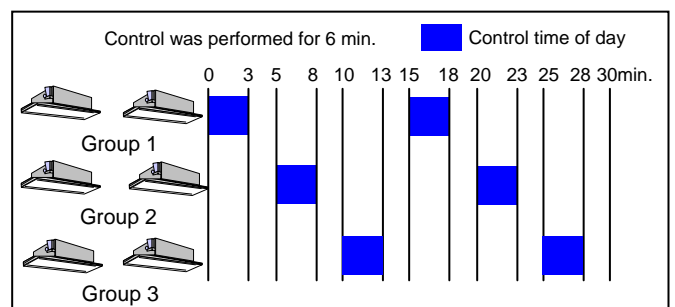

- (3) To copy the settings for a certain operation block to another operation block, click [Copy] so the selected items are shown in yellow-green, and click [Paste] on the screen for the target operation block.

To make settings for all the operation blocks at once, check [Batch Operations], and enter the settings. Uncheck [Batch Operations] by clicking on the box again to enable the individual setting of operation blocks.

- (4) Click [Save Settings] to send setting data to the AG-150A.

5-3 Settings for measurement

To measure the temperature or the amount of electricity, click the [Function1]-[Measurement] in the menu, and open the Measurement screen. Settings for controllers used for measurement can be made.

After the settings are made, click [Save Settings] to send setting data to AG-150A.

Note: If PAC-YG50ECA Expansion Controllers are connected, Expansion Controller system selection buttons will appear. Select the desired Expansion Controller (EC1, EC2, or EC3), and make the settings for each system. Make the settings with the Expansion Controllers properly connected.

Note: To use the measurement data for energy saving (peak cut) control, the energy saving (peak cut) license must be registered. Check that the license have been registered properly on the license registration screen (refer to chapter9). It is not necessary to register the license to display the present measurement data or trend graph or to send an error mail.

Note: If the user logs in as a building manager, some of the operations may be prohibited.

Note: When connecting AG-150A controllers by connecting an Expansion Controller to the system, measurement settings should be made only on one of the AG-150A controllers.

 **CAUTION** Measurement settings on Expansion Controllers (PAC-YG50ECA), when connected, must be made with the Expansion Controller properly connected to ensure proper settings.

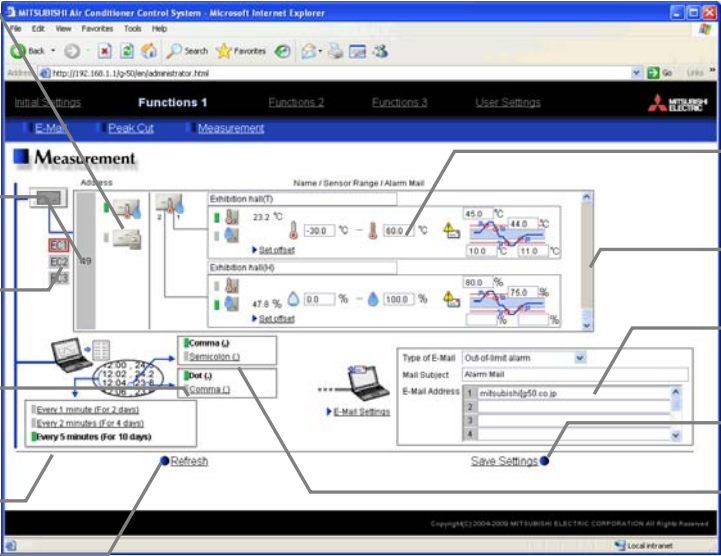

Selection of items to be measured
Select the items to be measured by sensors (such as temperature/humidity) or by meters (such as amount of electricity).

Address
Unit address will be displayed here.

Expansion Controller system selection buttons
Click to select the system to be set.

Selection of decimal point character
Select the decimal point character.

Trend interval
Select the data saving interval.

Refresh
Read setting data from AG-150A.

Setting details
Set the details for measurement.

Scroll bar
Switch the address.

Mail sending settings
Set the Type of E-Mail, Mail Subject, and E-Mail Address.

Save Settings
Send setting data to AG-150A.

Selection of separator character
Select the separator character for CSV file.

5-3-1 Registering AI controllers for temperature/humidity sensors

System settings for measurement sensors can be made. Up to two temperature/humidity sensors can be connected to one AI controller.

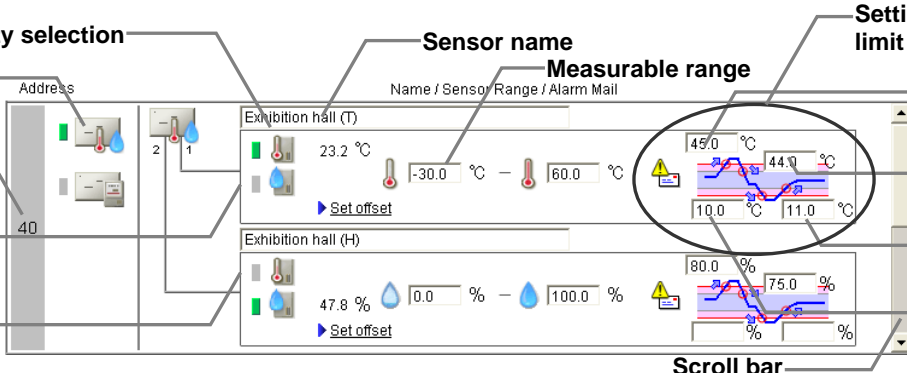

Temperature/humidity selection

Items to be measured

Address

Setting Details of sensor 1

Setting Details of sensor 2

Sensor name

Measurable range

Settings for upper/lower limit alarm

Upper limit (occurrence)

Upper limit (recovery)

Lower limit (recovery)

Lower limit (occurrence)



Scroll bar

(1) Use the scroll bar, and select the address to which the AI controller (PAC-YG63MCA) is connected.

(2) Select the icon of the AI controller () in the column of items to be measured.

Note: To disconnect the AI controller, click the icon of the AI controller that has been selected. The icon will be in unselected state.

(3) Enter the name of the sensor.

(4) Select either the temperature icon () or the humidity icon ().

(5) Enter the measurable range of the temperature or of the humidity.

Note: When the Pt sensor is connected, the range must be between -30°C and +60°C. When the sensors other than the Pt sensors are connected, enter the ranges that are described in the operation manuals.

(6) To receive an e-mail when the temperature or the humidity exceeds a certain value, set the upper/lower limit alarm values (occurrence, recovery).

Note: To avoid repeating occurrence and recovery, it is recommended that the difference between the occurrence value and the recovery value is approx. 1°C.

5-3-2 Adjusting the measured temperature/humidity values

When the adjustment of the measured values is necessary because of the location of the sensor, follow the procedures below.

Note: The present measurement value or the adjusted measurement value are not displayed until the connection settings of the AI controller are completed.

When the AI controller is registered for the first time, click the [Save Settings] button to send setting data, and click [Function 1]-Measurement] to display the screen again.

- (1) Click the [Set offset] in the [Setting details] section.
- (2) Select the adjustment value in the [Offset] pulldown or select the value to be desired in the [Modified value] pulldown.

The adjustable range is between -10.0°C and +10.0°C (-18.0°F and +18.0°F), -10.0% and +10.0%.

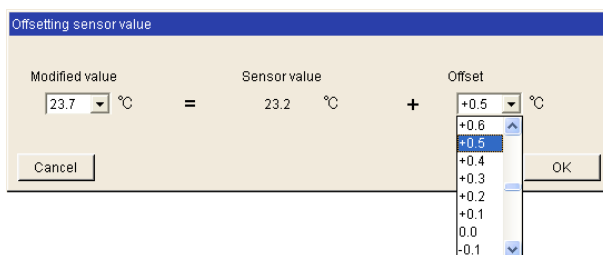

5-3-3 Registering PI controllers for measurement by meters

System settings for measurement meters can be made. Up to four meters can be connected to one PI controller (PAC-YG60MCA).

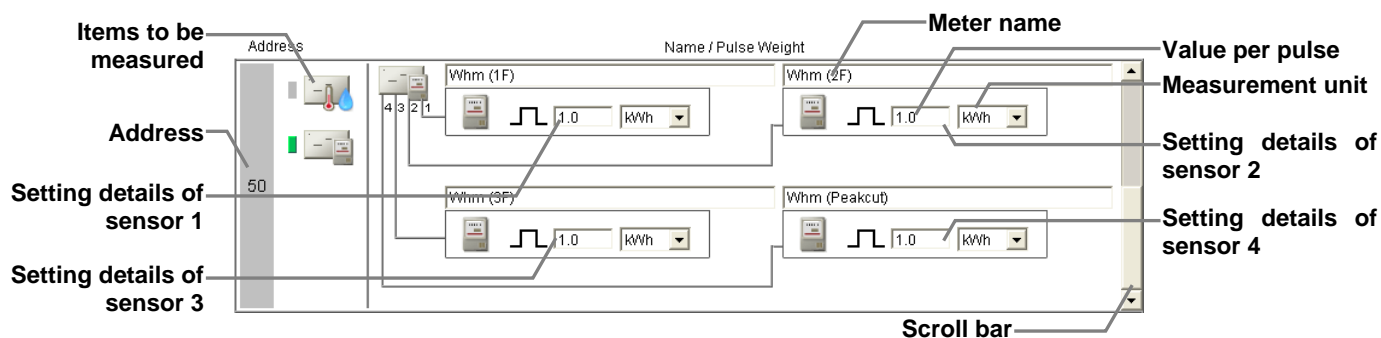

- (1) Use the scroll bar, and select the address to which the PI controller is connected.
- (2) Select the icon of the PI controller () in the column of items to be measured.

Note: To disconnect the PI controller, click the icon of the PI controller that has been selected. The icon will be in unselected state.

- (3) Enter the name of the meter.
- (4) Enter the value per pulse (measurement value per pulse) of the connected meter, and select the unit.

Note: The measurement unit can be selected between [kWh], [m3], [MJ] and [--(no unit)].

Note: Select the blank in the measurement unit pulldown for the meter not to be used.

Note: Set the value per pulse according to the measurement meter to be used. To check that the setting is correctly made, first check both the values measured by the measurement meter and by the measurement controller, and after a certain time, check that the both values have increased at equal increments. (The value measured by the measurement controller can be checked on the browser for the administrator.)

5-3-4 Setting the trend data format

The data format to be used when the trend graph data of the measured value is downloaded or is sent by e-mail can be set.

- (1) Select the separator character between [Comma (,)] and [Semicolon (;)].
- (2) Select the decimal point character between [Period (.)] and [Comma (,)].
- (3) Select the trend data interval between [1 minute (for 2 days)], [2 minutes (for 4 days)], and [5 minutes (for 10 days)]. The period of time that the trend graph can be displayed on the trend graph screen varies depending on the data interval.

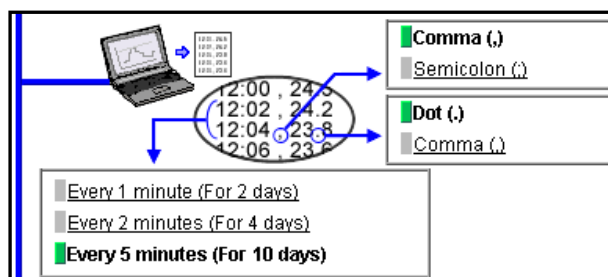

5-3-5 Setting the destination to which an error mail is sent

To receive an e-mail when the temperature or the humidity exceeds a certain value, make the error mail sending settings.

- (1) Select [Out-of-limit alarm] in Type of E-Mail pulldown, and enter the Mail Subject and the E-Mail Address.

Note: The following characters cannot be used in the mail title:
< > & " ' `

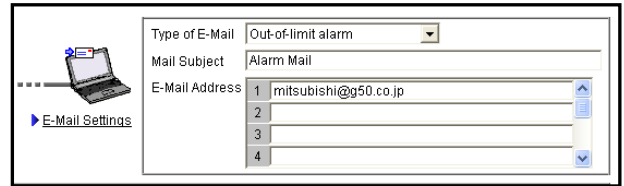

The following format will be applied when the alarm mail is sent.

```
From: Mitsubishi Building(000001)
Date/Time: 23/01/2007 09:38:39
Address: 50-1
Current value: 24.9 deg C
Status: Exceeded lower limit
Trend Data:
09:38 25.2 deg C
09:37 25.4 deg C
09:36 25.6 deg C
09:35 25.8 deg C
09:34 26.1 deg C
09:33 26.4 deg C
09:32 26.7 deg C
09:31 27.0 deg C
09:30 27.5 deg C
09:29 27.7 deg C
```

Item	Format
From	AG-150A name + Unit ID Note: Refer to section 4-2-1 for the settings of the AG-150A name and unit ID.
Date/Time	yyyy/MM/dd hh:mm:ss Note: The date format set in chapter 4-2-4 will be applied.
Address	M-NET address of AI controller + sensor No. Note: If an Expansion Controller is connected, the address will appear in the [Expansion Controller No. ()-[M-NET address of AI controller]-[Sensor No.] format.
Current value	Present temperature or humid (one place of decimals) Note: The present value may be [**.*] until the value measured by sensor becomes stable.
Status	" Exceeded upper limit ", " Recovered from upper limit ", " Exceeded lower limit ", or " Recovered from lower limit "
Trend Data	Time + Temperature or humidity (for the last 10 minutes)

- (2) Click the [E-Mail Settings] to set the mail server information.

Note: The setting details are the same as those mentioned in the chapter 5-1-1 and 5-1-2. Refer to those chapters.

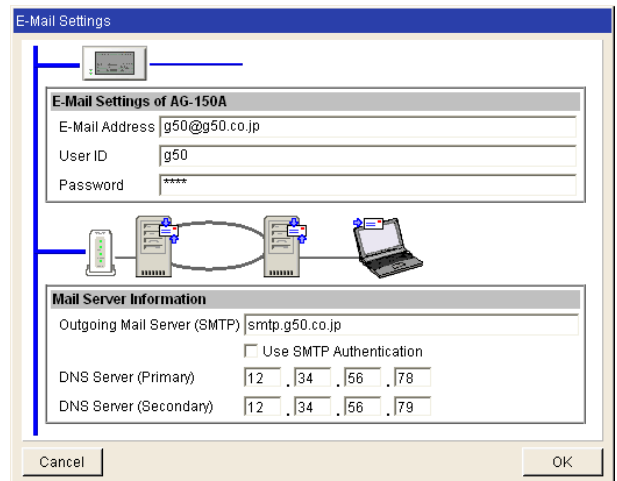

5-3-6 Setting the destination to which temperature/humid trend data mail is sent

To send temperature/humid trend data by mail once a day (when the date changes), make the mail sending settings. The trend data is sent as an attachment CSV file.

- (1) Select the [Trend Data] in the Type of E-Mail pulldown, and enter the Mail Subject and the E-Mail Address.

Note: The following characters cannot be used in the mail title:
< > “ ‘

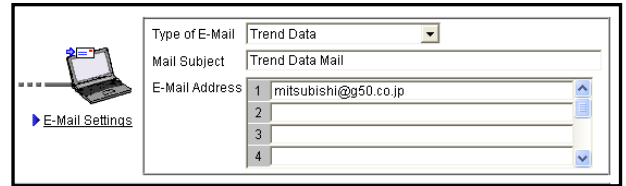

The following format will be applied to the attachment file attached to the mail that is sent when the date changes.

```
121
23/01/2007
Address 50-1
Time, Temperature(deg C)
00:00,20.3
00:05,20.1
00:10,19.8
00:15,19.3
:
23:50,18.8
23:55,18.5
```

Item	Format
File Type	121: Temperature data 122: Humidity data
Date	dd/MM/yyyy Note: The date format set in section 4-2-4 will be applied.
Trend target	M-NET address of AI controller + sensor No. Note: If an Expansion Controller is connected, the trend target will appear in the [Expansion Controller No. ()-[M-NET address of AI controller]-[Sensor No.] format.
Measured item	"Time, Temperature" or "Time, Humidity"
Data	Time + Measurement data Note: The data interval, separator character, decimal point character that are set in section 5-3-4 will be applied.

- (2) Click the [E-Mail Settings] to set the mail server information.

Note: The setting details are the same as those mentioned in the chapter 5-1-1 and 5-1-2. Refer to those chapters.

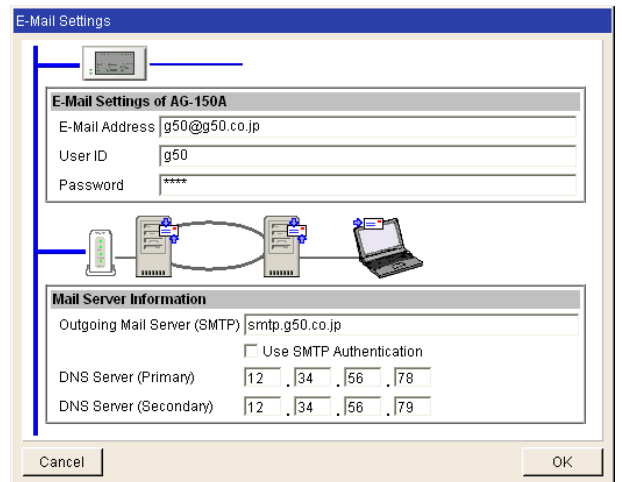

6 Functions 2

6-1 Limiting the Set Temperature Operating Range

Click on [Function2]-[Set Temperature Range Limit] in the menu to open the set temperature range limit screen, and make necessary settings to limit the set temperature operating range of the local remote controller.

Each user operation will be limited by setting the lower limit and the upper limit of the set temperature for cooling operation, which leads to energy saving.

Note: If PAC-YG50ECA Expansion Controllers are connected, Expansion Controller system selection buttons will appear. Select the desired Expansion Controller (EC1, EC2, or EC3), and make the settings for each system. Make the settings with the Expansion Controllers properly connected.

Note: The set temperature range can be limited on the following remote controllers. *1

- ME remote controller (PAR-F27MEA-E) : Lower limit for cooling mode and upper limit for heating mode
- ME remote controller (PAR-F27MEA-F) : Lower and upper limit for cooling, heating and automatic mode
- Simple ME controller (PAC-SE51CRA-F) : Lower and upper limit for cooling, heating and automatic mode
- MA remote controller (PAR-21MAA) *2 : Lower and upper limit for cooling, heating and automatic mode
- Simple MA controller (PAC-YT51CRB) *2 : Lower and upper limit for cooling, heating and automatic mode

*1: The operation mode that can be set varies depending on the unit model.

*2: This function cannot be used depending on the indoor unit model.

Note: The set temperature range for all modes can be limited on the browser operation screen (for administrator), AG-150A operation screen, and TG-2000A operation screen regardless of any settings being made. (The setting made on personal browser operation screen is in effect on the personal screen.)

Note: If the user logs in as a building manager, some of the operations may be prohibited.

Note: When connecting AG-150A controllers by connecting an Expansion Controller to the system, temperature range limit settings should be made only on one of the AG-150A controllers.



CAUTION Temperature range limit settings on Expansion Controllers (PAC-YG50ECA), when connected, must be made with the Expansion Controller properly connected to ensure proper settings.



Group No., group name
Group numbers and group names will be displayed.

Batch operations
Click to set all groups collectively.

Expansion Controller system selection buttons
Click to select the system to be set.

Copy
Click to copy the settings.

Paste
Click to paste the settings.

Set temperature range display
The set temperature range is displayed.

Save settings
Send setting data to AG-150A.

Refresh
Read setting data from AG-150A.

- Click the set temperature range display to display the setting screen. Set the temperature range for cooling, heating and automatic mode. Click [OK] to return the previous screen.

Note: When displayed in Fahrenheit, the temperature is displayed in 2°F steps.

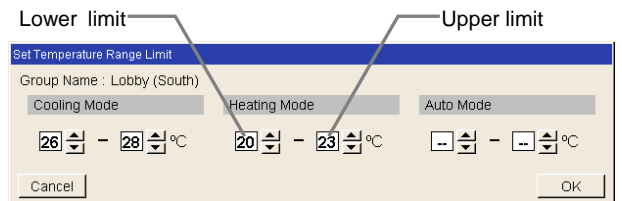

- Click [Save Settings] to send setting data to AG-150A.

Note: When copying settings of a group to another group, click [Copy] button. The screen will change to a selection screen (yellow-green). Click [Paste] on a group to be copied.

Note: When setting all groups collectively, click [Batch operation] button, and input settings.

6-2 Night Mode (Silent Mode) Schedule

Click on [Function2]-[Night Mode Schedule] in the menu to open the night mode schedule screen and make necessary settings to switch the outdoor unit operation mode to the night mode (low-noise operation), and set the night mode time interval.

Use this mode when low-noise operation of the outdoor unit is preferable during night.

Note: If PAC-YG50ECA Expansion Controllers are connected, Expansion Controller system selection buttons will appear. Select the desired Expansion Controller (EC1, EC2, or EC3), and make the settings for each system. Make the settings with the Expansion Controllers properly connected.

Note: Make this setting only when all the units operate normally. When connection error occurs at the indoor or the outdoor unit, night mode target units may not be displayed normally.

Note: The noise level to be reduced varies depending on the unit model.

Note: If the user logs in as a building manager, the operations may be prohibited.

Note: When connecting AG-150A controllers by connecting an Expansion Controller to the system, night-mode settings should be made only on one of the AG-150A controllers.

Night mode start time
Click to set the start time.

Night mode end time
Click to set the end time.

Target outdoor units
Click to select the outdoor unit, which performs night mode control.

Expansion Controller system selection buttons
Click to select the system to be set.

Refresh
Read setting data from AG-150A.

Save settings
Send setting data to AG-150A.

(1) Set the time interval in [Night mode start time] and [Night mode end time].

Note: When the starting time and the ending time is the same, night mode operation will always be performed.

(2) Select the outdoor unit, which performs night mode operation from [Target outdoor units].

Note: M-NET address numbers for each outdoor unit are displayed in the target unit field.

(3) Click [Save Settings] to send setting data to the AG-150A.

6-3 System-Changeover of Y series

Click on [Function2]-[Auto-changeover] in the menu to open the auto-changeover screen and make necessary settings to switch the operation mode between cooling and heating automatically of the indoor units connected to the same outdoor unit. Set the change over mode and the target units.

Please use this function when performing heating operation in the morning and cooling operation in the afternoon on air conditioners that either of cooling or heating operation is possible (Y series). The operation mode changes automatically without the need of operating all remote controllers.

Note: If PAC-YG50ECA Expansion Controllers are connected, Expansion Controller system selection buttons will appear. Select the desired Expansion Controller (EC1, EC2, or EC3), and make the settings for each system. Make the settings with the Expansion Controllers properly connected.

Note: The operation mode (cooling or heating) is set by the majority decision in consideration of performance value of each unit, or on the basis of the operation mode of the representative group. Therefore, some rooms may be hotter or colder than others.

Note: If the user logs in as a building manager, the operations may be prohibited.

Note: Set the indoor unit operation mode to [Auto] on the Auto-Changeover models (R2 series). (It is not necessary to change the mode on this screen.)

Note: When connecting AG-150A controllers by connecting an Expansion Controller to the system, auto-changeover settings should be made only on one of the AG-150A controllers.

Expansion Controller system selection buttons
Click to select the system to be set.

Member group
The group name that is connected to the outdoor unit is displayed here. When the representative group mode is selected, select the representative group among these member groups.

Changeover mode
The changeover mode is displayed here.

Refresh
Read setting data from AG-150A.

Save settings
Send setting data to AG-150A.

Target outdoor units
The M-NET address of the outdoor unit is displayed here.

(1) Select the change mode of the target outdoor unit. When selecting the representative group mode, select one representative group among the member groups.

Table 6-1 Change Mode List

Change mode	Content
None	Select this when the function is not used.
Averaging	The operation mode (cooling or heating) is set and changed by the majority decision in consideration of the set temperature, the room temperature difference of all groups connected to the target outdoor unit, and capacity value of each indoor unit.
Representative Group	Changes the set temperature of the representative group, and the operation mode of the member group in accordance with the temperature difference.

(2) Click [Save Settings] to send setting data to the AG-150A.

7 Functions 3

7-1 External Temperature Interlock

To use external temperature interlock, click [Function 3] on the menu, and then click [External Temperature Interlock]. Air conditioning group can be set for this control.

By setting this control on the air conditioning unit at an entrance, our physical shock (heat shock) caused by the extreme temperature difference can be reduced when entering into a building.

Note: If PAC-YG50ECA Expansion Controllers are connected, Expansion Controller system selection buttons will appear. Select the desired Expansion Controller (EC1, EC2, or EC3), and make the settings for each system. Make the settings with the Expansion Controllers properly connected.

Note: Connect our AI controller (PAC-YG63MCA) to measure outdoor temperature.

Note: This function works when the operation mode is [cooling] or [dry].

Note: When connecting AG-150A controllers by connecting an Expansion Controller to the system, external temperature interlock settings should be made only on one of the AG-150A controllers.

External Temperature Sensor
Select a sensor that measures outside temperature.

Group number, group name
Displays group number and group name.

Expansion Controller system selection buttons
Click to select the system to be set.

Set temperature variation range
Select a maximum additional temperature to the preset temperature.

Refresh
Read setting data from AG-150A.

Save settings
Send setting data to AG-150A.

(1) Click external temperature sensor area to choose the sensor. The area displays [controller address + sensor number + sensor name].

(2) Select a maximum additional temperature to the preset temperature for each air conditioning group. For example, when [+4°C] is selected and the preset temperature is 24°C, the maximum set temperature will rise to 28°C along with outdoor temperature rise. When [+2°C] is selected, the maximum set temperature will rise to 26°C.

(3) After the setting, click the Save Settings button to send the setting data to AG-150A. When external temperature interlock is active, the set temperature of air conditioning group is shown below.

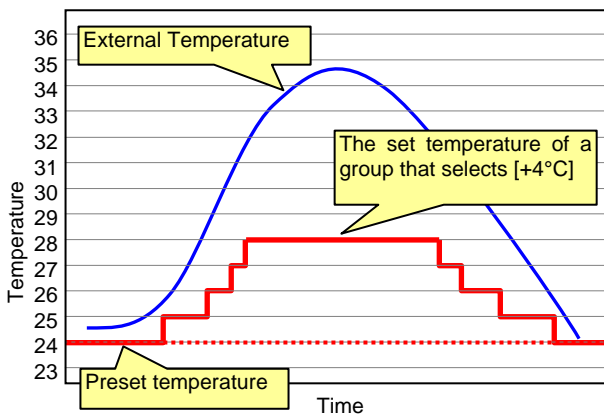

External Temperature	Set Temperature
External Temperature > Preset temperature+1.5°C	Preset temperature+1°C
External Temperature > Preset temperature+4.5°C	Preset temperature+2°C
External Temperature > Preset temperature+6.5°C	Preset temperature+3°C
External Temperature > Preset temperature+7.5°C	Preset temperature+4°C

7-2 Night setback control

To use Night setback control (abbreviated to setback control below), click [Functions 3] on the menu, and then click [Setback Control]. Air conditioning group can be set for this control.

This control prevents indoor dew by heating automatically when the room temperature goes outside of the specific range during the night.

Note: If PAC-YG50ECA Expansion Controllers are connected, Expansion Controller system selection buttons will appear. Select the desired Expansion Controller (EC1, EC2, or EC3), and make the settings for each system. Make the settings with the Expansion Controllers properly connected.

Note: This control starts heating operation when the control object group stops and the temperature drops below the Min. temperature. Also this control starts cooling operation when the control object group stops and the temperature rises above the Max. temperature.

Note: If the room temperature is measured by the air-conditioner's suction temperature sensor, the temperature may not be correct when the air-conditioner is inactive and the air is not fresh. When the temperature is not measured correctly, switch the sensor to external temperature sensor (PAC-SE40TSA / PAC-SE41TSA) or remote control sensor.

Note: When connecting AG-150A controllers by connecting an Expansion Controller to the system, set back settings should be made only on one of the AG-150A controllers.

Setback usability
Select setback usability.

Setback control period
Set the setback control period.

Group number, group name
Displays group number and group name.

Refresh
Read setting data from AG-150A.

Control temperature range
Max./Min. temperature for setback control can be set.

Expansion Controller system selection buttons
Click to select the system to be set.

Save settings
Send setting data to AG-150A.

(1) Select [Use] and set the setback control period.

Note: When [00:00 - 00:00] is set, setback control is active for 24 hours.

(2) Set the control temperature range (Max. and Min.) for each group. For example, suppose [01:00 - 05:00][12°C - --°C] is selected. In this case, heating operation starts automatically when the room temperature drops below 12°C between 1:00 to 5:00. When the control period is over at 5:00, the set temperature returns to the original and the operation stops.

Note: During setback operation after the temperature drops below the Min. temperature, when the control period is over or the room temperature rises to <Min. temperature + 3°C>, the setback control and air conditioning unit stop and the set temperature returns to the original. In the same way, during setback operation after the temperature rises above the Max. temperature, when the control period is over or the room temperature drops to <Max. temperature - 3°C>, the setback control and air conditioning unit stop and the set temperature returns to the original.

Note: When copying settings of a group to another group, click [Copy] button. The screen will change to a selection screen (yellow-green). Click [Paste] on a group to be copied.

Note: The CITY MULTI model supports a temperature setting range of 12-28°C / 53-83°F when in Heat mode. (When S series (PUMY) is used, set the temperature at 17°C-28°C / 63-83°F in heat mode.)

(3) Click [Save Settings] to send setting data to AG-150A.

When setback control is active, air conditioning group operates as shown below.

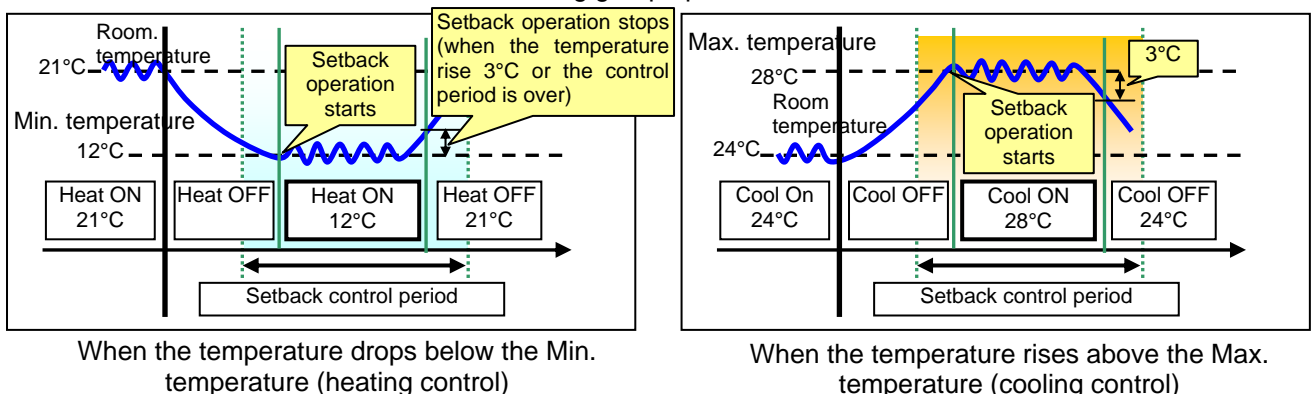

7-3 Interlock control

To use Interlock control, click [Functions 3] on the menu, and then click [Interlock control]. Interlock conditions and actions can be set.

After the settings are made, click [Save Settings] to send setting data to AG-150A.

Input category
Use this menu to select the input type.

Enable/Disable interlock control
Use these buttons to enable/disable the setback function.

Enable/Disable
Use these buttons to enable or disable each item.

Input state
Use this menu to set the interlocking conditions.

Select input units
Use this menu to display the screen on which to select input units.

Refresh button
Press this button to import the settings from AG-150A.

Output unit type
Use this menu to select the output unit type

Edit buttons
Use these buttons to insert, delete, clear, copy, and paste data.

Status bar
Shows the settings status for 150 conditions (Green: Settings have been made; Red: Incomplete settings exist.)

Action settings
Use this menu to select the type of interlocked actions.

Select output units
Use this menu to display the screen on which to select output units.

Scroll bar
Use the scroll bar to go up and down the page.

Save Settings button
Press this button to send the settings to the AG-150A.

The interlock control verifies the state changes in an ascending order of No.1 to 150 every three to five seconds. When the conditions are met, the interlock action commands will be issued to the output units.

By registering an “Interlock Control” license for the AG-150A and making the settings for the input category, interlocking conditions, input unit type, output category, action type, and output unit type for conditions No. 1 through 150, the operation of the equipment that are connected to AG-150A can be interlocked with the operation of the indoor units.

Shown below are two examples of such interlocked operations.

Example 1: Interlocked operation of indoor unit and window through the free contact on an indoor unit

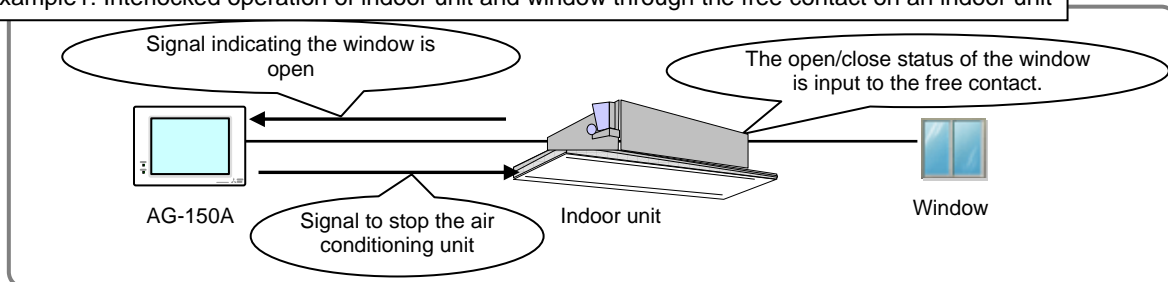

Example 2: Interlocked operation of indoor unit, lighting, and card key through the free contact of an indoor unit

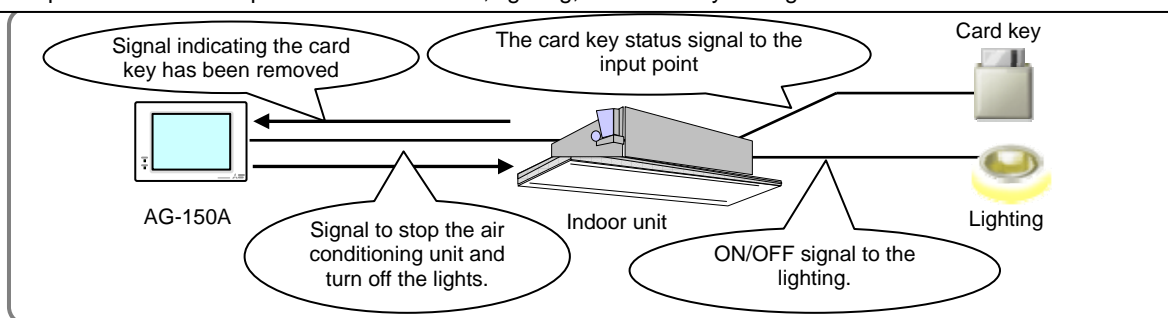

Example 3: Interlocked operation of indoor unit and card key via a DIDO controller

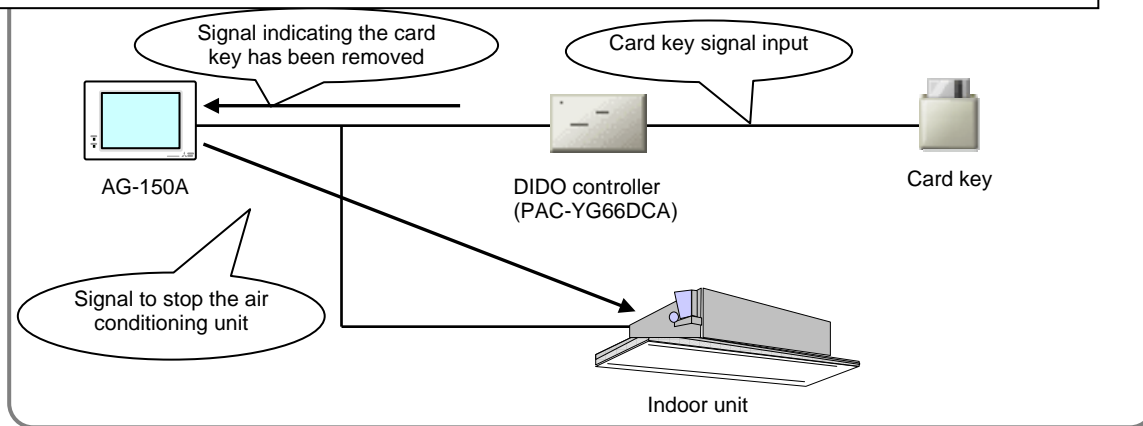

Note: It takes longer than usual to issue commands when the interlock conditions are met. This may delay the state change verification, which is usually performed every three to five seconds.

When other controls such as scheduled operation or Energy-Save Control are performed at the same time, the interlock control may be delayed. If PAC-YG50ECA Expansion Controllers are connected, communication may take longer and cause a delay of more than ten seconds. For instance, when all the 150 air conditioning units are set to ON using Expansion Controllers, the interlock control is delayed about one minute. Take into consideration these types of delays when setting the Interlock control.

Note: Interlock control is not effective when External Input Setting on AG-150A is set to ON/OFF (Level signal) (refer to 4-2-2-3).

Note: When the units are in the Emergency Stop mode (refer to 4-2-2-3) or in Stop Control method (refer to 5-2) during Energy-Save Control, only free contact and general interface (PAC-YG66DCA) will be performed and other Interlock control will not.

Note: To use this function, the Interlock control license must be registered. Check that the license has been registered properly on the license registration screen (refer to chapter 9).

Note: If the user logs in as a building manager, some of the operations may be prohibited.

Note: Free contact is available for use on R410A-compatible indoor units and R407C-compatible indoor units with S/W Ver. 33 or later. The S/W version can be confirmed with the maintenance tool.

Note: When connecting AG-150A controllers by connecting an Expansion Controller to the system, interlock control settings should be made only on one of the AG-150A controllers.

Note: When deleting a group or integrating a group with another group, also delete the interlock condition settings that correspond to that group.

Caution:

Before using the interlock control, you must agree to the following.

1. This feature must not be used for disaster prevention or security purposes unless a backup device is provided in case of failure of this feature. (Not designed to be used in situations that are life-threatening)
2. No functions must be added that allow the malfunctioning unit to run by defeating the safety features, such as an external ON/OFF switch or a short-circuit.
3. Those settings for the function that are not supported by the interlocked units must not be made. All the settings must be made within the specified range.
(Failure to observe these precautions may result in malfunctions and failures.)
4. Perform a test run for interlock control, and confirm the correct settings and normal operation.
5. The system must be configured in the way that integrates the operation of the interlocked fire and emergency control systems.
6. The followings are the condition examples that should NOT be set.
<Inappropriate condition examples - repeating ON and OFF eternally>
Ex1: Turn off Group1 when Group1 is turned on.
Ex2: Turn on Group1 when Group1 is turned off.
These settings may damage the units by repeating ON and OFF.





7-3-1 Making the interlock settings

Up to 150 interlocking conditions from 1 through 150 can be set as follows.

(1) Set the input category and interlocking conditions.

Select the equipment for the input category and the interlocking conditions (event) according to Table 7-1.

Table 7-1 Interlocking conditions and the selection unit for each input category

INPUT CATEGORY	INPUT UNIT ICON	INTERLOCKING CONDITIONS (EVENT)		SELECTION UNIT
		CONDITION 1	CONDITION 2	
Group (On/Off)		All Groups On All Groups Off One or more Groups On One or more Groups Off	-	Group
Group (Mode)		All groups in the mode All groups out of the mode One or more groups in the mode One or more groups out of the mode	Cool, Heat, Dry Fan, Auto Heat Recovery (LOSSNAY), Auto (LOSSNAY) Bypass (LOSSNAY)	Group
Group (Error/Normal)		All units in error All units in normal operation One or more units in error One or more units in normal operation	-	Group
Free Input Points (On/Off)		All Units On All Units Off One or more Units On One or more Units Off	-	Unit (point)

Note: The events for output units are performed when the following state changes occurred on the input units.

<Examples of when the input category is set to Air-conditioner (On/Off):>

When [All On] is selected, the events are performed when the state changed from [One or more group Off] to [All On].

When [All Off] is selected, the events are performed when the state changed from [One or more group On] to [All Off].

When [One or more group On] is selected, the events are performed when the state changed from [All Off] to [One or more group On].

When [One or more group Off] is selected, the events are performed when the state changed from [All Off] to [One or more group Off].

(When AG-150A is powered on, even if a condition for a change in status is met, it does not count as an event.)

Note: Air conditioning units, LOSSNAY units, and DIDO controller (PAC-YG66DCA) are available for selection as the input unit type (Group (On/Off); Group (Mode), Group (Error/Normal)).

Note: Different types of groups (air conditioning units, LOSSNAY units, or DIDO controller (PAC-YG66DCA)) cannot be simultaneously selected as input unit types for each interlocking conditions.

Note: If Group (Mode) is selected for the input category, operation modes of the air conditioning units (Cool, Heat, Dry, Fan, Auto) and LOSSNAY units (Heat Recovery, Auto, Bypass) will all be displayed. If an operation mode is selected that cannot be used on the input unit (air conditioning or LOSSNAY units), interlocking conditions will not be met.

Note: Multiple inputs cannot be selected for a single interlocking condition.

Note: DIDO controller (PAC-YG66DCA) group cannot be selected as an input unit type if Group (Mode) was selected as the input unit type.

(2) Set the input unit.

Click [Select input units] to set the input unit type.

One of the following screens will appear that will allow the user to set the input unit types, depending on the “selection unit” that was selected from a list in Table 7-1 .

(2-1) Selection unit is “Group.”

When the Input category is set to Air- conditioner (On/Off) or Air-conditioner (Mode) or Air-conditioner (Alarm/Recovery), clicking the [Select Input Units] will bring up the window that displays the Group numbers. Click on the numbers corresponding to the Groups to be registered. All selected Groups will be shown with a yellow-green background.

To cancel the selection, click again. Deselected items will be shown with a gray background.

To register blocks of Groups, click [Select a Block]. The ones that are selected will be shown with a yellow-green background.

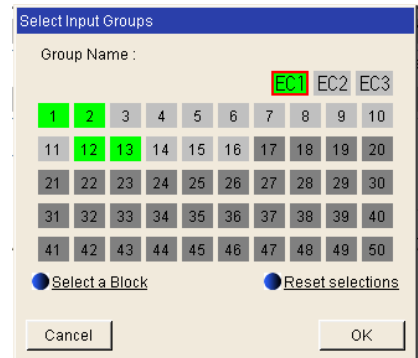

Clicking “Reset selections” will deselect all selected groups.

(2-2) Selection unit is “Unit.”

When the Input category is set to Free Input Points (On/Off),

clicking the [Select Input Units] will bring up the window that displays the free input points.

Click the addresses of the indoor units that are connected to the general equipment to be registered. The selected addresses will be displayed with a red frame. Select the contact point to which the general equipment is connected.

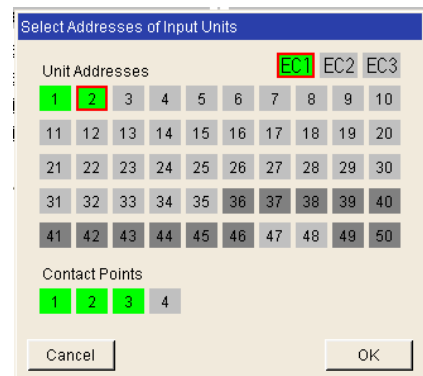



Note: If PAC-YG50ECA Expansion Controllers are connected, Expansion Controller system selection buttons will appear. Select the desired Expansion Controller (EC1, EC2, or EC3), and make the settings for each system. Make the settings with the Expansion Controllers properly connected.

(3) Set the output unit type and interlocked actions.

Select the equipment type for the output unit type and the interlocked actions according to Table 7-2.

Table 7-2 Interlocked actions and the selection unit for each output category

OUTPUT UNIT TYPE	OUTPUT UNIT ICON	INTERLOCKED ACTIONS		SELECTION UNIT
		ITEM	SETTING OPTIONS	
Group		ON/OFF	ON, OFF, Blank	Group
		Mode	Cool, Heat, Dry, Fan, Auto Auto, Heat Recovery (LOSSNAY), Auto (LOSSNAY), Bypass (LOSSNAY)	
		Set Temp.	14~30°C/57~87°F (Cool, Dry) 12~28°C/53~83°F (Heat Recovery) 17~28°C/63~83°F (Auto)	
		Air Direction	Horizontal, Down blow 0, Down blow 1, Down blow 2, Vertical, Swing, Auto	
		Fan speed	High, Mid1, Mid2, Low, Auto	
		Prohibit Remote Controller Operation (ON/OFF)	Prohibit, Permit	
		Prohibit Remote Controller Operation (Mode)	Prohibit, Permit	
		Prohibit Remote Controller Operation (Set Temp.)	Prohibit, Permit	
Free Input Point		ON/OFF	ON,OFF	Unit (point)

Note: Air conditioning unit, LOSSNAY unit, and DIDO controller (PAC-YG66DCA) groups are available for selection as the output unit type if Group was selected as the output unit type.

Note: Different types of groups (air conditioning units, LOSSNAY units, or DIDO controller (PAC-YG66DCA)) cannot be simultaneously selected as the output unit types for each interlocking conditions.

Note: If "Group" is selected for the output unit type, there may be settings that are unavailable (operation mode, set temperature range, air flow direction, fan speed), depending on the model of the connected air conditioning units.

Make the interlocked action settings only for the settings that are available for a given air conditioning unit group.

Setting the preset temperature outside of the air conditioning units' operable temperature range may lead to damage to the air conditioning units.

Note: The CITY MULTI model supports a temperature setting range of 12-28°C / 53-83°F when in Heat mode. (When S series (PUMY) is used, set the temperature at 17°C-28°C / 63-83°F in heat mode.)

(3-1) Output unit type is "Group."

Click "Action" to bring up the "Set up Action" screen.

Select the actions to be taken when an event occurs.

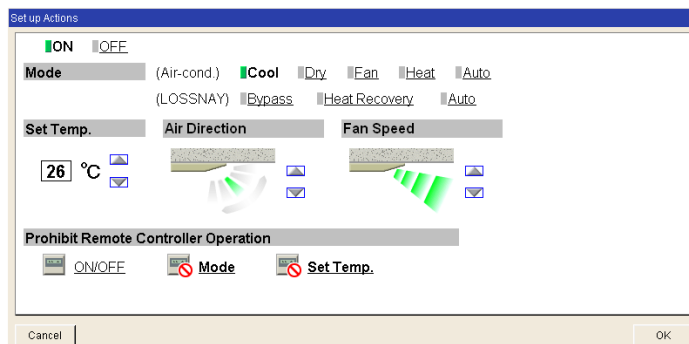

Note: Temperature setting cannot be made unless the operation mode has been set.

Note: If an operation mode is selected that is not available for a group of units that was selected in the output unit type field, the units in the group will not perform any operation.

Note: To prevent malfunctions of the air conditioning units, be sure to set the preset temperature to a temperature within the normal operating temperature range, although there may be rare cases in which it is possible to set the preset temperature to a temperature outside the normal operating temperature range (depending on the model of the air conditioning units that are connected to a system).

Note: Signals for Swing/AUTO and Fan speed/Auto will not be output unless these functions are available for a given air conditioning unit model.

With respect to the air flow direction and fan speed, if the number of settable directions and air speeds vary among the connected unit models, the signals that are rounded up to the settable range may be output.

Note: On K-control units, if the access to any item from the remote controller is prohibited, access to all items will be prohibited.

(3-2) Output unit type is "Free Contact."

Select ON or OFF on the interlocking action screen.

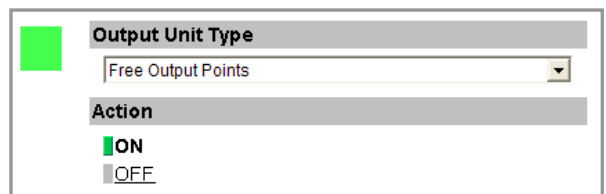

The screenshot shows a control interface with a green square icon on the left. The main area is divided into two sections: 'Output Unit Type' and 'Action'. Under 'Output Unit Type', there is a dropdown menu currently displaying 'Free Output Points'. Under 'Action', there are two radio button options: 'ON' (which is selected) and 'OFF'.

(4) Set the output unit type.

Click "Select output units" to bring up one of the following screens that will allow the user to set the output unit types, depending on the "selection unit" that was selected from a list in Table 7- 2 .

(4-1) Selection unit is "Group."

When the Output unit type is set to Air- conditioner, clicking the [Select Output Units] will bring up the window that displays the unit numbers.

Click on the numbers corresponding to the Groups to be registered. All selected Groups will be shown with a yellow-green background. To cancel the selection, click again. Deselected items will be shown with a gray background.

To register blocks of Groups, click [Select a Block]. The ones that are selected will be shown with a yellow-green background.

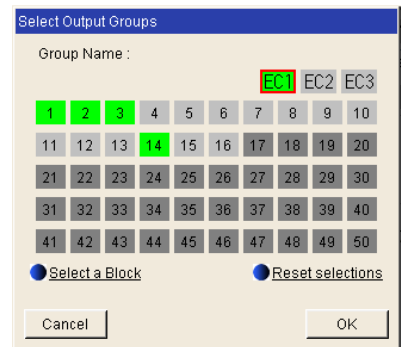

Clicking "Reset selections" will deselect all selected groups.

(4-2) Selection unit is "Unit."

When the Output unit type is set to Free Input Points (On/Off), clicking the [Select Input Units] will bring up the window that displays the free input points.

Click on the addresses of the indoor units that are connected to the general equipment to be registered. The selected addresses will be displayed with a red frame. Select the contact point to which the general equipment is connected.

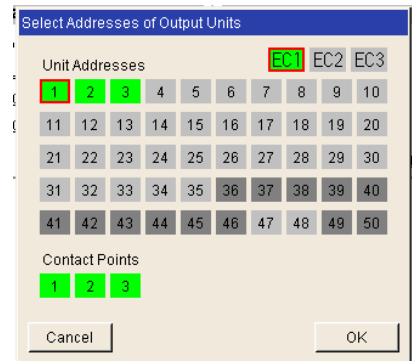

Note: If PAC-YG50ECA Expansion Controllers are connected, Expansion Controller system selection buttons will appear. Select the desired Expansion Controller (EC1, EC2, or EC3), and make the settings for each system. Make the settings with the Expansion Controllers properly connected.

7-3-2 Disabling/Enabling the setting for each interlocking condition

To exclude an individual group from certain settings being applied to, use the Enable/Disable button. No actions will be taken for the group that is set to "Disable."

7-3-3 Temporarily disabling the interlocking control

To temporarily disable the interlocking control, click the "Stop Execution" button.

*Changes in status that occur while "Stop Execution" is selected will be ignored.

7-3-4 Editing the setting for each condition

Use the edit buttons (Insert, Delete, Clear, Copy, Paste), to edit the setting in each row.

Button name	Function
Insert	Inserts a blank row above the row that is displayed, and moves all rows down by one. If conditions are entered in the last row, no more rows can be inserted
Delete	Deletes the row that is displayed, and moves up the rows below by one.
Clear	Clears the settings for the row that is displayed.
Copy	The copy button copies the settings in the selected row. These settings can be pasted onto another row by selecting a row and touching Paste.
Paste	

8 User Setting

Click on [User settings] in the menu to open the user setting screen and make necessary user settings to limit available functions of a building manager and to change user names and passwords of maintenance user and building manager.

A building manager must change group names when a tenant has been changed. However, for basic setting information, such as connection information of air conditioners, that one doesn't want to be changed, please make this user setting. Moreover, when building manager forgets his user name or password, the user logs in as a maintenance user can be set again.

Maintenance user name, password
User name and password can be changed.

Available functions
The building manager selects the available functions

Refresh
Read setting data from AG-150A.

User name and password for building manager
User name and password can be changed.

Save settings
Send setting data to AG-150A.

(1) When changing the user names or passwords of maintenance users, type new information in [User name], [New Password] and [Retype Password] fields to change user names or passwords of maintenance users.

Note: If the user logs in as a building manager, the user name and the password of the maintenance user are not displayed, and cannot be changed.

(2) When changing the user names or passwords of building managers, type new information in [User name], [New password] and [Retype Password] fields to change user names or passwords of a building manager.

(3) To set the available functions of a building manager, click functions that should be available. The ones that are selected will be shown with a yellow-green background.

To cancel the selection, click on them again. Deselected items will be shown with a gray background.

For more information of each function and available functions, refer to the next page.

Note: If the user logs in as a building manager, the present status can be checked, but cannot be changed.

▶ Available Functions

Initial Settings	
■ Date and Time	
■ <u>Basic System</u>	
■ Groups (■ Group Name ■ <u>Group Structure</u>)	
■ <u>Interlocked LOSSNAY</u>	
■ Blocks (■ Block Name ■ <u>Block Structure</u>)	
Functions 1	
■ <u>E-Mail</u>	
■ Peak Cut (■ Control Method ■ <u>System Structure</u>)	
■ Measurement	
Functions 2	
■ Set Temperature Range Limit	
■ Night Mode Schedule	
■ System-changeover	
Functions 3	
■ External Temperature Interlock	
■ Night Setback Control	
■ Interlock control	

Table 7-1 Available Function List

Function		Content	
Initial setting	Date and time		
	Current date and time setting		
	Basic system ^{*1}		
	AG-150A network setting, external output setting		
	Groups	Group name	Group name setting
		Group structure ^{*1}	Connection setting of indoor units, remote controllers, system controllers and general equipment in a group
Interlocked LOSSNAY ^{*1}		Connection setting of interlocked LOSSNAY	
Blocks	Block name	Block name setting	
	Block structure ^{*1}	Registration setting of groups in a block	
Functions1	E-Mail ^{*1}		
	Address to report an error mail, Setting of mail communication partner		
	Peak cut	Control method	Setting of average electric range, temperature difference between set point an inlet, and control method of indoor units and outdoor units
		System structure ^{*1}	PLC initialize, PLC settings
Measurement		Measurement controller connection setting, error mail setting	
Functions2	Set temperature range limit		
	Temperature operating range limitation setting		
	Night mode schedule		
Night mode time interval setting			
System-changeover		System-changeover of cooling and heating	
Functions3	Outdoor temperature control		
	Setting of external temperature interlock		
	Setback control		
Setting of setback control			
Interlock control		Setting of interlock control	

*1: At factory shipment, the operation of the building manager is prohibited.

(4) Click [Save Settings] to send setting data to the AG-150A.

9 Registering a License for Optional Function

Text below explains how to register a license for optional functions. In the Login screen (see3-1), click [License registration for optional functions] and the License Registration of Optional Functions screen will appear. Please ask the dealer you purchased the product from for more details on the optional functions and how to purchase a license number.

Note: When multiple AG-150A controllers are connected by connecting an Expansion Controller to the system, the license to use the optional functions is required only for the AG-150A controller on which the functions are actually used.

Sub menu
Click to return the Login page.

Optional functions selection box
Select the optional function you want to register.

License number entry field
Enter the license number required for registration.

Current status
This indicates whether the optional function is available for use.

Software version
Software version is displayed.

Register the license button
Click to register the license.

- Open the Registration of Optional Function screen.
Enter the Web page address in the web browser address field, and click the [Enter] (Return) key on the keyboard to display the Login screen (See 3-1). Click on this screen's menu item [Registration of Optional Functions] to open the Registration of Optional Functions screen.

License registration of optional functions

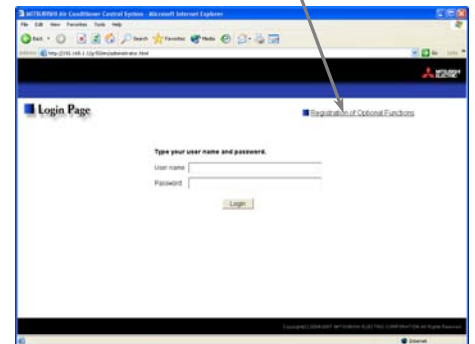

- Register an optional function.
First select the optional function you wish to register from the selection box in the Selecting Optional Function selection. When an optional function is selected, the current section will indicate whether it is available for use.
Next enter the license number you purchased for the optional function in the license number entry field and click the [Register the license] button. Once this is done, the optional function will be available for use.

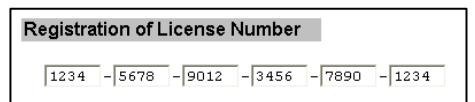
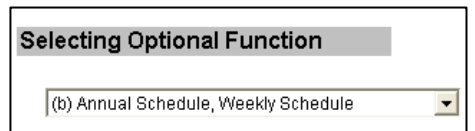

If you were unsuccessful in registering an optional function, check that you did not enter the wrong license number by mistake, that the correct optional function was selected from the selection box, and that the AG-150A main units date and time are set correctly.

This product is designed and intended for use in the residential,
commercial and light-industrial environment.

The product at hand is based on the following EU regulations:

- Low Voltage Directive 2006/95/EC
- Electromagnetic Compatibility Directive, 2004/108/EC

Please be sure to put the contact address/telephone number on
this manual before handing it to the customer.

 **MITSUBISHI ELECTRIC CORPORATION**

HEAD OFFICE: TOKYO BLDG. , 2-7-3, MARUNOUCHI, CHIYODA-KU, TOKYO 100-8310, JAPAN

WT05491X06