



HYDROBOX

EHSC series

EHPX series

INSTALLATION MANUAL

For safe and correct use, read this manual and the outdoor unit installation manual thoroughly before installing the hydrobox. English is the original language. The other language versions are translations of the original.

FOR INSTALLER

INSTALLATIONSHANDBUCH

Aus Sicherheitsgründen und zur richtigen Verwendung vor der Installation der Hydrobox die vorliegende Bedienungsanleitung und die Installationsanleitung der Außeneinheit gründlich durchlesen. Die Originalsprache ist Englisch. Die anderen Sprachversionen sind vom Original übersetzt.

FÜR INSTALLATEURE

MANUEL D'INSTALLATION

Pour une utilisation correcte et sûre, lisez soigneusement ce manuel et le manuel d'installation de l'appareil extérieur avant d'installer l'hydrobox. L'anglais est la langue originale. Les versions fournies dans d'autres langues sont des traductions de l'original.

POUR L'INSTALLATEUR

INSTALLATIEHANDLEIDING

Lees voor een veilig en juist gebruik deze handleiding en de installatiehandleiding van de buiten-unit aandachtig door voordat u met de installatie van de hydrobox begint. Engels is de oorspronkelijke taal. De andere taalversies zijn vertalingen van het origineel.

VOOR DE INSTALLATEUR

MANUAL DE INSTALACIÓN

Para un uso correcto y seguro, lea detalladamente este manual y el manual de instalación de la unidad exterior antes de instalar la Hydrobox. El idioma original del documento es el inglés. Las versiones en los demás idiomas son traducciones del original.

PARA EL INSTALADOR

MANUALE DI INSTALLAZIONE

Per un utilizzo sicuro e corretto, prima di installare l'Hydrobox leggere attentamente questo manuale e quello di installazione dell'unità esterna. Il testo originale è redatto in lingua inglese. Le altre versioni linguistiche rappresentano traduzioni dell'originale.

PER L'INSTALLATORE

MANUAL DE INSTALAÇÃO

Para uma utilização segura e correcta, leia este manual e o manual de instalação da unidade interior antes de instalar o cilindro. O idioma original é o inglês. As versões em outros idiomas são traduções do idioma original.

PARA O INSTALADOR

INSTALLATIONSMANUAL

Af hensyn til sikker og korrekt brug skal denne vejledning og vejledningen til udendørsenheden læses omhyggeligt, inden hydroboxenheden installeres. Engelsk er det oprindelige sprog. De andre sprogversioner er oversættelser af originalen.

TIL INSTALLATØREN

INSTALLATIONSMANUAL

För säker och korrekt användning, läs denna manual och utomhusenhetens installationsmanual innan du installerar hydroboxen. Engelska är originalspråket. De övriga språkversionerna är översättningar av originalet.

FÖR INSTALLATÖREN

INSTALLERINGSHÅNDBOK

For å sikre en trygg og riktig bruk skal du lese denne håndboken og installeringshåndboken for utendørsenheten grundig før du monterer hydroboksen. Engelsk er originalspråket. De andre språkversjonene er oversettelser av originalen.

FOR MONTØREN

ASENNUSOPAS

Lue turvallista ja asianmukaista käyttöä varten tämä opas ja ulkoyksikön asennusopas huolellisesti ennen hydroboxin asentamista. Alkuperäiskieli on englanti. Muut kieliversiot ovat alkuperäisen käännöksiä.

ASENTAJALLE

English

Deutsch

Français

Nederlands

Español

Italiano

Português

Dansk

Svenska

Norsk

Suomi

Contents

1. Safety Notices	2	4.4 Refrigerant Pipe work	16
2. Introduction	4	■ Precautions	16
■ Overview of the System	4	■ Connecting Pipes.....	16
■ How the Heat Pump Works.....	4	4.5 Electrical Connection	17
■ Overview of the Controls	5	5. System Set Up	22
3. Technical Information	6	5.1 DIP Switch Functions	22
■ Product specification.....	6	5.2 Connecting external input/output	23
■ Component Parts	7	■ Installation procedure for DHW tank.....	24
■ Technical Drawings	9	5.3 Remote Controller Options	26
■ Unit Compatibility	10	■ Remote Installation of Main Controller.....	27
4. Installation	11	5.4 Main Controller	28
4.1 Location	11	■ Setting the Main Control	30
■ Transportation and Handling.....	11	■ Initial Settings	30
■ Suitable Location	11	■ Main Settings Menu	30
■ Service access diagrams.....	11	■ Mode 1 - DHW/Legionella Prevention	31
■ Room Thermostat	11	■ Mode 2 - Heating	32
■ Repositioning	11	■ Mode 3 - Schedule timer.....	34
■ Mounting procedure.....	12	■ Service Menu.....	35
4.2 Water Quality and System Preparation	14	6. Commissioning	40
■ General	14	■ Pre-commissioning Checklist.....	40
■ New Installation	14	7. Service and Maintenance	41
■ Existing Installation	14	■ Basic Troubleshooting for Hydrobox.....	41
■ How to access Internal Components and Control Box.....	14	■ Annual Maintenance	41
4.3 Water Pipe work	14	■ Error Codes.....	41
■ Hot Water Pipe work.....	14	■ Engineers Forms	42
■ Hydraulic filter work (ONLY EHPT series).....	14	■ Annual Maintenance Log Book	43
■ Pipe work Connections	14	8. Supplementary information (Pump down) ...	44
■ Insulation of Pipe work.....	14		
■ Filling the System (Primary Circuit).....	14		
■ Sizing Expansion Vessels.....	15		
■ Water Circulation Pump Characteristics	15		
■ Safety Device Connections.....	15		

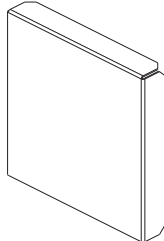
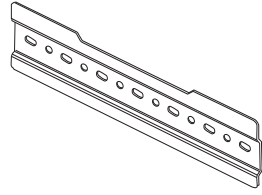
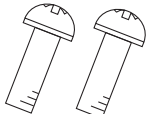
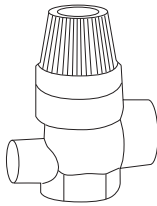
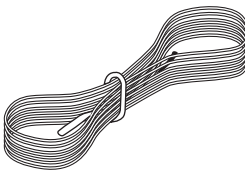
Accessories (Included)				
Main controller cover	Back plate	Screw M5×8	Pressure relief valve (3 bar)	Thermistor THW5B
				
1	1	2	1	1

Abbreviations and glossary

Abbreviations/Word	Description
Ambient temperature	The outdoor temperature
Freeze stat. function	Heating to prevent water pipes freezing
ASHP/HP	Air source heat pump
COP	Coefficient of Performance (i.e. the efficiency of the heat pump)
Hydrobox	Indoor unit housing the component plumbing parts (NO DHW tank)
DeltaT	Difference in temperature between two variables
DHW mode	Domestic hot water heating mode for showers, sinks, etc
Flow rate	Speed at which water circulates around the primary circuit
Flow temperature	Temperature at which water is delivered to the primary circuit
FTC3	Flow temperature controller, the circuit board in charge of controlling the system
Compensation curve mode	Space heating incorporating outdoor temperature compensation
Heating mode	Space heating through radiators or UFH
Legionella	Bacteria potentially found in plumbing, showers and water tanks that may cause Legionnaires disease
LP mode	Legionella prevention mode – a function on systems with tanks to prevent the growth of legionella bacterium
Packaged model	Plate heat exchanger in the outdoor heat pump unit
Refrigerant	A compound used within the heat cycle that goes through a phase change from gas to liquid
Split model	Plate heat exchanger in the indoor unit
TRV	Thermostatic radiator valve – a valve on the entrance or exit of the radiator panel controlling the heat output
UFH	Under floor heating – a system of water carrying pipes under the floor, that warms the floor surface

1 Safety Notices

Please read the following safety precautions carefully.

⚠ WARNING:
Precautions that must be observed to prevent injuries or death.

⚠ CAUTION:
Precautions that must be observed to prevent damage to unit.

This installation manual along with the user manual should be left with the product after installation for future reference.
Mitsubishi Electric is not responsible for the failure of locally or field-supplied parts.

- Be sure to perform periodical maintenance.
- Be sure to follow your local regulations.
- Be sure to follow the instructions provided in this manual.

⚠ WARNING

Mechanical

- The hydrobox and outdoor units must not be installed, disassembled, relocated, altered or repaired by the user. Ask an authorised installer or technician. If the unit is installed improperly or modified after installation by the user water leakage, electric shock or fire may result.
- The outdoor unit should be securely fixed to a hard level surface capable of bearing its weight.
- The hydrobox should be positioned on a hard vertical surface capable of supporting its filled weight to prevent excessive sound or vibration.
- Do not position furniture or electrical appliances below the outdoor unit or hydrobox.
- The discharge pipework from the emergency/safety devices of the hydrobox should be installed according to local law.
- Only use accessories and replacement parts authorised by Mitsubishi Electric and employ a qualified technician to fit the parts.

Electrical

- All electrical work should be performed by a qualified technician according to local regulations and the instructions given in this manual.
- The units must be powered by a dedicated power supply and the correct voltage and circuit breakers must be used.
- Wiring should be in accordance with national wiring regulations. Connections must be made securely and without tension on the terminals.
- Earth unit correctly.

General

- Keep children and pets away from both the hydrobox and outdoor units.
- Do not use the hot water produced by the heat pump directly for drinking or cooking. This could cause illness to the user.
- Do not stand on the units.
- Do not touch switches with wet hands.
- Annual maintenance checks on both the hydrobox and the outdoor unit should be done by qualified person.
- Do not place items containing liquid in on top of the hydrobox. If they leak or spill onto the hydrobox damage to the unit and or fire could occur.
- Do not place any heavy items on top of the hydrobox.
- When installing or relocating, or servicing the hydrobox, use only the specified refrigerant (R410A) to charge the refrigerant lines. Do not mix it with any other refrigerant and do not allow air to remain in the lines. If air is mixed with the refrigerant, then it can be the cause of abnormal high pressure in the refrigerant line, and may result in an explosion and other hazards.
- The use of any refrigerant other than that specified for the system will cause mechanical failure or system malfunction or unit breakdown. In the worst case, this could lead to a serious impediment to securing product safety.

⚠ CAUTION

- Use clean water that meets local quality standards on the primary circuit.
- The outdoor unit should be installed in an area with sufficient airflow according to the diagrams in the outdoor unit installation manual.
- The hydrobox should be located inside to minimise heat loss.
- Water pipe-runs on the primary circuit between outdoor and indoor unit should be kept to a minimum to reduce heat loss.
- Ensure condensate from outdoor unit is piped away from the base to avoid puddles of water.
- Remove as much air as possible from water circuit.
- Refrigerant leakage may cause suffocation. Provide ventilation in accordance with EN378-1.
- Be sure to wrap insulation around the piping. Direct contact with the bare piping may result in burns or frostbite.
- Never put batteries in your mouth for any reason to avoid accidental ingestion.
- Battery ingestion may cause choking and/or poisoning.
- Install the unit on a rigid structure to prevent excessive sound or vibration during operation.
- If power to the hydrobox is to be turned off (or system switched off) for a long time, the water should be drained.
- Preventative measures should be taken against water hammer, such as installing a Water Hammer Arrestor on the primary water circuit, as directed by the manufacturer.

1 Safety Notices

⚠ WARNING (SPLIT MODELS ONLY)

- Do not discharge refrigerant into the atmosphere if refrigerant leaks during installation, ventilate the room.
- Use appropriate tools for high pressure refrigerant.
- When pumping down refrigerant , stop the compressor before disconnecting the refrigerant pipes.
- During installation securely fasten the refrigerant pipes before starting the compressor.
- Check that refrigerant gas does not leak after the completion of installation.
- Use R410A refrigerant only. Do not allow air to enter the lines. Failure to observe these instructions will cause mechanical failure, system failure or, in the worst case, serious breach of product safety.

⚠ CAUTION (SPLIT MODELS ONLY)

- <Using R410A refrigerant heat pumps>
- Use C1220 copper phosphorus, for copper and copper alloy seamless pipes, to connect the refrigerant pipes. Make sure the insides of the pipes are clean and do not contain any harmful contaminants such as sulfuric compounds, oxidants, debris, or dust. Use pipes with the specified thickness. (Refer to 4.4.) Note the following if reusing existing pipes that carried R22 refrigerant.
 - Replace the existing flare nuts and flare the flared sections again.
 - Do not use thin pipes. (Refer to 4.4.)
 - Store the pipes to be used during installation indoors and keep both ends of the pipes sealed until just before brazing. (Leave elbow joints, etc. in their packaging.) If dust, debris, or moisture enters the refrigerant lines, oil deterioration or compressor breakdown may result.
 - Use ester oil, ether oil, alkylbenzene oil (small amount) as the refrigeration oil applied to the flared sections. If mineral oil is mixed in the refrigeration oil, oil deterioration may result.
 - Do not use refrigerant other than R410A refrigerant. If another refrigerant is used, the chlorine will cause the oil to deteriorate.
 - Use the following tools specifically designed for use with R410A refrigerant. The following tools are necessary to use R410A refrigerant. Contact your nearest dealer for any questions.

Tools (for R410A)	
Gauge manifold	Flare tool
Charge hose	Size adjustment gauge
Gas leak detector	Vacuum pump adapter
Torque wrench	Electronic refrigerant charging scale

- Be sure to use the correct tools. If dust, debris, or moisture enters the refrigerant lines, refrigeration oil deterioration may result.
- Do not use a charging cylinder. If a charging cylinder is used, the composition of the refrigerant will change and system efficiency will be reduced.

2 Introduction

The purpose of this installation manual is to instruct competent persons how to safely and efficiently install and commission the hydrobox system. The target readers of this manual are competent plumbers and/or refrigeration engineers who have the appropriate electrical competence/qualification and who have at-

tended and passed the requisite Mitsubishi Electric product training and have appropriate qualifications for installation of an unvented hot water hydrobox specific to their country.

Overview of the System

The Mitsubishi Electric Air to Water (ATW) for heat pump system with hydrobox consists of the following components; outdoor heat pump unit and indoor hydrobox incorporating the main controller.

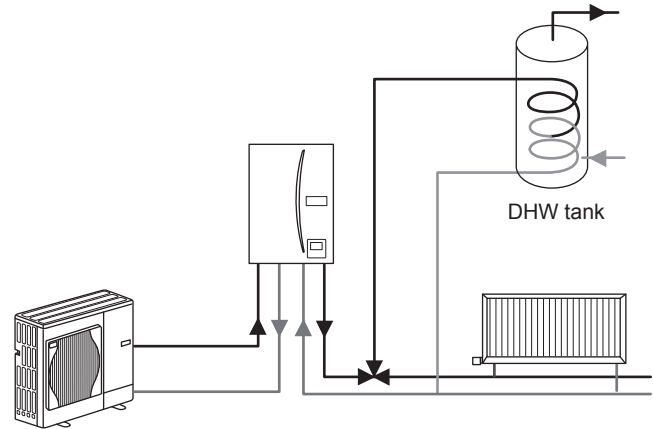

How the Heat Pump Works

Space heating and DHW

Heat pumps take electric energy and low grade heat energy from the outdoor air to heat refrigerant which in turn heats water for domestic use and space heating. The efficiency of a heat pump is known as the Coefficient of Performance or COP this is the ratio of heat delivered to power consumed. The heat pump operates most efficiently when generating low flow temperatures.

The operation of a heat pump is similar to a refrigerator in reverse. This process is known as the vapour-compression cycle and the following is a more detailed explanation.

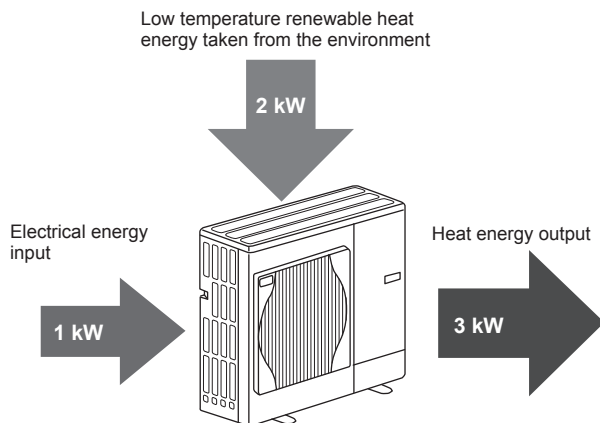
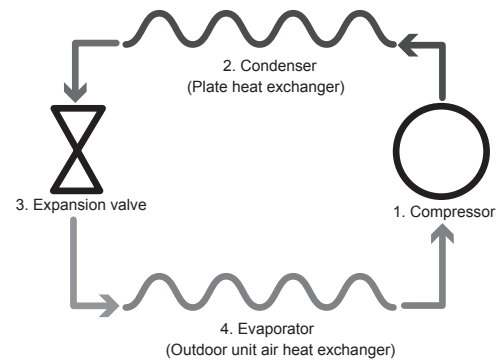

The first phase begins with the refrigerant being cold and low pressure.

1. The refrigerant within the circuit is compressed as it passes through the compressor. It becomes a hot highly pressurised gas. The temperature also rises typically to 60°C.
2. The hot refrigerant gas is then condensed as it passes across one side of a plate heat exchanger. Heat from the refrigerant gas is transferred to the cooler side (water side) of the heat exchanger. As the temperature of the refrigerant decreases its state changes from a gas to a liquid.
3. Now as a cold liquid it still has a high pressure. To reduce the pressure the liquid passes through an expansion valve. The pressure drops but the refrigerant remains a cold liquid.
4. The final stage of the cycle is when the refrigerant passes into the evaporator and evaporates. It is at this point when some of the free heat energy in the outside air is absorbed by the refrigerant.

It is only the refrigerant that passes through this cycle; the water is heated as it travels through the plate heat exchanger. The heat energy from the refrigerant passes through the plate heat exchanger to the cooler water which increases in temperature. This heated water enters the primary circuit and is circulated and used to serve the space heating system and DHW cylinder (if present in system).

2 Introduction

■ Overview of the Controls

Built into the front of the indoor unit is the Flow Temperature Controller3 (FTC3). This device controls the function of both the outdoor heat pump unit and the indoor unit. The advanced technology means that by using an FTC3 controlled heat pump you can not only make savings compared to traditional fossil fuel type heating systems but also compared to many other heat pumps on the market.

As explained in the earlier section, 'How the Heat Pump Works,' heat pumps are most efficient when providing low flow temperature water. The FTC3's sophisticated technology enables the room temperature to be kept at the desired level whilst utilising the lowest possible flow temperature from the heat pump.

The controller uses temperature sensors around the heating system to monitor the air and flow temperatures. This data is regularly updated and compared to previous data by the controller to predict changes in room temperature and adjust the heat pump output accordingly. By monitoring not only the outdoor ambient, but the room and water circuit temperatures, the heating is more consistent and sudden spikes in required heating are reduced. This results in a lower overall flow temperature being required.

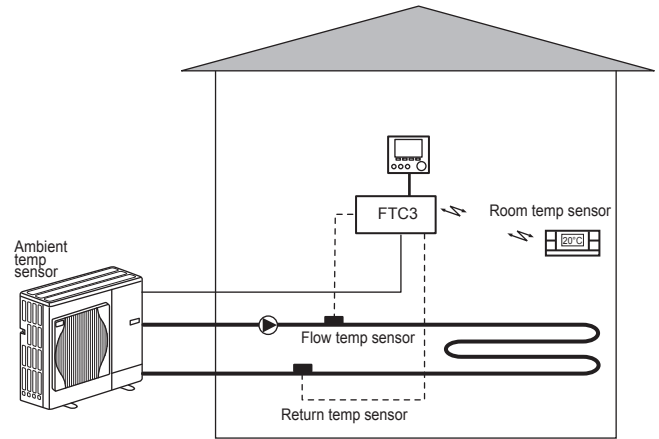

<How it works>

Temperature data is regularly received by the FTC3 from temperature sensors around the heating system. The most recent data is used with the previous temperature readings to predict the flow temperature required to keep the room temperature constant.

The room temperature sensor can either be wired or the Mitsubishi wireless remote controller can be used as it incorporates a temperature sensor. For more information on room temperature sensor options see section 'Remote Controller Options'. (Page 26)

3 Technical Information

Product specification

Model name	EHSC-VM6A		EHSC-VM9A		EHPX-VM2A	
Overall unit dimensions	800 x 530 x 360 mm (Height x Width x Depth)					
Weight (empty)	54 kg		54 kg		39 kg	
Weight (full)	60 kg		60 kg		44 kg	
Plate heat exchanger	✓		✓		X	
Unvented expansion vessel (Primary circuit)	Nominal volume 10 L					
Safety device	Water circuit (Primary)	Charge pressure 0.1 MPa (1 bar)				
	Booster heater	Control thermistor 1 - 80°C				
		Pressure relief valve 0.3 MPa (3 bar)				
		Flow switch Min flow 5.5 l/min				
		Control thermistor 80°C				
Manual reset thermostat 90°C						
Thermal Cut Off (for dry run prevention) 121°C						
Primary circuit circulating Pump	Grundfos UPSO 25-70 180					
Connections	Water	28 mm compression primary circuit				
	Refrigerant (R410A)	Liquid	9.52 mm		—	
Operating ambient condition	Electrical data	Gas	15.88 mm		—	
		0 (*1) - 35°C (≤ 80 %)				
	Control board	Power supply (Phase, voltage, frequency) Breaker (*when powered from independent source)				
		~N, 230 V, 50 Hz 10A				
Booster heater	Power supply (Phase, voltage, frequency)					
	~N, 230 V, 50 Hz					
	Capacity	2 kW+4 kW		3 kW+6 kW		
Current	26 A		13 A		9 A	
Breaker	32 A		16 A		16 A	

<Table 3.1>

*1 The environment must be frost-free.

Optional extras

- Wireless Remote Controller PAR-WT40R-E
- Wireless Receiver PAR-WR41R-E
- Remote sensor PAC-SE41TS-E

- Joint pipe (15.88 → 12.7) PAC-SH50RJ-E
- Joint pipe (9.52 → 6.35) PAC-SH30RJ-E

3 Technical Information

■ Component Parts

<EHSC> (Split model system)

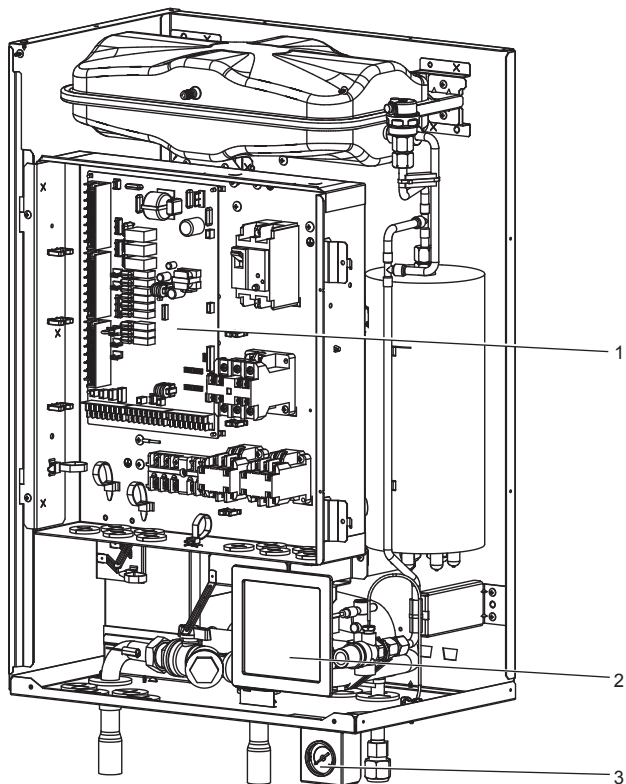

<Figure 3.1>

Number	Component
1	Control and electrical box
2	Main controller
3	Manometer
4	Expansion vessel
5	Expansion vessel charge valve
6	Automatic air vent
7	Booster heater
8	Drain cock
9	Water circulation pump
10	Pressure relief valve
11	Flow switch
12	Plate heat exchanger
13	Strainer valve
A	Inlet from space heating/Indirect DHW cylinder (primary return)
B	Outlet to space heating/Indirect DHW cylinder (primary flow)
C	Refrigerant (Liquid)
D	Refrigerant (Gas)
E	Discharge from pressure relief valve (installer to pipe connect to suitable drain point)

<Table 3.2>

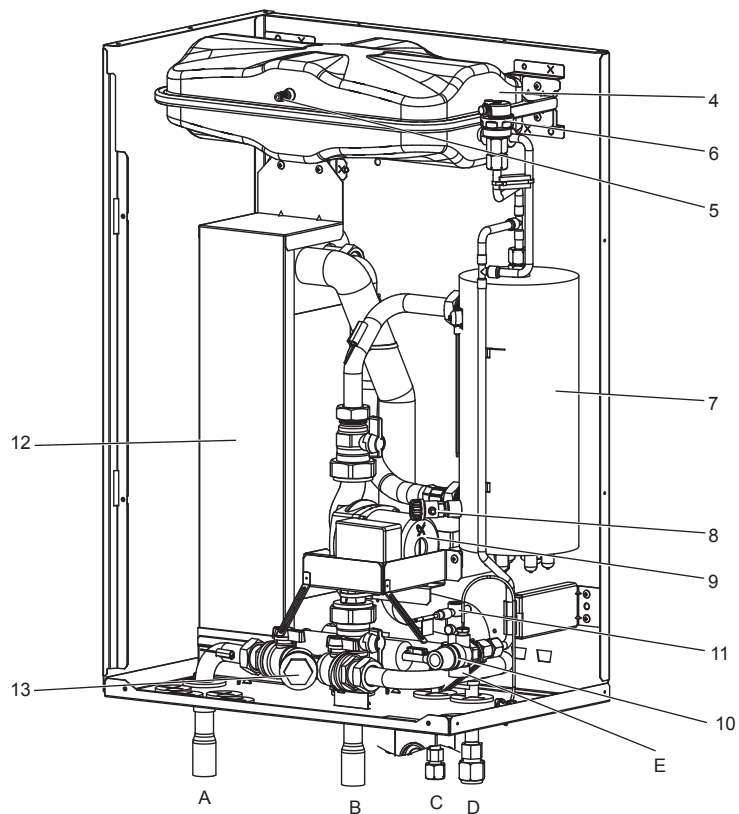

<Figure 3.2>

3 Technical Information

■ Component Parts

<EHPX> (Packaged model system)

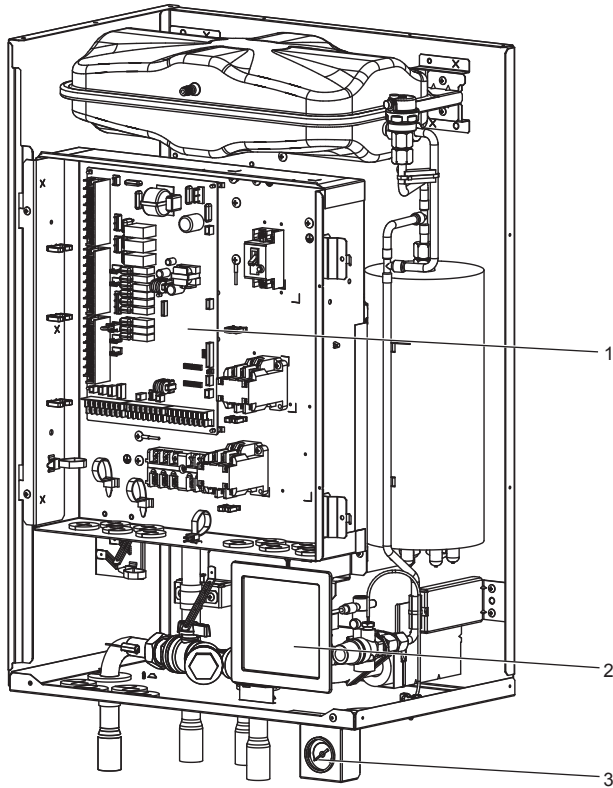

<Figure 3.3>

Number	Component
1	Control and electrical box
2	Main controller
3	Manometer
4	Expansion vessel
5	Expansion vessel charge valve
6	Automatic air vent
7	Booster heater
8	Drain cock
9	Water circulation pump
10	Pressure relief valve
11	Flow switch
13	Strainer valve
A	Inlet from space heating/Indirect DHW cylinder (primary return)
B	Inlet from heat pump
C	Outlet to heat pump
D	Outlet to space heating/Indirect DHW cylinder (primary flow)
E	Discharge from pressure relief valve (installer to pipe connect to suitable drain point)

<Table 3.3>

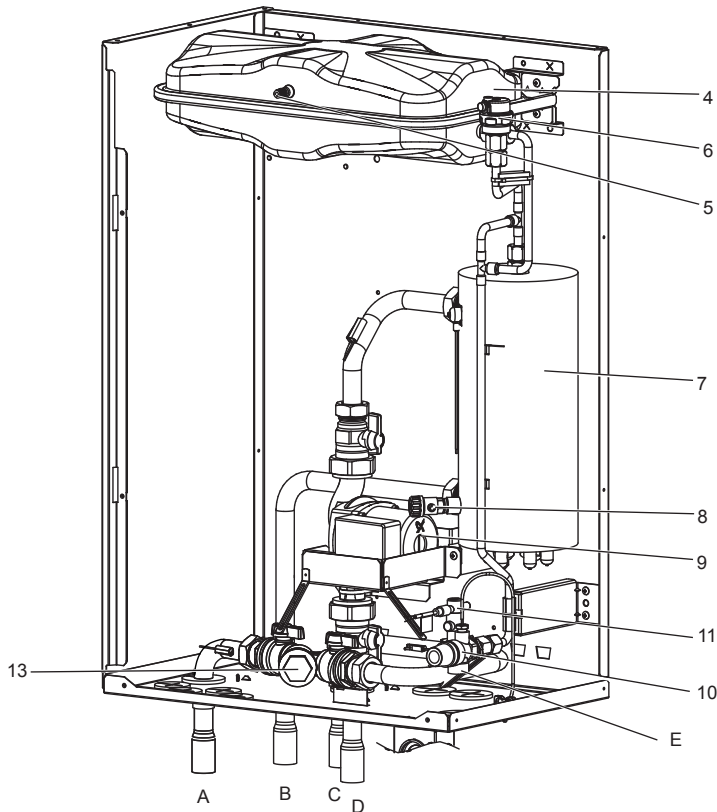

<Figure 3.4>

3 Technical Information

■ Technical Drawings

<EHSC> (Split model system)

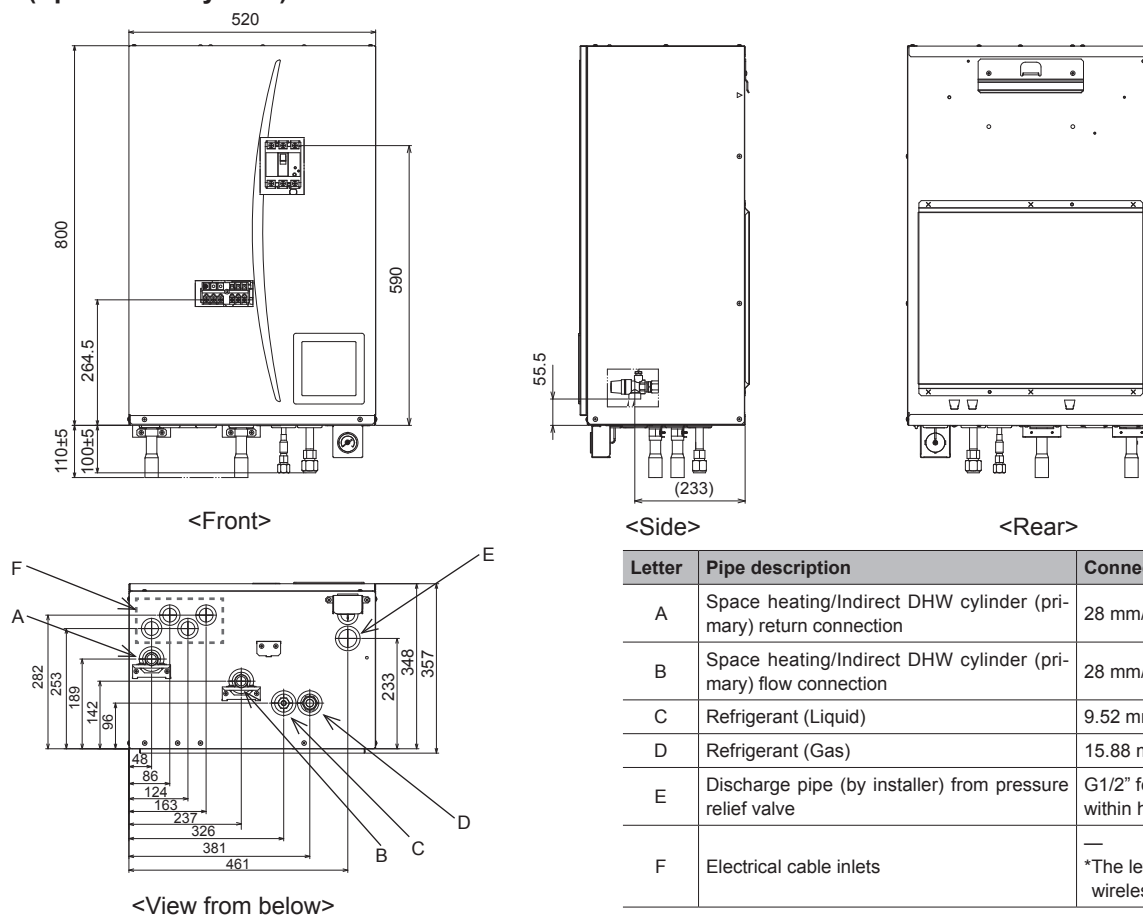

<Table 3.4>

<EHPX> (Packaged model system)

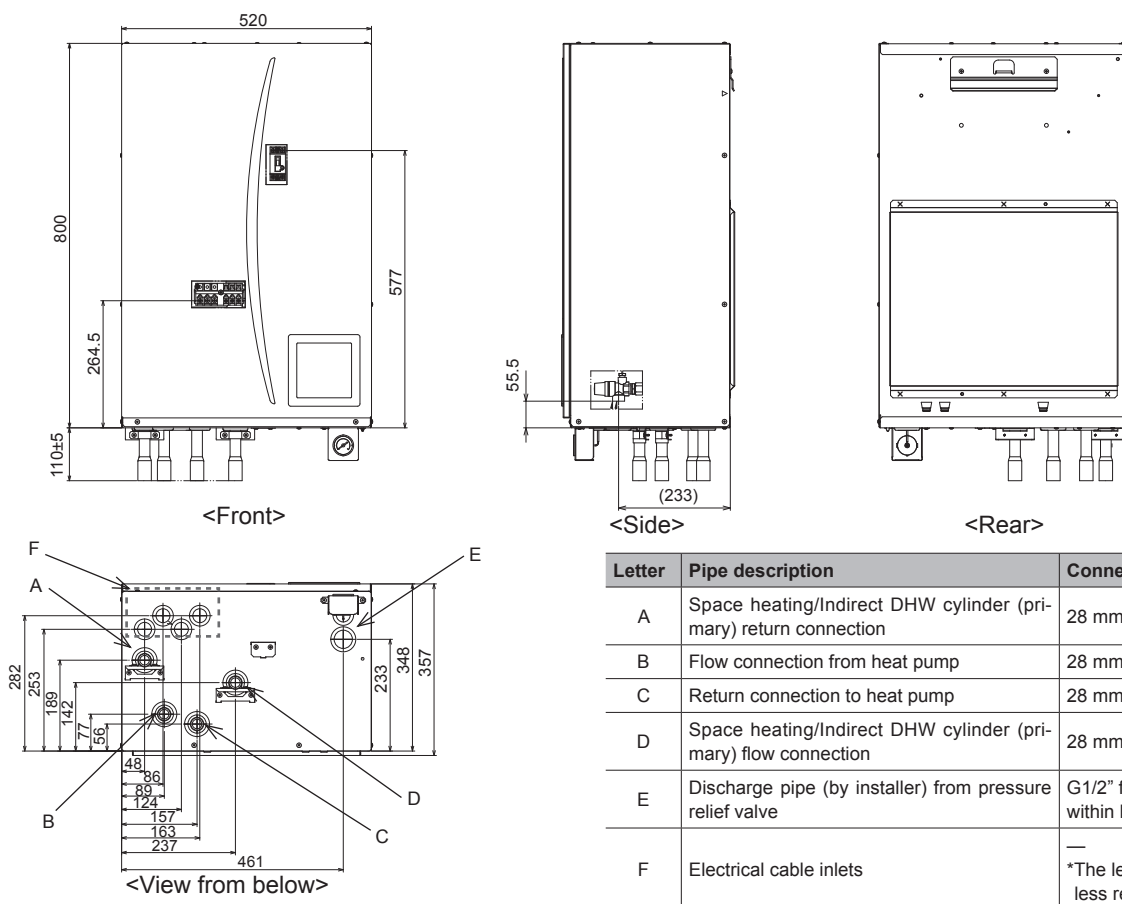

<Table 3.5>

3 Technical Information

Unit Compatibility

Hydrobox		EHSC-VM6A	EHSC-YM9A	EHPX-VM2A
Outdoor unit				
Packaged-type	PUHZ-W50-85 PUHZ-HW112-140			○
Split-type	PUHZ-RP35-140 PUHZ-HRP71-125	○	○	

<Table 3.6>

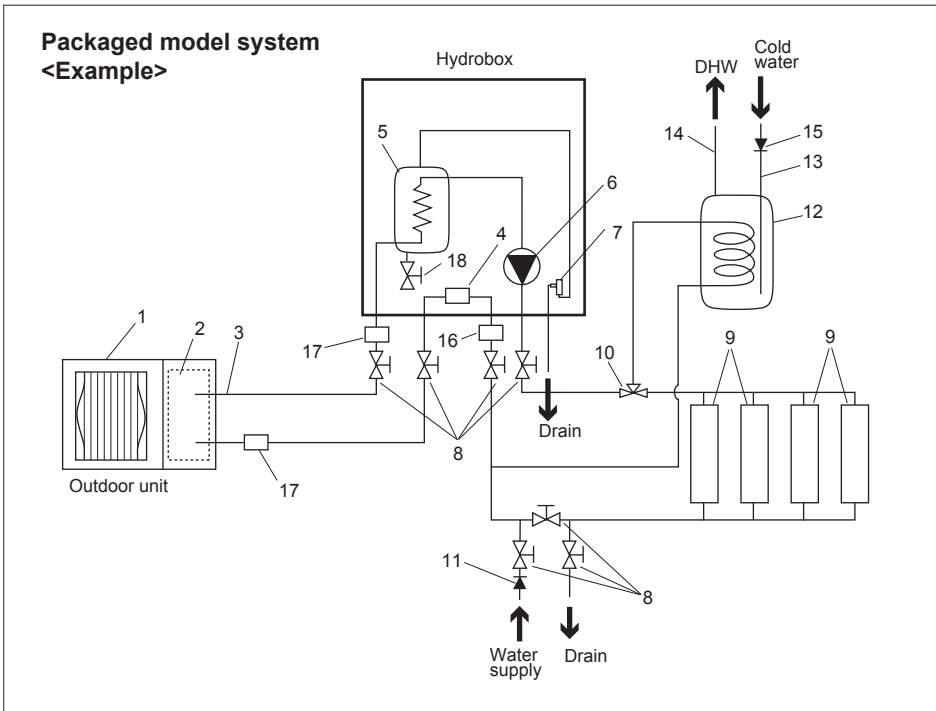

<Figure 3.5>

1. Outdoor unit
2. Plate heat exchanger
3. Interconnecting pipe work
Packaged model system—Water
Split model system—Refrigerant
4. Strainer
5. Booster heater
6. Water circulation pump
7. Pressure relief valve (discharge pipe by installer)
8. Isolating valve (field supply)
9. Heat emitters (e.g. radiator, UFH, fan coil)
10. 3-way valve (field supply)
11. Back flow prevention device
12. DHW indirect unvented cylinder (field supply)
13. Cold water inlet pipe (field supply)
14. DHW outlet connection (field supply)
15. Back flow prevention device (field supply)
16. **Magnetic filter is recommended. (field supply)**

For new pipework — FERNOX Boiler Buddy
For existing pipework — FERNOX Total Filter TF1

17. Strainer (field supply)
18. Drain cock (primary circuit)

Note

- Be sure to follow your local regulations to perform system configuration of the DHW connections.
- DHW connections are not included in the hydrobox package. All required parts are to be sourced locally.
- To enable draining of the hydrobox an isolating valve should be positioned on both the inlet and outlet pipework.
- Be sure to install a strainer, on the inlet pipe work to the hydrobox.
- Suitable drain pipework should be attached to all relief valves in accordance with your country's regulations.
- A backflow prevention device must be installed on water supply pipework (IEC 61770).
- When using components made from different metals or connecting pipes made of different metals insulate the joints to prevent a corrosive reaction taking place which will damage the pipework.

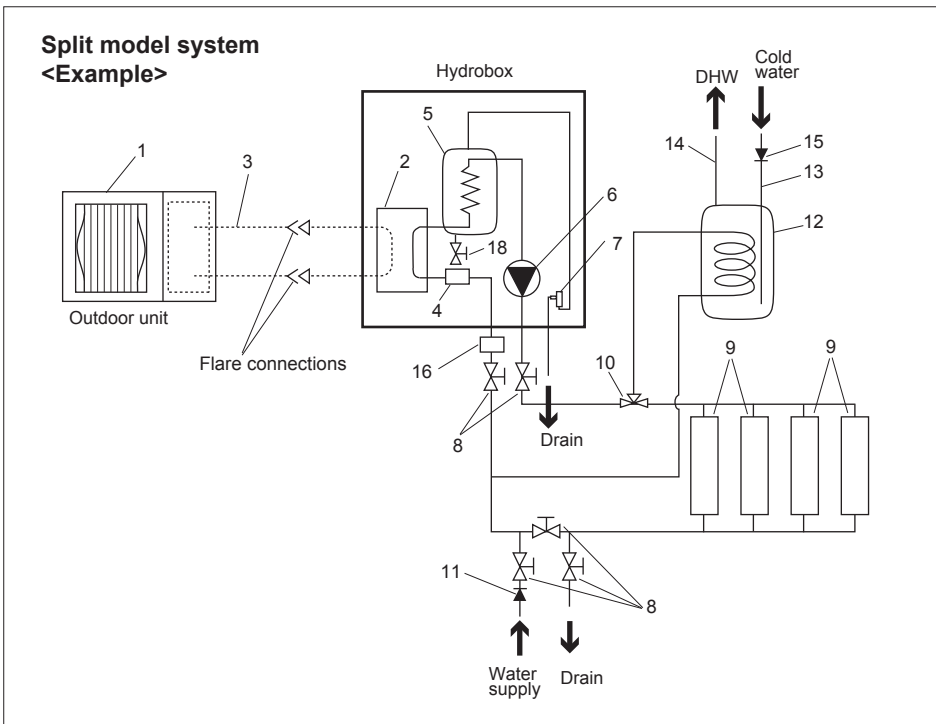

<Figure 3.6>

4 Installation

<Preparation before the installation and service>

- Prepare the proper tools.
- Prepare the proper protection.
- Allow parts to cool before attempting any maintenance.
- Provide adequate ventilation.
- After stopping the operation of the system, turn off the power-supply breaker and remove the power plug.
- Discharge the condenser before commencing work involving the electric parts.

<Precautions during service>

- Do not perform work involving electric parts with wet hands.
- Do not pour water or liquid into the electric parts.
- Do not touch the refrigerant.
- Do not touch the hot or cold surfaces of the refrigerant cycle.
- When the repair or the inspection of the circuit needs to be done without turning off the power, exercise great caution NOT to touch any live parts.

4.1 Location

■ Transportation and Handling

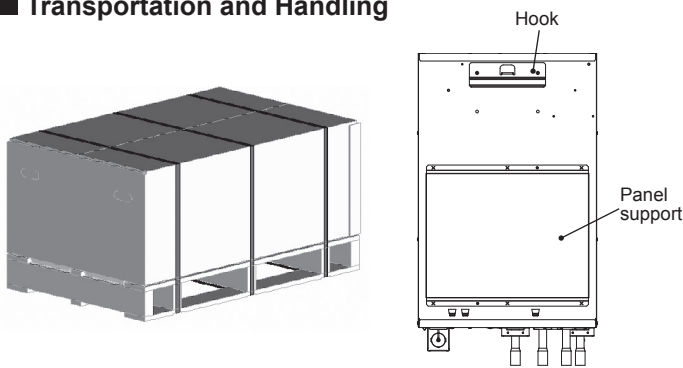

<Figure 4.1.1>

Hydrobox is delivered on a wooden pallet base with cardboard protection.

<Figure 4.1.2>

Care should be taken when transporting the hydrobox so that the casing is not damaged by impact. Do not remove the protective packaging until hydrobox has reached its final location. This will help protect the structure and control panel.

- The hydrobox should ALWAYS be moved by a minimum of 2 people.

■ Suitable Location

Before installation the hydrobox should be stored in a frost-free weatherproof location. Units must **NOT** be stacked.

- The hydrobox should be installed indoors in a frost free weather proof location.
- The hydrobox should be positioned on a level wall capable of supporting it's filled weight.
- To find out the weight, refer to "3. Technical Information".
- Care should be taken that minimum distances around and in front of the unit for service access are observed <Figure 4.1.3>.
- Secure the hydrobox to prevent it being knocked over accidentally or during earthquakes.
- The hook and panel supports should be used to fix the hydrobox to the wall. <Fig. 4.1.2>
- Install the hydrobox where it is not exposed to water/excessive moisture.

■ Service access diagrams

Service access	
Parameter	Dimension (mm)
a	200
b	150
c	500
d	500

<Table 4.1.1>

Sufficient space **MUST** be left for the provision of discharge pipework as detailed in National and Local building regulations.

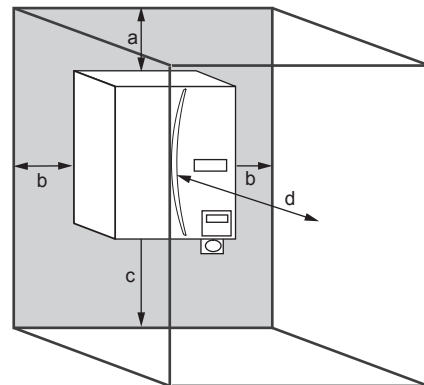

<Figure 4.1.3>

Service access

The hydrobox must be located indoors and in a frost-free environment, for example in a utility room.

■ Room Thermostat

If fitting a new room thermostat for this system;

- Position it out of direct sunlight and draughts
- Position it away from internal heat sources
- Position it in a room without a TRV on the radiator
- Position it on an internal wall

Note: Do not position the thermostat excessively close to the wall. The thermostat may detect the temperature of the wall, which could affect appropriate control of the room temperature.

- Position it approx. 1.5 m above floor level

■ Repositioning hydrobox

If you need to move the hydrobox to a new position **FULLY DRAIN** it before moving to avoid damage to the unit.

4 Installation

■ Mounting procedure

1. Install the included back plate accessory.

* When installing the back plate, use field-supplied screws and compatible fixing plugs.

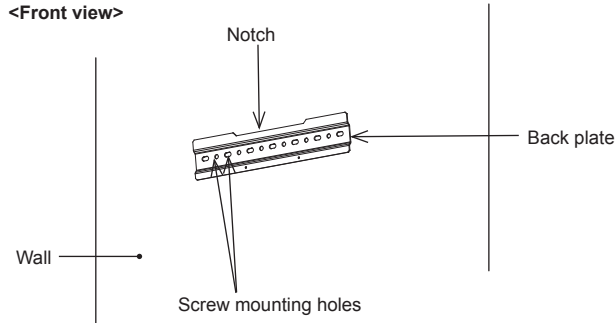

<Figure 4.1.4>

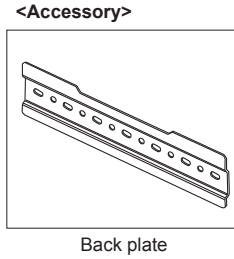

- Ensure that the notch is positioned at the TOP of the back plate. The back plate is provided with screw mounting holes that are round or oval. To prevent the unit from falling off the wall, choose the appropriate number of holes or hole positions and horizontally secure the back plate to the appropriate wall location.

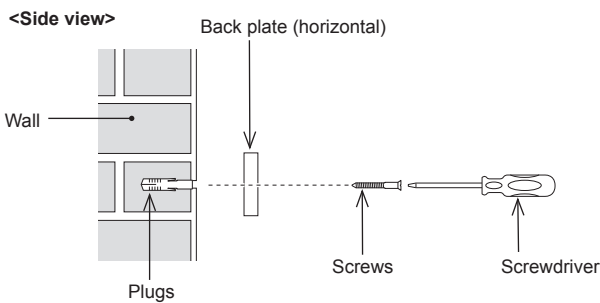

<Figure 4.1.5>

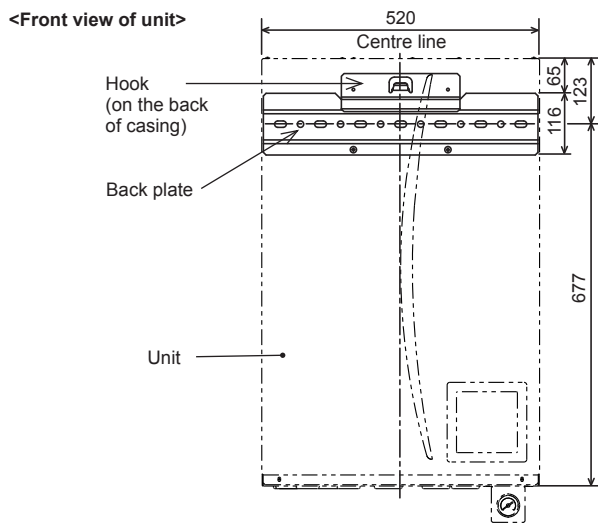

<Figure 4.1.6>

- Figure 4.1.6 shows the relative positions between the unit and the wall secured back plate. Referring to the <Figure 4.1.3> Service access, install the back plate.

2. Insert the hook on the back of the hydrobox behind the notch of the back plate.

*The lifting up of the hydrobox is facilitated by first tilting the unit forward using the included packaging cushioning.

Note: Hold the MAIN BODY of the hydrobox when carrying or mounting the hydrobox to a wall.

Holding and supporting the unit by the manometer, water pipe, or refrigerant pipe may result in breakdown of the components and impact on unit's conditions of warranty.

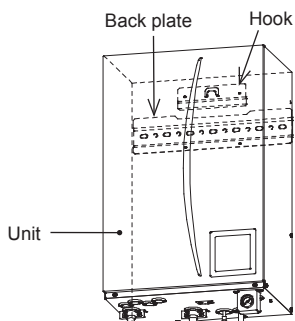

<Figure 4.1.7>

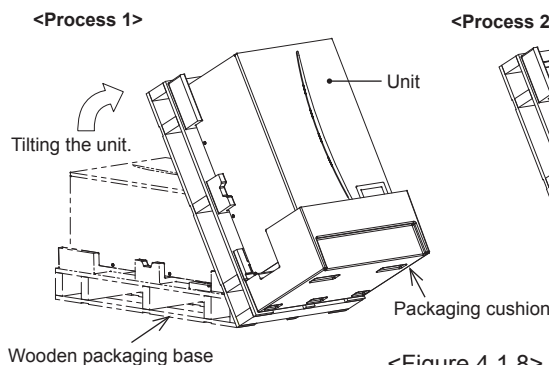

<Figure 4.1.8>

4 Installation

- i) Each of the right and left side panels has a ▷ mark indication.
Lift up the unit so that the ▷ marks are positioned above the top edge of the back plate as shown below.

<Side view of unit>

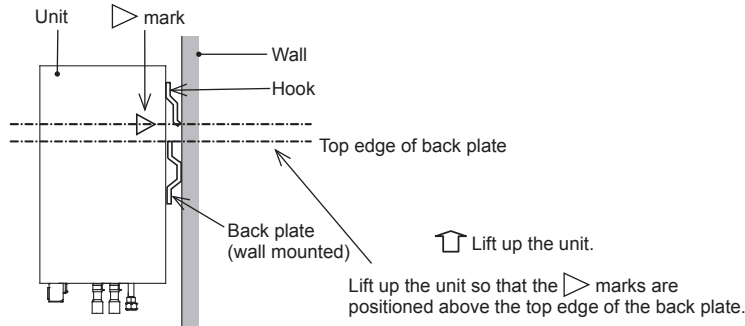

<Figure 4.1.9>

- ii) The back plate and the unit share the same width.
When mounting the unit, the centre lines of the back plate and the unit can be aligned by keeping the right and left edges of the back plate within the width of the unit. The hook on the unit can then be attached to the notch on the back plate. (When mounting, the casing's lower panel support should be in contact with the wall surface.)

<Front view of unit>

To assist in fixing the unit's hook on to the notch on the back plate, first line up the centre lines.

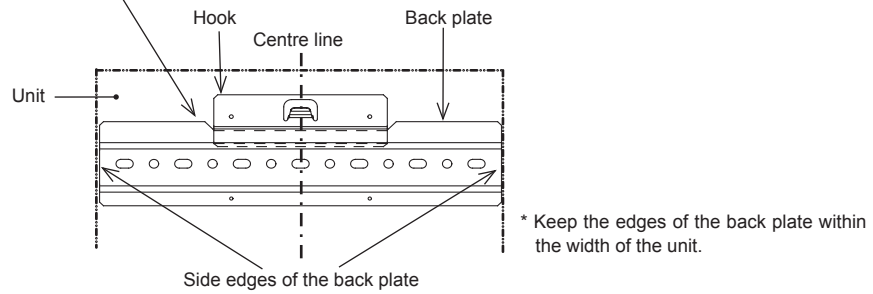

<Figure 4.1.10>

- iii) Check and ensure that the ▷ mark is positioned and properly engaged at the bent section level on the back plate as shown.

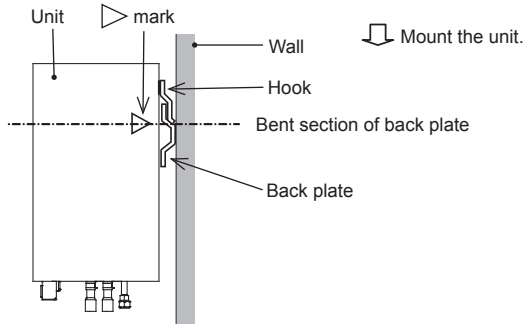

<Figure 4.1.11>

3. Referring to "■ How to access Internal Components and Control Box", fix the unit and the back plate using the included 2 screws (accessory items).

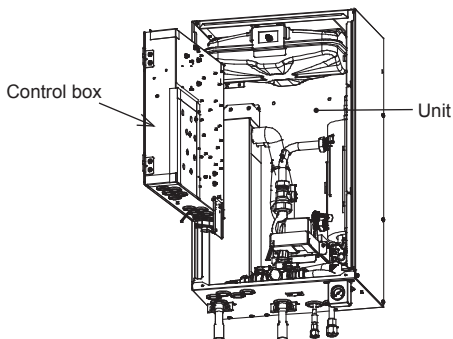

<Figure 4.1.12>

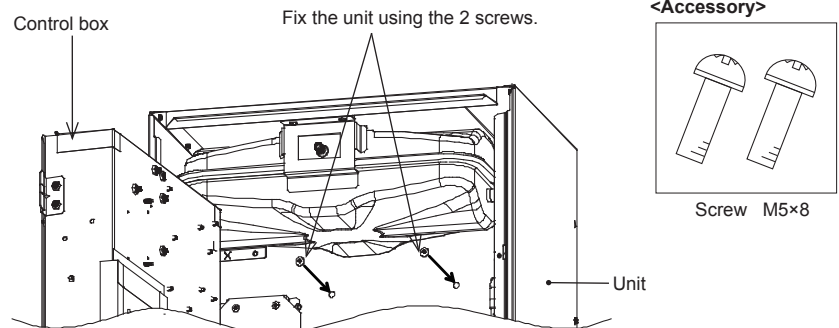

<Figure 4.1.13>

Caution) BEFORE performing field piping, be sure to fit and tighten these two screws. Otherwise, the hook could be disengaged, and the unit could fall down.

4 Installation

4.2 Water Quality and System Preparation

■ General

- Water quality should be to European Directive 98/83 EC standards.
 - pH value of 6.5-8.0 (Recommended: pH6.5 - 7.5)
 - Calcium \leq 100 mg/l
 - Chlorine \leq 100 mg/l
 - Iron/Manganese \leq 0.5 mg/l
- In installations where the hydrobox is used to generate domestic hot water (DHW) via an indirect unvented DHW cylinder the following instruction/advice should be observed:
In known hard water areas, to prevent/minimise scaling, it is beneficial to restrict the routine stored water temperature (DHW max. temp.) to 55°C.

■ New Installation

- Before connecting outdoor unit, thoroughly cleanse pipe work of building debris, solder etc using a suitable chemical cleansing agent.
- Flush the system to remove chemical cleanser.
- For all packaged systems add a combined inhibitor and anti-freeze solution to prevent damage to the pipe work and system components.
- For split systems the responsible installer should decide if anti-freeze solution is necessary for each site's conditions. Corrosion inhibitor however should always be used.

■ Existing Installation

- Before connecting outdoor unit the existing heating circuit **MUST** be chemically cleansed to remove existing debris from the heating circuit.
- Flush the system to remove chemical cleanser.
- For all packaged systems add a combined inhibitor and anti-freeze solution to prevent damage to the pipe work and system components.
- For split systems the responsible installer should decide if anti-freeze solution is necessary for each site's conditions. Corrosion inhibitor however should always be used.

When using chemical cleansers and inhibitors always follow manufacturer's instructions and ensure the product is appropriate for the materials used in the water circuit

■ How to access Internal Components and Control Box

<A> Opening the front panel

- Remove the two lower screws.
- Slide front panel upwards and open carefully.
- Disconnect main controller cable from quick release connector.**

 Opening the control box cover

- Remove the four screws.
- Remove the control box cover.

<C> Accessing the back of the control box

- The control box is hinged on the left hand side and has two holding screws on the right.
- Remove the two holding screws on the control box.
 - The control box can then be swung forward on the left hand hinges.

Note:

- Before accessing back of control box, release the associated cables from the tie straps attached to the cross-support.
- After servicing re-secure all cables using straps provided. Re-install main controller cable to its quick release connector then replace front panel and re-secure.

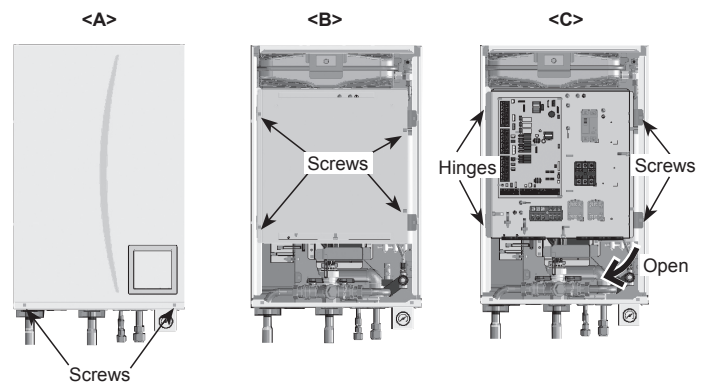

<Figure 4.2.1>

4.3 Water Pipe work

Note: Prevent the field piping from straining the piping on the hydrobox by fixing it to a wall or applying other methods.

■ Hot Water Pipe work

The function of the following safety components of the hydrobox should be checked on installation for any abnormalities;

- Pressure relief valve discharge
- Expansion vessel pre-charge pressure

The instruction on the following pages regarding safe discharge of hot water from Safety devices should be followed carefully.

- The pipe work will become very hot, so should be insulated to prevent burns.
- When connecting pipe work, ensure that no foreign objects such as debris or the like do not enter the pipe

■ Hydraulic filter work (ONLY EHPX series)

Install a hydraulic filter or strainer (field supply) at the water intake ("Pipe B" in Fig.3.4, also see associated schematic Fig. 3.5).

■ Filling the System (Primary Circuit)

Filling

- Check all connections including factory fitted ones are tight.
- Insulate pipe work between hydrobox and outdoor unit.
- Thoroughly clean and flush, system of all debris. (see section 4.2 for detailed instructions.)
- Fill primary heating circuit with water and suitable anti-freeze and inhibitor as necessary. **Always use a filling loop with double check valve when filling the primary circuit to avoid back flow contamination of water supply.**

■ Pipe work Connections

Connections to the hydrobox should be made using the 28 mm compression as appropriate.

Do not over-tighten compression fittings as this will lead to deformation of the olive ring and potential leaks. It is recommended that isolating valves are fitted on the flow and return water connections to enable easy future service and maintenance (see item 8 in figs 3.5 and 3.6.)

Note: To weld the pipes in the field, cool the pipes on the hydrobox using wet towel etc.

■ Insulation of Pipe work

- All exposed water pipe work should be insulated to prevent unnecessary heat loss and surface condensation.
- Cold and hot water pipe work should not be run close together where possible, to avoid unwanted heat transfer.
- Pipe work between outdoor heat pump unit and hydrobox should be insulated with suitable pipe insulation material with a thermal conductivity of \leq 0.04 W/m.K.

- Anti-freeze should always be used for package systems. It is the responsibility of the installer to decide if anti-freeze solution should be used in split systems depending on each site's conditions. Corrosion inhibitor should be used in both split and package systems.
- When connecting metal pipes of different materials insulate the joints to prevent a corrosive reaction taking place which will damage the pipework.

- Check for leaks. If leaks are found, retighten the screws on the connections.
- Pressurise system to 1 bar.
- Release all trapped air using air vents during and following heating period.
- Top up with water as necessary. (If pressure falls below 1 bar)

4 Installation

■ Sizing Expansion Vessels

To size the expansion vessel for the heating circuit the following formula and graph can be used.

$$V = \frac{\epsilon \times G}{1 + \frac{P_1 + 0.098}{P_2 + 0.098}}$$

Where;

- V : Necessary expansion vessel volume
- ϵ : Water expansion coefficient
- G : Total volume of water in the system
- P₁ : Expansion vessel setting pressure
- P₂ : Max pressure during operation

Graph below is for the following values

- ϵ : at 65 °C = 0.0198
- P₁ : 0.1 MPa
- P₂ : 0.3 MPa
- *A 30% safety margin has been added.

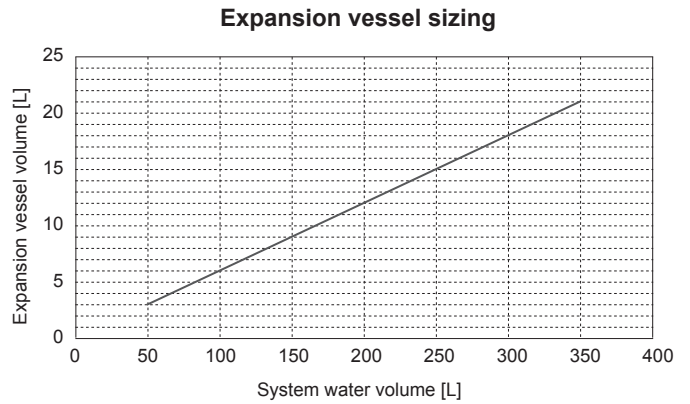

<Figure 4.3.1>

■ Water Circulation Pump Characteristics

Pump speed can be selected on the pump (see <Figure 4.3.2>). Adjust the pump speed setting so that the flow rate in the primary circuit is appropriate for the outdoor unit installed see Table 4.3.1. It may be necessary to add an additional pump to the system depending on the length and lift of the primary circuit.

<Second pump >

If a second pump is required for the installation please read the following carefully.

If a second pump is used in the system it can be positioned in 2 ways.

The position of the pump influences which terminal of the FTC3 the signal cable should be wired to. If the additional pump(s) have current greater than 1A please use appropriate relay. Pump signal cable can either be wired to TBO.1 1-2 or CNP1 but not both.

Option 1 (Space heating only)

If the second pump is being used for the heating circuit only then the signal cable should be wired to TBO.1 terminals 3 and 4 (OUT2). In this position the pump can be run at a different speed to the hydrobox's in-built pump.

Option 2 (Primary circuit DHW and space heating)

If the second pump is being used in the primary circuit between the hydrobox and the outdoor unit (Package system ONLY) then the signal cable should be wired to TBO.1 terminals 1 and 2 (OUT1). In this position the pump speed **MUST** match the speed of the hydrobox's in-built pump.

Note: Refer to 5.2 connecting external input/output.

Outdoor heat pump unit		Water flow rate range [L/min]
Packaged	PUHZ-W50	7.1 - 14.3
	PUHZ-W85	10.0 - 25.8
	PUHZ-HW112	14.4 - 27.7
	PUHZ-HW140	17.9 - 27.7
Split	PUHZ-RP35	7.1 - 11.8
	PUHZ-RP50	7.1 - 17.2
	PUHZ-RP60	8.6 - 20.1
	PUHZ-(H)RP71	10.2 - 22.9
	PUHZ-(H)RP100	14.4 - 27.7
	PUHZ-(H)RP125	17.9 - 27.7
	PUHZ-RP140	20.1 - 27.7

<Table 4.3.1>

* If the water flow rate is less than 7.1 L/min, the flow switch will be activated.
If the water flow rate exceeds 27.7 L/min, the flow speed will be greater than 1.5 m/s, which could corrode the pipes.

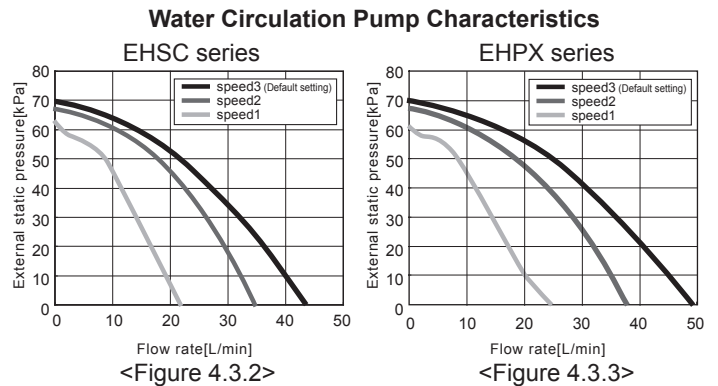

<Figure 4.3.2>

<Figure 4.3.3>

■ Safety Device Connections

The hydrobox contains a pressure relief valve. (see <Figure 4.3.4>) The connection size is G1/2" female. The installer **MUST** connect appropriate discharge pipework from this valve in accordance with local and national regulations. Failure to do so will result in discharge from the pressure relief valve directly into the hydrobox and cause serious damage to the product.

A pressure relief valve (3 bar) is supplied as a loose accessory with the hydrobox in addition to the pressure relief valve that is installed on the hydrobox. Install the pressure relief valve on the local piping connected to the space heating flow. The connection size is G1/2" (the drain connection size G1/2").

The space heating/indirect DHW cylinder primary flow can be identified on the pipe diagram label on the bottom of the hydrobox.

All pipework used should be capable of withstanding discharge of hot water. Relief valves should **NOT** be used for any other purpose, and their discharges should terminate in a safe and appropriate manner in accordance with local regulation requirements.

Note: Beware that the manometer and the pressure relief valve are **NOT** strained on its capillary side and on its inlet side respectively.

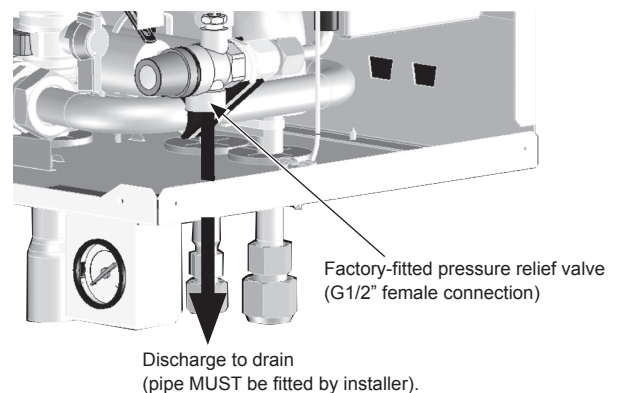

<Figure 4.3.4>

4 Installation

4.4 Refrigerant Pipe work (Split Model Systems only)

Note: Prevent the field piping from straining the piping on the hydrobox by fixing it to a wall or applying other methods.

Installation of refrigerant pipe work **MUST** only be done by a technician with relevant qualifications. Installation requirements may differ depending on the outdoor unit selected. Please also refer to outdoor unit installation manual when connecting refrigerant pipe work.

Gas side pipe size (mm)	Liquid side Pipe size (mm)
ø15.88	ø9.52

■ Precautions

For devices that use R410A refrigerant

- Use ester oil, ether oil or alkylbenzene oil (small amount) as the refrigeration oil applied to the flared sections.
- Use C1220 copper phosphorus for copper and copper alloy seamless pipes, to connect the refrigerant pipes. Use refrigerant pipes with the thicknesses specified in the table below. Make sure the insides of the pipes are clean and do not contain any harmful contaminants such as sulfuric compounds, oxidants, debris, or dust.

⚠ Warning:

When installing or moving the indoor or outdoor unit, use only the specified refrigerant (R410A) to charge the refrigerant lines. Do not mix it with any other refrigerant and do not allow air to remain in the lines. Air enclosed in the lines can cause pressure peaks resulting in a rupture and other hazards.

	RP35, 50	RP60-140/HRP71-125
Liquid pipe	ø6.35 thickness 0.8 mm	ø9.52 thickness 0.8 mm
Gas pipe	ø12.7 thickness 0.8 mm	ø15.88 thickness 1.0 mm

- Do not use pipes thinner than those specified above.

■ Connecting pipes (Figure 4.4.1)

- When commercially available copper pipes are used, wrap liquid and gas pipes with commercially available insulation materials (heat-resistant to 100 °C or more, thickness of 12 mm or more).
- Apply thin layer of refrigerant oil to pipe and joint seating surface before tightening flare nut.
- Use two wrenches to tighten piping connections.
- Use refrigerant piping insulation to insulate indoor unit connections.

ⓑ Flare nut tightening torque

Copper pipe O.D. (mm)	Flare nut O.D. (mm)	Tightening torque (N·m)
ø6.35	17	14 - 18
ø6.35	22	34 - 42
ø9.52	22	34 - 42
ø12.7	26	49 - 61
ø12.7	29	68 - 82
ø15.88	29	68 - 82
ø15.88	36	100 - 120

ⓒ Apply refrigerating machine oil over the entire flare seat surface.

ⓓ Use correct flare nuts matching the pipe size of the outdoor unit.

Ⓐ Flare cutting dimensions

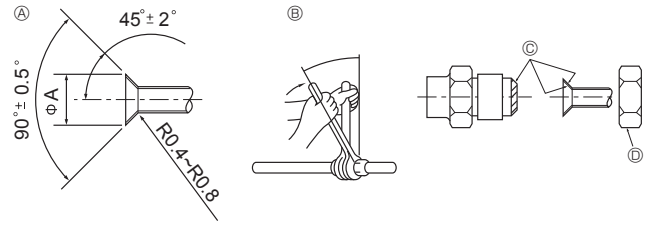

Ⓐ Flare cutting dimensions
ⓑ Flare nut tightening torque

<Figure 4.4.1>

Copper pipe O.D. (mm)	Flare dimensions øA dimensions (mm)
ø 6.35	8.7 - 9.1
ø9.52	12.8 - 13.2
ø12.7	16.2 - 16.6
ø15.88	19.3 - 19.7

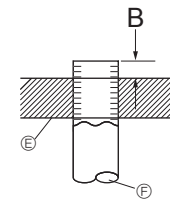

Ⓔ Die
Ⓕ Copper pipe

<Figure 4.4.2>

Copper pipe O.D. (mm)	B (mm)
	Flare tool for R410A Clutch type
ø6.35 (1/4")	1.0 - 1.5
ø9.52 (3/8")	1.0 - 1.5
ø12.7 (1/2")	1.0 - 1.5
ø15.88 (5/8")	1.0 - 1.5

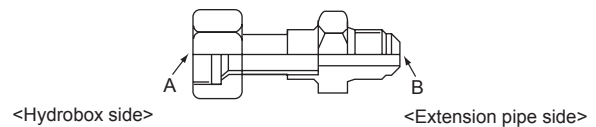

<Figure 4.4.3>

Match the outer diameter of the refrigerant pipe between the outdoor unit and hydrobox with that of the refrigerant pipe on the outdoor unit. If they do not match, connect the following adapter to the refrigerant pipe on the hydrobox.

Model name	Connected pipes diameter (mm)	Diameter A (mm)	Diameter B (mm)
PAC-SH50RJ-E	ø15.88 → ø12.7	ø15.88 (5/8 F)	ø12.7 (1/2 F)
PAC-SH30RJ-E	ø9.52 → ø6.35	ø9.52 (3/8 F)	ø6.35 (1/4 F)

4 Installation

4.5 Electrical Connection

All electrical work should be carried out by a suitably qualified technician. Failure to comply with this could lead to electrocution, fire, and death. It will also invalidate product warranty. All wiring should be undertaken fully in accordance with national wiring regulations.

Breaker abbreviation	Meaning
ECB1	Earth leakage breaker booster heater
TB1	Terminal bed 1

The hydrobox can be powered in two ways.

1. Power cable is run from the outdoor unit to the hydrobox.
2. Hydrobox has independent power source

Connections should be made to the terminals indicated in the following figures depending on the phase.

Booster heater should be connected independently to a dedicated power supply.

- Ⓐ Locally supplied wiring should be inserted through the chord/cable entries situated on the base of the hydrobox.
- Ⓑ Both cables should be secured using the cable tie provided and allow enough slack to enable the opening and closing of the electrical box.
- Ⓒ The cables should be inserted through the cable entries on the base of the electrical box.
- Ⓓ Run the cable for the booster heater up the right hand side of the electrical box and clamp in place. Connect the booster heater power cable to ECB1.
- Ⓔ Connect the outdoor unit - Hydrobox connecting cable to TB1.

- Make sure that ECB1 is ON.
- On completion of wiring ensure main controller cable is connected to the quick release connector.

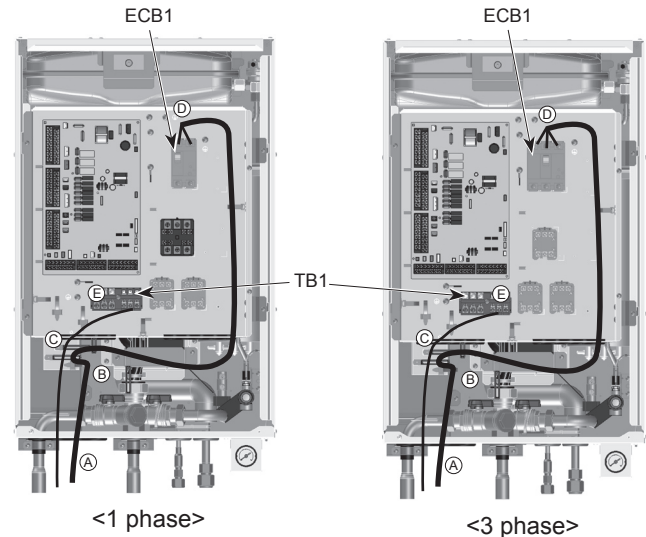

<Figure 4.5.1>

Hydrobox NOTICE

When the hydrobox leaves the factory, the main controller cable (Fig. 4.5.2) on the main unit is not connected to the controller's connector (Fig. 4.5.3) on the front panel.

After completing installation and wiring in the field, connect the main controller cable to the connector, then turn on the power.

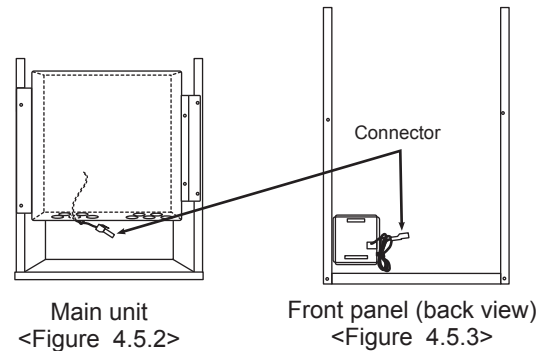

Main unit
<Figure 4.5.2>

Front panel (back view)
<Figure 4.5.3>

4 Installation

Option 1: Hydrobox powered via outdoor unit
<1 phase>

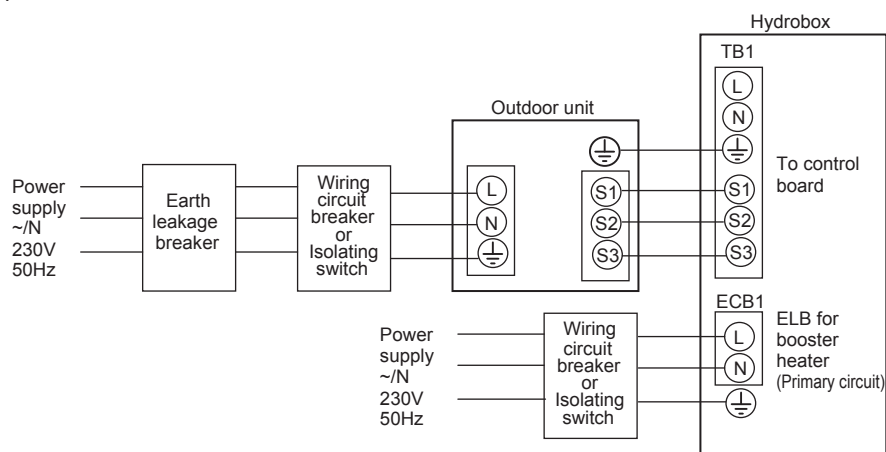

* Installer MUST affix label A that is included with the manuals near each wiring diagram for hydrobox and outdoor units.

<Figure 4.5.4>
Electrical connections 1 phase

Description	Power supply	Capacity (Indoor unit Ref.)	Breaker	Wiring
Booster heater (Primary circuit)	~/N 230 V 50 Hz	2 kW (EHPX-VM2A)	16 A *1	2.5 mm ²
		6 kW (EHSC-VM6A)	32 A *1	6.0 mm ²
Wiring No. x size (mm ²)	Hydrobox - Outdoor unit	*2	3 × 1.5 (polar)	
	Hydrobox - Outdoor unit earth	*2	1 × Min. 1.5	
Circuit rating	Hydrobox - Outdoor unit S1 - S2	*3	AC230V	
	Hydrobox - Outdoor unit S2 - S3	*3	DC24V	

*1. A breaker with at least 3.0 mm contact separation in each pole shall be provided. Use earth leakage breaker (NV). The breaker shall be provided to ensure disconnection of all active phase conductors of the supply.

*2. Max. 45 m
If 2.5 mm² used, Max. 50 m
If 2.5 mm² used and S3 separated, Max. 80 m

*3. The values given in the table above are not always measured against the ground value.

Notes: 1. Wiring size must comply with the applicable local and national codes.

2. Indoor unit/outdoor unit connecting cords shall not be lighter than polychloroprene sheathed flexible cord. (Design 60245 IEC 57)
Indoor unit power supply cords shall not be lighter than polychloroprene sheathed flexible cord. (Design 60227 IEC 53)

3. Install an earth longer than other cables.

4. The power supply MUST have sufficient capacity for each heater and ALL electrical loads. Insufficient power supply may result in chattering of load contactor(s).

4 Installation

<3 phase>

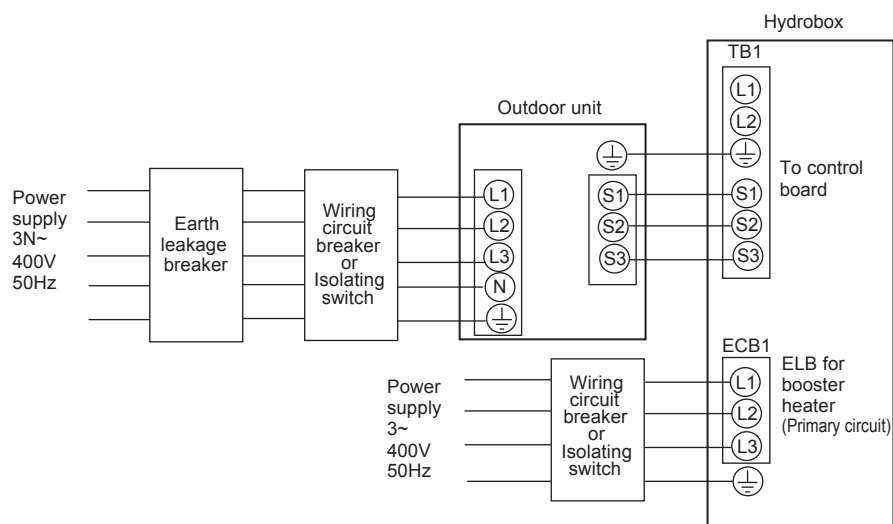

* Installer MUST affix label A that is included with the manuals near each wiring diagram for hydrobox and outdoor units.

<Figure 4.5.5>
Electrical connections 3 phase

Description	Power supply	Capacity (Indoor unit Ref.)	Breaker	Wiring
Booster heater (Primary circuit)	3~ 400V 50Hz	9 kW (EHSC-YM9A)	16 A *1	2.5 mm ²

Wiring No. x size (mm ²)	Hydrobox - Outdoor unit	*2	3 × 1.5 (polar)
	Hydrobox - Outdoor unit earth	*2	1 × Min. 1.5
Circuit rating	Hydrobox - Outdoor unit S1 - S2	*3	AC230V
	Hydrobox - Outdoor unit S2 - S3	*3	DC24V

*1. A breaker with at least 3.0 mm contact separation in each pole shall be provided. Use earth leakage breaker (NV).

The breaker shall be provided to ensure disconnection of all active phase conductors of the supply.

*2. Max. 45 m

If 2.5 mm² used, Max. 50 m

If 2.5 mm² used and S3 separated, Max. 80 m

*3. The values given in the table above are not always measured against the ground value.

- Notes:
1. Wiring size must comply with the applicable local and national codes.
 2. Indoor unit/outdoor unit connecting cords shall not be lighter than polychloroprene sheathed flexible cord. (Design 60245 IEC 57)
Indoor unit power supply cords shall not be lighter than polychloroprene sheathed flexible cord. (Design 60227 IEC 53)
 3. Install an earth longer than other cables.
 4. The power supply MUST have sufficient capacity for each heater and ALL electrical loads. Insufficient power supply may result in chattering of load contactor(s).

4 Installation

Option2: Hydrobox powered by independent source

If the hydrobox and outdoor units have separate power supplies, the following requirements MUST be carried out:

- Hydrobox electrical box connector connections changed (see Figure 4.5.6)
- Outdoor unit DIP switch settings changed to SW8-3 ON.
- Turn on the outdoor unit BEFORE the hydrobox.

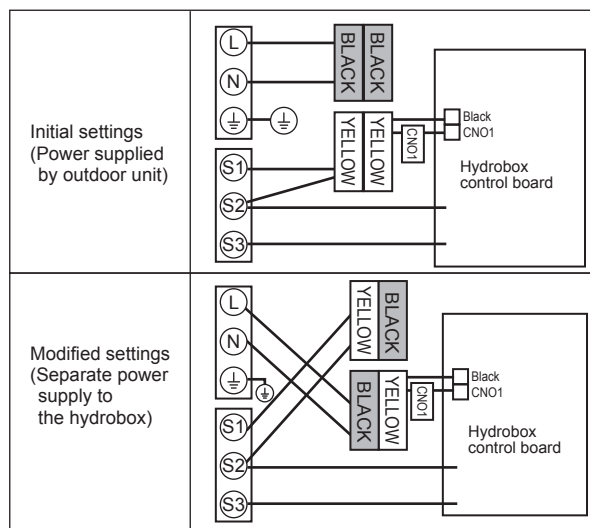

<Figure 4.5.6>

<1 phase>

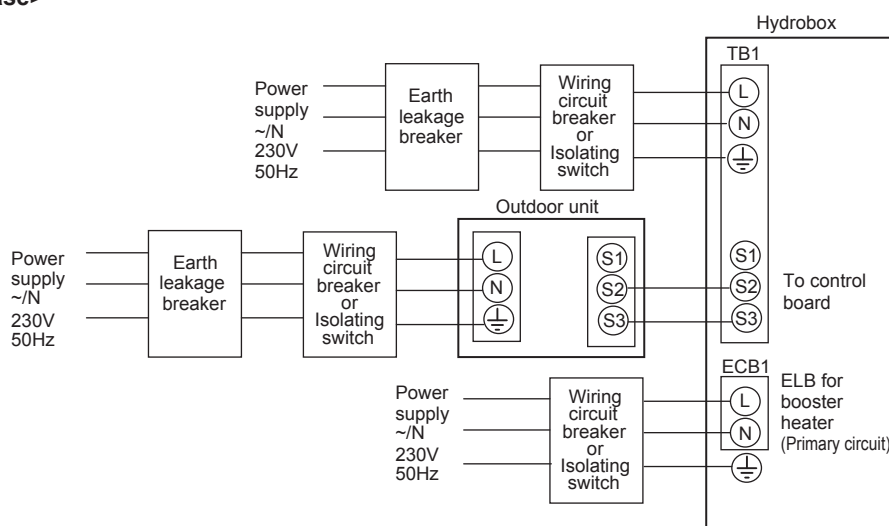

* Installer MUST affix label B that is included with the manuals near each wiring diagram for hydrobox and outdoor units.

<Figure 4.5.7>
Electrical connections 1 phase

Description	Power supply	Capacity (Indoor unit Ref.)	Breaker	Wiring
Booster heater (Primary circuit)	~N 230 V 50 Hz	2 kW (EHPX-VM2A)	16 A *1	2.5 mm ²
		6 kW (EHSC-VM6A)	32 A *1	6.0 mm ²

Hydrobox power supply		~N 230 V 50 Hz
Hydrobox input capacity Main switch (Breaker)		*1 16 A
Wiring No. x size (mm ²)	Hydrobox power supply	2 x Min. 1.5
	Hydrobox power supply earth	1 x Min. 1.5
	Hydrobox - Outdoor unit	*2 2 x Min. 0.3
	Hydrobox - Outdoor unit earth	—
Circuit rating	Hydrobox L - N	*3 AC230V
	Hydrobox - Outdoor unit S1 - S2	*3 —
	Hydrobox - Outdoor unit S2 - S3	*3 DC24V

*1. A breaker with at least 3.0 mm contact separation in each pole shall be provided. Use earth leakage breaker (NV). The breaker shall be provided to ensure disconnection of all active phase conductors of the supply.

*2. Max. 120 m

*3. The values given in the table above are not always measured against the ground value.

- Notes:**
1. Wiring size must comply with the applicable local and national codes.
 2. Indoor unit/outdoor unit connecting cords shall not be lighter than polychloroprene sheathed flexible cord. (Design 60245 IEC 57)
Indoor unit power supply cords shall not be lighter than polychloroprene sheathed flexible cord. (Design 60227 IEC 53)
 3. Install an earth longer than other cables.
 4. The power supply MUST have sufficient capacity for each heater and ALL electrical loads. Insufficient power supply may result in chattering of load contactor(s).

4 Installation

<3 phase>

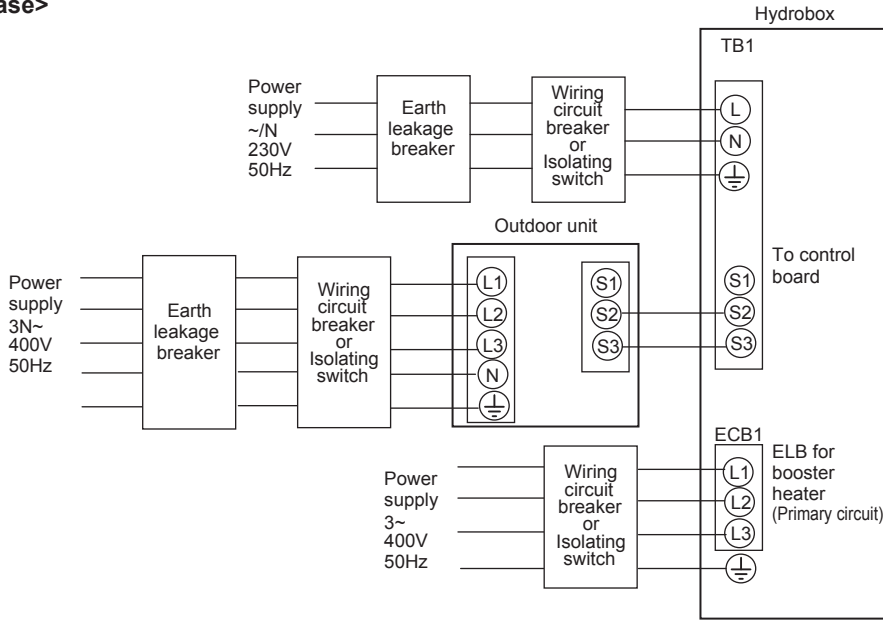

* Installer MUST affix label B that is included with the manuals near each wiring diagram for hydrobox and outdoor units.

<Figure 4.5.8>
Electrical connections 3 phase

Description	Power supply	Capacity (Indoor unit Ref.)	Breaker	Wiring
Booster heater (Primary circuit)	3~ 400V 50Hz	9 kW (EHSC-YM9A)	16 A *1	2.5 mm ²

Hydrobox power supply		~N 230 V 50 Hz
Hydrobox input capacity Main switch (Breaker)		*1 16 A
Wiring No. x size (mm ²)	Hydrobox power supply	2 x Min. 1.5
	Hydrobox power supply earth	1 x Min. 1.5
Circuit rating	Hydrobox - Outdoor unit	*2 2 x Min. 0.3
	Hydrobox - Outdoor unit earth	—
Circuit rating	Hydrobox L - N	*3 AC230V
	Hydrobox - Outdoor unit S1 - S2	*3 —
	Hydrobox - Outdoor unit S2 - S3	*3 DC24V

*1. A breaker with at least 3.0 mm contact separation in each pole shall be provided. Use earth leakage breaker (NV).
The breaker shall be provided to ensure disconnection of all active power (i.e. phase AND neutral) conductors of the supply.

*2. Max. 120 m

*3. The values given in the table above are not always measured against the ground value.

- Notes:**
1. Wiring size must comply with the applicable local and national codes.
 2. Indoor unit/outdoor unit connecting cords shall not be lighter than polychloroprene sheathed flexible cord. (Design 60245 IEC 57)
Indoor unit power supply cords shall not be lighter than polychloroprene sheathed flexible cord. (Design 60227 IEC 53)
 3. Install an earth longer than other cables.
 4. The power supply MUST have sufficient capacity for each heater and ALL electrical loads. Insufficient power supply may result in chattering of load contactor(s).

5 System Set Up

5.1 Dip Switch Functions

Located on the FTC3 printed circuit board are 4 sets of small white switches known as Dip switches. The Dip switch number is printed on the circuit board next to the relevant switches. The word ON is printed on the circuit board and on the Dip switch block itself. To move the switch you will need to use a pin or the corner of a thin metal ruler or similar.

Dip switch settings are listed below in Table 5.1.1.

Note: Electrically ISOLATE BEFORE doing any such work.

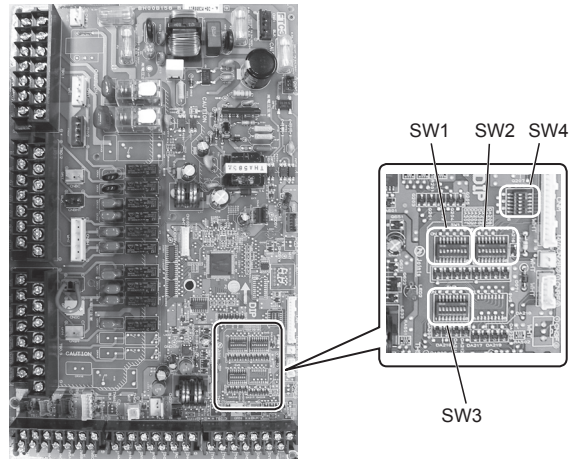

<Figure 5.1.1>

Dip switch		Function	OFF	ON	Default (Indoor unit Ref.)
SW1	SW1-1	—	—	—	OFF
	SW1-2	Heat pump maximum outlet water temperature	55 °C	60 °C	OFF: EHSC (*1) ON : EHPX
	SW1-3	DHW tank	WITHOUT DHW tank	WITH DHW tank	OFF
	SW1-4	Immersion heater	WITHOUT immersion heater	WITH immersion heater	OFF
	SW1-5	Booster heater	WITHOUT booster heater	WITH booster heater	ON
	SW1-6	Booster heater function	For heating only	For heating and DHW	OFF
	SW1-7	Outdoor unit type	Split type	Packaged type	OFF: EHSC ON : EHPX
	SW1-8	Wireless remote controller	WITHOUT wireless remote controller	WITH wireless remote controller	OFF
SW2	SW2-1	Room thermostat input (IN1) logic change	Operation stop at thermostat short	Operation stop at thermostat open	OFF
	SW2-2	Flow switch input (IN2) logic change	Failure detection at short	Failure detection at open	ON
	SW2-3	Booster heater capacity restriction	Inactive	Active	OFF: EHSC ON : EHPX-VM2A
	SW2-4	—	—	—	OFF
	SW2-5	Automatic switch to backup heater only operation (When outdoor unit stops by error)	Inactive	Active (*3)	OFF
	SW2-6	—	—	—	OFF
	SW2-7	—	—	—	OFF
	SW2-8	—	—	—	OFF
SW3	SW3-1	—	—	—	OFF
	SW3-2	—	—	—	OFF
	SW3-3	—	—	—	OFF
	SW3-4~8	—	—	—	OFF
SW4	SW4-1~4	—	—	—	OFF
	SW4-5	Emergency mode (Heater only operation)	Normal	Emergency mode (Heater only operation) (To be activated only when powered ON)	OFF (*2)
	SW4-6	—	—	—	OFF

<Table 5.1.1>

- Notes:
- *1. For packaged model system, the max outlet water temperature is always 60°C so default Dip switch SW1-2 is ON.
For split model system, the max outlet water temperature is usually 55°C except in the case of PUHZ-HRP outdoor model where the max outlet water temperature is 60°C and DIP switch SW1-2 should be changed to ON.
 - *2. If emergency mode is no longer required, please turn off both outdoor and indoor unit power supply before returning SW4-5 to OFF position.
 - *3. For safety reasons, this function is not available for certain errors. (System operation must be stopped and only pump keeps running.)
External output (OUT11) will be available.

5 System Set Up

5.2 Connecting external input/output

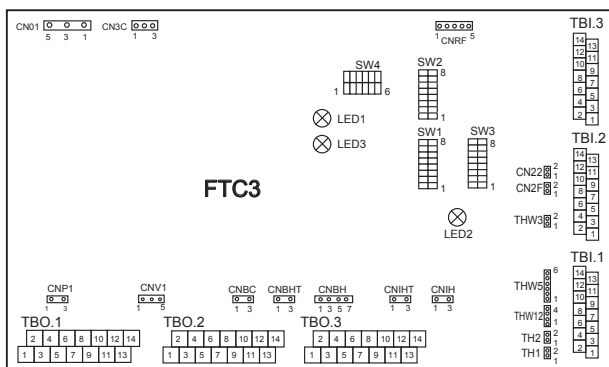

<Figure 5.2.1>

When connecting the terminals use the ring terminals and also insulate the cables of adjoining terminals when wiring to terminal block.

External input

Name	Terminal block	Connector	Item	OFF (Open)	ON (Short)
IN1	TBI.2 5-6	—	Room thermostat input	Refer to SW2-1 (Page 22)	
IN2	TBI.2 7-8	CN2F	Flow switch input	Refer to SW2-2 (Page 22)	
IN3	—	—	—	—	—
IN4	TBI.2 13-14	—	Heat source OFF	Normal	Heat source OFF
IN5	TBI.3 7-8	—	Outdoor thermostat input (*1)	Standard operation	Heater operation

*1. If using outdoor thermostat for controlling operation of heaters, the lifetime of the heaters and related parts may be reduced.

Wiring specification and field supply parts

Item	Name	Model and specifications
External input function	External input signal wire	Use sheathed vinyl coated cord or cable. Max. 10 m Wire type: CV, CVS or equivalent Wire size: Stranded wire 0.5 mm ² to 1.25 mm ² Solid wire: ø 0.65 mm to ø 1.2 mm
	Switch	Non-voltage "a" contact signals Remote switch: minimum applicable load DC 12V, 1mA

External output

Name	Terminal block	Connector	Item	OFF	ON	Signal/Max current
OUT1	TBO.1 1-2	CNP1	Water circulation pump1(AC) output (Space heating & DHW)	OFF	ON	AC230V 1.0A Max
OUT2	TBO.1 3-4	—	Water circulation pump2(AC) output (Space heating ONLY)	OFF	ON	AC230V 1.0A Max
OUT3	—	—	—	—	—	—
OUT4	TBO.1 7-9	CNV1	3-way valve (2-way valve1) output	Heating	DHW	AC230V 0.1A Max
OUT5	—	—	—	—	—	—
OUT6	TBO.2 5-6	CNBH 1-3	Booster heater1 output	OFF	ON	AC230V 0.5A Max (Relay)
OUT7	TBO.2 7-8	CNBH 5-7	Booster heater2 output	OFF	ON	AC230V 0.5A Max (Relay)
OUT8	TBO.2 9-10	—	Booster heater2+ output	OFF	ON	AC230V 0.5A Max (Relay)
OUT9	TBO.3 5-6	CNIH	Immersion heater output	OFF	ON	AC230V 0.5A Max (Relay)
OUT10	—	—	—	—	—	—
OUT11	TBO.2 11-12	—	Error output	Normal	Error	AC230V 0.5A Max
OUT12	TBO.2 13-14	—	Defrost output	Normal	Defrost	AC230V 0.5A Max
OUT13	TBO.3 7-8	—	2-way valve 2 output	DHW	Heating	AC230V 0.1A Max

Do not connect to the terminals that are indicated as "—" in the "Terminal block" field.

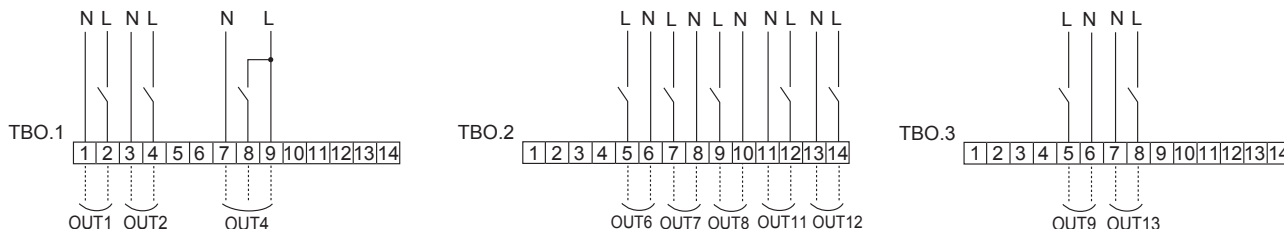

Wiring specification and field supply parts

Item	Name	Model and specifications
External output function	External output signal wire	Use sheathed vinyl coated cord or cable. Max. 50 m Wire type: CV, CVS or equivalent Wire size: Stranded wire 0.5 mm ² to 1.25 mm ² Solid wire: ø 0.65 mm to ø 1.2 mm
	Relay, etc.	AC 230V signal 0.5 A or less

Notes:

- When connecting an auxiliary pump with an electric current of ≥1A or multiple auxiliary pumps with TOTAL current of ≥1A, use (a) relay(s).
- Do NOT connect pumps to both TBO.1 1-2 and CNP1 (see fig 5.2.1) at the same time.

<When connecting field supply optional pumps please note the following>

Option 1. (Power supply from outdoor unit)

TOTAL current requirement of the pumps MUST be ≤3A (otherwise, fuse on the outdoor unit PCB will blow).

Option 2. (Independent power supply (i.e. from the hydrobox unit itself))

TOTAL current of the pump(s) MUST be ≤2A (otherwise, fuse on the hydrobox (FTC3) PCB will blow). The total current allowed for parts except pumps is 3A.

To avoid the fuses blowing please avoid having a total current of 3A or greater.

5 System Set Up

Installation procedure for DHW tank

Note:

- Be aware that the respective DHW operations are greatly effected by the selections of the components such as tank, immersion heater, or the like.
- Follow your local regulations to perform system configuration.

1. To enable switching of the water circulation circuit between the DHW mode and the heating mode, install a 3-way valve (field supply). The 3-way valve and the DHW tank should be positioned as shown in the system diagram on the page 10, figs 3.5/3.6 as applicable.
The use of two 2-way valves can perform the same function as a 3-way valve.
2. Install the enclosed thermistor THW5B on the DHW tank.
It is recommended to position the thermistor at the mid point of the DHW tank capacity. Insulate thermistor from ambient air. Especially for double (insulated) tank, thermistor should be attached to the inner side (to detect the water temperature).
3. Connect the thermistor lead to the THW5 connector on the FTC3.
If the thermistor lead is too long it can be cut to the required length and then connected directly to the THW5B labeled terminals on the terminal block TBI.1.
4. The external output terminals for the 3-way valve is TBO.1-7, 8, 9 (OUT4).
The TBO.1-7, 8, 9 terminals on the FTC3 are shown in the wiring diagram on the right.
Choose the terminals that the 3-way valve is connected to between TBO.1-7, 8, or TBO. 1- 7, 8, 9, according to the rated voltage.
When the rated current of the 3-way valve exceeds 0.1A, be sure to use a relay with maximum voltage and current ratings of 230V AC / 0.1A when connecting to the FTC3. Do not directly connect the 3-way valve cable to the FTC3.
Connect the relay cable to the TBO. 1-7, 8 terminals. For systems using 2-way valves instead of a 3-way valve please read the following;

Specification of 2-way valve (field supply)

- Power supply: 230V AC
- Current: 0.1A Max (**If over 0.1A you must use a relay**)
- Type: Normally closed

	Installation position	Electrical connection terminal block	Output signal		
			Heating	DHW	System OFF
2-way valve1	DHW	TBO.1 7-8	OFF (closed)	ON (open)	OFF (closed)
2-way valve2	Heating	TBO.3 7-8	ON (open)	OFF (closed)	OFF (closed)

Note: Should the 2-way valve become blocked the water circulation will stop.

A by-pass valve or circuit should be installed between pump and 2-way valve for safety.

The TBO.3-7, 8 terminals on the FTC3 are shown in the wiring diagram on the right.

The 2-way valve (field supply) should be installed according to the instructions supplied with it. Follow 2-way valve maker's instructions as to whether to connect an earth cable or not.

- For the 2-way valve, choose the one that slowly opens and shuts off to prevent water hammer sound.
- Choose the 2-way valve equipped with manual override, which is necessary for topping up or draining of water.

5. Turn the DIP SW1-3 on the FTC3 to ON.

6. When using the immersion heater (field supply), connect a contact relay cable for the immersion heater to TBO.3-5, 6 (OUT9), and turn the Dip SW1-4 to ON. Do NOT directly connect the power cable to the FTC3.

Note:

- When an immersion heater is installed, select appropriate breaker capacity and a cable with appropriate diameter on the basis of heater output.
- When wiring an immersion heater in the field, always install an earth leakage breaker to prevent accidental electric shock.

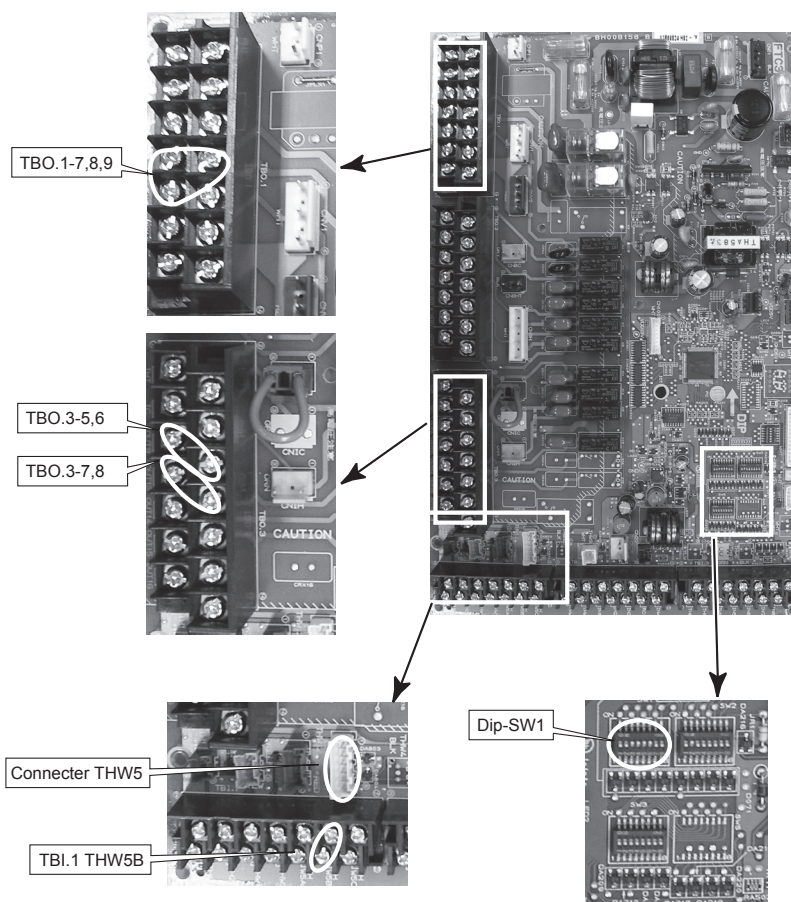

- ⚠ WARNING: When connecting DHW tank**
- (1) When installing an immersion heater, use an overheat protection thermostat.
 - (2) Connect a pressure relief valve on the sanitary water side.
 - (3) Attach the enclosed thermistor THW5B.
 - (4) Always use earth leakage breaker when connecting immersion heater.

5 System Set Up

Recommended DHW system

Where system involves a DHW cylinder:

DHW tank	Immersion heater	Booster heater	BH function	System diagram	Thermistor
Present	Absent	Present	For space heating and DHW	<p>The diagram shows a DHW tank with a booster heater. A hydrobox contains the booster heater. A 3-way valve is located between the hydrobox and the heat emitter. Thermistors THW1, THW2, THW3, and THW5B are positioned at various points in the system.</p>	THW1: Flow water temp. THW2: Return water temp. THW3: Booster heater temp. THW5B: Tank water temp.
Present	Present	Present	For space heating and DHW	<p>The diagram shows a DHW tank with an immersion heater and a booster heater. A hydrobox contains the booster heater. A 3-way valve is located between the hydrobox and the heat emitter. Thermistors THW1, THW2, THW3, and THW5B are positioned at various points in the system.</p>	THW1: Flow water temp. THW2: Return water temp. THW3: Booster heater temp. THW5B: Tank water temp.

*The use of two 2-way valves can perform same function as a 3-way valve.

5 System Set Up

5.3 Remote Controller Options

The hydrobox comes factory fitted with a main controller. This incorporates a thermistor for temperature monitoring and a graphical user interface to enable set-up, view current status and input scheduling functions. The main controller is also used for servicing purposes. (This function is accessed via the password protected service menus.)

To provide the best efficiency Mitsubishi Electric recommends using automatic adaptation function based on room temperature. To use this function a room thermistor needs to be present in a main living area. This can be done in a number of ways the most convenient are detailed below.

Refer to heating section of this manual for instructions on how to set compensation curve, flow temp or room temp (Auto adaptation).

For instructions on how to set the thermistor input for the FTC3 please refer to initial settings section.

The factory setting for space heating is room temp (auto adaptation). If there is no room sensor present in the system, this setting must be changed to either compensation curve mode or flow temp mode.

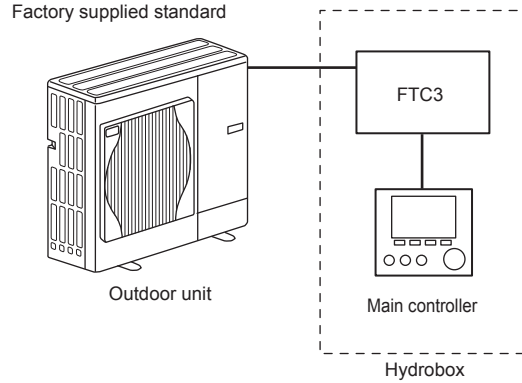

Control option A

This option features the main controller and the Mitsubishi Electric wireless remote controller. The wireless remote controller is used to monitor room temperature and can be used to make changes to the space heating settings, boost DHW(*) and switch to holiday mode without having to directly use the main controller.

If more than one wireless remote controller is used, the most recent temperature settings entered will be used regardless of which controller is used to enter the settings.

The wireless receiver must be connected to the FTC3 as detailed in the wireless controller instruction manual.

DIP SW1-8 should be ON. Before operation wireless controller should be configured to transmit and receive data as detailed in the wireless controller installation manual.

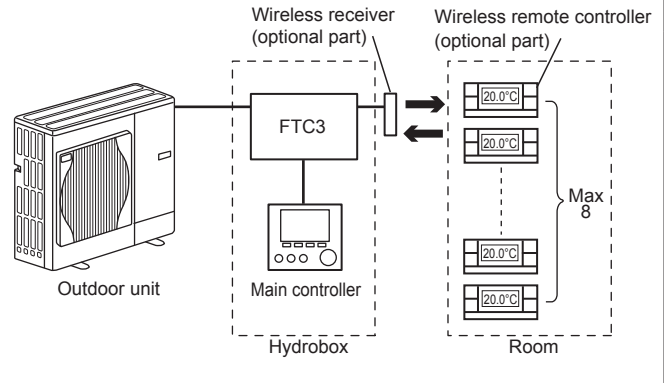

Control option B

This option features the main controller and the Mitsubishi Electric thermistor wired to the FTC3. The thermistor is used to monitor room temperature but can not make any changes in control operation. Any changes to DHW(*) must be made using main controller mounted on the hydrobox.

The thermistor is wired to the FTC3 using TH1 terminal on the terminal block TBI.1. Only 1 room temperature thermistor can be connected to the FTC3 at any one time.

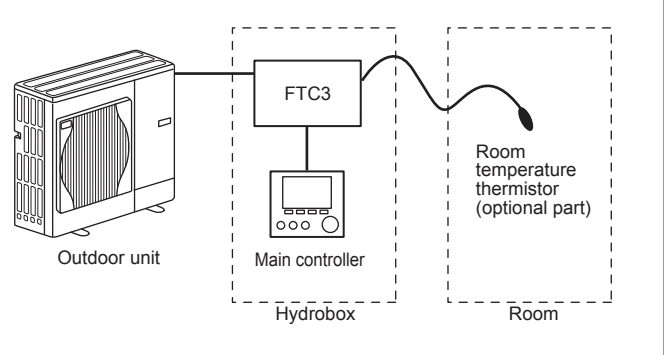

Control option C

This option features the main controller being removed from the hydrobox and situated in a different room. All features of the main controller are still available and the in-built thermistor can be used for monitoring the temperature of the room in which it is installed for Auto Adaptation function.

The main controller and the FTC3 are connected by a 2 core, 0.3 mm², non polar cable (field supply) maximum length of 500 m.

If using the sensor in the main controller it should be detached from hydrobox. Otherwise it will detect the temperature of the hydrobox instead of room temperature. This will influence the output of the space heating.

Mitsubishi Electric main control cover blank accessory should be used to fill the resultant gap on the hydrobox front panel left by the removal of the control panel.

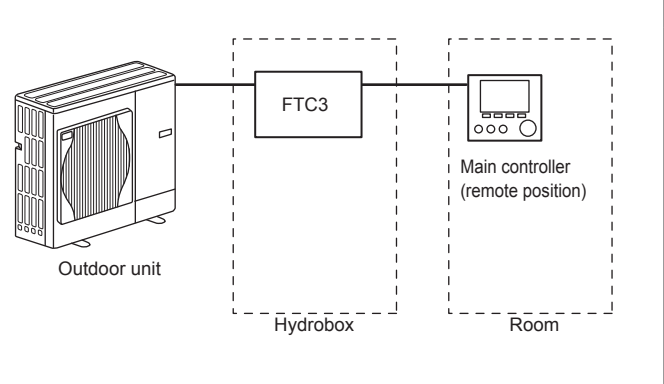

Control option D (Flow temp. or compensation curve only)

This option features the main controller and locally supplied thermostat wired to the FTC3. The thermostat is used to set the upper limit of space heating. Any changes to DHW(*) must be made using main controller mounted on the hydrobox.

The thermostat is wired to the FTC3 using IN1 terminal on the terminal block TBI.2. Only 1 thermostat can be connected to the FTC3 at any one time.

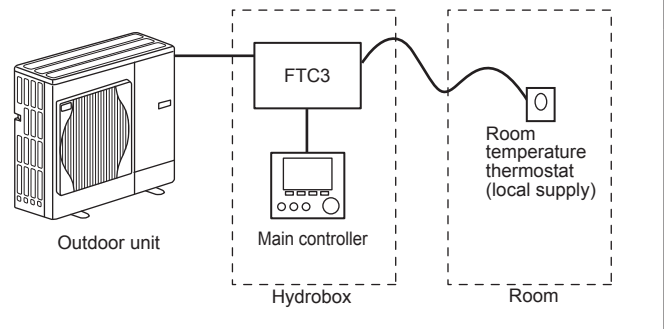

(*) If applicable

5 System Set Up

Remote Installation of Main Controller

The following instructions are related to a system controlled as in Control option C.

<Accessory>

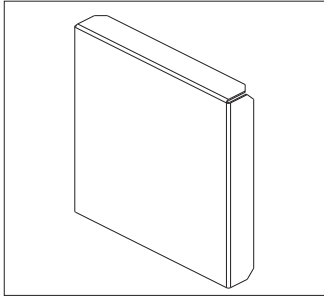

Main controller cover

<Removing the main controller from the hydrobox>

1. Open front panel of hydrobox.
2. Remove the four screws from the metal back plate of main controller using a screwdriver.
3. Untwist wire clip and lift off the metal back plate.
4. Gently pull apart the clips holding the main controller in place. Be careful not to use too much force as this may break the holding clips.
5. Lift out the main controller from the front panel of the hydrobox.

After removing the main controller, fill the resulting hole using the main controller cover.

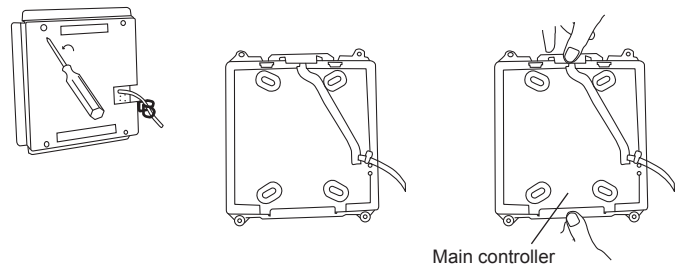

<Figure 5.3.1>
Removing main controller

6. Separate the back and front panel using a flat head screwdriver as shown in Figure 5.3.2.

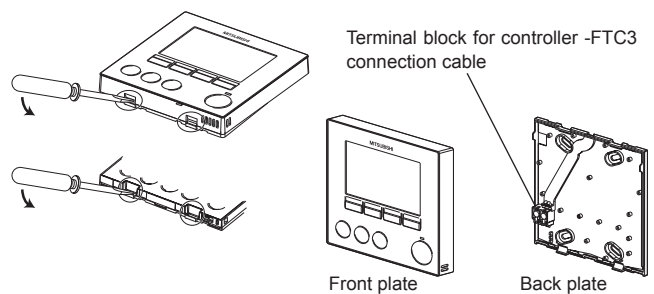

<Figure 5.3.2>
Opening the main controller

7. Fix the 2 core cable from the FTC3 into the terminal. Ensure the wires make good contact and are securely screwed into the terminal block.
8. The inner core wires should not be visible from the outside of the back plate.
9. The sheathed cable should be pressed into the sunken channel so it is flush with the base plate.
10. Once the connection cable is in place screw the back plate to the wall using screws (field supply) suitable for use on the chosen wall.
11. Finally replace the front cover plate.

Note:

Wiring for main controller cable shall be (5cm or more) apart from power source wiring so that it is not influenced by electrical noise from power source wiring. (Do NOT insert main controller cable and power source wiring in the same conduit.)

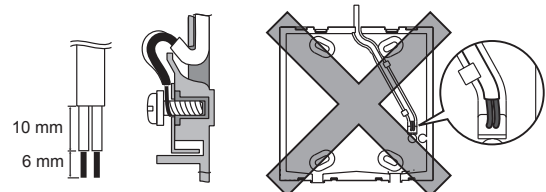

<Figure 5.3.3>
Securing the connection cable

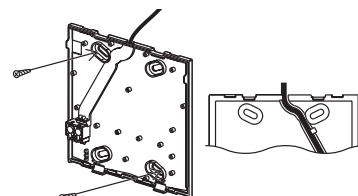

<Figure 5.3.4>
Securing the base plate to the wall

5 System Set Up

5.4 Main Controller

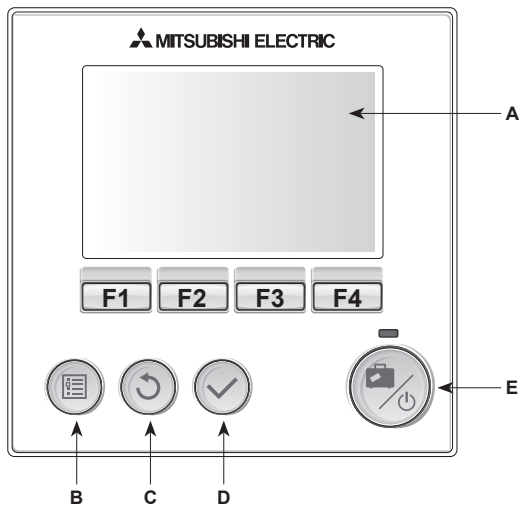

<Main controller parts>

Letter	Name	Function
A	Screen	Screen in which all information is displayed
B	Menu	Access to system settings for initial set up and modifications.
C	Back	Return to previous menu.
D	Confirm	Used to select or save. (Enter key)
E	Power/Holiday	If system is switched off pressing once will turn system on. Pressing again when system is switched on will enable Holiday Mode. Holding the button down for 3 secs will turn the system off. (*1)
F1-4	Function keys	Used to scroll through menu and adjust settings. Function is determined by the menu screen visible on screen A.

*1

When the system is switched off or the power supply is disconnected, the water circuit protection functions (e.g. freeze protection stat. function) will NOT operate. Please beware that without these safety functions enabled the water circuit is exposed to risk and may, potentially, be damaged.

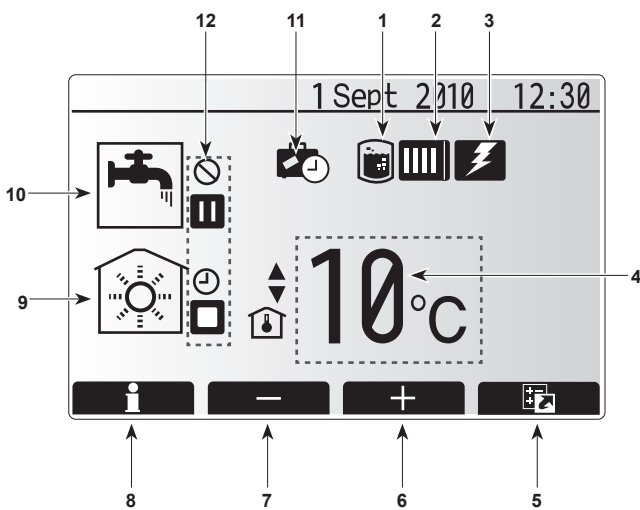

<Main screen icons>

	Icon	Description
1	Legionella prevention icon	When this icon is displayed 'Legionella Prevention mode' is active (if DHW tank in system).
2	Heat pump icon	When this icon is displayed the 'Heat pump' is in use.
3	Electric heater icon	When this icon is displayed the 'Electric heaters' are in use.
4	Target temperature icons	Target flow temperature Target room temperature Compensation curve
5	OPTION icon	Pressing the function button below this icon will display the quick view menu.
6	+	Increase desired temperature.
7	-	Decrease desired temperature.
8	Information icon	Pressing the function button below this icon displays the information screen.
9	Space heating mode icon	Heating mode
10	DHW mode icon	Normal or ECO mode displayed (if DHW tank in system)
11	Holiday mode icon	When this icon is displayed 'Holiday mode' time is set.
12	Timer icon	Timer
	Prohibited icon	Prohibited
	Stand-by icon	Stand-by
	Stop icon	Stop
	Operating icon	Operating

5 System Set Up

<Main Controller Menu Tree>

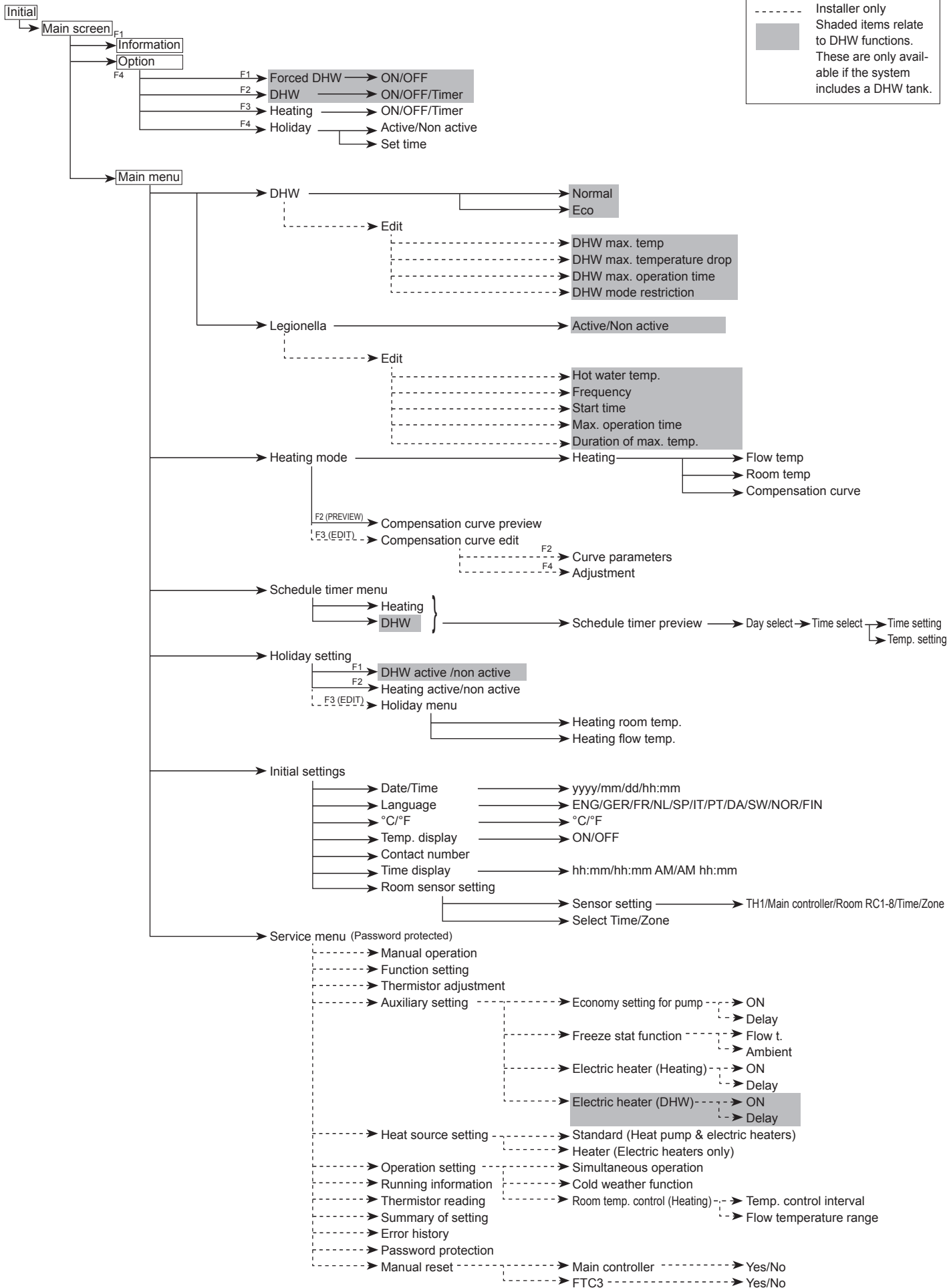

5 System Set Up

Setting the Main Controller

After the power has been connected to the outdoor unit and hydrobox (See chapter 4.5) the initial system settings can be entered via the main controller.

1. Power supply

- i. Check all breakers and other safety devices are correctly installed and turn on power to the system.
- ii. Main controller will automatically start up.
Wait approximately 6 mins whilst the control menus load.

2. Controller settings

When the controller is ready a blank screen with a line running across the top will be displayed.

- i. Press button E (Power)
If this is the first time the controller has been switched on you will automatically be directed to the Initial settings menu.
- * When the system is powered off, freeze protection stat. function is disabled/not performed.

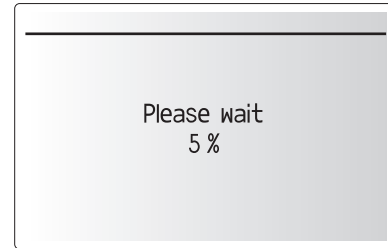

Initial Settings

From the initial settings menu the installer can set the language, date/time, temperature unit (°C/°F), emergency contact number, room sensor setting, and display options.

1. Use buttons F1 and F2 to move scroll through the menu list. When the title is highlighted press CONFIRM to edit.
2. Use function buttons appropriate to edit each setting then press CONFIRM to save the setting.
3. For room sensor setting it is important to choose the correct room sensor depending on which heating mode the system will operate in.

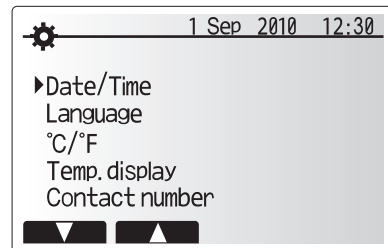

Control option (p26)	Corresponding initial settings room sensor
A	Room RC1-8 (only 1 can be selected)
B	TH1
C	Main controller
D	N/A (Option D uses a thermostat with off/on signal only, actual room/space temperature is not detected by FTC3)

NOTE

If you wish to operate in time/zone mode please select this from the room sensor setting menu then edit the schedule under 'Select Time/Zone' to reflect which room sensor you want operational for the given time period.

Once the controller initial settings are complete, settings for the main modes can be entered. To return to the main settings menu screen from the initial settings screen, press the BACK button.

Main Settings Menu

The main settings menu can be accessed by pressing the MENU button. To reduce the risk of untrained end users altering the settings accidentally **there are two access levels** to the main settings; and the service section menu is password protected.

User Level – Short press

If the MENU button is pressed once for a short time the main settings will be displayed but without the edit function. This will enable the user to view current settings but **NOT** change the parameters.

Installer Level – Long press

If the MENU button is pressed down for 3 secs the main settings will be displayed with all functionality available.

The following items can be viewed and/or edited (dependent on access level).

- Domestic Hot water (DHW) (only relevant for systems with the DHW cylinder)
- Heating
- Schedule timer
- Holiday mode
- Initial settings
- Service (Password protected)

Use the F2 and F3 buttons to move between the icons. The highlighted icon will appear as a larger version in the centre of the screen. Press CONFIRM to select and edit the highlighted mode.

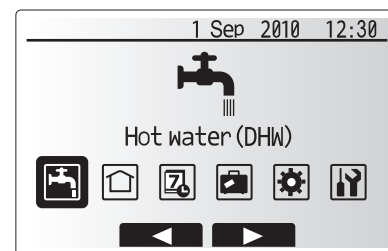

Icon	Description
	Hot water (DHW)
	Heating
	Schedule timer
	Holiday mode
	Initial setting
	Service

5 System Set Up

Mode 1 - Domestic Hot Water (DHW)/Legionella Prevention (only relevant if 3rd party DHW tank present)

The domestic hot water and legionella prevention menus control the operation of domestic hot water tank heat ups.

<DHW mode settings>

1. Highlight the hot water icon and press CONFIRM.
2. Use button F1 to switch between Normal and ECO heating modes.
3. To edit the mode press F2 to display the HOT WATER (DHW) SETTING menu.
4. Use F2 and F3 keys to scroll through the menu selecting each component in turn by pressing CONFIRM. See the table below for description of each setting.
5. Enter the desired number using the function keys and press CONFIRM.

Menu subtitle	Function	Range	Unit	Default value
DHW max. temp	Desired temperature of stored hot water	40–60	°C	50
DHW max. temperature drop	Difference in temperature between DHW max. temp and the temperature at which DHW mode re-starts	5–30	°C	10
DHW max. operation time	Max time allowed for stored water heating DHW mode	30–120	min	60
DHW mode restriction	The time period after DHW mode when space heating has priority over DHW mode temporarily preventing further stored water heating (Only when DHW max. operation time has passed.)	30–120	min	30

<Explanation of DHW operation>

- When the tank temperature drops from "DHW max. temp" by more than the "DHW max. temperature drop" (set by installer), DHW mode operates and the flow from the primary heating circuit is diverted to heat the water in the storage tank.
- When the temperature of the stored water reaches the 'DHW max. temp.' set by the installer or if the 'DHW max. operation time' set by the installer is exceeded, DHW mode ceases to operate.
- Whilst DHW mode is in operation primary hot water is not directed to the space heating circuit.
- Directly after DHW max. operation time 'DHW mode restriction' will routinely operate. The duration of this feature is set by the installer and during its operation DHW mode can not (normally) be reactivated, allowing time for the system to deliver primary hot water to the space heating if required.
- After normal 'DHW mode restriction' operation the DHW mode can operate again and tank heating will continue according to system demand.

<Eco mode>

DHW mode can run in either 'Normal' or 'Eco' mode. Normal mode will heat the cylinder more quickly using the full power of the heat pump. Eco mode takes a little longer to heat the cylinder but the energy used is reduced. This is because heat pump operation is restricted using signals from the FTC3 based on measured cylinder water temperature.

Note:

The actual energy saved in Eco mode will vary according to outdoor temperature.

Return to the DHW/legionella prevention menu.

Legionella Prevention Mode settings (LP mode)

1. Use button F3 to chose legionella mode active YES/NO.
2. Use button F4 to edit the legionella function.
3. Use F2 and F3 keys to scroll through the menu selecting each subtitle in turn by pressing CONFIRM. See the table below for description of each setting.
4. Enter the desired number using the function keys and press CONFIRM.

During Legionella Prevention Mode the temperature of the stored water is increased above 60°C to inhibit legionella bacterium growth. It is strongly recommended that this is done at regular intervals. Please check local regulations for the recommended frequency of heat ups.

Note: When failures occur on the hydrobox, the LP mode may not function normally.

Menu subtitle	Function	Range	Unit	Default value
Legionella hot water temp.	Desired temp of stored hot water	60–70	°C	65
Frequency	Time between LP mode tank heat ups	1–30	day	15
Start time	Time when LP mode will begin	0:00–23:00	-	03:00
Max. operation time	Maximum time allowed for LP mode tank heat	1–5	hour	3
Duration of max. temp.	The time period after LP mode max. water temp has been reached	1–120	min	30

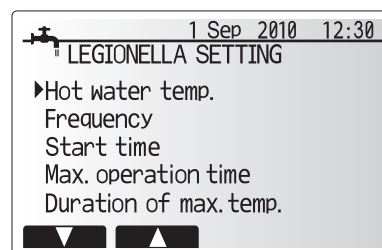
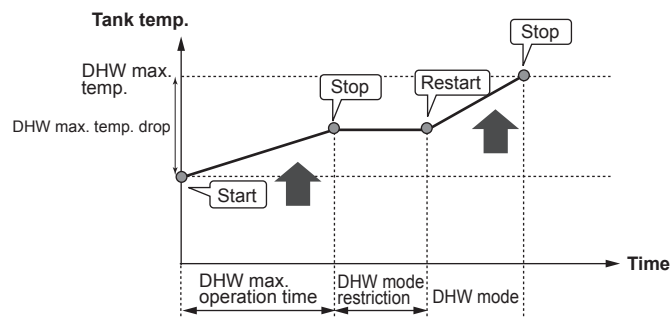
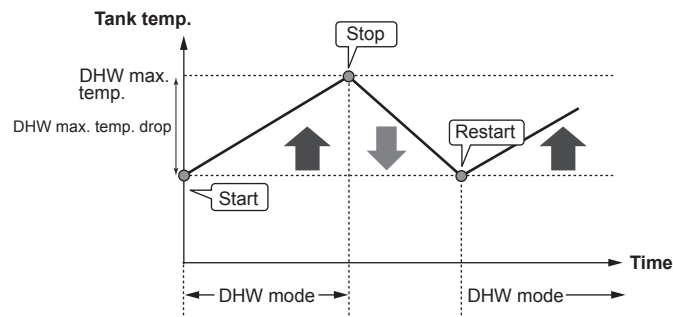
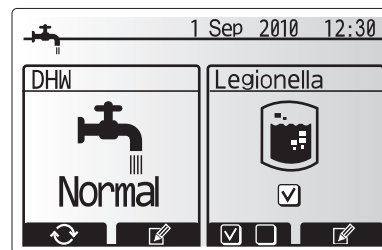

5 System Set Up

<Explanation of Legionella Prevention Mode operation>

- At the time entered by the installer 'Start time' flow of useful heat from the system is diverted to heat the water in the storage tank.
- When the temperature of the stored water exceeds the 'Hot Water temp.' set by the installer (above 65°C), primary circuit water is no longer diverted to heat the tank.
- Whilst LP mode is in operation hot water is not directed to the space heating circuit.
- Directly after LP mode operation 'Duration of max. temp' will operate. The duration of this feature is set by the installer and during its operation stored water temperature will be monitored.
- If stored water temperature should drop to LP restart temp, LP mode will restart and water flow from the system will be directed to boost the tank temperature. Once the set time for Duration of Max. temp. has passed LP mode will not recur for the set interval (set by installer).
- It is the responsibility of the installer to ensure the settings for legionella prevention are compliant with local and national guidelines.

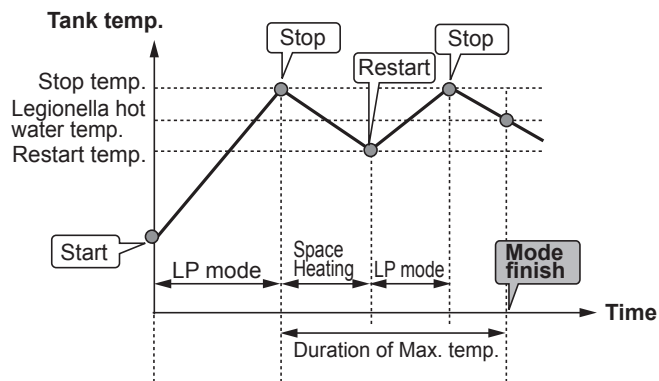

(LP mode : Legionella Prevention Mode)

Please note that LP mode uses the assistance of electric heaters (if present) to supplement the energy input of the heat pump. Heating water for long periods of time is not efficient and will increase running costs. The installer should give careful consideration to the necessity of legionella prevention treatment whilst not wasting energy by heating the stored water for excessive time periods. The end user should understand the importance of this feature. **ALWAYS COMPLY WITH LOCAL AND NATIONAL GUIDANCE FOR YOUR COUNTRY REGARDING LEGIONELLA PREVENTION.**

Forced DHW

The forced DHW function is used to force the system to operate in DHW mode. In normal operation the water in the DHW tank will be heated either to the set temperature or for the maximum DHW time, whichever occurs first. However should there be a high demand for hot water 'Forced DHW' function can be used to prevent the system from routinely switching to space heating and continue to provide heating for DHW tank.

Forced DHW mode is activated by pressing button F1 when the 'Option Screen' is displayed. Following operation, the system will automatically return to normal operation.

■ Mode 2 - Heating

The heating menu deals with space heating typically using either a radiator or under-floor system depending on the installation.

From the main settings menu

1. Use F1 and F2 buttons to highlight heating icon then press CONFIRM.
2. The heating menu will be displayed.
3. To select the sub-menus press the function button below the icon required. E.g. for MODE change press F1

Heating

1. Under this sub-menu the mode of heating is selected.
2. For HEATING choose between
 - Flow temperature (🔥)
 - Room temperature (🏠)
 - Compensation curve (📈)
3. To choose between the different modes for heating, highlight the mode preferred and press select.
4. Press the BACK button to return to the heating menu.

If compensation curve mode was selected as the heating mode please read the following instructions.

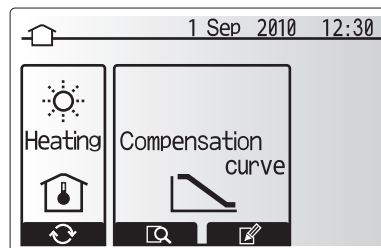

5 System Set Up

<Compensation curve setting (space heating)>

1. From the heating menu select edit using the F3 function button.
2. The compensation curve setting screen will be displayed.
3. Press F2 to alter the Hi parameter (when flow temp is maximum and outdoor temp is minimum).
4. Press F3 to alter the Lo parameter (when flow temp is minimum and outdoor temp is maximum).
5. Press F4 to add an extra point (adjust).

Pressing F2-4 will cause the relevant edit screen to be displayed. Editing Lo and Hi parameters is done in the same way; please see the following for more detailed explanation of parameter editing.

In the parameter (Lo/Hi) edit screen the flow temperature and outdoor temperature for the compensation curve graph can be set and altered for the 2 extremes of Hi and Lo.

1. Press F1 and F2 to change the flow temperature (y-axis of compensation curve).
2. Pressing F1 will raise the desired flow temperature for the set outdoor temperature.
3. Pressing F2 will lower the desired flow temperature for the set outdoor temperature.
4. Press F3 and F4 to change the outdoor temperature (x-axis of compensation curve).
5. Pressing F3 will lower the outdoor temperature for the set flow temperature.
6. Pressing F4 will raise the outdoor temperature for the set flow temperature.

< Explanation of compensation curve >

During late spring and summer usually the demand for space heating is reduced. To prevent the heat pump from producing excessive flow temperatures for the primary circuit the compensation curve mode can be used to maximise efficiency and reduce running costs.

The compensation curve is used to restrict the flow temperature of the primary space heating circuit dependent on the outdoor temperature. The FTC3 uses information from both an outdoor temperature sensor and a temperature sensor on the primary circuit supply to ensure the heat pump is not producing excessive flow temperatures if the weather conditions do not require it.

<Holiday mode>

Holiday mode can be activated in 2 ways. Both methods will result in the holiday mode activation screen being shown.

Option 1.

From the main menu screen button E should be pressed. Be careful not to hold down button E for too long as this will turn off the controller and system.

Option 2.

From the main menu screen press button F4. The current settings screen will be displayed. Press button F4 again to access the holiday mode activation screen.

Once the holiday mode activation screen is displayed you can activate/deactivate and select the duration that you would like holiday mode to run for.

- Press button F1 to activate or deactivate holiday mode.
- Use buttons F2, F3 and F4 to input the date which you would like holiday mode to activate or deactivate for space heating.

<Editing holiday mode>

To change the holiday mode settings e.g. the flow temp, you must access the holiday mode menu from the main settings menu.

1. From main menu screen press button B.
2. Use buttons F2 and F3 to scroll through menu until Holiday Mode is highlighted.
3. Press CONFIRM button.
4. The holiday mode status screen is displayed.
5. To change the flow temperature or room temperatures on heating mode press button F3.
6. A list of variables will be displayed. Choose the one you wish to modify using buttons F1/F2 then press CONFIRM.
7. Adjust the temperature using buttons F3 and F2 and press CONFIRM button to save changes.

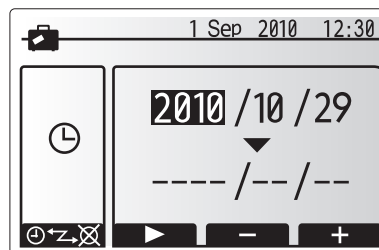
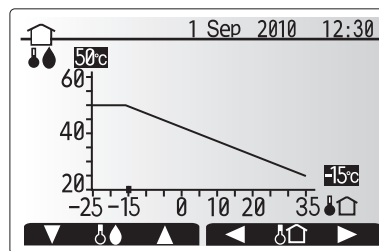
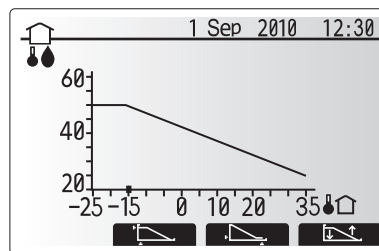

Holiday mode activation screen

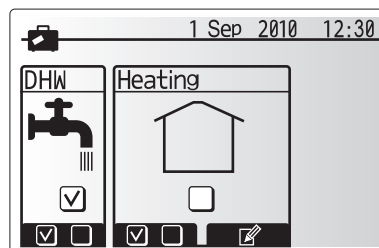

Holiday mode status screen

5 System Set Up

Mode 3 - Schedule timer

The schedule timer mode allows daily and weekly space heating and DHW patterns to be entered.

1. From the main settings menu use F2 and F3 to highlight the schedule timer icon then press CONFIRM.
2. The schedule timer sub menu will be displayed. The icons show the following modes;
 - Heating
 - DHW
3. Use F2 and F3 buttons to move between mode icons press CONFIRM to be shown the PREVIEW screen for each mode.

The PREVIEW screen allows you to view the current settings. Days of the week are displayed across the top of the screen. Where day appears underlined the settings are the same for all those days underlined.

Hours of the day and night are represented as a bar across the main part of the screen. Where the bar is solid black, space heating/DHW (whichever is selected) is allowed.

<Setting the schedule timer>

1. In the PREVIEW menu screen press F4 button.
2. First select the days of the week you wish to schedule.
3. Press F2/F3 buttons to move between days and F1 to check or uncheck the box.
4. When you have selected the days press CONFIRM.
5. The time bar edit screen will be displayed.
6. Use buttons F2/F3 to move to the point at which you do not want the selected mode to be active press CONFIRM to start.
7. Use F3 button to set the required time of inactivity then press CONFIRM.
8. You can add up to 4 periods of inactivity within a 24 hour interval.
9. Press F4 to save settings.

When scheduling heating, button F1 changes the scheduled variable between time and temperature. This enables a lower temperature to be set for a number of hours e.g. a lower temperature may be required at night when the occupants are sleeping.

Notes:

- The schedule timer for space heating and DHW are set in the same way. However for DHW only time can be used as scheduling variable.
- A small rubbish bin character is also displayed choosing this icon will delete the last unsaved action.
- It is necessary to use the SAVE function F4 button to save settings CONFIRM does NOT act as SAVE for this menu.

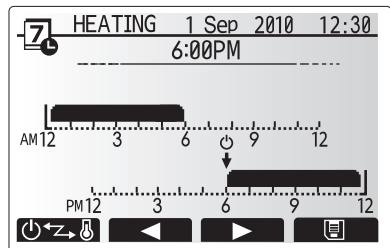
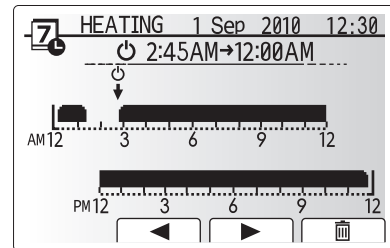
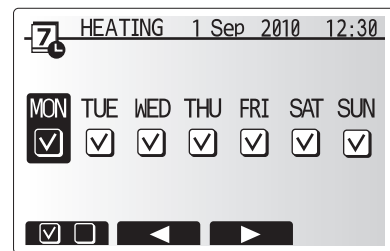
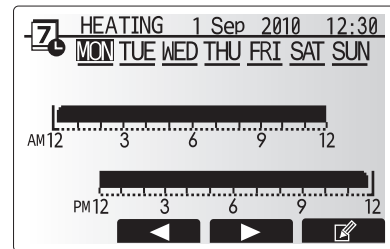
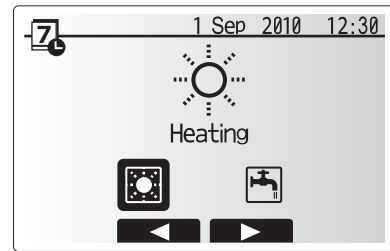

5 System Set Up

■ Service Menu

The service menu provides functions for use by installer or service engineer. It is NOT intended the home owner alters settings within this menu. It is for this reason password protection is required to prevent unauthorised access to the service settings.

1. From the main setting menu use F2 and F3 to highlight the service icon then press CONFIRM.
2. You will be prompted to enter a password. **THE FACTORY DEFAULT PASSWORD IS "0000"**.
3. Press CONFIRM.
(It takes approx. 30 secs to load the service menu.)

The service menu is navigated using the F1 and F2 buttons to scroll through the functions. The menu is split across two screens and is comprised of the following functions;

1. Manual operation
2. Function setting
3. Thermistor adjustment
4. Auxiliary setting
5. Heat source setting
6. Operation setting
7. Running information
8. Thermistor reading
9. Summary of setting
10. Error history
11. Password protection
12. Manual reset

In this Installation Manual, instructions will be given only for the following functions;

1. Auxiliary setting
2. Manual operation
3. Heat source setting
4. Password protection
5. Manual reset

Information on the other functions can be found by consulting the technical or service manuals.

<General operation>

Many functions can not be set whilst the indoor unit is running. The installer should turn **OFF** the unit before trying to set these functions. If the installer attempts to change the settings whilst the unit is running the main controller will display a reminder message prompting the installer to stop operation before continuing. By selecting **Yes**, the unit will cease operation and changes can be made to the service settings.

If text is displayed in white on a black background, CONFIRM button must be pressed to save this choice.

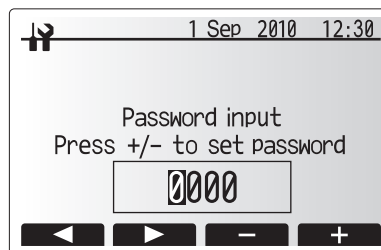

Screen 1 of service menu

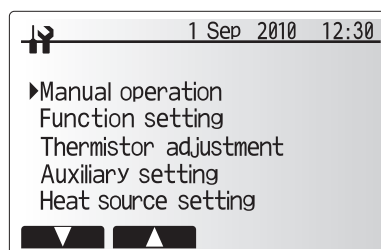

Screen 2 of service menu

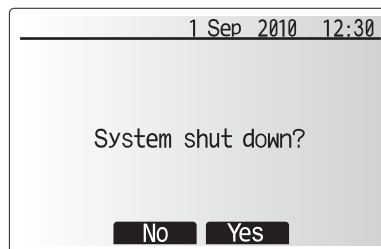

System off prompt screen



5 System Set Up

Auxiliary Setting

This function is used to set the parameters for any auxiliary parts used in the system.

From the service menu use F1 and F2 buttons to highlight Auxiliary setting then press CONFIRM.

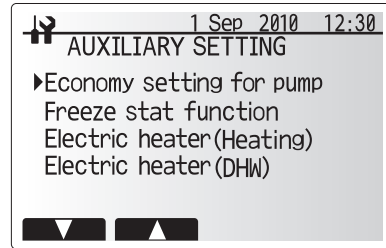

Auxiliary setting menu screen

<Economy settings for pump>

1. From the Auxiliary setting menu highlight Economy Settings for pump.
2. Press CONFIRM.
3. The economy settings for pump screen will be displayed.
4. Use button F1 to switch the pump ON/OFF.
5. Use buttons F3 and F4 to adjust the time the pump will run. (3 - 60 mins)

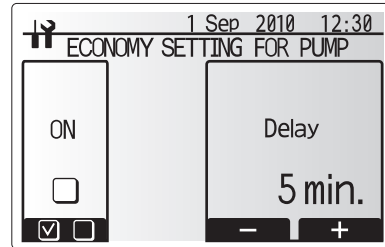

Economy settings for pump screen

<Frost prevention>

1. From the Auxiliary setting menu highlight Freeze Stat Function.
2. Press CONFIRM.
3. The freeze stat function screen will be displayed.
4. Use buttons F3 and F4 to adjust the minimum outdoor temperature which freeze stat function will begin to operate, (3 - 20 °C) or choose *.
If asterisk (*) is chosen freeze stat function is deactivated/disabled (i.e. freeze risk).

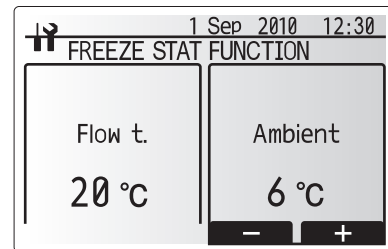

Freeze stat function screen

<Electric heater (Space heating)>

1. From the Auxiliary Setting menu highlight Electric heater (Space heating).
2. Press CONFIRM.
3. The Electric heater (Space heating) screen is displayed.
4. Press F1 button to switch the function ON/OFF.
5. Use F3 and F4 buttons to adjust the time period of heat pump-only operation before the booster heater will assist in space heating. (5 -180mins)

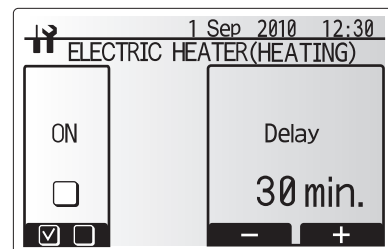

Electric heater (Heating) screen

<Electric heater (DHW)>

1. From the Auxiliary Setting menu highlight Electric heater (DHW).
2. Press CONFIRM.
3. The Electric heater (DHW) screen is displayed.
4. Press F1 button to switch the function ON/OFF.
5. Use F3 and F4 buttons to adjust the time period of heat pump-only operation before the booster heater and the immersion heater (if present) will assist in DHW heating. (15 -30mins)

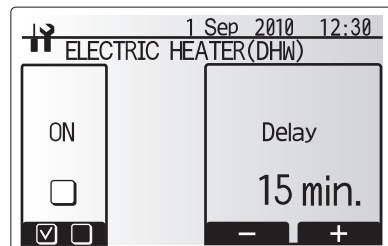

Electric heater (DHW) screen

5 System Set Up

<Manual operation>

During the filling of the system the pump and 3-way valve can be manually overridden using manual operation mode.

When manual operation is selected a small timer icon appears in the screen. The function selected will only remain in manual operation for a maximum of 2 hours. This is to prevent accidental permanent override of the FTC3.

1. From the service menu use F1 and F2 buttons to scroll through list until Manual Operation is highlighted.
2. Press CONFIRM.
3. Manual operation menu screen is displayed.
4. To activate manual operation press the function button under the desired part.
5. To return to service menu press MENU or BACK button.

► Example

Pressing F3 button will switch manual operation mode ON for the main 3-way valve. When filling of the tank is complete the installer should access this menu again and press F3 to deactivate manual operation of the part. Alternatively after 2 hours manual operation mode will no longer be active and FTC3 will resume control of the part.

NOTE:

Manual operation and heat source setting can not be selected if the system is running. A screen will be displayed asking the installer to stop the system before these modes can be activated.

The system automatically stops 2 hours after last operation.

The OUT13 output of the 2-way valve 2 constitutes an inversion of the OUT4 output of the 2-way valve 1.

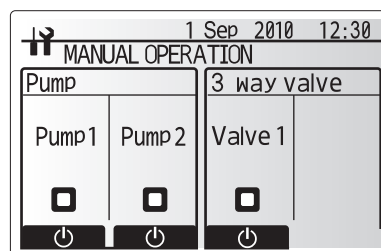

Manual operation menu screen

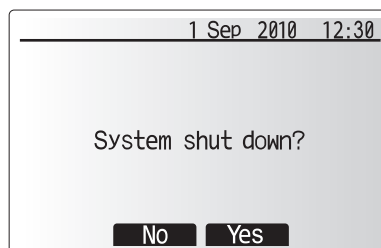

System off prompt screen

<Heat source setting>

The default heat source setting is heat pump and all electric heaters present in the system to be operational. This is referred to as Standard operation on the menu.

1. From the service menu use F1 and F2 buttons to scroll through list until Heat Source Setting is highlighted.
2. Press CONFIRM.
3. Heat source setting menu screen is displayed.
4. Press F3 button until preferred heat source is displayed.
5. Press CONFIRM.
6. To return to service menu press MENU or BACK button.
7. If you wish to return to the service menu without saving the setting press return button. You will be asked if you are sure you wish to cancel the changes. Choose Yes or No as appropriate.

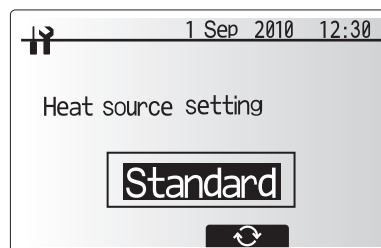

Heat source setting screen

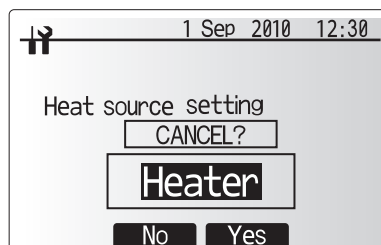

Cancel last action screen

5 System Set Up

Operation Setting Menu

1. To access the Operation setting menu use F1 and F2 buttons to scroll through the service menu until Operation setting is highlighted.
2. Press CONFIRM.
3. Operation setting menu is displayed.

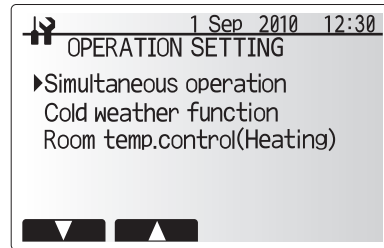

Operation setting menu screen

<Simultaneous Operation>

For periods of very low outside temperature this mode can be used. Simultaneous operation allows both DHW and space heating to be provided simultaneously by using the heat pump to provide space heating whilst the immersion heater (if fitted) provides heating for DHW. This operation is only available if BOTH a DHW tank AND immersion heater are present on the system.

1. From the Operation setting menu use F1 and F2 buttons to scroll through the list until Simultaneous operation is highlighted.
2. Press CONFIRM.
3. Simultaneous operation screen is displayed.
4. To switch simultaneous operation ON/OFF press F1.
5. To alter the temperature at which simultaneous operation starts use F3 and F4.
Note: Range of ambient (outdoor) temperature is -15°C to 10°C (default -15°C).
6. To return to Operation setting menu press BACK.

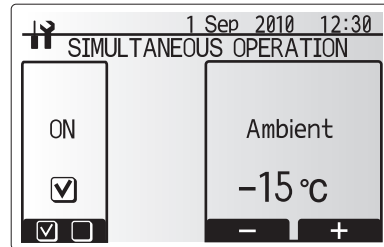

Simultaneous operation screen

<Cold weather function>

For extremely low outdoor temperature conditions when the heat pump's capacity is severely restricted the heating or DHW is provided by only the electric booster heater (and immersion if present). This function is intended for use during extreme cold periods only. Extensive use of direct electrical heaters ONLY will result in higher electric usage and may reduce working life of heaters and related parts.

1. From the Operation setting menu use F1 and F2 buttons to scroll through the list until Cold weather function is highlighted.
2. Press CONFIRM.
3. Cold weather function screen is displayed.
4. To switch Cold weather function ON/OFF press F1.
5. To alter the temperature at which heater switching function starts use F3 and F4.
Note: Range of ambient (outdoor) temperature is -15°C to -10°C (default -15°C)
6. To return to Operation setting menu press BACK.

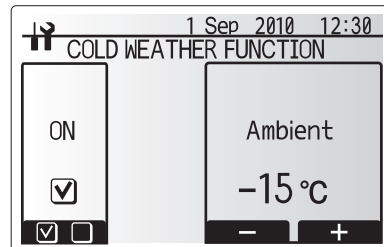

Cold weather function screen

<Room Temp Control (Heating)>

This function allows operational setting of flow temperature range from the Eco-dan and also the time interval at which the FTC3 collects and processes data for the auto adaptation mode.

1. From the Operation setting menu use F1 and F2 buttons to scroll through the list until Room temp. control (HEATING) is highlighted.
2. Press CONFIRM.
3. Room temp. control (HEATING) screen is displayed.
4. To alter the time period at which data will be collected use F1 and F2 buttons to highlight 'Temp. control interval'.
5. Press CONFIRM.
6. Use F3 and F2 buttons to alter the time interval.
Note: Range 10 – 60 minutes at 10 minute intervals (default 10 minutes).
7. To alter the flow temperature limits, use F1 and F2 buttons to highlight 'Flow temperature range'.
8. Press CONFIRM.
Flow temperature range screen is displayed.
9. To alter minimum flow temp. use F1 and F2 buttons.
Note: Range of minimum flow temp. is 25°C to 40°C (default 30°C).
10. To alter maximum flow temp. use F3 and F4 buttons.
Note: Range of maximum flow temp. is 35°C to 60°C (default 50°C)
11. To return to Operation setting menu press BACK twice.

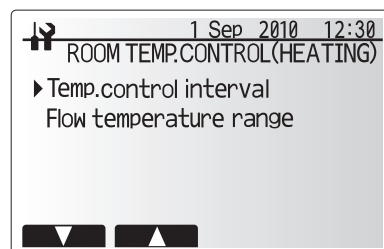

Room temp. control (HEATING) screen

5 System Set Up

<Password protection>

Password protection is available to prevent unauthorised access to the service menu by untrained persons.

1. From the service menu use F1 and F2 buttons to scroll through list until *Password protection* is highlighted.
2. Press CONFIRM.
3. When password input screen is displayed use buttons F1 and F2 to move left and right between the four digits, F3 to lower the selected digit by 1, and F4 to increase the selected digit by 1.
4. When you have input your password press CONFIRM.
5. The password verify screen is displayed.
6. To verify your new password press button F3.
7. Your password is now set and the completion screen is displayed.
8. To return to service menu press MENU or BACK button.



Password input screen

<Resetting the password>

If you forget the password you entered, or have to service a unit somebody else installed, you can reset the password to the factory default of **0000**.

1. From the main settings menu scroll down the functions until Service Menu is highlighted.
2. Press CONFIRM.
3. You will be prompted to enter a password.
4. Hold down buttons F3 and F4 together for 3 secs
5. You will be asked if you wish to continue and reset the password to default setting.
6. To reset press button F3.
7. The password is now reset to **0000**.



Password verify screen

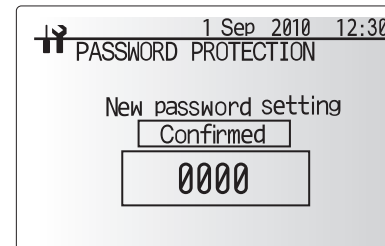

Completion screen

<Manual reset>

Should you wish to restore the factory settings at any time you should use the manual reset function. Please note this will reset ALL functions to the factory default settings.

1. From the service menu use F1 and F2 buttons to scroll through list until Manual Reset is highlighted.
2. Press CONFIRM.
3. The manual reset screen is displayed.
4. Choose either Manual Reset for FTC3 or Main Controller.
5. Press F3 button to confirm manual reset of chosen device.

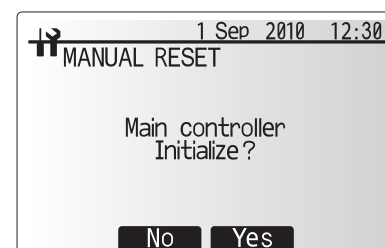
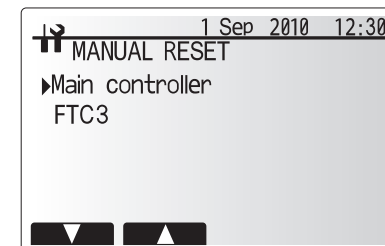

6 Commissioning

■ Pre-commissioning Checklist

Before commissioning the hydrobox system complete the following table to ensure the necessary checks are carried out.

No	System commissioning checklist				Notes
1	Installation location	Air flow around the unit	Outdoor unit	Good/Poor	
2		Maintenance access	Hydrobox	Good/Poor	
			Outdoor unit	Good/Poor	
3	Pipe work	Total pipe length	Outdoor to indoor	m	
4		Height difference	Outdoor to indoor	m	
5		System chemically cleansed and flushed		Yes/No	
6		Insulation type and thickness			
7	Electrical wiring	Correct cables used			
8		Electrical maintenance access		Good/Poor	
9		Connection of mains power source	Outdoor unit electric cable	Type	
				Size	
			Indoor unit electric cable	Type	
				Size	
10		Connection of control cable			
11	Anti-freeze	Refer to product guidelines.		%	
12	Check pre-charge in the expansion vessel(s)			Yes/No	
13	Pressurise circuit to 1 bar			Yes/No	
14	Release air from system			Yes/No	

Outdoor unit operation checklist						
15	Outdoor unit details		Model No.		Serial No.	
16	Power source (V)	1ø	L - N			
		3ø	L1 - L2	L2 - L3	L3 - L1	
17	Excessive vibration/noise		Compressor	Yes/No		
			Fan	Yes/No		
18	Unit mounted on anti-vibration pads (Tico Pads)				Yes/No	
19	Provision made for condensate removal				Yes/No	

For system installations which include DHW cylinders, for known hard water areas, see advice in section 4.2 General.

Notes/Comments:

7 Service and Maintenance

The indoor hydrobox must be serviced **once a year** by a qualified individual. Servicing and maintenance of the outdoor unit should only be done by a Mitsubishi Electric trained technician with relevant qualifications and experience. Any electrical work should be done by a tradesperson with the appropriate electrical

qualifications. Any maintenance or 'DIY' fixes done by a non-accredited person could invalidate the Warranty and/or result in damage to the hydrobox and injury to the person.

Basic Troubleshooting for Hydrobox

Fault symptom	Possible cause	Solution
Water discharges from pressure relief valve	If continual – pressure relief valve seat may be damaged.	Remove cartridge – check seat and renew if necessary.
	If intermittent – expansion vessel charge may have reduced/bladder perished.	Check pressure in expansion vessel. Recharge to 1 bar if necessary. If bladder perished replace vessel.
	System was excessively pressurised at fill stage.	Ensure the fill connection has been physically DISCONNECTED from the mains water supply. With hydrobox cold check pressure in hydrobox. If necessary, discharge/re-fill system to the recommended cold-fill pressure of 1 bar.
	Unit has overheated – thermal controls have failed.	Switch off power to the heat pump. Leave water supply on. Wait until discharge stops. Isolate water supply and replace if faulty.
Noisy pump	Air in pump	Use manual and automatic air vents to release excess air from system. Top up water if necessary to achieve 1bar on primary circuit.
Pump runs for a short time for no reason.	Pump jam prevention mechanism to inhibit the build up of scale.	Normal operation no action necessary.
Heating system does not get up to set temperature.	Prohibit, schedule timer or holiday mode selected.	Check settings and change as appropriate.
	Incorrectly sized radiators	Contact installer
	The room in which the temperature sensor is located is at a different temperature to the rest of the house.	Reposition the temperature sensor to a more suitable room.
	Battery problem *wireless control only	Check the battery power and replace if flat.
Mechanical noise heard coming from the hydrobox.	Heaters switching on/off	Normal operation no action required.
Heating mode has been on standby for a long time (does not start operation smoothly.)	Duration is set to excessively short time at "Economy setting for pump". (Go to "Service menu" → "Auxiliary setting" → "Economy setting for pump").	Set "Economy setting for pump" longer.

Annual Maintenance

It is essential that the hydrobox is serviced at least once a year by a qualified individual any spare parts required **MUST** be purchased from Mitsubishi Electric (safety matter). **NEVER** bypass safety devices or operate the unit without them being fully operational.

<Draining the hydrobox>

WARNING: DRAINED WATER MAY BE VERY HOT

1. Before attempting to drain the hydrobox isolate from the electrical supply to prevent booster heater burning out.
2. Isolate hydrobox from primary water circuit and drain water from hydrobox. Use a suitable heat resistant hose to assist in these operations.
3. Drain any remaining water from booster heater using fitted drain cock and hose to safely drain the unit.
4. After the hydrobox is drained, water remains in the following component parts. Drain water completely by checking the inside of the parts.
 - Strainer (Remove the strainer cover.)
 - Pressure relief valve (Operate the valve.)

<Annual maintenance points>

Use the Annual Maintenance Log Book as a guide to carrying out the necessary checks on the hydrobox and outdoor unit.

Error Codes

Code	Error	Action
L1	Booster heater overheat detection	Flow rate may be reduced check for; <ul style="list-style-type: none"> • Water leakage • Strainer blockage • Pump function (Error code may display during filling of primary circuit, complete filling and reset error code.)
L2	Booster heater thermistor (THW3) failure	Check the resistance of the thermistor.
L3	Circulation water temperature overheat protection	See Action for L1.
L4	Tank water temperature overheat protection	Check the DHW tank temperature.
L5	Indoor unit temperature thermistor (TH1, TH2, THW1, THW2, THW5B) failure	Check the resistance of the thermistor.
L6	Circulation water freeze protection	See Action for L1.
L7	3-way valve (2-way valve) defective	Check the motion of the 3-way valve (2-way valve).
L8	Heating operation error	Re-attach any thermistors that have become dislodged.
L9	Low primary circuit flow rate detected by flow switch	See Action for L1. If the flow switch itself does not work, replace it. The pump valves may be hot, please take care.
J0	Communication failure between FTC3 and wireless receiver	Check connection cable for damage or loose connections.
J1 - J8	Communication failure between wireless receiver and wireless remote controller	Check wireless remote controller's battery is not flat. Check the pairing between wireless receiver to wireless remote controller. Test the wireless communication. (See the manual of wireless system)
E0 - E5	Communication failure between main controller and FTC3	Check connection cable for damage or loose connections.
E6 - EF	Communication failure between FTC3 and outdoor unit	Check that the outdoor unit has not been turned off. Check connection cable for damage or loose connections. Refer to outdoor unit service manual.
E9	Outdoor unit receives no signal from indoor unit.	Check both units are switched on. Check connection cable for damage or loose connections. Refer to outdoor unit service manual.
U*, F*	Outdoor unit failure	Refer to outdoor unit service manual.

Note: To cancel error codes please switch system off (Press button E, on Main Controller, for 3 secs).

7 Service and Maintenance

■ Engineers Forms

Should settings be changed from default, please enter new setting in 'Field Setting' column. This will ease resetting in the future should the system use change or the circuit board need to be replaced.

Commissioning/Field settings record sheet

			Parameters	Default setting	Field setting	Notes	
Main	Option	Forced DHW operation *2	On/Off	Off			
		DHW *2	On/Off/Timer	Off			
		Heating	On/Off/Timer	On			
		Holiday mode	Active/Non active/Set time	Non active			
Setting	DHW *2	Operation mode	Normal/Eco	Normal			
		DHW max. temp	40°C – 60°C	50°C			
		DHW temperature drop	5°C – 30°C	10°C			
		DHW max. operation time	30 – 120 mins	60 mins			
		DHW mode restriction	30 – 120 mins	30 mins			
		Legionella prevention *2	Active	Yes/No	Yes		
			Hot water temp	60°C – 70°C	65°C		
	Frequency		1 – 30 days	15 days			
	Start time		00.00 – 23.00	03.00			
	Max. operation time		1 – 5 hours	3 hours			
	Duration of maximum temperature		1 – 120 mins	30 min			
	Heating		Operation mode	Heating	Flow temp/Compensation curve/Room temp	Room temp	
		Heating room temp		10°C – 30°C	20°C		
		Heating flow temp		25°C – 60°C	45°C		
	Compensation curve	Lo set point	Outdoor ambient temp	-15°C – 35°C	35°C		
			Flow temp	25°C – 60°C	25°C		
		Hi set point	Outdoor ambient temp	-15°C – 35°C	-15°C		
			Flow Temp	25°C – 60°C	50°C		
		Adjust	Outdoor Ambient Temp	-14°C – 34°C	—		
			Flow temp	25°C – 60°C	—		
	Schedule timer	Active	Yes/No	No			
	Holiday	DHW *2	Active/Non active	Non active			
		Heating	Active/Non active	Active			
		Heating room temp	10°C – 30°C	15°C			
		Heating flow temp	25°C – 60°C	35°C			
	Initial settings	Language	ENG/PT/NOR/FIN/NL/DA/IT/SP/SW/GER/FR	ENG			
		°C/°F	°C/°F	°C			
		Temp display	On/Off	Off			
		Time display	hh:mm/hh:mm AM/AM hh:mm	—			
		Room sensor setting	TH1/Main RC/Room RC1-8/(Time/Zone)	TH1			
	Service menu	Manual operation	Supplementary pump or 3 way valve On/Off	Off			
		Thermistor adjustment	-10°C — +10°C	0°C			
Auxiliary setting		Economy setting for pump	Active/Not active	Active			
			Time before pump switched off (3 – 60 mins)*1	10 mins			
		Freeze stat function	Outdoor ambient temperature (3 – 20°C)	5°C			
		Electric heater (Heating)	Space heating: Used/Not Used	Used			
			Electric heater delay timer (5 – 180 mins)	30 mins			
Electric heater (DHW) *2		DHW: Used/Not Used	Used				
		Electric heater delay timer (15 – 30 mins)	15 mins				
Heat source setting		Standard/Heater	Standard				
Operation setting		Simultaneous operation	Active/Inactive	Inactive			
			Outdoor ambient temperature (-15 – 10°C)	-15°C			
		Cold weather function	Active/Inactive	Inactive			
			Outdoor ambient temperature (-15 – -10°C)	-15°C			
		Room temp control (Heating)	Temperature control interval (10 – 60 mins)	10 mins			
Flow temperature range (Maximum temp.) (35 – 60°C)	50°C						
Flow temperature range (Minimum temp.) (25 – 40°C)	30°C						

*1 Decreasing "time before pump switched off" may increase the duration of stand-by in Heating mode.

*2 Only available if DHW tank presents in system.

7 Service and Maintenance

■ Annual Maintenance Log Book

Contractor name		Engineer name	
Site name		Site number	

Hydrobox maintenance record sheet

Warranty number		Model number	
		Serial number	

No.	Mechanical	Frequency	Notes
1	Isolate and drain hydrobox, remove mesh from internal strainer clean and replace.		
2	Open the pressure relief valve, check for unrestricted discharge to the tundish and that the valve reseats correctly. Check there are no blockages in the tundish and associated pipe work.		
3	Drop the primary/heating system pressure to zero check and if necessary top up the expansion vessel (1 bar). Air valve of expansion vessel is TR-412.		
4	Check and if necessary top up the concentration of anti-freeze/inhibitor (if used in the system).		
5	Top up the primary/heating system using an appropriate filling loop and re-pressurise to 1 bar.		
6	Heat system and check pressure does not rise above 3 bar and no water is released from the safety valves.		
7	Release any air from the system.		

Refrigerant models only [EXCEPT EHPX]

1	Refer to outdoor unit manual.	Frequency	Notes
---	-------------------------------	-----------	-------

Electrical

1	Check condition of cables.	Frequency	Notes
---	----------------------------	-----------	-------

2	Check rating and fuse fitted on the electricity supply.		
---	---	--	--

Controller

1	Check field settings against factory recommendations.	Frequency	Notes
---	---	-----------	-------

2	Check battery power of wireless thermostat and replace if necessary.		
---	--	--	--

Outdoor heat pump unit maintenance record sheet

Model number		Serial number	
--------------	--	---------------	--

	Mechanical	Frequency	Notes
1	Inspect grill, heat exchanger fins and air inlet for trapped debris/damage.		
2	Check condensate drain provision.		
3	Check integrity of water pipe work and insulation.		
4	Check all electrical connections.		
5	Check and record the operation voltage.		

* All the above checks should be carried out once a year.

Note:

Within the first couple of months of installation, remove and clean the strainer. This is especially important when installing on an existing system.

In addition to annual servicing it is necessary to replace or inspect some parts after a certain period of system operation. Please see tables below for detailed instructions. Replacement and inspection of parts should always be done by a competent person with relevant training and qualifications.

Parts which require regular replacement

Parts	Replace every	Possible failures
Pressure relief valve (PRV) Air vent (Auto/Manual) Drain cock (Primary circuit) Flexible hose Manometer	6 years	Water leakage due to brass/copper corrosion (Dezincification)

Parts which require regular inspection

Parts	Check every	Possible failures
Immersion heater	2 years	Earth leakage causing circuit breaker to activate (Heater is always OFF)
Pump	20,000 hrs (3 years)	Pump failure

Parts which must NOT be reused when servicing

- * O-ring
- * Gasket

Note:
Always replace the gasket for pump with a new one at each regular maintenance (every 20,000 hours of use or every 3 years).

8 Supplementary information

Refrigerant recovery (pump down) for split systems only

For split system the following procedures should be followed to recover system refrigerant:

Note) Pump down operation can not be activated by switching the pump down switch (SWP) or test run switch on the outdoor unit PCB.

Ensure both the outdoor unit and the indoor unit are in emergency mode before carrying out the following.

For pump down operation in split systems both the indoor and the outdoor unit must be in emergency mode.

Please see the following instructions on how to activate emergency mode.

Before carrying out the pump down, ensure the water pump is functioning correctly and L9 error code is not displayed on the main controller.

If there is insufficient water circulation, the circuit may freeze causing damage to the plate HEX.

If there is a fault with the pump or L9 error code is displayed on the main controller, do not attempt pump down operation.

In this case a refrigerant recovery machine must be used.

1. Isolate outdoor unit from power supply by switching OFF relevant circuit breaker.
If the indoor unit is powered independently to the outdoor unit, ensure that BOTH units are isolated from the power supply.
2. Fully close the stop valve on the refrigerant (liquid) pipe and attach the pressure gauge to the port on the low pressure side of the compressor refrigerant pipe work.
Change the position of the connector CN31 to ON and change DipSW4-2 to OFF on the outdoor unit PCB.
Change the DipSW4-5 on the indoor unit to ON.
3. Switch ON power to the outdoor unit.
If the indoor unit is powered independently, switch on power to the indoor unit FIRST, then switch on power to the outdoor unit.
Outdoor and indoor unit will start operating in emergency mode.
Note) If the outdoor unit is operated whilst the indoor unit is switched off, this could cause SERIOUS DAMAGE to the plate HEX.
Always ensure the indoor unit power supply is ON and water pump is operating before switching ON power to the outdoor unit.
After reconnecting power supply, ensure the water pump is operating correctly.
If the water pump is not operating normally, then this could cause the water circuit to freeze and DAMAGE the plate HEX.
4. When the pressure gauge reads close to 0MPa (G), close the valve on the refrigerant (gas) pipe and then switch power to outdoor unit OFF.
If the indoor unit is powered independently ensure power supply for unit is OFF.
Note) It is important that after closing the valve on the refrigerant (gas) pipe the power supply is QUICKLY switched OFF.
If the system is running at a pressure of 0MPa (G) or lower, it may cause DAMAGE to the compressor.
5. After completing the pump down operation, return the position of the connector CN31 on the outdoor unit PCB to OFF.
Change the Dip SW4-5 on the indoor unit to OFF.

EC DECLARATION OF CONFORMITY
EG-KONFORMITÄTSERKLÄRUNG
DECLARATION DE CONFORMITÉ CE

EG-CONFORMITEITSVERKLARING
DECLARACIÓN DE CONFORMIDAD CE
DICHIARAZIONE DI CONFORMITÀ CE

DECLARAÇÃO DE CONFORMIDADE CE
EU-OVERENSTEMMELSESERKLÆRING
EG-DEKLARATION OM ÖVERENSTÄMMELSE

CE-ERKLÆRING OM SAMSVAR
CE-VAAITUMUSTENMUKAISUUSVAKUUTUS

mitsubishi electric air conditioning systems europe ltd.
NETTLEHILL ROAD, HOUSTOUN INDUSTRIAL ESTATE, LIVINGSTON, EH54 5EQ, SCOTLAND, UNITED KINGDOM

hereby declares under its sole responsibility that the heating system components described below for use in residential, commercial and light-industrial environments:
erklärt hiermit auf seine alleinige Verantwortung, dass die unten beschriebenen Zubehörteile für das Heizungs-System zur Benutzung im häuslichen, kommerziellen und leicht-industriellen Umfeld:
déclare par la présente et sous son entière responsabilité que les composants du système de chauffage décrits ci-dessous pour l'utilisation dans des environnements résidentiels, commerciaux et d'industrie légère :
verklaart hierbij als enige verantwoordelijke dat de componenten van het verwarmingsstroom die hieronder worden beschreven, bedoeld zijn voor gebruik in woonomgevingen en in commerciële en licht industriële omgevingen:
declara por la presente bajo su responsabilidad exclusiva que los componentes del sistema de calefacción descritos a continuación para su uso en zonas residenciales, comerciales y para la industria ligera:
con la presente dichiara, sotto la sua esclusiva responsabilità, che i componenti dell'impianto di riscaldamento descritto di seguito, destinato all'uso in ambienti residenziali, commerciali e industriali:
através da presente declara sob sua única responsabilidade que os componentes do sistema de aquecimento abaixo descritos para uso residencial, comercial e de indústria ligeira:
erklærer hermed under eneansvar, at de herunder beskrevne komponenter til opvarmning til brug i privat boligbyggen, erhvervsområder og inden for let industri:
intygat härmed att uppvärmningssystemkomponenterna som beskrivs nedan är för användning i bostäder, kommersiella miljöer och lätt industri:
erklærer hermed som sitt ansvar, ene og alene, at komponentene i varmesystemet som beskrives nedenfor og som er beregnet for bruk i bolig-, forretnings- og lettindustri miljøer:
vakuuttaa täten asiasta yksin vastuussa, että alla kuvattut lämmitysjärjestelmän osat, jotka on tarkoitettu käytettäväksi asuin-, toimisto- ja kevyen teollisuuden ympäristöissä:

MITSUBISHI ELECTRIC, EHSC-VM6A, EHSC-YM9A, EHPX-VM2A

Note: Its serial number is on the nameplate of the product.
Hinweis: Die Seriennummer befindet sich auf dem Kennschild des Produkts.
Remarque : Le numéro de série de l'appareil se trouve sur la plaque du produit.
Opmerking: het serienummer staat op het naamplaatje van het product.
Nota: El número de serie se encuentra en la placa que contiene el nombre del producto.
Nota: il numero di serie si trova sulla targhetta del prodotto.

Nota: o número de série encontra-se na placa que contém o nome do produto.
Bemærk: Serienummeret står på produktets fabrikksskilt.
Obs: Serienumret finns på produktens namnplåt.
Merk: Serienummeret befinner seg på navneplaten til produktet.
Huomautus: Sen sarjanumero on tuotteen nimikilvessä.

Directives
Richtlinien
Directives
Richtlijnen
Directivas
Direttive

Directivas
Direktiver
Direktiv
Direktiver
Direktiivit

2006/95/EC: Low Voltage
2006/42/EC: Machinery
2004/108/EC: Electromagnetic Compatibility

Our authorized representative in EU, who is authorized to compile the technical file, is as follows.
Unser autorisierter Vertreter in der EU, der ermächtigt ist die technischen Daten zu kompilieren, ist wie folgt.
Notre représentant agréé dans L'UE, qui est autorisé à compiler le fichier technique, est le suivant.
Onze geautoriseerde vertegenwoordiger in de EU, die gemachtigd is het technische bestand te compileren, is als volgt.
Nuestro representante autorizado en la UE, que está autorizado para compilar el archivo técnico, es el siguiente.
Il nostro rivenditore autorizzato nell'UE, responsabile della stesura della scheda tecnica, è il seguente.

O nosso representante autorizado na UE, que está autorizado para compilar o ficheiro técnico, é o seguinte:
Vores autoriserede repræsentant i EU, som er autoriseret til udarbejdelse af den tekniske fil, er følgende.
Vår EG-representant som är auktoriserad att sammanställa den tekniska filen är följande.
Vår autoriserte EU-representant, som har autorisasjon til å utarbeide denne tekniske filen, er som følger.
Valtuutettu edustajamme EU:ssa, jolla on lupa laatia tekninen tiedosto, on seuraava.

MITSUBISHI ELECTRIC EUROPE, B.V.
HARMAN HOUSE, 1 GEORGE STREET, UXBRIDGE, MIDDLESEX UB8 1QQ, U.K.
Masami KUSANO
Product Marketing Director

Issued
LIVINGSTON

28 April , 2011

Akio FUKUSHIMA
President

Installers: Please be sure to put your contact address/telephone number on
this manual before handing it to the customer.



HEAD OFFICE: TOKYO BLDG., 2-7-3, MARUNOUCHI, CHIYODA-KU, TOKYO 100-8310, JAPAN
Authorized representative in EU: MITSUBISHI ELECTRIC EUROPE B.V.
HARMAN HOUSE, 1 GEORGE STREET, UXBRIDGE, MIDDLESEX UB8 1QQ, U.K.
This product is made by Mitsubishi Air Conditioning Systems Europe Ltd.: NETTLEHILL Rd, HOUSTOUN IND ESTATE,
LIVINGSTON, EH54 5EQ, UK