

| | | | | | | | | |
|--|--|------|------|------|-------------|------|------|------|
| MODEL | LGH-15RVX-E | | | | SIGN | | | |
| Heat exchange system | Heat recovery ventilating system | | | | | | | |
| Heat exchanger material | Special treated paper plate heat exchanger | | | | | | | |
| Cladding | Galvanized steel sheet | | | | | | | |
| Heat insulation material | Self-extinguishing urethane foam | | | | | | | |
| Motor | DC motor | | | | | | | |
| Blower | 180mm diameter centrifugal fan | | | | | | | |
| Filter | Non-woven fabrics filter (Gravitational method 82% EU-G3) | | | | | | | |
| Surrounding air condition | Shall be between -10°C and 40°C, 80%RH or less | | | | | | | |
| Suction air condition | Shall be lower than 40°C, 80%RH | | | | | | | |
| Supply fan operation under low outdoor temperature | -10°C to -15°C : Intermittent operation 60 min ON, 10 min OFF. -15°C or less : Intermittent operation 55 min OFF, 5 min ON. | | | | | | | |
| Function | Heat recovery ventilation/ Bypass ventilation, Fan speed 1,2,3,4 | | | | | | | |
| Weight | 20kg | | | | | | | |
| Electrical power supply | 220-240V/50Hz, 220V/60Hz | | | | | | | |
| Ventilation mode | Heat recovery mode | | | | Bypass mode | | | |
| Fan speed | SP4 | SP3 | SP2 | SP1 | SP4 | SP3 | SP2 | SP1 |
| Running current [A] | 0.40 | 0.24 | 0.15 | 0.10 | 0.41 | 0.25 | 0.15 | 0.10 |
| Input power [W] | 49 | 28 | 14 | 7 | 52 | 28 | 14 | 8 |
| Air volume [m ³ /h] | 150 | 113 | 75 | 38 | 150 | 113 | 75 | 38 |
| [L/s] | 42 | 31 | 21 | 10 | 42 | 31 | 21 | 10 |
| External static pressure [Pa] | 95 | 54 | 24 | 6 | 95 | 54 | 24 | 6 |
| Exchange efficiency [%] | 80.0 | 81.0 | 83.0 | 84.0 | - | - | - | - |
| Temperature | 80.0 | 81.0 | 83.0 | 84.0 | - | - | - | - |
| Enthalpy Heating | 73.0 | 75.5 | 78.0 | 79.0 | - | - | - | - |
| Enthalpy Cooling | 71.0 | 74.5 | 78.0 | 79.0 | - | - | - | - |
| Noise [dB] | 28.0 | 24.0 | 19.0 | 17.0 | 29.0 | 24.0 | 19.0 | 18.0 |
| Insulation resistance | 10MΩ or more | | | | | | | |
| Direct strength | AC 1500V 1 minute | | | | | | | |

■ Characteristic curve

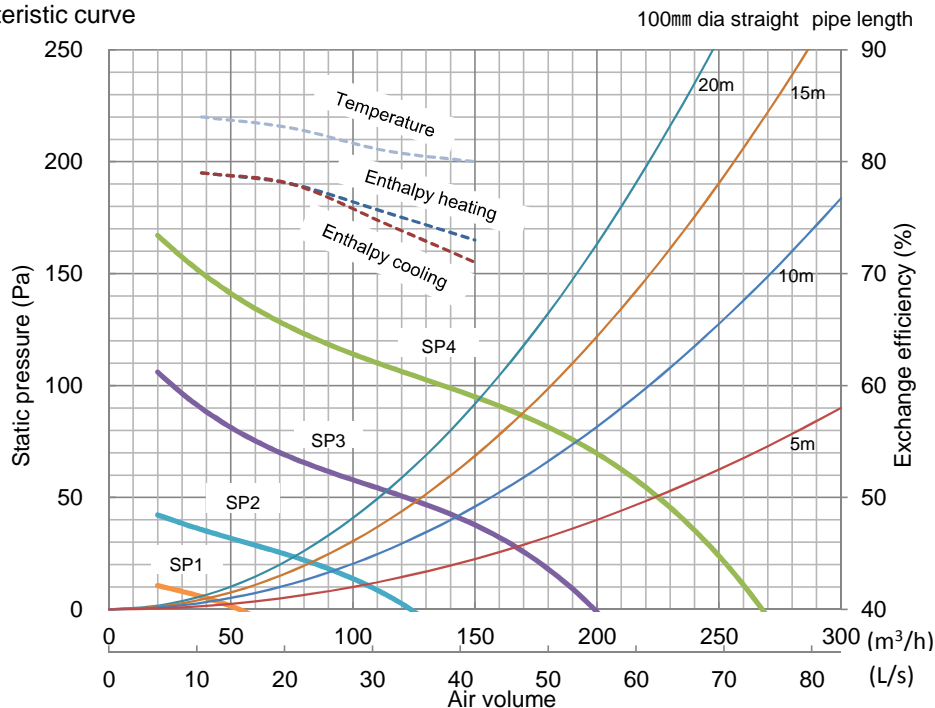

■ Attention

- The running current, the input power, the efficiency and the noise are based on the rating air volume, and 230V/50Hz. The noise is measured at 1.5m under the center of the unit in an anechoic chamber.
- Temperature exchange efficiency (%) is based on winter condition.
- Heat recovery ventilation mode starts automatically while detecting OA temperature lower than 8°C, even Bypass mode is selected. Remote controller continues to display "Bypass ventilation" in this case.
- Mitsubishi Electric measures figures in the chart according to Japan Industrial Standard (JIS B 8628), therefore the characteristic curves are measured by chamber method.
- The noise level at 1.5m away from outlets in the 45° direction is about 13dB greater than the indicated value at fan speed4.
- On-site measurements by pitot tube method could be as much 20% difference from JIS test room conditions. If the measuring point is close to sources of turbulence like bends, contractions and dampers etc., it is difficult to measure air volume correctly. A straight duct length more than 10D (D=duct diameter) from the source of turbulence is recommended for correct measurement. On-site measurement should therefore be measured in accordance with BSRIA guideline (Commissioning Air Systems. Application procedures for buildings AG3/89.3(2001)).
- Following supply fan power up function, 3 level up and 4 level up in fan speed 4, are not available.

※Specification may be subject to change without notice.

| | | | | |
|--|-------------|---------------------|--------------------------|--|
| SPECIFICATIONS | DATE | TYPE | CEILING RECESSED LOSSNAY | |
| | 22-Sep-2014 | MODEL | LGH-15RVX-E | |
| MITSUBISHI ELECTRIC CORPORATION | NUMBER | N14HHGU0027A | 1/5 | |

■ Outline drawings

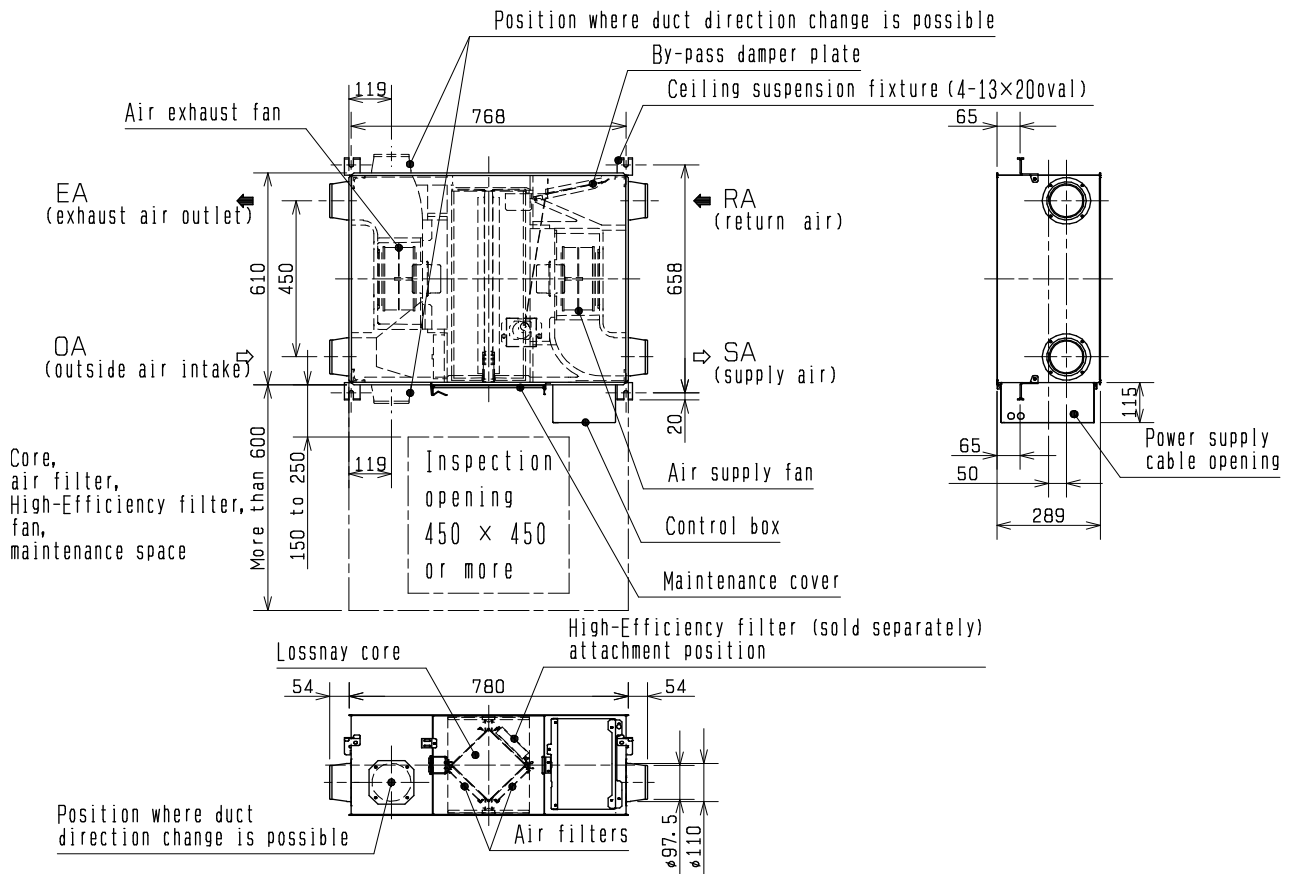

| | | |
|--|------|-------|
| | UNIT | SCALE |
| | mm | N.T.S |

■ Attention

- When using the product where it is exposed to high temperatures and humidity (40°C or more, RH 80% or more), or where fog occurs frequently, moisture is likely to condense in the core, and may result in condensation build up in the unit. The product should not be used under such conditions.
- Outdoor air may enter the Lossnay owing to the pressure difference between indoor and outdoor or external winds even when the product is not operated. It is recommended to install an electrically operated damper to block the outdoor air.
- In a cold weather area, an area with strong external winds or where fog occurs frequently, cold outdoor air, external winds or fog may be introduced into the product when its operation is stopped. It is recommended to install an electrically operated damper.
- In a cold weather area, or others, dewing or freezing could occur on the main unit, where the duct is connected, or other sections, depending on the conditions of outdoor air and indoor temperature and moisture, even if they are within the range of operating conditions. Make sure to check the operating conditions and other precautions, and do not use the product if dewing or freezing is anticipated.
- The outside ducts must be tilted at a gradient (1/30 or more) down toward the outdoor louvers from the Lossnay, and properly insulated. (The entry of rain water may cause power leakage, fire, or damage to household property.)
- The two outdoor ducts must be covered with heat-insulating material in order to prevent condensation from forming. If it is expected that the ambient temperature around the place where the Lossnay unit is installed will be high during the summer air conditioning season, it is recommended that the indoor ductwork should be covered with insulation material.
- Inspection opening (450 × 450mm or more) must be installed on the filter and Lossnay core removal side.
- Before starting installation, be sure to fix ceiling suspension fixture with the attached screws according to the installation manual.

※Specification may be subject to change without notice.

| | | | | |
|---------------------------------|-------------|---------------|--------------------------|-----|
| OUTLINE DRAWINGS | DATE | TYPE MODEL | CEILING RECESSED LOSSNAY | |
| | 22-Sep-2014 | | LGH-15RVX-E | |
| MITSUBISHI ELECTRIC CORPORATION | NUMBER | N14HHGU0027A | | 2/5 |

■ Wiring diagrams

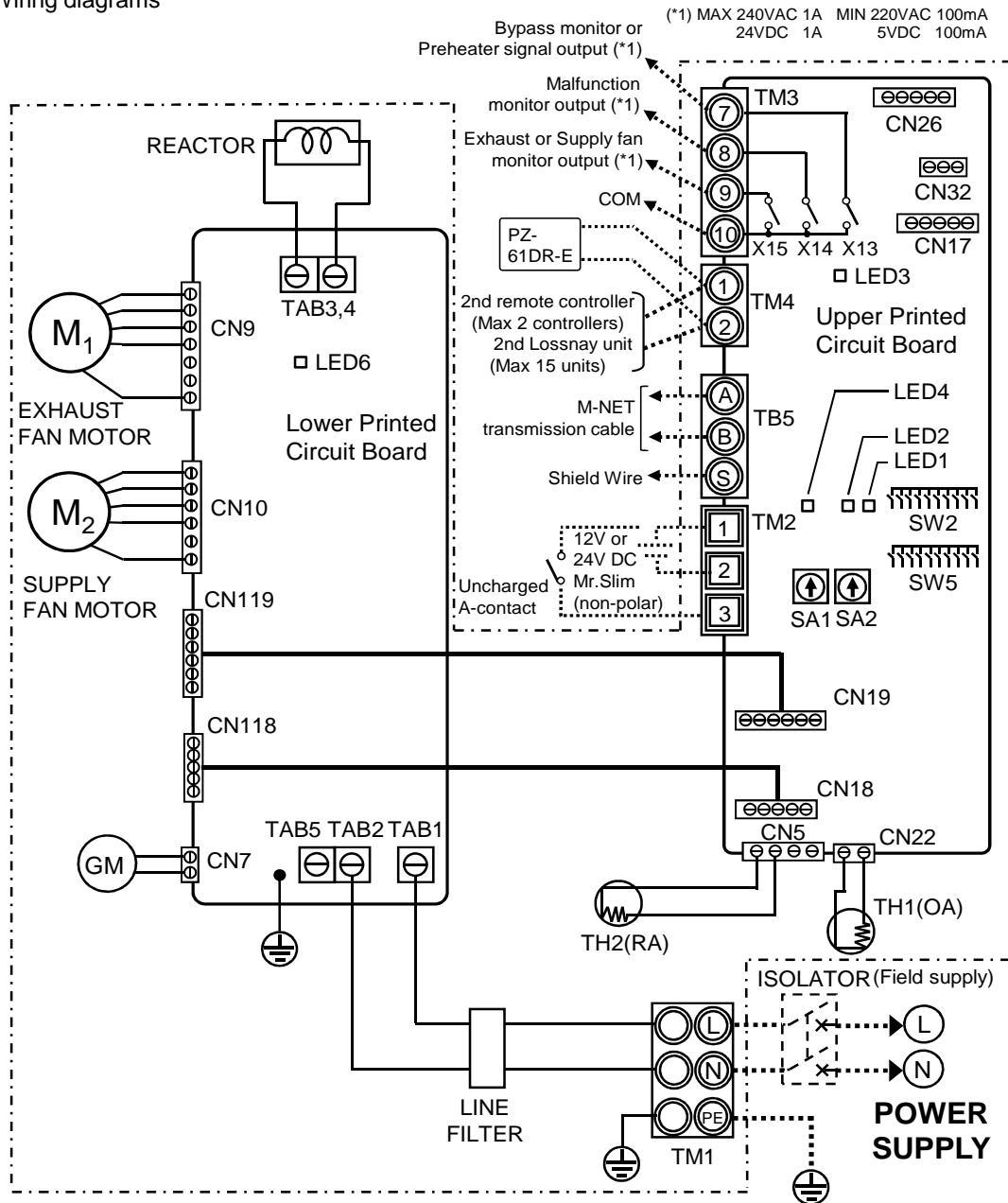

Definition of symbols

| | | |
|---|--|---|
| M1: Motor for exhaust fan M2: Motor for supply fan GM: Motor for By-pass damper TH1: Thermistor for outside air TH2: Thermistor for return air SW2,5: Switch (Function selection) TM1: Terminal block (Power supply) TM2: Terminal block (External control input) TM3: Terminal block (Monitor output) TM4: Terminal block (Transmission cable) TB5: Terminal block (M-NET Transmission cable) TAB1, TAB2: Connector (Power supply) TAB3, TAB4: Connector (Reactor) | X13: Relay contact X14: Relay contact X15: Relay contact CN5: Connector (Thermistor RA) CN7: Connector (Motor for By-pass damper) CN9: Connector (Fan motor) CN10: Connector (Fan motor) CN17: Connector (Fan speed 1/2/3/4) CN18: Connector CN118: Connector CN19: Connector CN119: Connector CN22: Connector (Thermistor OA) | CN26: Connector (By-pass, 0-10 VDC Fans speed control) CN32: Connector (Remote control selection) SA1: Address setting rotary switch (10 digit) SA2: Address setting rotary switch (1 digit) LED1 to LED5: Inspection indicator lamp LED6: Power supply indicator lamp SYMBOL : Terminal block : Connector on PCB |
|---|--|---|

■ Attention

1. With this product, the wiring installation method will vary according to the design of the system.
2. Perform electrical installation to meet local electrical regulations.
3. Always use double insulated PVC cable for the transmission cables.
4. Wiring work must be performed by qualified professionals.
5. All supply circuits must be disconnected before obtaining access to the terminal devices.

※Specification may be subject to change without notice.

| | | | | |
|---------------------------------|-------------|--------------|--------------------------|--|
| WIRING DIAGRAMS | DATE | TYPE | CEILING RECESSED LOSSNAY | |
| | 22-Sep-2014 | MODEL | LGH-15RVX-E | |
| MITSUBISHI ELECTRIC CORPORATION | NUMBER | N14HHGU0027A | 3/5 | |

■ Lossnay model selection advices

1. Operating environment
Install this product in an environment where the temperature ranges from -10°C to +40°C and the relative humidity is less than 80%RH. If condensation is expected to form, the fresh outside air should be treated.
2. Do not use under high temperature and humidity condition
Condensation will occur and water will gather inside the Lossnay cores under high temperature and humidity condition, such as warm swimming pool, bathroom, greenhouse or foggy places.
3. Condition of outdoor, indoor and return air
Avoid using Lossnay under air condition with acid, alkalis, organic solvent, oil mist, paint, or harmful gas as pesticide, corrosive gas, etc.
4. Insulation failure caused by salt or sulphur air and hot spring steam, rust, fire or malfunction may occur.
Installing high quality filters inside outdoor air duct if the Lossnay operates in salt or sulphur air conditions.
5. Intake of mist or outdoor air during off-mode operation
Outdoor air or mist may flow through the duct into your room when Lossnay is in off-mode in windy and foggy areas. To prevent intake of outdoor air or fog, a damper is advised to be installed.
6. Entry of insects
When using the product in an environment where there is a window, or opening near the outdoor hood, so that insects are likely to gather around the interior or exterior light, take note that small insects may intrude into the Lossnay filters.
7. By-pass ventilation
In the case of "By-pass" ventilation, the supply air temperature slightly rises more than the outside air temperature because of the effect around the ducts or the unit motors.
8. Usage of M-NET.
When solely using Lossnay units, power supply unit is required to connect to centralised controller.
Number of power supply units or the transmission boosters should correspond with the connected Lossnay units.

■ Caution for installation

1. Do not modify the unit as it may cause malfunction.
2. Do not install Lossnay unit vertically or on an incline. It may cause malfunction or decrease performance.
3. Leave sufficient space for maintenance purposes.
4. The location of the air inlet
Take care in locating air inlet to prevent intake of dirty air or disgusting smell from exhaust gas of factory, air from rubbish disposal, etc.
5. Take precautions when using the product in a quiet location.
6. Heat insulation foam for duct
Take care as below to prevent duct condensation.
 - ① The two outdoor ducts (OA and EA) must be covered with heat-insulating material in order to prevent condensation.
 - ② If it is expected that the ambient temperature around the place where the Lossnay unit is installed will be high during the summer air conditioning season, it is recommended that the indoor ductwork should be covered with insulation material.
 - ③ Outdoor air may come into the unit when not in operation the pressure difference between indoor and outdoor or the outdoor wind. In this case you should install a damper.
 - ④ It is possible for condensation and freezing to occur in the cold regions inside the unit because of the outdoor air condition or humidity condition above ceiling. Make sure to install supplemental insulation foam.
 - ⑤ In the case that air condition around Lossnay unit is high temperature in summer, it is recommended that there are heat insulation foam on indoor side duct to prevent heat recovery decreasing by warming indoor duct.
In winter, it is possible to cool indoor side duct without heat insulation foam on indoor side duct.
7. Prevent entry of rainwater into Lossnay unit
Install weather louver or "Weather cover" for OA inlet & EA outlet. This is to prevent rainwater entering the Lossnay unit. Ducts to outdoor (OA and EA) should decline by 1/30 or more.
8. Install the anchor bolts to ensure the product's weight or earthquake load. Correctly rated wire/chain may also be used.
9. Do not install this product in a place where it is exposed to ultraviolet light. UV may damage covering insulation.
10. Electrical Work
A single pole isolator must be installed at the origins of mains power supply.
Use single flush box, to support remote controller.
Must connect ground wiring.
When connecting external devices (electrically operated damper, lamp, monitoring unit, etc.) using output signals of the Lossnay unit, make sure to install safety equipment for the external devices.
(It could cause fire, damage, etc. without safety equipment)

※Specification may be subject to change without notice.

| | | | | |
|--|-------------|---------------|--------------------------|-----|
| SAFTY NOTES | DATE | TYPE MODEL | CEILING RECESSED LOSSNAY | |
| | 22-Sep-2014 | | LGH-15RVX-E | |
| MITSUBISHI ELECTRIC CORPORATION | | NUMBER | N14HHGU0027A | 4/5 |

11. Duct heater

In the case of installing a duct heater interlocked with Lossnay, be sure to observe the following:

- ① Select a duct heater in compliance with local and national laws, ordinances, and standards.
Select a duct heater that has obtained the CE mark.
- ② Always select a heater that is equipped with a non-self-resetting safety device.
Do not directly supply power from the Lossnay unit to the duct heater. Doing so could cause fire.
- ③ Install a circuit breaker for the duct heater in compliance with all applicable laws, ordinances, and standards.
- ④ Install the duct heater separated from the product by a distance of 2 m or more.
Failure to do so may result in equipment damage due to the transmission of residual heat from the heater.
- ⑤ When using a heater without a temperature control function, select a heater with a capacity that is matched to the air volume.
- ⑥ Do not use the heater outside the set air volume.
If the heater's capacity is too larger, this may result in the heater frequently turning ON/OFF.
If the heater's capacity is too small, this may result an inability to heat.
- ⑦ Ensure that the duct heater and Lossnay are wired and that the Lossnay function settings have been configured, and then always check operation by trial operation.

■ Maintenance and lifetime

Remove all dust and dirt on air filters and Lossnay cores at regular intervals to prevent a deterioration in the Lossnay function.

Refer to each model's operation instructions for the suggested maintenance period and methods. General indication of lifetime of the main parts is as below. Time below is unrelated to guaranteed period for service. And parts exchange period varies with usage condition.

- Lossnay cores : Around 10 years with maintenance at stated periods.
- Air Filters : Around 5 years with maintenance at stated periods
- High efficiency filters : 3000 hours
- Motor : 30000 hours

※Specification may be subject to change without notice.

| | | | | |
|--|-------------|---------------|--------------------------|-----|
| SAFTY NOTES | DATE | TYPE MODEL | CEILING RECESSED LOSSNAY | |
| | 22-Sep-2014 | | LGH-15RVX-E | |
| MITSUBISHI ELECTRIC CORPORATION | | NUMBER | N14HHGU0027A | 5/5 |