

## B.1 WALL-MOUNTED

<b>B.1.1 SPECIFICATIONS .....</b>	<b>B-2</b>
B.1.1.1 Cool Only .....	B-2
B.1.1.2 Heat Pump .....	B-4
<b>B.1.2 OUTLINES AND DIMENSIONS .....</b>	<b>B-6</b>
B.1.2.1 Cool Only .....	B-6
B.1.2.2 Heat Pump .....	B-9
<b>B.1.3 WIRING DIAGRAM .....</b>	<b>B-12</b>
B.1.3.1 Cool Only .....	B-12
B.1.3.2 Heat Pump .....	B-15
<b>B.1.4 REFRIGERANT SYSTEM DIAGRAM .....</b>	<b>B-18</b>
B.1.4.1 Cool Only .....	B-18
B.1.4.2 Heat Pump .....	B-20
<b>B.1.5 PERFORMANCE CURVES .....</b>	<b>B-22</b>
B.1.5.1 Cool Only/Heat Pump .....	B-23
<b>B.1.6 PERFORMANCE DATA .....</b>	<b>B-26</b>
B.1.6.1 Cool Only .....	B-26
B.1.6.2 Heat Pump .....	B-36
<b>B.1.7 NOISE CRITERIA CURVES .....</b>	<b>B-47</b>
B.1.7.1 Cool Only/Heat Pump .....	B-47
<b>B.1.8 REMOTE CONTROLLER OPERATION .....</b>	<b>B-51</b>
B.1.8.1 MSC Type .....	B-51
B.1.8.2 Cool Only .....	B-52
B.1.8.3 Heat Pump .....	B-53
<b>B.1.9 TROUBLESHOOTING .....</b>	<b>B-54</b>
<b>B.1.10 INSTALLATION PROCEDURE .....</b>	<b>B-57</b>
B.1.10.1 Cool Only/Heat Pump .....	B-57
<b>B.1.11 MICROPROCESSOR CONTROL .....</b>	<b>B-70</b>
B.1.11.1 MSC Series .....	B-70
B.1.11.2 MS Series .....	B-80
B.1.11.3 MSH Series .....	B-87

## B.1.1 SPECIFICATIONS

### B.1.1.1 Cool Only

Indoor model			MSC-C07TV	MSC-C09TV	MSC-C12TV
Function			Cooling		
Indoor unit power supply			Single phase, 230V, 50Hz		
Capacity	Air flow (High)	m <sup>3</sup> /h	474		588
Electrical data	Power outlet	A	10		
	Running current	A	0.17		0.19
	Power input	W	35		40
	Power factor	%	90		92
	Starting current	A	—		
	Fan motor current	A	0.17		0.19
Fan motor	Model		RC4V19-BA		
	Winding resistance (at 20°C)	Ω	WHT-BLK 292 BLK-RED 325		
	Dimensions W×H×D	mm	850×278×191		
	Weight	kg	9		10
	Air direction		5		
Special remarks	Sound level (High)	dB	36		39
	Fan speed (High)	rpm	950		1,020
	Fan speed regulator		3		
	Thermistor RT11 (at 25°C)	kΩ	10		
	Thermistor RT12 (at 25°C)	kΩ	10		
Outdoor model			MU-C07TV	MU-C09TV	MU-C12TV
Outdoor unit power supply			Single phase, 230V, 50Hz		
Capacity	Capacity	kW	2.25	2.5	3.55
	Dehumidification	ℓ/h	0.8	1.0	1.6
	Outdoor air flow	m <sup>3</sup> /h	1,686		1,914
Electrical data	Power outlet	A	10		
	Running current	A	3.03	3.53	6.01
	Power input	W	695	795	1,330
	Auxiliary heater	A (kW)	—		
	Power factor	%	99	98	96
	Starting current	A	18	19	34
	Compressor motor current	A	2.75	3.25	5.64
	Fan motor current	A	0.29		0.37
	Coefficient of performance (C.O.P)		3.08	3.01	2.59
Compressor	Model		RE-130VGSHT	RE-145VGSHT	RE-231VHSHT
	Output	W	650	700	1,100
	Winding resistance (at 20°C)	Ω	C-R 4.18 C-S 5.76	C-R 4.03 C-S 5.71	C-R 2.25 C-S 4.07
Fan motor	Model		RA6V23-EB		RA6V33-CB
	Winding resistance (at 20°C)	Ω	WHT-BLK 258 BLK-RED 385		WHT-BLK 176 BLK-RED 413
	Dimensions W×H×D	mm	780×540×255		
	Weight	kg	32		34
Special remarks	Sound level	dB	45		49
	Fan speed	rpm	645		725
	Fan speed regulator		1		
	Refrigerant filling capacity (R407C)	kg	0.77	0.88	0.90
	Refrigerating oil (Model)	cc	350 (NEO22)		620 (NEO22)

**NOTE:** Test conditions are based on JIS C 9612.

Cooling : Indoor Dry-bulb temperature27°C / Wet-bulb temperature19°C

Outdoor Dry-bulb temperature35°C / Wet-bulb temperature24°C

Indoor model			MS-C18TV	MS-C24TV
Function			Cooling	
Power supply			Single phase, 230V, 50Hz	
Capacity	Capacity	kW	5.1	6.4
	Dehumidification	ℓ/h	2.4	3.1
	Air flow (High)	m <sup>3</sup> /h	756	816
Electrical data	Power outlet	A	15	25
	Running current	A	9.3	12.7
	Power input	W	2,100	2,840
	Auxiliary heater	A (kW)	—	
	Power factor	%	98	97
	Starting current	A	50	84
	Fan motor current	A	0.25	0.29
	Coefficient of performance (C.O.P)			2.43
Fan motor	Model		RA4V27-EF	RA4V27-EE
	Winding resistance (at 20°C)	Ω	WHT-BLK183.8 BLK-RED250.5	
Dimensions W×H×D		mm	1,015×320×190	
Weight		kg	14	
Special remarks	Air direction		5	
	Sound level (High)	dB	42	45
	Fan speed (High)	rpm	1,180	1,260
	Fan speed regulator		3	
	Thermistor RT11 (at 25°C)	kΩ	10	
	Thermistor RT12 (at 25°C)	kΩ	10	
Outdoor model			MU-C18TV	MU-C24TV
Capacity	Air flow	m <sup>3</sup> /h	2,370	2,322
Electrical data	Compressor motor current	A	8.66	11.86
	Fan motor current	A	0.39	0.55
Compressor	Model		PE-33VPEHT	NE-47VMHHT
	Output	W	1,500	2,200
	Winding resistance (at 20°C)	Ω	C-R1.08 C-S 2.18	C-R0.67 C-S 2.02
Fan motor	Model		RA6V50-OG	RA6V60-AC
	Winding resistance (at 20°C)	Ω	WHT-BLK116.4 BLK-RED111.0	WHT-BLK81.1 BLK-RED102.2 BLK-YLW 92.2
Dimensions W×H×D		mm	850×605×290	
Weight		kg	48	61
Special remarks	Sound level (High)	dB	52	53
	Fan speed (High)	rpm	845	873
	Fan speed regulator		1 2	
	Refrigerant filling capacity (R407C)	kg	1.10	1.85
	Refrigerating oil (Model)	cc	1,100 (NEO22)	1,400 (NEO22)

**NOTE:** Test conditions are based on JIS C 9612.

Cooling : Indoor Dry-bulb temperature27°C / Wet-bulb temperature19°C  
Outdoor Dry-bulb temperature35°C / Wet-bulb temperature24°C

## B.1.1.2 Heat Pump

Indoor model			MSC-C07TV		MSC-C09TV		MSC-C12TV		
Function			Cooling	Heating	Cooling	Heating	Cooling	Heating	
Indoor unit power supply			Single phase, 230V, 50Hz						
Capacity	Air flow (High)	m <sup>3</sup> /h	474	504	474	504	588	576	
Electrical data	Power outlet	A	10						
	Running current	A	0.17				0.19		
	Power input	W	35				40		
	Power factor	%	90				92		
	Starting current	A	—						
	Fan motor current	A	0.17				0.19		
Fan motor	Model		RC4V19-BA						
	Winding resistance (at 20°C)	Ω	WHT-BLK 292 BLK-RED 325						
Dimensions W×H×D		mm	850×278×191						
Weight		kg	9				10		
Air direction			5						
Special remarks	Sound level (High)	dB	36	35	36	35	39	39	
	Fan speed (High)	rpm	950	1,000	950	1,000	1,020	1,000	
	Fan speed regulator			3					
	Thermistor RT11 (at 25°C)		kΩ	10					
	Thermistor RT12 (at 25°C)		kΩ	10					
Outdoor model			MUH-C07TV		MUH-C09TV		MUH-C12TV		
Outdoor unit power supply			Single phase, 230V, 50Hz						
Capacity	Capacity	kW	2.2	2.5	2.55	3.2	3.45	4.2	
	Dehumidification	ℓ/h	0.7	—	1.0	—	1.5	—	
	Outdoor air flow	m <sup>3</sup> /h	1,686			1,914			
Electrical data	Power outlet	A	10						
	Running current	A	3.23	2.93	3.83	4.13	5.71	6.01	
	Power input	W	735	675	875	925	1,240	1,310	
	Auxiliary heater	A (kW)	—						
	Power factor	%	99		99	97	94	95	
	Starting current	A	18		22		34		
	Compressor motor current	A	2.95	2.65	3.46	3.76	5.34	5.64	
	Fan motor current	A	0.29		0.37				
Coefficient of performance (C.O.P)			2.86	3.52	2.80	3.33	2.70	3.11	
Compressor	Model		RE-135VGSHT		RE-174VGSHT		RE-231VHSHT		
	Output	W	650		800		1,100		
	Winding resistance (at 20°C)	Ω	C-R 4.18 C-S 5.76		C-R 3.30 C-S 5.80		C-R 2.25 C-S 4.07		
Fan motor	Model		RA6V23-EA		RA6V33-CA				
	Winding resistance (at 20°C)	Ω	WHT-BLK 258 BLK-RED 385		WHT-BLK 176 BLK-RED 413				
Dimensions W×H×D		mm	780×540×255						
Weight		kg	34		36		39		
Special remarks	Sound level	dB	47		49				
	Fan speed	rpm	645		720				
	Fan speed regulator			1					
	Refrigerant filling capacity (R407C)	kg	0.90		1.00		1.25		
	Refrigerating oil (Model)	cc	350 (NEO22)				620 (NEO22)		
Thermistor RT61 (at 0°C)		kΩ	33.18						

**NOTE:** Test conditions are based on JIS C 9612.

Cooling : Indoor Dry-bulb temperature 27°C / Wet-bulb temperature 19°C

Outdoor Dry-bulb temperature 35°C / Wet-bulb temperature 24°C

Heating : Indoor Dry-bulb temperature 20°C

Outdoor Dry-bulb temperature 7°C / Wet-bulb temperature 6°C

Indoor model			MSH-C18TV		MSH-C24TV	
Function			Cooling	Heating	Cooling	Heating
Power supply			Single phase, 230V, 50Hz			
Capacity	Capacity	kW	5.2	6.0	6.3	7.5
	Dehumidification	ℓ/h	2.4	—	3.0	—
	Air flow (High)	m³/h	756		816	
Electrical data	Power outlet	A	15		25	
	Running current	A	9.4	9.7	12.8	13.7
	Power input	W	2,110	2,180	2,850	3,020
	Auxiliary heater	A (kW)	—			
	Power factor	%	98		97	96
	Starting current	A	55		83	
	Fan motor current	A	0.25		0.29	
	Coefficient of performance (C.O.P)			2.46	2.75	2.21
Fan motor	Model		RA4V27-EF		RA4V27-EE	
	Winding resistance (at 20°C)	Ω	WHT-BLK183.8 BLK-RED250.5			
Dimensions W×H×D		mm	1,015×320×190			
Weight		kg	14			
Special remarks	Air direction		5			
	Sound level (High)	dB	42		45	
	Fan speed (High)	rpm	1,180		1,260	
	Fan speed regulator		3			
	Thermistor RT11 (at 25°C)	kΩ	10			
	Thermistor RT12 (at 25°C)	kΩ	10			
Outdoor model			MUH-C18TV		MUH-C24TV	
Capacity	Air flow	m³/h	2,196		2,700	
Electrical data	Compressor motor current	A	8.76	9.06	11.93	12.87
	Fan motor current	A	0.39		0.58	
Compressor	Model		PE-36VPEHT		NE-47VMHHT	
	Output	W	1,600		2,200	
	Winding resistance (at 20°C)	Ω	C-R1.06 C-S2.03		C-R0.67 C-S2.02	
Fan motor	Model		RA6V50-OG		RA6V85-AA	
	Winding resistance (at 20°C)	Ω	WHT-BLK116.4 BLK-RED111.0		WHT-BLK62.7 BLK-YLW30.2 YLW-RED62.9	
Dimensions W×H×D		mm	850×605×290		870×850×295	
Weight		kg	54		71	
Special remarks	Sound level (High)	dB	52		53	
	Fan speed (High)	rpm	828		735	
	Fan speed regulator		1		2	
	Refrigerant filling capacity (R407C)	kg	1.60		2.00	
	Refrigerant oil (Model)	cc	1,100 (NEO22)		1,400 (NEO22)	
	Thermistor RT61 (at 0°C)	kΩ	33.18			
	Thermistor RT63 (at 0°C)	kΩ	—		33.18	

NOTE: Test conditions are based on JIS C 9612.

Cooling : Indoor Dry-bulb temperature 27°C / Wet-bulb temperature 19°C  
 Outdoor Dry-bulb temperature 35°C / Wet-bulb temperature (24°C)  
 Heating : Indoor Dry-bulb temperature 20°C / Wet-bulb temperature —  
 Outdoor Dry-bulb temperature 7°C / Wet-bulb temperature 6°C

## B.1.2 OUTLINES AND DIMENSIONS

### B.1.2.1 Cool Only

MSC-C07TV  
MSC-C09TV

Unit: mm

**INDOOR UNIT**

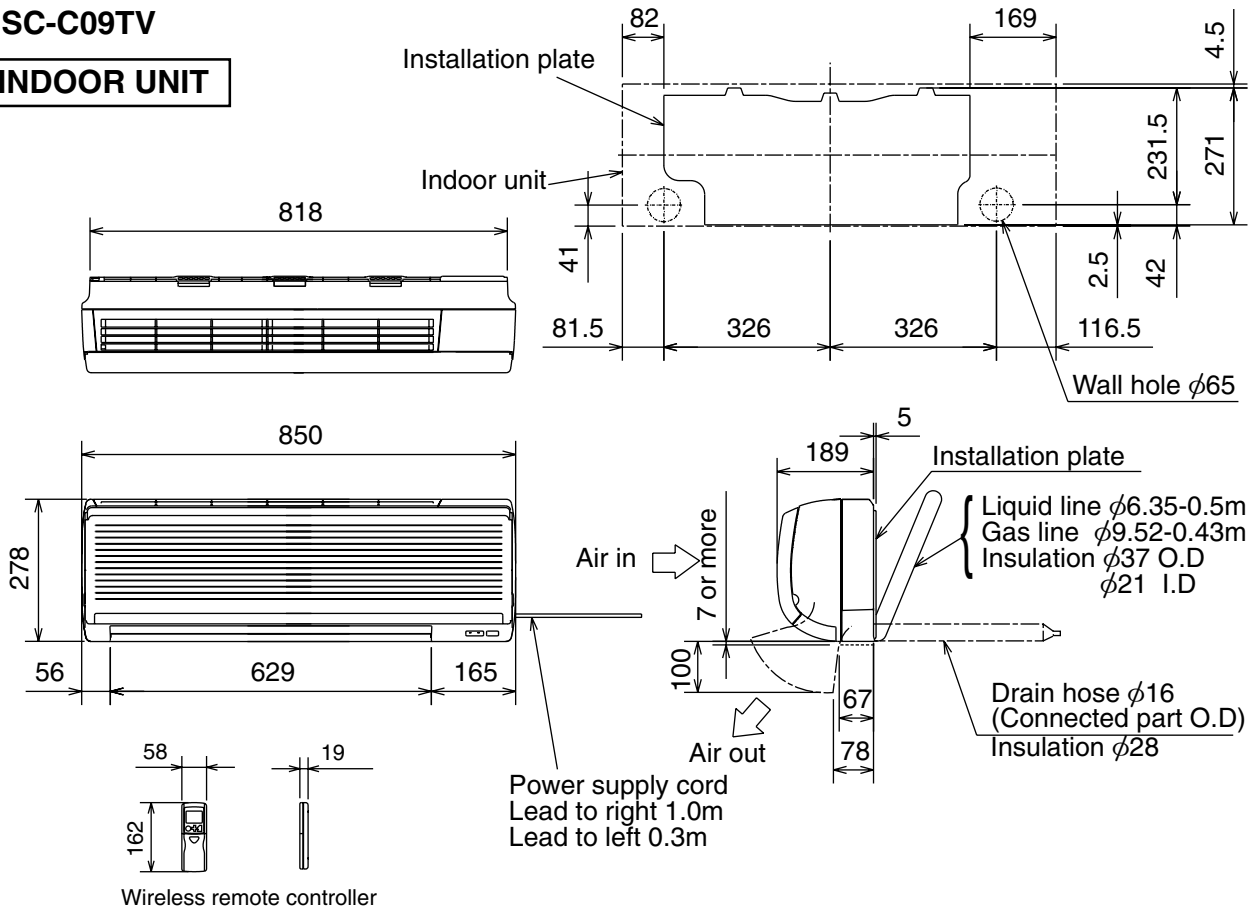

MSC-C12TV

**INDOOR UNIT**

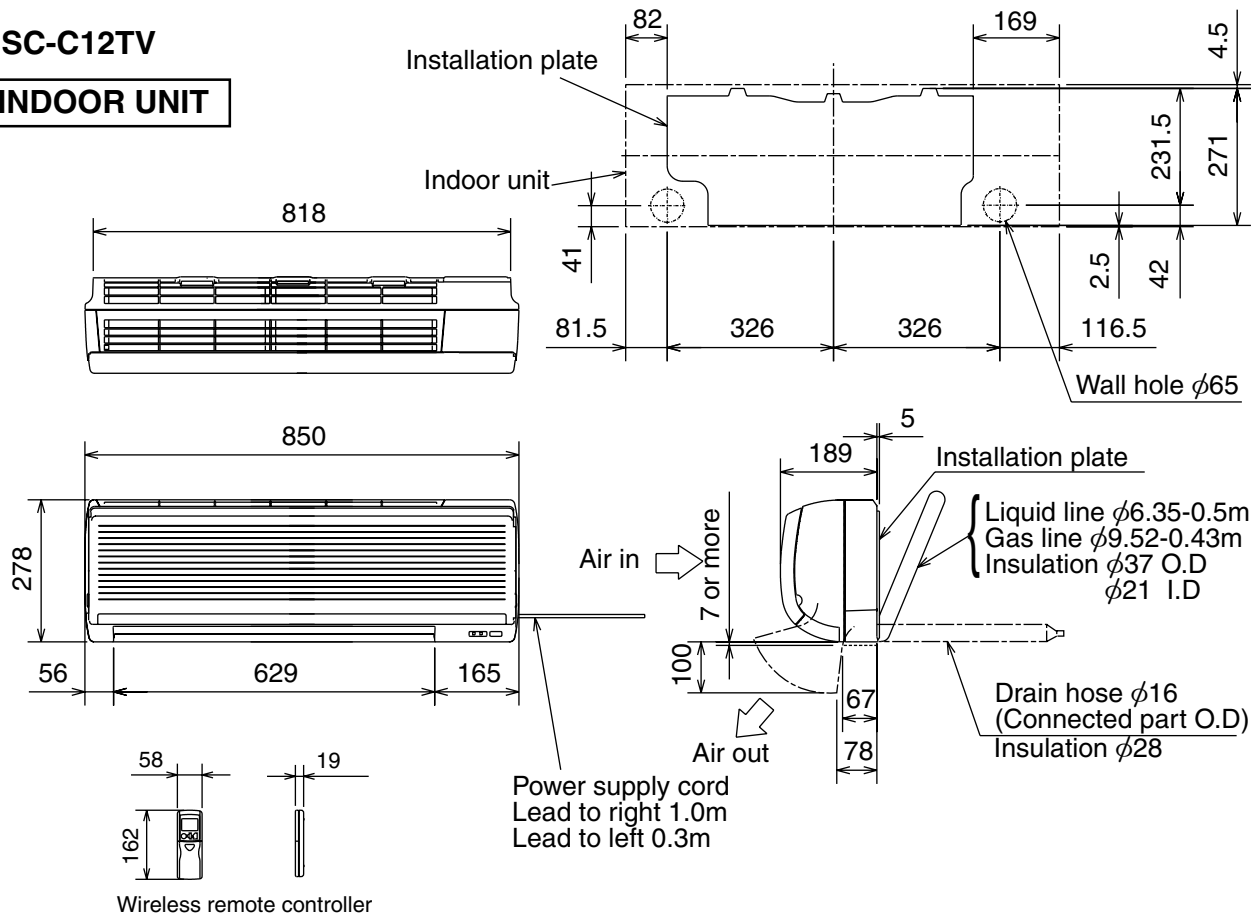

OUTLINES AND DIMENSIONS

WALL-MOUNTED

MU-C07TV  
 MU-C09TV  
 MU-C12TV

**OUTDOOR UNIT**

Unit: mm

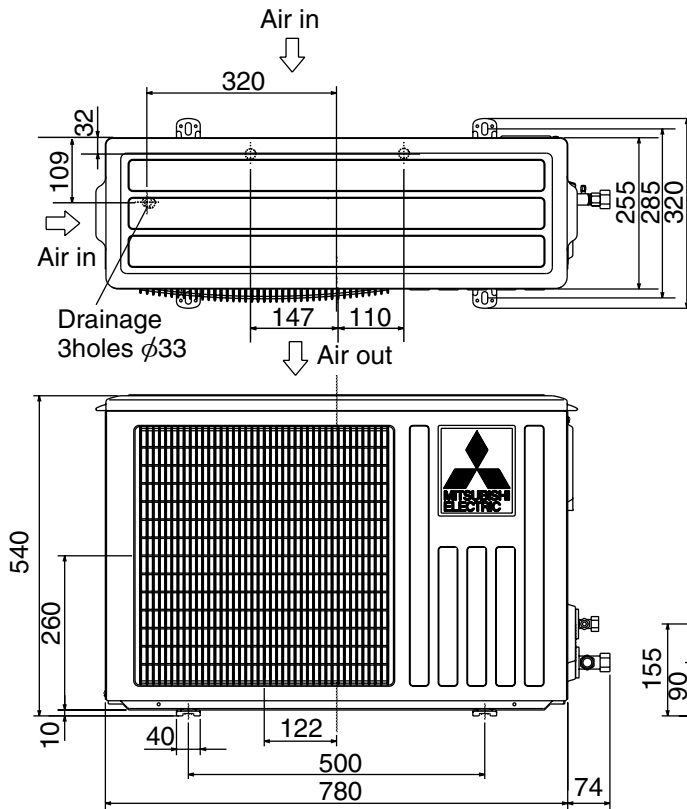

**REQUIRED SPACE**

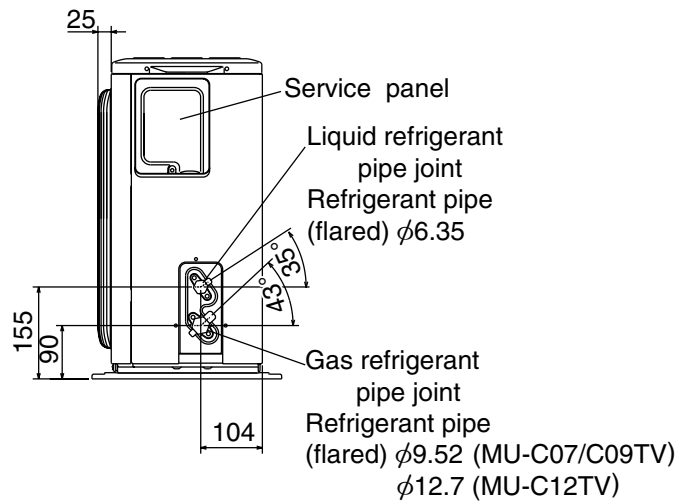
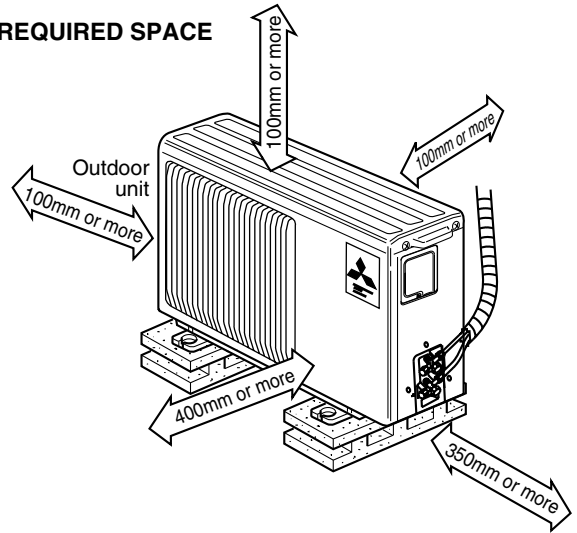

**MS-C18TV  
MS-C24TV**

Unit: mm

**INDOOR UNIT**

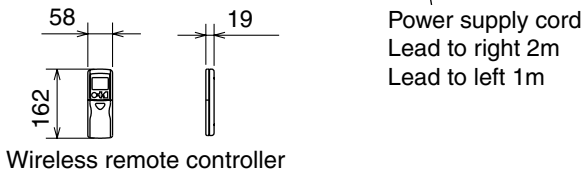
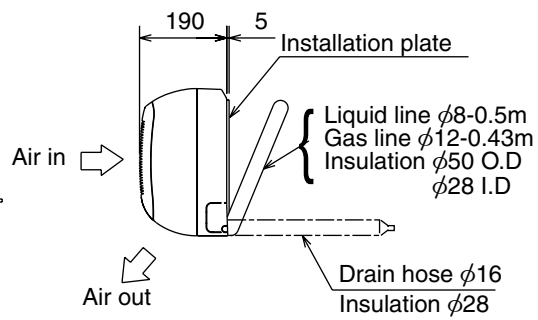
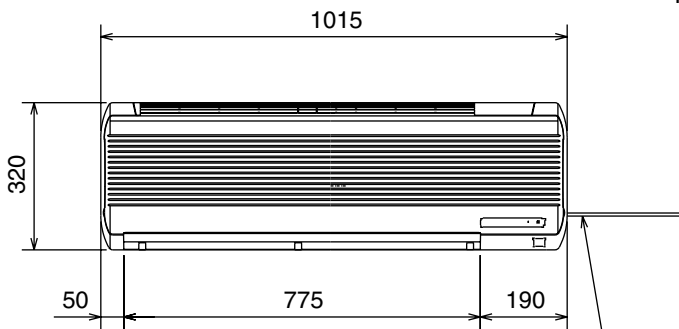
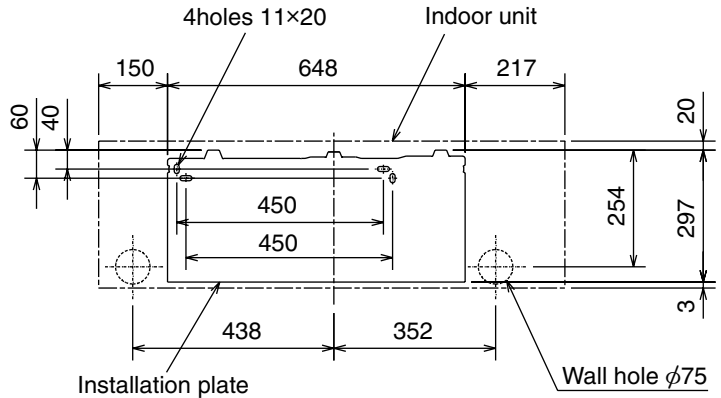
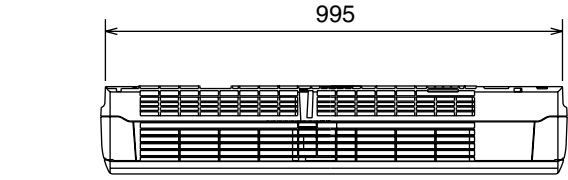

**MU-C18TV  
MU-C24TV**

**OUTDOOR UNIT**

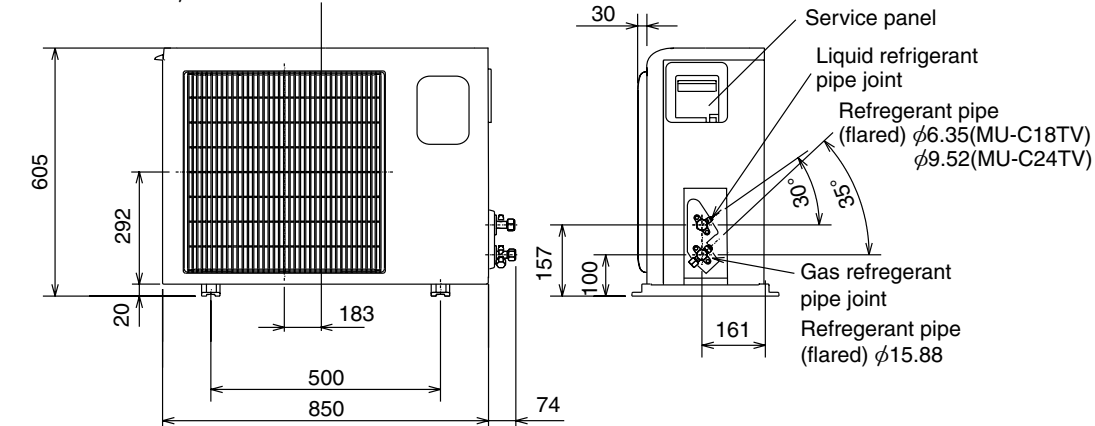
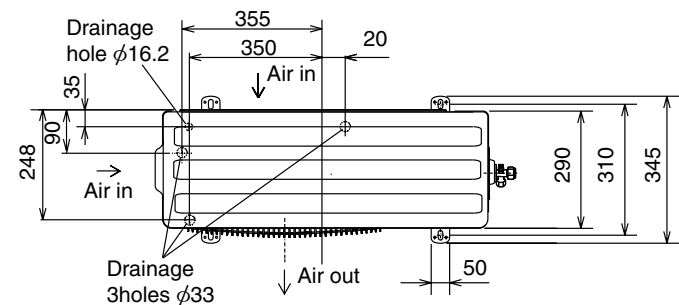
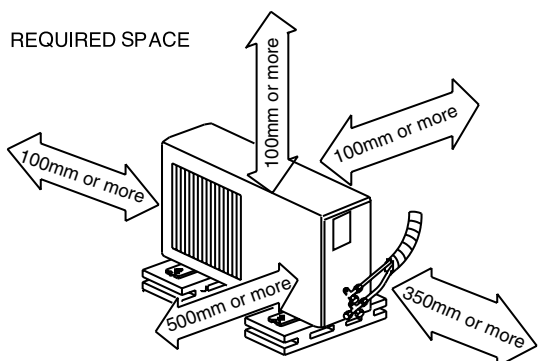

OUTLINES AND DIMENSIONS WALL-MOUNTED



B.1.2.2 Heat Pump

MUH-C07TV  
 MUH-C09TV  
 MUH-C12TV

**OUTDOOR UNIT**

Unit: mm

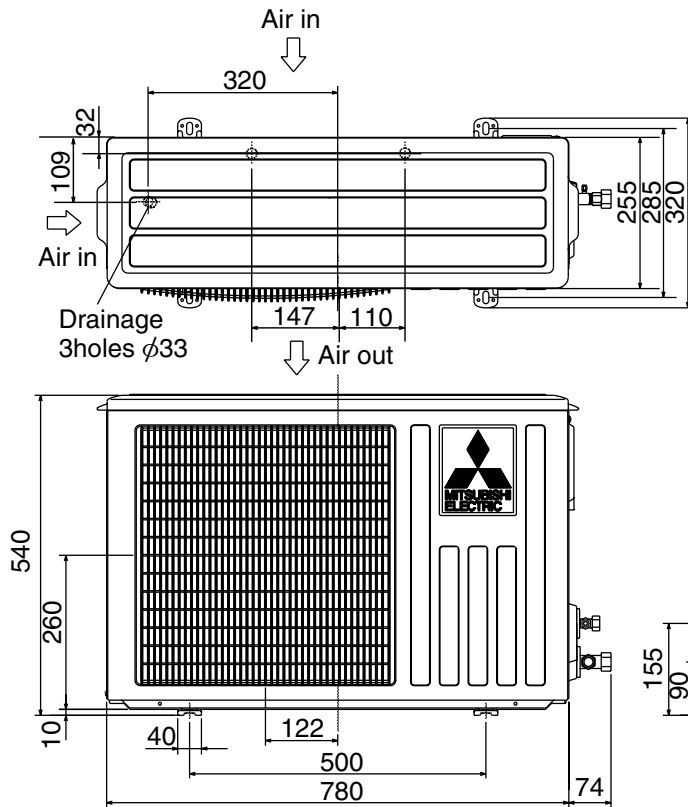

**REQUIRED SPACE**

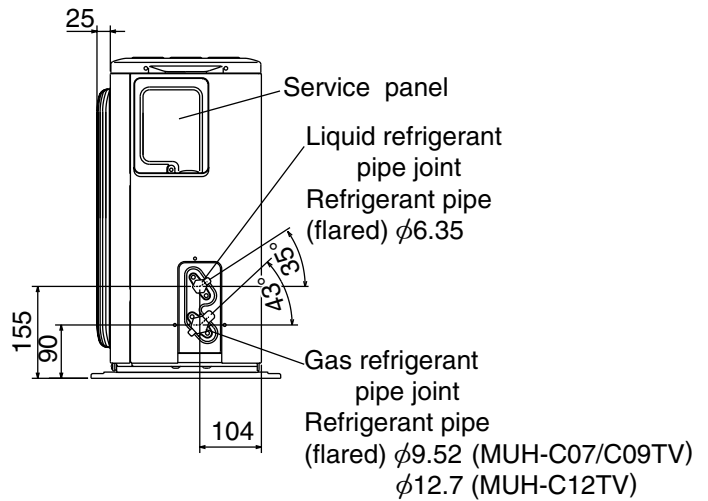
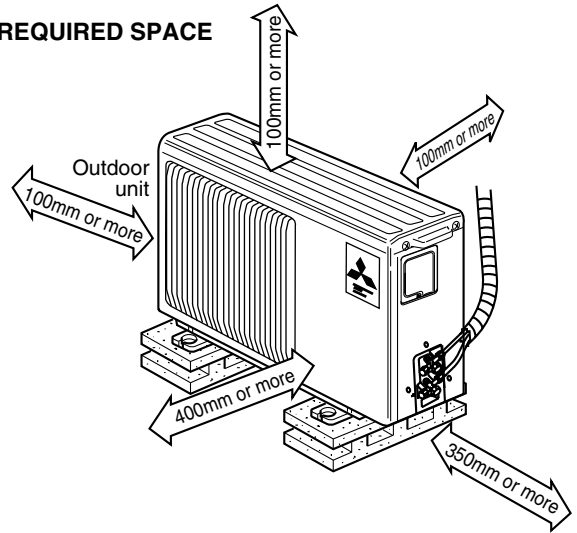

**MSH-C18TV  
MSH-C24TV**

Unit: mm

**INDOOR UNIT**

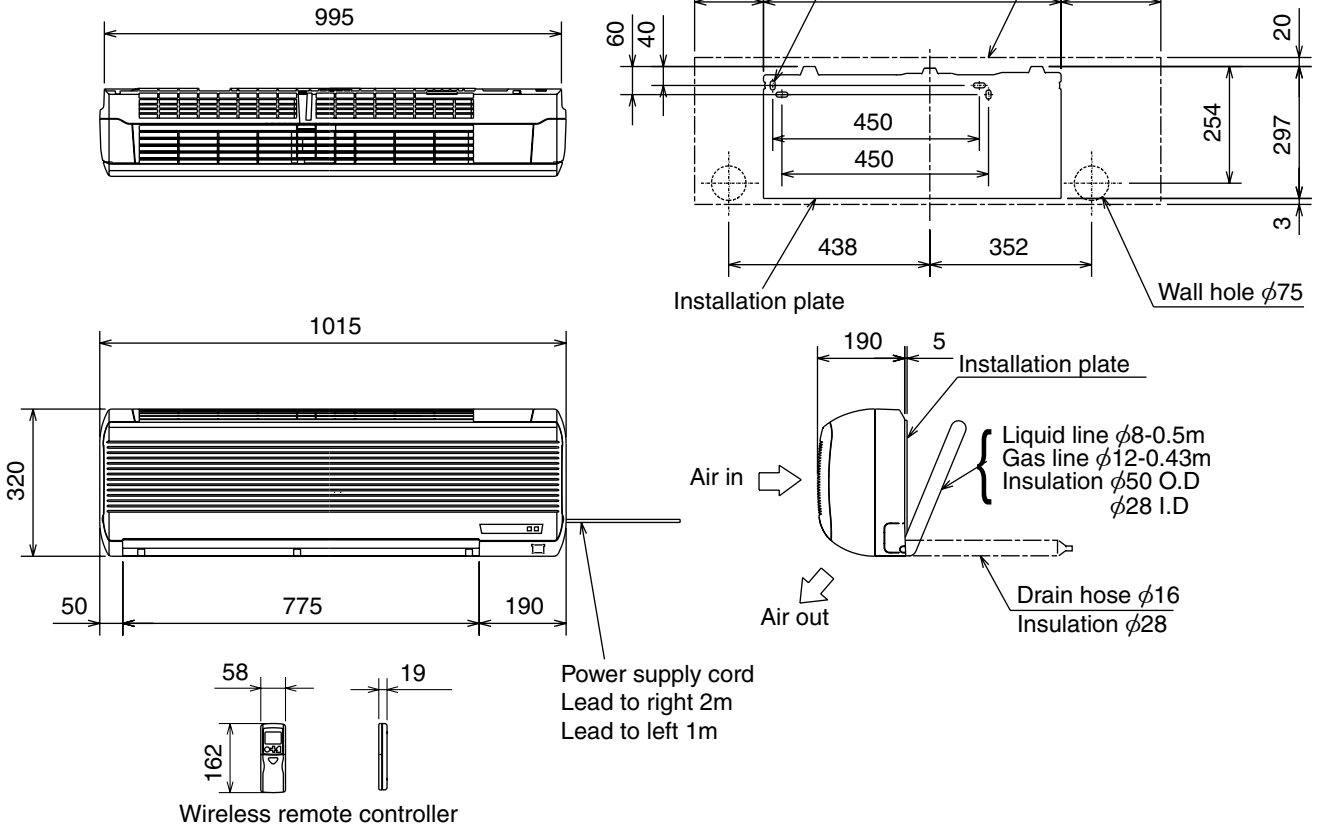

**MUH-C18TV**

**OUTDOOR UNIT**

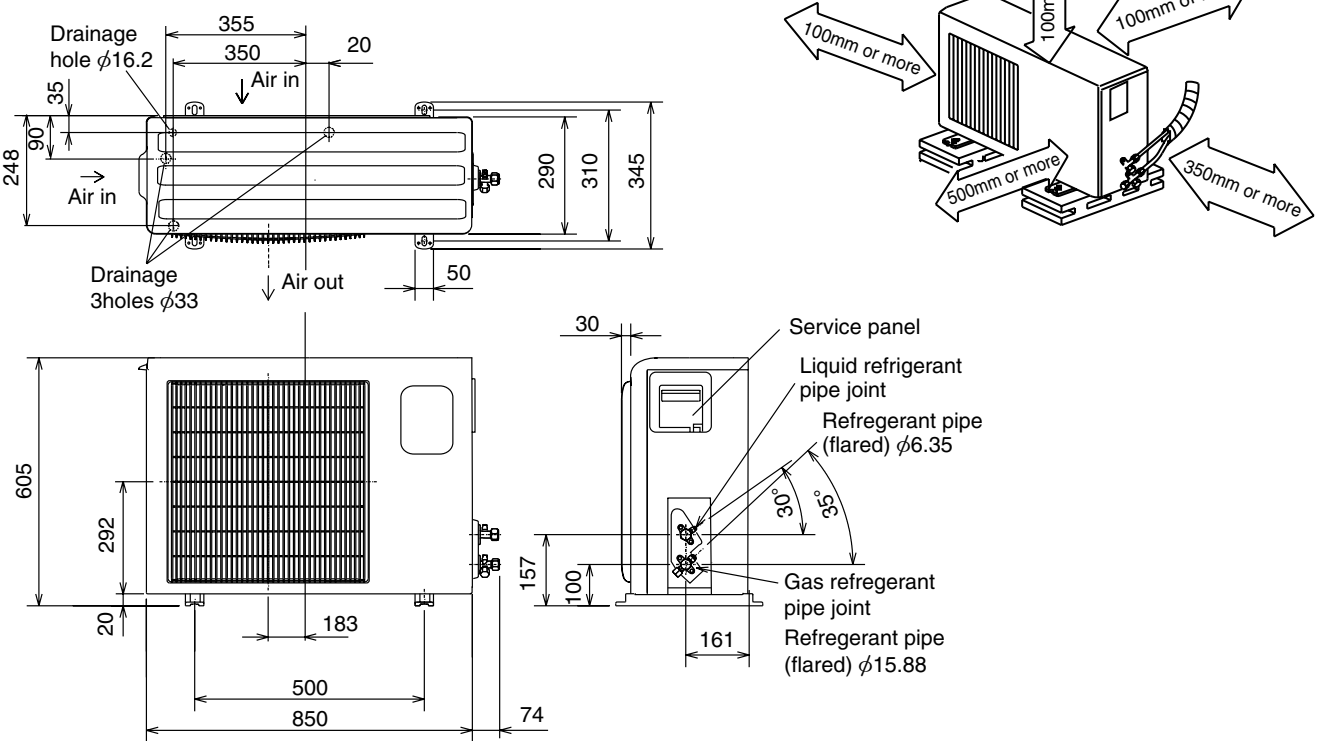

OUTLINES AND DIMENSIONS

WALL-MOUNTED

MUH-C24TV

Unit: mm

**OUTDOOR UNIT**

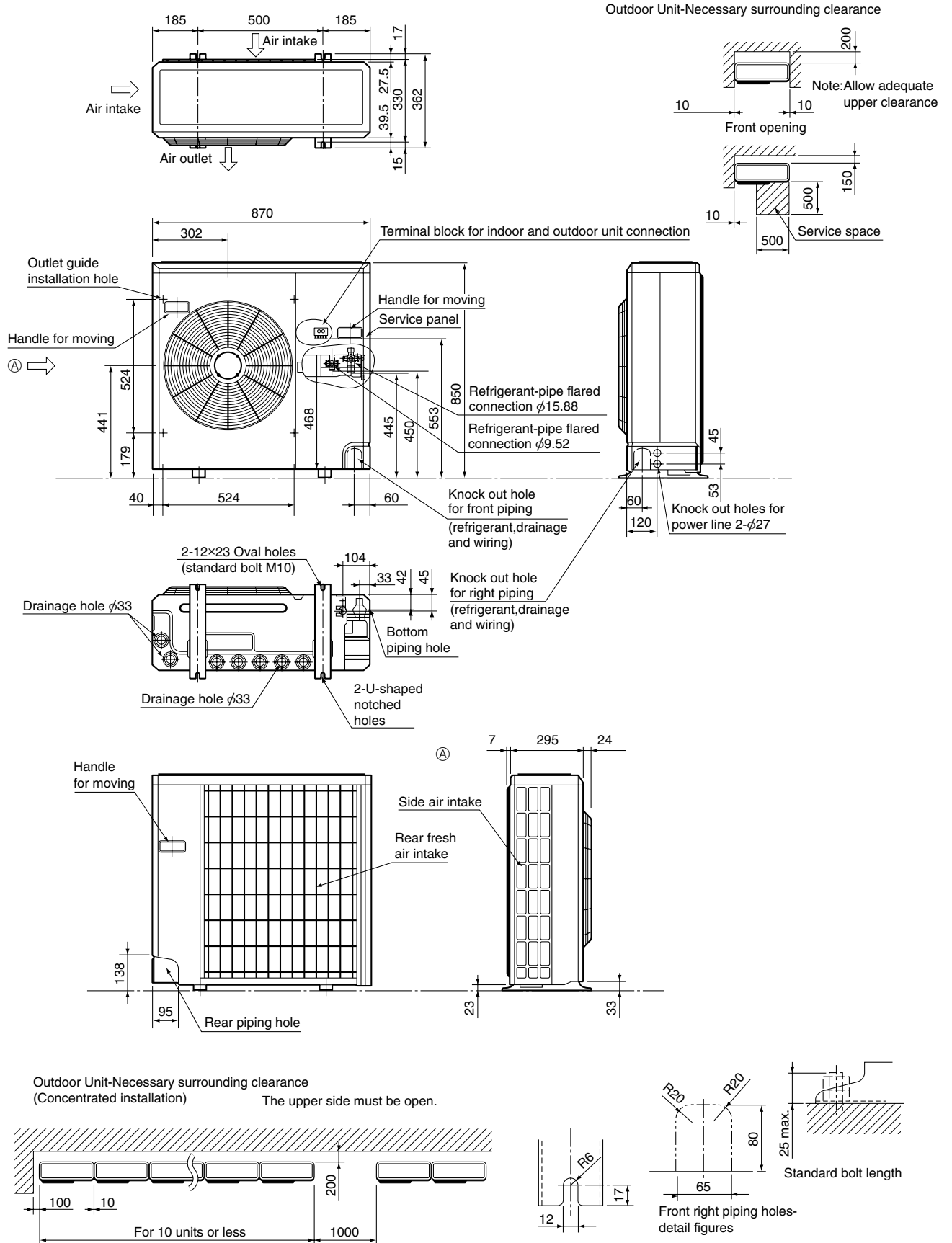

### B.1.3 WIRING DIAGRAM

#### B.1.3.1 Cool Only

#### MSC-C07TV, MSC-C09TV, MSC-C12TV

#### INDOOR UNIT

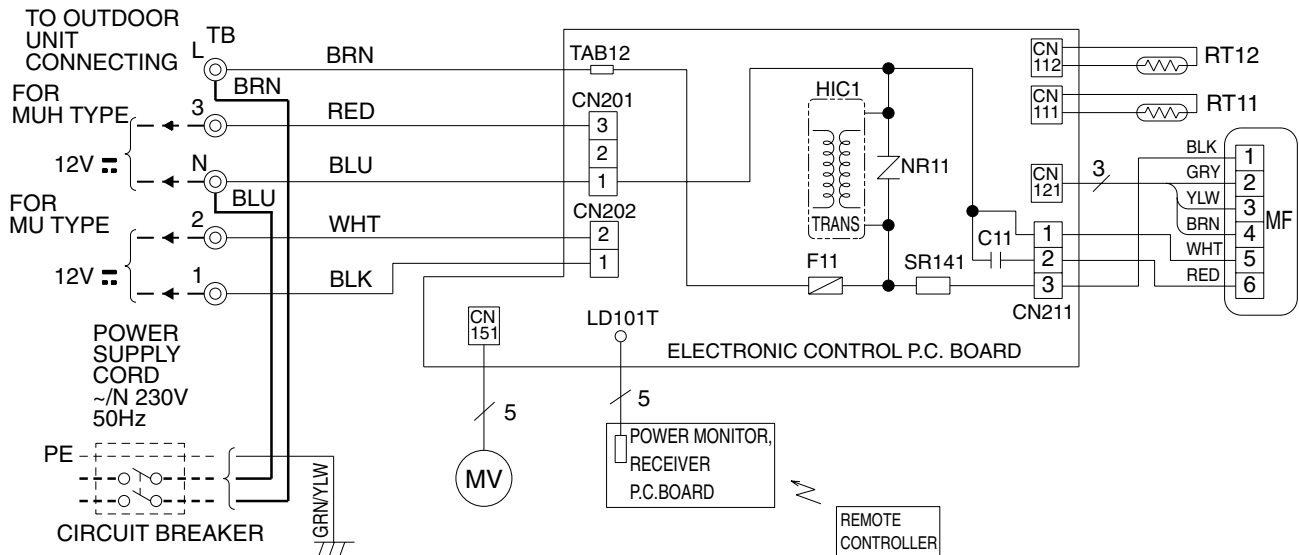

SYMBOL	NAME	SYMBOL	NAME	SYMBOL	NAME
C11	INDOOR FAN CAPACITOR	MV	VANE MOTOR	SR141	SOLID STATE RELAY
F11	FUSE(3.15A)	NR11	VARISTOR	TB	TERMINAL BLOCK
HIC1	DC/DC CONVERTER	RT11	ROOM TEMPERATURE THERMISTOR		
MF	INDOOR FAN MOTOR(INNER FUSE)	RT12	INDOOR COIL THERMISTOR		

- NOTE:** 1. About the outdoor side electric wiring refer to the outdoor unit electric wiring diagram for servicing.  
 2. Use copper conductors only. (For field wiring)  
 3. Symbols below indicate.  
 ◎: Terminal block, □□□□: Connector

SG79J047H01

#### MU-C07TV, MU-C09TV, MU-C12TV

#### OUTDOOR UNIT

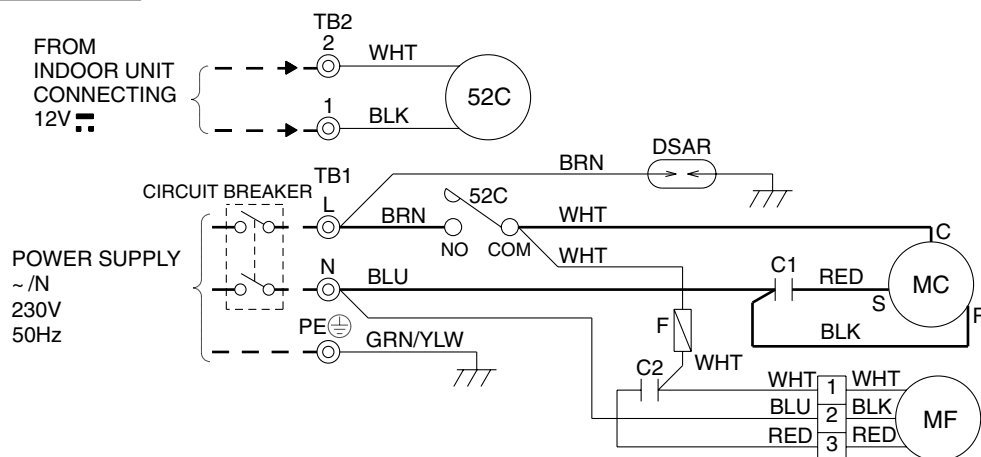

SYMBOL	NAME	SYMBOL	NAME	SYMBOL	NAME
C1	COMPRESSOR CAPACITOR	F	FUSE(2A)	TB1, TB2	TERMINAL BLOCK
C2	OUTDOOR FAN CAPACITOR	MC	COMPRESSOR(INNER PROTECTOR)	52C	CONTACTOR
DSAR	SURGE ABSORBER	MF	OUTDOOR FAN MOTOR(INNER PROTECTOR)		

- NOTE:** 1. About the indoor side electric wiring refer to the indoor unit electric wiring diagram for servicing.  
 2. Use copper conductors only. (For field wiring)  
 3. Symbols below indicate.  
 ◎: Terminal block, □□□□: Connector

VG79B057H01

MS-C18TV

INDOOR UNIT

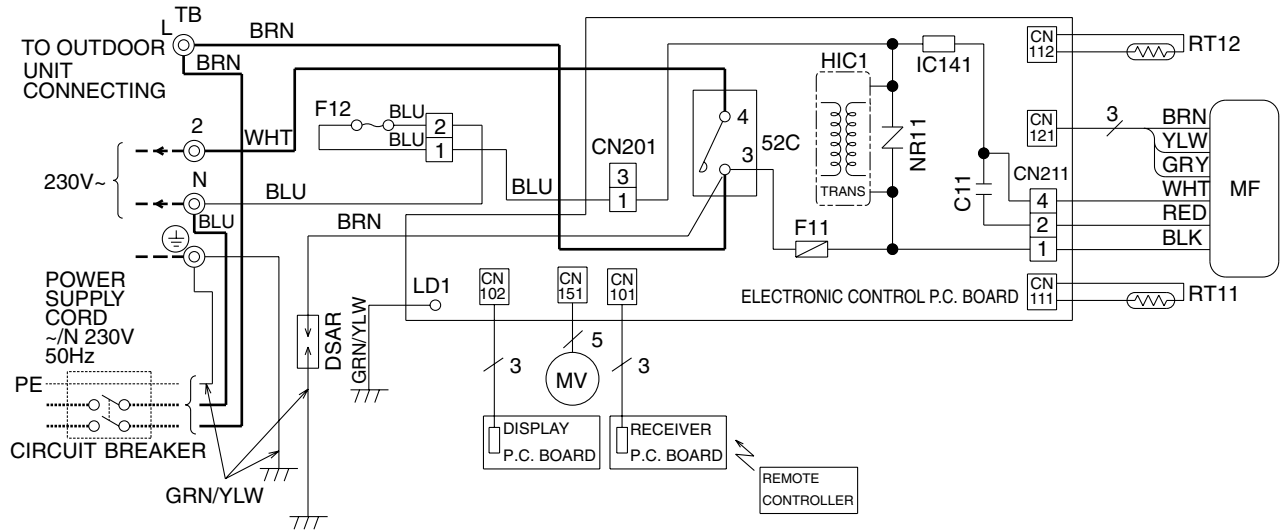

SYMBOL	NAME	SYMBOL	NAME	SYMBOL	NAME
C11	INDOOR FAN CAPACITOR	IC141	HYBRID IC	RT12	INDOOR COIL THERMISTOR
DSAR	SURGE ABSORBER	MF	INDOOR FAN MOTOR(INNER FUSE)	TB	TERMINAL BLOCK
F11	FUSE(3.15A)	MV	VANE MOTOR	52C	CONTACTOR
F12	THERMAL FUSE(93°C)	NR11	VARISTOR		
HIC1	DC/DC CONVERTER	RT11	ROOM TEMPERATURE THERMISTOR		

- NOTE:** 1. About the outdoor side electric wiring refer to the outdoor unit electric wiring diagram for servicing.  
 2. Use copper conductors only.(For field wiring)  
 3. Symbols below indicate.  
 ◎: Terminal block, □□□□: Connector

VG79B066H01

MU-C18TV

OUTDOOR UNIT

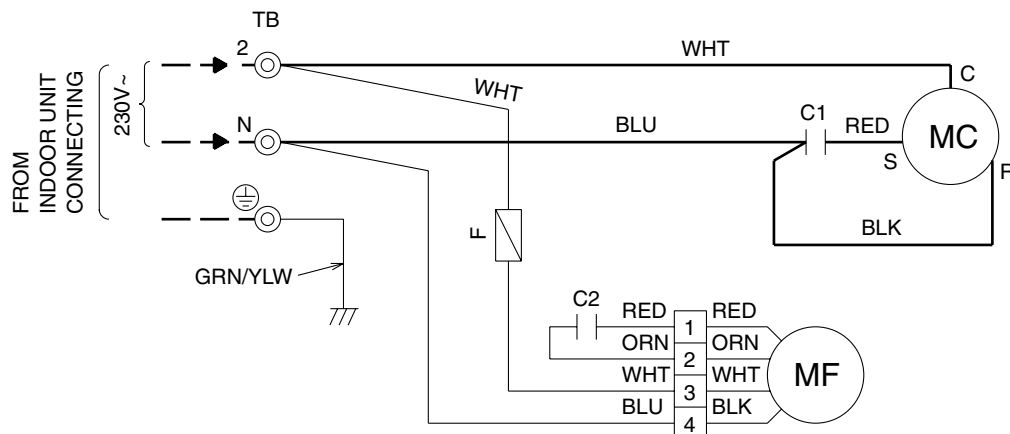

SYMBOL	NAME	SYMBOL	NAME	SYMBOL	NAME
C1	COMPRESSOR CAPACITOR	F	FUSE(2A)	MF	OUTDOOR FAN MOTOR(INNER PROTECTOR)
C2	OUTDOOR FAN CAPACITOR	MC	COMPRESSOR(INNER PROTECTOR)	TB	TERMINAL BLOCK

- NOTE:** 1. About the indoor side electric wiring refer to the indoor unit electric wiring diagram for servicing.  
 2. Use copper conductors only.(For field wiring)  
 3. Symbols below indicate.  
 ◎: Terminal block, □□□□: Connector

SG79B965H01

WALL-MOUNTED WIRING DIAGRAM

MS-C24TV

INDOOR UNIT

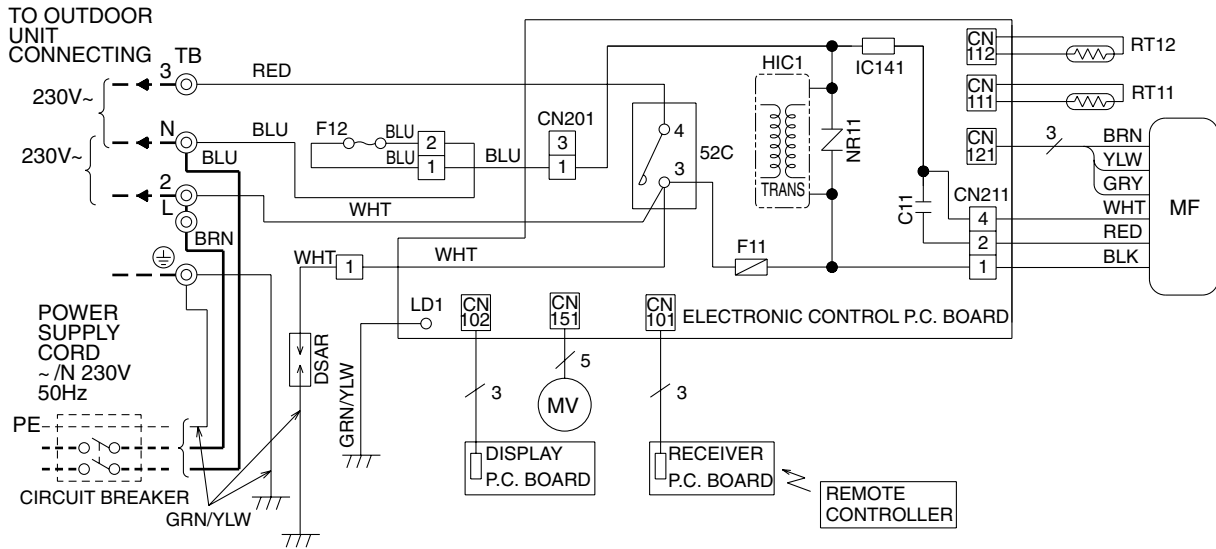

SYMBOL	NAME	SYMBOL	NAME	SYMBOL	NAME
C11	INDOOR FAN CAPACITOR	IC141	HYBRID IC	RT12	INDOOR COIL THERMISTOR
DSAR	SURGE ABSORBER	MF	INDOOR FAN MOTOR(INNER FUSE)	TB	TERMINAL BLOCK
F11	FUSE(3.15A)	MV	VANE MOTOR	52C	CONTACTOR
F12	THERMINAL FUSE(93°C)	NR11	VARISTOR		
HIC1	DC/DC CONVERTER	RT11	ROOM TEMPERATURE THERMISTOR		

VG79B067H01

- NOTE:** 1. About the outdoor side electric wiring refer to the outdoor unit electric wiring diagram for servicing.  
 2. Use copper conductors only.(For field wiring)  
 3. Symbols below indicate.  
 ○: Terminal block, □□□□: Connector

MU-C24TV

OUTDOOR UNIT

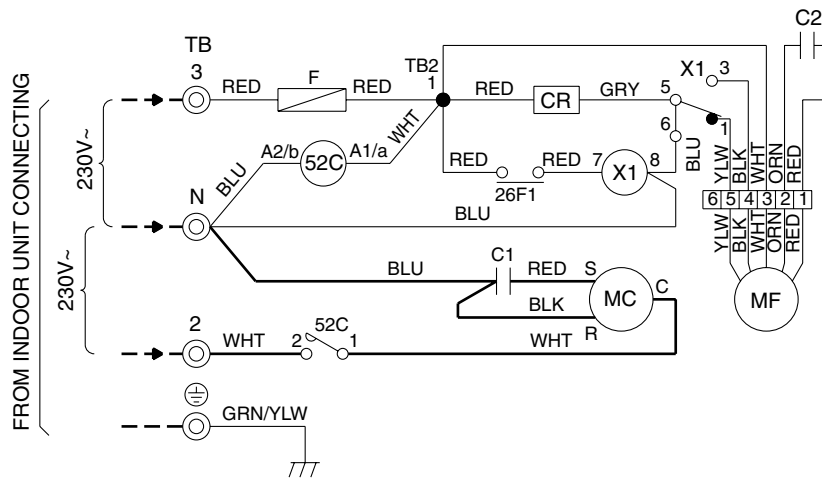

SYMBOL	NAME	SYMBOL	NAME	SYMBOL	NAME
CR	CR SURGE ABSORBER	MC	COMPRESSOR (INNER PROTECTOR)	X1	FAN MOTOR RELAY
C1	COMPRESSOR CAPACITOR	MF	OUTDOOR FAN MOTOR(INNER PROTECTOR)	26F1	THERMOSTAT(AIR FLOW CONTROL)
C2	OUTDOOR FAN CAPACITOR	TB	TERMINAL BLOCK	52C	COMPRESSOR CONTACTOR
F	FUSE(2A)	TB2	TERMINAL BLOCK		

SG79B964H01

- NOTE:** 1. About the indoor side electric wiring refer to the indoor unit electric wiring diagram for servicing.  
 2. Use copper conductors only.(For field wiring)  
 3. Symbols below indicate.  
 ○: Terminal block, □□□□: Connector

B.1.3.2 Heat Pump

MUH-C07TV, MUH-C09TV, MUH-C12TV

**OUTDOOR UNIT**

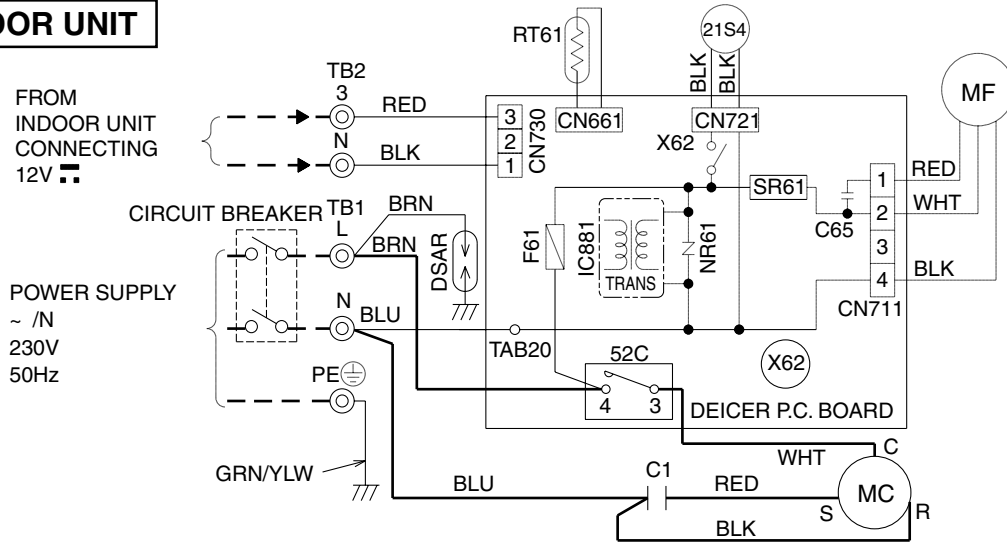

SYMBOL	NAME	SYMBOL	NAME	SYMBOL	NAME
C1	COMPRESSOR CAPACITOR	MC	COMPRESSOR(INNER PROTECTOR)	TB1,TB2	TERMINAL BLOCK
C65	OUTDOOR FAN CAPACITOR	MF	OUTDOOR FAN MOTOR(INNER PROTECTOR)	X62	R.V. COIL RELAY
DSAR	SURGE ABSORBER	NR61	VARISTOR	21S4	R.V. COIL
F61	FUSE(2A)	RT61	DEFROST THERMISTOR	52C	CONTACTOR
IC881	DC/DC CONVERTER	SR61	SOLID STATE RELAY		

- NOTE:** 1. About the indoor side electric wiring refer to the indoor unit electric wiring diagram for servicing.  
 2. Use copper conductors only. (For field wiring)  
 3. Symbols below indicate.  
 ◎: Terminal block, □□□□: Connector

VG79B058H01

MSH-C18TV

INDOOR UNIT

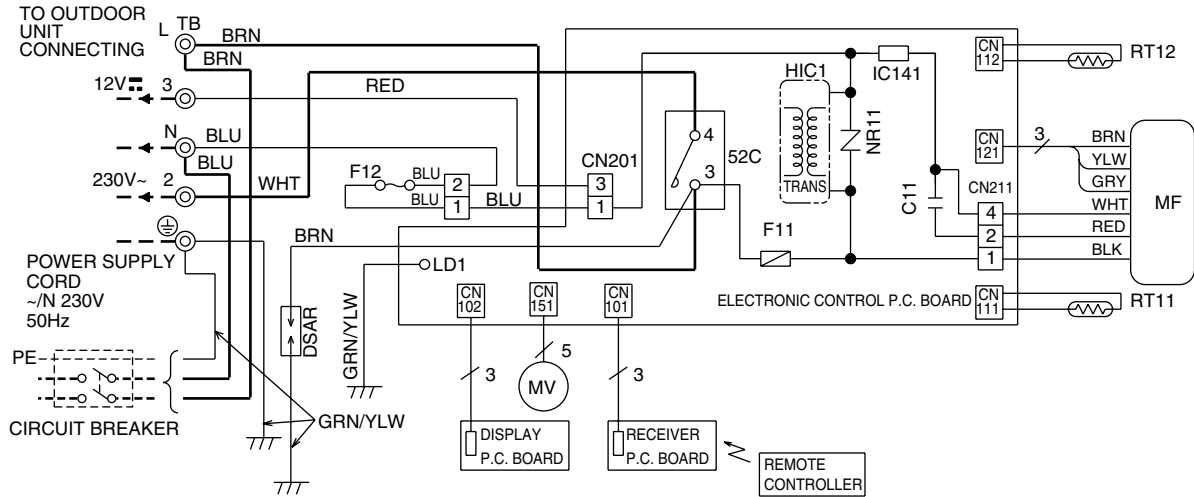

SYMBOL	NAME	SYMBOL	NAME	SYMBOL	NAME
C11	INDOOR FAN CAPACITOR	IC141	HYBRID IC	RT12	INDOOR COIL THERMISTOR
DSAR	SURGE ABSORBER	MF	INDOOR FAN MOTOR(INNER FUSE)	TB	TERMINAL BLOCK
F11	FUSE(3.15A)	MV	VANE MOTOR	52C	CONTACTOR
F12	THERMAL FUSE(93°C)	NR11	VARISTOR		
HIC1	DC/DC CONVERTER	RT11	ROOM TEMPERATURE THERMISTOR		

VG79B068H01

- NOTE:** 1. About the outdoor side electric wiring refer to the outdoor unit electric wiring diagram for servicing.  
 2. Use copper conductors only.(For field wiring)  
 3. Symbols below indicate.  
 ○: Terminal block, □□□□: Connector

MUH-C18TV

OUTDOOR UNIT

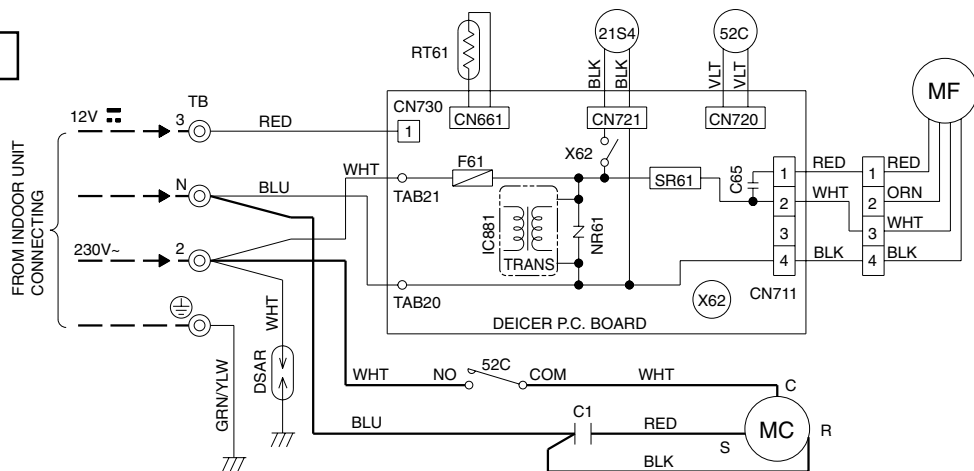

SYMBOL	NAME	SYMBOL	NAME	SYMBOL	NAME
C1	COMPRESSOR CAPACITOR	MC	COMPRESSOR(INNER PROTECTOR)	TB	TERMINAL BLOCK
C65	OUTDOOR FAN CAPACITOR	MF	OUTDOOR FAN MOTOR(INNER PROTECTOR)	X62	R.V. COIL COIL RELAY
DSAR	SURGE ABSORBER	NR61	VARISTOR	21S4	R.V. COIL
F61	FUSE(2A)	RT61	DEFROST THERMISTOR	52C	COMPRESSOR CONTACTOR
IC881	DC/DC CONVERTER	SR61	SOLID STATE RELAY		

SG79B966H01

- NOTE:** 1. About the indoor side electric wiring refer to the indoor unit electric wiring diagram for servicing.  
 2. Use copper conductors only.(For field wiring)  
 3. Symbols below indicate.  
 ○: Terminal block, □□□□: Connector



MSH-C24TV

INDOOR UNIT

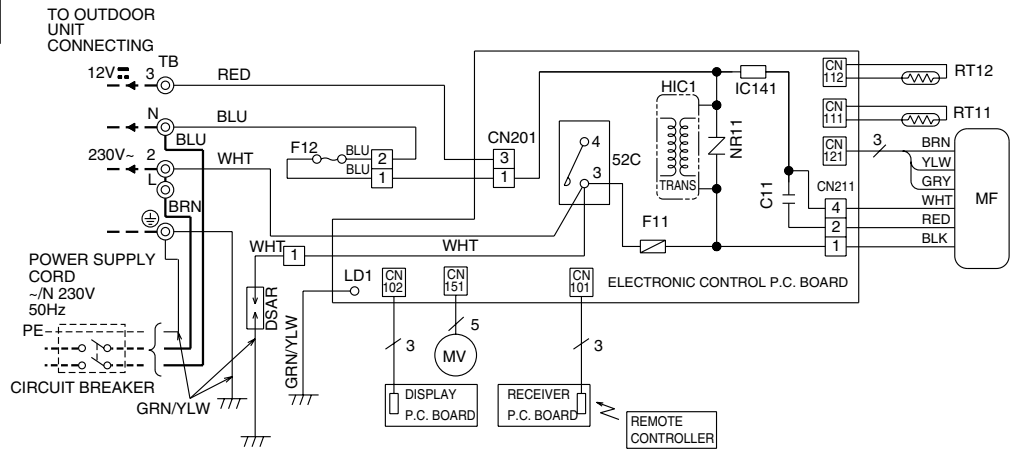

SYMBOL	NAME	SYMBOL	NAME	SYMBOL	NAME
C11	INDOOR FAN CAPACITOR	IC141	HYBRID IC	RT12	INDOOR COIL THERMISTOR
DSAR	SURGE ABSORBER	MF	INDOOR FAN MOTOR(INNER FUSE)	TB	TERMINAL BLOCK
F11	FUSE(3.15A)	MV	VANE MOTOR	52C	CONTACTOR
F12	THERMAL FUSE(93°C)	NR11	VARISTOR		
HIC1	DC/DC CONVERTER	RT11	ROOM TEMPERATURE THERMISTOR		

**NOTE:** 1. About the outdoor side electric wiring refer to the outdoor unit electric wiring diagram for servicing. VG79B069H01  
 2. Use copper conductors only.(For field wiring)  
 3. Symbols below indicate.  
 ○: Terminal block, □□□□: Connector

MUH-C24TV

OUTDOOR UNIT

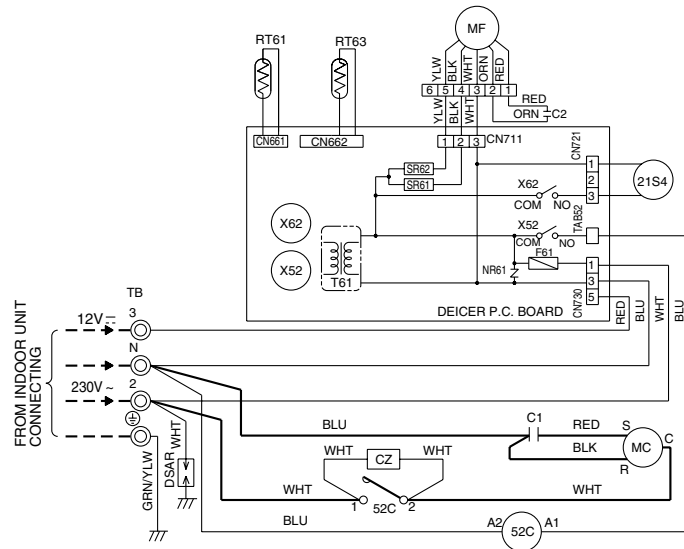

SYMBOL	NAME	SYMBOL	NAME	SYMBOL	NAME
CZ	CZ SURGE ABSORBER	NR61	VARISTOR	X52	CONTACTOR
C1	COMPRESSOR CAPACITOR	RT61	DEFROST THERMISTOR	X62	R.V. COIL RELAY
C2	OUTDOOR FAN CAPACITOR	RT63	AMBIENT TEMPERATURE THERMISTOR	21S4	R.V. COIL
DSAR	SURGE ABSORBER	SR61	SOLID STATE RELAY	52C	COMPRESSOR CONTACTOR
F61	FUSE(3.15A)	SR62	SOLID STATE RELAY		
MC	COMPRESSOR(INNER PROTECTOR)	TB	TERMINAL BLOCK		
MF	OUTDOOR FAN MOTOR(INNER PROTECTOR)	T61	TRANSFORMER		

**NOTE:** 1. Use copper conductors only.(For field wiring) SG79J155H01  
 2. Since the indoor and outdoor unit connecting wires have polarity, connect them according to the numbers(3, N, 2).  
 3. Symbols below indicate.  
 ○: Terminal block, □□□□: Connector

WALL-MOUNTED WIRING DIAGRAM

### B.1.4 REFRIGERANT SYSTEM DIAGRAM

#### B.1.4.1 Cool Only

MSC-C07TV  
MSC-C09TV

MU-C07TV  
MU-C09TV

Unit: mm

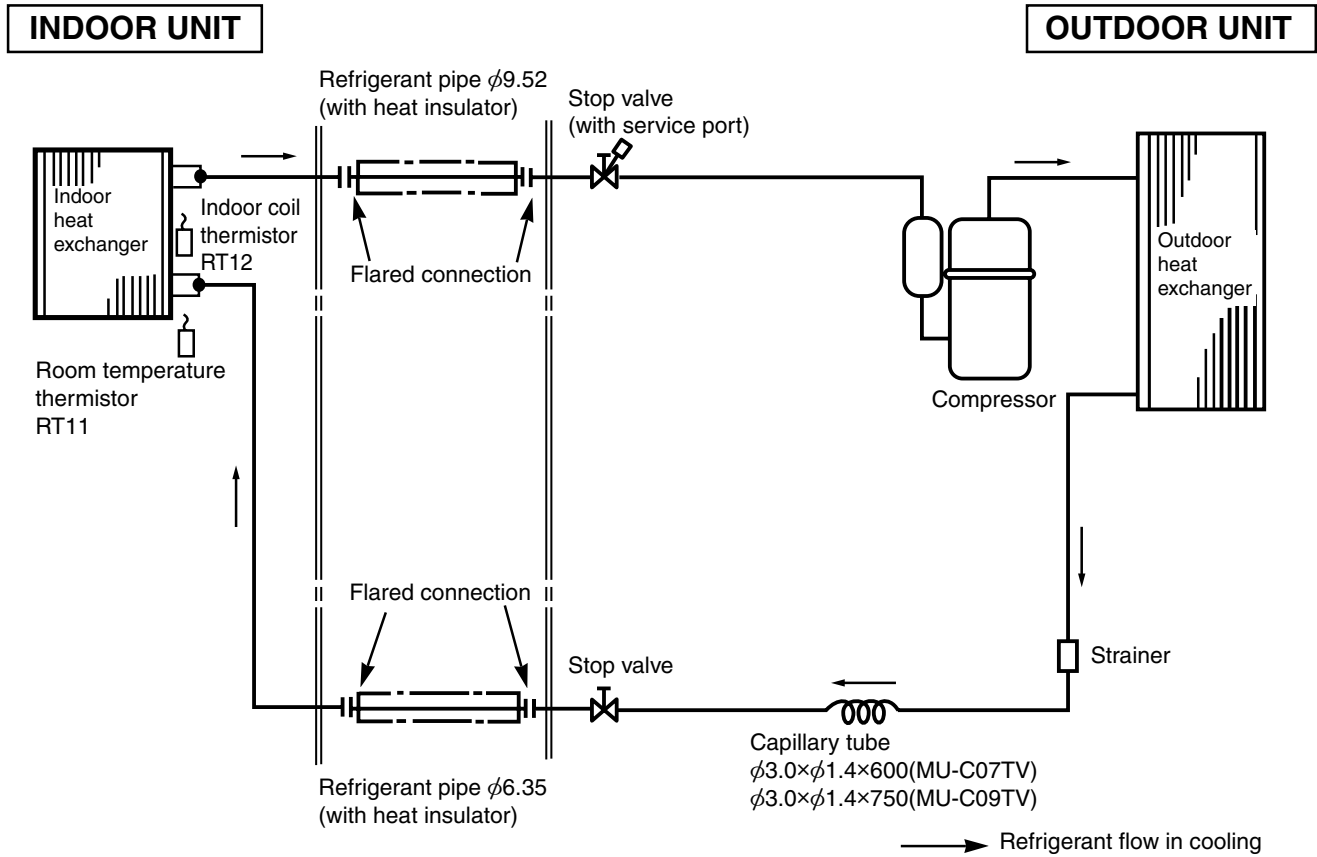

MSC-C12TV

MU-C12TV

Unit: mm

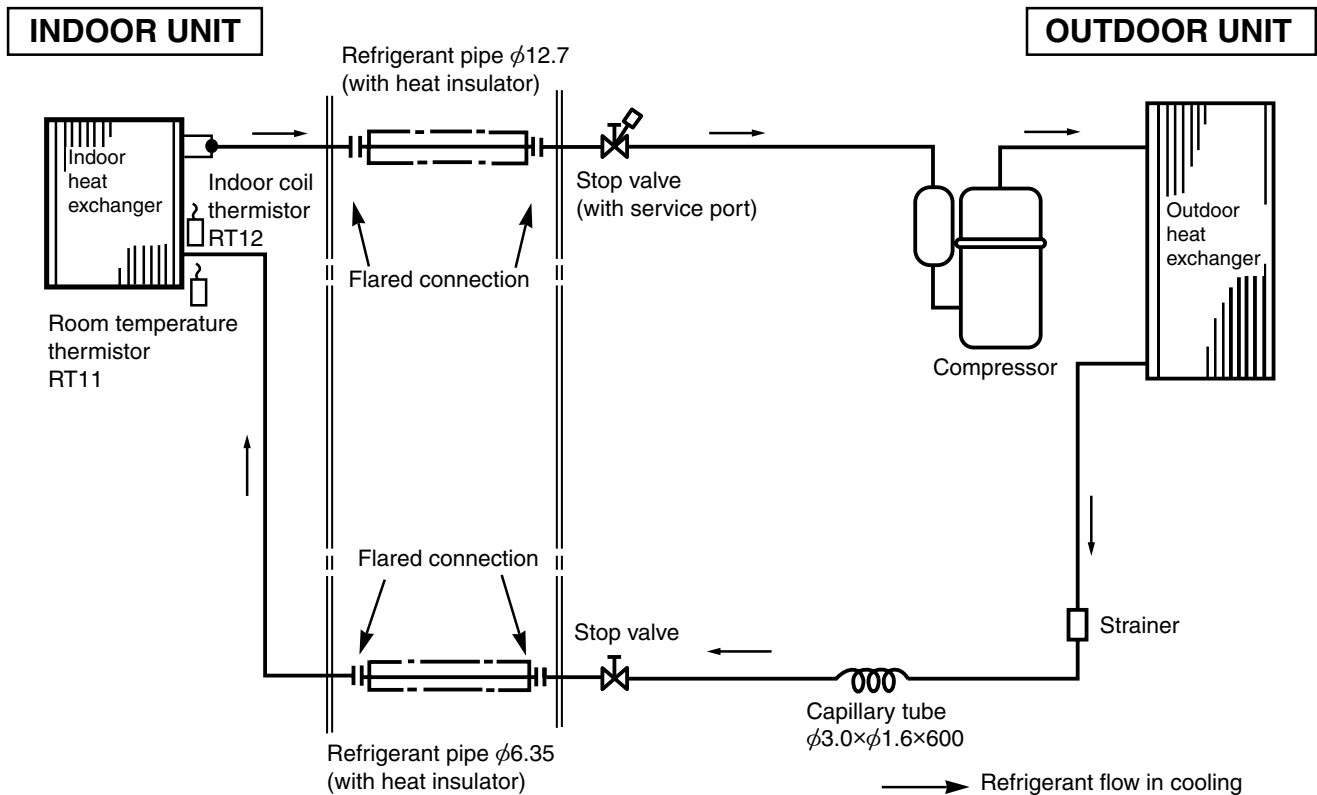

Unit: mm

MS-C18TV

MU-C18TV

INDOOR UNIT

OUTDOOR UNIT

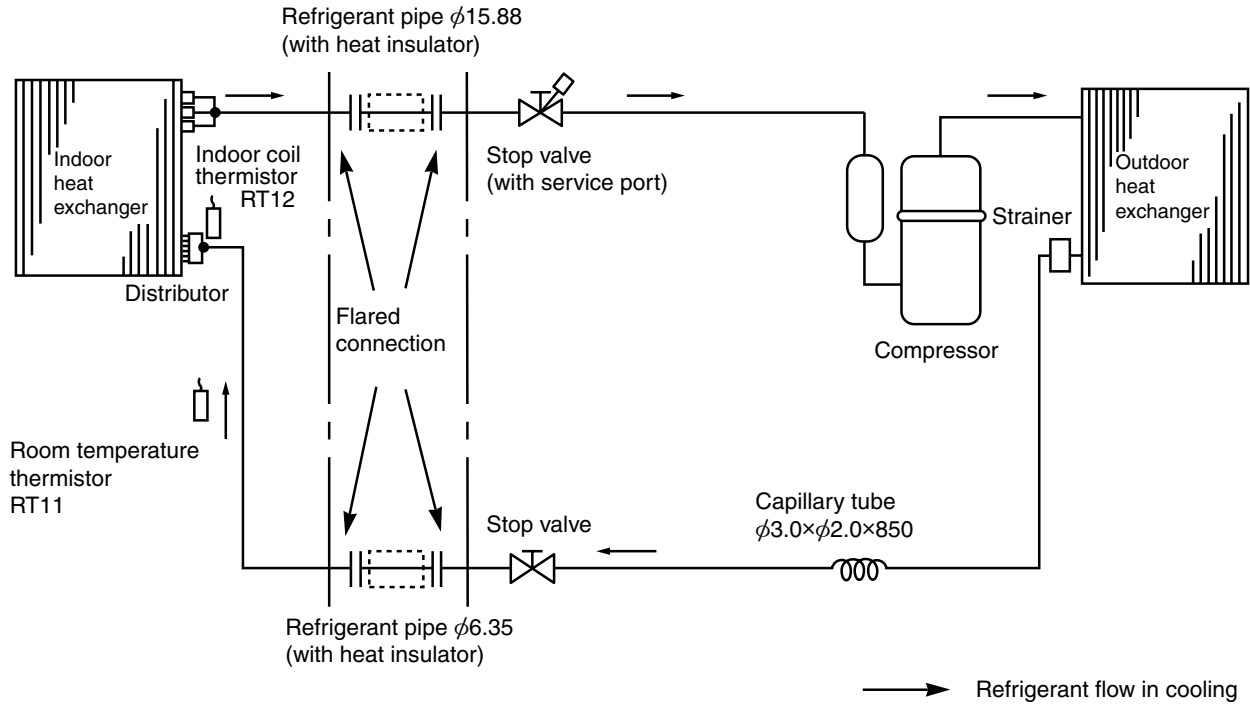

Unit: mm

MS-C24TV

MU-C24TV

INDOOR UNIT

OUTDOOR UNIT

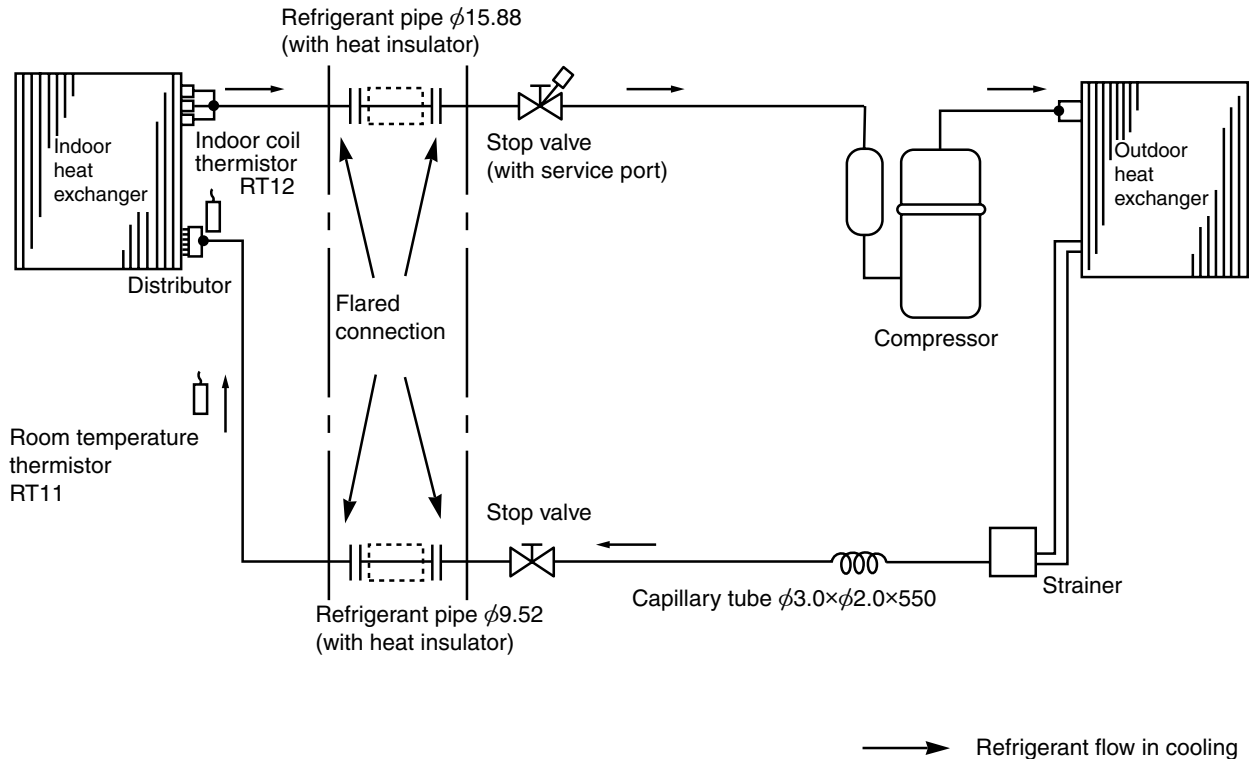

REFRIGERANT SYSTEM DIAGRAM

WALL-MOUNTED

Unit: mm

B.1.4.2 Heat Pump

MSC-C07TV  
MSC-C09TV

MUH-C07TV  
MUH-C09TV

INDOOR UNIT

OUTDOOR UNIT

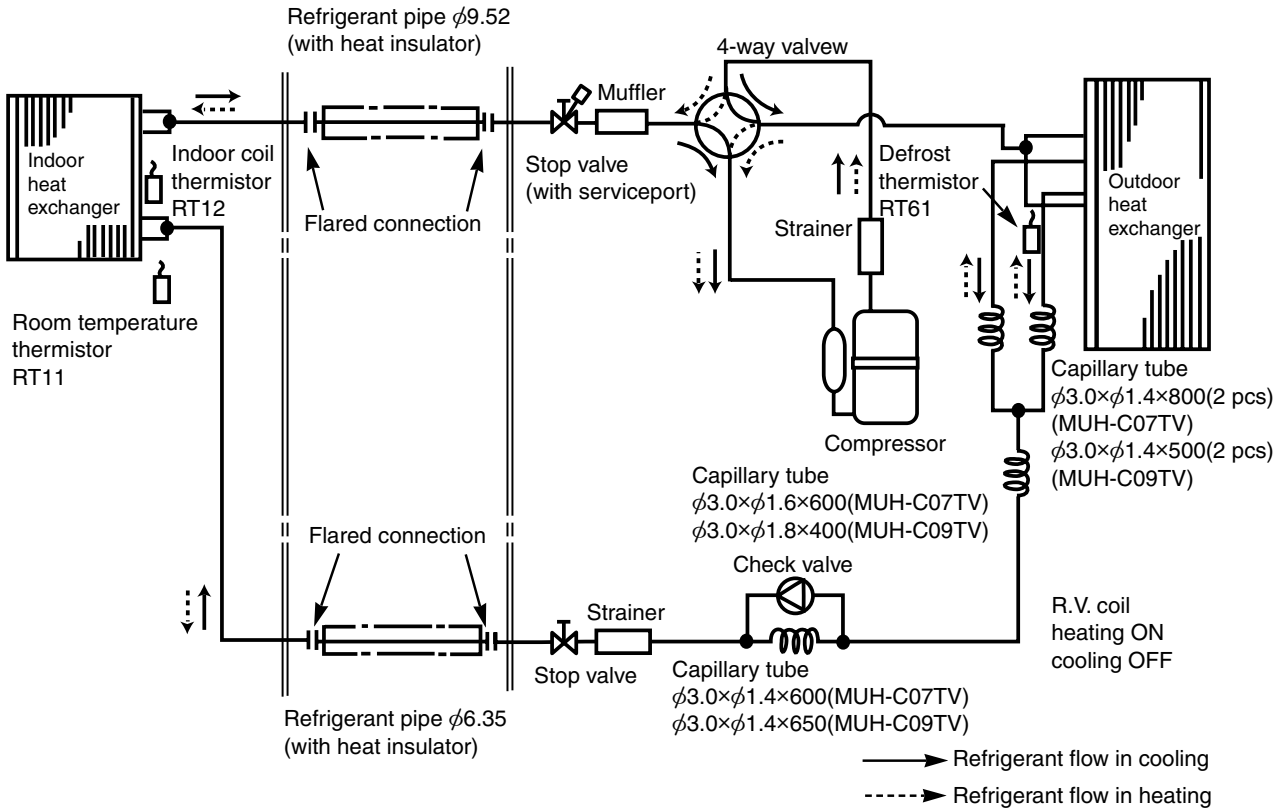

Unit: mm

MSC-C12TV

MUH-C12TV

INDOOR UNIT

OUTDOOR UNIT

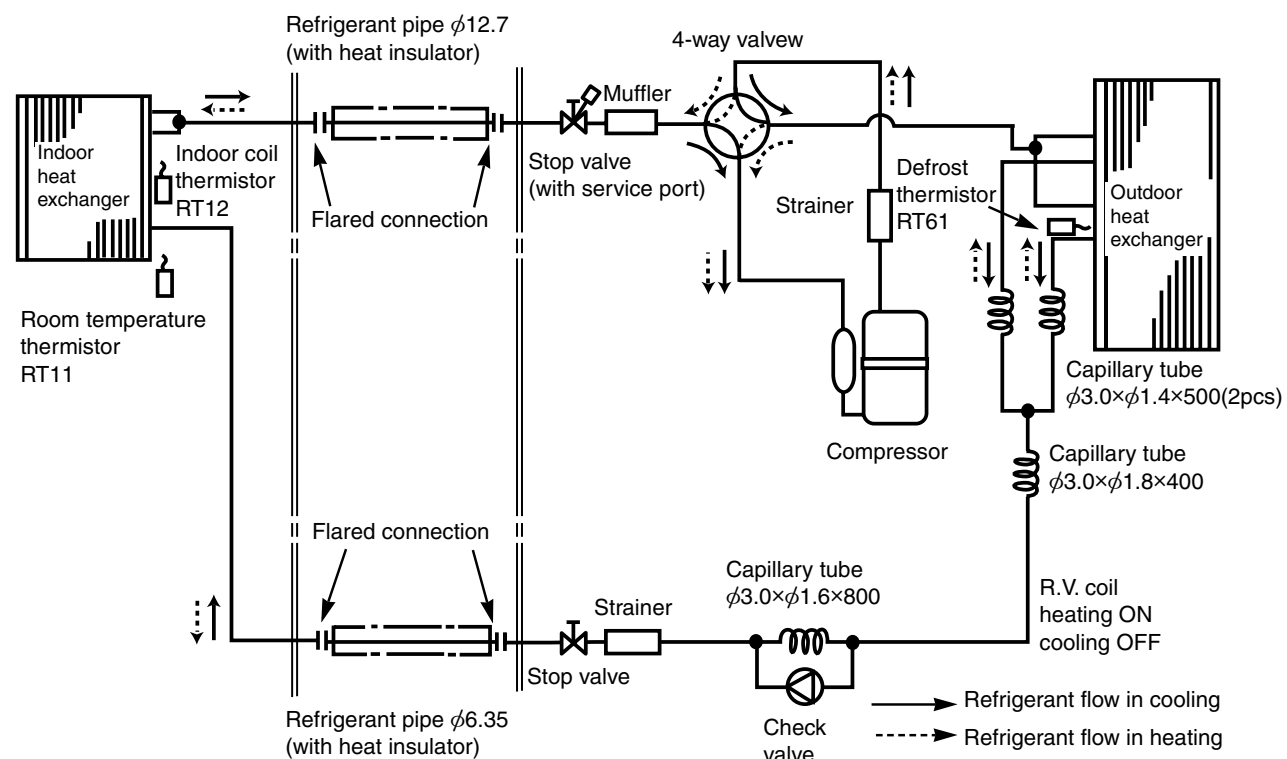

Unit: mm

MSH-C18TV

MUH-C18TV

INDOOR UNIT

OUTDOOR UNIT

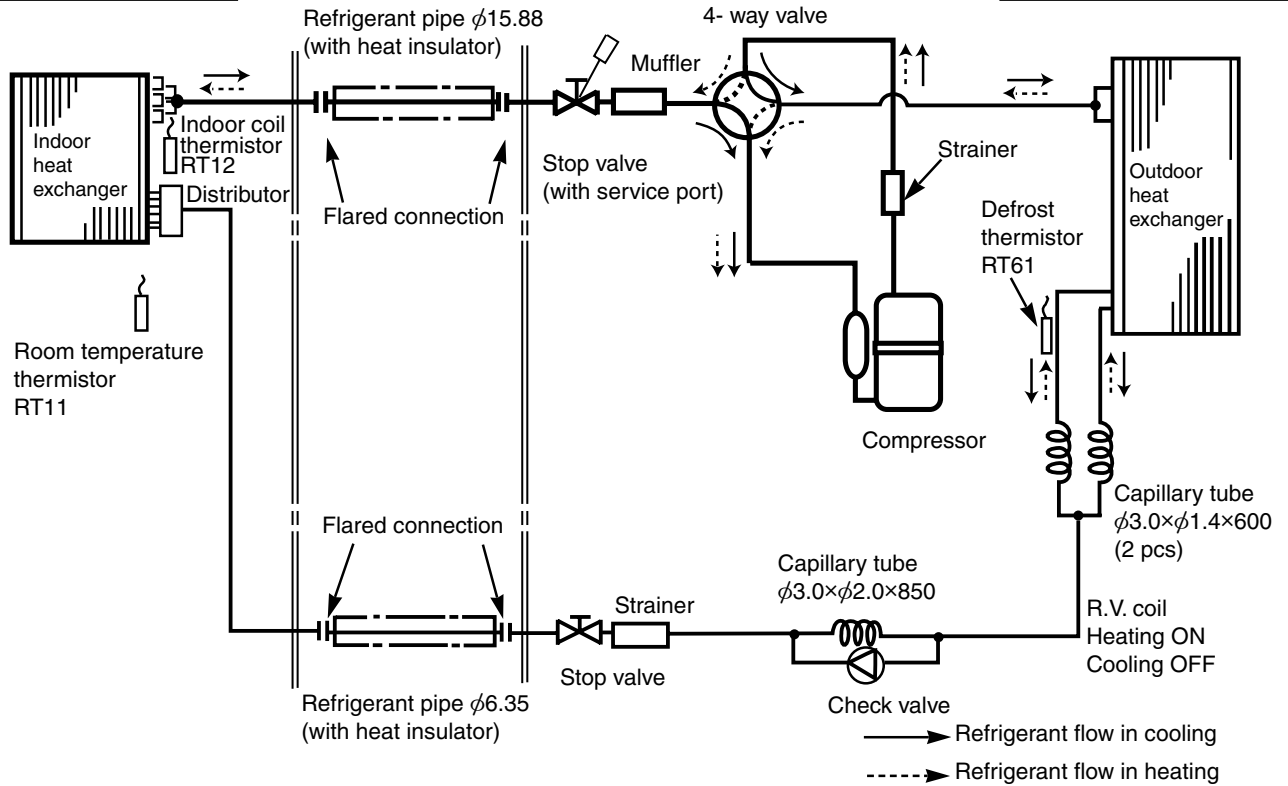

Unit: mm

MSH-C24TV

MUH-C24TV

INDOOR UNIT

OUTDOOR UNIT

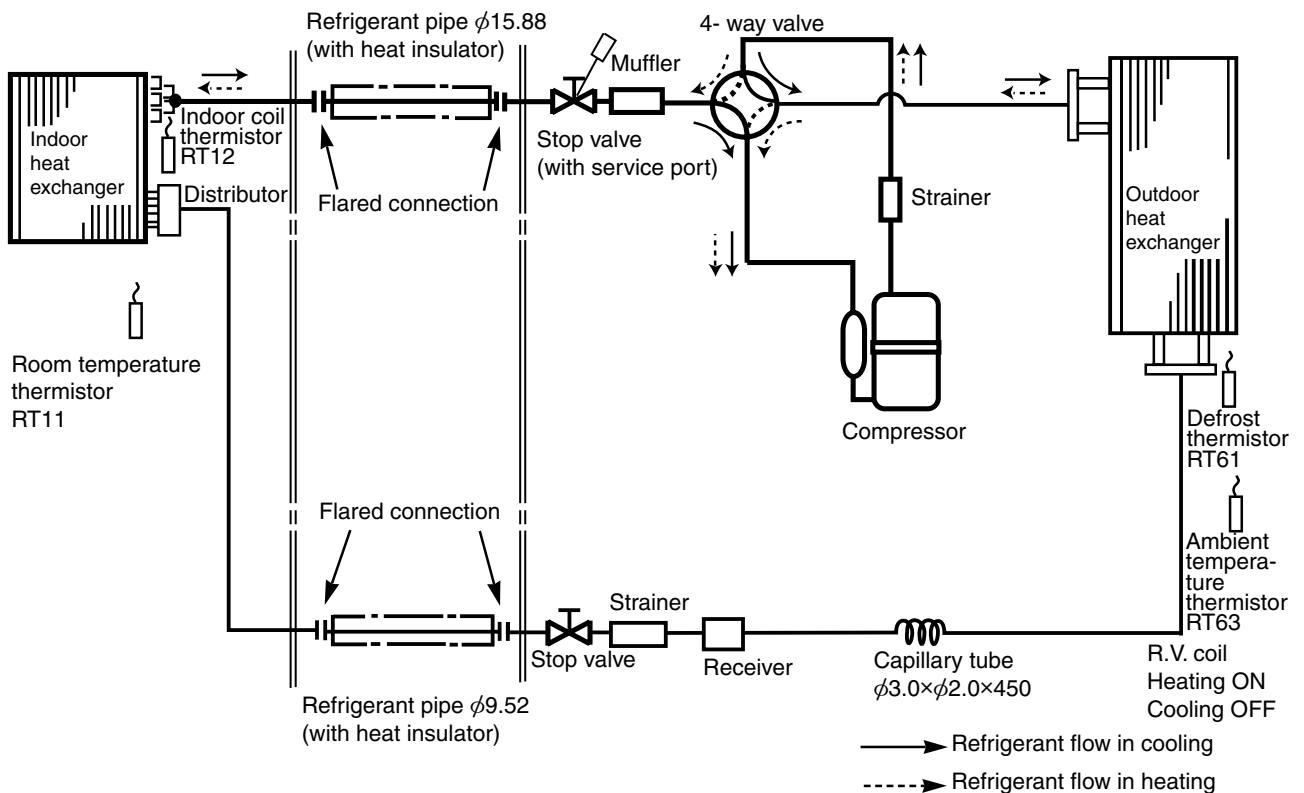

REFRIGERANT SYSTEM DIAGRAM

WALL-MOUNTED

## B.1.5 PERFORMANCE CURVES

The standard data contained in these specifications apply only to the operation of the air conditioner under normal conditions, since operating conditions vary according to the areas where these units are installed. The following information has been provided to clarify the operating characteristics of the air conditioner under the conditions indicated by the performance curve.

**(1) GUARANTEED VOLTAGE**

198 ~ 264V, 50Hz

**(2) AIR FLOW**

Air flow should be set at MAX.

**(3) MAIN READINGS**

- |   |       |   |         |
|---|-------|---|---------|
| (1) Indoor intake air wet-bulb temperature :  | °C WB | } | Cooling |
| (2) Indoor outlet air wet-bulb temperature :  | °C WB |   |         |
| (3) Outdoor intake air dry-bulb temperature : | °C DB | } | Heating |
| (4) Total input:                              | W     |   |         |
| (5) Indoor intake air dry-bulb temperature :  | °C DB | } | Heating |
| (6) Outdoor intake air wet-bulb temperature : | °C WB |   |         |
| (7) Total input :                             | W     |   |         |

Indoor air wet/dry-bulb temperature difference on the left side of the chart on this page and next page shows the difference between the indoor intake air wet/dry-bulb temperature and the indoor outlet air wet/dry-bulb temperature for your reference at service.

**How to measure the indoor air wet-bulb/dry-bulb temperature difference**

1. Attach at least 2 sets of wet-and dry-bulb thermometers to the indoor air intake as shown in the figure, and at least 2 sets of wet-and dry-bulb thermometers to the indoor air outlet. The thermometers must be attached to the position where air speed is high.
2. Attach at least 2 sets of wet-and dry-bulb thermometers to the outdoor air intake.  
Cover the thermometers to prevent direct rays of the sun.
3. Check that the air filter is cleaned.
4. Open windows and doors of room.
5. Press the EMERGENCY OPERATION switch once(twice) to start the EMERGENCY COOL(HEAT) MODE.
6. When system stabilizes after more than 15 minutes, measure temperature and take an average temperature.
7. 10 minutes later, measure temperature again and check that the temperature does not change.

**INDOOR UNIT**

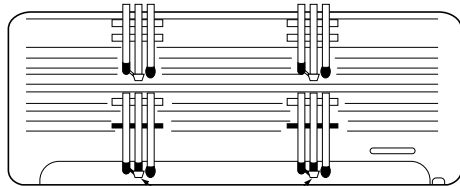

Wet-and dry-bulb thermometers  
FRONT VIEW

**OUTDOOR UNIT**

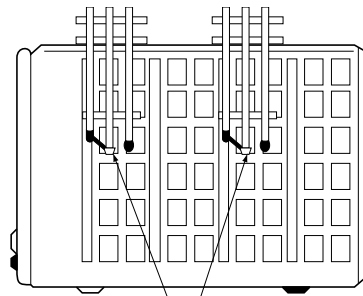

Wet-and dry-bulb thermometers  
BACK VIEW

B.1.5.1 Cool Only/Heat Pump

MSC-C07TV, MU-C07TV  
 MSC-C09TV, MU-C09TV  
 MSC-C12TV, MU-C12TV

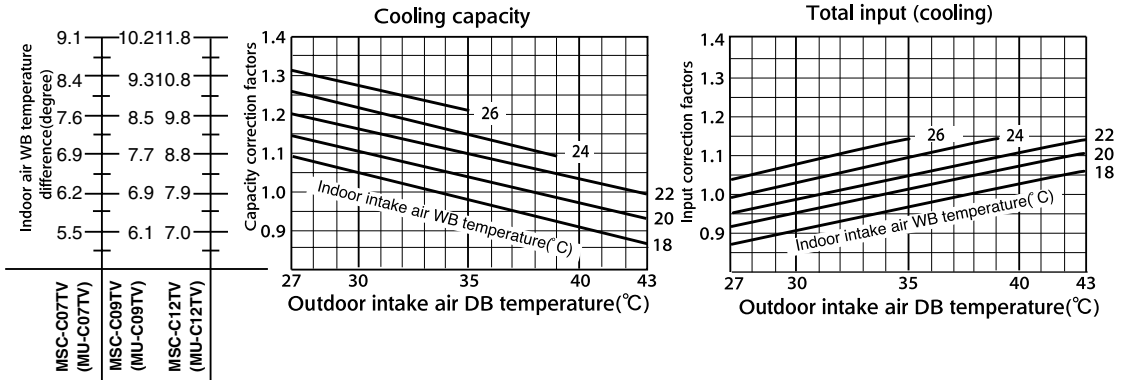

MS-C18TV, MU-C18TV  
 MS-C24TV, MU-C24TV

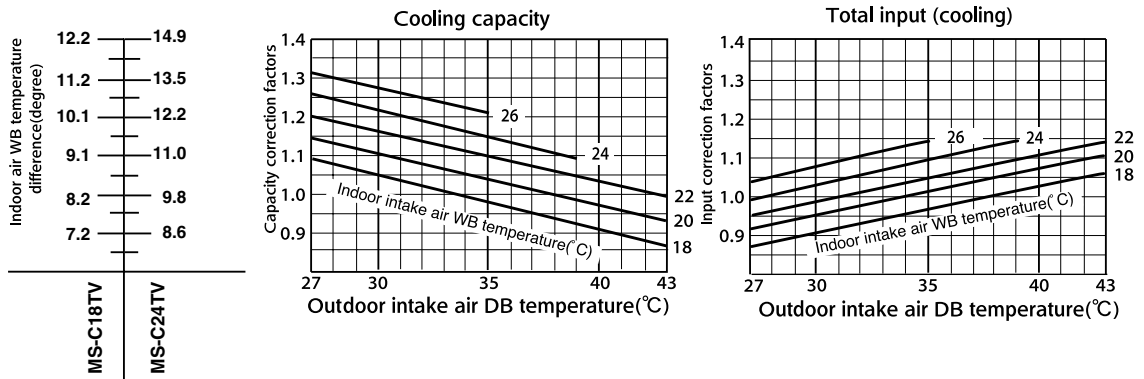

**MSC-C07TV, MUH-C07TV**  
**MSC-C09TV, MUH-C09TV**  
**MSC-C12TV, MUH-C12TV**

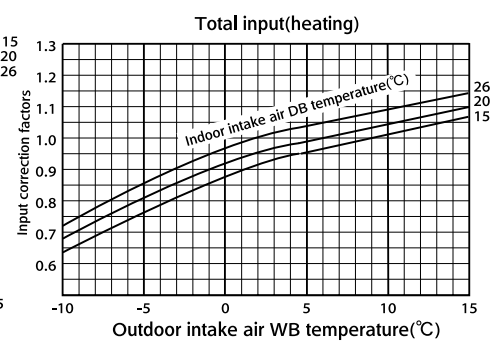
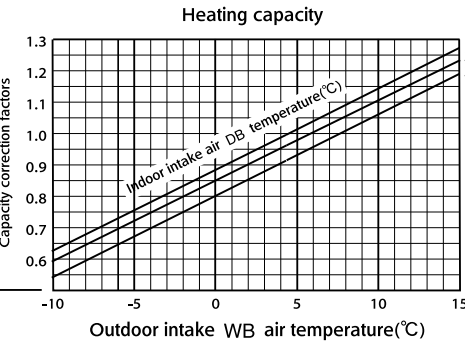
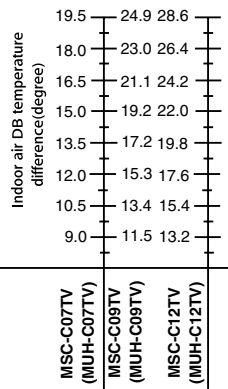
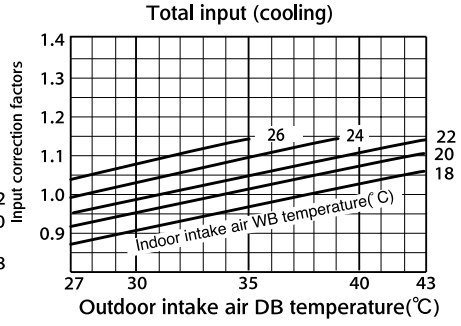
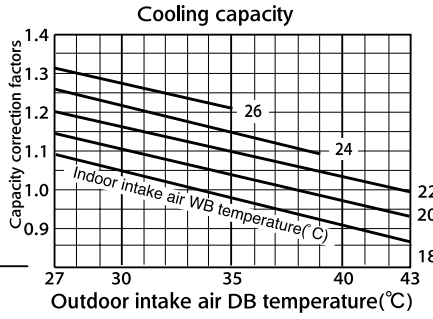
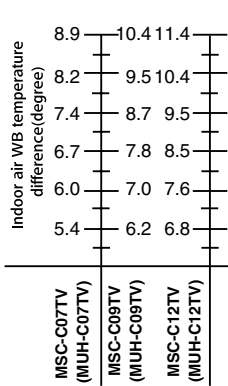

PERFORMANCE CURVES

WALL-MOUNTED



**MSH-C18TV, MUH-C18TV**  
**MSH-C24TV, MUH-C24TV**

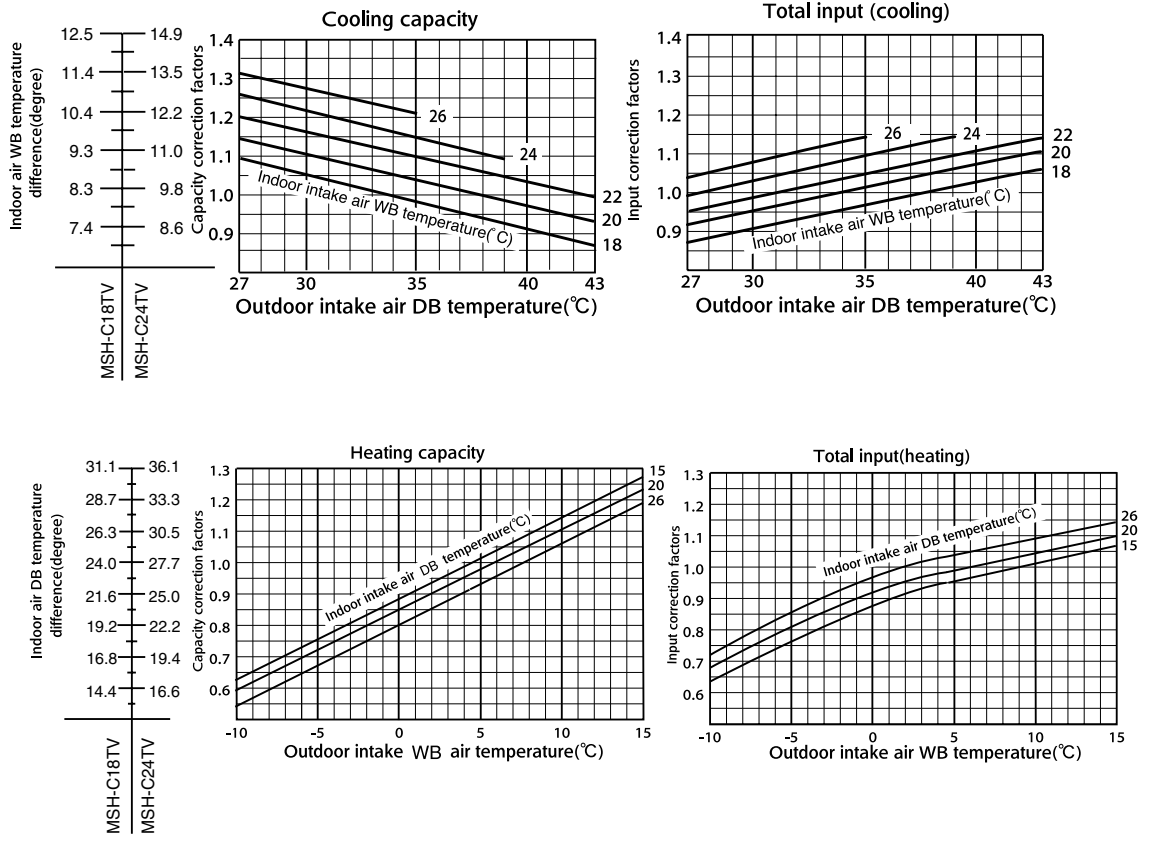

PERFORMANCE CURVES

WALL-MOUNTED

## B.1.6 PERFORMANCE DATA

### B.1.6.1 Cool Only

COOL operation (230V)

MSC-C07TV, MU-C07TV

CAPACITY : 2.25 kW INPUT : 730 W SHF : 0.75

		OUTDOOR DB (°C)															
INDOOR DB (°C)	INDOOR WB (°C)	21				25				27				30			
		Q	SHC	SHF	INPUT	Q	SHC	SHF	INPUT	Q	SHC	SHF	INPUT	Q	SHC	SHF	INPUT
21	18	2.64	1.51	0.57	584	2.53	1.44	0.57	613	2.43	1.39	0.57	642	2.34	1.33	0.57	672
21	20	2.76	1.24	0.45	613	2.64	1.19	0.45	650	2.57	1.15	0.45	664	2.48	1.11	0.45	694
22	18	2.64	1.61	0.61	584	2.53	1.54	0.61	613	2.43	1.48	0.61	642	2.34	1.43	0.61	672
22	20	2.76	1.35	0.49	613	2.64	1.30	0.49	650	2.57	1.26	0.49	664	2.48	1.21	0.49	694
22	22	2.87	1.06	0.37	635	2.77	1.02	0.37	675	2.70	1.00	0.37	694	2.59	0.96	0.37	723
23	18	2.64	1.72	0.65	584	2.53	1.65	0.65	613	2.43	1.58	0.65	642	2.34	1.52	0.65	672
23	20	2.76	1.46	0.53	613	2.64	1.40	0.53	650	2.57	1.36	0.53	664	2.48	1.31	0.53	694
23	22	2.87	1.18	0.41	635	2.77	1.13	0.41	675	2.70	1.11	0.41	694	2.59	1.06	0.41	723
24	18	2.64	1.82	0.69	584	2.53	1.75	0.69	613	2.43	1.68	0.69	642	2.34	1.61	0.69	672
24	20	2.76	1.57	0.57	613	2.64	1.51	0.57	650	2.57	1.46	0.57	664	2.48	1.41	0.57	694
24	22	2.87	1.29	0.45	635	2.77	1.25	0.45	675	2.70	1.22	0.45	694	2.59	1.16	0.45	723
24	24	3.02	0.99	0.33	664	2.90	0.96	0.33	701	2.84	0.94	0.33	723	2.75	0.91	0.33	759
25	18	2.64	1.93	0.73	584	2.53	1.85	0.73	613	2.43	1.77	0.73	642	2.34	1.71	0.73	672
25	20	2.76	1.68	0.61	613	2.64	1.61	0.61	650	2.57	1.56	0.61	664	2.48	1.51	0.61	694
25	22	2.87	1.41	0.49	635	2.77	1.36	0.49	675	2.70	1.32	0.49	694	2.59	1.27	0.49	723
25	24	3.02	1.12	0.37	664	2.90	1.07	0.37	701	2.84	1.05	0.37	723	2.75	1.02	0.37	759
26	18	2.64	2.04	0.77	584	2.53	1.95	0.77	613	2.43	1.87	0.77	642	2.34	1.80	0.77	672
26	20	2.76	1.79	0.65	613	2.64	1.72	0.65	650	2.57	1.67	0.65	664	2.48	1.61	0.65	694
26	22	2.87	1.52	0.53	635	2.77	1.47	0.53	675	2.70	1.43	0.53	694	2.59	1.37	0.53	723
26	24	3.02	1.24	0.41	664	2.90	1.19	0.41	701	2.84	1.16	0.41	723	2.75	1.13	0.41	759
26	26	3.11	0.90	0.29	701	3.02	0.87	0.29	737	2.97	0.86	0.29	759	2.88	0.84	0.29	781
27	18	2.64	2.14	0.81	584	2.53	2.05	0.81	613	2.43	1.97	0.81	642	2.34	1.90	0.81	672
27	20	2.76	1.90	0.69	613	2.64	1.82	0.69	650	2.57	1.77	0.69	664	2.48	1.71	0.69	694
27	22	2.87	1.64	0.57	635	2.77	1.58	0.57	675	2.70	1.54	0.57	694	2.59	1.47	0.57	723
27	24	3.02	1.36	0.45	664	2.90	1.31	0.45	701	2.84	1.28	0.45	723	2.75	1.24	0.45	759
27	26	3.11	1.02	0.33	701	3.02	0.99	0.33	737	2.97	0.98	0.33	759	2.88	0.95	0.33	781
28	18	2.64	2.25	0.85	584	2.53	2.15	0.85	613	2.43	2.07	0.85	642	2.34	1.99	0.85	672
28	20	2.76	2.01	0.73	613	2.64	1.93	0.73	650	2.57	1.87	0.73	664	2.48	1.81	0.73	694
28	22	2.87	1.75	0.61	635	2.77	1.69	0.61	675	2.70	1.65	0.61	694	2.59	1.58	0.61	723
28	24	3.02	1.48	0.49	664	2.90	1.42	0.49	701	2.84	1.39	0.49	723	2.75	1.35	0.49	759
28	26	3.11	1.15	0.37	701	3.02	1.12	0.37	737	2.97	1.10	0.37	759	2.88	1.07	0.37	781
29	18	2.64	2.35	0.89	584	2.53	2.25	0.89	613	2.43	2.16	0.89	642	2.34	2.08	0.89	672
29	20	2.76	2.12	0.77	613	2.64	2.04	0.77	650	2.57	1.98	0.77	664	2.48	1.91	0.77	694
29	22	2.87	1.86	0.65	635	2.77	1.80	0.65	675	2.70	1.76	0.65	694	2.59	1.68	0.65	723
29	24	3.02	1.60	0.53	664	2.90	1.54	0.53	701	2.84	1.50	0.53	723	2.75	1.45	0.53	759
29	26	3.11	1.27	0.41	701	3.02	1.24	0.41	737	2.97	1.22	0.41	759	2.88	1.18	0.41	781
30	18	2.64	2.46	0.93	584	2.53	2.35	0.93	613	2.43	2.26	0.93	642	2.34	2.18	0.93	672
30	20	2.76	2.23	0.81	613	2.64	2.14	0.81	650	2.57	2.08	0.81	664	2.48	2.00	0.81	694
30	22	2.87	1.98	0.69	635	2.77	1.91	0.69	675	2.70	1.86	0.69	694	2.59	1.79	0.69	723
30	24	3.02	1.72	0.57	664	2.90	1.65	0.57	701	2.84	1.62	0.57	723	2.75	1.56	0.57	759
30	26	3.11	1.40	0.45	701	3.02	1.36	0.45	737	2.97	1.34	0.45	759	2.88	1.30	0.45	781
31	18	2.64	2.56	0.97	584	2.53	2.46	0.97	613	2.43	2.36	0.97	642	2.34	2.27	0.97	672
31	20	2.76	2.34	0.85	613	2.64	2.25	0.85	650	2.57	2.18	0.85	664	2.48	2.10	0.85	694
31	22	2.87	2.09	0.73	635	2.77	2.02	0.73	675	2.70	1.97	0.73	694	2.59	1.89	0.73	723
31	24	3.02	1.84	0.61	664	2.90	1.77	0.61	701	2.84	1.73	0.61	723	2.75	1.67	0.61	759
31	26	3.11	1.52	0.49	701	3.02	1.48	0.49	737	2.97	1.46	0.49	759	2.88	1.41	0.49	781
32	18	2.64	2.67	1.01	584	2.53	2.56	1.01	613	2.43	2.45	1.01	642	2.34	2.36	1.01	672
32	20	2.76	2.45	0.89	613	2.64	2.35	0.89	650	2.57	2.28	0.89	664	2.48	2.20	0.89	694
32	22	2.87	2.21	0.77	635	2.77	2.13	0.77	675	2.70	2.08	0.77	694	2.59	1.99	0.77	723
32	24	3.02	1.96	0.65	664	2.90	1.89	0.65	701	2.84	1.84	0.65	723	2.75	1.78	0.65	759
32	26	3.11	1.65	0.53	701	3.02	1.60	0.53	737	2.97	1.57	0.53	759	2.88	1.53	0.53	781

**NOTE:** Q: Total capacity (kW) SHF: Sensible heat factor DB: Dry-bulb temperature  
 SHC: Sensible heat capacity (kW) INPUT: Total power input (W) WB: Wet-bulb temperature

**COOL operation (230V)  
MSC-C07TV, MU-C07TV**

CAPACITY : 2.25 kW INPUT : 730 W SHF : 0.75

		OUTDOOR DB (°C)															
INDOOR DB (°C)	INDOOR WB (°C)	35				40				43				46			
		Q	SHC	SHF	INPUT	Q	SHC	SHF	INPUT	Q	SHC	SHF	INPUT	Q	SHC	SHF	INPUT
21	18	2.21	1.26	0.57	715	2.03	1.15	0.57	759	1.95	1.11	0.57	774	1.87	1.06	0.57	788
21	20	2.32	1.04	0.45	745	2.16	0.97	0.45	781	2.08	0.94	0.45	803	2.00	0.90	0.45	825
22	18	2.21	1.35	0.61	715	2.03	1.24	0.61	759	1.95	1.19	0.61	774	1.87	1.14	0.61	788
22	20	2.32	1.14	0.49	745	2.16	1.06	0.49	781	2.08	1.02	0.49	803	2.00	0.98	0.49	825
22	22	2.45	0.91	0.37	774	2.30	0.85	0.37	818	2.22	0.82	0.37	832	2.14	0.79	0.37	847
23	18	2.21	1.43	0.65	715	2.03	1.32	0.65	759	1.95	1.27	0.65	774	1.87	1.21	0.65	788
23	20	2.32	1.23	0.53	745	2.16	1.14	0.53	781	2.08	1.10	0.53	803	2.00	1.06	0.53	825
23	22	2.45	1.01	0.41	774	2.30	0.94	0.41	818	2.22	0.91	0.41	832	2.14	0.88	0.41	847
24	18	2.21	1.52	0.69	715	2.03	1.40	0.69	759	1.95	1.34	0.69	774	1.87	1.29	0.69	788
24	20	2.32	1.32	0.57	745	2.16	1.23	0.57	781	2.08	1.19	0.57	803	2.00	1.14	0.57	825
24	22	2.45	1.10	0.45	774	2.30	1.03	0.45	818	2.22	1.00	0.45	832	2.14	0.96	0.45	847
24	24	2.59	0.85	0.33	803	2.43	0.80	0.33	840	2.36	0.78	0.33	858	2.30	0.76	0.33	876
25	18	2.21	1.61	0.73	715	2.03	1.48	0.73	759	1.95	1.42	0.73	774	1.87	1.36	0.73	788
25	20	2.32	1.41	0.61	745	2.16	1.32	0.61	781	2.08	1.27	0.61	803	2.00	1.22	0.61	825
25	22	2.45	1.20	0.49	774	2.30	1.12	0.49	818	2.22	1.09	0.49	832	2.14	1.05	0.49	847
25	24	2.59	0.96	0.37	803	2.43	0.90	0.37	840	2.36	0.87	0.37	858	2.30	0.85	0.37	876
26	18	2.21	1.70	0.77	715	2.03	1.56	0.77	759	1.95	1.50	0.77	774	1.87	1.44	0.77	788
26	20	2.32	1.51	0.65	745	2.16	1.40	0.65	781	2.08	1.35	0.65	803	2.00	1.30	0.65	825
26	22	2.45	1.30	0.53	774	2.30	1.22	0.53	818	2.22	1.17	0.53	832	2.14	1.13	0.53	847
26	24	2.59	1.06	0.41	803	2.43	1.00	0.41	840	2.36	0.97	0.41	858	2.30	0.94	0.41	876
26	26	2.72	0.79	0.29	832	2.57	0.74	0.29	869	2.49	0.72	0.29	887	2.41	0.70	0.29	905
27	18	2.21	1.79	0.81	715	2.03	1.64	0.81	759	1.95	1.58	0.81	774	1.87	1.51	0.81	788
27	20	2.32	1.60	0.69	745	2.16	1.49	0.69	781	2.08	1.44	0.69	803	2.00	1.38	0.69	825
27	22	2.45	1.40	0.57	774	2.30	1.31	0.57	818	2.22	1.26	0.57	832	2.14	1.22	0.57	847
27	24	2.59	1.16	0.45	803	2.43	1.09	0.45	840	2.36	1.06	0.45	858	2.30	1.03	0.45	876
27	26	2.72	0.90	0.33	832	2.57	0.85	0.33	869	2.49	0.82	0.33	887	2.41	0.79	0.33	905
28	18	2.21	1.87	0.85	715	2.03	1.72	0.85	759	1.95	1.65	0.85	774	1.87	1.59	0.85	788
28	20	2.32	1.69	0.73	745	2.16	1.58	0.73	781	2.08	1.52	0.73	803	2.00	1.46	0.73	825
28	22	2.45	1.50	0.61	774	2.30	1.40	0.61	818	2.22	1.35	0.61	832	2.14	1.30	0.61	847
28	24	2.59	1.27	0.49	803	2.43	1.19	0.49	840	2.36	1.16	0.49	858	2.30	1.12	0.49	876
28	26	2.72	1.01	0.37	832	2.57	0.95	0.37	869	2.49	0.92	0.37	887	2.41	0.89	0.37	905
29	18	2.21	1.96	0.89	715	2.03	1.80	0.89	759	1.95	1.73	0.89	774	1.87	1.66	0.89	788
29	20	2.32	1.78	0.77	745	2.16	1.66	0.77	781	2.08	1.60	0.77	803	2.00	1.54	0.77	825
29	22	2.45	1.59	0.65	774	2.30	1.49	0.65	818	2.22	1.44	0.65	832	2.14	1.39	0.65	847
29	24	2.59	1.37	0.53	803	2.43	1.29	0.53	840	2.36	1.25	0.53	858	2.30	1.22	0.53	876
29	26	2.72	1.12	0.41	832	2.57	1.05	0.41	869	2.49	1.02	0.41	887	2.41	0.99	0.41	905
30	18	2.21	2.05	0.93	715	2.03	1.88	0.93	759	1.95	1.81	0.93	774	1.87	1.74	0.93	788
30	20	2.32	1.88	0.81	745	2.16	1.75	0.81	781	2.08	1.69	0.81	803	2.00	1.62	0.81	825
30	22	2.45	1.69	0.69	774	2.30	1.58	0.69	818	2.22	1.53	0.69	832	2.14	1.47	0.69	847
30	24	2.59	1.47	0.57	803	2.43	1.39	0.57	840	2.36	1.35	0.57	858	2.30	1.31	0.57	876
30	26	2.72	1.23	0.45	832	2.57	1.15	0.45	869	2.49	1.12	0.45	887	2.41	1.08	0.45	905
31	18	2.21	2.14	0.97	715	2.03	1.96	0.97	759	1.95	1.89	0.97	774	1.87	1.81	0.97	788
31	20	2.32	1.97	0.85	745	2.16	1.84	0.85	781	2.08	1.77	0.85	803	2.00	1.70	0.85	825
31	22	2.45	1.79	0.73	774	2.30	1.68	0.73	818	2.22	1.62	0.73	832	2.14	1.56	0.73	847
31	24	2.59	1.58	0.61	803	2.43	1.48	0.61	840	2.36	1.44	0.61	858	2.30	1.40	0.61	876
31	26	2.72	1.33	0.49	832	2.57	1.26	0.49	869	2.49	1.22	0.49	887	2.41	1.18	0.49	905
32	18	2.21	2.23	1.01	715	2.03	2.05	1.01	759	1.95	1.97	1.01	774	1.87	1.89	1.01	788
32	20	2.32	2.06	0.89	745	2.16	1.92	0.89	781	2.08	1.85	0.89	803	2.00	1.78	0.89	825
32	22	2.45	1.89	0.77	774	2.30	1.77	0.77	818	2.22	1.71	0.77	832	2.14	1.65	0.77	847
32	24	2.59	1.68	0.65	803	2.43	1.58	0.65	840	2.36	1.54	0.65	858	2.30	1.49	0.65	876
32	26	2.72	1.44	0.53	832	2.57	1.36	0.53	869	2.49	1.32	0.53	887	2.41	1.28	0.53	905

**NOTE:** Q: Total capacity (kW) SHF: Sensible heat factor DB: Dry-bulb temperature  
SHC: Sensible heat capacity (kW) INPUT: Total power input (W) WB: Wet-bulb temperature

PERFORMANCE DATA

WALL-MOUNTED

**COOL operation (230V)**  
**MSC-C09TV, MU-C09TV**

CAPACITY : 2.50 kW INPUT : 830 W SHF : 0.73

		OUTDOOR DB (°C)															
INDOOR DB (°C)	INDOOR WB (°C)	21				25				27				30			
		Q	SHC	SHF	INPUT	Q	SHC	SHF	INPUT	Q	SHC	SHF	INPUT	Q	SHC	SHF	INPUT
21	18	2.94	1.62	0.55	664	2.81	1.55	0.55	697	2.70	1.49	0.55	730	2.60	1.43	0.55	764
21	20	3.06	1.32	0.43	697	2.94	1.26	0.43	739	2.85	1.23	0.43	755	2.75	1.18	0.43	789
22	18	2.94	1.73	0.59	664	2.81	1.66	0.59	697	2.70	1.59	0.59	730	2.60	1.53	0.59	764
22	20	3.06	1.44	0.47	697	2.94	1.38	0.47	739	2.85	1.34	0.47	755	2.75	1.29	0.47	789
22	22	3.19	1.12	0.35	722	3.08	1.08	0.35	768	3.00	1.05	0.35	789	2.88	1.01	0.35	822
23	18	2.94	1.85	0.63	664	2.81	1.77	0.63	697	2.70	1.70	0.63	730	2.60	1.64	0.63	764
23	20	3.06	1.56	0.51	697	2.94	1.50	0.51	739	2.85	1.45	0.51	755	2.75	1.40	0.51	789
23	22	3.19	1.24	0.39	722	3.08	1.20	0.39	768	3.00	1.17	0.39	789	2.88	1.12	0.39	822
24	18	2.94	1.97	0.67	664	2.81	1.88	0.67	697	2.70	1.81	0.67	730	2.60	1.74	0.67	764
24	20	3.06	1.68	0.55	697	2.94	1.62	0.55	739	2.85	1.57	0.55	755	2.75	1.51	0.55	789
24	22	3.19	1.37	0.43	722	3.08	1.32	0.43	768	3.00	1.29	0.43	789	2.88	1.24	0.43	822
24	24	3.35	1.04	0.31	755	3.23	1.00	0.31	797	3.15	0.98	0.31	822	3.05	0.95	0.31	863
25	18	2.94	2.09	0.71	664	2.81	2.00	0.71	697	2.70	1.92	0.71	730	2.60	1.85	0.71	764
25	20	3.06	1.81	0.59	697	2.94	1.73	0.59	739	2.85	1.68	0.59	755	2.75	1.62	0.59	789
25	22	3.19	1.50	0.47	722	3.08	1.45	0.47	768	3.00	1.41	0.47	789	2.88	1.35	0.47	822
25	24	3.35	1.17	0.35	755	3.23	1.13	0.35	797	3.15	1.10	0.35	822	3.05	1.07	0.35	863
26	18	2.94	2.20	0.75	664	2.81	2.11	0.75	697	2.70	2.03	0.75	730	2.60	1.95	0.75	764
26	20	3.06	1.93	0.63	697	2.94	1.85	0.63	739	2.85	1.80	0.63	755	2.75	1.73	0.63	789
26	22	3.19	1.63	0.51	722	3.08	1.57	0.51	768	3.00	1.53	0.51	789	2.88	1.47	0.51	822
26	24	3.35	1.31	0.39	755	3.23	1.26	0.39	797	3.15	1.23	0.39	822	3.05	1.19	0.39	863
26	26	3.45	0.93	0.27	797	3.35	0.90	0.27	838	3.30	0.89	0.27	863	3.20	0.86	0.27	888
27	18	2.94	2.32	0.79	664	2.81	2.22	0.79	697	2.70	2.13	0.79	730	2.60	2.05	0.79	764
27	20	3.06	2.05	0.67	697	2.94	1.97	0.67	739	2.85	1.91	0.67	755	2.75	1.84	0.67	789
27	22	3.19	1.75	0.55	722	3.08	1.69	0.55	768	3.00	1.65	0.55	789	2.88	1.58	0.55	822
27	24	3.35	1.44	0.43	755	3.23	1.39	0.43	797	3.15	1.35	0.43	822	3.05	1.31	0.43	863
27	26	3.45	1.07	0.31	797	3.35	1.04	0.31	838	3.30	1.02	0.31	863	3.20	0.99	0.31	888
28	18	2.94	2.44	0.83	664	2.81	2.33	0.83	697	2.70	2.24	0.83	730	2.60	2.16	0.83	764
28	20	3.06	2.17	0.71	697	2.94	2.09	0.71	739	2.85	2.02	0.71	755	2.75	1.95	0.71	789
28	22	3.19	1.88	0.59	722	3.08	1.81	0.59	768	3.00	1.77	0.59	789	2.88	1.70	0.59	822
28	24	3.35	1.57	0.47	755	3.23	1.52	0.47	797	3.15	1.48	0.47	822	3.05	1.43	0.47	863
28	26	3.45	1.21	0.35	797	3.35	1.17	0.35	838	3.30	1.16	0.35	863	3.20	1.12	0.35	888
29	18	2.94	2.56	0.87	664	2.81	2.45	0.87	697	2.70	2.35	0.87	730	2.60	2.26	0.87	764
29	20	3.06	2.30	0.75	697	2.94	2.20	0.75	739	2.85	2.14	0.75	755	2.75	2.06	0.75	789
29	22	3.19	2.01	0.63	722	3.08	1.94	0.63	768	3.00	1.89	0.63	789	2.88	1.81	0.63	822
29	24	3.35	1.71	0.51	755	3.23	1.64	0.51	797	3.15	1.61	0.51	822	3.05	1.56	0.51	863
29	26	3.45	1.35	0.39	797	3.35	1.31	0.39	838	3.30	1.29	0.39	863	3.20	1.25	0.39	888
30	18	2.94	2.67	0.91	664	2.81	2.56	0.91	697	2.70	2.46	0.91	730	2.60	2.37	0.91	764
30	20	3.06	2.42	0.79	697	2.94	2.32	0.79	739	2.85	2.25	0.79	755	2.75	2.17	0.79	789
30	22	3.19	2.14	0.67	722	3.08	2.06	0.67	768	3.00	2.01	0.67	789	2.88	1.93	0.67	822
30	24	3.35	1.84	0.55	755	3.23	1.77	0.55	797	3.15	1.73	0.55	822	3.05	1.68	0.55	863
30	26	3.45	1.48	0.43	797	3.35	1.44	0.43	838	3.30	1.42	0.43	863	3.20	1.38	0.43	888
31	18	2.94	2.79	0.95	664	2.81	2.67	0.95	697	2.70	2.57	0.95	730	2.60	2.47	0.95	764
31	20	3.06	2.54	0.83	697	2.94	2.44	0.83	739	2.85	2.37	0.83	755	2.75	2.28	0.83	789
31	22	3.19	2.26	0.71	722	3.08	2.18	0.71	768	3.00	2.13	0.71	789	2.88	2.04	0.71	822
31	24	3.35	1.98	0.59	755	3.23	1.90	0.59	797	3.15	1.86	0.59	822	3.05	1.80	0.59	863
31	26	3.45	1.62	0.47	797	3.35	1.57	0.47	838	3.30	1.55	0.47	863	3.20	1.50	0.47	888
32	18	2.94	2.91	0.99	664	2.81	2.78	0.99	697	2.70	2.67	0.99	730	2.60	2.57	0.99	764
32	20	3.06	2.66	0.87	697	2.94	2.56	0.87	739	2.85	2.48	0.87	755	2.75	2.39	0.87	789
32	22	3.19	2.39	0.75	722	3.08	2.31	0.75	768	3.00	2.25	0.75	789	2.88	2.16	0.75	822
32	24	3.35	2.11	0.63	755	3.23	2.03	0.63	797	3.15	1.98	0.63	822	3.05	1.92	0.63	863
32	26	3.45	1.76	0.51	797	3.35	1.71	0.51	838	3.30	1.68	0.51	863	3.20	1.63	0.51	888

**NOTE:** Q: Total capacity (kW) SHF: Sensible heat factor DB: Dry-bulb temperature  
SHC: Sensible heat capacity (kW) INPUT: Total power input (W) WB: Wet-bulb temperature

**COOL operation (230V)  
MSC-C09TV, MU-C09TV**

CAPACITY : 2.50 kW INPUT : 830 W SHF : 0.73

INDOOR		OUTDOOR DB (°C)															
DB (°C)	WB (°C)	35				40				43				46			
		Q	SHC	SHF	INPUT	Q	SHC	SHF	INPUT	Q	SHC	SHF	INPUT	Q	SHC	SHF	INPUT
21	18	2.45	1.35	0.55	813	2.25	1.24	0.55	863	2.16	1.19	0.55	880	2.08	1.14	0.55	896
21	20	2.58	1.11	0.43	847	2.40	1.03	0.43	888	2.31	0.99	0.43	913	2.23	0.96	0.43	938
22	18	2.45	1.45	0.59	813	2.25	1.33	0.59	863	2.16	1.28	0.59	880	2.08	1.22	0.59	896
22	20	2.58	1.21	0.47	847	2.40	1.13	0.47	888	2.31	1.09	0.47	913	2.23	1.05	0.47	938
22	22	2.73	0.95	0.35	880	2.55	0.89	0.35	930	2.46	0.86	0.35	946	2.38	0.83	0.35	963
23	18	2.45	1.54	0.63	813	2.25	1.42	0.63	863	2.16	1.36	0.63	880	2.08	1.31	0.63	896
23	20	2.58	1.31	0.51	847	2.40	1.22	0.51	888	2.31	1.18	0.51	913	2.23	1.13	0.51	938
23	22	2.73	1.06	0.39	880	2.55	0.99	0.39	930	2.46	0.96	0.39	946	2.38	0.93	0.39	963
24	18	2.45	1.64	0.67	813	2.25	1.51	0.67	863	2.16	1.45	0.67	880	2.08	1.39	0.67	896
24	20	2.58	1.42	0.55	847	2.40	1.32	0.55	888	2.31	1.27	0.55	913	2.23	1.22	0.55	938
24	22	2.73	1.17	0.43	880	2.55	1.10	0.43	930	2.46	1.06	0.43	946	2.38	1.02	0.43	963
24	24	2.88	0.89	0.31	913	2.70	0.84	0.31	955	2.63	0.81	0.31	975	2.55	0.79	0.31	996
25	18	2.45	1.74	0.71	813	2.25	1.60	0.71	863	2.16	1.54	0.71	880	2.08	1.47	0.71	896
25	20	2.58	1.52	0.59	847	2.40	1.42	0.59	888	2.31	1.36	0.59	913	2.23	1.31	0.59	938
25	22	2.73	1.28	0.47	880	2.55	1.20	0.47	930	2.46	1.16	0.47	946	2.38	1.12	0.47	963
25	24	2.88	1.01	0.35	913	2.70	0.95	0.35	955	2.63	0.92	0.35	975	2.55	0.89	0.35	996
26	18	2.45	1.84	0.75	813	2.25	1.69	0.75	863	2.16	1.62	0.75	880	2.08	1.56	0.75	896
26	20	2.58	1.62	0.63	847	2.40	1.51	0.63	888	2.31	1.46	0.63	913	2.23	1.40	0.63	938
26	22	2.73	1.39	0.51	880	2.55	1.30	0.51	930	2.46	1.26	0.51	946	2.38	1.21	0.51	963
26	24	2.88	1.12	0.39	913	2.70	1.05	0.39	955	2.63	1.02	0.39	975	2.55	0.99	0.39	996
26	26	3.03	0.82	0.27	946	2.85	0.77	0.27	988	2.76	0.75	0.27	1008	2.68	0.72	0.27	1029
27	18	2.45	1.94	0.79	813	2.25	1.78	0.79	863	2.16	1.71	0.79	880	2.08	1.64	0.79	896
27	20	2.58	1.73	0.67	847	2.40	1.61	0.67	888	2.31	1.55	0.67	913	2.23	1.49	0.67	938
27	22	2.73	1.50	0.55	880	2.55	1.40	0.55	930	2.46	1.35	0.55	946	2.38	1.31	0.55	963
27	24	2.88	1.24	0.43	913	2.70	1.16	0.43	955	2.63	1.13	0.43	975	2.55	1.10	0.43	996
27	26	3.03	0.94	0.31	946	2.85	0.88	0.31	988	2.76	0.86	0.31	1008	2.68	0.83	0.31	1029
28	18	2.45	2.03	0.83	813	2.25	1.87	0.83	863	2.16	1.79	0.83	880	2.08	1.72	0.83	896
28	20	2.58	1.83	0.71	847	2.40	1.70	0.71	888	2.31	1.64	0.71	913	2.23	1.58	0.71	938
28	22	2.73	1.61	0.59	880	2.55	1.50	0.59	930	2.46	1.45	0.59	946	2.38	1.40	0.59	963
28	24	2.88	1.35	0.47	913	2.70	1.27	0.47	955	2.63	1.23	0.47	975	2.55	1.20	0.47	996
28	26	3.03	1.06	0.35	946	2.85	1.00	0.35	988	2.76	0.97	0.35	1008	2.68	0.94	0.35	1029
29	18	2.45	2.13	0.87	813	2.25	1.96	0.87	863	2.16	1.88	0.87	880	2.08	1.81	0.87	896
29	20	2.58	1.93	0.75	847	2.40	1.80	0.75	888	2.31	1.73	0.75	913	2.23	1.67	0.75	938
29	22	2.73	1.72	0.63	880	2.55	1.61	0.63	930	2.46	1.55	0.63	946	2.38	1.50	0.63	963
29	24	2.88	1.47	0.51	913	2.70	1.38	0.51	955	2.63	1.34	0.51	975	2.55	1.30	0.51	996
29	26	3.03	1.18	0.39	946	2.85	1.11	0.39	988	2.76	1.08	0.39	1008	2.68	1.04	0.39	1029
30	18	2.45	2.23	0.91	813	2.25	2.05	0.91	863	2.16	1.97	0.91	880	2.08	1.89	0.91	896
30	20	2.58	2.03	0.79	847	2.40	1.90	0.79	888	2.31	1.83	0.79	913	2.23	1.76	0.79	938
30	22	2.73	1.83	0.67	880	2.55	1.71	0.67	930	2.46	1.65	0.67	946	2.38	1.59	0.67	963
30	24	2.88	1.58	0.55	913	2.70	1.49	0.55	955	2.63	1.44	0.55	975	2.55	1.40	0.55	996
30	26	3.03	1.30	0.43	946	2.85	1.23	0.43	988	2.76	1.19	0.43	1008	2.68	1.15	0.43	1029
31	18	2.45	2.33	0.95	813	2.25	2.14	0.95	863	2.16	2.05	0.95	880	2.08	1.97	0.95	896
31	20	2.58	2.14	0.83	847	2.40	1.99	0.83	888	2.31	1.92	0.83	913	2.23	1.85	0.83	938
31	22	2.73	1.93	0.71	880	2.55	1.81	0.71	930	2.46	1.75	0.71	946	2.38	1.69	0.71	963
31	24	2.88	1.70	0.59	913	2.70	1.59	0.59	955	2.63	1.55	0.59	975	2.55	1.50	0.59	996
31	26	3.03	1.42	0.47	946	2.85	1.34	0.47	988	2.76	1.30	0.47	1008	2.68	1.26	0.47	1029
32	18	2.45	2.43	0.99	813	2.25	2.23	0.99	863	2.16	2.14	0.99	880	2.08	2.05	0.99	896
32	20	2.58	2.24	0.87	847	2.40	2.09	0.87	888	2.31	2.01	0.87	913	2.23	1.94	0.87	938
32	22	2.73	2.04	0.75	880	2.55	1.91	0.75	930	2.46	1.85	0.75	946	2.38	1.78	0.75	963
32	24	2.88	1.81	0.63	913	2.70	1.70	0.63	955	2.63	1.65	0.63	975	2.55	1.61	0.63	996
32	26	3.03	1.54	0.51	946	2.85	1.45	0.51	988	2.76	1.41	0.51	1008	2.68	1.36	0.51	1029

**NOTE:** Q: Total capacity (kW) SHF: Sensible heat factor DB: Dry-bulb temperature  
SHC: Sensible heat capacity (kW) INPUT: Total power input (W) WB: Wet-bulb temperature

PERFORMANCE DATA

WALL-MOUNTED

**COOL operation (230V)**  
**MSC-C12TV, MU-C12TV**

CAPACITY : 3.55 kW INPUT : 1370 W SHF : 0.69

		OUTDOOR DB (°C)															
INDOOR DB (°C)	INDOOR WB (°C)	21				25				27				30			
		Q	SHC	SHF	INPUT	Q	SHC	SHF	INPUT	Q	SHC	SHF	INPUT	Q	SHC	SHF	INPUT
21	18	4.17	2.13	0.51	1096	3.99	2.04	0.51	1151	3.83	1.96	0.51	1206	3.69	1.88	0.51	1260
21	20	4.35	1.70	0.39	1151	4.17	1.63	0.39	1219	4.05	1.58	0.39	1247	3.91	1.52	0.39	1302
22	18	4.17	2.29	0.55	1096	3.99	2.20	0.55	1151	3.83	2.11	0.55	1206	3.69	2.03	0.55	1260
22	20	4.35	1.87	0.43	1151	4.17	1.79	0.43	1219	4.05	1.74	0.43	1247	3.91	1.68	0.43	1302
22	22	4.53	1.40	0.31	1192	4.37	1.35	0.31	1267	4.26	1.32	0.31	1302	4.08	1.27	0.31	1356
23	18	4.17	2.46	0.59	1096	3.99	2.36	0.59	1151	3.83	2.26	0.59	1206	3.69	2.18	0.59	1260
23	20	4.35	2.04	0.47	1151	4.17	1.96	0.47	1219	4.05	1.90	0.47	1247	3.91	1.84	0.47	1302
23	22	4.53	1.58	0.35	1192	4.37	1.53	0.35	1267	4.26	1.49	0.35	1302	4.08	1.43	0.35	1356
24	18	4.17	2.63	0.63	1096	3.99	2.52	0.63	1151	3.83	2.42	0.63	1206	3.69	2.33	0.63	1260
24	20	4.35	2.22	0.51	1151	4.17	2.13	0.51	1219	4.05	2.06	0.51	1247	3.91	1.99	0.51	1302
24	22	4.53	1.77	0.39	1192	4.37	1.70	0.39	1267	4.26	1.66	0.39	1302	4.08	1.59	0.39	1356
24	24	4.76	1.28	0.27	1247	4.58	1.24	0.27	1315	4.47	1.21	0.27	1356	4.33	1.17	0.27	1425
25	18	4.17	2.79	0.67	1096	3.99	2.68	0.67	1151	3.83	2.57	0.67	1206	3.69	2.47	0.67	1260
25	20	4.35	2.39	0.55	1151	4.17	2.29	0.55	1219	4.05	2.23	0.55	1247	3.91	2.15	0.55	1302
25	22	4.53	1.95	0.43	1192	4.37	1.88	0.43	1267	4.26	1.83	0.43	1302	4.08	1.76	0.43	1356
25	24	4.76	1.47	0.31	1247	4.58	1.42	0.31	1315	4.47	1.39	0.31	1356	4.33	1.34	0.31	1425
26	18	4.17	2.96	0.71	1096	3.99	2.84	0.71	1151	3.83	2.72	0.71	1206	3.69	2.62	0.71	1260
26	20	4.35	2.57	0.59	1151	4.17	2.46	0.59	1219	4.05	2.39	0.59	1247	3.91	2.30	0.59	1302
26	22	4.53	2.13	0.47	1192	4.37	2.05	0.47	1267	4.26	2.00	0.47	1302	4.08	1.92	0.47	1356
26	24	4.76	1.66	0.35	1247	4.58	1.60	0.35	1315	4.47	1.57	0.35	1356	4.33	1.52	0.35	1425
26	26	4.90	1.13	0.23	1315	4.76	1.09	0.23	1384	4.69	1.08	0.23	1425	4.54	1.05	0.23	1466
27	18	4.17	3.13	0.75	1096	3.99	3.00	0.75	1151	3.83	2.88	0.75	1206	3.69	2.77	0.75	1260
27	20	4.35	2.74	0.63	1151	4.17	2.63	0.63	1219	4.05	2.55	0.63	1247	3.91	2.46	0.63	1302
27	22	4.53	2.31	0.51	1192	4.37	2.23	0.51	1267	4.26	2.17	0.51	1302	4.08	2.08	0.51	1356
27	24	4.76	1.86	0.39	1247	4.58	1.79	0.39	1315	4.47	1.74	0.39	1356	4.33	1.69	0.39	1425
27	26	4.90	1.32	0.27	1315	4.76	1.28	0.27	1384	4.69	1.27	0.27	1425	4.54	1.23	0.27	1466
28	18	4.17	3.30	0.79	1096	3.99	3.16	0.79	1151	3.83	3.03	0.79	1206	3.69	2.92	0.79	1260
28	20	4.35	2.91	0.67	1151	4.17	2.79	0.67	1219	4.05	2.71	0.67	1247	3.91	2.62	0.67	1302
28	22	4.53	2.49	0.55	1192	4.37	2.40	0.55	1267	4.26	2.34	0.55	1302	4.08	2.25	0.55	1356
28	24	4.76	2.05	0.43	1247	4.58	1.97	0.43	1315	4.47	1.92	0.43	1356	4.33	1.86	0.43	1425
28	26	4.90	1.52	0.31	1315	4.76	1.47	0.31	1384	4.69	1.45	0.31	1425	4.54	1.41	0.31	1466
29	18	4.17	3.46	0.83	1096	3.99	3.31	0.83	1151	3.83	3.18	0.83	1206	3.69	3.06	0.83	1260
29	20	4.35	3.09	0.71	1151	4.17	2.96	0.71	1219	4.05	2.87	0.71	1247	3.91	2.77	0.71	1302
29	22	4.53	2.67	0.59	1192	4.37	2.58	0.59	1267	4.26	2.51	0.59	1302	4.08	2.41	0.59	1356
29	24	4.76	2.24	0.47	1247	4.58	2.15	0.47	1315	4.47	2.10	0.47	1356	4.33	2.04	0.47	1425
29	26	4.90	1.71	0.35	1315	4.76	1.66	0.35	1384	4.69	1.64	0.35	1425	4.54	1.59	0.35	1466
30	18	4.17	3.63	0.87	1096	3.99	3.47	0.87	1151	3.83	3.34	0.87	1206	3.69	3.21	0.87	1260
30	20	4.35	3.26	0.75	1151	4.17	3.13	0.75	1219	4.05	3.04	0.75	1247	3.91	2.93	0.75	1302
30	22	4.53	2.85	0.63	1192	4.37	2.75	0.63	1267	4.26	2.68	0.63	1302	4.08	2.57	0.63	1356
30	24	4.76	2.43	0.51	1247	4.58	2.34	0.51	1315	4.47	2.28	0.51	1356	4.33	2.21	0.51	1425
30	26	4.90	1.91	0.39	1315	4.76	1.86	0.39	1384	4.69	1.83	0.39	1425	4.54	1.77	0.39	1466
31	18	4.17	3.80	0.91	1096	3.99	3.63	0.91	1151	3.83	3.49	0.91	1206	3.69	3.36	0.91	1260
31	20	4.35	3.44	0.79	1151	4.17	3.30	0.79	1219	4.05	3.20	0.79	1247	3.91	3.08	0.79	1302
31	22	4.53	3.03	0.67	1192	4.37	2.93	0.67	1267	4.26	2.85	0.67	1302	4.08	2.74	0.67	1356
31	24	4.76	2.62	0.55	1247	4.58	2.52	0.55	1315	4.47	2.46	0.55	1356	4.33	2.38	0.55	1425
31	26	4.90	2.11	0.43	1315	4.76	2.05	0.43	1384	4.69	2.01	0.43	1425	4.54	1.95	0.43	1466
32	18	4.17	3.96	0.95	1096	3.99	3.79	0.95	1151	3.83	3.64	0.95	1206	3.69	3.51	0.95	1260
32	20	4.35	3.61	0.83	1151	4.17	3.46	0.83	1219	4.05	3.36	0.83	1247	3.91	3.24	0.83	1302
32	22	4.53	3.21	0.71	1192	4.37	3.10	0.71	1267	4.26	3.02	0.71	1302	4.08	2.90	0.71	1356
32	24	4.76	2.81	0.59	1247	4.58	2.70	0.59	1315	4.47	2.64	0.59	1356	4.33	2.56	0.59	1425
32	26	4.90	2.30	0.47	1315	4.76	2.24	0.47	1384	4.69	2.20	0.47	1425	4.54	2.14	0.47	1466

**NOTE:** Q: Total capacity (kW) SHF: Sensible heat factor DB: Dry-bulb temperature  
 SHC: Sensible heat capacity (kW) INPUT: Total power input (W) WB: Wet-bulb temperature

**COOL operation (230V)  
MSC-C12TV, MU-C12TV**

CAPACITY : 3.55 kW INPUT : 1370 W SHF : 0.69

INDOOR		OUTDOOR DB (°C)															
DB (°C)	WB (°C)	35				40				43				46			
		Q	SHC	SHF	INPUT	Q	SHC	SHF	INPUT	Q	SHC	SHF	INPUT	Q	SHC	SHF	INPUT
21	18	3.48	1.77	0.51	1343	3.20	1.63	0.51	1425	3.07	1.57	0.51	1452	2.95	1.50	0.51	1480
21	20	3.66	1.43	0.39	1397	3.41	1.33	0.39	1466	3.28	1.28	0.39	1507	3.16	1.23	0.39	1548
22	18	3.48	1.91	0.55	1343	3.20	1.76	0.55	1425	3.07	1.69	0.55	1452	2.95	1.62	0.55	1480
22	20	3.66	1.57	0.43	1397	3.41	1.47	0.43	1466	3.28	1.41	0.43	1507	3.16	1.36	0.43	1548
22	22	3.87	1.20	0.31	1452	3.62	1.12	0.31	1534	3.50	1.08	0.31	1562	3.37	1.05	0.31	1589
23	18	3.48	2.05	0.59	1343	3.20	1.89	0.59	1425	3.07	1.81	0.59	1452	2.95	1.74	0.59	1480
23	20	3.66	1.72	0.47	1397	3.41	1.60	0.47	1466	3.28	1.54	0.47	1507	3.16	1.48	0.47	1548
23	22	3.87	1.35	0.35	1452	3.62	1.27	0.35	1534	3.50	1.22	0.35	1562	3.37	1.18	0.35	1589
24	18	3.48	2.19	0.63	1343	3.20	2.01	0.63	1425	3.07	1.93	0.63	1452	2.95	1.86	0.63	1480
24	20	3.66	1.86	0.51	1397	3.41	1.74	0.51	1466	3.28	1.67	0.51	1507	3.16	1.61	0.51	1548
24	22	3.87	1.51	0.39	1452	3.62	1.41	0.39	1534	3.50	1.36	0.39	1562	3.37	1.32	0.39	1589
24	24	4.08	1.10	0.27	1507	3.83	1.04	0.27	1576	3.73	1.01	0.27	1610	3.62	0.98	0.27	1644
25	18	3.48	2.33	0.67	1343	3.20	2.14	0.67	1425	3.07	2.06	0.67	1452	2.95	1.97	0.67	1480
25	20	3.66	2.01	0.55	1397	3.41	1.87	0.55	1466	3.28	1.81	0.55	1507	3.16	1.74	0.55	1548
25	22	3.87	1.66	0.43	1452	3.62	1.56	0.43	1534	3.50	1.50	0.43	1562	3.37	1.45	0.43	1589
25	24	4.08	1.27	0.31	1507	3.83	1.19	0.31	1576	3.73	1.16	0.31	1610	3.62	1.12	0.31	1644
26	18	3.48	2.47	0.71	1343	3.20	2.27	0.71	1425	3.07	2.18	0.71	1452	2.95	2.09	0.71	1480
26	20	3.66	2.16	0.59	1397	3.41	2.01	0.59	1466	3.28	1.94	0.59	1507	3.16	1.86	0.59	1548
26	22	3.87	1.82	0.47	1452	3.62	1.70	0.47	1534	3.50	1.64	0.47	1562	3.37	1.59	0.47	1589
26	24	4.08	1.43	0.35	1507	3.83	1.34	0.35	1576	3.73	1.30	0.35	1610	3.62	1.27	0.35	1644
26	26	4.30	0.99	0.23	1562	4.05	0.93	0.23	1630	3.92	0.90	0.23	1665	3.80	0.87	0.23	1699
27	18	3.48	2.61	0.75	1343	3.20	2.40	0.75	1425	3.07	2.30	0.75	1452	2.95	2.21	0.75	1480
27	20	3.66	2.30	0.63	1397	3.41	2.15	0.63	1466	3.28	2.07	0.63	1507	3.16	1.99	0.63	1548
27	22	3.87	1.97	0.51	1452	3.62	1.85	0.51	1534	3.50	1.78	0.51	1562	3.37	1.72	0.51	1589
27	24	4.08	1.59	0.39	1507	3.83	1.50	0.39	1576	3.73	1.45	0.39	1610	3.62	1.41	0.39	1644
27	26	4.30	1.16	0.27	1562	4.05	1.09	0.27	1630	3.92	1.06	0.27	1665	3.80	1.03	0.27	1699
28	18	3.48	2.75	0.79	1343	3.20	2.52	0.79	1425	3.07	2.43	0.79	1452	2.95	2.33	0.79	1480
28	20	3.66	2.45	0.67	1397	3.41	2.28	0.67	1466	3.28	2.20	0.67	1507	3.16	2.12	0.67	1548
28	22	3.87	2.13	0.55	1452	3.62	1.99	0.55	1534	3.50	1.92	0.55	1562	3.37	1.85	0.55	1589
28	24	4.08	1.76	0.43	1507	3.83	1.65	0.43	1576	3.73	1.60	0.43	1610	3.62	1.56	0.43	1644
28	26	4.30	1.33	0.31	1562	4.05	1.25	0.31	1630	3.92	1.22	0.31	1665	3.80	1.18	0.31	1699
29	18	3.48	2.89	0.83	1343	3.20	2.65	0.83	1425	3.07	2.55	0.83	1452	2.95	2.45	0.83	1480
29	20	3.66	2.60	0.71	1397	3.41	2.42	0.71	1466	3.28	2.33	0.71	1507	3.16	2.24	0.71	1548
29	22	3.87	2.28	0.59	1452	3.62	2.14	0.59	1534	3.50	2.06	0.59	1562	3.37	1.99	0.59	1589
29	24	4.08	1.92	0.47	1507	3.83	1.80	0.47	1576	3.73	1.75	0.47	1610	3.62	1.70	0.47	1644
29	26	4.30	1.50	0.35	1562	4.05	1.42	0.35	1630	3.92	1.37	0.35	1665	3.80	1.33	0.35	1699
30	18	3.48	3.03	0.87	1343	3.20	2.78	0.87	1425	3.07	2.67	0.87	1452	2.95	2.56	0.87	1480
30	20	3.66	2.74	0.75	1397	3.41	2.56	0.75	1466	3.28	2.46	0.75	1507	3.16	2.37	0.75	1548
30	22	3.87	2.44	0.63	1452	3.62	2.28	0.63	1534	3.50	2.20	0.63	1562	3.37	2.12	0.63	1589
30	24	4.08	2.08	0.51	1507	3.83	1.96	0.51	1576	3.73	1.90	0.51	1610	3.62	1.85	0.51	1644
30	26	4.30	1.68	0.39	1562	4.05	1.58	0.39	1630	3.92	1.53	0.39	1665	3.80	1.48	0.39	1699
31	18	3.48	3.17	0.91	1343	3.20	2.91	0.91	1425	3.07	2.79	0.91	1452	2.95	2.68	0.91	1480
31	20	3.66	2.89	0.79	1397	3.41	2.69	0.79	1466	3.28	2.59	0.79	1507	3.16	2.50	0.79	1548
31	22	3.87	2.59	0.67	1452	3.62	2.43	0.67	1534	3.50	2.34	0.67	1562	3.37	2.26	0.67	1589
31	24	4.08	2.25	0.55	1507	3.83	2.11	0.55	1576	3.73	2.05	0.55	1610	3.62	1.99	0.55	1644
31	26	4.30	1.85	0.43	1562	4.05	1.74	0.43	1630	3.92	1.69	0.43	1665	3.80	1.63	0.43	1699
32	18	3.48	3.31	0.95	1343	3.20	3.04	0.95	1425	3.07	2.92	0.95	1452	2.95	2.80	0.95	1480
32	20	3.66	3.03	0.83	1397	3.41	2.83	0.83	1466	3.28	2.73	0.83	1507	3.16	2.62	0.83	1548
32	22	3.87	2.75	0.71	1452	3.62	2.57	0.71	1534	3.50	2.48	0.71	1562	3.37	2.39	0.71	1589
32	24	4.08	2.41	0.59	1507	3.83	2.26	0.59	1576	3.73	2.20	0.59	1610	3.62	2.14	0.59	1644
32	26	4.30	2.02	0.47	1562	4.05	1.90	0.47	1630	3.92	1.84	0.47	1665	3.80	1.79	0.47	1699

**NOTE:** Q: Total capacity (kW) SHF: Sensible heat factor DB: Dry-bulb temperature  
 SHC: Sensible heat capacity (kW) INPUT: Total power input (W) WB: Wet-bulb temperature

WALL-MOUNTED PERFORMANCE DATA

**COOL operation (230V)  
MS-C18TV, MU-C18TV**

CAPACITY : 5.1 kW INPUT : 2100 W SHF : 0.71

		OUTDOOR DB (°C)															
INDOOR DB (°C)	INDOOR WB (°C)	21				25				27				30			
		Q	SHC	SHF	INPUT	Q	SHC	SHF	INPUT	Q	SHC	SHF	INPUT	Q	SHC	SHF	INPUT
21	18	5.99	3.18	0.53	1680	5.74	3.04	0.53	1764	5.51	2.92	0.53	1848	5.30	2.81	0.53	1932
21	20	6.25	2.56	0.41	1764	5.99	2.46	0.41	1869	5.81	2.38	0.41	1911	5.61	2.30	0.41	1995
22	18	5.99	3.42	0.57	1680	5.74	3.27	0.57	1764	5.51	3.14	0.57	1848	5.30	3.02	0.57	1932
22	20	6.25	2.81	0.45	1764	5.99	2.70	0.45	1869	5.81	2.62	0.45	1911	5.61	2.52	0.45	1995
22	22	6.50	2.15	0.33	1827	6.27	2.07	0.33	1943	6.12	2.02	0.33	1995	5.87	1.94	0.33	2079
23	18	5.99	3.66	0.61	1680	5.74	3.50	0.61	1764	5.51	3.36	0.61	1848	5.30	3.24	0.61	1932
23	20	6.25	3.06	0.49	1764	5.99	2.94	0.49	1869	5.81	2.85	0.49	1911	5.61	2.75	0.49	1995
23	22	6.50	2.41	0.37	1827	6.27	2.32	0.37	1943	6.12	2.26	0.37	1995	5.87	2.17	0.37	2079
24	18	5.99	3.90	0.65	1680	5.74	3.73	0.65	1764	5.51	3.58	0.65	1848	5.30	3.45	0.65	1932
24	20	6.25	3.31	0.53	1764	5.99	3.18	0.53	1869	5.81	3.08	0.53	1911	5.61	2.97	0.53	1995
24	22	6.50	2.67	0.41	1827	6.27	2.57	0.41	1943	6.12	2.51	0.41	1995	5.87	2.40	0.41	2079
24	24	6.83	1.98	0.29	1911	6.58	1.91	0.29	2016	6.43	1.86	0.29	2079	6.22	1.80	0.29	2184
25	18	5.99	4.13	0.69	1680	5.74	3.96	0.69	1764	5.51	3.80	0.69	1848	5.30	3.66	0.69	1932
25	20	6.25	3.56	0.57	1764	5.99	3.42	0.57	1869	5.81	3.31	0.57	1911	5.61	3.20	0.57	1995
25	22	6.50	2.93	0.45	1827	6.27	2.82	0.45	1943	6.12	2.75	0.45	1995	5.87	2.64	0.45	2079
25	24	6.83	2.26	0.33	1911	6.58	2.17	0.33	2016	6.43	2.12	0.33	2079	6.22	2.05	0.33	2184
26	18	5.99	4.37	0.73	1680	5.74	4.19	0.73	1764	5.51	4.02	0.73	1848	5.30	3.87	0.73	1932
26	20	6.25	3.81	0.61	1764	5.99	3.66	0.61	1869	5.81	3.55	0.61	1911	5.61	3.42	0.61	1995
26	22	6.50	3.19	0.49	1827	6.27	3.07	0.49	1943	6.12	3.00	0.49	1995	5.87	2.87	0.49	2079
26	24	6.83	2.53	0.37	1911	6.58	2.43	0.37	2016	6.43	2.38	0.37	2079	6.22	2.30	0.37	2184
26	26	7.04	1.76	0.25	2016	6.83	1.71	0.25	2121	6.73	1.68	0.25	2184	6.53	1.63	0.25	2247
27	18	5.99	4.61	0.77	1680	5.74	4.42	0.77	1764	5.51	4.24	0.77	1848	5.30	4.08	0.77	1932
27	20	6.25	4.06	0.65	1764	5.99	3.90	0.65	1869	5.81	3.78	0.65	1911	5.61	3.65	0.65	1995
27	22	6.50	3.45	0.53	1827	6.27	3.32	0.53	1943	6.12	3.24	0.53	1995	5.87	3.11	0.53	2079
27	24	6.83	2.80	0.41	1911	6.58	2.70	0.41	2016	6.43	2.63	0.41	2079	6.22	2.55	0.41	2184
27	26	7.04	2.04	0.29	2016	6.83	1.98	0.29	2121	6.73	1.95	0.29	2184	6.53	1.89	0.29	2247
28	18	5.99	4.85	0.81	1680	5.74	4.65	0.81	1764	5.51	4.46	0.81	1848	5.30	4.30	0.81	1932
28	20	6.25	4.31	0.69	1764	5.99	4.13	0.69	1869	5.81	4.01	0.69	1911	5.61	3.87	0.69	1995
28	22	6.50	3.71	0.57	1827	6.27	3.58	0.57	1943	6.12	3.49	0.57	1995	5.87	3.34	0.57	2079
28	24	6.83	3.08	0.45	1911	6.58	2.96	0.45	2016	6.43	2.89	0.45	2079	6.22	2.80	0.45	2184
28	26	7.04	2.32	0.33	2016	6.83	2.26	0.33	2121	6.73	2.22	0.33	2184	6.53	2.15	0.33	2247
29	18	5.99	5.09	0.85	1680	5.74	4.88	0.85	1764	5.51	4.68	0.85	1848	5.30	4.51	0.85	1932
29	20	6.25	4.56	0.73	1764	5.99	4.37	0.73	1869	5.81	4.24	0.73	1911	5.61	4.10	0.73	1995
29	22	6.50	3.97	0.61	1827	6.27	3.83	0.61	1943	6.12	3.73	0.61	1995	5.87	3.58	0.61	2079
29	24	6.83	3.35	0.49	1911	6.58	3.22	0.49	2016	6.43	3.15	0.49	2079	6.22	3.05	0.49	2184
29	26	7.04	2.60	0.37	2016	6.83	2.53	0.37	2121	6.73	2.49	0.37	2184	6.53	2.42	0.37	2247
30	18	5.99	5.33	0.89	1680	5.74	5.11	0.89	1764	5.51	4.90	0.89	1848	5.30	4.72	0.89	1932
30	20	6.25	4.81	0.77	1764	5.99	4.61	0.77	1869	5.81	4.48	0.77	1911	5.61	4.32	0.77	1995
30	22	6.50	4.23	0.65	1827	6.27	4.08	0.65	1943	6.12	3.98	0.65	1995	5.87	3.81	0.65	2079
30	24	6.83	3.62	0.53	1911	6.58	3.49	0.53	2016	6.43	3.41	0.53	2079	6.22	3.30	0.53	2184
30	26	7.04	2.89	0.41	2016	6.83	2.80	0.41	2121	6.73	2.76	0.41	2184	6.53	2.68	0.41	2247
31	18	5.99	5.57	0.93	1680	5.74	5.34	0.93	1764	5.51	5.12	0.93	1848	5.30	4.93	0.93	1932
31	20	6.25	5.06	0.81	1764	5.99	4.85	0.81	1869	5.81	4.71	0.81	1911	5.61	4.54	0.81	1995
31	22	6.50	4.49	0.69	1827	6.27	4.33	0.69	1943	6.12	4.22	0.69	1995	5.87	4.05	0.69	2079
31	24	6.83	3.90	0.57	1911	6.58	3.75	0.57	2016	6.43	3.66	0.57	2079	6.22	3.55	0.57	2184
31	26	7.04	3.17	0.45	2016	6.83	3.08	0.45	2121	6.73	3.03	0.45	2184	6.53	2.94	0.45	2247
32	18	5.99	5.81	0.97	1680	5.74	5.57	0.97	1764	5.51	5.34	0.97	1848	5.30	5.14	0.97	1932
32	20	6.25	5.31	0.85	1764	5.99	5.09	0.85	1869	5.81	4.94	0.85	1911	5.61	4.77	0.85	1995
32	22	6.50	4.75	0.73	1827	6.27	4.58	0.73	1943	6.12	4.47	0.73	1995	5.87	4.28	0.73	2079
32	24	6.83	4.17	0.61	1911	6.58	4.01	0.61	2016	6.43	3.92	0.61	2079	6.22	3.80	0.61	2184
32	26	7.04	3.45	0.49	2016	6.83	3.35	0.49	2121	6.73	3.30	0.49	2184	6.53	3.20	0.49	2247

**NOTE:** Q: Total capacity (kW) SHF: Sensible heat factor DB: Dry-bulb temperature  
 SHC: Sensible heat capacity (kW) INPUT: Total power input (W) WB: Wet-bulb temperature



**COOL operation (230V)  
MS-C18TV, MU-C18TV**

CAPACITY : 5.1 kW INPUT : 2100 W SHF : 0.71

		OUTDOOR DB (°C)															
INDOOR DB (°C)	INDOOR WB (°C)	35				40				43				46			
		Q	SHC	SHF	INPUT	Q	SHC	SHF	INPUT	Q	SHC	SHF	INPUT	Q	SHC	SHF	INPUT
21	18	5.00	2.65	0.53	2058	4.59	2.43	0.53	2184	4.41	2.34	0.53	2226	4.23	2.24	0.53	2268
21	20	5.25	2.15	0.41	2142	4.90	2.01	0.41	2247	4.72	1.93	0.41	2310	4.54	1.86	0.41	2373
22	18	5.00	2.85	0.57	2058	4.59	2.62	0.57	2184	4.41	2.51	0.57	2226	4.23	2.41	0.57	2268
22	20	5.25	2.36	0.45	2142	4.90	2.20	0.45	2247	4.72	2.12	0.45	2310	4.54	2.04	0.45	2373
22	22	5.56	1.83	0.33	2226	5.20	1.72	0.33	2352	5.02	1.66	0.33	2394	4.85	1.60	0.33	2436
23	18	5.00	3.05	0.61	2058	4.59	2.80	0.61	2184	4.41	2.69	0.61	2226	4.23	2.58	0.61	2268
23	20	5.25	2.57	0.49	2142	4.90	2.40	0.49	2247	4.72	2.31	0.49	2310	4.54	2.22	0.49	2373
23	22	5.56	2.06	0.37	2226	5.20	1.92	0.37	2352	5.02	1.86	0.37	2394	4.85	1.79	0.37	2436
24	18	5.00	3.25	0.65	2058	4.59	2.98	0.65	2184	4.41	2.87	0.65	2226	4.23	2.75	0.65	2268
24	20	5.25	2.78	0.53	2142	4.90	2.59	0.53	2247	4.72	2.50	0.53	2310	4.54	2.41	0.53	2373
24	22	5.56	2.28	0.41	2226	5.20	2.13	0.41	2352	5.02	2.06	0.41	2394	4.85	1.99	0.41	2436
24	24	5.87	1.70	0.29	2310	5.51	1.60	0.29	2415	5.36	1.55	0.29	2468	5.20	1.51	0.29	2520
25	18	5.00	3.45	0.69	2058	4.59	3.17	0.69	2184	4.41	3.04	0.69	2226	4.23	2.92	0.69	2268
25	20	5.25	2.99	0.57	2142	4.90	2.79	0.57	2247	4.72	2.69	0.57	2310	4.54	2.59	0.57	2373
25	22	5.56	2.50	0.45	2226	5.20	2.34	0.45	2352	5.02	2.26	0.45	2394	4.85	2.18	0.45	2436
25	24	5.87	1.94	0.33	2310	5.51	1.82	0.33	2415	5.36	1.77	0.33	2468	5.20	1.72	0.33	2520
26	18	5.00	3.65	0.73	2058	4.59	3.35	0.73	2184	4.41	3.22	0.73	2226	4.23	3.09	0.73	2268
26	20	5.25	3.20	0.61	2142	4.90	2.99	0.61	2247	4.72	2.88	0.61	2310	4.54	2.77	0.61	2373
26	22	5.56	2.72	0.49	2226	5.20	2.55	0.49	2352	5.02	2.46	0.49	2394	4.85	2.37	0.49	2436
26	24	5.87	2.17	0.37	2310	5.51	2.04	0.37	2415	5.36	1.98	0.37	2468	5.20	1.92	0.37	2520
26	26	6.17	1.54	0.25	2394	5.81	1.45	0.25	2499	5.64	1.41	0.25	2552	5.46	1.36	0.25	2604
27	18	5.00	3.85	0.77	2058	4.59	3.53	0.77	2184	4.41	3.40	0.77	2226	4.23	3.26	0.77	2268
27	20	5.25	3.41	0.65	2142	4.90	3.18	0.65	2247	4.72	3.07	0.65	2310	4.54	2.95	0.65	2373
27	22	5.56	2.95	0.53	2226	5.20	2.76	0.53	2352	5.02	2.66	0.53	2394	4.85	2.57	0.53	2436
27	24	5.87	2.40	0.41	2310	5.51	2.26	0.41	2415	5.36	2.20	0.41	2468	5.20	2.13	0.41	2520
27	26	6.17	1.79	0.29	2394	5.81	1.69	0.29	2499	5.64	1.63	0.29	2552	5.46	1.58	0.29	2604
28	18	5.00	4.05	0.81	2058	4.59	3.72	0.81	2184	4.41	3.57	0.81	2226	4.23	3.43	0.81	2268
28	20	5.25	3.62	0.69	2142	4.90	3.38	0.69	2247	4.72	3.26	0.69	2310	4.54	3.13	0.69	2373
28	22	5.56	3.17	0.57	2226	5.20	2.97	0.57	2352	5.02	2.86	0.57	2394	4.85	2.76	0.57	2436
28	24	5.87	2.64	0.45	2310	5.51	2.48	0.45	2415	5.36	2.41	0.45	2468	5.20	2.34	0.45	2520
28	26	6.17	2.04	0.33	2394	5.81	1.92	0.33	2499	5.64	1.86	0.33	2552	5.46	1.80	0.33	2604
29	18	5.00	4.25	0.85	2058	4.59	3.90	0.85	2184	4.41	3.75	0.85	2226	4.23	3.60	0.85	2268
29	20	5.25	3.83	0.73	2142	4.90	3.57	0.73	2247	4.72	3.44	0.73	2310	4.54	3.31	0.73	2373
29	22	5.56	3.39	0.61	2226	5.20	3.17	0.61	2352	5.02	3.06	0.61	2394	4.85	2.96	0.61	2436
29	24	5.87	2.87	0.49	2310	5.51	2.70	0.49	2415	5.36	2.62	0.49	2468	5.20	2.55	0.49	2520
29	26	6.17	2.28	0.37	2394	5.81	2.15	0.37	2499	5.64	2.09	0.37	2552	5.46	2.02	0.37	2604
30	18	5.00	4.45	0.89	2058	4.59	4.09	0.89	2184	4.41	3.93	0.89	2226	4.23	3.77	0.89	2268
30	20	5.25	4.04	0.77	2142	4.90	3.77	0.77	2247	4.72	3.63	0.77	2310	4.54	3.50	0.77	2373
30	22	5.56	3.61	0.65	2226	5.20	3.38	0.65	2352	5.02	3.27	0.65	2394	4.85	3.15	0.65	2436
30	24	5.87	3.11	0.53	2310	5.51	2.92	0.53	2415	5.36	2.84	0.53	2468	5.20	2.76	0.53	2520
30	26	6.17	2.53	0.41	2394	5.81	2.38	0.41	2499	5.64	2.31	0.41	2552	5.46	2.24	0.41	2604
31	18	5.00	4.65	0.93	2058	4.59	4.27	0.93	2184	4.41	4.10	0.93	2226	4.23	3.94	0.93	2268
31	20	5.25	4.25	0.81	2142	4.90	3.97	0.81	2247	4.72	3.82	0.81	2310	4.54	3.68	0.81	2373
31	22	5.56	3.84	0.69	2226	5.20	3.59	0.69	2352	5.02	3.47	0.69	2394	4.85	3.34	0.69	2436
31	24	5.87	3.34	0.57	2310	5.51	3.14	0.57	2415	5.36	3.05	0.57	2468	5.20	2.97	0.57	2520
31	26	6.17	2.78	0.45	2394	5.81	2.62	0.45	2499	5.64	2.54	0.45	2552	5.46	2.46	0.45	2604
32	18	5.00	4.85	0.97	2058	4.59	4.45	0.97	2184	4.41	4.28	0.97	2226	4.23	4.11	0.97	2268
32	20	5.25	4.47	0.85	2142	4.90	4.16	0.85	2247	4.72	4.01	0.85	2310	4.54	3.86	0.85	2373
32	22	5.56	4.06	0.73	2226	5.20	3.80	0.73	2352	5.02	3.67	0.73	2394	4.85	3.54	0.73	2436
32	24	5.87	3.58	0.61	2310	5.51	3.36	0.61	2415	5.36	3.27	0.61	2468	5.20	3.17	0.61	2520
32	26	6.17	3.02	0.49	2394	5.81	2.85	0.49	2499	5.64	2.76	0.49	2552	5.46	2.67	0.49	2604

**NOTE:** Q: Total capacity (kW) SHF: Sensible heat factor DB: Dry-bulb temperature  
SHC: Sensible heat capacity (kW) INPUT: Total power input (W) WB: Wet-bulb temperature

PERFORMANCE DATA

WALL-MOUNTED

**COOL operation (230V)  
MS-C24TV, MU-C24TV**

CAPACITY : 6.4 kW INPUT : 2840 W SHF : 0.66

		OUTDOOR DB (°C)															
INDOOR DB (°C)	INDOOR WB (°C)	21				25				27				30			
		Q	SHC	SHF	INPUT	Q	SHC	SHF	INPUT	Q	SHC	SHF	INPUT	Q	SHC	SHF	INPUT
21	18	7.52	3.61	0.48	2272	7.20	3.46	0.48	2386	6.91	3.32	0.48	2499	6.66	3.19	0.48	2613
21	20	7.84	2.82	0.36	2386	7.52	2.71	0.36	2528	7.30	2.63	0.36	2584	7.04	2.53	0.36	2698
22	18	7.52	3.91	0.52	2272	7.20	3.74	0.52	2386	6.91	3.59	0.52	2499	6.66	3.46	0.52	2613
22	20	7.84	3.14	0.40	2386	7.52	3.01	0.40	2528	7.30	2.92	0.40	2584	7.04	2.82	0.40	2698
22	22	8.16	2.28	0.28	2471	7.87	2.20	0.28	2627	7.68	2.15	0.28	2698	7.36	2.06	0.28	2812
23	18	7.52	4.21	0.56	2272	7.20	4.03	0.56	2386	6.91	3.87	0.56	2499	6.66	3.73	0.56	2613
23	20	7.84	3.45	0.44	2386	7.52	3.31	0.44	2528	7.30	3.21	0.44	2584	7.04	3.10	0.44	2698
23	22	8.16	2.61	0.32	2471	7.87	2.52	0.32	2627	7.68	2.46	0.32	2698	7.36	2.36	0.32	2812
24	18	7.52	4.51	0.60	2272	7.20	4.32	0.60	2386	6.91	4.15	0.60	2499	6.66	3.99	0.60	2613
24	20	7.84	3.76	0.48	2386	7.52	3.61	0.48	2528	7.30	3.50	0.48	2584	7.04	3.38	0.48	2698
24	22	8.16	2.94	0.36	2471	7.87	2.83	0.36	2627	7.68	2.76	0.36	2698	7.36	2.65	0.36	2812
24	24	8.58	2.06	0.24	2584	8.26	1.98	0.24	2726	8.06	1.94	0.24	2812	7.81	1.87	0.24	2954
25	18	7.52	4.81	0.64	2272	7.20	4.61	0.64	2386	6.91	4.42	0.64	2499	6.66	4.26	0.64	2613
25	20	7.84	4.08	0.52	2386	7.52	3.91	0.52	2528	7.30	3.79	0.52	2584	7.04	3.66	0.52	2698
25	22	8.16	3.26	0.40	2471	7.87	3.15	0.40	2627	7.68	3.07	0.40	2698	7.36	2.94	0.40	2812
25	24	8.58	2.40	0.28	2584	8.26	2.31	0.28	2726	8.06	2.26	0.28	2812	7.81	2.19	0.28	2954
26	18	7.52	5.11	0.68	2272	7.20	4.90	0.68	2386	6.91	4.70	0.68	2499	6.66	4.53	0.68	2613
26	20	7.84	4.39	0.56	2386	7.52	4.21	0.56	2528	7.30	4.09	0.56	2584	7.04	3.94	0.56	2698
26	22	8.16	3.59	0.44	2471	7.87	3.46	0.44	2627	7.68	3.38	0.44	2698	7.36	3.24	0.44	2812
26	24	8.58	2.74	0.32	2584	8.26	2.64	0.32	2726	8.06	2.58	0.32	2812	7.81	2.50	0.32	2954
26	26	8.83	1.77	0.20	2726	8.58	1.72	0.20	2868	8.45	1.69	0.20	2954	8.19	1.64	0.20	3039
27	18	7.52	5.41	0.72	2272	7.20	5.18	0.72	2386	6.91	4.98	0.72	2499	6.66	4.79	0.72	2613
27	20	7.84	4.70	0.60	2386	7.52	4.51	0.60	2528	7.30	4.38	0.60	2584	7.04	4.22	0.60	2698
27	22	8.16	3.92	0.48	2471	7.87	3.78	0.48	2627	7.68	3.69	0.48	2698	7.36	3.53	0.48	2812
27	24	8.58	3.09	0.36	2584	8.26	2.97	0.36	2726	8.06	2.90	0.36	2812	7.81	2.81	0.36	2954
27	26	8.83	2.12	0.24	2726	8.58	2.06	0.24	2868	8.45	2.03	0.24	2954	8.19	1.97	0.24	3039
28	18	7.52	5.72	0.76	2272	7.20	5.47	0.76	2386	6.91	5.25	0.76	2499	6.66	5.06	0.76	2613
28	20	7.84	5.02	0.64	2386	7.52	4.81	0.64	2528	7.30	4.67	0.64	2584	7.04	4.51	0.64	2698
28	22	8.16	4.24	0.52	2471	7.87	4.09	0.52	2627	7.68	3.99	0.52	2698	7.36	3.83	0.52	2812
28	24	8.58	3.43	0.40	2584	8.26	3.30	0.40	2726	8.06	3.23	0.40	2812	7.81	3.12	0.40	2954
28	26	8.83	2.47	0.28	2726	8.58	2.40	0.28	2868	8.45	2.37	0.28	2954	8.19	2.29	0.28	3039
29	18	7.52	6.02	0.80	2272	7.20	5.76	0.80	2386	6.91	5.53	0.80	2499	6.66	5.32	0.80	2613
29	20	7.84	5.33	0.68	2386	7.52	5.11	0.68	2528	7.30	4.96	0.68	2584	7.04	4.79	0.68	2698
29	22	8.16	4.57	0.56	2471	7.87	4.41	0.56	2627	7.68	4.30	0.56	2698	7.36	4.12	0.56	2812
29	24	8.58	3.77	0.44	2584	8.26	3.63	0.44	2726	8.06	3.55	0.44	2812	7.81	3.44	0.44	2954
29	26	8.83	2.83	0.32	2726	8.58	2.74	0.32	2868	8.45	2.70	0.32	2954	8.19	2.62	0.32	3039
30	18	7.52	6.32	0.84	2272	7.20	6.05	0.84	2386	6.91	5.81	0.84	2499	6.66	5.59	0.84	2613
30	20	7.84	5.64	0.72	2386	7.52	5.41	0.72	2528	7.30	5.25	0.72	2584	7.04	5.07	0.72	2698
30	22	8.16	4.90	0.60	2471	7.87	4.72	0.60	2627	7.68	4.61	0.60	2698	7.36	4.42	0.60	2812
30	24	8.58	4.12	0.48	2584	8.26	3.96	0.48	2726	8.06	3.87	0.48	2812	7.81	3.75	0.48	2954
30	26	8.83	3.18	0.36	2726	8.58	3.09	0.36	2868	8.45	3.04	0.36	2954	8.19	2.95	0.36	3039
31	18	7.52	6.62	0.88	2272	7.20	6.34	0.88	2386	6.91	6.08	0.88	2499	6.66	5.86	0.88	2613
31	20	7.84	5.96	0.76	2386	7.52	5.72	0.76	2528	7.30	5.54	0.76	2584	7.04	5.35	0.76	2698
31	22	8.16	5.22	0.64	2471	7.87	5.04	0.64	2627	7.68	4.92	0.64	2698	7.36	4.71	0.64	2812
31	24	8.58	4.46	0.52	2584	8.26	4.29	0.52	2726	8.06	4.19	0.52	2812	7.81	4.06	0.52	2954
31	26	8.83	3.53	0.40	2726	8.58	3.43	0.40	2868	8.45	3.38	0.40	2954	8.19	3.28	0.40	3039
32	18	7.52	6.92	0.92	2272	7.20	6.62	0.92	2386	6.91	6.36	0.92	2499	6.66	6.12	0.92	2613
32	20	7.84	6.27	0.80	2386	7.52	6.02	0.80	2528	7.30	5.84	0.80	2584	7.04	5.63	0.80	2698
32	22	8.16	5.55	0.68	2471	7.87	5.35	0.68	2627	7.68	5.22	0.68	2698	7.36	5.00	0.68	2812
32	24	8.58	4.80	0.56	2584	8.26	4.62	0.56	2726	8.06	4.52	0.56	2812	7.81	4.37	0.56	2954
32	26	8.83	3.89	0.44	2726	8.58	3.77	0.44	2868	8.45	3.72	0.44	2954	8.19	3.60	0.44	3039

**NOTE:** Q: Total capacity (kW) SHF: Sensible heat factor DB: Dry-bulb temperature  
 SHC: Sensible heat capacity (kW) INPUT: Total power input (W) WB: Wet-bulb temperature

**COOL operation (230V)  
MS-C24TV, MU-C24TV**

CAPACITY : 6.4 kW INPUT : 2840 W SHF : 0.66

		OUTDOOR DB (°C)															
INDOOR DB (°C)	INDOOR WB (°C)	35				40				43				46			
		Q	SHC	SHF	INPUT	Q	SHC	SHF	INPUT	Q	SHC	SHF	INPUT	Q	SHC	SHF	INPUT
21	18	6.27	3.01	0.48	2783	5.76	2.76	0.48	2954	5.54	2.66	0.48	3010	5.31	2.55	0.48	3067
21	20	6.59	2.37	0.36	2897	6.14	2.21	0.36	3039	5.92	2.13	0.36	3124	5.70	2.05	0.36	3209
22	18	6.27	3.26	0.52	2783	5.76	3.00	0.52	2954	5.54	2.88	0.52	3010	5.31	2.76	0.52	3067
22	20	6.59	2.64	0.40	2897	6.14	2.46	0.40	3039	5.92	2.37	0.40	3124	5.70	2.28	0.40	3209
22	22	6.98	1.95	0.28	3010	6.53	1.83	0.28	3181	6.30	1.77	0.28	3238	6.08	1.70	0.28	3294
23	18	6.27	3.51	0.56	2783	5.76	3.23	0.56	2954	5.54	3.10	0.56	3010	5.31	2.97	0.56	3067
23	20	6.59	2.90	0.44	2897	6.14	2.70	0.44	3039	5.92	2.60	0.44	3124	5.70	2.51	0.44	3209
23	22	6.98	2.23	0.32	3010	6.53	2.09	0.32	3181	6.30	2.02	0.32	3238	6.08	1.95	0.32	3294
24	18	6.27	3.76	0.60	2783	5.76	3.46	0.60	2954	5.54	3.32	0.60	3010	5.31	3.19	0.60	3067
24	20	6.59	3.16	0.48	2897	6.14	2.95	0.48	3039	5.92	2.84	0.48	3124	5.70	2.73	0.48	3209
24	22	6.98	2.51	0.36	3010	6.53	2.35	0.36	3181	6.30	2.27	0.36	3238	6.08	2.19	0.36	3294
24	24	7.36	1.77	0.24	3124	6.91	1.66	0.24	3266	6.72	1.61	0.24	3337	6.53	1.57	0.24	3408
25	18	6.27	4.01	0.64	2783	5.76	3.69	0.64	2954	5.54	3.54	0.64	3010	5.31	3.40	0.64	3067
25	20	6.59	3.43	0.52	2897	6.14	3.19	0.52	3039	5.92	3.08	0.52	3124	5.70	2.96	0.52	3209
25	22	6.98	2.79	0.40	3010	6.53	2.61	0.40	3181	6.30	2.52	0.40	3238	6.08	2.43	0.40	3294
25	24	7.36	2.06	0.28	3124	6.91	1.94	0.28	3266	6.72	1.88	0.28	3337	6.53	1.83	0.28	3408
26	18	6.27	4.26	0.68	2783	5.76	3.92	0.68	2954	5.54	3.76	0.68	3010	5.31	3.61	0.68	3067
26	20	6.59	3.69	0.56	2897	6.14	3.44	0.56	3039	5.92	3.32	0.56	3124	5.70	3.19	0.56	3209
26	22	6.98	3.07	0.44	3010	6.53	2.87	0.44	3181	6.30	2.77	0.44	3238	6.08	2.68	0.44	3294
26	24	7.36	2.36	0.32	3124	6.91	2.21	0.32	3266	6.72	2.15	0.32	3337	6.53	2.09	0.32	3408
26	26	7.74	1.55	0.20	3238	7.30	1.46	0.20	3380	7.07	1.41	0.20	3451	6.85	1.37	0.20	3522
27	18	6.27	4.52	0.72	2783	5.76	4.15	0.72	2954	5.54	3.99	0.72	3010	5.31	3.82	0.72	3067
27	20	6.59	3.96	0.60	2897	6.14	3.69	0.60	3039	5.92	3.55	0.60	3124	5.70	3.42	0.60	3209
27	22	6.98	3.35	0.48	3010	6.53	3.13	0.48	3181	6.30	3.03	0.48	3238	6.08	2.92	0.48	3294
27	24	7.36	2.65	0.36	3124	6.91	2.49	0.36	3266	6.72	2.42	0.36	3337	6.53	2.35	0.36	3408
27	26	7.74	1.86	0.24	3238	7.30	1.75	0.24	3380	7.07	1.70	0.24	3451	6.85	1.64	0.24	3522
28	18	6.27	4.77	0.76	2783	5.76	4.38	0.76	2954	5.54	4.21	0.76	3010	5.31	4.04	0.76	3067
28	20	6.59	4.22	0.64	2897	6.14	3.93	0.64	3039	5.92	3.79	0.64	3124	5.70	3.65	0.64	3209
28	22	6.98	3.63	0.52	3010	6.53	3.39	0.52	3181	6.30	3.28	0.52	3238	6.08	3.16	0.52	3294
28	24	7.36	2.94	0.40	3124	6.91	2.76	0.40	3266	6.72	2.69	0.40	3337	6.53	2.61	0.40	3408
28	26	7.74	2.17	0.28	3238	7.30	2.04	0.28	3380	7.07	1.98	0.28	3451	6.85	1.92	0.28	3522
29	18	6.27	5.02	0.80	2783	5.76	4.61	0.80	2954	5.54	4.43	0.80	3010	5.31	4.25	0.80	3067
29	20	6.59	4.48	0.68	2897	6.14	4.18	0.68	3039	5.92	4.03	0.68	3124	5.70	3.87	0.68	3209
29	22	6.98	3.91	0.56	3010	6.53	3.66	0.56	3181	6.30	3.53	0.56	3238	6.08	3.40	0.56	3294
29	24	7.36	3.24	0.44	3124	6.91	3.04	0.44	3266	6.72	2.96	0.44	3337	6.53	2.87	0.44	3408
29	26	7.74	2.48	0.32	3238	7.30	2.33	0.32	3380	7.07	2.26	0.32	3451	6.85	2.19	0.32	3522
30	18	6.27	5.27	0.84	2783	5.76	4.84	0.84	2954	5.54	4.65	0.84	3010	5.31	4.46	0.84	3067
30	20	6.59	4.75	0.72	2897	6.14	4.42	0.72	3039	5.92	4.26	0.72	3124	5.70	4.10	0.72	3209
30	22	6.98	4.19	0.60	3010	6.53	3.92	0.60	3181	6.30	3.78	0.60	3238	6.08	3.65	0.60	3294
30	24	7.36	3.53	0.48	3124	6.91	3.32	0.48	3266	6.72	3.23	0.48	3337	6.53	3.13	0.48	3408
30	26	7.74	2.79	0.36	3238	7.30	2.63	0.36	3380	7.07	2.55	0.36	3451	6.85	2.47	0.36	3522
31	18	6.27	5.52	0.88	2783	5.76	5.07	0.88	2954	5.54	4.87	0.88	3010	5.31	4.67	0.88	3067
31	20	6.59	5.01	0.76	2897	6.14	4.67	0.76	3039	5.92	4.50	0.76	3124	5.70	4.33	0.76	3209
31	22	6.98	4.46	0.64	3010	6.53	4.18	0.64	3181	6.30	4.03	0.64	3238	6.08	3.89	0.64	3294
31	24	7.36	3.83	0.52	3124	6.91	3.59	0.52	3266	6.72	3.49	0.52	3337	6.53	3.39	0.52	3408
31	26	7.74	3.10	0.40	3238	7.30	2.92	0.40	3380	7.07	2.83	0.40	3451	6.85	2.74	0.40	3522
32	18	6.27	5.77	0.92	2783	5.76	5.30	0.92	2954	5.54	5.09	0.92	3010	5.31	4.89	0.92	3067
32	20	6.59	5.27	0.80	2897	6.14	4.92	0.80	3039	5.92	4.74	0.80	3124	5.70	4.56	0.80	3209
32	22	6.98	4.74	0.68	3010	6.53	4.44	0.68	3181	6.30	4.29	0.68	3238	6.08	4.13	0.68	3294
32	24	7.36	4.12	0.56	3124	6.91	3.87	0.56	3266	6.72	3.76	0.56	3337	6.53	3.66	0.56	3408
32	26	7.74	3.41	0.44	3238	7.30	3.21	0.44	3380	7.07	3.11	0.44	3451	6.85	3.01	0.44	3522

**NOTE:** Q: Total capacity (kW) SHF: Sensible heat factor DB: Dry-bulb temperature  
 SHC: Sensible heat capacity (kW) INPUT: Total power input (W) WB: Wet-bulb temperature

WALL-MOUNTED PERFORMANCE DATA

**B.1.6.2 Heat Pump**

**COOL operation (230V)  
MSC-C07TV, MUH-C07TV**

CAPACITY : 2.20 kW INPUT : 770 W SHF : 0.77

		OUTDOOR DB (°C)															
INDOOR DB (°C)	INDOOR WB (°C)	21				25				27				30			
		Q	SHC	SHF	INPUT	Q	SHC	SHF	INPUT	Q	SHC	SHF	INPUT	Q	SHC	SHF	INPUT
21	18	2.59	1.53	0.59	616	2.48	1.46	0.59	647	2.38	1.40	0.59	678	2.29	1.35	0.59	708
21	20	2.70	1.27	0.47	647	2.59	1.21	0.47	685	2.51	1.18	0.47	701	2.42	1.14	0.47	732
22	18	2.59	1.63	0.63	616	2.48	1.56	0.63	647	2.38	1.50	0.63	678	2.29	1.44	0.63	708
22	20	2.70	1.37	0.51	647	2.59	1.32	0.51	685	2.51	1.28	0.51	701	2.42	1.23	0.51	732
22	22	2.81	1.09	0.39	670	2.71	1.06	0.39	712	2.64	1.03	0.39	732	2.53	0.99	0.39	762
23	18	2.59	1.73	0.67	616	2.48	1.66	0.67	647	2.38	1.59	0.67	678	2.29	1.53	0.67	708
23	20	2.70	1.48	0.55	647	2.59	1.42	0.55	685	2.51	1.38	0.55	701	2.42	1.33	0.55	732
23	22	2.81	1.21	0.43	670	2.71	1.16	0.43	712	2.64	1.14	0.43	732	2.53	1.09	0.43	762
24	18	2.59	1.84	0.71	616	2.48	1.76	0.71	647	2.38	1.69	0.71	678	2.29	1.62	0.71	708
24	20	2.70	1.59	0.59	647	2.59	1.53	0.59	685	2.51	1.48	0.59	701	2.42	1.43	0.59	732
24	22	2.81	1.32	0.47	670	2.71	1.27	0.47	712	2.64	1.24	0.47	732	2.53	1.19	0.47	762
24	24	2.95	1.03	0.35	701	2.84	0.99	0.35	739	2.77	0.97	0.35	762	2.68	0.94	0.35	801
25	18	2.59	1.94	0.75	616	2.48	1.86	0.75	647	2.38	1.78	0.75	678	2.29	1.72	0.75	708
25	20	2.70	1.70	0.63	647	2.59	1.63	0.63	685	2.51	1.58	0.63	701	2.42	1.52	0.63	732
25	22	2.81	1.43	0.51	670	2.71	1.38	0.51	712	2.64	1.35	0.51	732	2.53	1.29	0.51	762
25	24	2.95	1.15	0.39	701	2.84	1.11	0.39	739	2.77	1.08	0.39	762	2.68	1.05	0.39	801
26	18	2.59	2.04	0.79	616	2.48	1.96	0.79	647	2.38	1.88	0.79	678	2.29	1.81	0.79	708
26	20	2.70	1.81	0.67	647	2.59	1.73	0.67	685	2.51	1.68	0.67	701	2.42	1.62	0.67	732
26	22	2.81	1.54	0.55	670	2.71	1.49	0.55	712	2.64	1.45	0.55	732	2.53	1.39	0.55	762
26	24	2.95	1.27	0.43	701	2.84	1.22	0.43	739	2.77	1.19	0.43	762	2.68	1.15	0.43	801
26	26	3.04	0.94	0.31	739	2.95	0.91	0.31	778	2.90	0.90	0.31	801	2.82	0.87	0.31	824
27	18	2.59	2.15	0.83	616	2.48	2.05	0.83	647	2.38	1.97	0.83	678	2.29	1.90	0.83	708
27	20	2.70	1.91	0.71	647	2.59	1.84	0.71	685	2.51	1.78	0.71	701	2.42	1.72	0.71	732
27	22	2.81	1.65	0.59	670	2.71	1.60	0.59	712	2.64	1.56	0.59	732	2.53	1.49	0.59	762
27	24	2.95	1.39	0.47	701	2.84	1.33	0.47	739	2.77	1.30	0.47	762	2.68	1.26	0.47	801
27	26	3.04	1.06	0.35	739	2.95	1.03	0.35	778	2.90	1.02	0.35	801	2.82	0.99	0.35	824
28	18	2.59	2.25	0.87	616	2.48	2.15	0.87	647	2.38	2.07	0.87	678	2.29	1.99	0.87	708
28	20	2.70	2.02	0.75	647	2.59	1.94	0.75	685	2.51	1.88	0.75	701	2.42	1.82	0.75	732
28	22	2.81	1.77	0.63	670	2.71	1.70	0.63	712	2.64	1.66	0.63	732	2.53	1.59	0.63	762
28	24	2.95	1.50	0.51	701	2.84	1.45	0.51	739	2.77	1.41	0.51	762	2.68	1.37	0.51	801
28	26	3.04	1.18	0.39	739	2.95	1.15	0.39	778	2.90	1.13	0.39	801	2.82	1.10	0.39	824
29	18	2.59	2.35	0.91	616	2.48	2.25	0.91	647	2.38	2.16	0.91	678	2.29	2.08	0.91	708
29	20	2.70	2.13	0.79	647	2.59	2.04	0.79	685	2.51	1.98	0.79	701	2.42	1.91	0.79	732
29	22	2.81	1.88	0.67	670	2.71	1.81	0.67	712	2.64	1.77	0.67	732	2.53	1.70	0.67	762
29	24	2.95	1.62	0.55	701	2.84	1.56	0.55	739	2.77	1.52	0.55	762	2.68	1.48	0.55	801
29	26	3.04	1.31	0.43	739	2.95	1.27	0.43	778	2.90	1.25	0.43	801	2.82	1.21	0.43	824
30	18	2.59	2.46	0.95	616	2.48	2.35	0.95	647	2.38	2.26	0.95	678	2.29	2.17	0.95	708
30	20	2.70	2.24	0.83	647	2.59	2.15	0.83	685	2.51	2.08	0.83	701	2.42	2.01	0.83	732
30	22	2.81	1.99	0.71	670	2.71	1.92	0.71	712	2.64	1.87	0.71	732	2.53	1.80	0.71	762
30	24	2.95	1.74	0.59	701	2.84	1.67	0.59	739	2.77	1.64	0.59	762	2.68	1.58	0.59	801
30	26	3.04	1.43	0.47	739	2.95	1.39	0.47	778	2.90	1.36	0.47	801	2.82	1.32	0.47	824
31	18	2.59	2.56	0.99	616	2.48	2.45	0.99	647	2.38	2.35	0.99	678	2.29	2.27	0.99	708
31	20	2.70	2.34	0.87	647	2.59	2.25	0.87	685	2.51	2.18	0.87	701	2.42	2.11	0.87	732
31	22	2.81	2.10	0.75	670	2.71	2.03	0.75	712	2.64	1.98	0.75	732	2.53	1.90	0.75	762
31	24	2.95	1.86	0.63	701	2.84	1.79	0.63	739	2.77	1.75	0.63	762	2.68	1.69	0.63	801
31	26	3.04	1.55	0.51	739	2.95	1.50	0.51	778	2.90	1.48	0.51	801	2.82	1.44	0.51	824
32	18	2.59	2.66	1.03	616	2.48	2.55	1.03	647	2.38	2.45	1.03	678	2.29	2.36	1.03	708
32	20	2.70	2.45	0.91	647	2.59	2.35	0.91	685	2.51	2.28	0.91	701	2.42	2.20	0.91	732
32	22	2.81	2.22	0.79	670	2.71	2.14	0.79	712	2.64	2.09	0.79	732	2.53	2.00	0.79	762
32	24	2.95	1.98	0.67	701	2.84	1.90	0.67	739	2.77	1.86	0.67	762	2.68	1.80	0.67	801
32	26	3.04	1.67	0.55	739	2.95	1.62	0.55	778	2.90	1.60	0.55	801	2.82	1.55	0.55	824

**NOTE:** Q: Total capacity (kW) SHF: Sensible heat factor DB: Dry-bulb temperature  
 SHC: Sensible heat capacity (kW) INPUT: Total power input (W) WB: Wet-bulb temperature

**COOL operation (230V)  
MSC-C07TV, MUH-C07TV**

CAPACITY : 2.20 kW INPUT : 770 W SHF : 0.77

		OUTDOOR DB (°C)															
INDOOR DB (°C)	INDOOR WB (°C)	35				40				43				46			
		Q	SHC	SHF	INPUT	Q	SHC	SHF	INPUT	Q	SHC	SHF	INPUT	Q	SHC	SHF	INPUT
21	18	2.16	1.27	0.59	755	1.98	1.17	0.59	801	1.90	1.12	0.59	816	1.83	1.08	0.59	832
21	20	2.27	1.07	0.47	785	2.11	0.99	0.47	824	2.04	0.96	0.47	847	1.96	0.92	0.47	870
22	18	2.16	1.36	0.63	755	1.98	1.25	0.63	801	1.90	1.20	0.63	816	1.83	1.15	0.63	832
22	20	2.27	1.16	0.51	785	2.11	1.08	0.51	824	2.04	1.04	0.51	847	1.96	1.00	0.51	870
22	22	2.40	0.94	0.39	816	2.24	0.88	0.39	862	2.17	0.85	0.39	878	2.09	0.82	0.39	893
23	18	2.16	1.44	0.67	755	1.98	1.33	0.67	801	1.90	1.28	0.67	816	1.83	1.22	0.67	832
23	20	2.27	1.25	0.55	785	2.11	1.16	0.55	824	2.04	1.12	0.55	847	1.96	1.08	0.55	870
23	22	2.40	1.03	0.43	816	2.24	0.96	0.43	862	2.17	0.93	0.43	878	2.09	0.90	0.43	893
24	18	2.16	1.53	0.71	755	1.98	1.41	0.71	801	1.90	1.35	0.71	816	1.83	1.30	0.71	832
24	20	2.27	1.34	0.59	785	2.11	1.25	0.59	824	2.04	1.20	0.59	847	1.96	1.16	0.59	870
24	22	2.40	1.13	0.47	816	2.24	1.05	0.47	862	2.17	1.02	0.47	878	2.09	0.98	0.47	893
24	24	2.53	0.89	0.35	847	2.38	0.83	0.35	886	2.31	0.81	0.35	905	2.24	0.79	0.35	924
25	18	2.16	1.62	0.75	755	1.98	1.49	0.75	801	1.90	1.43	0.75	816	1.83	1.37	0.75	832
25	20	2.27	1.43	0.63	785	2.11	1.33	0.63	824	2.04	1.28	0.63	847	1.96	1.23	0.63	870
25	22	2.40	1.22	0.51	816	2.24	1.14	0.51	862	2.17	1.11	0.51	878	2.09	1.07	0.51	893
25	24	2.53	0.99	0.39	847	2.38	0.93	0.39	886	2.31	0.90	0.39	905	2.24	0.88	0.39	924
26	18	2.16	1.70	0.79	755	1.98	1.56	0.79	801	1.90	1.50	0.79	816	1.83	1.44	0.79	832
26	20	2.27	1.52	0.67	785	2.11	1.42	0.67	824	2.04	1.36	0.67	847	1.96	1.31	0.67	870
26	22	2.40	1.32	0.55	816	2.24	1.23	0.55	862	2.17	1.19	0.55	878	2.09	1.15	0.55	893
26	24	2.53	1.09	0.43	847	2.38	1.02	0.43	886	2.31	0.99	0.43	905	2.24	0.96	0.43	924
26	26	2.66	0.83	0.31	878	2.51	0.78	0.31	916	2.43	0.75	0.31	936	2.35	0.73	0.31	955
27	18	2.16	1.79	0.83	755	1.98	1.64	0.83	801	1.90	1.58	0.83	816	1.83	1.52	0.83	832
27	20	2.27	1.61	0.71	785	2.11	1.50	0.71	824	2.04	1.44	0.71	847	1.96	1.39	0.71	870
27	22	2.40	1.41	0.59	816	2.24	1.32	0.59	862	2.17	1.28	0.59	878	2.09	1.23	0.59	893
27	24	2.53	1.19	0.47	847	2.38	1.12	0.47	886	2.31	1.09	0.47	905	2.24	1.05	0.47	924
27	26	2.66	0.93	0.35	878	2.51	0.88	0.35	916	2.43	0.85	0.35	936	2.35	0.82	0.35	955
28	18	2.16	1.88	0.87	755	1.98	1.72	0.87	801	1.90	1.66	0.87	816	1.83	1.59	0.87	832
28	20	2.27	1.70	0.75	785	2.11	1.58	0.75	824	2.04	1.53	0.75	847	1.96	1.47	0.75	870
28	22	2.40	1.51	0.63	816	2.24	1.41	0.63	862	2.17	1.37	0.63	878	2.09	1.32	0.63	893
28	24	2.53	1.29	0.51	847	2.38	1.21	0.51	886	2.31	1.18	0.51	905	2.24	1.14	0.51	924
28	26	2.66	1.04	0.39	878	2.51	0.98	0.39	916	2.43	0.95	0.39	936	2.35	0.92	0.39	955
29	18	2.16	1.96	0.91	755	1.98	1.80	0.91	801	1.90	1.73	0.91	816	1.83	1.66	0.91	832
29	20	2.27	1.79	0.79	785	2.11	1.67	0.79	824	2.04	1.61	0.79	847	1.96	1.55	0.79	870
29	22	2.40	1.61	0.67	816	2.24	1.50	0.67	862	2.17	1.45	0.67	878	2.09	1.40	0.67	893
29	24	2.53	1.39	0.55	847	2.38	1.31	0.55	886	2.31	1.27	0.55	905	2.24	1.23	0.55	924
29	26	2.66	1.14	0.43	878	2.51	1.08	0.43	916	2.43	1.05	0.43	936	2.35	1.01	0.43	955
30	18	2.16	2.05	0.95	755	1.98	1.88	0.95	801	1.90	1.81	0.95	816	1.83	1.73	0.95	832
30	20	2.27	1.88	0.83	785	2.11	1.75	0.83	824	2.04	1.69	0.83	847	1.96	1.63	0.83	870
30	22	2.40	1.70	0.71	816	2.24	1.59	0.71	862	2.17	1.54	0.71	878	2.09	1.48	0.71	893
30	24	2.53	1.49	0.59	847	2.38	1.40	0.59	886	2.31	1.36	0.59	905	2.24	1.32	0.59	924
30	26	2.66	1.25	0.47	878	2.51	1.18	0.47	916	2.43	1.14	0.47	936	2.35	1.11	0.47	955
31	18	2.16	2.13	0.99	755	1.98	1.96	0.99	801	1.90	1.88	0.99	816	1.83	1.81	0.99	832
31	20	2.27	1.97	0.87	785	2.11	1.84	0.87	824	2.04	1.77	0.87	847	1.96	1.70	0.87	870
31	22	2.40	1.80	0.75	816	2.24	1.68	0.75	862	2.17	1.63	0.75	878	2.09	1.57	0.75	893
31	24	2.53	1.59	0.63	847	2.38	1.50	0.63	886	2.31	1.46	0.63	905	2.24	1.41	0.63	924
31	26	2.66	1.36	0.51	878	2.51	1.28	0.51	916	2.43	1.24	0.51	936	2.35	1.20	0.51	955
32	18	2.16	2.22	1.03	755	1.98	2.04	1.03	801	1.90	1.96	1.03	816	1.83	1.88	1.03	832
32	20	2.27	2.06	0.91	785	2.11	1.92	0.91	824	2.04	1.85	0.91	847	1.96	1.78	0.91	870
32	22	2.40	1.89	0.79	816	2.24	1.77	0.79	862	2.17	1.71	0.79	878	2.09	1.65	0.79	893
32	24	2.53	1.70	0.67	847	2.38	1.59	0.67	886	2.31	1.55	0.67	905	2.24	1.50	0.67	924
32	26	2.66	1.46	0.55	878	2.51	1.38	0.55	916	2.43	1.34	0.55	936	2.35	1.29	0.55	955

**NOTE:** Q: Total capacity (kW) SHF: Sensible heat factor DB: Dry-bulb temperature  
 SHC: Sensible heat capacity (kW) INPUT: Total power input (W) WB: Wet-bulb temperature

WALL-MOUNTED PERFORMANCE DATA

**COOL operation (230V)**  
**MSC-C09TV, MUH-C09TV**

CAPACITY : 2.55 kW INPUT : 910 W SHF : 0.72

		OUTDOOR DB (°C)															
INDOOR DB (°C)	INDOOR WB (°C)	21				25				27				30			
		Q	SHC	SHF	INPUT	Q	SHC	SHF	INPUT	Q	SHC	SHF	INPUT	Q	SHC	SHF	INPUT
21	18	3.00	1.62	0.54	728	2.87	1.55	0.54	764	2.75	1.49	0.54	801	2.65	1.43	0.54	837
21	20	3.12	1.31	0.42	764	3.00	1.26	0.42	810	2.91	1.22	0.42	828	2.81	1.18	0.42	865
22	18	3.00	1.74	0.58	728	2.87	1.66	0.58	764	2.75	1.60	0.58	801	2.65	1.54	0.58	837
22	20	3.12	1.44	0.46	764	3.00	1.38	0.46	810	2.91	1.34	0.46	828	2.81	1.29	0.46	865
22	22	3.25	1.11	0.34	792	3.14	1.07	0.34	842	3.06	1.04	0.34	865	2.93	1.00	0.34	901
23	18	3.00	1.86	0.62	728	2.87	1.78	0.62	764	2.75	1.71	0.62	801	2.65	1.64	0.62	837
23	20	3.12	1.56	0.50	764	3.00	1.50	0.50	810	2.91	1.45	0.50	828	2.81	1.40	0.50	865
23	22	3.25	1.24	0.38	792	3.14	1.19	0.38	842	3.06	1.16	0.38	865	2.93	1.11	0.38	901
24	18	3.00	1.98	0.66	728	2.87	1.89	0.66	764	2.75	1.82	0.66	801	2.65	1.75	0.66	837
24	20	3.12	1.69	0.54	764	3.00	1.62	0.54	810	2.91	1.57	0.54	828	2.81	1.51	0.54	865
24	22	3.25	1.37	0.42	792	3.14	1.32	0.42	842	3.06	1.29	0.42	865	2.93	1.23	0.42	901
24	24	3.42	1.03	0.30	828	3.29	0.99	0.30	874	3.21	0.96	0.30	901	3.11	0.93	0.30	946
25	18	3.00	2.10	0.70	728	2.87	2.01	0.70	764	2.75	1.93	0.70	801	2.65	1.86	0.70	837
25	20	3.12	1.81	0.58	764	3.00	1.74	0.58	810	2.91	1.69	0.58	828	2.81	1.63	0.58	865
25	22	3.25	1.50	0.46	792	3.14	1.44	0.46	842	3.06	1.41	0.46	865	2.93	1.35	0.46	901
25	24	3.42	1.16	0.34	828	3.29	1.12	0.34	874	3.21	1.09	0.34	901	3.11	1.06	0.34	946
26	18	3.00	2.22	0.74	728	2.87	2.12	0.74	764	2.75	2.04	0.74	801	2.65	1.96	0.74	837
26	20	3.12	1.94	0.62	764	3.00	1.86	0.62	810	2.91	1.80	0.62	828	2.81	1.74	0.62	865
26	22	3.25	1.63	0.50	792	3.14	1.57	0.50	842	3.06	1.53	0.50	865	2.93	1.47	0.50	901
26	24	3.42	1.30	0.38	828	3.29	1.25	0.38	874	3.21	1.22	0.38	901	3.11	1.18	0.38	946
26	26	3.52	0.91	0.26	874	3.42	0.89	0.26	919	3.37	0.88	0.26	946	3.26	0.85	0.26	974
27	18	3.00	2.34	0.78	728	2.87	2.24	0.78	764	2.75	2.15	0.78	801	2.65	2.07	0.78	837
27	20	3.12	2.06	0.66	764	3.00	1.98	0.66	810	2.91	1.92	0.66	828	2.81	1.85	0.66	865
27	22	3.25	1.76	0.54	792	3.14	1.69	0.54	842	3.06	1.65	0.54	865	2.93	1.58	0.54	901
27	24	3.42	1.44	0.42	828	3.29	1.38	0.42	874	3.21	1.35	0.42	901	3.11	1.31	0.42	946
27	26	3.52	1.06	0.30	874	3.42	1.03	0.30	919	3.37	1.01	0.30	946	3.26	0.98	0.30	974
28	18	3.00	2.46	0.82	728	2.87	2.35	0.82	764	2.75	2.26	0.82	801	2.65	2.17	0.82	837
28	20	3.12	2.19	0.70	764	3.00	2.10	0.70	810	2.91	2.03	0.70	828	2.81	1.96	0.70	865
28	22	3.25	1.89	0.58	792	3.14	1.82	0.58	842	3.06	1.77	0.58	865	2.93	1.70	0.58	901
28	24	3.42	1.57	0.46	828	3.29	1.51	0.46	874	3.21	1.48	0.46	901	3.11	1.43	0.46	946
28	26	3.52	1.20	0.34	874	3.42	1.16	0.34	919	3.37	1.14	0.34	946	3.26	1.11	0.34	974
29	18	3.00	2.58	0.86	728	2.87	2.47	0.86	764	2.75	2.37	0.86	801	2.65	2.28	0.86	837
29	20	3.12	2.31	0.74	764	3.00	2.22	0.74	810	2.91	2.15	0.74	828	2.81	2.08	0.74	865
29	22	3.25	2.02	0.62	792	3.14	1.94	0.62	842	3.06	1.90	0.62	865	2.93	1.82	0.62	901
29	24	3.42	1.71	0.50	828	3.29	1.64	0.50	874	3.21	1.61	0.50	901	3.11	1.56	0.50	946
29	26	3.52	1.34	0.38	874	3.42	1.30	0.38	919	3.37	1.28	0.38	946	3.26	1.24	0.38	974
30	18	3.00	2.70	0.90	728	2.87	2.58	0.90	764	2.75	2.48	0.90	801	2.65	2.39	0.90	837
30	20	3.12	2.44	0.78	764	3.00	2.34	0.78	810	2.91	2.27	0.78	828	2.81	2.19	0.78	865
30	22	3.25	2.15	0.66	792	3.14	2.07	0.66	842	3.06	2.02	0.66	865	2.93	1.94	0.66	901
30	24	3.42	1.85	0.54	828	3.29	1.78	0.54	874	3.21	1.74	0.54	901	3.11	1.68	0.54	946
30	26	3.52	1.48	0.42	874	3.42	1.44	0.42	919	3.37	1.41	0.42	946	3.26	1.37	0.42	974
31	18	3.00	2.82	0.94	728	2.87	2.70	0.94	764	2.75	2.59	0.94	801	2.65	2.49	0.94	837
31	20	3.12	2.56	0.82	764	3.00	2.46	0.82	810	2.91	2.38	0.82	828	2.81	2.30	0.82	865
31	22	3.25	2.28	0.70	792	3.14	2.20	0.70	842	3.06	2.14	0.70	865	2.93	2.05	0.70	901
31	24	3.42	1.98	0.58	828	3.29	1.91	0.58	874	3.21	1.86	0.58	901	3.11	1.80	0.58	946
31	26	3.52	1.62	0.46	874	3.42	1.57	0.46	919	3.37	1.55	0.46	946	3.26	1.50	0.46	974
32	18	3.00	2.94	0.98	728	2.87	2.81	0.98	764	2.75	2.70	0.98	801	2.65	2.60	0.98	837
32	20	3.12	2.69	0.86	764	3.00	2.58	0.86	810	2.91	2.50	0.86	828	2.81	2.41	0.86	865
32	22	3.25	2.41	0.74	792	3.14	2.32	0.74	842	3.06	2.26	0.74	865	2.93	2.17	0.74	901
32	24	3.42	2.12	0.62	828	3.29	2.04	0.62	874	3.21	1.99	0.62	901	3.11	1.93	0.62	946
32	26	3.52	1.76	0.50	874	3.42	1.71	0.50	919	3.37	1.68	0.50	946	3.26	1.63	0.50	974

**NOTE:** Q: Total capacity (kW) SHF: Sensible heat factor DB: Dry-bulb temperature  
SHC: Sensible heat capacity (kW) INPUT: Total power input (W) WB: Wet-bulb temperature

**COOL operation (230V)  
MSC-C09TV, MUH-C09TV**

CAPACITY : 2.55 kW INPUT : 910 W SHF : 0.72

INDOOR		OUTDOOR DB (°C)															
DB (°C)	WB (°C)	35				40				43				46			
		Q	SHC	SHF	INPUT	Q	SHC	SHF	INPUT	Q	SHC	SHF	INPUT	Q	SHC	SHF	INPUT
21	18	2.50	1.35	0.54	892	2.30	1.24	0.54	946	2.21	1.19	0.54	965	2.12	1.14	0.54	983
21	20	2.63	1.10	0.42	928	2.45	1.03	0.42	974	2.36	0.99	0.42	1001	2.27	0.95	0.42	1028
22	18	2.50	1.45	0.58	892	2.30	1.33	0.58	946	2.21	1.28	0.58	965	2.12	1.23	0.58	983
22	20	2.63	1.21	0.46	928	2.45	1.13	0.46	974	2.36	1.09	0.46	1001	2.27	1.04	0.46	1028
22	22	2.78	0.95	0.34	965	2.60	0.88	0.34	1019	2.51	0.85	0.34	1037	2.42	0.82	0.34	1056
23	18	2.50	1.55	0.62	892	2.30	1.42	0.62	946	2.21	1.37	0.62	965	2.12	1.31	0.62	983
23	20	2.63	1.31	0.50	928	2.45	1.22	0.50	974	2.36	1.18	0.50	1001	2.27	1.13	0.50	1028
23	22	2.78	1.06	0.38	965	2.60	0.99	0.38	1019	2.51	0.95	0.38	1037	2.42	0.92	0.38	1056
24	18	2.50	1.65	0.66	892	2.30	1.51	0.66	946	2.21	1.46	0.66	965	2.12	1.40	0.66	983
24	20	2.63	1.42	0.54	928	2.45	1.32	0.54	974	2.36	1.27	0.54	1001	2.27	1.23	0.54	1028
24	22	2.78	1.17	0.42	965	2.60	1.09	0.42	1019	2.51	1.05	0.42	1037	2.42	1.02	0.42	1056
24	24	2.93	0.88	0.30	1001	2.75	0.83	0.30	1047	2.68	0.80	0.30	1069	2.60	0.78	0.30	1092
25	18	2.50	1.75	0.70	892	2.30	1.61	0.70	946	2.21	1.54	0.70	965	2.12	1.48	0.70	983
25	20	2.63	1.52	0.58	928	2.45	1.42	0.58	974	2.36	1.37	0.58	1001	2.27	1.32	0.58	1028
25	22	2.78	1.28	0.46	965	2.60	1.20	0.46	1019	2.51	1.16	0.46	1037	2.42	1.11	0.46	1056
25	24	2.93	1.00	0.34	1001	2.75	0.94	0.34	1047	2.68	0.91	0.34	1069	2.60	0.88	0.34	1092
26	18	2.50	1.85	0.74	892	2.30	1.70	0.74	946	2.21	1.63	0.74	965	2.12	1.57	0.74	983
26	20	2.63	1.63	0.62	928	2.45	1.52	0.62	974	2.36	1.46	0.62	1001	2.27	1.41	0.62	1028
26	22	2.78	1.39	0.50	965	2.60	1.30	0.50	1019	2.51	1.26	0.50	1037	2.42	1.21	0.50	1056
26	24	2.93	1.11	0.38	1001	2.75	1.05	0.38	1047	2.68	1.02	0.38	1069	2.60	0.99	0.38	1092
26	26	3.09	0.80	0.26	1037	2.91	0.76	0.26	1083	2.82	0.73	0.26	1106	2.73	0.71	0.26	1128
27	18	2.50	1.95	0.78	892	2.30	1.79	0.78	946	2.21	1.72	0.78	965	2.12	1.65	0.78	983
27	20	2.63	1.73	0.66	928	2.45	1.62	0.66	974	2.36	1.56	0.66	1001	2.27	1.50	0.66	1028
27	22	2.78	1.50	0.54	965	2.60	1.40	0.54	1019	2.51	1.36	0.54	1037	2.42	1.31	0.54	1056
27	24	2.93	1.23	0.42	1001	2.75	1.16	0.42	1047	2.68	1.12	0.42	1069	2.60	1.09	0.42	1092
27	26	3.09	0.93	0.30	1037	2.91	0.87	0.30	1083	2.82	0.85	0.30	1106	2.73	0.82	0.30	1128
28	18	2.50	2.05	0.82	892	2.30	1.88	0.82	946	2.21	1.81	0.82	965	2.12	1.74	0.82	983
28	20	2.63	1.84	0.70	928	2.45	1.71	0.70	974	2.36	1.65	0.70	1001	2.27	1.59	0.70	1028
28	22	2.78	1.61	0.58	965	2.60	1.51	0.58	1019	2.51	1.46	0.58	1037	2.42	1.41	0.58	1056
28	24	2.93	1.35	0.46	1001	2.75	1.27	0.46	1047	2.68	1.23	0.46	1069	2.60	1.20	0.46	1092
28	26	3.09	1.05	0.34	1037	2.91	0.99	0.34	1083	2.82	0.96	0.34	1106	2.73	0.93	0.34	1128
29	18	2.50	2.15	0.86	892	2.30	1.97	0.86	946	2.21	1.90	0.86	965	2.12	1.82	0.86	983
29	20	2.63	1.94	0.74	928	2.45	1.81	0.74	974	2.36	1.75	0.74	1001	2.27	1.68	0.74	1028
29	22	2.78	1.72	0.62	965	2.60	1.61	0.62	1019	2.51	1.56	0.62	1037	2.42	1.50	0.62	1056
29	24	2.93	1.47	0.50	1001	2.75	1.38	0.50	1047	2.68	1.34	0.50	1069	2.60	1.30	0.50	1092
29	26	3.09	1.17	0.38	1037	2.91	1.10	0.38	1083	2.82	1.07	0.38	1106	2.73	1.04	0.38	1128
30	18	2.50	2.25	0.90	892	2.30	2.07	0.90	946	2.21	1.99	0.90	965	2.12	1.90	0.90	983
30	20	2.63	2.05	0.78	928	2.45	1.91	0.78	974	2.36	1.84	0.78	1001	2.27	1.77	0.78	1028
30	22	2.78	1.83	0.66	965	2.60	1.72	0.66	1019	2.51	1.66	0.66	1037	2.42	1.60	0.66	1056
30	24	2.93	1.58	0.54	1001	2.75	1.49	0.54	1047	2.68	1.45	0.54	1069	2.60	1.40	0.54	1092
30	26	3.09	1.30	0.42	1037	2.91	1.22	0.42	1083	2.82	1.18	0.42	1106	2.73	1.15	0.42	1128
31	18	2.50	2.35	0.94	892	2.30	2.16	0.94	946	2.21	2.07	0.94	965	2.12	1.99	0.94	983
31	20	2.63	2.15	0.82	928	2.45	2.01	0.82	974	2.36	1.93	0.82	1001	2.27	1.86	0.82	1028
31	22	2.78	1.95	0.70	965	2.60	1.82	0.70	1019	2.51	1.76	0.70	1037	2.42	1.70	0.70	1056
31	24	2.93	1.70	0.58	1001	2.75	1.60	0.58	1047	2.68	1.55	0.58	1069	2.60	1.51	0.58	1092
31	26	3.09	1.42	0.46	1037	2.91	1.34	0.46	1083	2.82	1.30	0.46	1106	2.73	1.26	0.46	1128
32	18	2.50	2.45	0.98	892	2.30	2.25	0.98	946	2.21	2.16	0.98	965	2.12	2.07	0.98	983
32	20	2.63	2.26	0.86	928	2.45	2.11	0.86	974	2.36	2.03	0.86	1001	2.27	1.95	0.86	1028
32	22	2.78	2.06	0.74	965	2.60	1.92	0.74	1019	2.51	1.86	0.74	1037	2.42	1.79	0.74	1056
32	24	2.93	1.82	0.62	1001	2.75	1.71	0.62	1047	2.68	1.66	0.62	1069	2.60	1.61	0.62	1092
32	26	3.09	1.54	0.50	1037	2.91	1.45	0.50	1083	2.82	1.41	0.50	1106	2.73	1.36	0.50	1128

**NOTE:** Q: Total capacity (kW) SHF: Sensible heat factor DB: Dry-bulb temperature  
SHC: Sensible heat capacity (kW) INPUT: Total power input (W) WB: Wet-bulb temperature

PERFORMANCE DATA

WALL-MOUNTED

**COOL operation (230V)**  
**MSC-C12TV, MUH-C12TV**

CAPACITY : 3.45 kW INPUT : 1280 W SHF : 0.70

		OUTDOOR DB (°C)															
INDOOR DB (°C)	INDOOR WB (°C)	21				25				27				30			
		Q	SHC	SHF	INPUT	Q	SHC	SHF	INPUT	Q	SHC	SHF	INPUT	Q	SHC	SHF	INPUT
21	18	4.05	2.11	0.52	1024	3.88	2.02	0.52	1075	3.73	1.94	0.52	1126	3.59	1.87	0.52	1178
21	20	4.23	1.69	0.40	1075	4.05	1.62	0.40	1139	3.93	1.57	0.40	1165	3.80	1.52	0.40	1216
22	18	4.05	2.27	0.56	1024	3.88	2.17	0.56	1075	3.73	2.09	0.56	1126	3.59	2.01	0.56	1178
22	20	4.23	1.86	0.44	1075	4.05	1.78	0.44	1139	3.93	1.73	0.44	1165	3.80	1.67	0.44	1216
22	22	4.40	1.41	0.32	1114	4.24	1.36	0.32	1184	4.14	1.32	0.32	1216	3.97	1.27	0.32	1267
23	18	4.05	2.43	0.60	1024	3.88	2.33	0.60	1075	3.73	2.24	0.60	1126	3.59	2.15	0.60	1178
23	20	4.23	2.03	0.48	1075	4.05	1.95	0.48	1139	3.93	1.89	0.48	1165	3.80	1.82	0.48	1216
23	22	4.40	1.58	0.36	1114	4.24	1.53	0.36	1184	4.14	1.49	0.36	1216	3.97	1.43	0.36	1267
24	18	4.05	2.59	0.64	1024	3.88	2.48	0.64	1075	3.73	2.38	0.64	1126	3.59	2.30	0.64	1178
24	20	4.23	2.20	0.52	1075	4.05	2.11	0.52	1139	3.93	2.05	0.52	1165	3.80	1.97	0.52	1216
24	22	4.40	1.76	0.40	1114	4.24	1.70	0.40	1184	4.14	1.66	0.40	1216	3.97	1.59	0.40	1267
24	24	4.62	1.29	0.28	1165	4.45	1.25	0.28	1229	4.35	1.22	0.28	1267	4.21	1.18	0.28	1331
25	18	4.05	2.76	0.68	1024	3.88	2.64	0.68	1075	3.73	2.53	0.68	1126	3.59	2.44	0.68	1178
25	20	4.23	2.37	0.56	1075	4.05	2.27	0.56	1139	3.93	2.20	0.56	1165	3.80	2.13	0.56	1216
25	22	4.40	1.94	0.44	1114	4.24	1.87	0.44	1184	4.14	1.82	0.44	1216	3.97	1.75	0.44	1267
25	24	4.62	1.48	0.32	1165	4.45	1.42	0.32	1229	4.35	1.39	0.32	1267	4.21	1.35	0.32	1331
26	18	4.05	2.92	0.72	1024	3.88	2.79	0.72	1075	3.73	2.68	0.72	1126	3.59	2.58	0.72	1178
26	20	4.23	2.54	0.60	1075	4.05	2.43	0.60	1139	3.93	2.36	0.60	1165	3.80	2.28	0.60	1216
26	22	4.40	2.11	0.48	1114	4.24	2.04	0.48	1184	4.14	1.99	0.48	1216	3.97	1.90	0.48	1267
26	24	4.62	1.66	0.36	1165	4.45	1.60	0.36	1229	4.35	1.56	0.36	1267	4.21	1.52	0.36	1331
26	26	4.76	1.14	0.24	1229	4.62	1.11	0.24	1293	4.55	1.09	0.24	1331	4.42	1.06	0.24	1370
27	18	4.05	3.08	0.76	1024	3.88	2.95	0.76	1075	3.73	2.83	0.76	1126	3.59	2.73	0.76	1178
27	20	4.23	2.70	0.64	1075	4.05	2.59	0.64	1139	3.93	2.52	0.64	1165	3.80	2.43	0.64	1216
27	22	4.40	2.29	0.52	1114	4.24	2.21	0.52	1184	4.14	2.15	0.52	1216	3.97	2.06	0.52	1267
27	24	4.62	1.85	0.40	1165	4.45	1.78	0.40	1229	4.35	1.74	0.40	1267	4.21	1.68	0.40	1331
27	26	4.76	1.33	0.28	1229	4.62	1.29	0.28	1293	4.55	1.28	0.28	1331	4.42	1.24	0.28	1370
28	18	4.05	3.24	0.80	1024	3.88	3.11	0.80	1075	3.73	2.98	0.80	1126	3.59	2.87	0.80	1178
28	20	4.23	2.87	0.68	1075	4.05	2.76	0.68	1139	3.93	2.67	0.68	1165	3.80	2.58	0.68	1216
28	22	4.40	2.46	0.56	1114	4.24	2.38	0.56	1184	4.14	2.32	0.56	1216	3.97	2.22	0.56	1267
28	24	4.62	2.03	0.44	1165	4.45	1.96	0.44	1229	4.35	1.91	0.44	1267	4.21	1.85	0.44	1331
28	26	4.76	1.52	0.32	1229	4.62	1.48	0.32	1293	4.55	1.46	0.32	1331	4.42	1.41	0.32	1370
29	18	4.05	3.41	0.84	1024	3.88	3.26	0.84	1075	3.73	3.13	0.84	1126	3.59	3.01	0.84	1178
29	20	4.23	3.04	0.72	1075	4.05	2.92	0.72	1139	3.93	2.83	0.72	1165	3.80	2.73	0.72	1216
29	22	4.40	2.64	0.60	1114	4.24	2.55	0.60	1184	4.14	2.48	0.60	1216	3.97	2.38	0.60	1267
29	24	4.62	2.22	0.48	1165	4.45	2.14	0.48	1229	4.35	2.09	0.48	1267	4.21	2.02	0.48	1331
29	26	4.76	1.71	0.36	1229	4.62	1.66	0.36	1293	4.55	1.64	0.36	1331	4.42	1.59	0.36	1370
30	18	4.05	3.57	0.88	1024	3.88	3.42	0.88	1075	3.73	3.28	0.88	1126	3.59	3.16	0.88	1178
30	20	4.23	3.21	0.76	1075	4.05	3.08	0.76	1139	3.93	2.99	0.76	1165	3.80	2.88	0.76	1216
30	22	4.40	2.82	0.64	1114	4.24	2.72	0.64	1184	4.14	2.65	0.64	1216	3.97	2.54	0.64	1267
30	24	4.62	2.40	0.52	1165	4.45	2.31	0.52	1229	4.35	2.26	0.52	1267	4.21	2.19	0.52	1331
30	26	4.76	1.90	0.40	1229	4.62	1.85	0.40	1293	4.55	1.82	0.40	1331	4.42	1.77	0.40	1370
31	18	4.05	3.73	0.92	1024	3.88	3.57	0.92	1075	3.73	3.43	0.92	1126	3.59	3.30	0.92	1178
31	20	4.23	3.38	0.80	1075	4.05	3.24	0.80	1139	3.93	3.15	0.80	1165	3.80	3.04	0.80	1216
31	22	4.40	2.99	0.68	1114	4.24	2.89	0.68	1184	4.14	2.82	0.68	1216	3.97	2.70	0.68	1267
31	24	4.62	2.59	0.56	1165	4.45	2.49	0.56	1229	4.35	2.43	0.56	1267	4.21	2.36	0.56	1331
31	26	4.76	2.09	0.44	1229	4.62	2.03	0.44	1293	4.55	2.00	0.44	1331	4.42	1.94	0.44	1370
32	18	4.05	3.89	0.96	1024	3.88	3.73	0.96	1075	3.73	3.58	0.96	1126	3.59	3.44	0.96	1178
32	20	4.23	3.55	0.84	1075	4.05	3.41	0.84	1139	3.93	3.30	0.84	1165	3.80	3.19	0.84	1216
32	22	4.40	3.17	0.72	1114	4.24	3.06	0.72	1184	4.14	2.98	0.72	1216	3.97	2.86	0.72	1267
32	24	4.62	2.77	0.60	1165	4.45	2.67	0.60	1229	4.35	2.61	0.60	1267	4.21	2.53	0.60	1331
32	26	4.76	2.29	0.48	1229	4.62	2.22	0.48	1293	4.55	2.19	0.48	1331	4.42	2.12	0.48	1370

**NOTE:** Q: Total capacity (kW) SHF: Sensible heat factor DB: Dry-bulb temperature  
SHC: Sensible heat capacity (kW) INPUT: Total power input (W) WB: Wet-bulb temperature



**COOL operation (230V)  
MSC-C12TV, MUH-C12TV**

CAPACITY : 3.45 kW INPUT : 1280 W SHF : 0.70

		OUTDOOR DB (°C)															
INDOOR DB (°C)	INDOOR WB (°C)	35				40				43				46			
		Q	SHC	SHF	INPUT	Q	SHC	SHF	INPUT	Q	SHC	SHF	INPUT	Q	SHC	SHF	INPUT
21	18	3.38	1.76	0.52	1254	3.11	1.61	0.52	1331	2.98	1.55	0.52	1357	2.86	1.49	0.52	1382
21	20	3.55	1.42	0.40	1306	3.31	1.32	0.40	1370	3.19	1.28	0.40	1408	3.07	1.23	0.40	1446
22	18	3.38	1.89	0.56	1254	3.11	1.74	0.56	1331	2.98	1.67	0.56	1357	2.86	1.60	0.56	1382
22	20	3.55	1.56	0.44	1306	3.31	1.46	0.44	1370	3.19	1.40	0.44	1408	3.07	1.35	0.44	1446
22	22	3.76	1.20	0.32	1357	3.52	1.13	0.32	1434	3.40	1.09	0.32	1459	3.28	1.05	0.32	1485
23	18	3.38	2.03	0.60	1254	3.11	1.86	0.60	1331	2.98	1.79	0.60	1357	2.86	1.72	0.60	1382
23	20	3.55	1.71	0.48	1306	3.31	1.59	0.48	1370	3.19	1.53	0.48	1408	3.07	1.47	0.48	1446
23	22	3.76	1.35	0.36	1357	3.52	1.27	0.36	1434	3.40	1.22	0.36	1459	3.28	1.18	0.36	1485
24	18	3.38	2.16	0.64	1254	3.11	1.99	0.64	1331	2.98	1.91	0.64	1357	2.86	1.83	0.64	1382
24	20	3.55	1.85	0.52	1306	3.31	1.72	0.52	1370	3.19	1.66	0.52	1408	3.07	1.60	0.52	1446
24	22	3.76	1.50	0.40	1357	3.52	1.41	0.40	1434	3.40	1.36	0.40	1459	3.28	1.31	0.40	1485
24	24	3.97	1.11	0.28	1408	3.73	1.04	0.28	1472	3.62	1.01	0.28	1504	3.52	0.99	0.28	1536
25	18	3.38	2.30	0.68	1254	3.11	2.11	0.68	1331	2.98	2.03	0.68	1357	2.86	1.95	0.68	1382
25	20	3.55	1.99	0.56	1306	3.31	1.85	0.56	1370	3.19	1.79	0.56	1408	3.07	1.72	0.56	1446
25	22	3.76	1.65	0.44	1357	3.52	1.55	0.44	1434	3.40	1.50	0.44	1459	3.28	1.44	0.44	1485
25	24	3.97	1.27	0.32	1408	3.73	1.19	0.32	1472	3.62	1.16	0.32	1504	3.52	1.13	0.32	1536
26	18	3.38	2.43	0.72	1254	3.11	2.24	0.72	1331	2.98	2.15	0.72	1357	2.86	2.06	0.72	1382
26	20	3.55	2.13	0.60	1306	3.31	1.99	0.60	1370	3.19	1.91	0.60	1408	3.07	1.84	0.60	1446
26	22	3.76	1.81	0.48	1357	3.52	1.69	0.48	1434	3.40	1.63	0.48	1459	3.28	1.57	0.48	1485
26	24	3.97	1.43	0.36	1408	3.73	1.34	0.36	1472	3.62	1.30	0.36	1504	3.52	1.27	0.36	1536
26	26	4.17	1.00	0.24	1459	3.93	0.94	0.24	1523	3.81	0.91	0.24	1555	3.69	0.89	0.24	1587
27	18	3.38	2.57	0.76	1254	3.11	2.36	0.76	1331	2.98	2.27	0.76	1357	2.86	2.18	0.76	1382
27	20	3.55	2.27	0.64	1306	3.31	2.12	0.64	1370	3.19	2.04	0.64	1408	3.07	1.97	0.64	1446
27	22	3.76	1.96	0.52	1357	3.52	1.83	0.52	1434	3.40	1.77	0.52	1459	3.28	1.70	0.52	1485
27	24	3.97	1.59	0.40	1408	3.73	1.49	0.40	1472	3.62	1.45	0.40	1504	3.52	1.41	0.40	1536
27	26	4.17	1.17	0.28	1459	3.93	1.10	0.28	1523	3.81	1.07	0.28	1555	3.69	1.03	0.28	1587
28	18	3.38	2.70	0.80	1254	3.11	2.48	0.80	1331	2.98	2.39	0.80	1357	2.86	2.29	0.80	1382
28	20	3.55	2.42	0.68	1306	3.31	2.25	0.68	1370	3.19	2.17	0.68	1408	3.07	2.09	0.68	1446
28	22	3.76	2.11	0.56	1357	3.52	1.97	0.56	1434	3.40	1.90	0.56	1459	3.28	1.84	0.56	1485
28	24	3.97	1.75	0.44	1408	3.73	1.64	0.44	1472	3.62	1.59	0.44	1504	3.52	1.55	0.44	1536
28	26	4.17	1.34	0.32	1459	3.93	1.26	0.32	1523	3.81	1.22	0.32	1555	3.69	1.18	0.32	1587
29	18	3.38	2.84	0.84	1254	3.11	2.61	0.84	1331	2.98	2.51	0.84	1357	2.86	2.41	0.84	1382
29	20	3.55	2.56	0.72	1306	3.31	2.38	0.72	1370	3.19	2.30	0.72	1408	3.07	2.21	0.72	1446
29	22	3.76	2.26	0.60	1357	3.52	2.11	0.60	1434	3.40	2.04	0.60	1459	3.28	1.97	0.60	1485
29	24	3.97	1.90	0.48	1408	3.73	1.79	0.48	1472	3.62	1.74	0.48	1504	3.52	1.69	0.48	1536
29	26	4.17	1.50	0.36	1459	3.93	1.42	0.36	1523	3.81	1.37	0.36	1555	3.69	1.33	0.36	1587
30	18	3.38	2.98	0.88	1254	3.11	2.73	0.88	1331	2.98	2.63	0.88	1357	2.86	2.52	0.88	1382
30	20	3.55	2.70	0.76	1306	3.31	2.52	0.76	1370	3.19	2.43	0.76	1408	3.07	2.33	0.76	1446
30	22	3.76	2.41	0.64	1357	3.52	2.25	0.64	1434	3.40	2.17	0.64	1459	3.28	2.10	0.64	1485
30	24	3.97	2.06	0.52	1408	3.73	1.94	0.52	1472	3.62	1.88	0.52	1504	3.52	1.83	0.52	1536
30	26	4.17	1.67	0.40	1459	3.93	1.57	0.40	1523	3.81	1.52	0.40	1555	3.69	1.48	0.40	1587
31	18	3.38	3.11	0.92	1254	3.11	2.86	0.92	1331	2.98	2.75	0.92	1357	2.86	2.63	0.92	1382
31	20	3.55	2.84	0.80	1306	3.31	2.65	0.80	1370	3.19	2.55	0.80	1408	3.07	2.46	0.80	1446
31	22	3.76	2.56	0.68	1357	3.52	2.39	0.68	1434	3.40	2.31	0.68	1459	3.28	2.23	0.68	1485
31	24	3.97	2.22	0.56	1408	3.73	2.09	0.56	1472	3.62	2.03	0.56	1504	3.52	1.97	0.56	1536
31	26	4.17	1.84	0.44	1459	3.93	1.73	0.44	1523	3.81	1.68	0.44	1555	3.69	1.62	0.44	1587
32	18	3.38	3.25	0.96	1254	3.11	2.98	0.96	1331	2.98	2.86	0.96	1357	2.86	2.75	0.96	1382
32	20	3.55	2.98	0.84	1306	3.31	2.78	0.84	1370	3.19	2.68	0.84	1408	3.07	2.58	0.84	1446
32	22	3.76	2.71	0.72	1357	3.52	2.53	0.72	1434	3.40	2.45	0.72	1459	3.28	2.36	0.72	1485
32	24	3.97	2.38	0.60	1408	3.73	2.24	0.60	1472	3.62	2.17	0.60	1504	3.52	2.11	0.60	1536
32	26	4.17	2.00	0.48	1459	3.93	1.89	0.48	1523	3.81	1.83	0.48	1555	3.69	1.77	0.48	1587

**NOTE:** Q: Total capacity (kW) SHF: Sensible heat factor DB: Dry-bulb temperature  
SHC: Sensible heat capacity (kW) INPUT: Total power input (W) WB: Wet-bulb temperature

WALL-MOUNTED PERFORMANCE DATA

**COOL operation (230V)**  
**MSH-C18TV, MUH-C18TV**

CAPACITY : 5.2 kW INPUT : 2110 W SHF : 0.68

		OUTDOOR DB (°C)															
INDOOR DB (°C)	INDOOR WB (°C)	21				25				27				30			
		Q	SHC	SHF	INPUT	Q	SHC	SHF	INPUT	Q	SHC	SHF	INPUT	Q	SHC	SHF	INPUT
21	18	6.11	3.06	0.50	1688	5.85	2.93	0.50	1772	5.62	2.81	0.50	1857	5.41	2.70	0.50	1941
21	20	6.37	2.42	0.38	1772	6.11	2.32	0.38	1878	5.93	2.25	0.38	1920	5.72	2.17	0.38	2005
22	18	6.11	3.30	0.54	1688	5.85	3.16	0.54	1772	5.62	3.03	0.54	1857	5.41	2.92	0.54	1941
22	20	6.37	2.68	0.42	1772	6.11	2.57	0.42	1878	5.93	2.49	0.42	1920	5.72	2.40	0.42	2005
22	22	6.63	1.99	0.30	1836	6.40	1.92	0.30	1952	6.24	1.87	0.30	2005	5.98	1.79	0.30	2089
23	18	6.11	3.54	0.58	1688	5.85	3.39	0.58	1772	5.62	3.26	0.58	1857	5.41	3.14	0.58	1941
23	20	6.37	2.93	0.46	1772	6.11	2.81	0.46	1878	5.93	2.73	0.46	1920	5.72	2.63	0.46	2005
23	22	6.63	2.25	0.34	1836	6.40	2.17	0.34	1952	6.24	2.12	0.34	2005	5.98	2.03	0.34	2089
24	18	6.11	3.79	0.62	1688	5.85	3.63	0.62	1772	5.62	3.48	0.62	1857	5.41	3.35	0.62	1941
24	20	6.37	3.19	0.50	1772	6.11	3.06	0.50	1878	5.93	2.96	0.50	1920	5.72	2.86	0.50	2005
24	22	6.63	2.52	0.38	1836	6.40	2.43	0.38	1952	6.24	2.37	0.38	2005	5.98	2.27	0.38	2089
24	24	6.97	1.81	0.26	1920	6.71	1.74	0.26	2026	6.55	1.70	0.26	2089	6.34	1.65	0.26	2194
25	18	6.11	4.03	0.66	1688	5.85	3.86	0.66	1772	5.62	3.71	0.66	1857	5.41	3.57	0.66	1941
25	20	6.37	3.44	0.54	1772	6.11	3.30	0.54	1878	5.93	3.20	0.54	1920	5.72	3.09	0.54	2005
25	22	6.63	2.78	0.42	1836	6.40	2.69	0.42	1952	6.24	2.62	0.42	2005	5.98	2.51	0.42	2089
25	24	6.97	2.09	0.30	1920	6.71	2.01	0.30	2026	6.55	1.97	0.30	2089	6.34	1.90	0.30	2194
26	18	6.11	4.28	0.70	1688	5.85	4.10	0.70	1772	5.62	3.93	0.70	1857	5.41	3.79	0.70	1941
26	20	6.37	3.69	0.58	1772	6.11	3.54	0.58	1878	5.93	3.44	0.58	1920	5.72	3.32	0.58	2005
26	22	6.63	3.05	0.46	1836	6.40	2.94	0.46	1952	6.24	2.87	0.46	2005	5.98	2.75	0.46	2089
26	24	6.97	2.37	0.34	1920	6.71	2.28	0.34	2026	6.55	2.23	0.34	2089	6.34	2.16	0.34	2194
26	26	7.18	1.58	0.22	2026	6.97	1.53	0.22	2131	6.86	1.51	0.22	2194	6.66	1.46	0.22	2258
27	18	6.11	4.52	0.74	1688	5.85	4.33	0.74	1772	5.62	4.16	0.74	1857	5.41	4.00	0.74	1941
27	20	6.37	3.95	0.62	1772	6.11	3.79	0.62	1878	5.93	3.68	0.62	1920	5.72	3.55	0.62	2005
27	22	6.63	3.32	0.50	1836	6.40	3.20	0.50	1952	6.24	3.12	0.50	2005	5.98	2.99	0.50	2089
27	24	6.97	2.65	0.38	1920	6.71	2.55	0.38	2026	6.55	2.49	0.38	2089	6.34	2.41	0.38	2194
27	26	7.18	1.87	0.26	2026	6.97	1.81	0.26	2131	6.86	1.78	0.26	2194	6.66	1.73	0.26	2258
28	18	6.11	4.77	0.78	1688	5.85	4.56	0.78	1772	5.62	4.38	0.78	1857	5.41	4.22	0.78	1941
28	20	6.37	4.20	0.66	1772	6.11	4.03	0.66	1878	5.93	3.91	0.66	1920	5.72	3.78	0.66	2005
28	22	6.63	3.58	0.54	1836	6.40	3.45	0.54	1952	6.24	3.37	0.54	2005	5.98	3.23	0.54	2089
28	24	6.97	2.93	0.42	1920	6.71	2.82	0.42	2026	6.55	2.75	0.42	2089	6.34	2.66	0.42	2194
28	26	7.18	2.15	0.30	2026	6.97	2.09	0.30	2131	6.86	2.06	0.30	2194	6.66	2.00	0.30	2258
29	18	6.11	5.01	0.82	1688	5.85	4.80	0.82	1772	5.62	4.61	0.82	1857	5.41	4.43	0.82	1941
29	20	6.37	4.46	0.70	1772	6.11	4.28	0.70	1878	5.93	4.15	0.70	1920	5.72	4.00	0.70	2005
29	22	6.63	3.85	0.58	1836	6.40	3.71	0.58	1952	6.24	3.62	0.58	2005	5.98	3.47	0.58	2089
29	24	6.97	3.21	0.46	1920	6.71	3.09	0.46	2026	6.55	3.01	0.46	2089	6.34	2.92	0.46	2194
29	26	7.18	2.44	0.34	2026	6.97	2.37	0.34	2131	6.86	2.33	0.34	2194	6.66	2.26	0.34	2258
30	18	6.11	5.25	0.86	1688	5.85	5.03	0.86	1772	5.62	4.83	0.86	1857	5.41	4.65	0.86	1941
30	20	6.37	4.71	0.74	1772	6.11	4.52	0.74	1878	5.93	4.39	0.74	1920	5.72	4.23	0.74	2005
30	22	6.63	4.11	0.62	1836	6.40	3.97	0.62	1952	6.24	3.87	0.62	2005	5.98	3.71	0.62	2089
30	24	6.97	3.48	0.50	1920	6.71	3.35	0.50	2026	6.55	3.28	0.50	2089	6.34	3.17	0.50	2194
30	26	7.18	2.73	0.38	2026	6.97	2.65	0.38	2131	6.86	2.61	0.38	2194	6.66	2.53	0.38	2258
31	18	6.11	5.50	0.90	1688	5.85	5.27	0.90	1772	5.62	5.05	0.90	1857	5.41	4.87	0.90	1941
31	20	6.37	4.97	0.78	1772	6.11	4.77	0.78	1878	5.93	4.62	0.78	1920	5.72	4.46	0.78	2005
31	22	6.63	4.38	0.66	1836	6.40	4.22	0.66	1952	6.24	4.12	0.66	2005	5.98	3.95	0.66	2089
31	24	6.97	3.76	0.54	1920	6.71	3.62	0.54	2026	6.55	3.54	0.54	2089	6.34	3.43	0.54	2194
31	26	7.18	3.01	0.42	2026	6.97	2.93	0.42	2131	6.86	2.88	0.42	2194	6.66	2.80	0.42	2258
32	18	6.11	5.74	0.94	1688	5.85	5.50	0.94	1772	5.62	5.28	0.94	1857	5.41	5.08	0.94	1941
32	20	6.37	5.22	0.82	1772	6.11	5.01	0.82	1878	5.93	4.86	0.82	1920	5.72	4.69	0.82	2005
32	22	6.63	4.64	0.70	1836	6.40	4.48	0.70	1952	6.24	4.37	0.70	2005	5.98	4.19	0.70	2089
32	24	6.97	4.04	0.58	1920	6.71	3.89	0.58	2026	6.55	3.80	0.58	2089	6.34	3.68	0.58	2194
32	26	7.18	3.30	0.46	2026	6.97	3.21	0.46	2131	6.86	3.16	0.46	2194	6.66	3.06	0.46	2258

**NOTE:** Q: Total capacity (kW) SHF: Sensible heat factor DB: Dry-bulb temperature  
 SHC: Sensible heat capacity (kW) INPUT: Total power input (W) WB: Wet-bulb temperature

**COOL operation (230V)  
MSH-C18TV, MUH-C18TV**

CAPACITY : 5.2 kW INPUT : 2110 W SHF : 0.68

		OUTDOOR DB (°C)															
INDOOR DB (°C)	INDOOR WB (°C)	35				40				43				46			
		Q	SHC	SHF	INPUT	Q	SHC	SHF	INPUT	Q	SHC	SHF	INPUT	Q	SHC	SHF	INPUT
21	18	5.10	2.55	0.50	2068	4.68	2.34	0.50	2194	4.50	2.25	0.50	2237	4.32	2.16	0.50	2279
21	20	5.36	2.04	0.38	2152	4.99	1.90	0.38	2258	4.81	1.83	0.38	2321	4.63	1.76	0.38	2384
22	18	5.10	2.75	0.54	2068	4.68	2.53	0.54	2194	4.50	2.43	0.54	2237	4.32	2.33	0.54	2279
22	20	5.36	2.25	0.42	2152	4.99	2.10	0.42	2258	4.81	2.02	0.42	2321	4.63	1.94	0.42	2384
22	22	5.67	1.70	0.30	2237	5.30	1.59	0.30	2363	5.12	1.54	0.30	2405	4.94	1.48	0.30	2448
23	18	5.10	2.96	0.58	2068	4.68	2.71	0.58	2194	4.50	2.61	0.58	2237	4.32	2.50	0.58	2279
23	20	5.36	2.46	0.46	2152	4.99	2.30	0.46	2258	4.81	2.21	0.46	2321	4.63	2.13	0.46	2384
23	22	5.67	1.93	0.34	2237	5.30	1.80	0.34	2363	5.12	1.74	0.34	2405	4.94	1.68	0.34	2448
24	18	5.10	3.16	0.62	2068	4.68	2.90	0.62	2194	4.50	2.79	0.62	2237	4.32	2.68	0.62	2279
24	20	5.36	2.68	0.50	2152	4.99	2.50	0.50	2258	4.81	2.41	0.50	2321	4.63	2.31	0.50	2384
24	22	5.67	2.15	0.38	2237	5.30	2.02	0.38	2363	5.12	1.95	0.38	2405	4.94	1.88	0.38	2448
24	24	5.98	1.55	0.26	2321	5.62	1.49	0.26	2427	5.46	1.42	0.26	2479	5.30	1.38	0.26	2532
25	18	5.10	3.36	0.66	2068	4.68	3.09	0.66	2194	4.50	2.97	0.66	2237	4.32	2.85	0.66	2279
25	20	5.36	2.89	0.54	2152	4.99	2.70	0.54	2258	4.81	2.60	0.54	2321	4.63	2.50	0.54	2384
25	22	5.67	2.38	0.42	2237	5.30	2.23	0.42	2363	5.12	2.15	0.42	2405	4.94	2.07	0.42	2448
25	24	5.98	1.79	0.30	2321	5.62	1.68	0.30	2427	5.46	1.64	0.30	2479	5.30	1.59	0.30	2532
26	18	5.10	3.57	0.70	2068	4.68	3.28	0.70	2194	4.50	3.15	0.70	2237	4.32	3.02	0.70	2279
26	20	5.36	3.11	0.58	2152	4.99	2.90	0.58	2258	4.81	2.79	0.58	2321	4.63	2.68	0.58	2384
26	22	5.67	2.61	0.46	2237	5.30	2.44	0.46	2363	5.12	2.36	0.46	2405	4.94	2.27	0.46	2448
26	24	5.98	2.03	0.34	2321	5.62	1.91	0.34	2427	5.46	1.86	0.34	2479	5.30	1.80	0.34	2532
26	26	6.29	1.38	0.22	2405	5.93	1.30	0.22	2511	5.75	1.26	0.22	2564	5.56	1.22	0.22	2616
27	18	5.10	3.77	0.74	2068	4.68	3.46	0.74	2194	4.50	3.33	0.74	2237	4.32	3.19	0.74	2279
27	20	5.36	3.32	0.62	2152	4.99	3.10	0.62	2258	4.81	2.98	0.62	2321	4.63	2.87	0.62	2384
27	22	5.67	2.83	0.50	2237	5.30	2.65	0.50	2363	5.12	2.56	0.50	2405	4.94	2.47	0.50	2448
27	24	5.98	2.27	0.38	2321	5.62	2.13	0.38	2427	5.46	2.07	0.38	2479	5.30	2.02	0.38	2532
27	26	6.29	1.64	0.26	2405	5.93	1.54	0.26	2511	5.75	1.49	0.26	2564	5.56	1.45	0.26	2616
28	18	5.10	3.97	0.78	2068	4.68	3.65	0.78	2194	4.50	3.51	0.78	2237	4.32	3.37	0.78	2279
28	20	5.36	3.53	0.66	2152	4.99	3.29	0.66	2258	4.81	3.17	0.66	2321	4.63	3.05	0.66	2384
28	22	5.67	3.06	0.54	2237	5.30	2.86	0.54	2363	5.12	2.77	0.54	2405	4.94	2.67	0.54	2448
28	24	5.98	2.51	0.42	2321	5.62	2.36	0.42	2427	5.46	2.29	0.42	2479	5.30	2.23	0.42	2532
28	26	6.29	1.89	0.30	2405	5.93	1.78	0.30	2511	5.75	1.72	0.30	2564	5.56	1.67	0.30	2616
29	18	5.10	4.18	0.82	2068	4.68	3.84	0.82	2194	4.50	3.69	0.82	2237	4.32	3.54	0.82	2279
29	20	5.36	3.75	0.70	2152	4.99	3.49	0.70	2258	4.81	3.37	0.70	2321	4.63	3.24	0.70	2384
29	22	5.67	3.29	0.58	2237	5.30	3.08	0.58	2363	5.12	2.97	0.58	2405	4.94	2.87	0.58	2448
29	24	5.98	2.75	0.46	2321	5.62	2.58	0.46	2427	5.46	2.51	0.46	2479	5.30	2.44	0.46	2532
29	26	6.29	2.14	0.34	2405	5.93	2.02	0.34	2511	5.75	1.95	0.34	2564	5.56	1.89	0.34	2616
30	18	5.10	4.38	0.86	2068	4.68	4.02	0.86	2194	4.50	3.87	0.86	2237	4.32	3.71	0.86	2279
30	20	5.36	3.96	0.74	2152	4.99	3.69	0.74	2258	4.81	3.56	0.74	2321	4.63	3.42	0.74	2384
30	22	5.67	3.51	0.62	2237	5.30	3.29	0.62	2363	5.12	3.18	0.62	2405	4.94	3.06	0.62	2448
30	24	5.98	2.99	0.50	2321	5.62	2.81	0.50	2427	5.46	2.73	0.50	2479	5.30	2.65	0.50	2532
30	26	6.29	2.39	0.38	2405	5.93	2.25	0.38	2511	5.75	2.18	0.38	2564	5.56	2.11	0.38	2616
31	18	5.10	4.59	0.90	2068	4.68	4.21	0.90	2194	4.50	4.05	0.90	2237	4.32	3.88	0.90	2279
31	20	5.36	4.18	0.78	2152	4.99	3.89	0.78	2258	4.81	3.75	0.78	2321	4.63	3.61	0.78	2384
31	22	5.67	3.74	0.66	2237	5.30	3.50	0.66	2363	5.12	3.38	0.66	2405	4.94	3.26	0.66	2448
31	24	5.98	3.23	0.54	2321	5.62	3.03	0.54	2427	5.46	2.95	0.54	2479	5.30	2.86	0.54	2532
31	26	6.29	2.64	0.42	2405	5.93	2.49	0.42	2511	5.75	2.41	0.42	2564	5.56	2.34	0.42	2616
32	18	5.10	4.79	0.94	2068	4.68	4.40	0.94	2194	4.50	4.23	0.94	2237	4.32	4.06	0.94	2279
32	20	5.36	4.39	0.82	2152	4.99	4.09	0.82	2258	4.81	3.94	0.82	2321	4.63	3.79	0.82	2384
32	22	5.67	3.97	0.70	2237	5.30	3.71	0.70	2363	5.12	3.59	0.70	2405	4.94	3.46	0.70	2448
32	24	5.98	3.47	0.58	2321	5.62	3.26	0.58	2427	5.46	3.17	0.58	2479	5.30	3.08	0.58	2532
32	26	6.29	2.89	0.46	2405	5.93	2.73	0.46	2511	5.75	2.64	0.46	2564	5.56	2.56	0.46	2616

**NOTE:** Q: Total capacity (kW) SHF: Sensible heat factor DB: Dry-bulb temperature  
SHC: Sensible heat capacity (kW) INPUT: Total power input (W) WB: Wet-bulb temperature

PERFORMANCE DATA

WALL-MOUNTED

**COOL operation (230V)**  
**MSH-C24TV, MUH-C24TV**

CAPACITY : 6.3 kW INPUT : 2850 W SHF : 0.67

		OUTDOOR DB (°C)															
INDOOR DB (°C)	INDOOR WB (°C)	21				25				27				30			
		Q	SHC	SHF	INPUT	Q	SHC	SHF	INPUT	Q	SHC	SHF	INPUT	Q	SHC	SHF	INPUT
21	18	7.40	3.63	0.49	2280	7.09	3.47	0.49	2394	6.80	3.33	0.49	2508	6.55	3.21	0.49	2622
21	20	7.72	2.86	0.37	2394	7.40	2.74	0.37	2537	7.18	2.66	0.37	2594	6.93	2.56	0.37	2708
22	18	7.40	3.92	0.53	2280	7.09	3.76	0.53	2394	6.80	3.61	0.53	2508	6.55	3.47	0.53	2622
22	20	7.72	3.16	0.41	2394	7.40	3.04	0.41	2537	7.18	2.94	0.41	2594	6.93	2.84	0.41	2708
22	22	8.03	2.33	0.29	2480	7.75	2.25	0.29	2636	7.56	2.19	0.29	2708	7.25	2.10	0.29	2822
23	18	7.40	4.22	0.57	2280	7.09	4.04	0.57	2394	6.80	3.88	0.57	2508	6.55	3.73	0.57	2622
23	20	7.72	3.47	0.45	2394	7.40	3.33	0.45	2537	7.18	3.23	0.45	2594	6.93	3.12	0.45	2708
23	22	8.03	2.65	0.33	2480	7.75	2.56	0.33	2636	7.56	2.49	0.33	2708	7.25	2.39	0.33	2822
24	18	7.40	4.52	0.61	2280	7.09	4.32	0.61	2394	6.80	4.15	0.61	2508	6.55	4.00	0.61	2622
24	20	7.72	3.78	0.49	2394	7.40	3.63	0.49	2537	7.18	3.52	0.49	2594	6.93	3.40	0.49	2708
24	22	8.03	2.97	0.37	2480	7.75	2.87	0.37	2636	7.56	2.80	0.37	2708	7.25	2.68	0.37	2822
24	24	8.44	2.11	0.25	2594	8.13	2.03	0.25	2736	7.94	1.98	0.25	2822	7.69	1.92	0.25	2964
25	18	7.40	4.81	0.65	2280	7.09	4.61	0.65	2394	6.80	4.42	0.65	2508	6.55	4.26	0.65	2622
25	20	7.72	4.09	0.53	2394	7.40	3.92	0.53	2537	7.18	3.81	0.53	2594	6.93	3.67	0.53	2708
25	22	8.03	3.29	0.41	2480	7.75	3.18	0.41	2636	7.56	3.10	0.41	2708	7.25	2.97	0.41	2822
25	24	8.44	2.45	0.29	2594	8.13	2.36	0.29	2736	7.94	2.30	0.29	2822	7.69	2.23	0.29	2964
26	18	7.40	5.11	0.69	2280	7.09	4.89	0.69	2394	6.80	4.69	0.69	2508	6.55	4.52	0.69	2622
26	20	7.72	4.40	0.57	2394	7.40	4.22	0.57	2537	7.18	4.09	0.57	2594	6.93	3.95	0.57	2708
26	22	8.03	3.61	0.45	2480	7.75	3.49	0.45	2636	7.56	3.40	0.45	2708	7.25	3.26	0.45	2822
26	24	8.44	2.79	0.33	2594	8.13	2.68	0.33	2736	7.94	2.62	0.33	2822	7.69	2.54	0.33	2964
26	26	8.69	1.83	0.21	2736	8.44	1.77	0.21	2879	8.32	1.75	0.21	2964	8.06	1.69	0.21	3050
27	18	7.40	5.40	0.73	2280	7.09	5.17	0.73	2394	6.80	4.97	0.73	2508	6.55	4.78	0.73	2622
27	20	7.72	4.71	0.61	2394	7.40	4.52	0.61	2537	7.18	4.38	0.61	2594	6.93	4.23	0.61	2708
27	22	8.03	3.94	0.49	2480	7.75	3.80	0.49	2636	7.56	3.70	0.49	2708	7.25	3.55	0.49	2822
27	24	8.44	3.12	0.37	2594	8.13	3.01	0.37	2736	7.94	2.94	0.37	2822	7.69	2.84	0.37	2964
27	26	8.69	2.17	0.25	2736	8.44	2.11	0.25	2879	8.32	2.08	0.25	2964	8.06	2.02	0.25	3050
28	18	7.40	5.70	0.77	2280	7.09	5.46	0.77	2394	6.80	5.24	0.77	2508	6.55	5.05	0.77	2622
28	20	7.72	5.02	0.65	2394	7.40	4.81	0.65	2537	7.18	4.67	0.65	2594	6.93	4.50	0.65	2708
28	22	8.03	4.26	0.53	2480	7.75	4.11	0.53	2636	7.56	4.01	0.53	2708	7.25	3.84	0.53	2822
28	24	8.44	3.46	0.41	2594	8.13	3.33	0.41	2736	7.94	3.25	0.41	2822	7.69	3.15	0.41	2964
28	26	8.69	2.52	0.29	2736	8.44	2.45	0.29	2879	8.32	2.41	0.29	2964	8.06	2.34	0.29	3050
29	18	7.40	6.00	0.81	2280	7.09	5.74	0.81	2394	6.80	5.51	0.81	2508	6.55	5.31	0.81	2622
29	20	7.72	5.33	0.69	2394	7.40	5.11	0.69	2537	7.18	4.96	0.69	2594	6.93	4.78	0.69	2708
29	22	8.03	4.58	0.57	2480	7.75	4.42	0.57	2636	7.56	4.31	0.57	2708	7.25	4.13	0.57	2822
29	24	8.44	3.80	0.45	2594	8.13	3.66	0.45	2736	7.94	3.57	0.45	2822	7.69	3.46	0.45	2964
29	26	8.69	2.87	0.33	2736	8.44	2.79	0.33	2879	8.32	2.74	0.33	2964	8.06	2.66	0.33	3050
30	18	7.40	6.29	0.85	2280	7.09	6.02	0.85	2394	6.80	5.78	0.85	2508	6.55	5.57	0.85	2622
30	20	7.72	5.63	0.73	2394	7.40	5.40	0.73	2537	7.18	5.24	0.73	2594	6.93	5.06	0.73	2708
30	22	8.03	4.90	0.61	2480	7.75	4.73	0.61	2636	7.56	4.61	0.61	2708	7.25	4.42	0.61	2822
30	24	8.44	4.14	0.49	2594	8.13	3.98	0.49	2736	7.94	3.89	0.49	2822	7.69	3.77	0.49	2964
30	26	8.69	3.22	0.37	2736	8.44	3.12	0.37	2879	8.32	3.08	0.37	2964	8.06	2.98	0.37	3050
31	18	7.40	6.59	0.89	2280	7.09	6.31	0.89	2394	6.80	6.06	0.89	2508	6.55	5.83	0.89	2622
31	20	7.72	5.94	0.77	2394	7.40	5.70	0.77	2537	7.18	5.53	0.77	2594	6.93	5.34	0.77	2708
31	22	8.03	5.22	0.65	2480	7.75	5.04	0.65	2636	7.56	4.91	0.65	2708	7.25	4.71	0.65	2822
31	24	8.44	4.47	0.53	2594	8.13	4.31	0.53	2736	7.94	4.21	0.53	2822	7.69	4.07	0.53	2964
31	26	8.69	3.56	0.41	2736	8.44	3.46	0.41	2879	8.32	3.41	0.41	2964	8.06	3.31	0.41	3050
32	18	7.40	6.88	0.93	2280	7.09	6.59	0.93	2394	6.80	6.33	0.93	2508	6.55	6.09	0.93	2622
32	20	7.72	6.25	0.81	2394	7.40	6.00	0.81	2537	7.18	5.82	0.81	2594	6.93	5.61	0.81	2708
32	22	8.03	5.54	0.69	2480	7.75	5.35	0.69	2636	7.56	5.22	0.69	2708	7.25	5.00	0.69	2822
32	24	8.44	4.81	0.57	2594	8.13	4.63	0.57	2736	7.94	4.52	0.57	2822	7.69	4.38	0.57	2964
32	26	8.69	3.91	0.45	2736	8.44	3.80	0.45	2879	8.32	3.74	0.45	2964	8.06	3.63	0.45	3050

**NOTE:** Q: Total capacity (kW) SHF: Sensible heat factor DB: Dry-bulb temperature  
SHC: Sensible heat capacity (kW) INPUT: Total power input (W) WB: Wet-bulb temperature

**COOL operation (230V)  
MSH-C24TV, MUH-C24TV**

CAPACITY : 6.3 kW INPUT : 2850 W SHF : 0.67

		OUTDOOR DB (°C)															
INDOOR DB (°C)	INDOOR WB (°C)	35				40				43				46			
		Q	SHC	SHF	INPUT	Q	SHC	SHF	INPUT	Q	SHC	SHF	INPUT	Q	SHC	SHF	INPUT
21	18	6.17	3.03	0.49	2793	5.67	2.78	0.49	2964	5.45	2.67	0.49	3021	5.23	2.56	0.49	3078
21	20	6.49	2.40	0.37	2907	6.05	2.24	0.37	3050	5.83	2.16	0.37	3135	5.61	2.07	0.37	3221
22	18	6.17	3.27	0.53	2793	5.67	3.01	0.53	2964	5.45	2.89	0.53	3021	5.23	2.77	0.53	3078
22	20	6.49	2.66	0.41	2907	6.05	2.48	0.41	3050	5.83	2.39	0.41	3135	5.61	2.30	0.41	3221
22	22	6.87	1.99	0.29	3021	6.43	1.86	0.29	3192	6.21	1.80	0.29	3249	5.99	1.74	0.29	3306
23	18	6.17	3.52	0.57	2793	5.67	3.23	0.57	2964	5.45	3.11	0.57	3021	5.23	2.98	0.57	3078
23	20	6.49	2.92	0.45	2907	6.05	2.72	0.45	3050	5.83	2.62	0.45	3135	5.61	2.52	0.45	3221
23	22	6.87	2.27	0.33	3021	6.43	2.12	0.33	3192	6.21	2.05	0.33	3249	5.99	1.98	0.33	3306
24	18	6.17	3.77	0.61	2793	5.67	3.46	0.61	2964	5.45	3.32	0.61	3021	5.23	3.19	0.61	3078
24	20	6.49	3.18	0.49	2907	6.05	2.96	0.49	3050	5.83	2.86	0.49	3135	5.61	2.75	0.49	3221
24	22	6.87	2.54	0.37	3021	6.43	2.38	0.37	3192	6.21	2.30	0.37	3249	5.99	2.21	0.37	3306
24	24	7.25	1.81	0.25	3135	6.80	1.70	0.25	3278	6.62	1.65	0.25	3349	6.43	1.61	0.25	3420
25	18	6.17	4.01	0.65	2793	5.67	3.69	0.65	2964	5.45	3.54	0.65	3021	5.23	3.40	0.65	3078
25	20	6.49	3.44	0.53	2907	6.05	3.21	0.53	3050	5.83	3.09	0.53	3135	5.61	2.97	0.53	3221
25	22	6.87	2.82	0.41	3021	6.43	2.63	0.41	3192	6.21	2.54	0.41	3249	5.99	2.45	0.41	3306
25	24	7.25	2.10	0.29	3135	6.80	1.97	0.29	3278	6.62	1.92	0.29	3349	6.43	1.86	0.29	3420
26	18	6.17	4.26	0.69	2793	5.67	3.91	0.69	2964	5.45	3.76	0.69	3021	5.23	3.61	0.69	3078
26	20	6.49	3.70	0.57	2907	6.05	3.45	0.57	3050	5.83	3.32	0.57	3135	5.61	3.20	0.57	3221
26	22	6.87	3.09	0.45	3021	6.43	2.89	0.45	3192	6.21	2.79	0.45	3249	5.99	2.69	0.45	3306
26	24	7.25	2.39	0.33	3135	6.80	2.25	0.33	3278	6.62	2.18	0.33	3349	6.43	2.12	0.33	3420
26	26	7.62	1.60	0.21	3249	7.18	1.51	0.21	3392	6.96	1.46	0.21	3463	6.74	1.42	0.21	3534
27	18	6.17	4.51	0.73	2793	5.67	4.14	0.73	2964	5.45	3.98	0.73	3021	5.23	3.82	0.73	3078
27	20	6.49	3.96	0.61	2907	6.05	3.69	0.61	3050	5.83	3.55	0.61	3135	5.61	3.42	0.61	3221
27	22	6.87	3.36	0.49	3021	6.43	3.15	0.49	3192	6.21	3.04	0.49	3249	5.99	2.93	0.49	3306
27	24	7.25	2.68	0.37	3135	6.80	2.52	0.37	3278	6.62	2.45	0.37	3349	6.43	2.38	0.37	3420
27	26	7.62	1.91	0.25	3249	7.18	1.80	0.25	3392	6.96	1.74	0.25	3463	6.74	1.69	0.25	3534
28	18	6.17	4.75	0.77	2793	5.67	4.37	0.77	2964	5.45	4.20	0.77	3021	5.23	4.03	0.77	3078
28	20	6.49	4.22	0.65	2907	6.05	3.93	0.65	3050	5.83	3.79	0.65	3135	5.61	3.64	0.65	3221
28	22	6.87	3.64	0.53	3021	6.43	3.41	0.53	3192	6.21	3.29	0.53	3249	5.99	3.17	0.53	3306
28	24	7.25	2.97	0.41	3135	6.80	2.79	0.41	3278	6.62	2.71	0.41	3349	6.43	2.63	0.41	3420
28	26	7.62	2.21	0.29	3249	7.18	2.08	0.29	3392	6.96	2.02	0.29	3463	6.74	1.95	0.29	3534
29	18	6.17	5.00	0.81	2793	5.67	4.59	0.81	2964	5.45	4.41	0.81	3021	5.23	4.24	0.81	3078
29	20	6.49	4.48	0.69	2907	6.05	4.17	0.69	3050	5.83	4.02	0.69	3135	5.61	3.87	0.69	3221
29	22	6.87	3.91	0.57	3021	6.43	3.66	0.57	3192	6.21	3.54	0.57	3249	5.99	3.41	0.57	3306
29	24	7.25	3.26	0.45	3135	6.80	3.06	0.45	3278	6.62	2.98	0.45	3349	6.43	2.89	0.45	3420
29	26	7.62	2.52	0.33	3249	7.18	2.37	0.33	3392	6.96	2.30	0.33	3463	6.74	2.22	0.33	3534
30	18	6.17	5.25	0.85	2793	5.67	4.82	0.85	2964	5.45	4.63	0.85	3021	5.23	4.44	0.85	3078
30	20	6.49	4.74	0.73	2907	6.05	4.42	0.73	3050	5.83	4.25	0.73	3135	5.61	4.09	0.73	3221
30	22	6.87	4.19	0.61	3021	6.43	3.92	0.61	3192	6.21	3.79	0.61	3249	5.99	3.65	0.61	3306
30	24	7.25	3.55	0.49	3135	6.80	3.33	0.49	3278	6.62	3.24	0.49	3349	6.43	3.15	0.49	3420
30	26	7.62	2.82	0.37	3249	7.18	2.66	0.37	3392	6.96	2.58	0.37	3463	6.74	2.49	0.37	3534
31	18	6.17	5.49	0.89	2793	5.67	5.05	0.89	2964	5.45	4.85	0.89	3021	5.23	4.65	0.89	3078
31	20	6.49	5.00	0.77	2907	6.05	4.66	0.77	3050	5.83	4.49	0.77	3135	5.61	4.32	0.77	3221
31	22	6.87	4.46	0.65	3021	6.43	4.18	0.65	3192	6.21	4.03	0.65	3249	5.99	3.89	0.65	3306
31	24	7.25	3.84	0.53	3135	6.80	3.61	0.53	3278	6.62	3.51	0.53	3349	6.43	3.41	0.53	3420
31	26	7.62	3.13	0.41	3249	7.18	2.94	0.41	3392	6.96	2.85	0.41	3463	6.74	2.76	0.41	3534
32	18	6.17	5.74	0.93	2793	5.67	5.27	0.93	2964	5.45	5.07	0.93	3021	5.23	4.86	0.93	3078
32	20	6.49	5.26	0.81	2907	6.05	4.90	0.81	3050	5.83	4.72	0.81	3135	5.61	4.54	0.81	3221
32	22	6.87	4.74	0.69	3021	6.43	4.43	0.69	3192	6.21	4.28	0.69	3249	5.99	4.13	0.69	3306
32	24	7.25	4.13	0.57	3135	6.80	3.88	0.57	3278	6.62	3.77	0.57	3349	6.43	3.66	0.57	3420
32	26	7.62	3.43	0.45	3249	7.18	3.23	0.45	3392	6.96	3.13	0.45	3463	6.74	3.03	0.45	3534

**NOTE:** Q: Total capacity (kW) SHF: Sensible heat factor DB: Dry-bulb temperature  
SHC: Sensible heat capacity (kW) INPUT: Total power input (W) WB: Wet-bulb temperature

PERFORMANCE DATA

WALL-MOUNTED

**HEAT operation (230V)****MSC-C07TV, MUH-C07TV**

CAPACITY : 2.5 kW INPUT : 710 W

INDOOR DB (°C)	OUTDOOR WB (°C)													
	-10		-5		0		5		10		15		20	
	Q	INPUT	Q	INPUT	Q	INPUT	Q	INPUT	Q	INPUT	Q	INPUT	Q	INPUT
15	1.58	462	1.90	554	2.23	625	2.55	675	2.88	717	3.18	738	3.50	753
21	1.50	497	1.80	589	2.13	653	2.43	703	2.75	738	3.05	760	3.36	788
26	1.35	533	1.68	625	1.98	689	2.30	738	2.63	774	2.93	795	3.25	817

**MSC-C09TV, MUH-C09TV**

CAPACITY : 3.2 kW INPUT : 960 W

INDOOR DB (°C)	OUTDOOR WB (°C)													
	-10		-5		0		5		10		15		20	
	Q	INPUT	Q	INPUT	Q	INPUT	Q	INPUT	Q	INPUT	Q	INPUT	Q	INPUT
15	2.02	624	2.43	749	2.85	845	3.26	912	3.68	970	4.06	998	4.48	1018
21	1.92	672	2.30	797	2.72	883	3.10	950	3.52	998	3.90	1027	4.30	1066
26	1.73	720	2.14	845	2.53	931	2.94	998	3.36	1046	3.74	1075	4.16	1104

**MSC-C12TV, MUH-C12TV**

CAPACITY : 4.2 kW INPUT : 1370 W

INDOOR DB (°C)	OUTDOOR WB (°C)													
	-10		-5		0		5		10		15		20	
	Q	INPUT	Q	INPUT	Q	INPUT	Q	INPUT	Q	INPUT	Q	INPUT	Q	INPUT
15	2.65	891	3.19	1069	3.74	1206	4.28	1302	4.83	1384	5.33	1425	5.88	1452
21	2.52	959	3.02	1137	3.57	1260	4.07	1356	4.62	1425	5.12	1466	5.65	1521
26	2.27	1028	2.81	1206	3.32	1329	3.86	1425	4.41	1493	4.91	1534	5.46	1576

**MSH-C18TV, MUH-C18TV**

CAPACITY : 6.0 kW INPUT : 2180 W

INDOOR DB (°C)	OUTDOOR WB (°C)													
	-10		-5		0		5		10		15		20	
	Q	INPUT	Q	INPUT	Q	INPUT	Q	INPUT	Q	INPUT	Q	INPUT	Q	INPUT
15	3.78	1417	4.56	1700	5.34	1918	6.12	2071	6.90	2202	7.62	2267	8.40	2311
21	3.60	1526	4.32	1809	5.10	2006	5.82	2158	6.60	2267	7.32	2333	8.07	2420
26	3.24	1635	4.02	1918	4.74	2115	5.52	2267	6.30	2376	7.02	2442	7.80	2507

**MSH-C24TV, MUH-C24TV**

CAPACITY : 7.5 kW INPUT : 3020 W

INDOOR DB (°C)	OUTDOOR WB (°C)													
	-10		-5		0		5		10		15		20	
	Q	INPUT	Q	INPUT	Q	INPUT	Q	INPUT	Q	INPUT	Q	INPUT	Q	INPUT
15	4.73	1963	5.70	2356	6.68	2658	7.65	2869	8.63	3050	9.53	3141	10.50	3201
21	4.50	2114	5.40	2507	6.38	2778	7.28	2990	8.25	3141	9.15	3231	10.09	3352
26	4.05	2265	5.03	2658	5.93	2929	6.90	3141	7.88	3292	8.78	3382	9.75	3473

**NOTE:** Q: Total capacity (kW) INPUT: Total power input (W) DB: Dry-bulb temperature WB: Wet-bulb temperature

# B.1.7 NOISE CRITERIA CURVES

## B.1.7.1 Cool Only/Heat Pump

MSC-C07TV  
MSC-C09TV

NOTCH	SPL(dB(A))	LINE
High	36	●—●

Test conditions,  
Cooling : Dry-bulb temperature 27°C Wet-bulb temperature 19°C  
Heating : Dry-bulb temperature 20°C

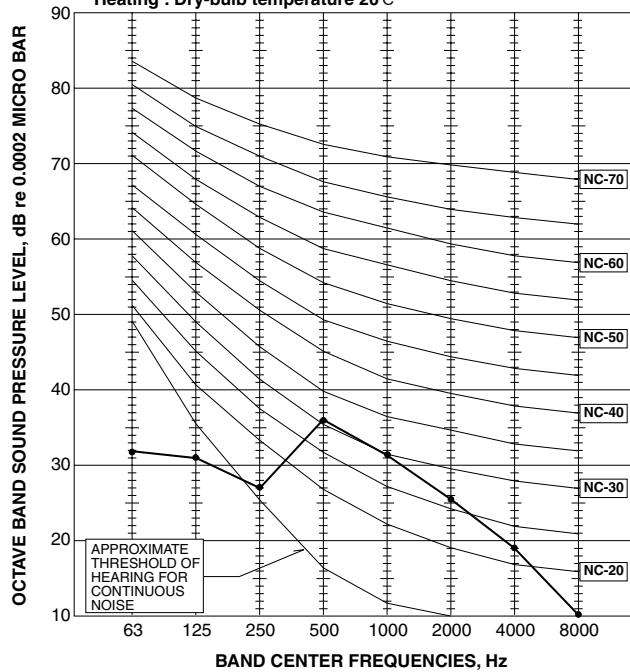

MSC-C12TV

NOTCH	SPL(dB(A))	LINE
High	39	●—●

Test conditions,  
Cooling : Dry-bulb temperature 27°C Wet-bulb temperature 19°C  
Heating : Dry-bulb temperature 20°C

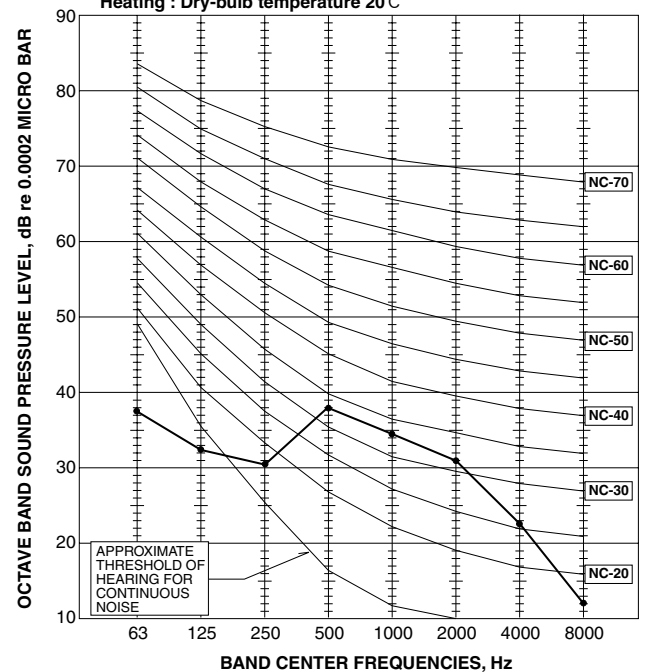

MU-C07TV  
MU-C09TV

NOTCH	SPL(dB(A))	LINE
High	45	●—●

Test conditions,  
Cooling : Dry-bulb temperature 35°C Wet-bulb temperature 24°C

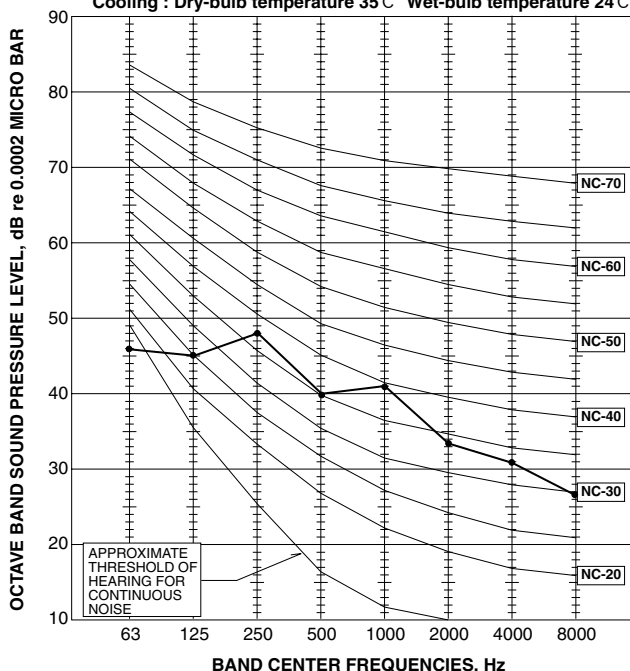

MU-C12TV

NOTCH	SPL(dB(A))	LINE
High	49	●—●

Test conditions,  
Cooling : Dry-bulb temperature 35°C Wet-bulb temperature 24°C

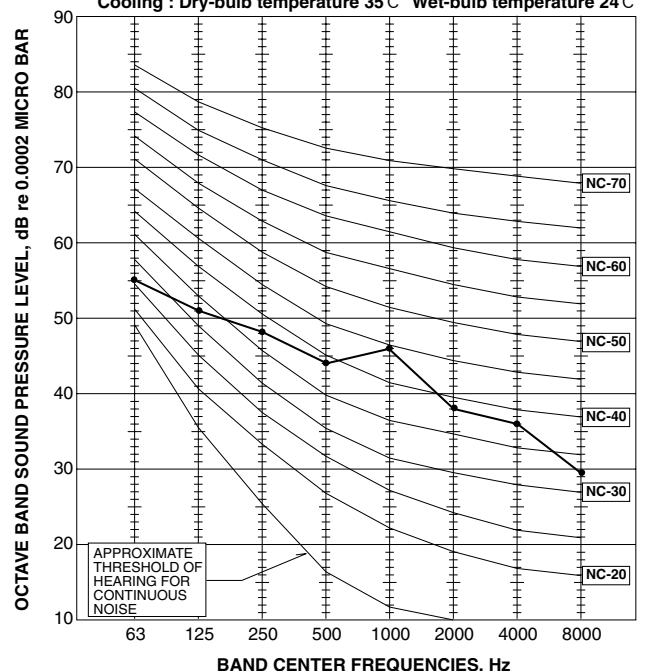

WALL-MOUNTED NOISE CRITERIA CURVES

**MUH-C07TV**

NOTCH	SPL(dB(A))	LINE
High	47	●—●

Test conditions,

Heating : Dry-bulb temperature 7°C Wet-bulb temperature 6°C

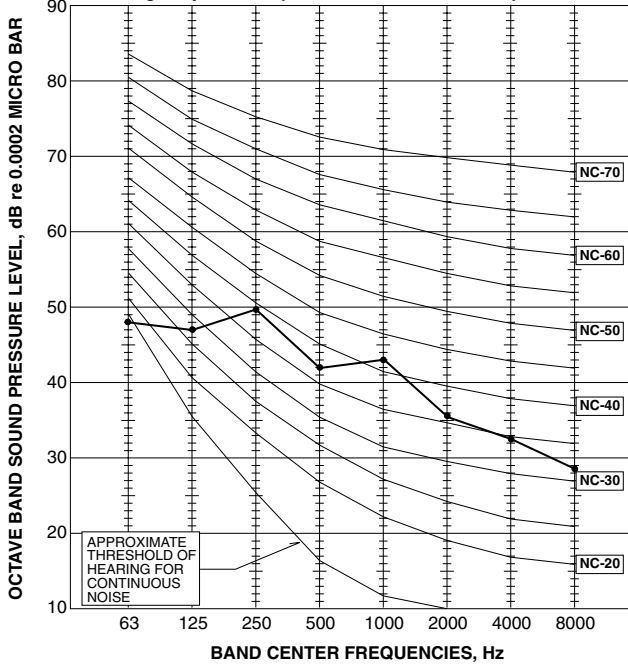

**MUH-C12TV**

NOTCH	SPL(dB(A))	LINE
High	49	●—●

Test conditions,

Heating : Dry-bulb temperature 7°C Wet-bulb temperature 6°C

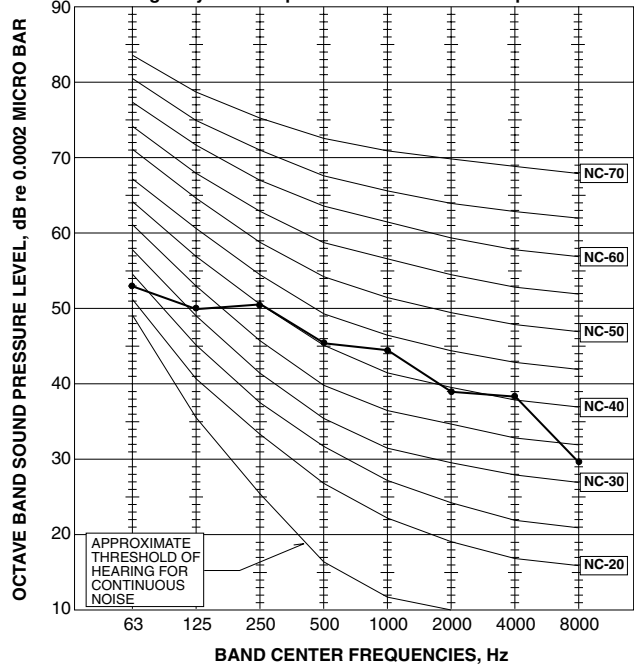

**MUH-C09TV**

NOTCH	SPL(dB(A))	LINE
High	49	●—●

Test conditions,

Heating : Dry-bulb temperature 7°C Wet-bulb temperature 6°C

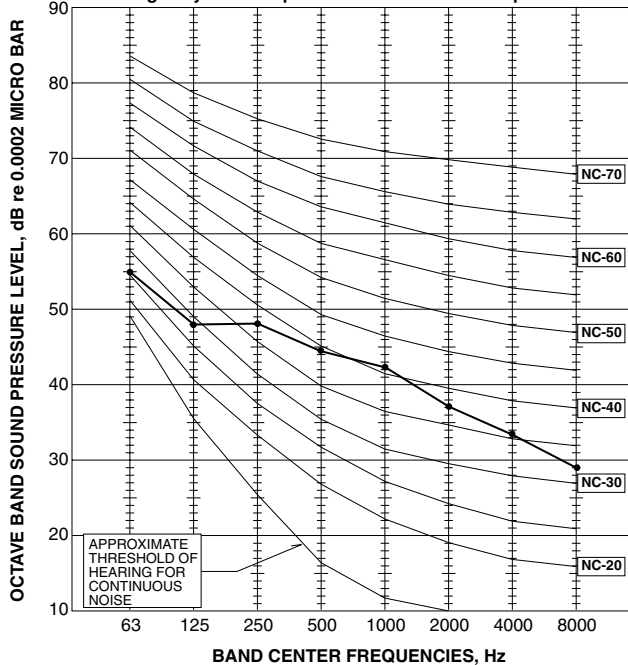

NOISE CRITERIA CURVES

WALL-MOUNTED



MS-C18TV

NOTCH	SPL(dB(A))	LINE
High	42	

Test conditions,  
Cooling : Dry-bulb temperature 27°C Wet-bulb temperature 19°C

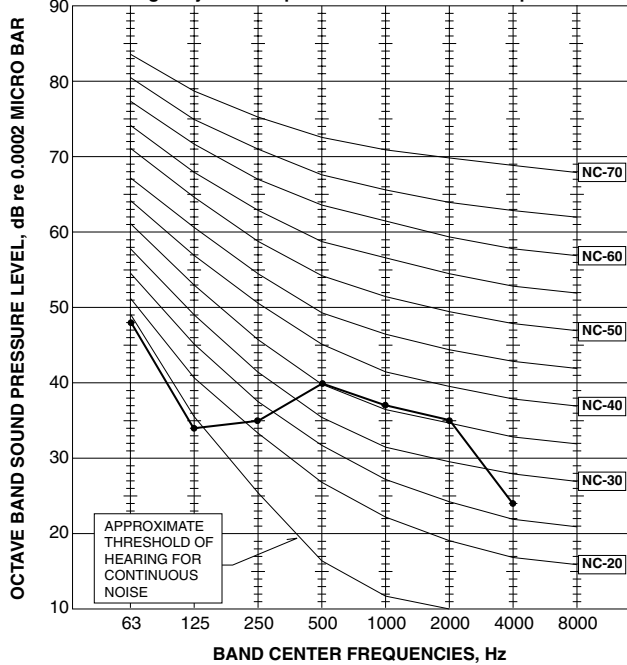

MS-C24TV

NOTCH	SPL(dB(A))	LINE
High	45	

Test conditions,  
Cooling : Dry-bulb temperature 27°C Wet-bulb temperature 19°C

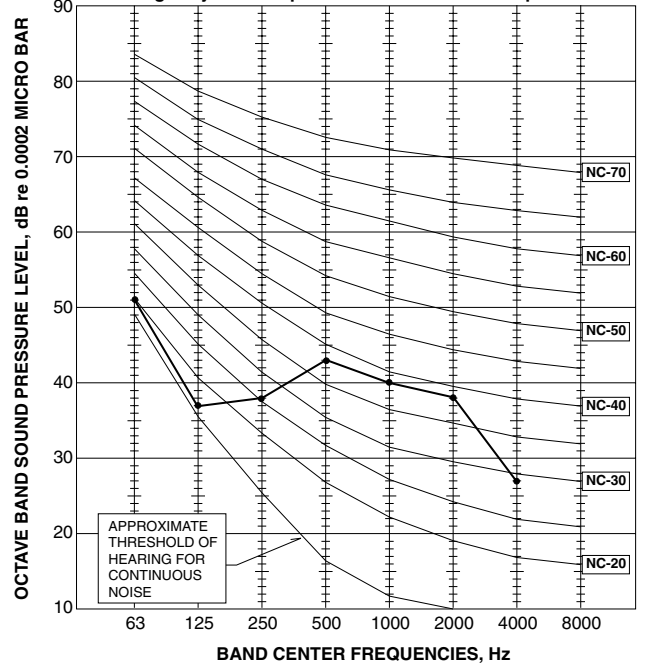

MU-C18TV

NOTCH	SPL(dB(A))	LINE
High	52	

Test conditions,  
Cooling : Dry-bulb temperature 35°C Wet-bulb temperature 24°C

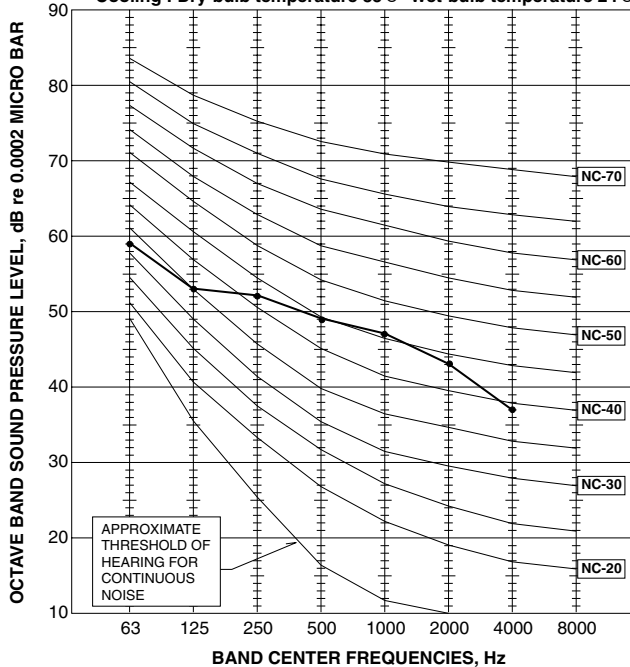

MU-C24TV

NOTCH	SPL(dB(A))	LINE
High	53	

Test conditions,  
Cooling : Dry-bulb temperature 35°C Wet-bulb temperature 24°C

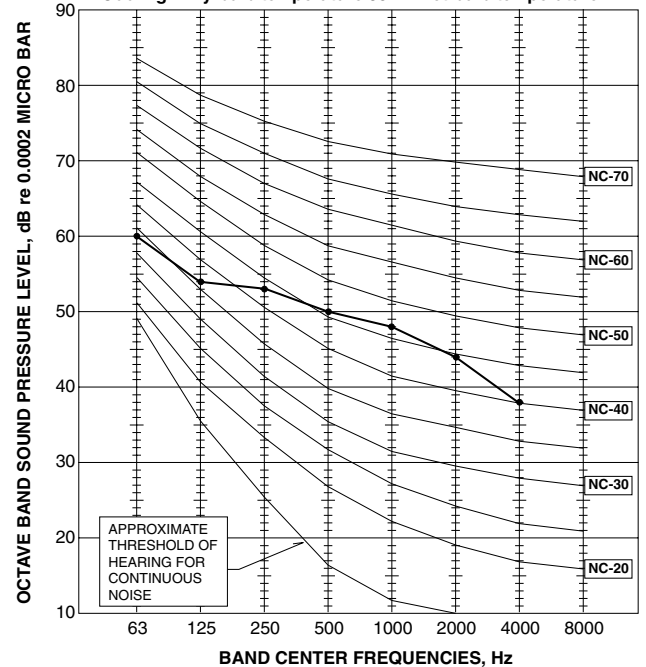

WALL-MOUNTED NOISE CRITERIA CURVES

**MSH-C18TV**

NOTCH	SPL(dB(A))	LINE
High	42	

Test conditions,

Cooling : Dry-bulb temperature 27°C Wet-bulb temperature 19°C  
 Heating : Dry-bulb temperature 20°C Wet-bulb temperature 15.5°C

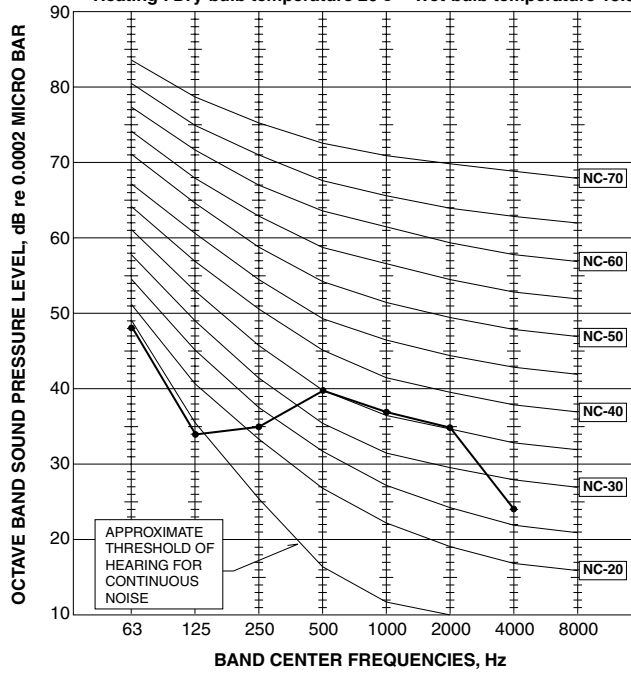

**MSH-C24TV**

NOTCH	SPL(dB(A))	LINE
High	45	

Test conditions,

Cooling : Dry-bulb temperature 27°C Wet-bulb temperature 19°C  
 Heating : Dry-bulb temperature 20°C Wet-bulb temperature 15.5°C

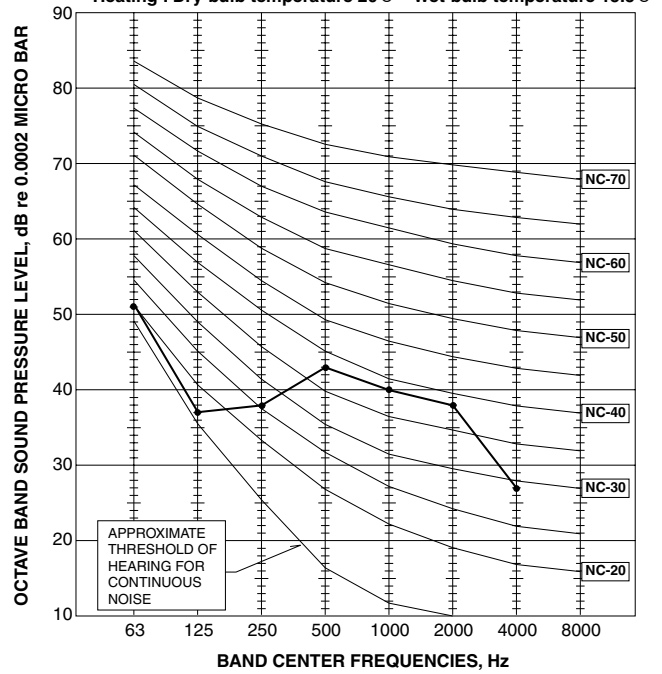

**MUH-C18TV**

NOTCH	SPL(dB(A))	LINE
High	52	

Test conditions,

Cooling : Dry-bulb temperature 35°C Wet-bulb temperature 24°C  
 Heating : Dry-bulb temperature 7°C Wet-bulb temperature 6°C

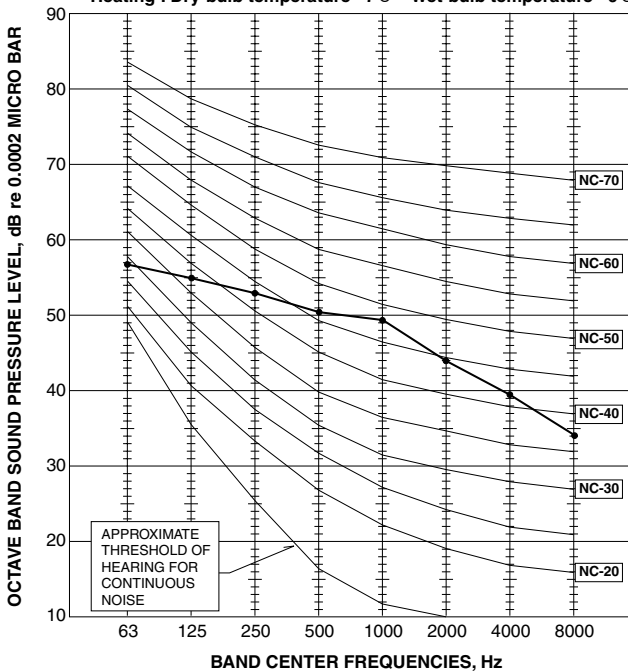

**MUH-C24TV**

NOTCH	SPL(dB(A))	LINE
High	53	

Test conditions,

Cooling : Dry-bulb temperature 35°C Wet-bulb temperature 24°C  
 Heating : Dry-bulb temperature 7°C Wet-bulb temperature 6°C

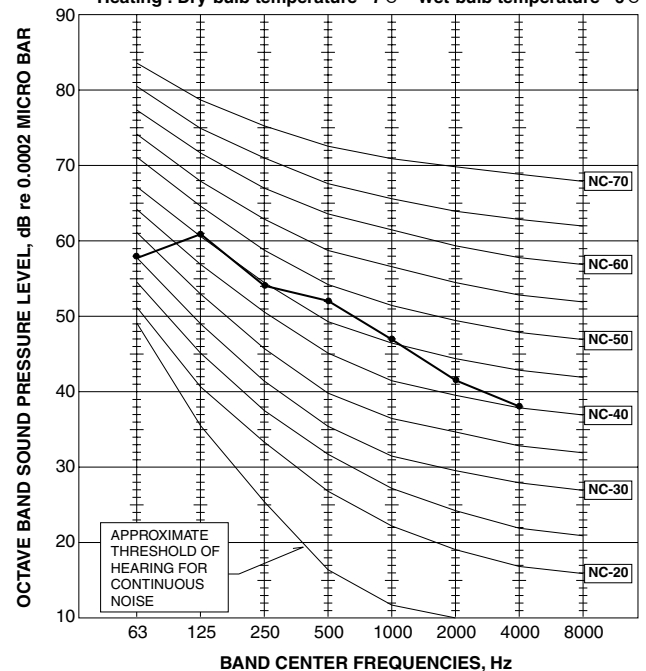

NOISE CRITERIA CURVES WALL-MOUNTED

## B.1.8 REMOTE CONTROLLER OPERATION

### B.1.8.1 MSC Type

MSC-C07TV  
 MSC-C09TV  
 MSC-C12TV

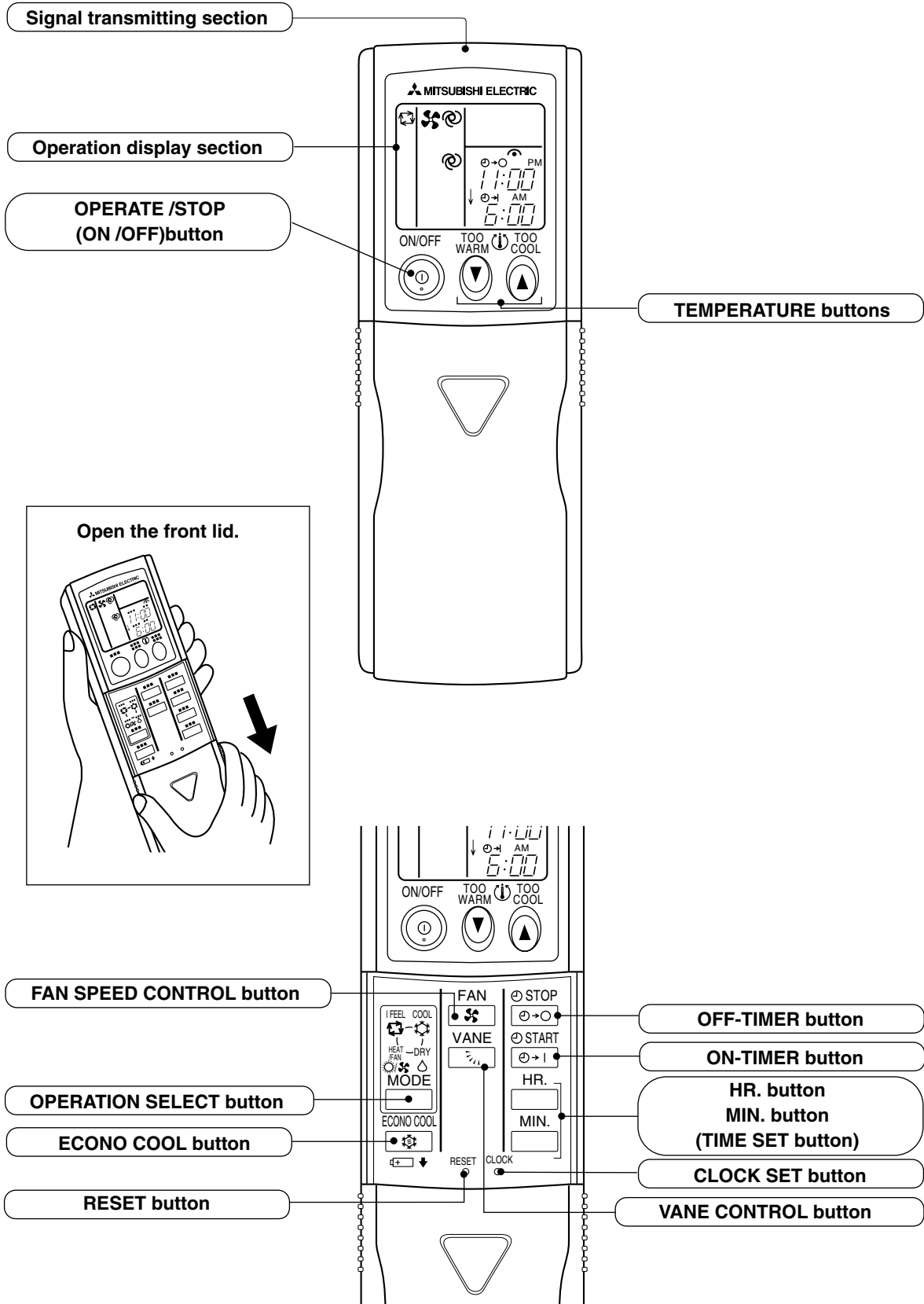

WALL-MOUNTED REMOTE CONTROLLER OPERATION

B.1.8.2 Cool Only

MS-C18TV  
MS-C24TV

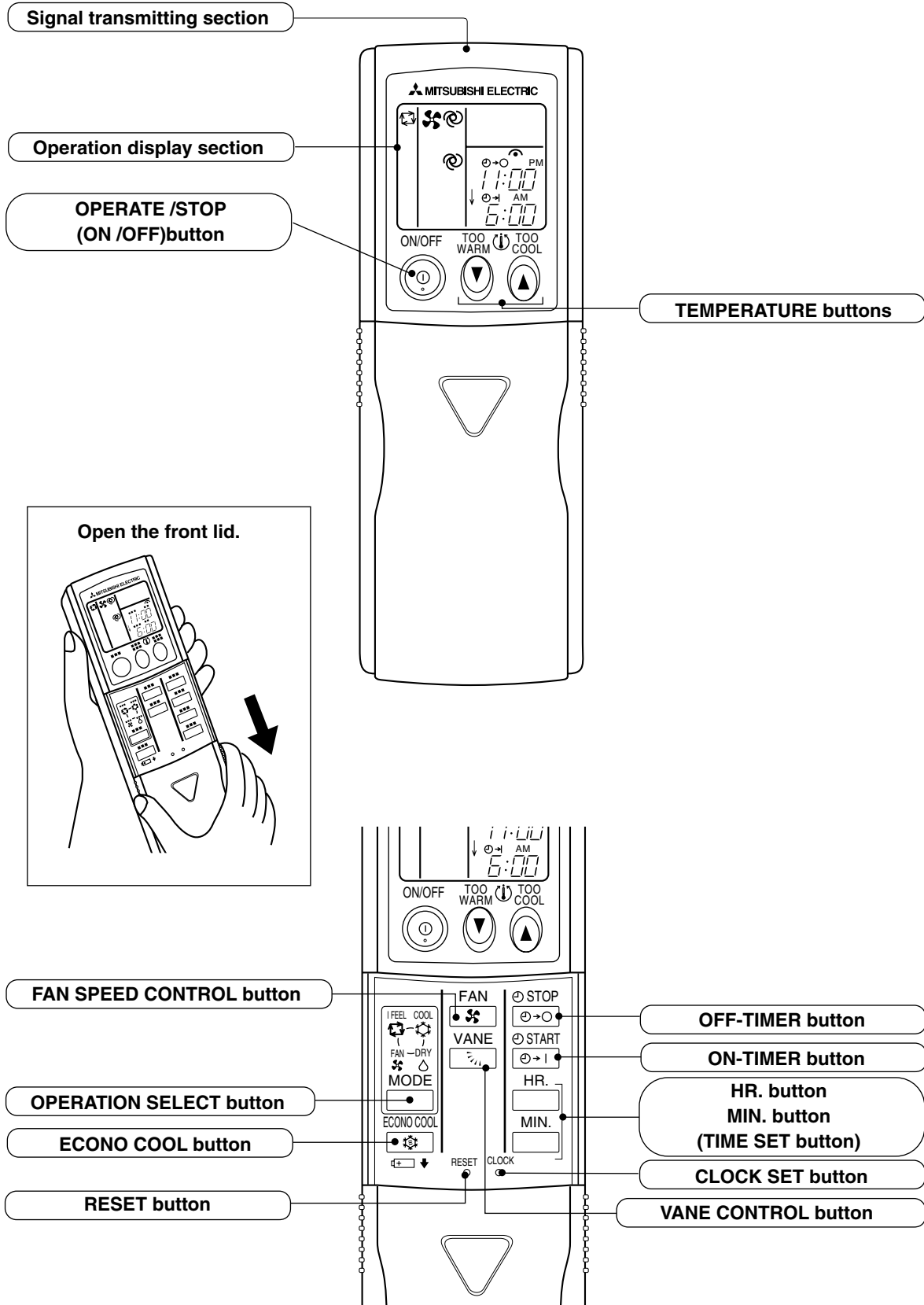

REMOTE CONTROLLER OPERATION

WALL-MOUNTED

B.1.8.3 Heat Pump

MSH-C18TV  
MSH-C24TV

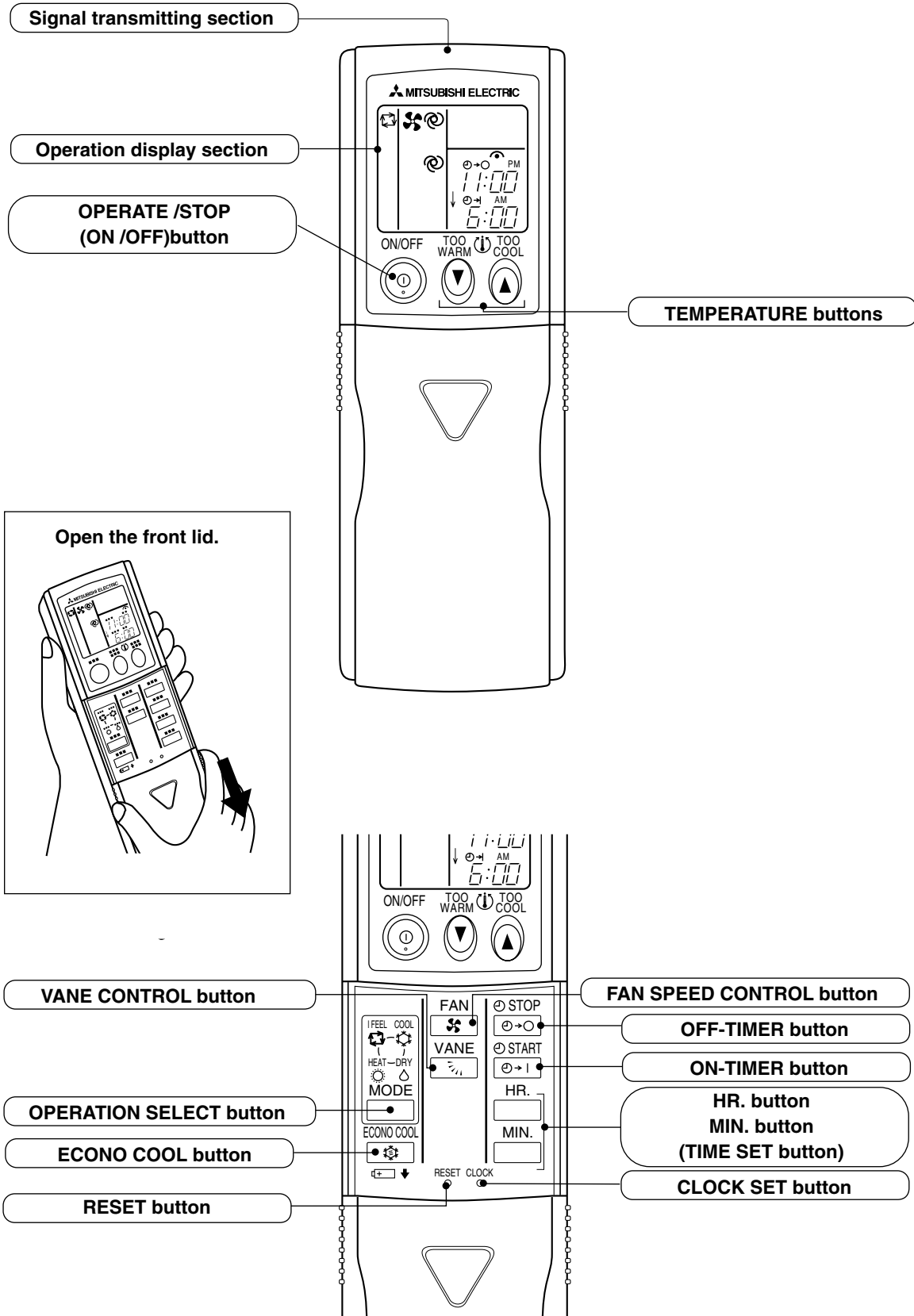

WALL-MOUNTED REMOTE CONTROLLER OPERATION

## B.1.9 TROUBLESHOOTING

MSC-C07TV  
MSC-C09TV  
MSC-C12TV

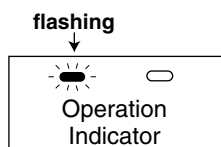

- Flashing of the OPERATION INDICATOR lamp (on the left-hand side) indicates possible abnormalities.
- The OPERATION INDICATOR lamp (on the left-hand side) is lighting during normal operation.

Before taking measures, make sure that the symptom reappears, for accurate troubleshooting.

Self check table

No.	Abnormal point	Indication	Symptom	Detect method	Check point
1	Mis-wiring	0.5-second ON ●●●●●● 0.5-second OFF	Outdoor unit does not run.	When serial signal stops for 4 to 5 seconds after 1st on of 52C contactor by POWER turning on.	<ul style="list-style-type: none"> <li>● Check switch SW2-②.(MU type or MUH type)</li> <li>● Check wiring (visual check and conductivity check).</li> <li>● Check indoor electronic control P.C. board.</li> <li>● Check outdoor deicer P.C. board.</li> <li>● Check electrical parts.</li> </ul>
	Serial signal	1-time flash ●○○○○○○●○○○○○○●○○ 2.5-second OFF		When serial signal from outdoor unit stops for 4 to 5 seconds.	
2	Indoor coil thermistor	2-time flash ●●●○○○○○○●●●○○ 2.5-second OFF	Outdoor unit does not run.	Detect Indoor coil/room temperature thermistor short or open circuit every 8 seconds during operation.	<ul style="list-style-type: none"> <li>● Check resistance of thermistor.</li> <li>● Re-connect connector.</li> <li>● Check indoor electronic control P.C. board.</li> </ul>
	Room temperature thermistor				
3	Indoor fan motor	3-time flash ●●●●●●○○○○○○●●●○○○○ 2.5-second OFF	Indoor fan motor repeats 12 seconds ON and 3 minutes OFF. When the indoor fan motor breaks, the fan keeps stopping.	When rotational frequency feedback pulse signal is not emit during 12-second indoor fan operation.	<ul style="list-style-type: none"> <li>● Disconnect connector CN211 and then check connector CN121 ②-③ to make sure rotational frequency feedback signal of 1.5V or over exists.</li> <li>● Check indoor electronic control P.C. board.</li> <li>● Check indoor fan motor.</li> <li>● Re-connect connector.</li> </ul>
4 *	Defrost thermistor	6-time flash ●●●●●●○○○○○○●○○○○○○●○○ 2.5-second OFF	Outdoor unit does not run.	When the defrost thermistor shorts or opens after the compressor start-up.	<ul style="list-style-type: none"> <li>● Check outdoor deicer P.C. board.</li> <li>● Check resistance of thermistor.</li> <li>● Re-connect connector.</li> </ul>

NOTE: \* The indication is only for MUH-C07/C09/C12TV.

TROUBLESHOOTING

WALL-MOUNTED

**MS-C18TV**  
**MS-C24TV**

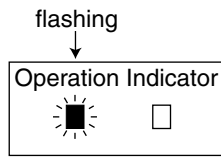

- Flashing of the OPERATION INDICATOR lamp (on the left-hand side) indicates possible abnormalities.
- The OPERATION INDICATOR lamp (on the left-hand side) is lighting during normal operation.

Before taking measures make sure that the symptom reappears, for accurate troubleshooting.

Self check table

No.	Abnormal point	Indication	Symptom	Detect method	Check point
1	Indoor coil thermistor	2-time flash  2.5-second OFF	Outdoor unit does not run.	Detect Indoor coil/room temperature thermistor short or open circuit every 8 seconds during operation.	<ul style="list-style-type: none"> <li>● Check thermistor calibration.</li> <li>● Re-connect connector.</li> <li>● Check indoor electronic control P.C. board.</li> </ul>
	Room temperature thermistor				
2	Indoor fan motor	3-time flash  2.5-second OFF	Indoor fan motor repeats 12 seconds ON and 3 minutes OFF. When the indoor fan motor breaks, the fan keeps stopping.	When rotational frequency feedback signal is not emit during 12-second indoor fan operation.	<ul style="list-style-type: none"> <li>● Disconnect connector CN211 and then check connector CN121 ②-③ to make sure rotational frequency feedback signal of 1.5V or over exists.</li> <li>● Check indoor electronic control P.C. board.</li> <li>● Check indoor fan motor.</li> <li>● Re-connect connector.</li> </ul>

**MSH-C18TV**  
**MSH-C24TV**

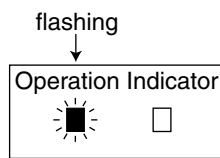

- Flashing of the OPERATION INDICATOR lamp (on the left-hand side) indicates possible abnormalities.
- The OPERATION INDICATOR lamp (on the left-hand side) is lighting during normal operation.

Before taking measures, make sure that the symptom reappears, for accurate troubleshooting.  
Self check table

No.	Abnormal point	Indication	Symptom	Detect method	Check point
1	Mis-wiring	0.5-second ON ●●●●●● 0.5-second OFF	Outdoor unit does not run.	When serial signal stops for 4 to 5 seconds after 1st on of 52C contactor by POWER turning on.	<ul style="list-style-type: none"> <li>● Check wiring (visual check and conductivity check).</li> <li>● Check indoor electronic control P.C.board.</li> <li>● Check deicer P.C. board.</li> <li>● Check electrical parts.</li> </ul>
	Serial signal	1-time flash ●○○○○○●○○○○○●○○ 2.5-second OFF		When serial signal from outdoor unit stops for 4 to 5 seconds.	
2	Indoor coil thermistor	2-time flash ●●○○○○○●●○○○ 2.5-second OFF	Outdoor unit does not run.	Detect Indoor coil/room temperature thermistor short or open circuit every 8 seconds during operation.	<ul style="list-style-type: none"> <li>● Check resistance of thermistor.</li> <li>● Re-connect connector.</li> <li>● Check indoor electronic control P.C.board.</li> </ul>
	Room temperature thermistor				
3	Indoor fan motor	3-time flash ●●●●○○○○○●●●○○○ 2.5-second OFF	Indoor fan motor repeats 12 seconds ON and 3 minutes OFF. When the indoor fan motor breaks, the fan keeps stopping.	When rotational frequency feedback pulse signal is not emit during 12-second indoor fan operation.	<ul style="list-style-type: none"> <li>● Disconnect connector CN211 and then check connector CN121 ②-③ to make sure rotational frequency feedback signal of 1.5V or over exists.</li> <li>● Check indoor electronic control P.C. board.</li> <li>● Check indoor fan motor.</li> <li>● Re-connect connector.</li> </ul>
4	Outdoor thermistor	6-time flash ●●●●●●○○○○○●○○○ 2.5-second OFF	Outdoor unit does not run.	When the defrost thermistor shorts or opens after the compressor start-up.	<ul style="list-style-type: none"> <li>● Check deicer P.C. board.</li> <li>● Check resistance of thermistor.</li> <li>● Re-connect connector.</li> </ul>
5	<b>MSH-C24TV only</b> Outdoor control system	7-time flash ●●●●●●○○○○○●○○○ 2.5-second OFF	Outdoor unit does not run.	When nonvolatile memory data cannot be read properly on deicer P.C. board, outdoor unit stops and restarts 3 minutes later.	<ul style="list-style-type: none"> <li>● Replace deicer P.C. board.</li> </ul>

TROUBLESHOOTING

WALL-MOUNTED



# B.1.10 INSTALLATION PROCEDURE

## B.1.10.1 Cool Only/Heat Pump

### MSC-C07/C09/C12TV

#### INSTALLATION DIAGRAM & ACCESSORIES

##### FLARED CONNECTIONS

- This unit has flared connections on both indoor and outdoor sides.
- Remove the outdoor units valve cover, then connect the pipe.
- Refrigerant pipes are used to connect the indoor and outdoor units.

Limits		
Pipe length	07/09 type	10 m max.
	12 type	15 m max.
Height difference	07/09 type	5 m max.
	12 type	
No. of bends	07/09 type	10 max.
	12 type	

- Refrigerant adjustment ... If pipe length exceeds 7 m, additional refrigerant (R407C) charge is required. (The outdoor unit is charged with refrigerant for pipe length up to 7 m.)

Pipe length	Up to 7 m	No additional charge is required.
	Exceeding 7 m	Additional charge is required. (Refer to the table below.)
Refrigerant to be added	MS type	15 g × (refrigerant piping length (m) - 7)
	MSH type	25 g × (refrigerant piping length (m) - 7)

##### ACCESSORIES

Check the following parts before installation.

<Indoor unit>

1	Installation plate	1
2	Installation plate fixing screw 4 × 25 mm	5
3	Remote controller mounting hardware	1
4	Fixing screw for 3.5 × 16 mm (Black)	2
5	Battery (AAA) for remote controller	2
6	Wireless remote controller	1
7	Felt tape (Used for left or left-rear piping)	1
8	Deodorizing filter	1
9	Air cleaning filter	1
10	Refrigeration oil	1

<Outdoor unit: MUH type>

11	Drain socket	1
12	Drain cap φ33	2

##### PART TO BE PROVIDED AT YOUR SITE

Optional extension pipe

A	Indoor/outdoor unit connecting wire (2-core 1.0-1.5 mm <sup>2</sup> )	1
B	Extension pipe	1
C	Wall hole sleeve	1
D	Wall hole cover	1
E	Pipe fixing band (The quantity depends on the pipe length.)	2 to 5
F	Fixing screw for 4 × 20 mm (The quantity depends on the pipe length.)	2 to 5
G	Piping tape	1
H	Putty	1
I	Drain hose (or soft PVC hose, 15 mm inner dia. or hard PVC pipe VP16)	1
J	Power supply cord (1.0-1.5 mm <sup>2</sup> )	1

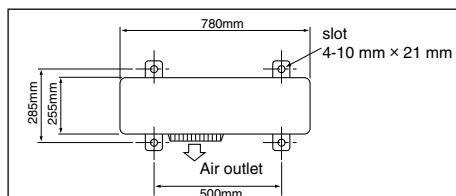

##### PIPING PREPARATION

- Refrigerant pipes of 3.5, 7 and 10 m (for 07/09 type) 3.5, 7, 10 and 15 m (for 12 type) are available as optional items.

① Table below shows the specifications of pipes commercially available.

Pipe	Outside diameter		Insulation thickness	Insulation material
	mm			
For liquid	6.35		8	Heat resisting foam plastic specific gravity 0.045
For gas	07/09 type	9.52	8	
	12 type	12.7	8	

- ② Ensure that the 2 refrigerant pipes are insulated to prevent condensation.
- ③ Refrigerant pipe bending radius must be 100 mm or more.

##### CAUTION

Use care to insulation of specified thickness. Excessive thickness prevents storage behind the indoor unit and lack of thickness causes dew drippage.

Decide the installation position using mark on the installation plate indicating the indoor unit size as reference.

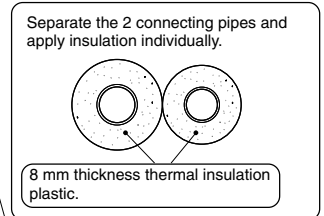
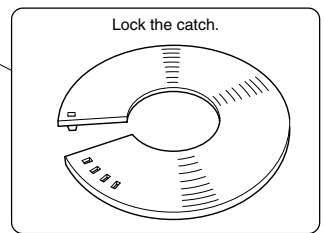
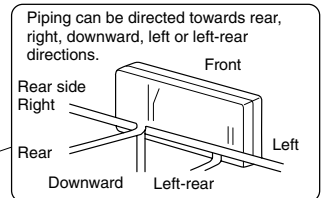
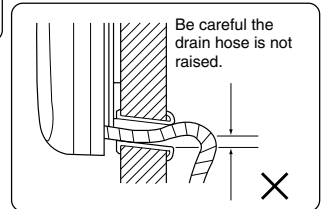
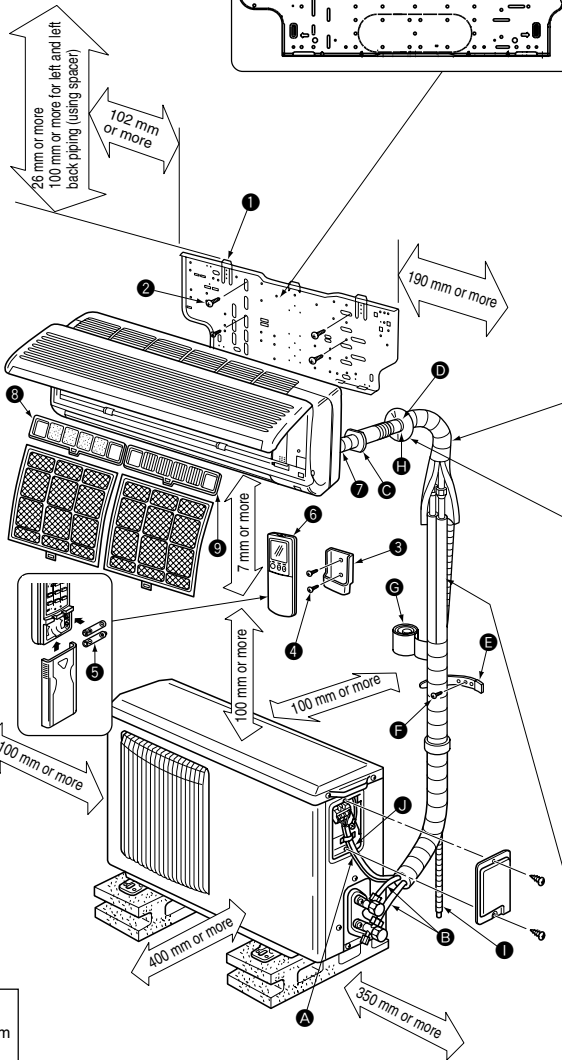
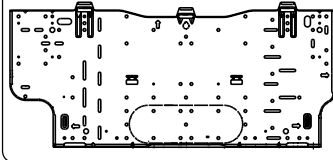

When the piping is to be attached to a wall containing metals (tin plated) or metal netting, use a chemically treated wooden piece 20 mm or thicker between the wall and the piping or wrap 7 to 8 turns of insulation vinyl tape around the piping.

Units should be installed by licensed contractor according to local code requirement.

**POWER SUPPLY AND CONNECTING WIRE SPECIFICATIONS**

- Use special room air conditioning circuit.

Power supply cord length (Lead to left/Lead to right)	0.3 m/1 m
Indoor and Outdoor connecting wire Specification	Cable 2-core 1.0-1.5 mm <sup>2</sup>

- Take out power supply cord from the left or right bottom corner of the indoor unit.

Connect to the plug, or to a power switch which has a gap of 3 mm or more when open to interrupt the source power phase.  
(Input capacity Main switch/Fuse:10 A)  
(This plug has to be the one meets the Standards.)

Power supply cord

Green/Yellow : Earth  
Blue : N  
Brown : L

**⚠ WARNING**

Never cut the power cord and connect to other wires.  
It may cause a fire.

Do not bundle the spare wire, but house it as shown in the figure below.

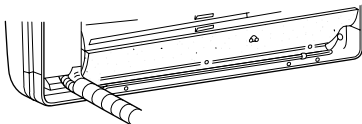

**INDOOR AND OUTDOOR CONNECTING WIRE CONNECTION (BEFORE HOOKING THE UNIT)**

You can connect indoor/outdoor lead wire without removing the front panel.

- ① Open the front grille of the front panel.
- ② Remove one screw holding the electrical cover, then remove the cover.
- ③ Remove one screw holding the electrical wire, then remove the fixture.
- ④ In case the outdoor unit is MU type, change the setting of SW2.
- ⑤ Pass the indoor/outdoor unit connecting wire from the back of the indoor unit and process the end of the wire, then connect it to the terminal block.
- ⑥ Replace the fixture and electrical cover securely.

Securely push the electrical wire into the terminal block until no part of its core is appeared.

<Connection details>

**⚠ CAUTION**

- Use care not to make mis-wiring.
- Firmly tighten the terminal screws to prevent them from loosening.
- After tightening, pull the wires lightly and confirm that they do not move.

**⚠ CAUTION**

- Common specifications for MS type and MSH type are provided against the indoor unit and the remote controller. They are set up for MSH type when they are shipped from the factory. In order to switch over the setting to MS type, change SW2-② and SLIDE SWITCH as following figures.

- If the terminal block is connected incorrectly, the unit does not operate normally.
- If an earth is incorrect, it may cause an electric shock.

**⚠ WARNING**

- Use the indoor/outdoor unit connecting wire that meets the Standards to connect the indoor and outdoor units and fix the wire to the terminal block securely so that no external force is conveyed to the connecting section of the terminal block. Incomplete connection or fixing of the wire could result in a fire.
- Attach the electrical cover securely. If it is attached incorrectly, it could result in a fire or an electric shock due to dust, water, etc.

**HOW TO SWITCH OVER MS TYPE/MSH TYPE AND AUTO RESTART FUNCTION**

**<INDOOR ELECTRIC P.C. BOARD>**

**The details of SW2**

SW2-① sets up AUTO RESTART FUNCTION ON/OFF.  
SW2-② switches over MS type/MSH type.  
When the units are shipped from the factory, SW2 is set up as following.  
SW2-①: AUTO RESTART FUNCTION OFF (upside)  
SW2-②: MSH type (downside)

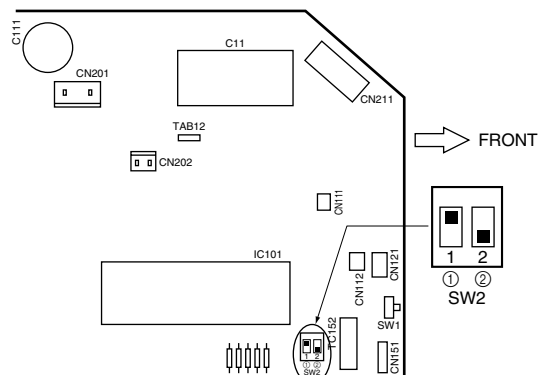

	CONDITION	SW2
How to switch over MS type/MSH type	Outdoor unit MU type SW2-② : upside	
	Outdoor unit MUH type SW2-② : downside	
How to set the AUTO RESTART FUNCTION	AUTO RESTART FUNCTION ON SW2-① : downside	

**Notes: (How to take out the indoor electronic P.C. board)**

- Remove the front panel.
- Remove the screws of the electrical cover.  
Remove the electrical cover.
- Remove the terminal cover.  
Remove the screw of the terminal block.
- Remove the cord clamp.
- Disconnect all the connectors on the electronic control P.C. board.
- Remove the screw of the earth wire.
- Disconnect all the lead wires from TAB12.
- Remove the electronic control P.C. board and the display P.C. board from the electrical box.

**Notes: (AUTO RESTART FUNCTION)**

- When the indoor unit is controlled with the remote controller, the operation mode, set temperature, and the fan speed are memorized by the indoor electronic control P.C. board. The auto restart function sets to work the moment the power has restored after power failure, then, the unit will restart automatically. If the unit is operated in "I FEEL CONTROL" mode before power failure, the operation is not memorized. In "I FEEL CONTROL" mode, the operation is decided by the initial room temperature at (re)start.
- If the main power (230V AC) has been cut, the operation settings remain.
- When three minutes have passed after power was restored, the unit will restart automatically according to the memory.
- The operation settings are memorized when 10 seconds have passed after the remote controller was operated.
- If the main power is turned off or a power failure occurs while AUTO START/STOP timer is active, the timer setting is cancelled. As this model is equipped with the auto restart function, the air conditioner should start operating at the same time that a power has restored.
- If the unit has been off with the remote controller before power failure, the auto restart function does not work as the power button of the remote controller is off.
- To prevent breaker off due to the rush of starting current, systematize other home appliance not to turn on at the same time.

**HOW TO SWITCH OVER MS TYPE/MSH TYPE <REMOTE CONTROLLER>**

**The details of SLIDE SWITCH**

- Pull out the upper lid.
- Set the SLIDE SWITCH in the battery place with a pen tip as shown in the table below. The switch is set up for "COOL & HEAT (Left side)", when the units are shipped from the factory.

	COOL & HEAT (MUH Type)	COOL ONLY (MU Type)
HOW TO SWITCH OVER MS TYPE/MSH TYPE		
	SLIDE SWITCH	SLIDE SWITCH

- Put the two batteries (AAA) in the place.
- Fix the upper lid.
- Press the reset button with a pen, etc.

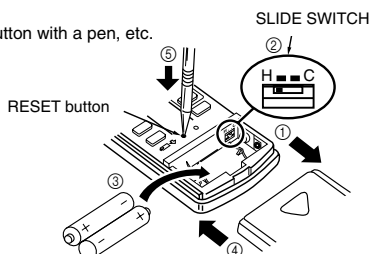

**OUTDOOR UNIT INSTALLATION**

**INDOOR/OUTDOOR WIRE CONNECTION AND OUTDOOR POWER SUPPLY CORD CONNECTION**

- Connect the indoor/outdoor unit connecting wire ① from the indoor unit correctly on the terminal block.
- For aftercare maintenance, give extra length to connecting wire.

- Peel off both ends of connecting wire (extension wire). When too long, or connected by cutting off the middle, peel off power supply wire to the size as shown in the right.
- Be careful not to contact connecting wire with piping.

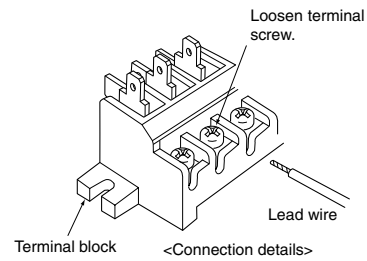

**Outdoor unit COOL ONLY MU type**

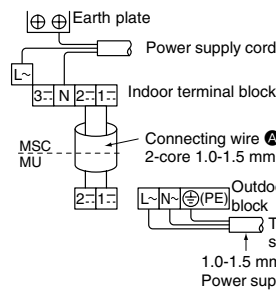

**Outdoor unit COOL & HEAT MUH type**

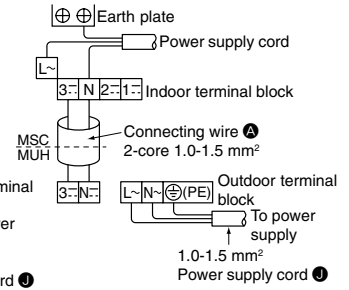

**CAUTION**

- Use care not to make mis-wiring.
- Firmly tighten the terminal screws to prevent them from loosening.
- After tightening, pull the wires lightly to confirm that they do not move.

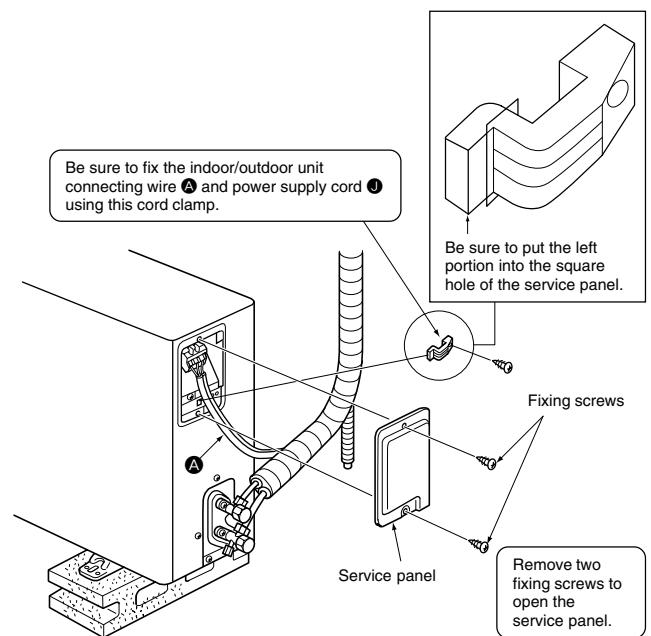

**WARNING**

Be sure to attach the service panel of the outdoor unit securely. If it is not attached correctly, it could result in a fire or an electric shock due to dust, water, etc.

**DRAIN PIPING**

- The drain hose should point downward for easy drain flow. (Fig. 1)  
Do not make drain piping as shown in Fig. 2 to 5.

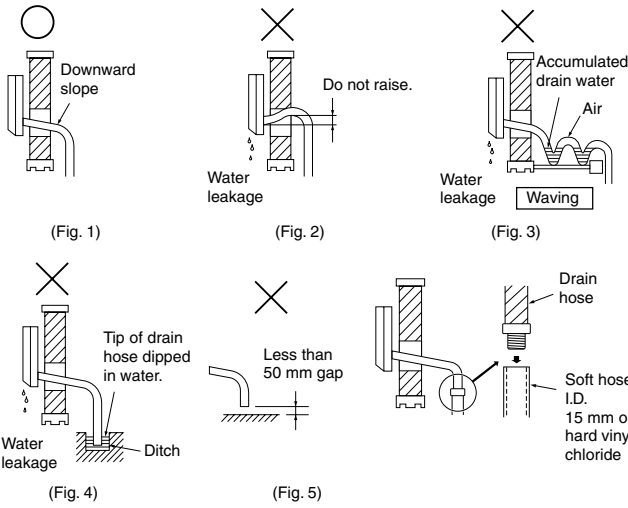

- If the drain hose provided with the indoor unit is too short, connect with drain hose ① in the part to be provided at your site.
- If the extension drain hose has to pass through a room, be sure to wrap with commercially sold insulation.

**TEST RUN**

**COOL ONLY MU type**

- Before performing the test run, recheck for any wrong wiring. Wrong wiring prevents normal operation or results in blown fuse disabling operation.
- The test run can be started by pressing EMERGENCY OPERATION switch. When the EMERGENCY OPERATION switch is once pressed, the unit will start the test run (continuous operation) for 30 minutes. A thermostat does not work during this time. After 30 minutes the unit will start the EMERGENCY OPERATION at a fixed temperature setting of 24°C in COOL MODE.
- Perform test run in the following procedure.

**PROCEDURE**

- Press the EMERGENCY OPERATION switch.
- ① Press it once, and after test run for 30 minutes the EMERGENCY COOL MODE starts.
- ② Press it once more, and the operation stops. (The operation mode alternates between ① and ② every time the EMERGENCY OPERATION switch is pressed.)

Mode	Operation Indicator lamp
① COOL	(Light) (Off)
② STOP	(Off) (Off)

**COOL & HEAT MUH type**

- Before performing the test run, recheck for any wrong wiring. Wrong wiring prevents normal operation or results in blown fuse disabling operation.
- The test run can be started by pressing EMERGENCY OPERATION switch. When the EMERGENCY OPERATION switch is once pressed, the unit will start the test run (continuous operation) for 30 minutes. A thermostat does not work during this time. After 30 minutes the unit will start the EMERGENCY OPERATION at a fixed temperature setting of 24°C in COOL MODE or HEAT MODE.
- Perform test run in the following procedure.

**PROCEDURE**

- Press the EMERGENCY OPERATION switch.
- ① Press it once, and after test run for 30 minutes the EMERGENCY COOL MODE starts.

If the left side lamp of the operation indicator blinks every 0.5 seconds, inspect the indoor/outdoor connecting wire Ⓐ for mis-wiring.

- ② Press it once more, and the EMERGENCY HEAT MODE starts.
- ③ Press it once more, and the operation stops. (The operation mode changes in order of ① to ③ every time the EMERGENCY OPERATION switch is pressed.)

Mode	Operation Indicator lamp
① COOL	(Light) (Off)
② HEAT	(Off) (Light)
③ STOP	(Off) (Off)

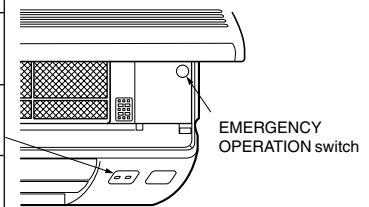

- In starting the heating operation, indoor unit fan may not operate to prevent blowing cool air. Please wait for a few minutes until the temperature of heat exchanger rises and warm air blows out.

**COOL ONLY MU type and COOL & HEAT MUH type**

**Checking the remote (infrared) signal reception**

Press the ON/OFF button on the remote controller and check that an electronic sound is heard from the indoor unit. Press the ON/OFF button again to turn the air conditioner off.

**If the indoor unit is operated with the remote controller, both the test run and the emergency operation are released by commands from the remote controller.**

- Once the compressor stops, the restart preventive device operates so the compressor will not operate for three minutes to protect the air conditioner.

**EXPLANATION TO THE CUSTOMER**

- Using the OPERATING INSTRUCTIONS, explain the following to the customer, how to control temperature, how to remove the air filters, how to remove or put the remote controller in the remote controller mounting hardware, how to clean, precautions for operation, etc.
- Recommend the customer to read the OPERATING INSTRUCTIONS carefully.

MS-C18/C24TV, MSH-C18TV

INSTALLATION DIAGRAM & ACCESSORIES

FLARED CONNECTIONS

- This unit has flared connections on both indoor and outdoor sides.
- Remove the outdoor units valve cover, then connect the pipe.
- Refrigerant pipes are used to connect the indoor and outdoor units.

Limits	
Pipe length	15 max.
Height difference	5 m max.
No. of bends	10 max.

- Refrigerant adjustment ... If pipe length exceeds 7 m, additional refrigerant (R407C) charge is required.  
(The outdoor unit is charged with refrigerant for pipe length up to 7 m.)

Pipe length	Up to 7 m	No additional charge is required.
	Exceeding 7 m	Additional charge is required. (Refer to the table below.)
Refrigerant to be added	MS type	20 g × (refrigerant piping length (m) - 7)
	MSH type	35 g × (refrigerant piping length (m) - 7)

ACCESSORIES

Check the following parts before installation.

<Indoor unit>

1	Installation plate	1
2	Installation plate fixing screw 4 × 25 mm	5
3	Remote controller mounting hardware	1
4	Fixing screw for 3.5 × 16 mm (Black)	2
5	Battery (AAA) for remote controller	2
6	Wireless remote controller	1
7	Felt tape (Used for left or left-rear piping)	1
8	Refrigeration oil	1

<Outdoor unit: MUH type>

9	Drain socket	1
10	Drain cap φ33	2
	Drain cap φ16	1

PART TO BE PROVIDED AT YOUR SITE

Optional extension pipe

A	Indoor/outdoor unit connecting wire 3-core 1.5 mm <sup>2</sup> (MS-C18 type) 4-core 1.5 mm <sup>2</sup> (MSH-C18 type) 4-core 2.5 mm <sup>2</sup> (MS-C24 type)	1
B	Extension pipe	1
C	Wall hole sleeve	1
D	Wall hole cover	1
E	Pipe fixing band (The quantity depends on the pipe length.)	2 to 5
F	Fixing screw for 4 × 20 mm (The quantity depends on the pipe length.)	2 to 5
G	Piping tape	1
H	Putty	1
I	Drain hose (or soft PVC. hose, 15 mm inner dia. or hard PVC pipe VP16)	1

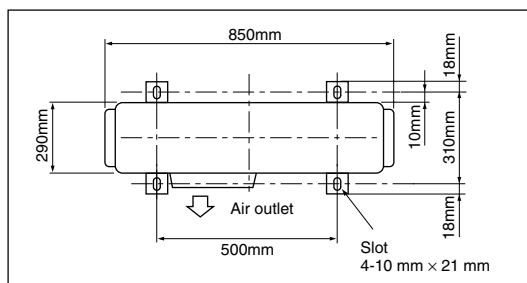

PIPING PREPARATION

- Refrigerant pipes of 3,5,7,10 and 15 m are available as optional items.
- ① Table below shows the specifications of pipes commercially available.

Pipe		Outside diameter	Insulation thickness	Insulation material
		mm	mm	
For liquid	C18 type	6.35	8	Heat resisting foam plastic specific gravity 0.045
	C24 type	9.52	8	
For gas		15.88	8	

- ② Ensure that the 2 refrigerant pipes are insulated to prevent condensation.
- ③ Refrigerant pipe bending radius must be 100 mm or more.

CAUTION

Be sure to use the insulation of specified thickness. Excessive thickness may cause incorrect installation of the indoor unit and lack of thickness may cause dew dripage.

Decide the installation position using mark on the installation plate indicating the indoor unit size as reference.

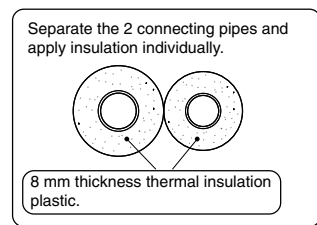
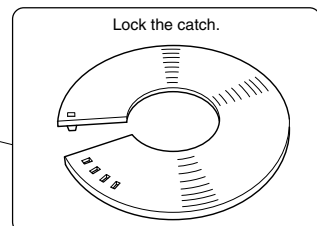
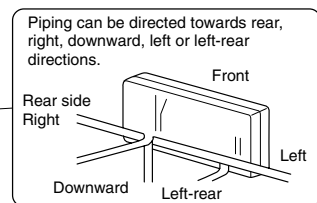
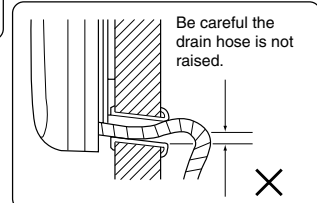
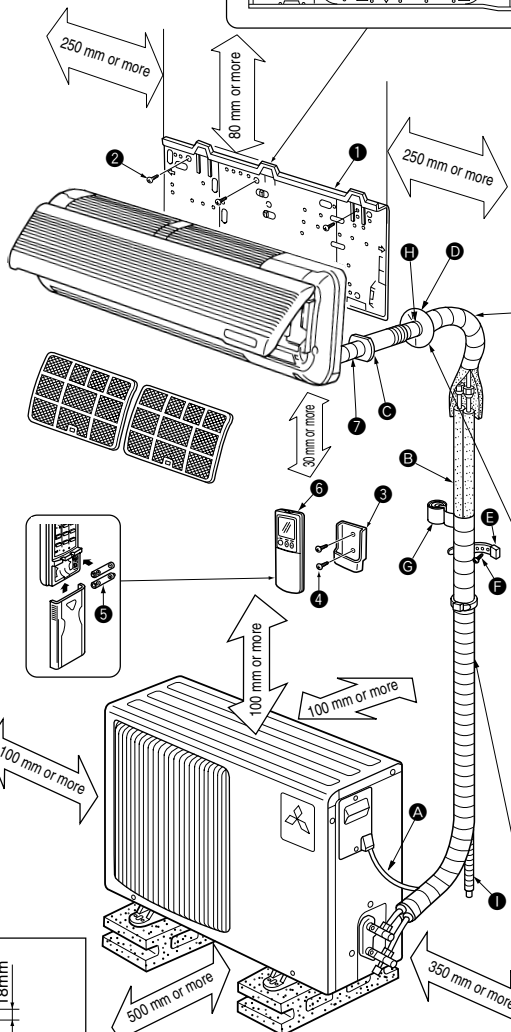
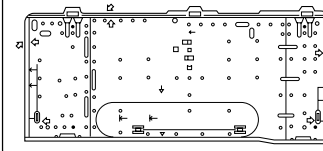

When the piping is to be attached to a wall containing metals (tin plated) or metal netting, use a chemically treated wooden piece 20 mm or thicker between the wall and the piping or wrap 7 to 8 turns of insulation vinyl tape around the piping.

Units should be installed by licensed contractor according to local code requirement.

INSTALLATION PROCEDURE

WALL-MOUNTED

**POWER SUPPLY AND CONNECTING WIRE SPECIFICATIONS**

- Use special room air conditioning circuit.

Power supply cord length (Lead to left/Lead to right)	1 m/2 m	
Indoor and Outdoor connecting wire Specification	MS-C18 type	Cable 3-core 1.5 mm <sup>2</sup> , in conformity with Design 245 IEC 57
	MSH-C18 type	Cable 4-core 1.5 mm <sup>2</sup> , in conformity with Design 245 IEC 57
	MS-C24 type	Cable 4-core 2.5 mm <sup>2</sup> , in conformity with Design 245 IEC 57

- Take out power supply cord from the left or right bottom corner of the indoor unit.

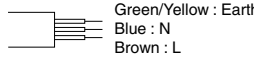
Connect to the plug, or to a power switch which has a gap of 3 mm or more when open to interrupt the source power phase.  
(Input capacity Main switch/Fuse: 15 A (C18 type), 25 A (C24 type))  
(This plug has to be the one meets the Standards.)  
Power supply cord  Green/Yellow : Earth  
Blue : N  
Brown : L

**⚠ WARNING**  
Never cut the power cord and connect to other wires.  
It may cause a fire.

Do not bundle the spare wire, but house it as shown in the figure below.

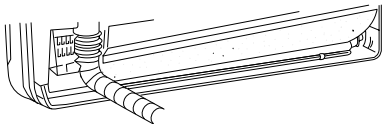

**INDOOR AND OUTDOOR CONNECTING WIRE CONNECTION**

You can connect indoor/outdoor lead wire without removing the front panel.

- ① Pull the right and left end of air intake grille forward to open it.
- ② Remove two screws that fixed electrical cover to open it.
- ③ Pass the indoor/outdoor unit connecting wire from the back of the indoor unit and process the end of the wire, then connect it to the terminal block.
- ④ Replace the electrical part cover securely.

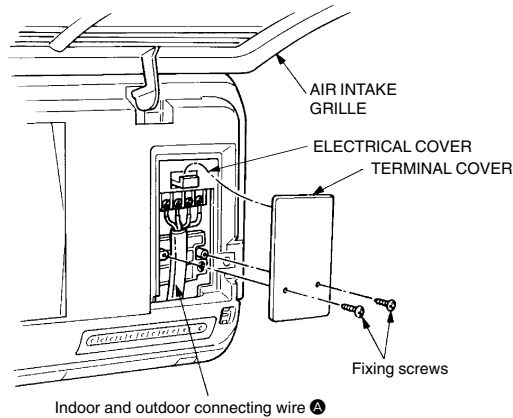

**⚠ WARNING**

- Use the indoor/outdoor unit connecting wire that meets the Standards to connect the indoor and outdoor units and fix the wire to the terminal block securely so that no external force is conveyed to the connecting section of the terminal block. Incomplete connection or fixing of the wire could result in a fire.
- Attach the electrical cover securely. If it is attached incorrectly, it could result in a fire or an electric shock due to dust, water, etc.

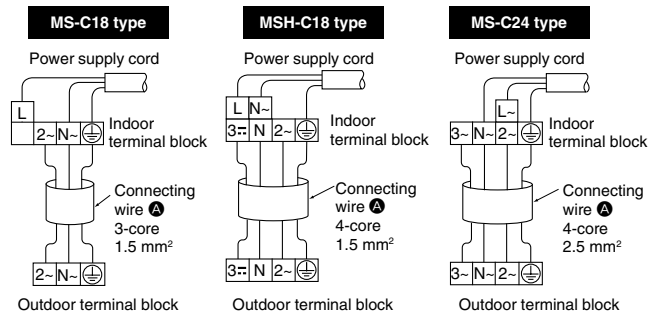
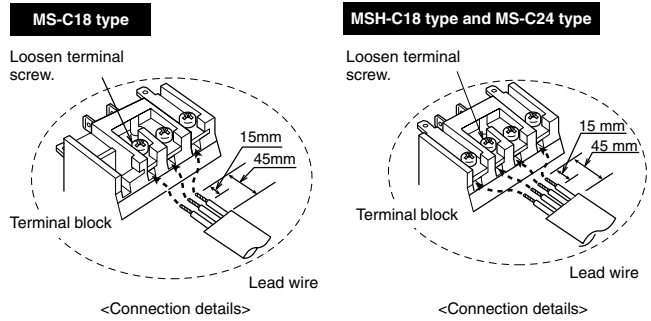

**⚠ CAUTION**

- Be careful not to make mis-wiring.
- Firmly tighten the terminal screws to prevent them from loosening.
- After tightening, pull the wires lightly to confirm that they do not move.
- If the connecting wire is incorrectly connected to the terminal block, the unit does not operate normally.
- If an earth is incorrect, it may cause an electric shock.

**AUTO RESTART FUNCTION**

When the indoor unit is controlled with the remote controller, the operation mode, the set temperature, and the fan speed are memorized by the indoor electronic control P.C. board. The auto restart function sets to work the moment the power has restored after power failure, then, the unit will restart automatically. If the unit is operated in "I FEEL CONTROL" mode before power failure, the operation is not memorized. In "I FEEL CONTROL" mode, the operation is decided by the initial room temperature at (re)start.

**How to set "AUTO RESTART FUNCTION"**

- ① Remove the front panel.
- ② Remove the screws and the terminal cover.  
Remove the electrical cover.
- ③ Remove the screw of terminal block.
- ④ Unhook the catch of the lamp holder.
- ⑤ Remove the receiver holder.
- ⑥ Remove the screw of the earth wire.
- ⑦ Disconnect all the lead wires on the electronic control P.C. board.
- ⑧ Remove the electronic control P.C. board.
- ⑨ Cut the RESISTOR JR06 on the indoor electronic control P.C. board.

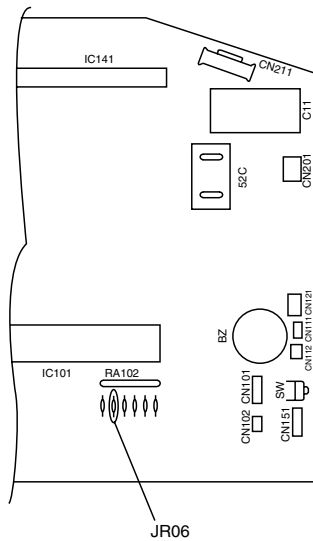

**Operation**

- ① If the main power (230V AC) has been cut, the operation settings remain.
- ② When three minutes have passed after power was restored, the unit will restart automatically according to the memory.

**Notes:**

- The operation settings are memorized when 10 seconds have passed after the remote controller was operated.
- If the main power is turned off or a power failure occurs while AUTO START/STOP timer is active, the timer setting is cancelled. As these models are equipped with the auto restart function, the air conditioner should start operating at the same time that a power has restored.
- If the unit has been off with the remote controller before power failure, the auto restart function does not work as the power button of the remote controller is off.
- To prevent breaker off due to the rush of starting current, systematize other home appliance not to turn on at the same time.

**OUTDOOR UNIT INSTALLATION**

**INDOOR AND OUTDOOR WIRE CONNECTION**

- Connect the indoor/outdoor unit connecting wire **A** from the indoor unit correctly on the terminal block.
- For future servicing, give extra length to connecting wire.

- Peel off both ends of connecting wire as shown in the right.
- Be careful not to contact connecting wire with piping.

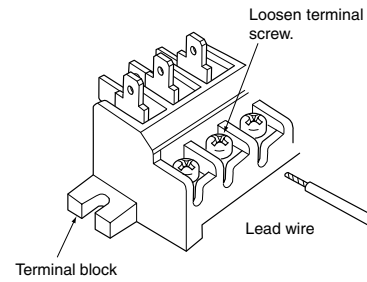

<Connection details>

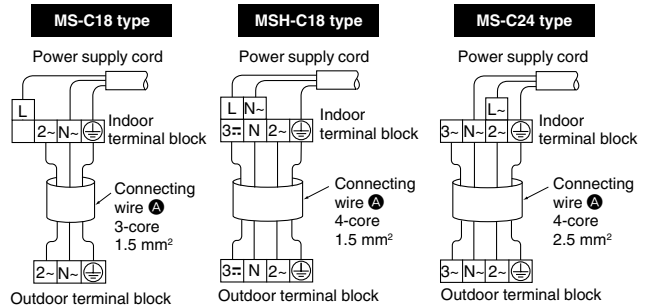

**CAUTION**

- Be careful not to make mis-wiring.
- Firmly tighten the terminal screws to prevent them from loosening.
- After tightening, pull the wires lightly to confirm that they do not move.
- If the connecting wire is incorrectly connected to the terminal block, the unit does not operate normally.

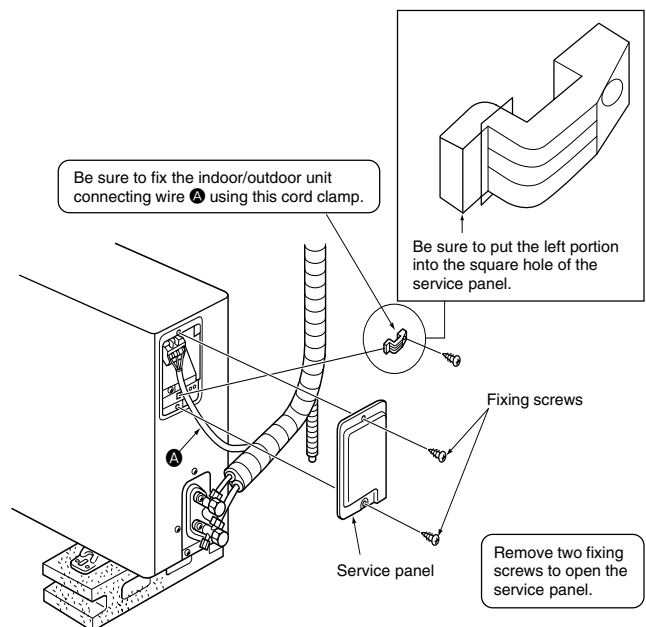

**WARNING**

Be sure to attach the service panel of the outdoor unit securely. If it is not attached correctly, it could result in fire or an electric shock due to dust, water, etc.

**DRAIN PIPING**

- The drain hose should point downward for easy drain flow. (Fig. 1)  
Do not make drain piping as shown in Fig. 2 to 5.

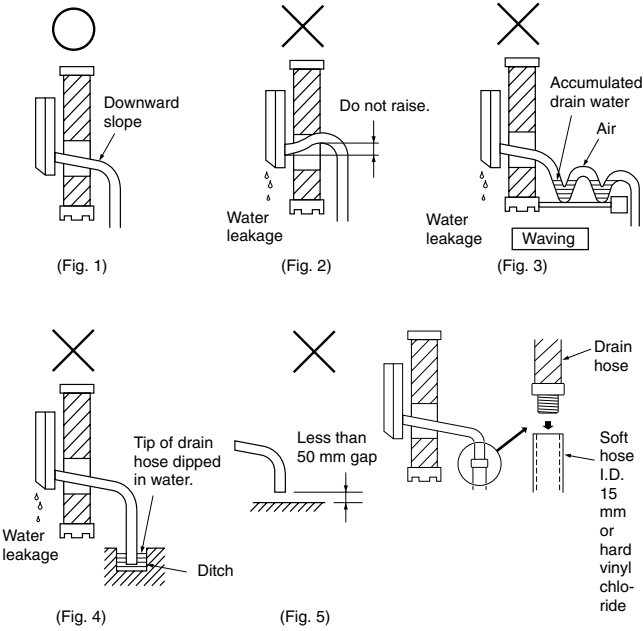

- If the drain hose provided with the indoor unit is too short, connect it with drain hose ● the should be provided at your site.
- If the extension drain hose has to pass through a room, be sure to wrap with commercially sold insulation.

**TEST RUN**

**MS type**

- Before performing the test run, recheck for any wrong wiring. Wrong wiring prevents normal operation or results in blown fuse disabling operation.
- The test run can be started by pressing EMERGENCY OPERATION switch. When the EMERGENCY OPERATION switch is once pressed, the unit will start the test run (continuous operation) for 30 minutes. A thermostat does not work during this time. After 30 minutes the unit will start the EMERGENCY OPERATION at a fixed temperature setting of 24°C in COOL MODE.
- Perform test run in the following procedure.

**PROCEDURE**

- Press the EMERGENCY OPERATION switch.
- Press it once, and after test run for 30 minutes the EMERGENCY COOL MODE starts.
- Press it once more, and the operation stops. (The operation mode alternates between ① and ② every time the EMERGENCY OPERATION switch is pressed.)

	Mode	Operation Indicator lamp	
①	COOL	● (Light)	○ (Off)
②	STOP	○ (Off)	○ (Off)

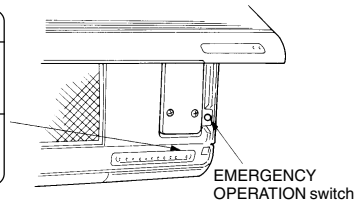

**MSH type**

- Before performing the test run, recheck for any wrong wiring. Wrong wiring prevents normal operation or results in blown fuse disabling operation.
- The test run can be started by pressing EMERGENCY OPERATION switch. When the EMERGENCY OPERATION switch is once pressed, the unit will start the test run (continuous operation) for 30 minutes. A thermostat does not work during this time. After 30 minutes the unit will start the EMERGENCY OPERATION at a fixed temperature setting of 24°C in COOL MODE or HEAT MODE.
- Perform test run in the following procedure.

**PROCEDURE**

- Press the EMERGENCY OPERATION switch.
- Press it once, and after test run for 30 minutes the EMERGENCY COOL MODE starts.

If the left side lamp of the operation indicator blinks every 0.5 seconds, inspect the indoor/outdoor connecting wire Ⓜ for mis-wiring.

- Press it once more, and the EMERGENCY HEAT MODE starts.
- Press it once more, and the operation stops. (The operation mode changes in order of ① to ③ every time the EMERGENCY OPERATION switch is pressed.)

	Mode	Operation Indicator lamp	
①	COOL	● (Light)	○ (Off)
②	HEAT	○ (Off)	● (Light)
③	STOP	○ (Off)	○ (Off)

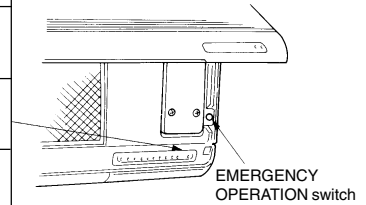

- In starting the heating operation, indoor unit fan may not operate to prevent blowing cool air. Please wait for a few minutes until the temperature of heat exchanger rises and warm air blows out.

**MS type and MSH type**

**Checking the remote (infrared) signal reception**

Press the ON/OFF button on the remote controller and check that an electronic sound is heard from the indoor unit. Press the ON/OFF button again to turn the air conditioner off.

**If the indoor unit is operated with the remote controller, both the test run and the emergency operation are released by commands from the remote controller.**

- Once the compressor stops, the restart preventive device operates so the compressor will not operate for three minutes to protect the air conditioner.

**EXPLANATION TO THE CUSTOMER**

- Using the OPERATING INSTRUCTIONS, explain the following to the customer, how to control temperature, how to remove the air filters, how to remove or put the remote controller in the remote controller mounting hardware, how to clean, precautions for operation, etc.
- Recommend the customer to read the OPERATING INSTRUCTIONS carefully.

INSTALLATION PROCEDURE

WALL-MOUNTED



MSH-C24TV

INSTALLATION DIAGRAM & ACCESSORIES

FLARED CONNECTIONS

- This unit has flared connections on both indoor and outdoor sides.
- Remove the outdoor units valve cover, then connect the pipe.
- Refrigerant pipes are used to connect the indoor and outdoor units.

Limits	
Pipe length	15 m max.
Height difference	5 m max.
No. of bends	10 max.

- Refrigerant adjustment ... If pipe length exceeds 7 m, additional refrigerant (R407C) charge is required.  
(The outdoor unit is charged with refrigerant for pipe length up to 7 m.)

Pipe length	Up to 7 m	No additional charge is required.
	Exceeding 7 m	Additional charge is required. (Refer to the table below.)
Refrigerant to be added	45 g/m × (refrigerant piping length (m) - 7)	

ACCESSORIES

Check the following parts before installation.

<Indoor unit>

1	Installation plate	1
2	Installation plate fixing screw 4 × 25 mm	6
3	Remote controller mounting hardware	1
4	Fixing screw for 3.5 × 16 mm (Black)	2
5	Battery (AAA) for remote controller	2
6	Wireless remote controller	1
7	Felt tape (Used for left or left-rear piping)	1
8	Refrigeration oil	1

<Outdoor unit>

9	Drain socket	1
10	Drain cap	6

PART TO BE PROVIDED AT YOUR SITE

Optional extension pipe

A	Indoor/outdoor unit connecting wire (4-core 2.5 mm <sup>2</sup> or more)	1
B	Extension pipe	1
C	Wall hole sleeve	1
D	Wall hole cover	1
E	Pipe fixing band (The quantity depends on the pipe length.)	2 to 5
F	Fixing screw for 4 × 20 mm (The quantity depends on the pipe length.)	2 to 5
G	Piping tape	1
H	Putty	1
I	Drain hose (or soft PVC hose, 15 mm inner dia. or hard PVC pipe VP16)	1

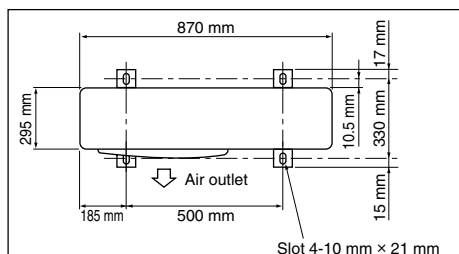

PIPING PREPARATION

- Refrigerant pipes of 3,5,7,10 and 15 m are available as optional items.
- ① Table below shows the specifications of pipes commercially available.

Pipe	Outside diameter	Insulation thickness	Insulation material
	mm	mm	
For liquid	9.52	8	Heat resisting foam plastic specific gravity 0.045
For gas	15.88	8	

- ② Ensure that the 2 refrigerant pipes are insulated to prevent condensation.
- ③ Refrigerant pipe bending radius must be 100 mm or more.

CAUTION

Be sure to use the insulation of specified thickness. Excessive thickness may cause incorrect installation of the indoor unit and lack of thickness may cause dew drippage.

Decide the installation position using mark on the installation plate indicating the indoor unit size as reference.

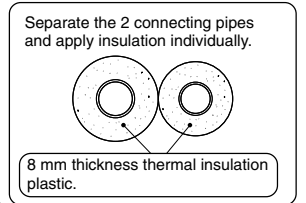
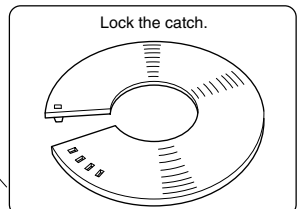
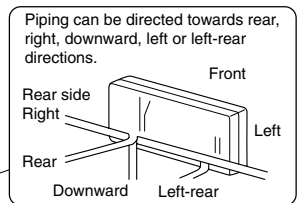
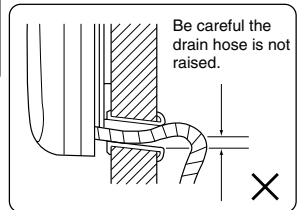
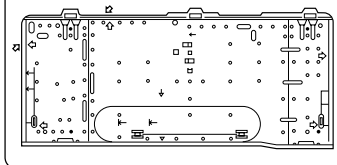

When the piping is to be attached to a wall containing metals (tin plated) or metal netting, use a chemically treated wooden piece 20 mm or thicker between the wall and the piping or wrap 7 to 8 turns of insulation vinyl tape around the piping.

Units should be installed by licensed contractor according to local code requirement.

**FREE SPACE REQUIRED AROUND OUTDOOR UNIT**

① Top side obstacles  
If there are obstacles at the rear side only, other obstacles may be permitted as shown in the diagram of top side.

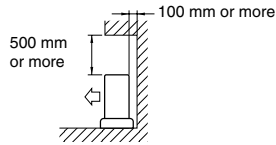

② Front side (blowing side) open  
If only the space shown in diagram can be reserved, obstacles can be allowed in the other 3 directions (but top side open).

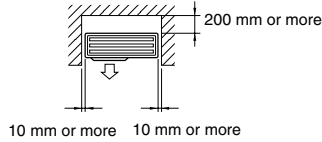

③ Obstacles on front side (blowing side) only  
If there are obstacles on the front side, keep the back, left/right and top sides open.

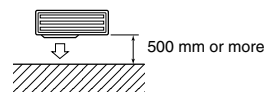

④ Obstacles on front and rear sides  
Unusable in case of the dimensions shown in following diagram. See item ⑤.

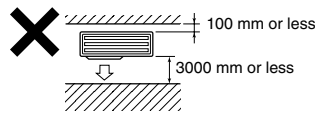

⑤ Obstacles on front and rear sides only  
In this case, fit the outdoor air outlet guide which comes as an option (left/right and top sides open). But if natural wind, like that flowing between buildings, cannot be expected, keep the height or width of obstacles within the following range. Otherwise, there is the risk of short cycle occurring. (If the front or rear side satisfies the requirements, there is no special restriction on the remaining side.)

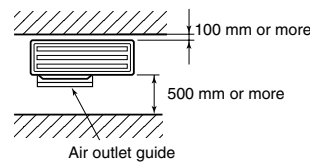

Obstruction width: 1.5 times width of outdoor unit or smaller  
Obstruction height: Unit height or lower

⑥ Obstacles on 4 surrounding sides  
Unusable if there are obstacles on all 4 surrounding sides, even if there is more than the prescribed amount of space around the outdoor unit and even if the top side is open.

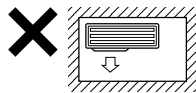

**SERVICE SPACE**

Allow the service space shown in the following diagram to remain open, for maintenance etc. in front of the unit.

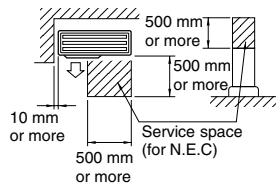

● When installing unit in rooftop or other locations unprotected from wind, situate unit air outlet in direction not directly exposed to strong wind. Strong wind entering air outlet may impede normal air flow and cause malfunctions.

**Examples:**

● Face outlet toward any available wall, 500 mm away from wall.

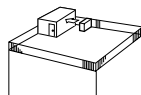

● Install optional air outlet guide, if the unit is installed at a place where the powerful blast of typhoon, etc. come directly on the air outlet.

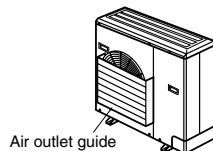

● Position unit so that air outlet blows in direction perpendicular to seasonal wind direction, if known.

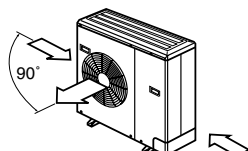

**POWER SUPPLY AND CONNECTING WIRE SPECIFICATIONS**

● Use special room air conditioning circuit.

Power supply cord length (Lead to left/Lead to right)	1 m/2 m
Indoor and Outdoor connecting wire Specification	Cable 4-core 2.5 mm <sup>2</sup> or more, in conformity with Design 245 IEC 57

● Take out power supply cord from the left or right bottom corner of the indoor unit.

Connect to the plug, or to a power switch which has a gap of 3 mm or more when open to interrupt the source power phase. (Input capacity Main switch/Fuse:25 A) (This plug has to be the one meets the Standards.)

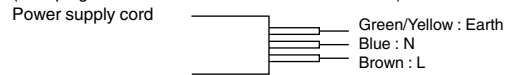

**WARNING**

Never cut the power cord and connect to other wires. It may cause a fire.

Do not bundle the spare wire, but house it as shown in the figure below.

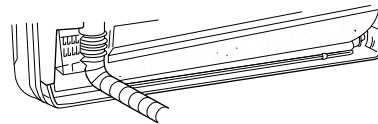

**INDOOR AND OUTDOOR CONNECTING WIRE CONNECTION**

You can connect indoor/outdoor lead wire without removing the front panel.

- ① Pull the right and left end of air intake grille forward to open it.
- ② Remove two screws that fixed electrical cover to open it.
- ③ Pass the indoor/outdoor unit connecting wire from the back of the indoor unit and process the end of the wire, then connect it to the terminal block.
- ④ Replace the fixture and electrical cover securely.

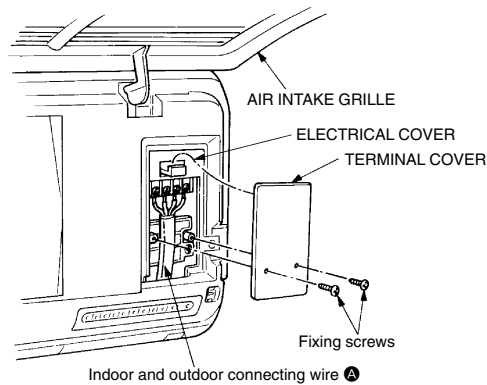

**WARNING**

- Use the indoor/outdoor unit connecting wire that meets the Standards to connect the indoor and outdoor units and fix the wire to the terminal block securely so that no external force is conveyed to the connecting section of the terminal block. Incomplete connection or fixing of the wire could result in a fire.
- Attach the electrical cover securely. If it is attached incorrectly, it could result in a fire or an electric shock due to dust, water, etc.

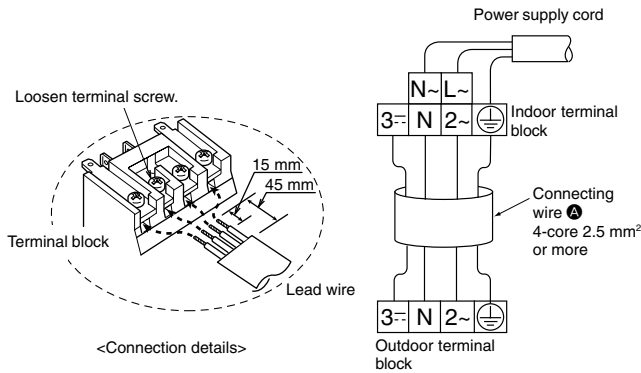

- CAUTION**
- Be careful not to make mis-wiring.
  - Firmly tighten the terminal screws to prevent them from loosening.
  - After tightening, pull the wires lightly to confirm that they do not move.
  - If the connecting wire is incorrectly connected to the terminal block, the unit does not operate normally.
  - If an earth is incorrect, it may cause an electric shock.

**AUTO RESTART FUNCTION**

When the indoor unit is controlled with the remote controller, the operation mode, the set temperature, and the fan speed are memorized by the indoor electronic control P.C. board. The auto restart function sets to work the moment the power has restored after power failure, then, the unit will restart automatically. If the unit is operated in "I FEEL CONTROL" mode before power failure, the operation is not memorized. In "I FEEL CONTROL" mode, the operation is decided by the initial room temperature at (re)start.

**How to set "AUTO RESTART FUNCTION"**

- 1 Remove the front panel.
- 2 Remove the screws and the terminal cover. Remove the electrical cover.
- 3 Remove the screw of terminal block.
- 4 Unhook the catch of the lamp holder.
- 5 Remove the receiver holder.
- 6 Remove the screw of the earth wire.
- 7 Disconnect all the lead wires on the electronic control P.C. board.
- 8 Remove the electronic control P.C. board.
- 9 Cut the RESISTOR JR 06 on the indoor electronic control P.C. board.

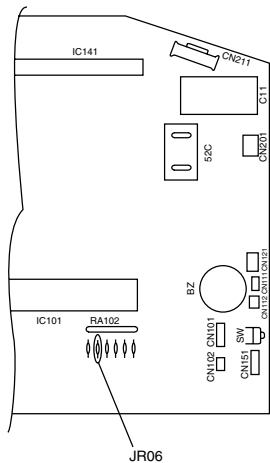

**Operation**

- 1 If the main power (230V AC) has been cut, the operation settings remain.
- 2 When three minutes have passed after power was restored, the unit will restart automatically according to the memory.

**Notes:**

- The operation settings are memorized when 10 seconds have passed after the remote controller was operated.
- If the main power is turned off or a power failure occurs while AUTO START/ STOP timer is active, the timer setting is cancelled. As this model is equipped with the auto restart function, the air conditioner should start operating at the same time that a power has restored.
- If the unit has been off with the remote controller before power failure, the auto restart function does not work as the power button of the remote controller is off.
- To prevent breaker off due to the rush of starting current, systematize other home appliances not to turn on at the same time.

**OUTDOOR UNIT INSTALLATION**

**INSTALLING THE OUTDOOR UNIT**

- CAUTION**
- It is best to transport the unit in its original packaging to the installation site.
  - Since the centre of gravity of the unit is off-centre, caution is necessary when lifting the unit using a rope, etc.
  - The outdoor unit should not be tilted by more than 45° when transporting. (Do not stock them sideways.)

**Prepare the concrete foundation**

Always anchor outdoor unit legs by means of bolts. (Procure anchor bolts locally.) Secure firmly to prevent overturning by earthquakes or gusts of wind. Keep the length of foundation bolts up to 25 mm from the bottom side of installation base.

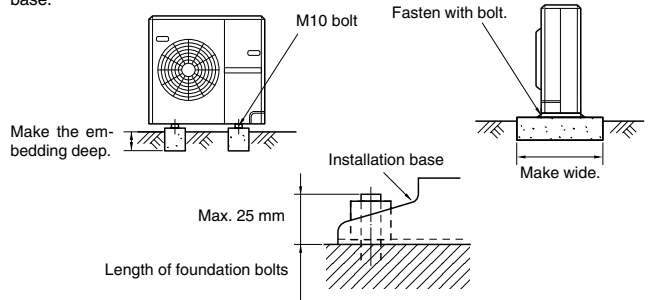

**INSTALLING THE REFRIGERANT TUBING**

- 1 Pipe take-in direction  
The pipe can be passed in any of the four directions: front, rear, right and lower side.

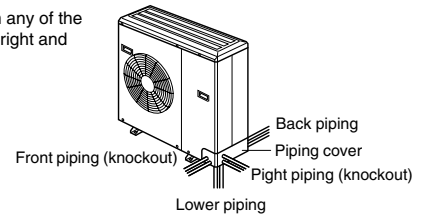

- 2 Remove the service panel (two screws) and the piping cover (two screws).
- Be careful not to break the bent portion when connecting the pipes. Be sure to use two spanners to tighten the flare nuts.

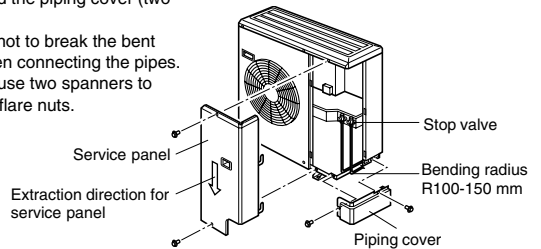

- 3 When racking the pipes, keep the racking below the top of the piping cover to allow easy service panel removal.

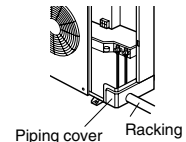

**Note:**

When connecting the pipe, use 2 spanners (wrenches) in servicing as shown in the figure below;

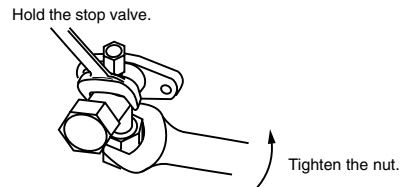

**INDOOR/OUTDOOR WIRE CONNECTION**

- Connect the indoor/outdoor unit connecting wire **A** from the indoor unit correctly on the terminal block.
- For future servicing, give extra length to connecting wire.

- Peel off both ends of connecting wire as shown in the right.
- Be careful not to contact connecting wire with piping.

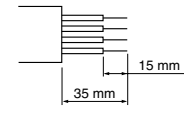

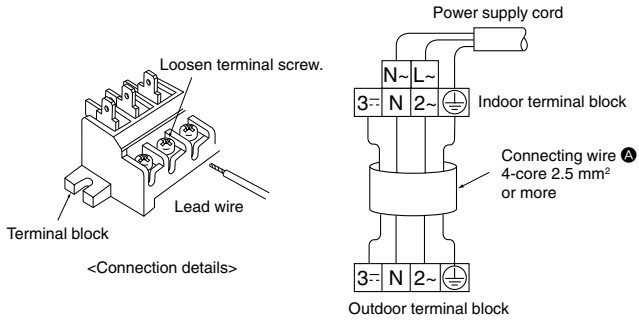

**CAUTION**

- Be careful not to make mis-wiring.
- Firmly tighten the terminal screws to prevent them from loosening.
- After tightening, pull the wires lightly to confirm that they do not move.
- If the connecting wire is incorrectly connected to the terminal block, the unit does not operate normally.

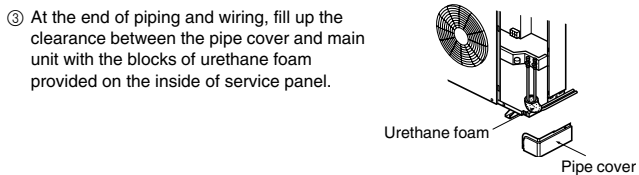
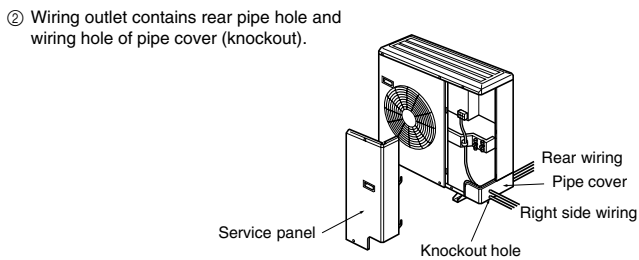
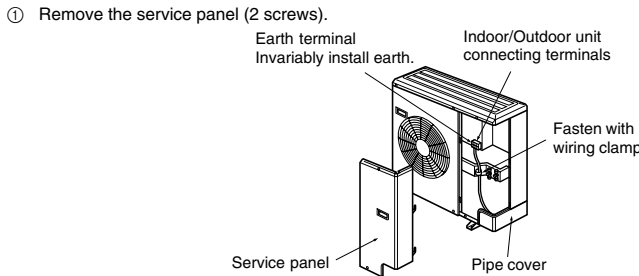

**WARNING**

- Be sure to attach the service panel of the outdoor unit securely. If it is not attached correctly, it could result in a fire or an electric shock due to dust, water, etc.
- Tighten terminal screws securely.

**CAUTION**

- Wiring should be done so that the power lines are not subject to tension. Otherwise, heat may be generated or fire may occur.

**DRAIN PIPING**

- The drain hose should point downward for easy drain flow. (Fig. 1)  
Do not make drain piping as shown in Fig. 2 to 5.

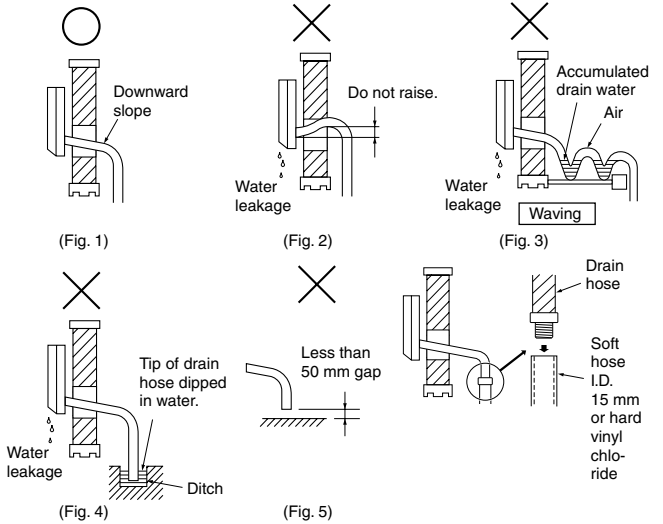

- If the drain hose provided with the indoor unit is too short, connect with drain hose **1** in the part to be provided at your site.
- If the extension drain hose has to pass through a room, be sure to wrap with commercially sold insulation.

**TEST RUN**







- Before performing the test run, recheck for any wrong wiring. Wrong wiring prevents normal operation or results in blown fuse disabling operation.
- The test run can be initiated by using EMERGENCY OPERATION switch (press button switch). The EMERGENCY OPERATION switch is pressed, the unit starts continuous operation and operate for 30 minutes in COOL MODE or HEAT MODE. Depending on which mode is selected. A thermostat does not work during this 30 minutes. After 30 minutes, the unit starts the emergency run at fixed temperature setting of 24°C in COOL MODE or HEAT MODE.
- Perform test run in the following procedure.

**PROCEDURE**

- Press the EMERGENCY OPERATION switch.
- ① Press it once, and after test run for 30 minutes the EMERGENCY OPERATION COOL MODE starts.

If the left side lamp of the operation indicator blinks every 0.5 seconds, inspect the indoor/outdoor connecting wire ⚡ for mis-wiring.

- ② Press it once more, and the EMERGENCY HEAT MODE starts.
- ③ Press it once more, and the operation stops.  
(The operation mode changes in order of ① to ③ every time the EMERGENCY OPERATION switch is pressed.)

	Mode	Operation Indicator lamp	
①	COOL	 (Light)	 (Off)
②	HEAT	 (Off)	 (Light)
③	STOP	 (Off)	 (Off)

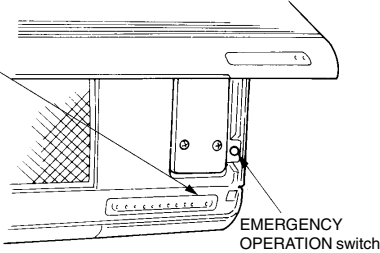

**Checking the remote (infrared) signal reception**

Press the ON/OFF button on the remote controller and check that an electronic sound is heard from the indoor unit. Press the ON/OFF button again to turn the air conditioner off.

**If the indoor unit is operated with the remote controller, both the test run and the emergency operation are released by commands from the remote controller.**

- Once the compressor stops, the restart preventive device operates so the compressor will not operate for three minutes to protect the air conditioner.

**EXPLANATION TO THE CUSTOMER**

- Using the OPERATING INSTRUCTIONS, explain the following to the customer, how to control temperature, how to remove the air filters, how to remove or put the remote controller in the remote controller mounting hardware, how to clean, precautions for operation, etc.
- Recommend the customer to read the OPERATING INSTRUCTIONS carefully.

## B.1.11 MICROPROCESSOR CONTROL

### B.1.11.1 MSC Series

**MSC-C07TV, MU-C07TV, MUH-C07TV**  
**MSC-C09TV, MU-C09TV, MUH-C09TV**  
**MSC-C12TV, MU-C12TV, MUH-C12TV**

Once the operation mode are set, the same operation mode can be repeated by simply turning the OPERATE/STOP (ON/OFF) button ON. Indoor unit receives the signal with a beep tone.

When the system turns off, 3-minute time delay will operate to protect system from overload and compressor will not restart for 3 minutes.

### WIRELESS REMOTE CONTROLLER

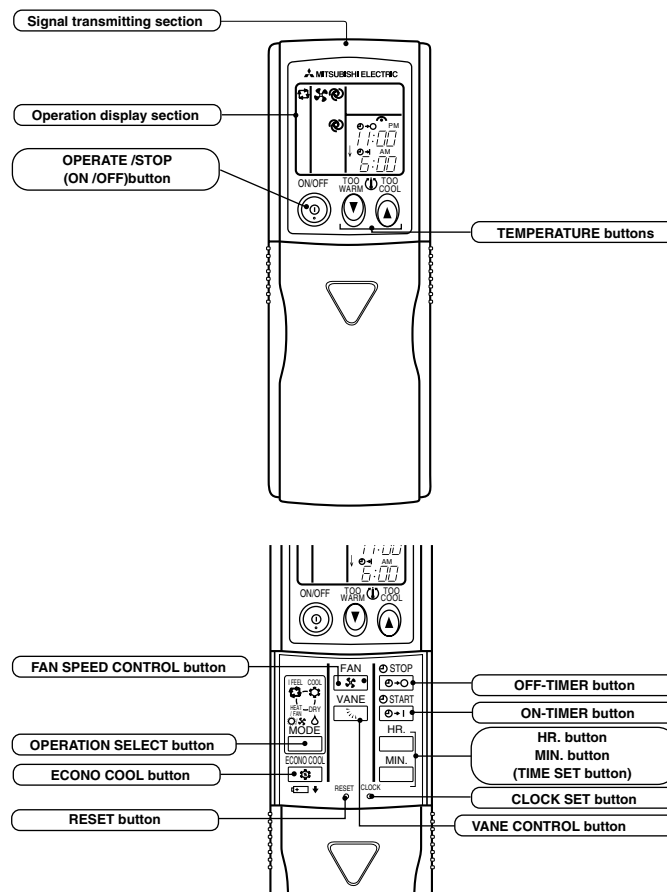

### INDOOR UNIT DISPLAY SECTION

#### Operation indicator lamp

The operation indicator at the right side of the indoor unit indicates the operation state.

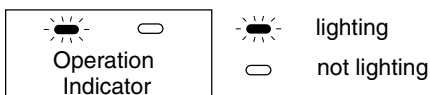

Indication	Operation state	Difference between target temperature and room temperature
	This shows that the air conditioner is operating to reach the target temperature. Please wait until the target temperature is obtained.	Approx. 2 °C or more
	This shows that the room temperature is approaching the target temperature.	Approx. 2 °C or less

**a. COOL (❄️) OPERATION**

- (1) Press OPERATE/STOP(ON/OFF) button. OPERATION INDICATOR lamp of the indoor unit turns on with a beep tone.
- (2) Select COOL mode with the OPERATION SELECT button.
- (3) Press TEMPERATURE buttons (TOO WARM or TOO COOL button) to select the desired temperature.  
The setting range is 16 ~ 31°C

**a.1 Indoor fan speed control**

Indoor fan operates continuously at the set speed by FAN SPEED CONTROL button regardless of thermostat's OFF-ON.  
In Auto the fan speed is as follows.

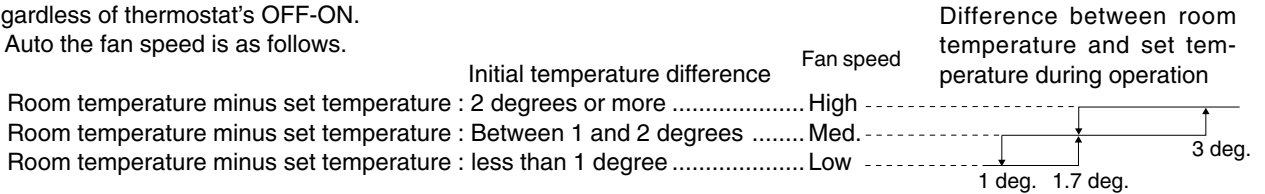

**a.2 Coil frost prevention**

① Temperature control

When the indoor coil thermistor RT12 reads 4°C or below (MSC-C07/C09TV) / 0°C or below (MSC-C12TV) for 5 minutes, the coil frost prevention mode starts.

The indoor fan operates at the set speed and the compressor stops for 5 minutes.

After that, if RT12 still reads below 4°C (MSC-C07/C09TV) / 0°C (MSC-C12TV), this mode is prolonged until the RT12 reads over 4°C (MSC-C07/C09TV) / 0°C (MSC-C12TV).

② Time control

When the three conditions as follows have been satisfied for 1 hour and 45 minutes, the compressor stops for 3 minutes. The indoor fan operates at the set speed.

- a. Compressor has been continuously operating.
- b. Indoor fan speed is Low or Med..
- c. Room temperature is below 26°C.

When compressor stops, the accumulated time is cancelled. When compressor restarts, time counting starts from the beginning.

Time counting also stops temporarily when the indoor fan speed becomes High or the room temperature exceeds 26°C. However, when two of the above conditions (b.and c.) are satisfied again, time accumulation is resumed.

**Operation chart**

**Example**

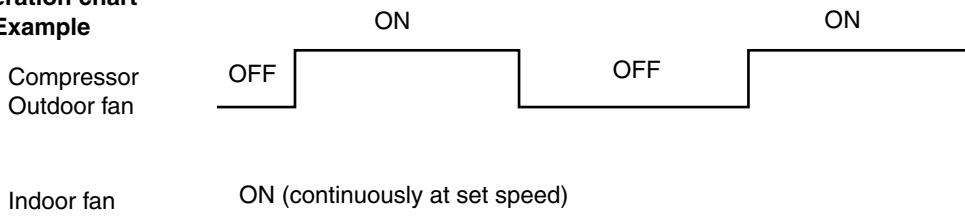

**b. DRY (☀️) OPERATION**

- (1) Press OPERATE/STOP (ON/OFF) button. OPERATION INDICATOR lamp of the indoor unit turns on with a beep tone.
- (2) Select DRY mode with the OPERATION SELECT button.
- (3) The microprocessor reads the room temperature and determines the set temperature. Set temperature is as shown on the right chart.  
DRY operation will not function when the room temperature is 13°C or below.

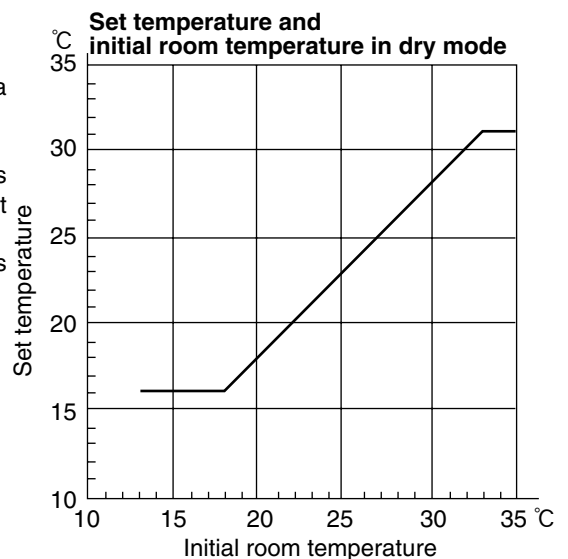

The system for dry operation uses the same refrigerant circuit as the cooling circuit.

The compressor and the indoor fan are controlled by the room temperature.

By such controls, indoor flow amounts will be reduced in order to lower humidity without much room temperature decrease.

**b.1 Indoor fan speed control**

Indoor fan operates at the set speed by FAN SPEED CONTROL button.

In Auto fan speed becomes Low.

**b.2 The operation of the compressor and indoor / outdoor fan**

Compressor operates by room temperature control and time control.

Indoor fan and outdoor fan operate in the same cycle as the compressor.

- When the room temperature is 23°C or over:
  - When the thermostat is ON, the compressor repeats 8 minutes ON and 3 minutes OFF.
  - When the thermostat is OFF, the compressor repeats 4 minutes OFF and 1 minute ON.
- When the room temperature is under 23°C.
  - When the thermostat is ON, the compressor repeats 2 minutes ON and 3 minutes OFF.
  - When the thermostat is OFF, the compressor repeats 4 minutes OFF and 1 minute ON.

**Operation time chart**

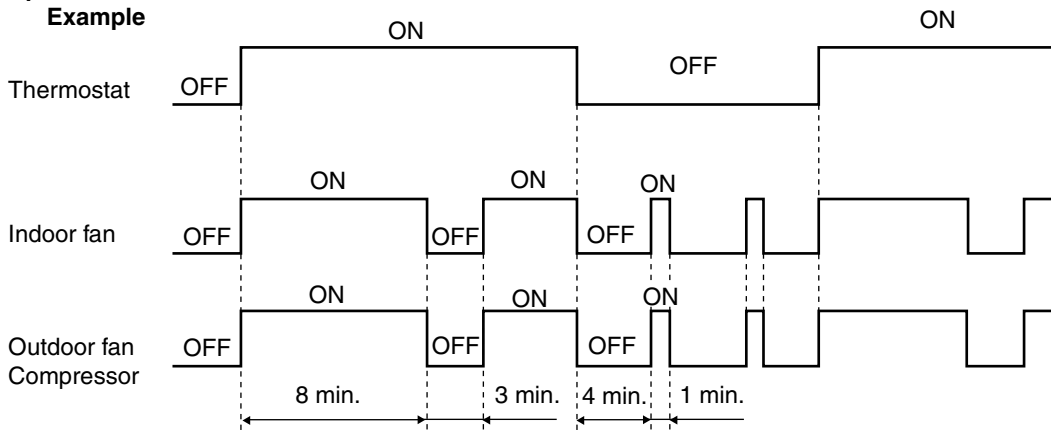

**b.3 Coil frost prevention**

The operation is as same as coil frost prevention during COOL operation. (Refer to a.2 Coil frost prevention) However when coil frost prevention works while the indoor fan is OFF, it's speed becomes set speed.

**c. FAN (🌀) OPERATION <MU-C07/C09/C12TV>**

- (1) Press OPERATE/STOP (ON/OFF) button. OPERATION INDICATOR lamp of the indoor unit turns on with a beep tone.
- (2) Select FAN mode with the OPERATION SELECT button.
- (3) Select the desired fan speed. When AUTO, it becomes Low.
  - Only indoor fan operates.
  - Outdoor unit does not operate.

**d. HEAT (☀️) OPERATION <MUH-C07/C09/C12TV>**

- (1) Press OPERATE/STOP (ON/OFF) button. OPERATION INDICATOR lamp of the indoor unit turns on with a beep tone.
- (2) Select HEAT mode with the OPERATION SELECT button.
- (3) Press TEMPERATURE buttons (TOO WARM or TOO COOL button) to select the desired temperature. The setting range is 16 ~ 31°C.

**d.1 Indoor fan speed control**

- (1) Indoor fan operates at the set speed by FAN SPEED CONTROL button. In Auto the fan speed is as follows.

Initial temperature difference	Fan speed
Set temperature minus room temperature: 2 degrees or more .....	High
Set temperature minus room temperature: Between 1 and 2 degrees .....	Med.
Set temperature minus room temperature: less than 1 degree .....	Low

Difference between room temperature and set temperature during operation

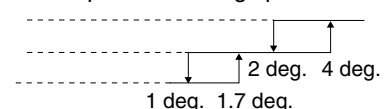



(2) Cold air prevention control

- ① When the compressor is not operating,
  - ( I ) if the temperature of indoor coil thermistor RT12 is 18°C or less, the fan stops.
  - ( II ) if the temperature of indoor coil thermistor RT12 is more than 18°C, the fan operates at Very Low.
- ② When the compressor is operating,
  - ( I ) if the temperature of RT12 is 22°C or more, the fan operates at set speed.
  - ( II ) if the temperature of RT12 is less than 22°C and
    - ( i ) if the temperature of room temperature thermistor RT11 is 15°C or less, the fan stops.
    - ( ii ) if the temperature of room temperature thermistor RT11 is more than 15°C, the fan operates at Very Low.

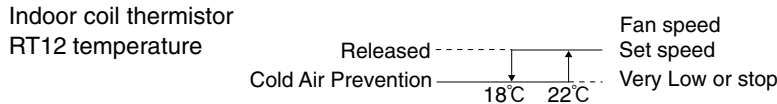

**NOTE:** If the temperature of RT12 reads from 18°C to 22°C at the air conditioner starting and also after defrosting, this control works.

(3) Warm air control.

When the following any condition of ① (a. ~ d.) and the condition of ② are satisfied at the same time, warm air control works.

- ① a.) when the operation mode has been changed to HEAT mode
- b.) when cold air prevention has been released
- c.) when defrosting has been finished
- d.) when the compressor starts in HEAT mode
- ② When the temperature of indoor coil thermistor RT12 is less than 37°C.

When warm air control works, the fan speed changes as follows to blow out warm air gradually.

**Gradation of fan speed in initial**

<Time condition>	<Indoor fan speed>
less than 2 minutes	Low
2 minutes to 4 minutes	Med.
more than 4 minutes	High

The upper limit of the fan speed in MANUAL is the set speed.

The upper limit of the fan speed in AUTO is the speed decided by indoor fan speed control.

(Refer to d.1 Indoor fan speed control (1).)

When the temperature of RT12 has been 37°C or more, or when the set speed has been changed, this control is released and the fan speed is the set speed.

(4) Flow soft control

When the thermostat (compressor) is off, the indoor fan operates as follows.

RT12	fan
less than 18°C	off
18°C or more	Very Low

**NOTE:** When the thermostat (compressor) turns on, the fan will operate at set speed. But until cold air prevention and warm air control is released, the fan speed follow them.

**d.2 High pressure protection**

During heating operation, the outdoor fan motor is controlled by the temperature of indoor coil thermistor RT12 for excess rise protection of compressor discharge pressure.

- Outdoor fan OFF: 52°C (MUH-C07/C09TV)  
                  56°C (MUH-C12TV)
- Outdoor fan ON: 48°C (MUH-C07/C09TV)  
                  52°C (MUH-C12TV)

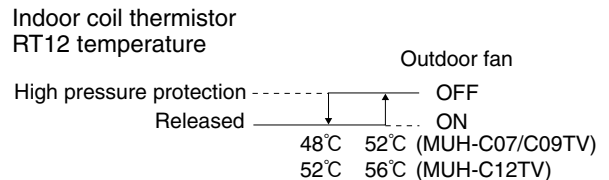

**Operation chart**

**Example**

Indoor coil thermistor

RT12 temperature

(MUH-C07/C09TV)52°C  
(MUH-C12TV)56°C

(MUH-C07/C09TV)48°C  
(MUH-C12TV)52°C

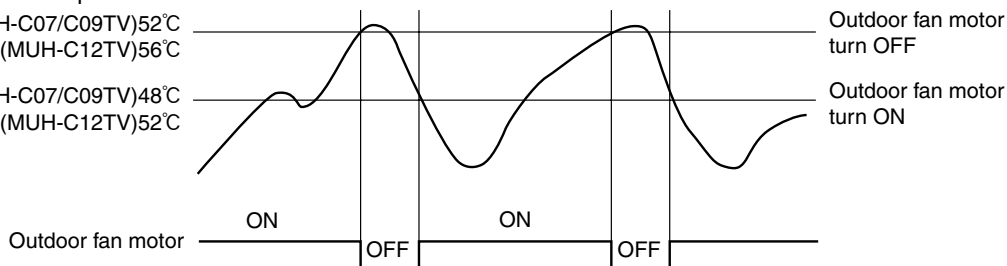

**NOTE:** During high pressure protection and for 4 min. and 15 sec. after high pressure protection, defrosting of outdoor heat exchanger is not detected by the defrost thermistor RT61. (Refer to d.3. Defrosting)

**d.3 Defrosting**

Defrosting of outdoor heat exchanger is controlled by DEICER P.C. board, with detection by the defrost thermistor RT61.

(1) Starting conditions of defrost

When all conditions of a) ~ c) are satisfied, the defrosting operation starts.

a) The compressor cumulative operation time exceeds 40 minutes without the defrosting operation working.

b) RT61 reads - 4.6°C (MUH-C07TV)/ - 2.7°C (MUH-C09/C12TV) or less.

c) After releasing the high pressure protection 4 minutes and 15 seconds have elapsed.

(2) Releasing conditions of defrost

When the condition d) or e) is satisfied, the defrosting operation stops.

d) RT61 reads 12.8°C (MUH-C07TV)/ 16.3°C (MUH-C09/C12TV) or more.

e) The defrosting time exceeds 10 minutes.

**Operation time chart**

**Example**

Defrost thermistor RT61

12.8°C (MUH-C07TV) or more

16.3°C (MUH-C09/C12TV) or more

- 4.6°C (MUH-C07TV) or less

- 2.7°C (MUH-C09/C12TV) or less

Outdoor 52C  
contactor  
(Compressor)

ON

OFF

X62  
(R.V.coil)

ON

OFF

SR61  
Outdoor fan

ON

OFF

Defrost  
counter

ON

OFF

Indoor fan

ON

Very Low

OFF

Indoor  
Horizontal vane

Horizontal

Set position

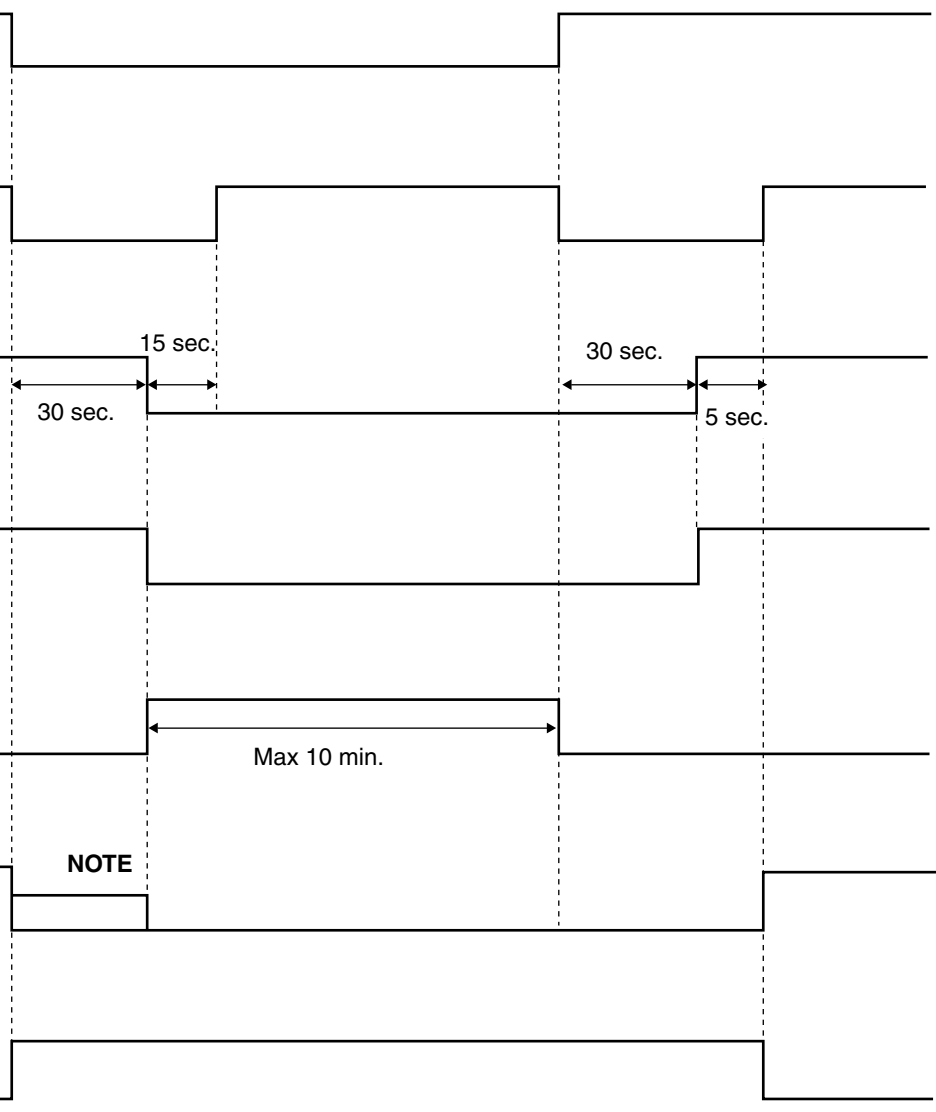

- NOTE:**
- When the indoor coil thermistor RT12 reads above 18°C, indoor fan operates at Very Low for 30 seconds.
  - When the indoor coil thermistor RT12 reads 18°C or less, the indoor fan stops.

**d.4 R.V. coil control**

- Heating ..... ON
- Cooling ..... OFF
- Dry ..... OFF

**NOTE:** When operation starts, the 4-way valve reverses for 5 seconds right before start-up of the compressor.

**Operation time chart**

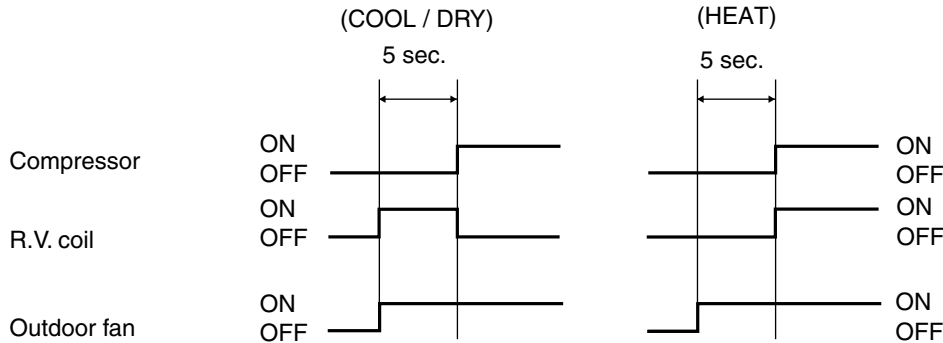

**e. "I FEEL CONTROL" (□) OPERATION**

- (1) Press OPERATE/STOP (ON/OFF) button on the remote controller. OPERATION INDICATOR lamp of the indoor unit turns on with a beep tone.
- (2) Select "I FEEL CONTROL" (□) mode with the OPERATION SELECT button.
- (3) The operation mode is determined by the initial room temperature at start-up of the operation, as shown on the right table.

Initial room temperature		Mode
MU type	MUH type	
25°C or more	25°C or more	COOL mode of "I FEEL CONTROL"
more than 13°C, less than 25°C	23°C or more, less than 25°C	DRY mode of "I FEEL CONTROL"
—	less than 23°C	HEAT mode of "I FEEL CONTROL"

- Once the mode is fixed, the mode does not change by room temperature afterwards.
- Under the ON-TIMER (⊖→|) operation, mode is determined according to the room temperature at set time the operation starts.
- When the system is stopped on the remote controller and restarted within 2 hours in "I FEEL CONTROL" (□) mode, the system operates in previous mode automatically regardless of the room temperature.

**Operation time chart**

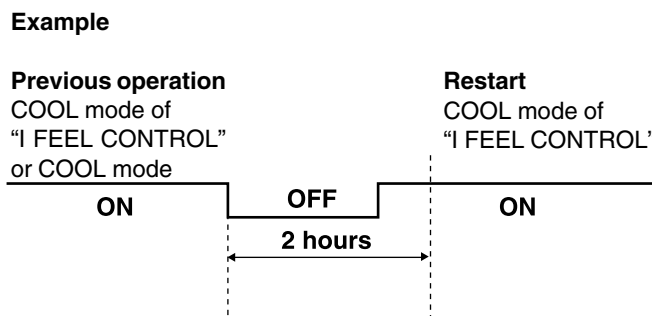

When the system is restarted after 2 hours and more, the operation mode is determined by the room temperature at start-up of the operation.

**Operation time chart**

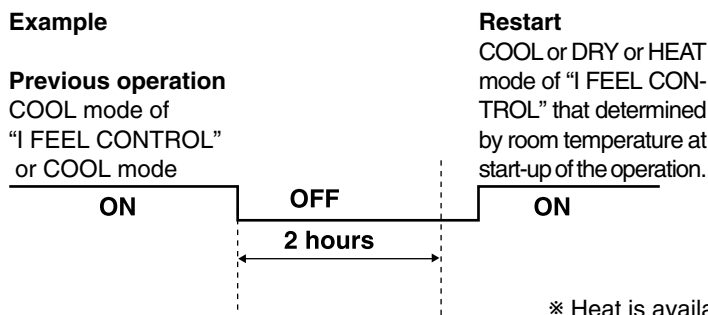

\* Heat is available only in MUH-C07/C09/C12TV.

(4) The initial set temperature is decided by the initial room temperature.

Mode	Initial room temperature		Initial set temperature	
	MU type	MUH type		
COOL mode of "I FEEL CONTROL"	26°C or more	26°C or more	24°C	※1
	25°C to 26°C	25°C to 26°C	Initial room temperature minus 2°C	
DRY mode of "I FEEL CONTROL"	more than 13°C, less than 25°C	23°C to 25°C	Initial room temperature minus 2°C	
HEAT mode of "I FEEL CONTROL"	—	less than 23°C	26°C	

※1 When the system is restarted with the remote controller, the system operates with the previous set temperature regardless of the room temperature at restart.  
The set temperature is calculated by the previous set temperature.

(5) TEMPERATURE buttons

In "I FEEL CONTROL" (□) mode, set temperature is decided by the microprocessor based on the room temperature. In addition, set temperature can be controlled by TOO WARM or TOO COOL buttons when you feel too cool or too warm. Each time the TOO WARM or TOO COOL button is pressed, the indoor unit receives the signal and emits a beep tone.

● Fuzzy control

When the TOO COOL or TOO WARM button is pressed, the microprocessor changes the set temperature, considering the room temperature, the frequency of pressing TOO COOL or TOO WARM button and the user's preference to heat or cool. So this is called "Fuzzy control", and works only in "I FEEL CONTROL" mode.  
In DRY mode of "I FEEL CONTROL", the set temperature doesn't change.



... To raise the set temperature 1~2 degrees(°C)



... To lower the set temperature 1~2 degrees(°C)

— COOL mode of "I FEEL CONTROL" —

1. Indoor fan speed control

Indoor fan speed control is as same as COOL OPERATION. (a.1 Indoor fan speed control)

2. Coil frost prevention

Coil frost prevention is as same as COOL OPERATION. (a.2 Coil frost prevention)

— DRY mode of "I FEEL CONTROL" —

1. Indoor fan speed control

Indoor fan speed control is as same as DRY OPERATION. (b.1 Indoor fan speed control)

2. The operation of the compressor and indoor/outdoor fan

The operation of the compressor and indoor/outdoor fan is as same as DRY OPERATION.  
(b.2 The operation of the compressor and indoor/outdoor fan)

3. Coil frost prevention

Coil frost prevention is as same as DRY OPERATION. (b.3 Coil frost prevention)

— HEAT mode of "I FEEL CONTROL" — <MUH-C07/C09/C12TV>

1. Indoor fan speed control

Indoor fan speed control is as same as HEAT OPERATION. (d.1 Indoor fan speed control)

2. High pressure protection

High pressure protection is as same as HEAT OPERATION. (d.2 High pressure protection)

3. Defrosting

Defrosting is as same as HEAT OPERATION. (d.3 Defrosting)

4. R.V. coil control

R.V. coil control is as same as HEAT OPERATION. (d.4 R.V. coil control)

**f. FAN MOTOR CONTROL**

(1) Rotational frequency feedback control

The indoor fan motor is equipped with a rotational frequency sensor, and outputs signal to the microprocessor to feedback the rotational frequency. Comparing the current rotational frequency with the target rotational frequency (High,Med.,Low), the microprocessor controls SR141 and adjusts fan motor electric current to make the current rotational frequency close to the target rotational frequency. With this control, when the fan speed is switched, the rotational frequency changes smoothly.

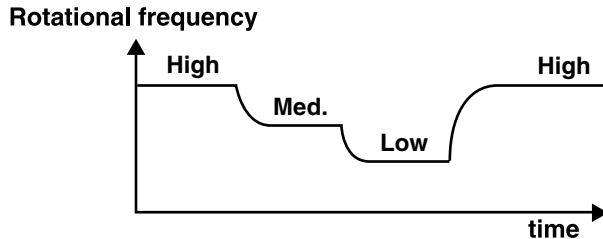

(2) Fan motor lock-up protection

When the rotational frequency feedback signal is not output for 12 seconds, (or when the microprocessor cannot detect the signal for 12 seconds) the fan motor is regarded locked-up. Then the electric current to the fan motor is shut off. 3 minutes later, the electric current is applied to the fan motor again. During the fan motor lock-up, the OPERATION INDICATOR lamp flashes on and off to show the fan motor abnormality.

**g. AUTO VANE OPERATION**

(1) Vane motor drive

These models are equipped with a stepping motor for the horizontal vane. The rotating direction, speed, and angle of the motor are controlled by pulse signals (approx. 12V) transmitted from indoor microprocessor.

(2) The horizontal vane angle and mode changes as follows by pressing the VANE CONTROL button.

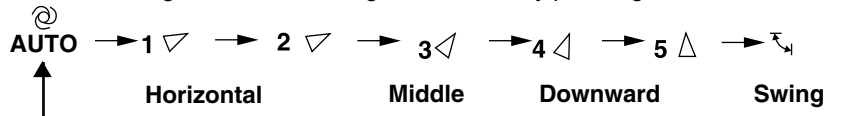

(3) Positioning

The vane is once pressed to the vane stopper below to confirm the standard position and then set to the desired angle. Confirming of standard position is performed in case of follows.

- (a) When the OPERATE/STOP (ON/OFF) button is pressed (Power ON/OFF).
- (b) When the vane control is changed from AUTO to MANUAL.
- (c) When the SWING is finished.
- (d) When the test run starts.
- (e) When the power supply turns ON.

(4) VANE AUTO (@) mode

In VANE AUTO mode, the microprocessor automatically determines the vane angle and operation to make the optimum room-temperature distribution.

① In COOL and DRY operation

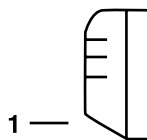

Vane angle is fixed to Angle 1.

② In FAN operation <MU-C07/C09/C12TV>

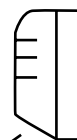

Vane angle is fixed to Angle 4.

② In HEAT operation <MUH-C07/C09/C12TV>

(5) STOP (operation OFF) and ON-TIMER standby.

When the following cases occur, the vane returns to the closed position.

- (a) When the OPERATE/STOP (ON/OFF) button is pressed (POWER OFF).
- (b) When the operation is stopped by the emergency operation.
- (c) When the ON-TIMER is on standby.

- (6) Dew prevention  
During COOL or DRY operation at Vane Angle 4 or 5 when the cumulative operation time of compressor exceeds 1 hour, the vane angle automatically changes to Angle 1 for dew prevention.
- (7) SWING MODE (風扇)  
By selecting SWING mode with the VANE CONTROL button, the horizontal vane swings vertically. The remote controller displays “風扇”.
- (8) Cold air prevention in HEAT operation<MUH-C07/C09/C12TV>  
When any of the following conditions occurs in HEAT operation, the horizontal vane angle changes to Angle 1 automatically to prevent cold air blowing on users.
  - ① Compressor is not operating.
  - ② Defrosting is performed.
  - ③ Indoor coil thermistor RT12 reads 24°C or below.
  - ④ Indoor coil thermistor RT12 temperature is raising from 24°C or below, but it does not exceed 28°C.

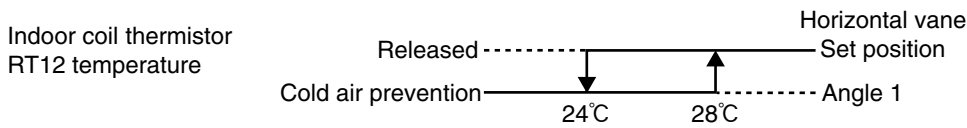

**NOTE:** If the temperature of RT12 reads from 24°C to 28°C at the air conditioner starting this control works.

- (9) ECONO COOL (省エネ) operation (ECONOmical operation)  
When the ECONO COOL button is pressed in COOL mode, set temperature is automatically set 2°C higher than that in COOL mode.  
Also the horizontal vane swings in various cycle according to the temperature of indoor heat exchanger (RT12). SWING operation makes you feel cooler than set temperature. So, even though the set temperature is higher than that in COOL mode, the air conditioner can keep comfort. As a result, energy can be saved.  
ECONO COOL operation is cancelled when the ECONO COOL button is pressed once again or VANE CONTROL button is pressed or change to other operation mode.

**NOTE:** ECONO COOL operation not work in COOL mode of “I FEEL CONTROL”.

**SWING operation**

In swing operation of ECONO COOL operation air flow is initially blew out upward (levelly). According to the temperature of indoor coil thermistor RT12 at starting of this operation, next downward blow time is decided. Then when the downward blow has been finished, next upward blow time is decided. For initial 10 minutes the swing operation is performed in table G~H for quick cooling (but G : RT12 is 24°C or less). Also, after 10 minutes when the difference of set temperature and room temperature is more than 2°C, the swing operation is performed in table D~H for more cooling (but D: RT12 is 20°C or less). The air conditioner repeats the swing operation in various cycle as follows.

	Temperature of indoor coil thermistor RT12	Downward blow time (sec.)	Upward(level) blow time (sec.)
A	15°C or less	2	23
B	15°C to 17°C	5	20
C	17°C to 18°C	8	17
D	18°C to 20°C	11	14
E	20°C to 21°C	14	11
F	21°C to 22°C	17	8
G	22°C to 24°C	20	5
H	more than 24°C	23	2

**h. TIMER OPERATION**

**h.1 How to set the timer**

- (1) Press OPERATE/STOP (ON/OFF) button to start the air conditioner.
- (2) Check that the current time is set correctly.

**NOTE:** Timer operation will not work without setting the current time. Initially “AM0:00” blinks at the current time display of TIME MONITOR, so set the current time correctly with CLOCK SET button.

- (3) Press ON/OFF TIMER buttons to select the operation.  
ON-TIMER button ..... AUTO START operation (ON timer)  
OFF-TIMER button .... AUTO STOP operation (OFF timer)

- (4) Press HR. and MIN. button (TIME SET button) to set the timer. Time setting is 10-minute units. HR. and MIN. button will work when "⊕→|" or "⊕→○" mark is flashing. These marks disappear in 1 minute. After setting the ON timer, check that OPERATION INDICATOR lamp of the indoor unit lights.

**NOTE1:** Be sure to place the remote controller at the position where its signal can reach the air conditioner even during TIMER operation, or the set time may deviate within the range of about 10 minutes.

**NOTE2:** Reset the timer in the following cases, or the set time may deviate and other malfunctions may occur.

- A power failure occurs.
- The circuit breaker functions.

**h.2 Cancel**

TIMER setting can be cancelled with the ON/OFF TIMER buttons. To cancel the ON timer, press the ON-TIMER button. To cancel the OFF timer, press the OFF-TIMER button. TIMER is cancelled and the display of set time disappears.

**PROGRAM TIMER**

- The OFF timer and ON timer can be used in combination.

- "↑" and "↓" display shows the order of the OFF timer and ON timer operation.

(Example 1) The current time is 8:00 PM.

The unit turns off at 11:00 PM, and on at 6:00 AM.

(Example 2) The current time is 11:00 AM.

The unit turns on at 5:00 PM, and off at 9:00 PM.

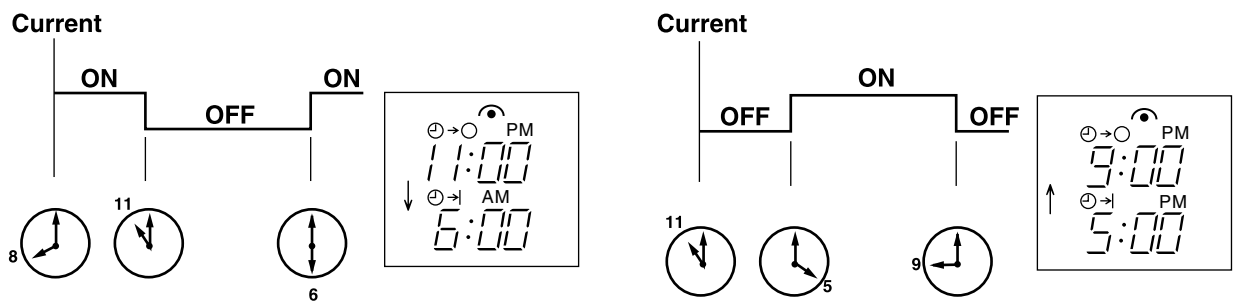

**NOTE:** TIMER setting will be cancelled by power failure or breaker functioning.

**i. EMERGENCY-TEST OPERATION**

In case of test run operation or emergency operation, use the EMERGENCY OPERATION switch on the front of the indoor unit. Emergency operation is available when the remote controller is missing, has failed or the batteries of remote controller run down. The unit will start and the OPERATION INDICATOR lamp will light.

The first 30 minutes of operation is the test run operation. This operation is for servicing. The indoor fan speed runs at High speed and the system is in continuous operation. (The thermostat is ON.)

After 30 minutes of test run operation the system shifts to EMERGENCY COOL/HEAT<MUH-C07/C09/C12TV only> MODE with a set temperature of 24°C.

The fan speed shifts to Med. speed.

The coil frost prevention works even in emergency operation, and defrosting <MUH-C07/C09/C12TV only> too.

In the test run or emergency operation, the horizontal vane operates in VANE AUTO (Ⓜ) mode.

Emergency operation continues until the EMERGENCY OPERATION switch is pressed once again (MU-C07/C09/C12TV)/ once or twice (MUH-C07/C09/C12TV) or the unit receives any signal from the remote controller. In case of latter normal operation will start.

**NOTE:** Do not press the EMERGENCY OPERATION switch during normal operation.

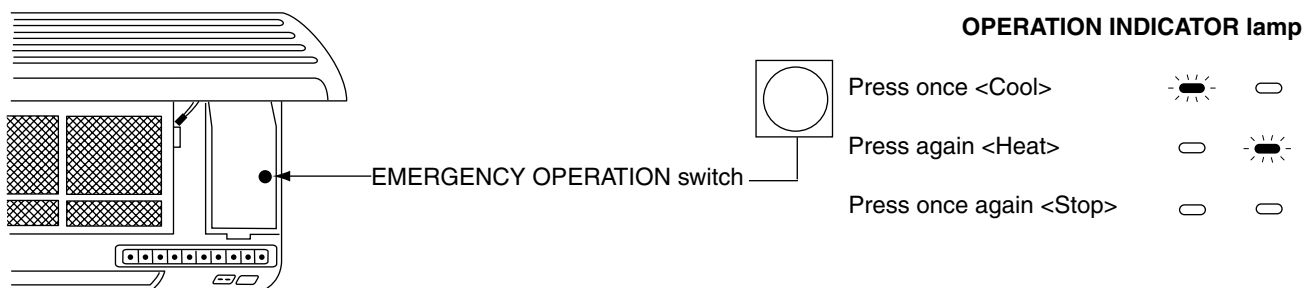

\* Heat is available only in MUH-C07/C09/C12TV.

B.1.11.2 MS Series

WIRELESS REMOTE CONTROLLER

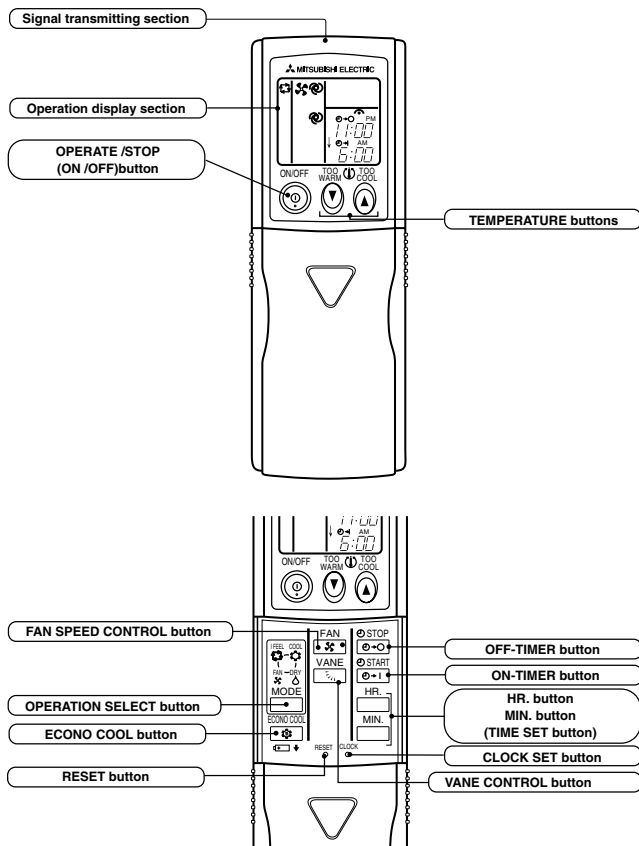

MS-C18TV, MU-C18TV  
MS-C24TV, MU-C24TV

Once the operation mode are set, the same operation mode can be repeated by simply turning the OPERATE/STOP(ON/OFF) button ON.

Indoor unit receives the signal with a beep tone.

When the system turns off, 3-minute time delay will operate to protect system from overload and compressor will not restart for 3 minutes.

a. "I FEEL CONTROL" (□) OPERATION

- (1) Press OPERATE/STOP(ON/OFF) button on the remote controller. OPERATION INDICATOR lamp of the indoor unit turns on with a beep tone.
- (2) Select "I FEEL CONTROL" (□) mode with the OPERATION SELECT button.
- (3) The operation mode is determined by the room temperature at start-up of the operation.

Initial room temperature	mode
25°C or more	COOL mode of "I FEEL CONTROL"
more than 13°C, less than 25°C	DRY mode of "I FEEL CONTROL"

- Once the mode is fixed, the mode does not change by room temperature afterwards.
- Under the ON-TIMER (⊖→|) operation, the mode is determined according to the room temperature at the set time the operation starts.
- When the system is stopped on the remote controller, and restarted within 2 hours in "I FEEL CONTROL" (□) mode, the system operates in previous mode automatically regardless of the room temperature.

INDOOR UNIT DISPLAY SECTION

Operation Indicator lamp

The operation indicator at the right side of the indoor unit indicates the operation state.

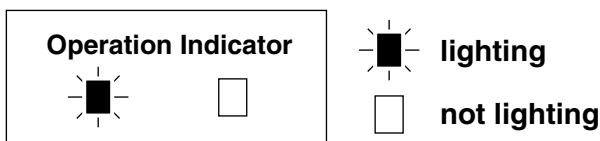

Indication	Operation state	Difference between target temperature and room temperature
	This shows that the air conditioner is operating to reach the target temperature. Please wait until the target temperature is obtained.	Approx. 2 °C or more
	This shows that the room temperature is approaching the target temperature.	Approx. 2 °C or less

Example

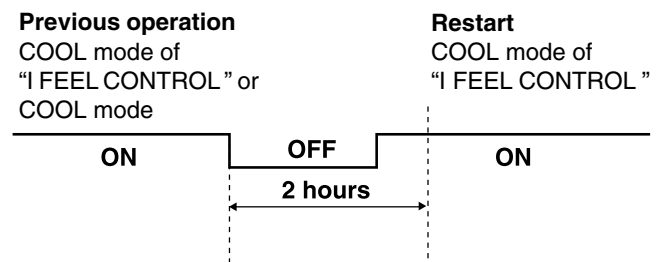

When the system is restarted after 2 hours and more, the operation mode is determined by the room temperature at start-up of the operation.

Operation timer chart

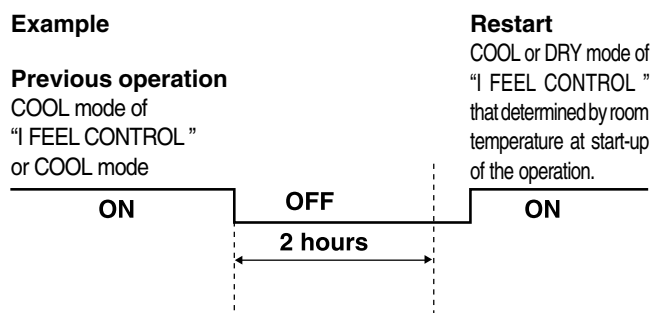



(4) The initial set temperature is decided by the initial room temperature.

Mode	Initial room temperature	Initial set temperature
COOL mode of "I FEEL CONTROL"	26°C or more	24°C
	25°C to 26°C	Initial room temperature minus 2°C
DRY mode of "I FEEL CONTROL"	more than 13°C, less than 25°C	Initial room temperature minus 2°C

\*1 When the system is restarted with the remote controller, the system operates with the previous set temperature regardless of the room temperature at restart. The set temperature is calculated by the previous set temperature.

(5) TEMPERATURE buttons

In "I FEEL CONTROL" (□) mode, set temperature is decided by the microprocessor based on the room temperature. In addition, set temperature can be controlled by TOO WARM or TOO COOL buttons when you feel too cool or too warm. Each time the TOO WARM or TOO COOL button is pressed the indoor unit receives the signal and emits a beep tone.

● Fuzzy control

When the TOO COOL or TOO WARM button is pressed the microprocessor changes the set temperature, considering the room temperature, the frequency of pressing TOO COOL or TOO WARM button and the user's preference to heat or cool. So this is called "Fuzzy control", and works only in "I FEEL CONTROL" mode. In DRY mode of "I FEEL CONTROL", the set temperature doesn't change.



... To raise the set temperature 1~2 degrees (°C)



... To lower the set temperature 1~2 degrees (°C)

— COOL mode of "I FEEL CONTROL" —

1. Indoor fan speed control

Indoor fan operates at the set speed by FAN SPEED CONTROL button. In AUTO the fan speed is as follows.

Initial temperature difference	Fan Speed	Difference between room temperature and set temperature during operation
Room temperature minus set temperature : 2 degrees or more .....	High	
Room temperature minus set temperature : Between 1 and 2 degrees .....	Med.	
Room temperature minus set temperature : less than 1 degree .....	Low	

2. Coil frost prevention

① Temperature control

When the indoor coil thermistor RT12 reads -1°C or below, the coil frost prevention mode starts immediately. However, the coil frost prevention doesn't work for 5 minutes since the compressor has started. The indoor fan operates at the set speed and the compressor stops for 5 minutes. After that, if RT12 still reads below -1°C this mode is prolonged until the RT12 reads over -1°C.

② Time control

When the three conditions as follows have been satisfied for 1 hour and 45 minutes, compressor stops for 3 minutes.

- Compressor has been continuously operating.
- Indoor fan speed is Low or Med..
- Room temperature is below 26°C.

When compressor stops, the accumulated time is cancelled and when compressor restarts, time counting starts from the beginning. Time counting also stops temporarily when the indoor fan speed becomes High or the room temperature exceeds 26°C. However, when two of the above conditions (b.and c.) are satisfied again. Time accumulation is resumed.

**Operation chart**

**Example**

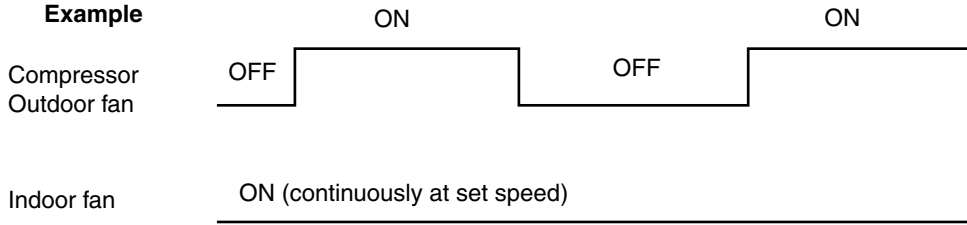

**—DRY mode of “I FEEL CONTROL ”—**

The system for dry operation uses the same refrigerant circuit as the cooling circuit.

The compressor and the indoor fan are controlled by the room temperature.

By such controls, indoor flow amounts will be reduced in order to lower humidity without much room temperature decrease.

**1. Indoor fan speed control**

Indoor fan operates at the set speed by FAN SPEED CONTROL button.

However, in AUTO fan operation, fan speed becomes Low.

**2. The operation of the compressor and indoor/outdoor fan**

Compressor operates by room temperature control and time control.

Set temperature is controlled to fall 2°C from initial room temperature.

Indoor fan and outdoor fan operate in the same cycle as the compressor.

- When the room temperature is 23°C or over:  
When the thermostat is ON, the compressor repeats 8 minutes ON and 3 minutes OFF.  
When the thermostat is OFF, the compressor repeats 4 minutes OFF and 1 minute ON.
- When the room temperature is under 23°C.  
When the thermostat is ON, the compressor repeats 2 minutes ON and 3 minutes OFF.  
When the thermostat is OFF, the compressor repeats 4 minutes OFF and 1 minute ON.

**Operation time chart**

**Example**

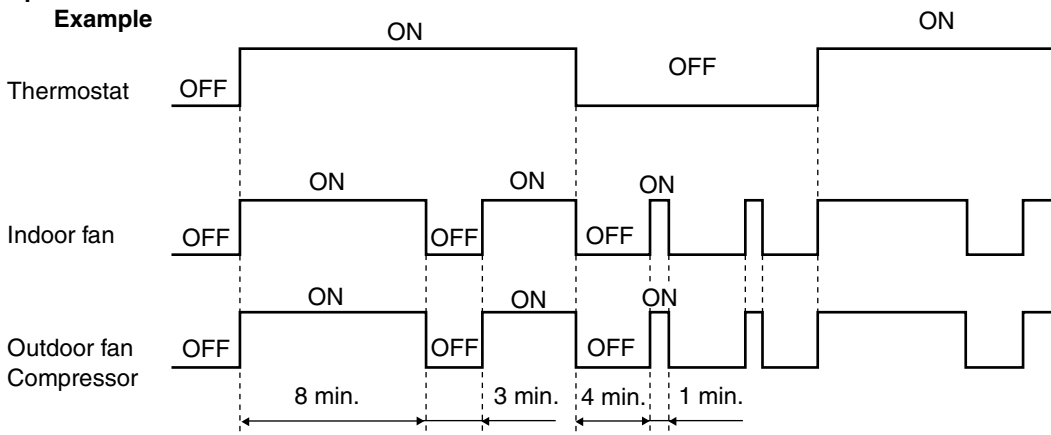

**3. Coil frost prevention**

The operation is as same as coil frost prevention during COOL mode of “I FEEL CONTROL ”.

Indoor fan operates at the set speed and the compressor stops for 5 minutes, because protection (Coil frost prevention) has the priority. However when coil frost prevention works while the compressor is not operating, it's speed becomes Low.

**b. COOL (❄️) OPERATION**

- (1) Press OPERATE/STOP (ON/OFF) button. OPERATION INDICATOR lamp of the indoor unit turns on with a beep tone.
- (2) Select COOL mode with the OPERATION SELECT button.
- (3) Press the TEMPERATURE buttons. (TOO WARM or TOO COOL button) to select the desired temperature. The setting range is 16 ~ 31°C.
  - \* Indoor fan continues to operate regardless of thermostat's OFF-ON at set speed.
  - \* Coil frost prevention is as same as COOL mode of "I FEEL CONTROL".

**c. DRY (☀️) OPERATION**

- (1) Press OPERATE/STOP (ON/OFF) button. OPERATION INDICATOR lamp of the indoor unit turns on with a beep tone.
- (2) Select DRY mode with the OPERATION SELECT button.
- (3) The microprocessor reads the room temperature and determines the set temperature. Set temperature is as shown on the right chart. Thermostat (SET TEMP.) does not work. The other operations are same as DRY mode of "I FEEL CONTROL".
- (4) DRY operation will not function when the room temperature is 13°C or below.

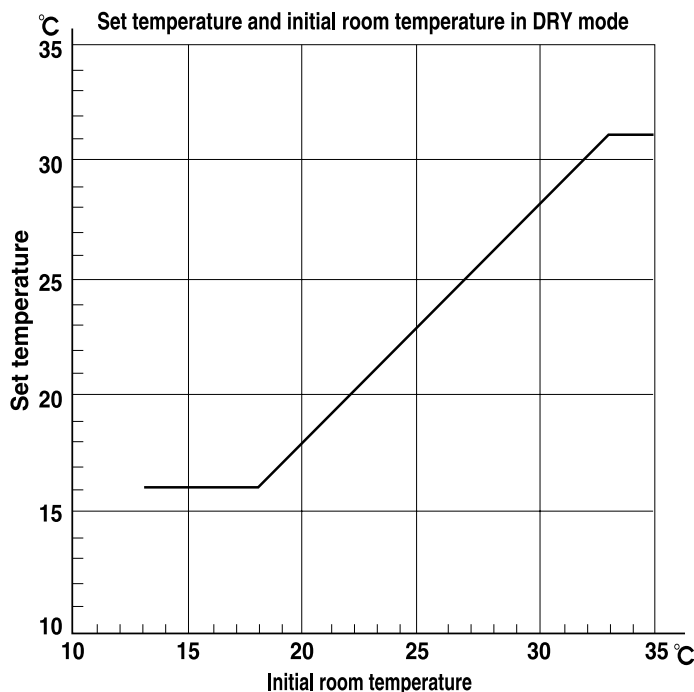

**d. FAN (🌀) OPERATION**

- (1) Press OPERATE/STOP (ON/OFF) button. OPERATION INDICATOR lamp of the indoor unit turns ON with a beep tone.
- (2) Select FAN mode with the OPERATION SELECT button.
- (3) Select the desired fan speed. When AUTO, it becomes Low. Only indoor fan operates. Outdoor unit does not operate.

**e. FAN MOTOR CONTROL**

- (1) Rotational frequency feedback control  
The indoor fan motor is equipped with a rotational frequency sensor, and outputs signal to the microprocessor to feedback the rotational frequency. Comparing the current rotational frequency with the target rotational frequency (High, Med., Low), the microprocessor controls IC141 and adjusts fan motor electric current to make the current rotational frequency close to the target rotational frequency. With this control, when the fan speed is switched, the rotational frequency changes smoothly.

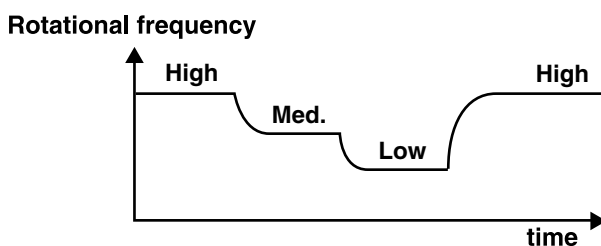

- (2) Fan motor lock-up protection  
When the rotational frequency feedback signal has not output for 12 seconds, (or when the microprocessor cannot detect the signal for 12 seconds) the fan motor is regarded locked-up. Then the electric current to the fan motor is shut off. 3 minutes later, the electric current is applied to the fan motor again. During the fan motor lock-up, the OPERATION INDICATOR lamp flashes on and off to show the fan motor abnormality.

**f. AUTO VANE OPERATION**

- (1) Vane motor drive  
These models are equipped with a stepping motor for the horizontal vane. The rotating direction, speed, and angle of the motor are controlled by pulse signals (approx. 12V) transmitted from microprocessor.
- (2) The horizontal vane angle and mode change as follows by pressing the VANE CONTROL button.

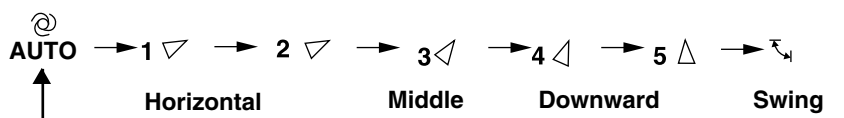

(3) Positioning

The vane is once pressed to the vane stopper below to confirm the standard position and then set to the desired angle. Confirming of standard position is performed in case of follows.

- (a) When the OPERATE/STOP (ON/OFF) button is pressed (POWER ON/OFF).
- (b) When the vane control is changed from AUTO to MANUAL.
- (c) When the SWING is finished.
- (d) When the test run starts.
- (e) When the power supply turns ON.

(4) VANE AUTO (Ⓜ) mode

In VANE AUTO mode, the microprocessor automatically determines the horizontal vane angle and operation to make the optimum room-temperature distribution.

① In COOL and DRY operation

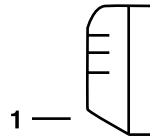

Vane angle is fixed to Angle 1.

② In FAN operation

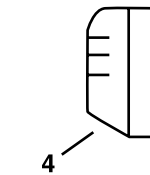

Vane angle is fixed to Angle 4.

(5) STOP (operation OFF) and ON-TIMER standby.

When the following cases occur, the horizontal vane returns to the closed position.

- (a) When the OPERATE/STOP(ON/OFF) button is pressed (POWER OFF).
- (b) When the operation is stopped by the emergency operation.
- (c) When the ON-TIMER is on standby.

(6) Dew prevention

During COOL or DRY operation at Vane Angle 4 or 5 when the compressor cumulative operation time exceeds 1 hour, the vane angle automatically changes to Angle 1 for dew prevention.

(7) SWING MODE (↕)

By selecting SWING mode with the VANE CONTROL button, the horizontal vane swings vertically. The remote controller displays “↕”.

(8) ECONO COOL (Ⓜ) operation (ECONOMical operation)

When the ECONO COOL button is pressed in COOL mode, set temperature is automatically set 2°C higher than that in COOL mode.

Also the horizontal vane swings in various cycle according to the temperature of indoor heat exchanger (RT12).

SWING operation makes you feel cooler than set temperature. So, even though the set temperature is higher than that in COOL mode, the air conditioner can keep comfort. As a result, energy can be saved.

ECONO COOL operation is cancelled when the ECONO COOL button is pressed once again or VANE CONTROL button is pressed or change to other operation mode.

**NOTE:** ECONO COOL operation not work in COOL mode of “I FEEL CONTROL”.

SWING operation

In swing operation of ECONO COOL operation air flow is initially blew out upward (levelly).

According to the temperature of indoor coil thermistor RT12 at starting of this operation, next downward blow time is decided. Then when the downward blow has been finished, next upward blow time is decided.

For initial 10 minutes the swing operation is performed in table G~H for quick cooling (but G : RT12 is 24°C or less).

Also, after 10 minutes when the difference of set temperature and room temperature is more than 2°C, the swing operation is performed in table D~H for more cooling (but D: RT12 is 20°C or less).

The air conditioner repeats the swing operation in various cycle as follows.

	Temperature of indoor coil thermistor RT12	Downward blow time (sec.)	Upward(level) blow time (sec.)
A	15°C or less	2	23
B	15°C to 17°C	5	20
C	17°C to 18°C	8	17
D	18°C to 20°C	11	14
E	20°C to 21°C	14	11
F	21°C to 22°C	17	8
G	22°C to 24°C	20	5
H	more than 24°C	23	2

**g. TIMER OPERATION**

**g.1 How to set the timer**

- (1) Press OPERATE/STOP (ON/OFF) button to start the air conditioner.
- (2) Check that the current time is set correctly.  
**NOTE:** Timer operation will not work without setting the current time. Initially "AM0:00" blinks at the current time display of TIMER MONITOR, so set the current time correctly with CLOCK SET button.
- (3) Press ON/OFF TIMER buttons to select the operation.  
 "ON-TIMER" button ..... AUTO START operation (ON timer)  
 "OFF-TIMER" button ..... AUTO STOP operation (OFF timer)
- (4) Press HR. and MIN. button (TIME set button) to set the timer. Time setting is 10-minute units.  
 HR. and MIN. button will work when "⊖→|" or "⊖→○" mark is flashing.  
 These marks disappear in 1 minute.  
 After setting the ON timer, check that OPERATION INDICATOR lamp of the indoor unit lights.  
**NOTE1:** Be sure to place the remote controller at the position where its signal can reach the air conditioner even during TIMER operation, or the set time may deviate within the range of about 10 minutes.  
**NOTE2:** Reset the timer in the following cases, or the set time may deviate and other malfunctions may occur.
  - A power failure occurs.
  - The circuit breaker functions.

**g.2 Cancel**

TIMER setting can be cancelled with the ON/OFF TIMER buttons.  
 To cancel the ON timer, press the "ON-TIMER" button.  
 To cancel the OFF timer, press the "OFF-TIMER" button.  
 TIMER is cancelled and the display of set time disappears.

**PROGRAM TIMER**

- The OFF timer and ON timer can be used in combination.
- "↑" and "↓" display shows the order of the OFF timer and ON timer operation.

(Example 1) The current time is 8:00 PM.  
 The unit turns off at 11:00 PM, and on at 6:00 AM.

(Example 2) The current time is 11:00 AM.  
 The unit turns on at 5:00 PM, and off at 9:00 PM.

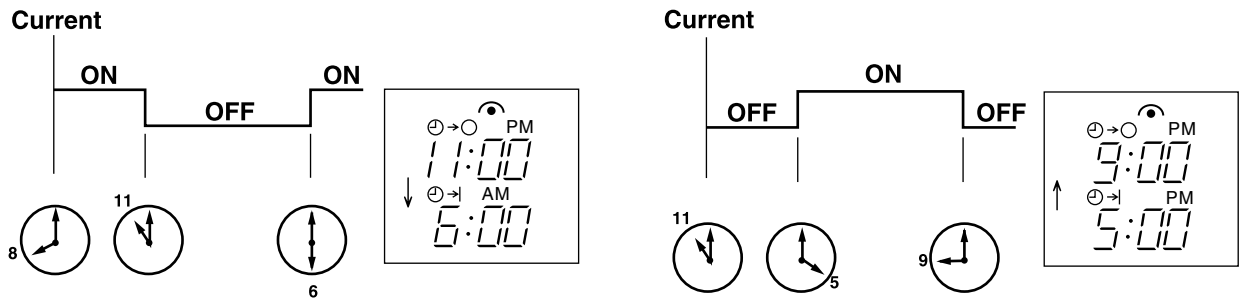

**NOTE:** TIMER setting will be cancelled by power failure or breaker functioning.

**h. EMERGENCY-TEST OPERATION**

In case of test run operation or emergency operation, use the EMERGENCY OPERATION switch on the front of the indoor unit. Emergency operation is available when the remote controller is missing, has failed or the batteries of remote controller run down. The unit will start and the OPERATION INDICATOR lamp will light.

The first 30 minutes of operation is the test run operation. This operation is for servicing. The indoor fan speed runs at High speed and the system is in continuous operation. (The thermostat is ON.)

After 30 minutes of test run operation the system shifts to EMERGENCY COOL MODE with a set temperature of 24°C. The fan speed shifts to Med. speed.

The coil frost prevention works even in emergency operation.

In the test run or emergency operation, the horizontal vane operates in VANE AUTO (Ⓢ) mode.

Emergency operation continues until the EMERGENCY OPERATION switch is pressed again or the unit receives any signal from the remote controller. In case of latter normal operation will start.

**NOTE:** Do not press the EMERGENCY OPERATION switch during normal operation.

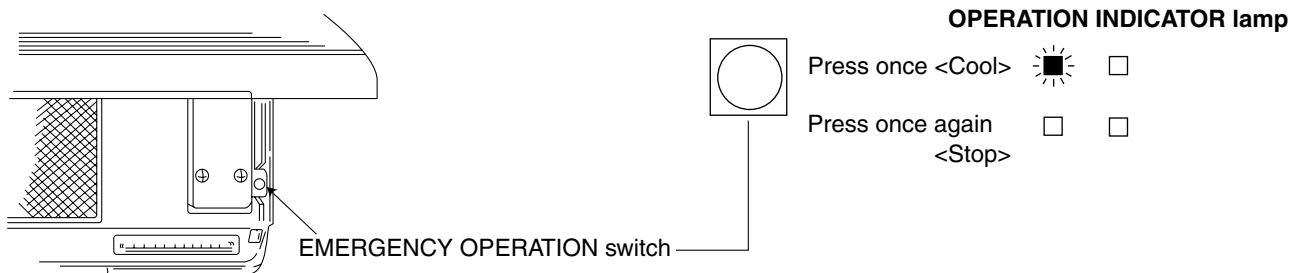

B.1.11.3 MSH Series

WIRELESS REMOTE CONTROLLER

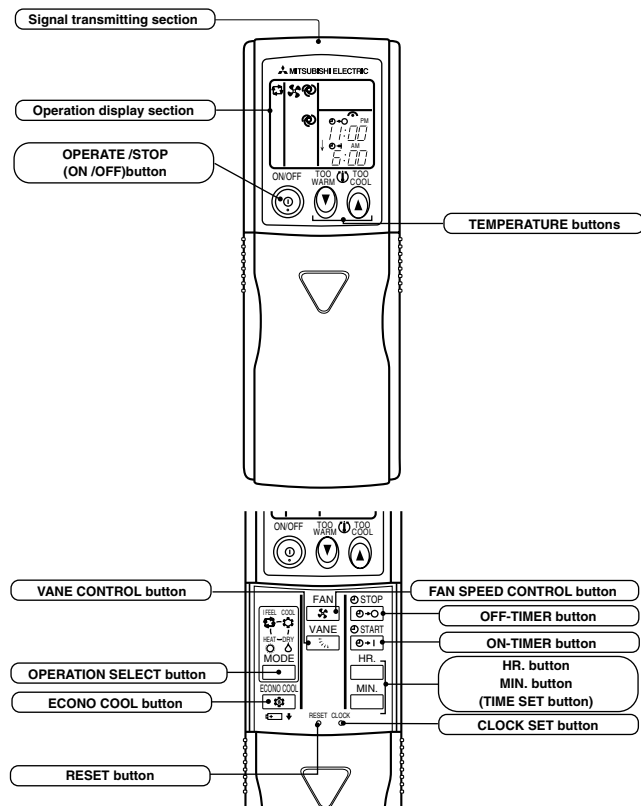

MSH-C18TV, MUH-C18TV  
MSH-C24TV, MUH-C24TV

Once the operation mode are set, the same operation mode can be repeated by simply turning the OPERATE/STOP (ON/ OFF) button ON.

Indoor unit receives the signal with a beep tone.

When the system turns off, 3-minute time delay will operate to protect system from overload and compressor will not restart for 3 minutes.

a. "I FEEL CONTROL" (□) OPERATION

- (1) Press OPERATE/STOP (ON/OFF) button on the remote controller. OPERATION INDICATOR lamp of the indoor unit turns on with a beep tone.
- (2) Select mode with the OPERATION SELECT button "I FEEL CONTROL".
- (3) The operation mode is determined by the room temperature at start-up of the operation.

Initial room temperature	Mode
25°C or more	COOL mode of "I FEEL CONTROL"
23°C to 25°C	DRY mode of "I FEEL CONTROL"
less than 23°C	HEAT mode of "I FEEL CONTROL"

- Once the mode is fixed, the mode does not change by room temperature afterwards.
- Under the ON-TIMER (⊕→|) operation, mode is determined according to the room temperature at the set time the operation starts.
- When the system is stopped on the remote controller, and restarted within 2 hours in "I FEEL CONTROL" (□) mode, the system operates in previous mode automatically regardless of the room temperature.

INDOOR UNIT DISPLAY SECTION

Operation Indicator lamp

The operation indicator at the right side of the indoor unit indicates the operation state.

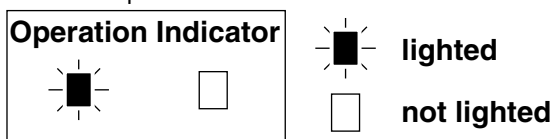

Indication	Operation state	Difference between target temperature and room temperature
	This shows that the air conditioner is operating to reach the target temperature. Please wait until the target temperature is obtained.	Approx. 2 °C or more
	This shows that the room temperature is approaching the target temperature.	Approx. 2 °C or less

Example

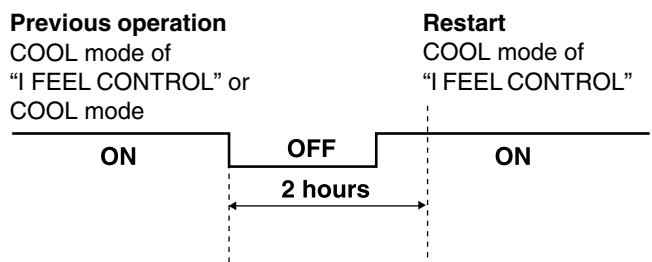

When the system is restarted after 2 hours and more, the operation mode is determined by the room temperature at start-up of the operation.

Example

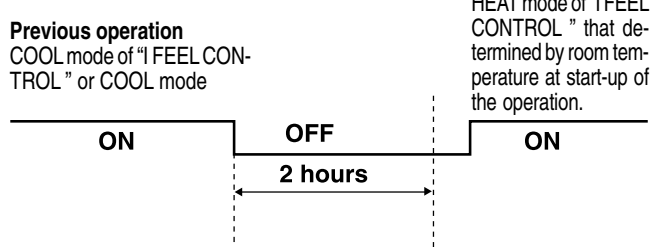

MICROPROCESSOR CONTROL

WALL-MOUNTED

(4) The initial set temperature is decided by the initial room temperature.

Mode	Initial room temperature	Initial set temperature	
COOL mode of "I FEEL CONTROL"	26°C or more	24°C	※1
	25°C to 26°C	Initial room temperature minus 2°C	
DRY mode of "I FEEL CONTROL"	23°C to 25°C	Initial room temperature minus 2°C	
HEAT mode of "I FEEL CONTROL"	less than 23°C	26°C	

※1 When the system is restarted with the remote controller, the system operates with the previous set temperature regardless of room temperature at restart.  
The set temperature is calculated by the previous set temperature.

(5) TEMPERATURE buttons

In "I FEEL CONTROL" (□) mode, set temperature is decided by the microprocessor based on the room temperature. In addition, set temperature can be controlled by TOO WARM or TOO COOL buttons when you feel too cool or too warm. Each time the TOO WARM or TOO COOL button is pressed, the indoor unit receives the signal and emits a beep tone.

● Fuzzy control

When the TOO COOL or TOO WARM button is pressed, the microprocessor changes the set temperature, considering the room temperature, the frequency of pressing TOO COOL or TOO WARM button and the user's preference to heat or cool. So this is called "Fuzzy control", and works only in "I FEEL CONTROL" mode. In DRY mode of "I FEEL CONTROL", the set temperature doesn't change.



... To raise the set temperature 1~2 degrees (°C)



... To lower the set temperature 1~2 degrees (°C)

— COOL mode of "I FEEL CONTROL" —

1. Indoor fan speed control

Indoor fan operates at the set speed by FAN SPEED CONTROL button. In AUTO the fan speed is as follows.

Initial temperature difference	Fan Speed	Difference between room temperature and set temperature during operation
Room temperature minus set temperature : 1.7 degrees or more .....	High	
Room temperature minus set temperature : Between 1 and 1.7 degrees .....	Med.	
Room temperature minus set temperature : less than 1 degree .....	Low	

2. Coil frost prevention

① Temperature control

When the indoor coil thermistor RT12 reads 3°C or below, the coil frost prevention mode starts immediately. However, the coil frost prevention doesn't work for 5 minutes since the compressor has started. The indoor fan operates at the set speed and the compressor stops for 5 minutes. After that, if RT12 still reads below 3°C this mode prolonged until the RT12 reads over 3°C.

② Time control

When the three conditions as follows have been satisfied for 1 hour and 45 minutes, compressor stops for 3 minutes.

- a. Compressor has been continuously operating.
- b. Indoor fan speed is Low or Med..
- c. Room temperature is below 26°C.

When compressor stops, the accumulated time is cancelled and when compressor restarts, time counting starts from the beginning.

Time counting also stops temporarily when the indoor fan speed becomes High or the room temperature exceeds 26°C. However, when two of the above conditions (b.and c.) are satisfied again. Time accumulation is resumed.



**Operation chart**

**Example**

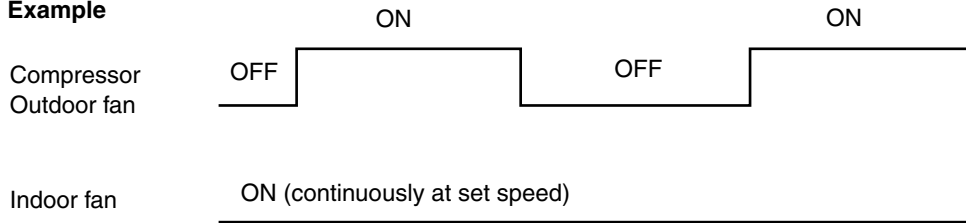

**3. Outdoor fan control <MSH-C24TV only>**

Outdoor fan speed is controlled according to the temperature of ambient temperature thermistor RT63.

Outdoor fan Low operation : When the outside temperature decreases to 28°C or less. Until the outside temperature goes to 31°C or more.

Outdoor fan High operation : Until the outside temperature decreases to 28°C or less. When the outside temperature goes to 31°C or more.

Ambient temperature thermistor RT63 temperature

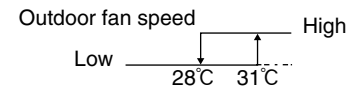

**NOTE:** If the temperature of RT63 reads from 28°C to 31°C at the air conditioner starting, outdoor fan speed is High.

**—DRY mode of “I FEEL CONTROL”—**

The system for dry operation uses the same refrigerant circuit as the cooling circuit.

The compressor and the indoor fan are controlled by the room temperature.

By such controls, indoor flow amounts will be reduced in order to lower humidity without much room temperature decrease.

**1. Indoor fan speed control**

Indoor fan operates at the set speed by FAN SPEED CONTROL button.

However, in AUTO fan operation, fan speed becomes Low.

**2. The operation of the compressor and indoor/outdoor fan**

Compressor operates by room temperature control and time control.

Set temperature is controlled to fall 2°C from initial room temperature.

Indoor fan and outdoor fan operate in the same cycle as the compressor.

- When the room temperature is 23°C or over:  
When the thermostat is ON, the compressor repeats 8 minutes ON and 3 minutes OFF.  
When the thermostat is OFF, the compressor repeats 4 minutes OFF and 1 minute ON.
- When the room temperature is under 23°C.  
When the thermostat is ON, the compressor repeats 2 minutes ON and 3 minutes OFF.  
When the thermostat is OFF, the compressor repeats 4 minutes OFF and 1 minute ON.

**Operation time chart**

**Example**

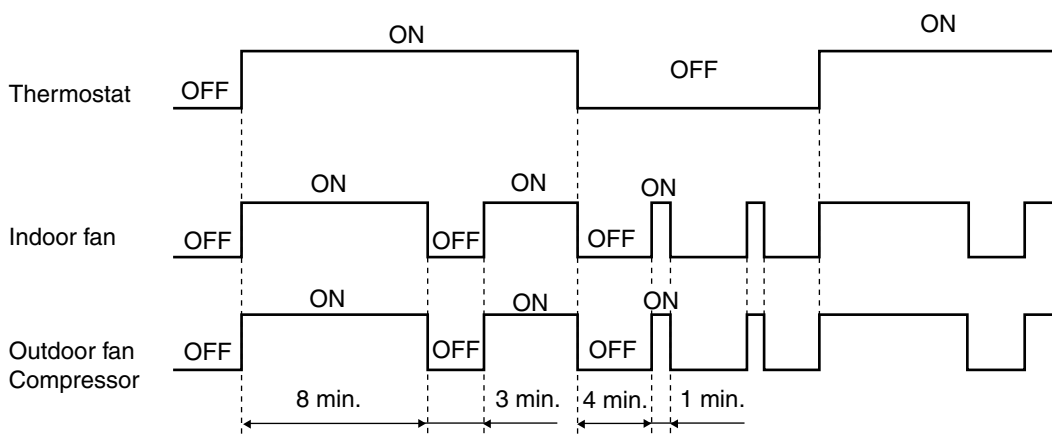

**3. Coil frost prevention**

- The operation is as same as coil frost prevention during COOL mode of “I FEEL CONTROL”.
- Indoor fan operates at the set speed and the compressor stops for 5 minutes, because protection(Coil frost prevention) has the priority.  
However, when coil frost prevention works while the compressor is not operating, it's speed becomes Low.

**4. Outdoor fan control <MSH-C24TV only>**

Outdoor fan control is as same as one of COOL mode of “I FEEL CONTROL”.

MICROPROCESSOR CONTROL

WALL-MOUNTED

— HEAT mode of “I FEEL CONTROL” —

1. Indoor fan speed control

(1) In AUTO the fan speed is as follows.

Initial temperature difference	Fan speed	Difference between room temperature and set temperature during operation
Set temperature minus room temperature: 2 degrees or more .....	High	
Set temperature minus room temperature: Between 1 and 2 degrees ....	Med.	
Set temperature minus room temperature: less than 1 degree .....	Low	

(2) Cold air prevention control

The fan runs at set speed when the indoor coil thermistor RT12 temperature exceeds 22°C. The fan operates at Very Low when the temperature of indoor coil thermistor RT12 is below 18°C. But the fan stops when the indoor fan operates at Very Low and the room temperature is 15°C or less.

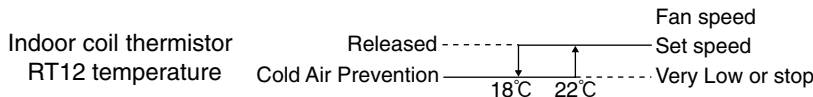

**NOTE:** If the temperature of RT12 reads from 18°C to 22°C at the air conditioner starting and also after defrosting, this control works.

(3) Warm air control

When compressor starts in heating operation or after defrosting, the fan changes the speed due to the indoor coil thermistor RT12 temperature to blow out warm air.

After releasing of cold air prevention, when the indoor coil thermistor RT12 temperature is 37°C or above, the fan speed shifts to the set speed, and when the fan speed is changed by the remote controller, the fan speed is the set speed. When the indoor coil thermistor RT12 temperature is less than 37°C, the fan speed is controlled by time as below.

<Time condition>	<Indoor fan speed>
less than 2 minutes .....	Low
2 minutes to 4 minutes .....	Med.
4 minutes or more .....	High

The upper limit of the fan speed is the set speed.

If the thermostat turns off, this operation changes to flow soft control.

(4) Flow soft control

After the thermostat turns off, the indoor fan operates at Very Low.

**NOTE:** When the thermostat turns on, the fan operates at the set speed. Due to the cold air prevention control, the fan does not start at set speed until the indoor coil thermistor RT12 reads 22°C or more.

2. Outdoor fan control <MSH-C24TV only>

Outdoor fan speed is controlled according to the temperature of ambient temperature thermistor RT63.

Outdoor fan Low operation : Until the outside temperature decreases to 12°C.

When the outside temperature goes to 14°C or more.

Outdoor fan High operation : When the outside temperature decreases to 12°C or less.

Until the outside temperature goes to 14°C.

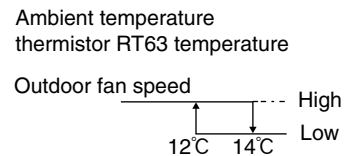

3. High pressure protection

During heating operation, the outdoor fan motor is controlled by the temperature of indoor coil thermistor RT12 for excess rise protection of compressor discharge pressure.

Outdoor fan OFF: 56°C

Outdoor fan ON : 52°C

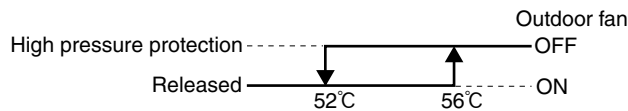

High pressure protection chart

Example

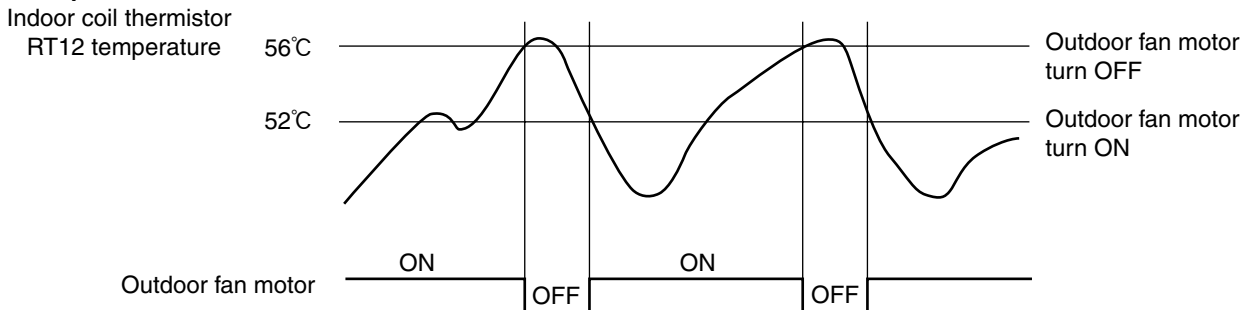

**NOTE:** During high pressure protection and for 4 minutes and 15 seconds (MUH-C18TV)/ 10 seconds (MUH-C24TV) after high pressure protection, defrosting of outdoor heat exchanger is not detected by the defrost thermistor RT61.

4. Defrosting

Defrosting of outdoor heat exchanger is controlled by deicer P.C. board, with detection by the defrost thermistor RT61.

(1) Starting conditions of defrost

When all conditions of a) ~ c) are satisfied, the defrosting operation starts.

- a) Under the heat operation, the compressor cumulative operation time exceeds 40 minutes without the defrosting operation working.
- b) The defrost thermistor RT61 reads  $-2.7^{\circ}\text{C}$  or less (MSH-C18TV) /  $-2.0^{\circ}\text{C}$  or less (MSH-C24TV).
- c) After releasing the high pressure protection 4 minutes and 15 seconds (MSH-C18TV) / 10 seconds (MSH-C24TV) have elapsed.

(2) Releasing conditions of defrost

When the condition d) or e) is satisfied, the defrosting operation stops.

- d) The defrost thermistor RT61 reads  $16.3^{\circ}\text{C}$  or more (MSH-C18TV) /  $20.0^{\circ}\text{C}$  or more (MSH-C24TV).
- e) The defrosting time exceeds 10 minutes.

(3) Defrosting time chart

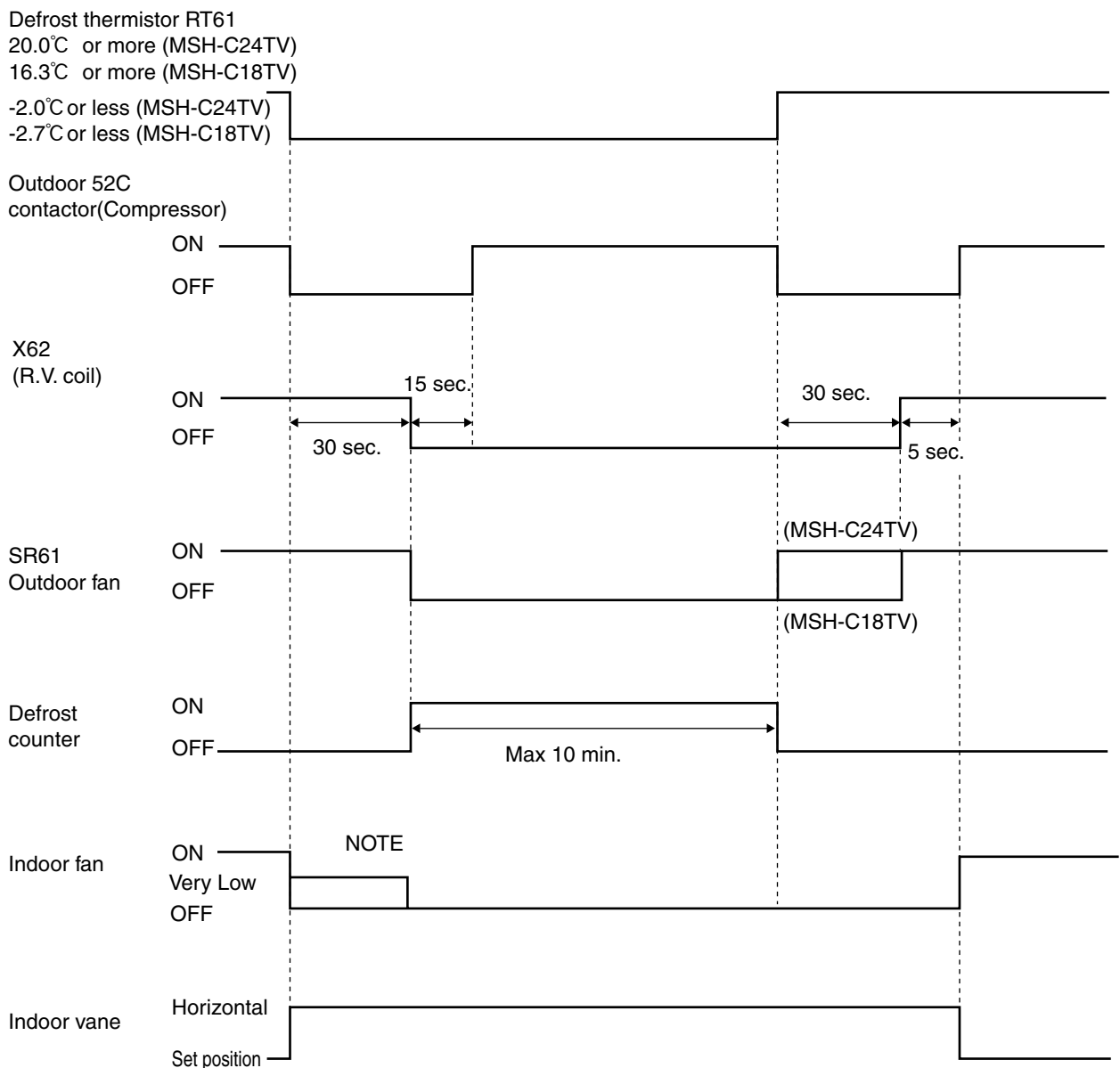

**NOTE:** • When the indoor coil thermistor RT12 reads above  $18^{\circ}\text{C}$ , indoor fan operates at Very Low for 30 seconds.  
 • When the indoor coil thermistor RT12 reads  $18^{\circ}\text{C}$  or less, the indoor fan stops.

**5. R.V. coil control**

- Heating .....ON
- Cooling .....OFF
- Dry .....OFF

**NOTE:** The 4-way valve reverses for 5 seconds right before start-up of the compressor.

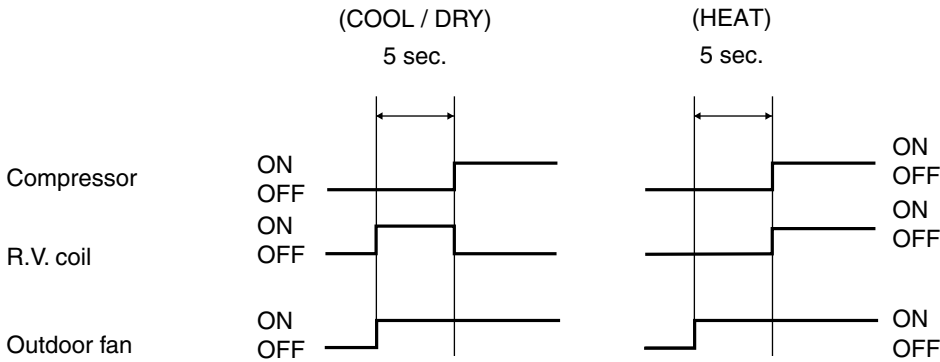

**b. COOL (❄️) OPERATION**

- (1) Press OPERATE/STOP (ON/OFF) button. OPERATION INDICATOR lamp of the indoor unit turns on with a beep tone.
  - (2) Select COOL mode with the OPERATION SELECT button.
  - (3) Press the TEMPERATURE buttons. (TOO WARM or TOO COOL button) to select the desired temperature. The setting range is 16 ~ 31°C.
- \* Indoor fan continues to operate regardless of thermostat's OFF-ON at set speed.
  - \* Coil frost prevention is as same as COOL mode of "I FEEL CONTROL".

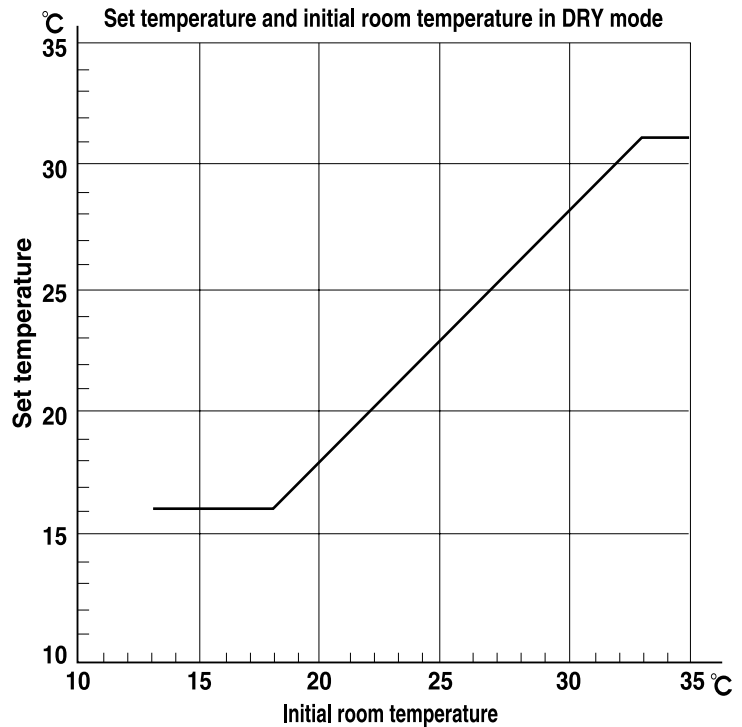

**c. DRY (☀️) OPERATION**

- (1) Press OPERATE/STOP (ON/OFF) button. OPERATION INDICATOR lamp of the indoor unit turns on with a beep tone.
- (2) Select DRY mode with the OPERATION SELECT button.
- (3) The microprocessor reads the room temperature and determines the set temperature. Set temperature is as shown on the right chart. Thermostat (SET TEMP.) does not work. The other operations are same as DRY mode of "I FEEL CONTROL".
- (4) DRY operation will not function when the room temperature is 13°C or below.

**d. HEAT (🔥) OPERATION**

- (1) Press OPERATE/STOP (ON/OFF) button. OPERATION INDICATOR lamp of the indoor unit turns on with a beep tone.
- (2) Select HEAT mode with the OPERATION SELECT button.
- (3) Press TEMPERATURE buttons (TOO WARM or TOO COOL button) to select the desired temperature. The setting range is 16 ~ 31°C.
- (4) Indoor fan speed control, high pressure protection, defrosting, R.V. coil control are the same as HEAT mode of "I FEEL CONTROL".

MICROPROCESSOR CONTROL WALL-MOUNTED

**e. FAN MOTOR CONTROL**

(1) Rotational frequency feedback control

The indoor fan motor is equipped with a rotational frequency sensor, and outputs signal to the microprocessor to feedback the rotational frequency. Comparing the current rotational frequency with the target rotational frequency (High, Med., Low), the microprocessor controls IC141 and adjusts fan motor electric current to make the current rotational frequency close to the target rotational frequency. With this control, when the fan speed is switched, the rotational frequency changes smoothly.

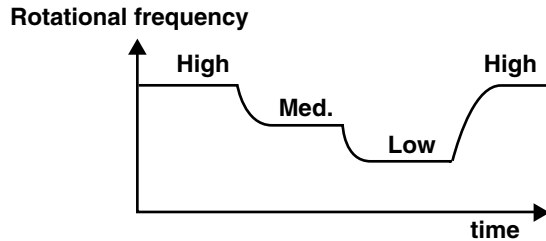

(2) Fan motor lock-up protection

When the rotational frequency feedback signal has not output for 12 seconds, (or when the microprocessor cannot detect the signal for 12 seconds) the fan motor is regarded locked-up. Then the electric current to the fan motor is shut off. 3 minutes later, the electric current is applied to the fan motor again. During the fan motor lock-up, the OPERATION INDICATOR Indicator lamp flashes on and off to show the fan motor abnormality.

**f. AUTO VANE OPERATION**

(1) Vane motor drive

These models are equipped with a stepping motor for the horizontal vane. The rotating direction, speed, and angle of the motor are controlled by pulse signals (approx. 12V) transmitted from indoor microprocessor.

(2) The horizontal vane angle and mode changes as follows by pressing the VANE CONTROL button.

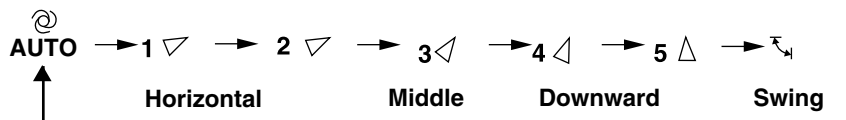

(3) Positioning

The vane is once pressed to the vane stopper below to confirm the standard position and then set to the desired angle.

Confirming of standard position is performed in case of follows.

- (a) When the OPERATE/STOP (ON/OFF) button is pressed.
- (b) When the vane control is changed from AUTO to MANUAL.
- (c) When the SWING is finished.
- (d) When the test run starts.
- (e) When the power supply turns ON.

(4) VANE AUTO (@) mode

In VANE AUTO mode, the microprocessor automatically determines the vane angle and operation to make the optimum room-temperature distribution.

① In COOL and DRY operation

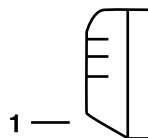

Vane angle is fixed to Angle 1.

② In HEAT operation

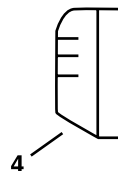

Vane angle is fixed to Angle 4.

- (5) STOP (operation OFF) and ON-TIMER standby.  
When the following cases occur, the horizontal vane returns to the closed position.
  - (a) When the OPERATE/STOP (ON/OFF) button is pressed (POWER OFF).
  - (b) When the operation is stopped by the emergency operation.
  - (c) When the ON-TIMER is on standby.
- (6) Dew prevention  
During COOL or DRY operation at Vane Angle 4 or 5 when the cumulative operation time of compressor exceeds 1 hour, the vane angle automatically changes to Angle 1 for dew prevention.
- (7) SWING MODE (風扇)   
By selecting SWING mode with the VANE CONTROL button, the horizontal vane swings vertically. The remote controller displays “風扇”.
- (8) Cold air prevention in HEAT operation  
When any of the following conditions occurs in HEAT operation, the vane angle changes to Angle 1 automatically to prevent cold air blowing on users.
  - ① Compressor is not operating.
  - ② Defrosting is performed.
  - ③ Indoor coil thermistor RT12 reads 24°C or below.
  - ④ Indoor coil thermistor RT12 temperature is raising from 24°C or below, but it does not exceed 28°C.



**NOTE:** If the temperature of RT12 reads from 27°C to 28°C at the air conditioner starting, this control works.

- (9) ECONO COOL (風扇) operation (ECONOmical operation)   
When the ECONO COOL button is pressed in COOL mode, set temperature is automatically set 2°C higher than that in COOL mode.  
Also the horizontal vane swings in various cycle according to the temperature of indoor heat exchanger (RT12). SWING operation makes you feel cooler than set temperature. So, even though the set temperature is higher than that in COOL mode, the air conditioner can keep comfort. As a result, energy can be saved.  
ECONO COOL operation is cancelled when the ECONO COOL button is pressed once again or VANE CONTROL button is pressed or change to other operation mode.  
**NOTE:** ECONO COOL operation not work in COOL mode of “I FEEL CONTROL”.

**SWING operation**

In swing operation of ECONO COOL operation air flow is initially blew out upward (levelly). According to the temperature of indoor coil thermistor RT12 at starting of this operation, next downward blow time is decided. Then when the downward blow has been finished, next upward blow time is decided. For initial 10 minutes the swing operation is performed in table G~H for quick cooling (but G : RT12 is 24°C or less). Also, after 10 minutes when the difference of set temperature and room temperature is more than 2°C, the swing operation is performed in table D~H for more cooling (but D: RT12 is 20°C or less). The air conditioner repeats the swing operation in various cycle as follows.

	Temperature of indoor coil thermistor RT12	Downward blow time (sec.)	Upward(level) blow time (sec.)
A	15°C or less	2	23
B	15°C to 17°C	5	20
C	17°C to 18°C	8	17
D	18°C to 20°C	11	14
E	20°C to 21°C	14	11
F	21°C to 22°C	17	8
G	22°C to 24°C	20	5
H	more than 24°C	23	2

**g. TIMER OPERATION**

**g.1 How to set the timer**

- (1) Press OPERATE/STOP (ON/OFF) button to start the air conditioner.
- (2) Check that the current time is set correctly.  
**NOTE:** Timer operation will not work without setting the current time. Initially "AM0:00" blinks at the current time display of TIME MONITOR, so set the current time correctly with CLOCK SET button.
- (3) Press TIMER CONTROL button to select the operation.  
 "ON-TIMER" button... AUTO START operation (ON timer)  
 "OFF-TIMER" button... AUTO STOP operation (OFF timer)
- (4) Press HR. and MIN. button to set the timer. Time setting is 10-minute units.  
 HR. and MIN. button will work when "⊖→|" or "⊖→○" mark is flashing.  
 These marks disappear in 1 minute.  
 After setting the ON timer, check that OPERATION INDICATOR lamp of the indoor unit lights.  
**NOTE1:** Be sure to place the remote controller at the position where its signal can reach the air conditioner even during TIMER operation, or the set time may deviate within the range of about 10 minutes.  
**NOTE2:** Reset the timer in the following cases, or the set time may deviate and other malfunctions may occur.
  - A power failure occurs.
  - The circuit breaker functions.

**g.2 Cancel**

TIMER setting can be cancelled with the ON/OFF TIMER buttons.  
 To cancel the ON timer, press the "ON-TIMER" button.  
 To cancel the OFF timer, press the "OFF-TIMER" button.  
 TIMER is cancelled and the display of set time disappears.

**PROGRAM TIMER**

- The OFF timer and ON timer can be used in combination.
- "↑" and "↓" display shows the order of the OFF timer and ON timer operation.

(Example 1) The current time is 8:00 PM.  
 The unit turns off at 11:00 PM,  
 and on at 6:00 AM.

(Example 2) The current time is 11:00 AM.  
 The unit turns on at 5:00 PM,  
 and off at 9:00 PM.

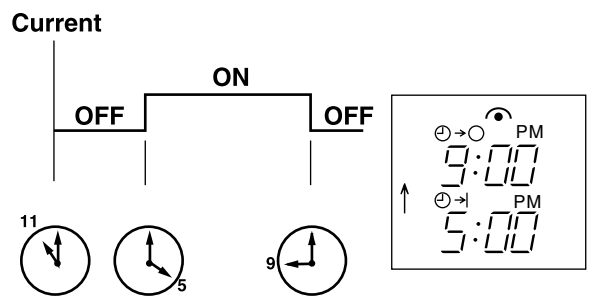
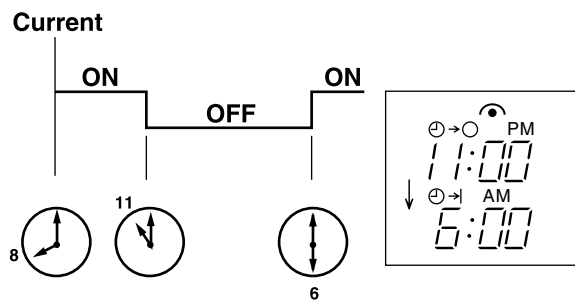

**NOTE:** TIMER setting will be cancelled by power failure or breaker functioning.

**h. EMERGENCY-TEST OPERATION**

In case of test run operation or emergency operation, use the EMERGENCY OPERATION switch on the front of the indoor unit. Emergency operation is available when the remote controller is missing, has failed or the batteries of remote controller run down. The unit will start and the OPERATION INDICATOR lamp will light.

The first 30 minutes of operation is the test run operation. This operation is for servicing. The indoor fan speed runs at High speed and the system is in continuous operation. (The thermostat is ON.)

After 30 minutes of test run operation the system shifts to EMERGENCY COOL/HEAT MODE with a set temperature of 24°C.

The fan speed shifts to Med. speed.

The coil frost prevention works even in emergency operation, and defrosting too.

In the test run or emergency operation, the horizontal vane operates in VANE AUTO (Ⓢ) mode.

Emergency operation continues until the EMERGENCY OPERATION switch is pressed once or twice or the unit receives any signal from the remote controller. In case of latter normal operation will start.

**NOTE:** Do not press the EMERGENCY OPERATION switch during normal operation.

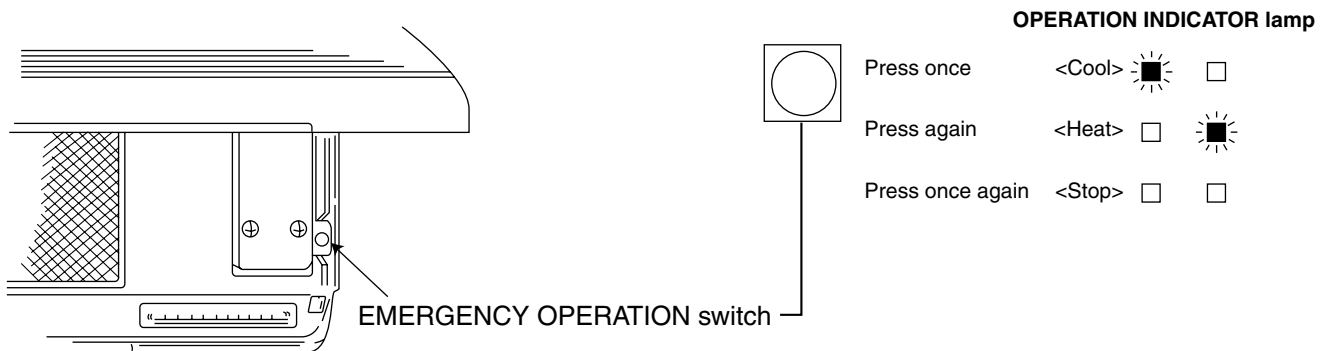

MICROPROCESSOR CONTROL

WALL-MOUNTED