

## OUTDOOR UNIT

# PARTS CATALOG

No. OBB590

### Models

**MUZ-EF25VE** - E1

**MUZ-EF25VEH** - E1

**MUZ-EF35VE** - E1

**MUZ-EF35VEH** - E1

**MUZ-EF42VE** - E1

**MUZ-EF50VE** - E1

MUZ-EF25VE MUZ-EF25VEH  
MUZ-EF35VE MUZ-EF35VEH  
MUZ-EF42VE

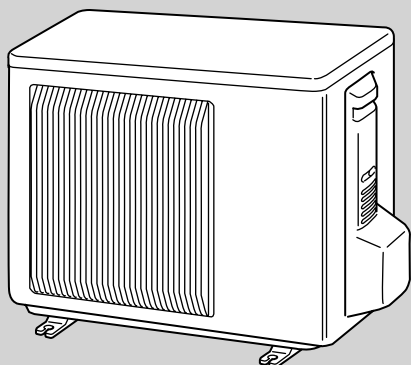

### CONTENTS

1. RoHS PARTS LIST..... 2

**SERVICE MANUAL (OBH590)**

**NOTE:**  
RoHS compliant products have <G> mark on the spec name plate.



MUZ-EF25VE MUZ-EF25VEH MUZ-EF35VE MUZ-EF35VEH MUZ-EF42VE  
1-1. OUTDOOR UNIT STRUCTURAL PARTS AND FUNCTIONAL PARTS

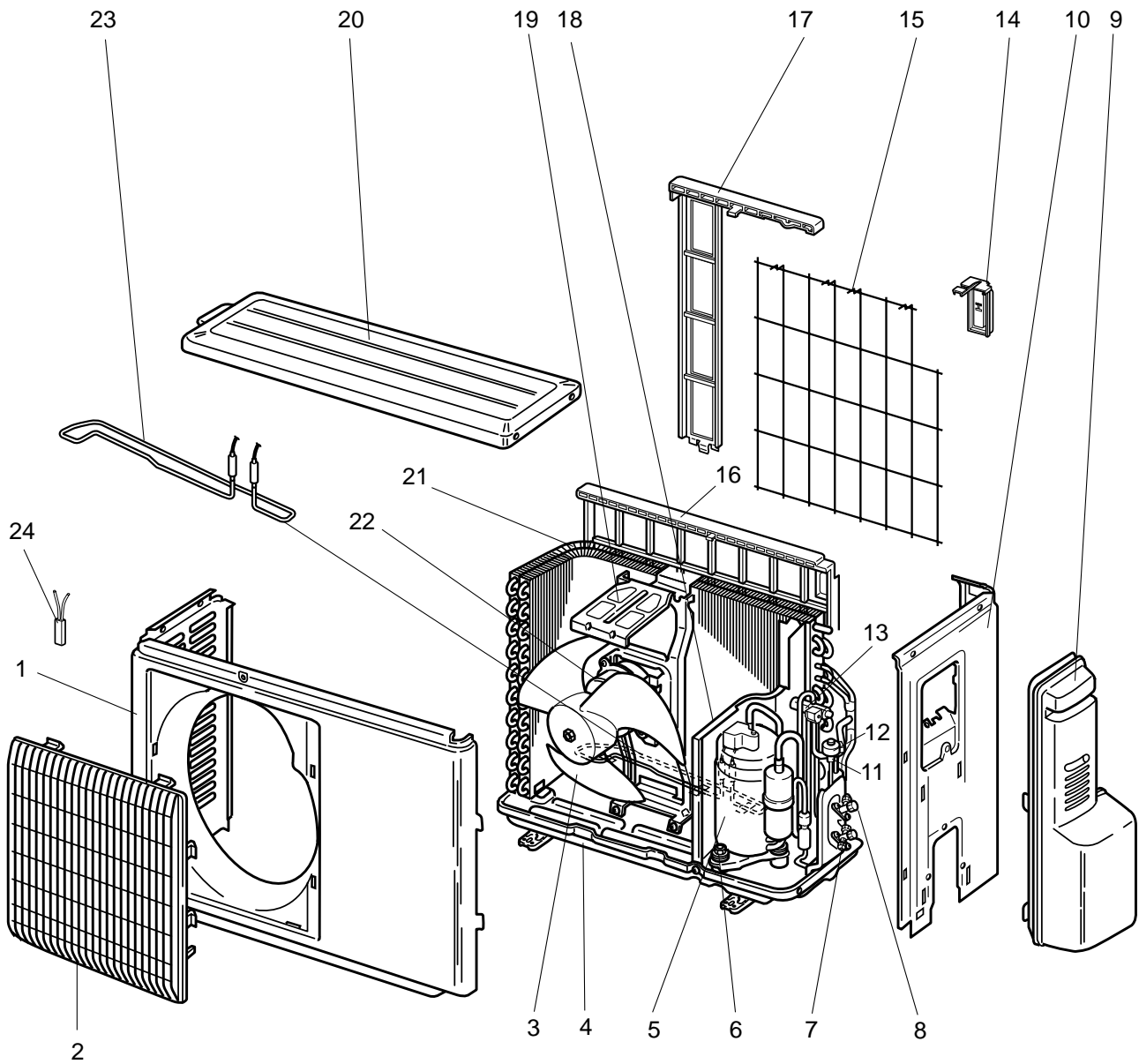

## 1-1. OUTDOOR UNIT STRUCTURAL PARTS AND FUNCTIONAL PARTS

Part numbers that are circled are not shown in the illustration.

No.	RoHS	Part No.	Part Name	Symbol in Wiring Diagram	Q'ty/unit					Remarks	
					MUZ-EF25		MUZ-EF35		MUZ-EF42		
					VE - [E1]	VEH- [E1]	VE - [E1]	VEH - [E1]	VE- [E1]		
1	G	E12 927 232	CABINET		1	1	1	1	1		
2	G	E12 927 521	GRILLE		1	1	1	1	1		
3	G	E12 927 501	PROPELLER		1	1	1	1	1		
4	G	E12 D69 290	BASE		1		1		1		
	G	E12 D70 290				1		1			
5	G	E12 G10 900	COMPRESSOR	MC	1	1				KNB073FKFMC	
	G	E12 G11 900					1	1			KNB092FFAMC
	G	E12 G12 900							1		SNB130FGAMT
6	G	E12 065 506	COMPRESSOR RUBBER SET		3	3	3	3		3 RUBBERS/SET	
	G	E12 C34 506						3			
7	G	E12 D69 661	STOP VALVE (GAS)		1	1	1	1		ø9.52	
	G	E12 927 661						1			
8	G	E12 D58 662	STOP VALVE (LIQUID)		1	1	1	1		ø6.35	
	G	E12 927 662						1			
9	G	E12 927 245	SERVICE PANEL		1	1	1	1	1		
10	G	E12 G11 233	BACK PANEL		1						
	G	E12 G13 233				1					
	G	E12 927 233					1				
	G	E12 G14 233						1			
	G	E12 C37 233							1		
11	G	E12 927 640	EXPANSION VALVE		1	1	1	1			
	G	E12 838 640						1			
12	G	E12 G10 493	EXPANSION VALVE COIL	LEV	1	1	1	1	1		
13	G	E12 927 961	4-WAY VALVE		1	1	1	1	1		
14	G	E12 928 079	THERMO HOLDER			1					
	G	E12 930 079					1				
15	G	E12 928 525	CONDENSER WIRE NET			1					
	G	E12 930 525					1				
16	G	E12 B83 523	CONDENSER NET		1		1		1		
	G	E12 929 523					1		1		
17	G	E12 928 523	CONDENSER NET			1					
	G	E12 930 523					1				
18	G	E12 G10 293	SEPARATOR		1						
	G	E12 G13 293				1					
	G	E12 G11 293					1		1		
	G	E12 G14 293						1			
19	G	E12 927 515	MOTOR SUPPORT		1	1					
	G	E12 929 515				1	1		1		
20	G	E12 927 297	TOP PANEL		1	1	1	1	1		
21	G	E12 G10 630	OUTDOOR HEAT EXCHANGER		1	1					
	G	E12 G11 630				1	1				
	G	E12 G12 630						1			
22	G	E12 G11 301	OUTDOOR FAN MOTOR	MF	1	1	1	1	1	RC0J50-□□	
23	G	E12 C36 526	DEFROST HEATER	H		1		1			
24	G	E12 C36 381	HEATER PROTECTOR	26H		1		1			
25	G	E12 927 937	CAPILLARY TUBE		1	1	1	1	1	ø3.0xø2.0x240	
26	G	E12 735 936	CAPILLARY TUBE				2	2	2	ø3.0xø1.8x600	
27	G	E12 838 704	DRAIN SOCKET		1		1		1		

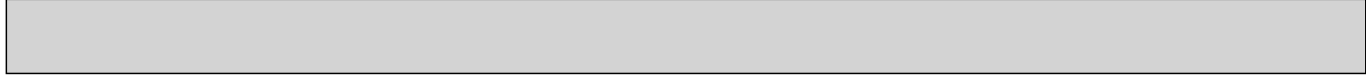

**MUZ-EF25VE MUZ-EF25VEH MUZ-EF35VE MUZ-EF35VEH MUZ-EF42VE**  
**1-2. OUTDOOR UNIT ELECTRICAL PARTS**

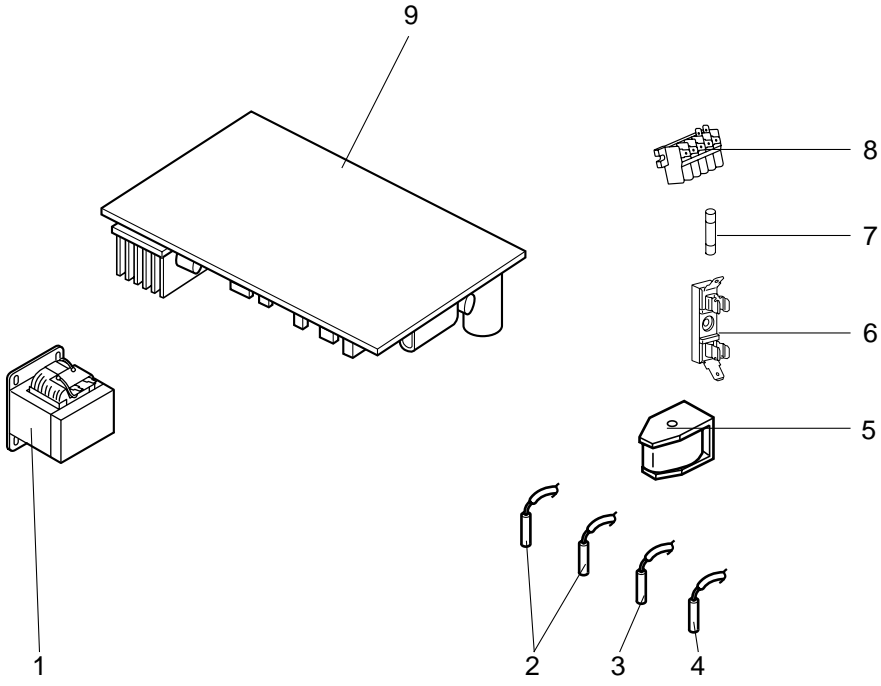

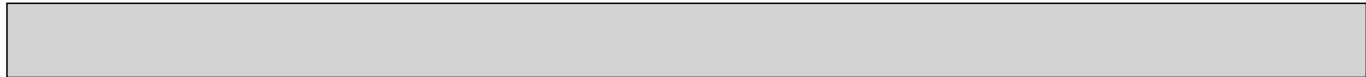

## 1-2. OUTDOOR UNIT ELECTRICAL PARTS

No.	RoHS	Part No.	Part Name	Symbol in Wiring Diagram	Q'ty/unit					Remarks
					MUZ-EF25		MUZ-EF35		MUZ-EF42	
					VE- [E1]	VEH-[E1]	VE- [E1]	VEH- [E1]	VE- [E1]	
1	G	E12 G10 337	REACTOR	L61	1	1				
	G	E12 G11 337					1	1	1	
2	G	E12 C34 306	THERMISTOR SET	RT61, RT62	1	1	1	1	1	DEFROST, DISCHARGE
3	G	E12 G10 309	AMBIENT TEMPERATURE THERMISTOR	RT65	1	1	1	1	1	
4	G	E12 C34 307	OUTDOOR HEAT EXCHANGER TEMPERATURE THERMISTOR	RT68	1	1	1	1	1	
5	G	E12 G10 490	R.V. COIL	21S4	1	1	1	1	1	
6	G	E12 735 241	FUSE HOLDER		1	1	1	1	1	
7	G	E12 735 382	FUSE	F61	1	1	1	1	1	T20AL250V
8	G	E12 G16 374	TERMINAL BLOCK	TB	1	1	1	1	1	5 P
9	G	E12 G10 451	INVERTER P.C. BOARD		1					Including heat sink and RT64
	G	E12 G13 451				1				
	G	E12 G11 451					1			
	G	E12 G14 451						1		
	G	E12 G12 451							1	

# MUZ-EF50VE

## 1-3. OUTDOOR UNIT STRUCTURAL PARTS, ELECTRICAL PARTS AND FUNCTIONAL PARTS

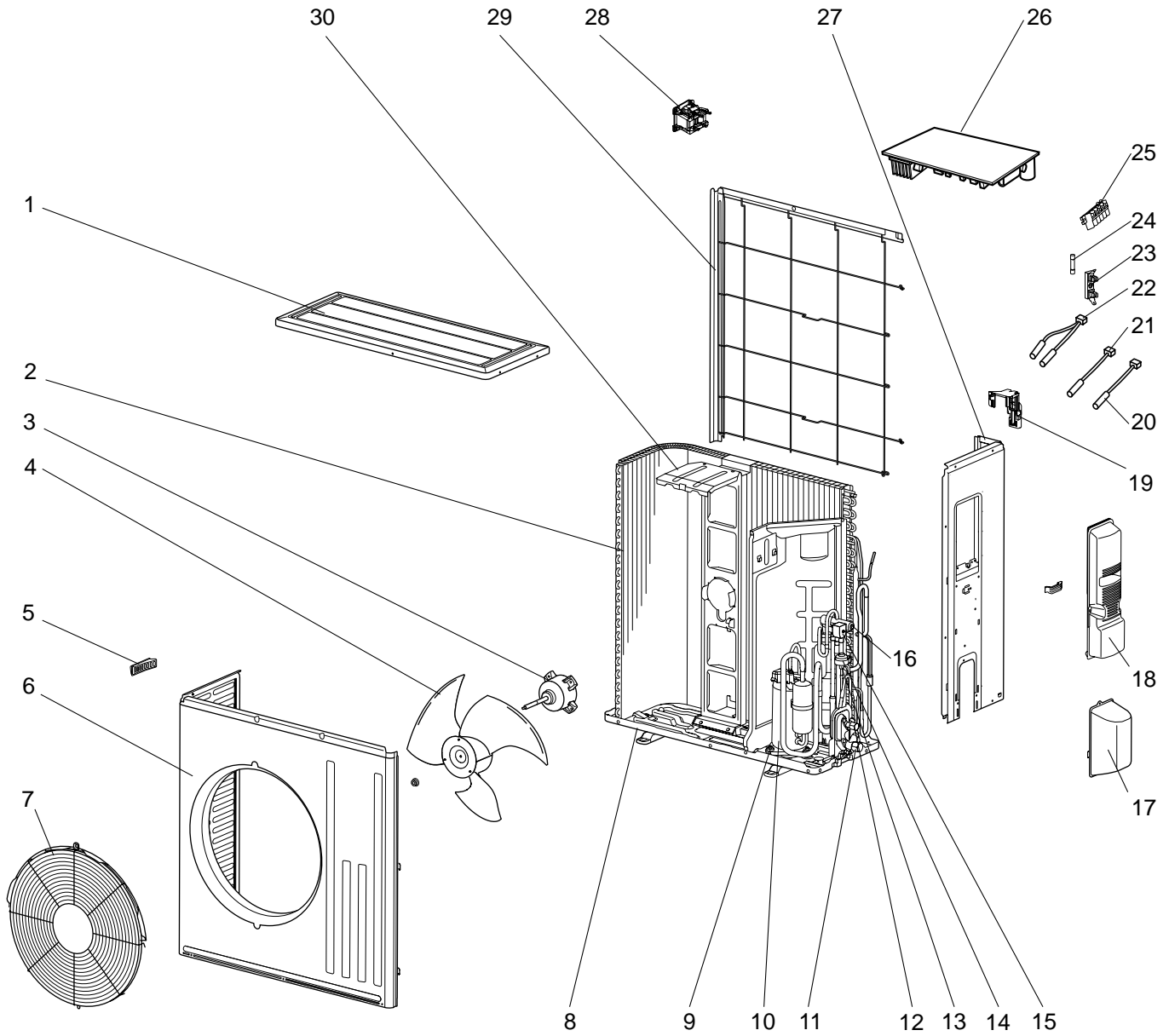

### 1-3. OUTDOOR UNIT STRUCTURAL PARTS, ELECTRICAL PARTS AND FUNCTIONAL PARTS

Part numbers that are circled are not shown in the illustration.

No.	RoHS	Part No.	Part Name	Symbol in Wiring Diagram	Q'ty/unit	Remarks
					MUZ-EF50VE- [E1]	
1	G	E12 F28 297	TOP PANEL		1	
2	G	E12 G16 630	OUTDOOR HEAT EXCHANGER		1	
3	G	E12 G16 301	OUTDOOR FAN MOTOR	MF	1	RC0J60-□□
4	G	E12 F28 501	PROPELLER		1	
5	G	E12 817 009	HANDLE		1	
6	G	E12 F35 232	CABINET		1	
7	G	E12 F73 521	FAN GUARD		1	Including ice guard
8	G	E12 F28 290	BASE		1	
9	G	E12 C34 506	COMPRESSOR RUBBER SET		3	3 RUBBERS/SET
10	G	E12 F28 900	COMPRESSOR	MC	1	SNB130FGBMT
11	G	E12 G16 661	STOP VALVE (GAS)		1	ø12.7
12	G	E12 G16 662	STOP VALVE (LIQUID)		1	ø6.35
13	G	E12 851 640	EXPANSION VALVE		1	
14	G	E12 F28 493	EXPANSION VALVE COIL	LEV	1	
15	G	E12 G16 490	R.V. COIL	21S4	1	
16	G	E12 C18 961	4-WAY VALVE		1	
17	G	E12 F28 650	VALVE COVER		1	
18	G	E12 F28 245	SERVICE PANEL		1	
19	G	E12 F28 079	THERMO HOLDER		1	
20	G	E12 G16 309	AMBIENT TEMPERATURE THERMISTOR	RT65	1	
21	G	E12 G16 307	OUTDOOR HEAT EXCHANGER TEMPERATURE THERMISTOR	RT68	1	
22	G	E12 G16 308	THERMISTOR SET	RT61,RT62	1	DEFROST, DISCHARGE
23	G	E12 735 241	FUSE HOLDER		1	
24	G	E12 735 382	FUSE	F61	1	T20AL250V
25	G	E12 G16 374	TERMINAL BLOCK	TB	1	5 P
26	G	E12 G16 451	INVERTER P.C. BOARD		1	Including heat sink and RT64
27	G	E12 F28 233	BACK PANEL (OUT)		1	
28	G	E12 D58 337	REACTOR	L61	1	
29	G	E12 F28 523	CONDENSER NET		1	
30	G	E12 F28 515	MOTOR SUPPORT		1	
31	G	E12 527 936	CAPILLARY TUBE		1	ø4.0 × ø2.4 × 100
32	G	E12 F28 704	DRAIN SOCKET		1	

## 2-1. DEFROST HEATER

Model	Parts No.
MUZ-EF42VE	MAC-643BH-E

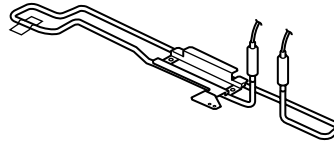

## Components

① Defrost heater	1	④ Cable tie	1	⑦ Wiring diagram	1
② Aluminum tape	1	⑤ Self drilling screw	2	⑧ Spec label	1
③ Heater support	1	⑥ Insulation	1		

Model	Parts No.
MUZ-EF50VE	MAC-644BH-E

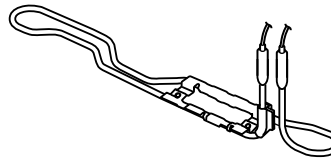

## Components

① Defrost heater	1	④ Cable clamp	1	⑦ Spec label	1
② Heater support	1	⑤ Self drilling screw	2		
③ Insulation	1	⑥ Wiring diagram	1		

## NOTE:

- Attaching the Freeze-prevention heater "MAC-643BH-E" (for drain pan) to MUZ-EF25/35VE requires installation of the INVERTER P.C. BOARD for MUZ-EF25/35VEH. Order the INVERTER P.C. BOARD for MUZ-EF25/35VEH as needed.
- Refer to the installation manual for the installation.