

# OUTDOOR UNIT SERVICE MANUAL



No. OBH635

## Models

**MUZ-GF60VE** - E1

**MUZ-GF71VE** - E1

Indoor unit service manual  
MSZ-GF•VE Series (OBH634)

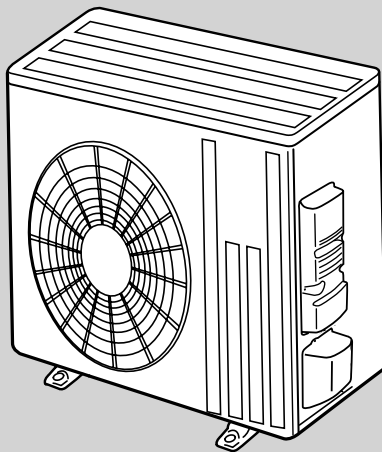

## CONTENTS

1. TECHNICAL CHANGES .....	3
2. PART NAMES AND FUNCTIONS .....	4
3. SPECIFICATION .....	5
4. NOISE CRITERIA CURVES .....	7
5. OUTLINES AND DIMENSIONS .....	8
6. WIRING DIAGRAM .....	9
7. REFRIGERANT SYSTEM DIAGRAM .....	10
8. PERFORMANCE CURVES .....	12
9. ACTUATOR CONTROL .....	21
10. SERVICE FUNCTIONS .....	22
11. TROUBLESHOOTING .....	22
12. DISASSEMBLY INSTRUCTIONS .....	39

**PARTS CATALOG (OBB635)**

**NOTE:**  
RoHS compliant products have <G> mark on the spec name plate.



## Use the specified refrigerant only

### **Never use any refrigerant other than that specified.**

Doing so may cause a burst, an explosion, or fire when the unit is being used, serviced, or disposed of.

Correct refrigerant is specified in the manuals and on the spec labels provided with our products.

We will not be held responsible for mechanical failure, system malfunction, unit breakdown or accidents caused by failure to follow the instructions.

### **<Preparation before the repair service>**

- Prepare the proper tools.
- Prepare the proper protectors.
- Provide adequate ventilation.
- After stopping the operation of the air conditioner, turn off the power-supply breaker and remove the power plug.
- Discharge the capacitor before the work involving the electric parts.

### **<Precautions during the repair service>**

- Do not perform the work involving the electric parts with wet hands.
- Do not pour water into the electric parts.
- Do not touch the refrigerant.
- Do not touch the hot or cold areas in the refrigeration cycle.
- When the repair or the inspection of the circuit needs to be done without turning off the power, exercise great caution not to touch the live parts.

**MUZ-GF60VE** -<sup>E1</sup>

**MUZ-GF71VE** -<sup>E1</sup>

1. New model

# 2

# PART NAMES AND FUNCTIONS

MUZ-GF60VE MUZ-GF71VE

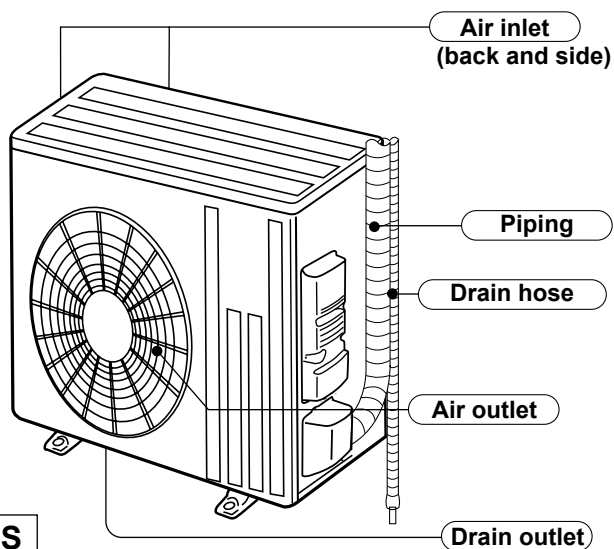

## ACCESSORIES

Model	MUZ-GF60/71VE
① Drain socket	1

# 3

# SPECIFICATION

Outdoor model				MUZ-GF60VE	MUZ-GF71VE	
Power supply				Single phase, 230 V, 50 Hz		
Capacity		Cooling	kW	6.1 (1.4 - 7.5)	7.1 (2.0 - 8.7)	
Rated frequency (Min. - Max.)		Heating		6.8 (2.0 - 9.3)	8.1 (2.2 - 9.9)	
Breaker Capacity			A	20		
Electrical data	Power input *1 (Total)		Cooling	1,790	2,130	
			Heating	1,810	2,230	
	Running current *1 (Total)		Cooling	7.9	9.3	
			Heating	8.0	9.8	
	Power factor *1 (Total)		Cooling	98	99	
			Heating	98	99	
Starting current *1 (Total)			A	8.0	9.8	
Coefficient of performance (COP) *1 (Total)		Cooling		3.41	3.33	
		Heating		3.76	3.63	
Compressor	Model			SNB130FGBMT	SNB172FEKMT	
	Output		W	900	1,200	
	Current *1	Cooling	A	6.58	8.00	
		Heating	A	6.54	8.47	
	Refrigeration oil (Model)			L	0.35(FV50S)	0.40(FV50S)
Fan motor	Model			RC0J60-BC		
	Current *1	Cooling	A	0.93	0.83	
		Heating	A	0.93	0.82	
Dimensions W × H × D			mm	840 × 880 × 330		
Weight			kg	50	53	
Special remarks	Dehumidification		Cooling	L/h	1.9	2.3
	Air flow *1	Cooling	High	m <sup>3</sup> /h	3,492	3,426
			Med.		3,066	3,006
			Low		1,692	1,512
		Heating	High		2,952	2,892
			Med.		2,952	2,892
			Low		2,226	2,280
	Sound level *1		Cooling	dB(A)	55	
			Heating	dB(A)	55	
	Fan speed	Cooling	High	rpm	950	
			Med.		840	
			Low		480	450
		Heating	High		810	
			Med.		810	
Low			620		650	
Fan speed regulator				3		
Refrigerant filling capacity (R410A)			kg	1.55	1.90	

**NOTE:** Test conditions are based on ISO 5151.

Cooling: Indoor Dry-bulb temperature 27°C

Wet-bulb temperature 19°C

Outdoor Dry-bulb temperature 35°C

Heating: Indoor Dry-bulb temperature 20°C

Wet-bulb temperature 6°C

Outdoor Dry-bulb temperature 7°C

Refrigerant piping length (one way): 5 m

\*1 Measured under rated operating frequency.



**Specifications and rated conditions of main electric parts**

Item		Model	MUZ-GF60VE	MUZ-GF71VE
Smoothing capacitor		(CB1, CB2, CB3)	560 $\mu$ F 450 V	
Fuse		(F601, F880, F901)	T3.15AL250 V	
IGBT module		(IC932)	5 A 600 V	
		(IC700)	20 A 600 V	
Expansion valve coil		(LEV)	12 V DC	
Reactor		(L)	340 $\mu$ H	
Diode module		(IC820)	20 A 600 V	
Circuit protection		(PTC64, PTC65)	33 $\Omega$	
Terminal block		(TB1, TB2)	3 P	
Relay		(X64)	20 A 250 V	
		(X65)	20 A 250 V	
		(X69)	10 A 250 V	
		(X601)	3 A 250 V	
		(X602)	3 A 250 V	
R.V. coil		(21S4)	220 - 240 V AC	

# 4

# NOISE CRITERIA CURVES

## MUZ-GF60VE

FUNCTION	SPL(dB(A))	LINE
COOLING	55	●—●
HEATING	55	○—○

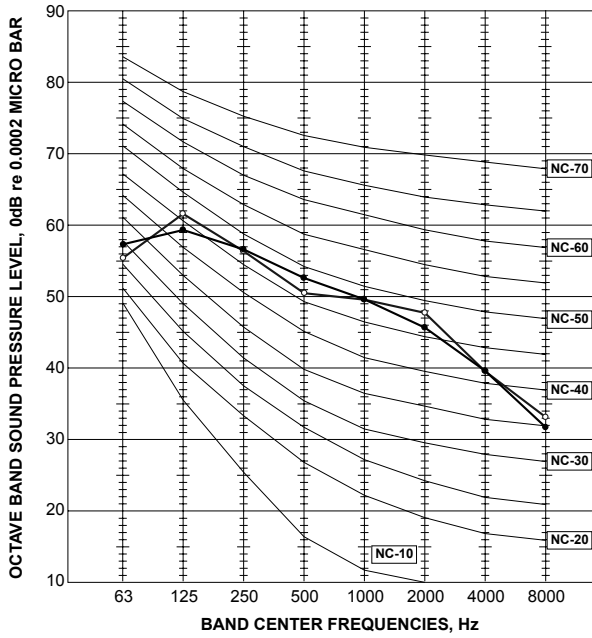

## MUZ-GF71VE

FUNCTION	SPL(dB(A))	LINE
COOLING	55	●—●
HEATING	55	○—○

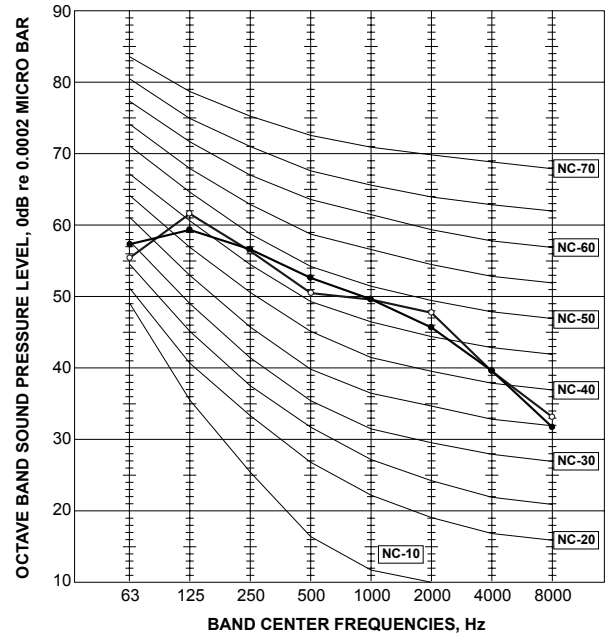

### Test conditions

Cooling: Dry-bulb temperature 35°C

Heating: Dry-bulb temperature 7°C Wet-bulb temperature 6°C

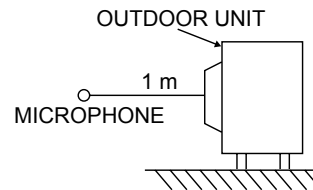

5

OUTLINES AND DIMENSIONS

MUZ-GF60VE MUZ-GF71VE

Unit: mm

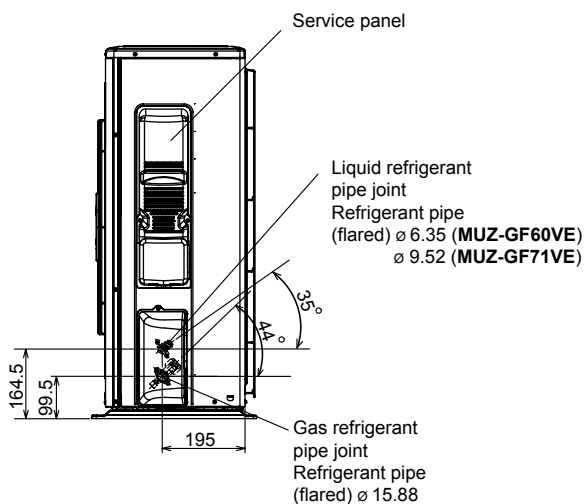
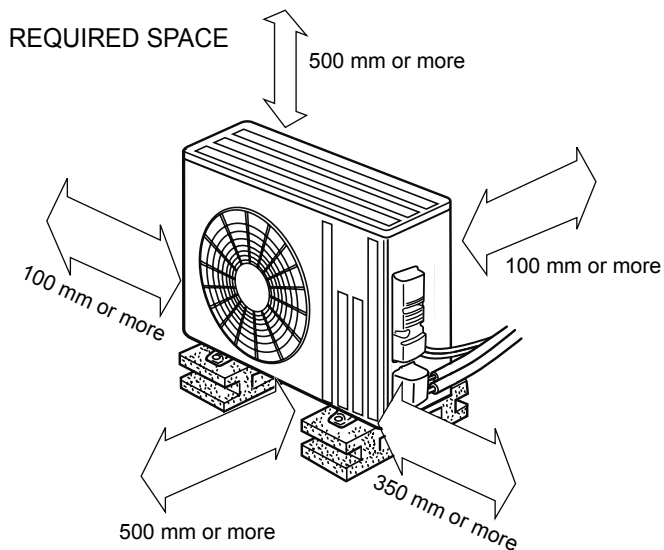
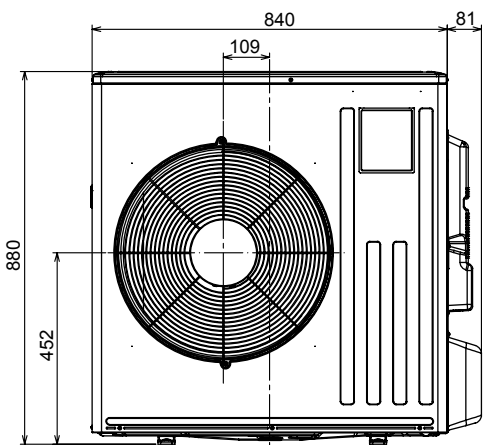
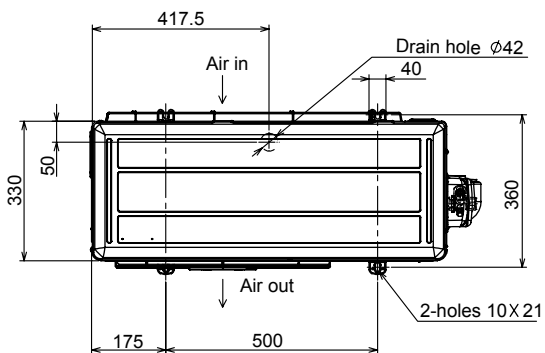



# 6

# WIRING DIAGRAM

## MUZ-GF60VE MUZ-GF71VE

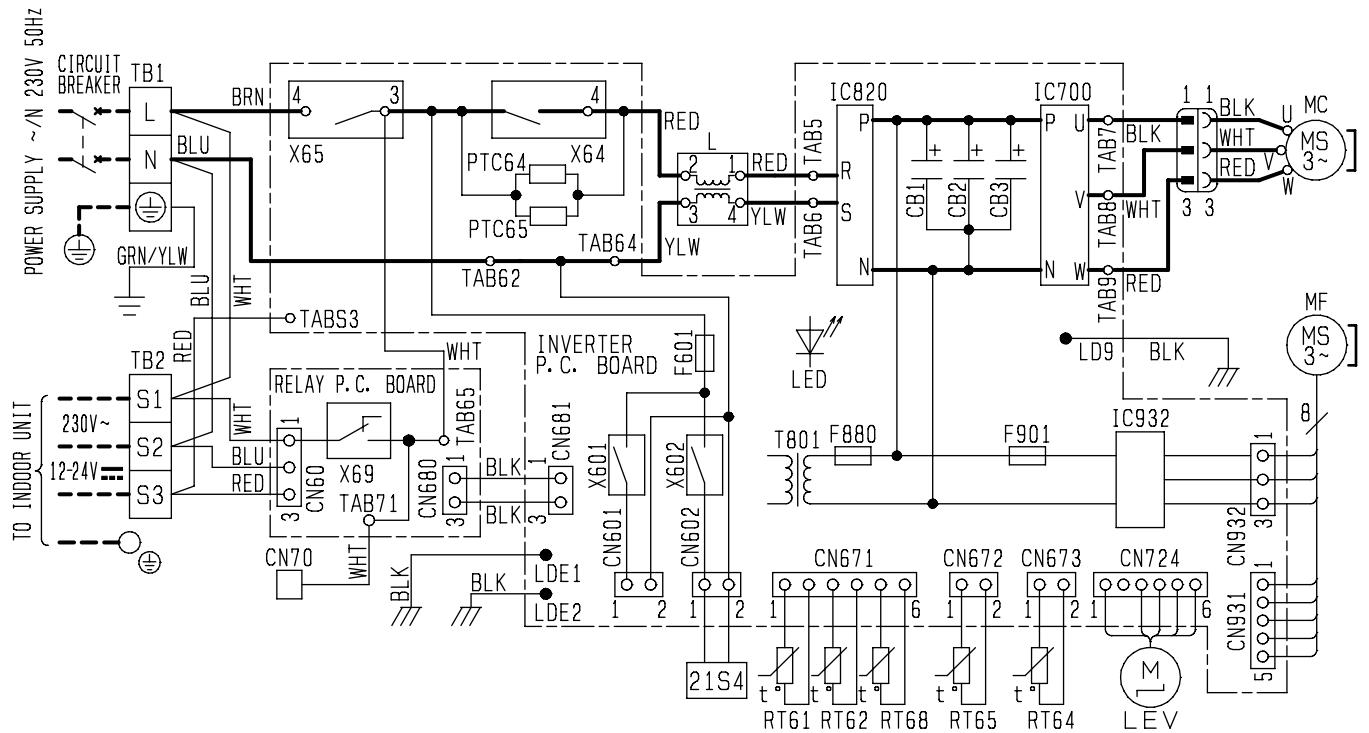

SYMBOL	NAME	SYMBOL	NAME	SYMBOL	NAME	SYMBOL	NAME
CB1 ~ 3	SMOOTHING CAPACITOR	L	REACTOR	RT62	DISCHARGE TEMP. THERMISTOR	X602	RELAY
CN70	CONNECTOR	LED	LED	RT64	FIN TEMP. THERMISTOR	X64	RELAY
F601	FUSE (T3. 15A/250V)	LEV	EXPANSION VALVE COIL	RT65	AMBIENT TEMP. THERMISTOR	X65	RELAY
F880	FUSE (T3. 15A/250V)	MC	COMPRESSOR	RT68	OUTDOOR HEAT EXCHANGER TEMP. THERMISTOR	X69	RELAY
F901	FUSE (T3. 15A/250V)	MF	FAN MOTOR	21S4	REVERSING VALVE SOLENOID COIL		
IC700	IGBT Module	PTC64	CIRCUIT PROTECTION	TB1, TB2	TERMINAL BLOCK		
IC820	DIODE Module	PTC65	CIRCUIT PROTECTION	T801	TRANSFORMER		
IC932	IGBT Module	RT61	DEFROST THERMISTOR	X601	RELAY		

NOTES 1. About the indoor side electric wiring, refer to the indoor unit electric wiring diagram for servicing.  
 2. Use copper conductors only (for field wiring). 3. Symbols indicate,  : Terminal block

MUZ-GF60VE

Unit: mm

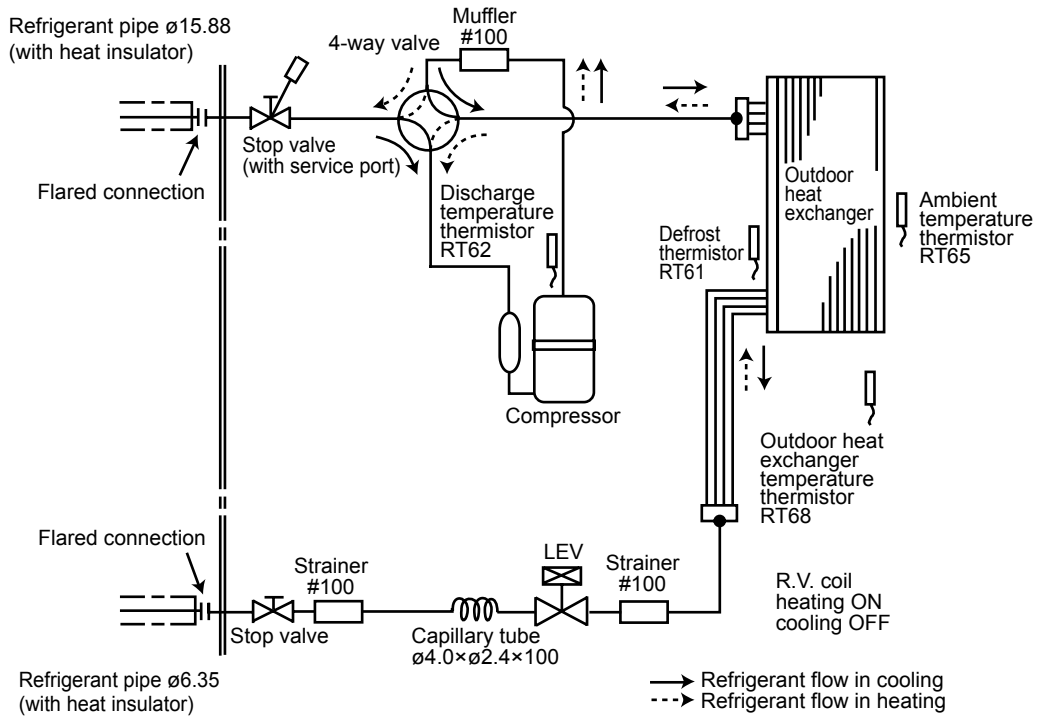

MUZ-GF71VE

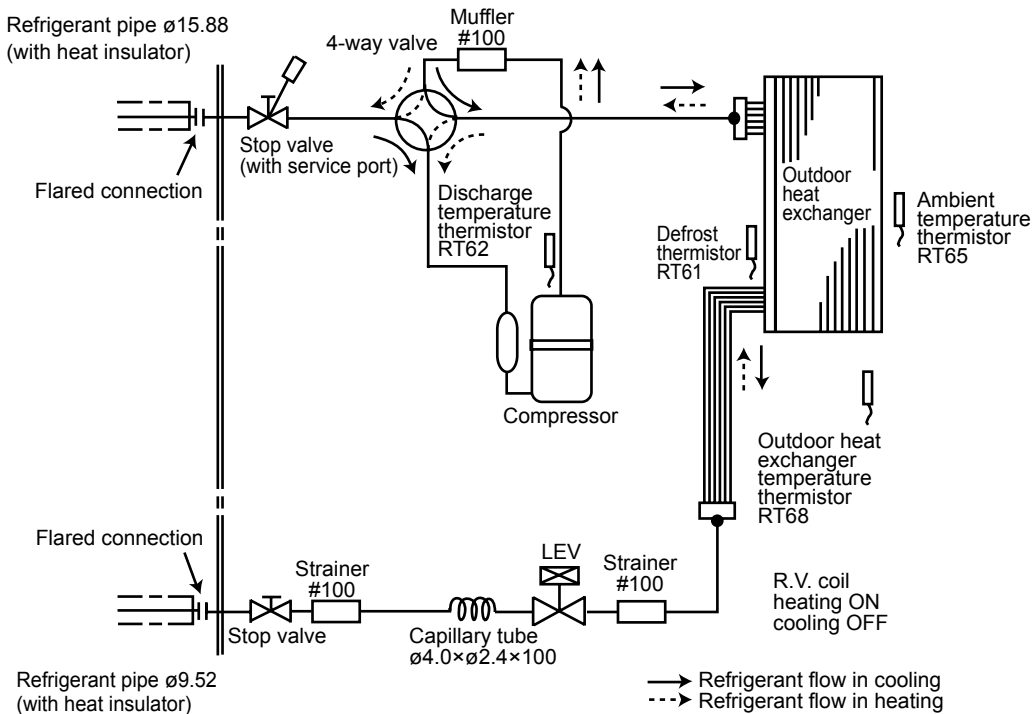

Unit: mm

### MAX. REFRIGERANT PIPING LENGTH and MAX. HEIGHT DIFFERENCE

	Refrigerant piping: m		Piping size O.D: mm	
	Max. Length A	Max. Height difference B	Gas	Liquid
<b>MUZ-GF60</b>	30	15	15.88	6.35
<b>MUZ-GF71</b>				9.52

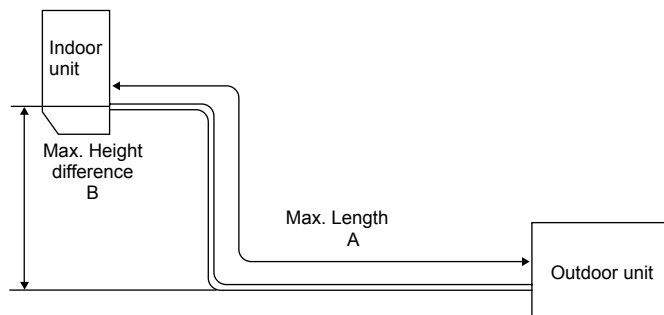

### ADDITIONAL REFRIGERANT CHARGE (R410A: g)

Model	Outdoor unit precharged	Refrigerant piping length (one way)					
		7 m	10 m	15 m	20 m	25 m	30 m
<b>MUZ-GF60</b>	1,550	0	0	100	200	300	400

Calculation: X g = 20 g/m × (Refrigerant piping length (m) – 10)

Model	Outdoor unit precharged	Refrigerant piping length (one way)					
		7 m	10 m	15 m	20 m	25 m	30 m
<b>MUZ-GF71</b>	1,900	0	0	275	550	825	1,100

Calculation: X g = 55 g/m × (Refrigerant piping length (m) – 10)

**NOTE:** Refrigerant piping exceeding 7 m requires additional refrigerant charge according to the calculation.

## MUZ-GF60VE MUZ-GF71VE

The standard specifications apply only to the operation of the air conditioner under normal conditions. Since operating conditions vary according to the areas where these units are installed, the following information has been provided to clarify the operating characteristics of the air conditioner under the conditions indicated by the performance curve.

### (1) GUARANTEED VOLTAGE

198 ~ 264 V, 50 Hz

### (2) AIR FLOW

Air flow should be set at MAX.

### (3) MAIN READINGS

(1) Indoor intake air wet-bulb temperature:	°C [WB]	} Cooling
(2) Indoor outlet air wet-bulb temperature:	°C [WB]	
(3) Outdoor intake air dry-bulb temperature:	°C [DB]	
(4) Total input:	W	
(5) Indoor intake air dry-bulb temperature:	°C [DB]	} Heating
(6) Outdoor intake air wet-bulb temperature:	°C [WB]	
(7) Total input:	W	

Indoor air wet and dry bulb temperature difference on the left side of the following chart shows the difference between the indoor intake air wet and dry bulb temperature and the indoor outlet air wet and dry bulb temperature for your reference at service.

### How to measure the indoor air wet and dry bulb temperature difference

- Attach at least 2 sets of wet and dry bulb thermometers to the indoor air intake as shown in the figure, and at least 2 sets of wet and dry bulb thermometers to the indoor air outlet. The thermometers must be attached to the position where air speed is high.
- Attach at least 2 sets of wet and dry bulb thermometers to the outdoor air intake.  
Cover the thermometers to prevent direct rays of the sun.
- Check that the air filter is cleaned.
- Open windows and doors of room.
- Press the EMERGENCY OPERATION switch once (twice) to start the EMERGENCY COOL (HEAT) MODE.
- When system stabilizes after more than 15 minutes, measure temperature and take an average temperature.
- 10 minutes later, measure temperature again and check that the temperature does not change.

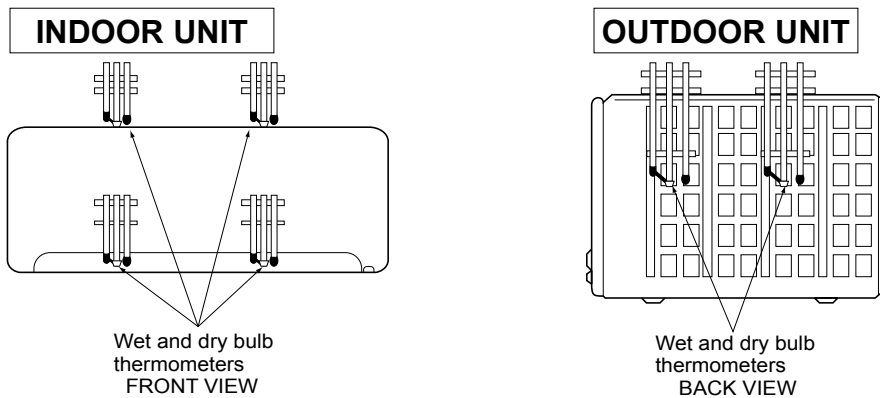

### 8-1. CAPACITY AND INPUT CURVES

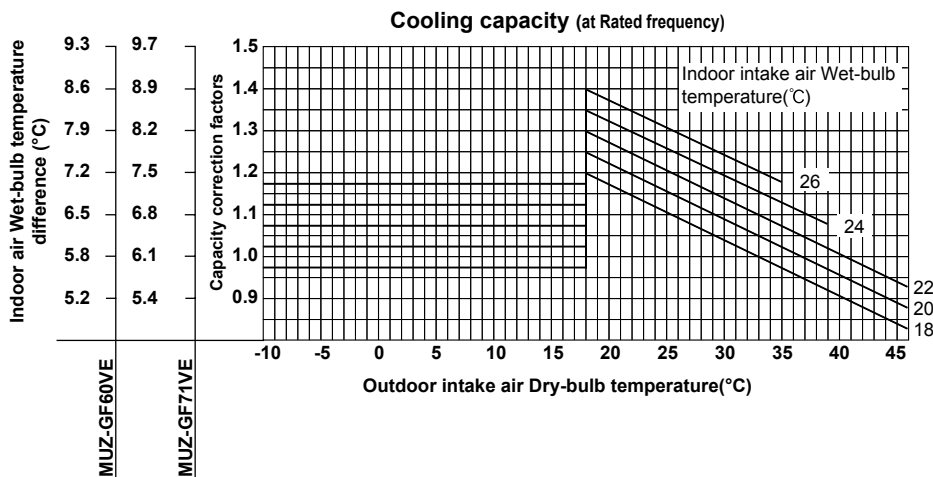

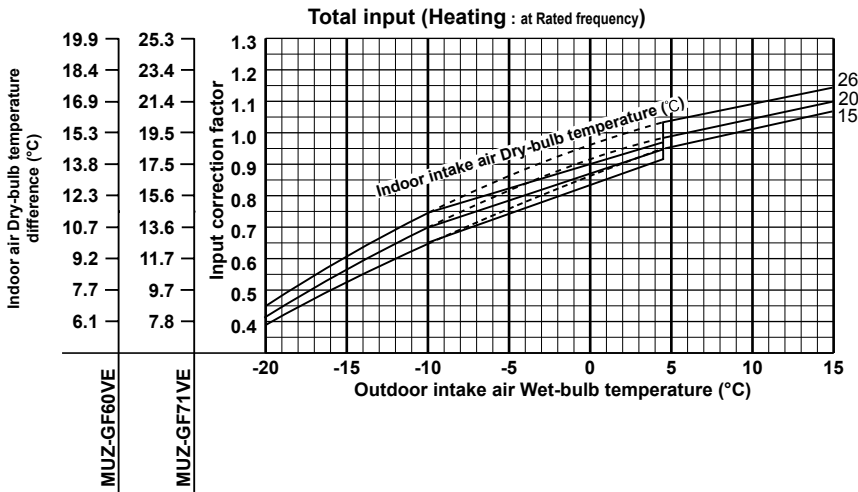
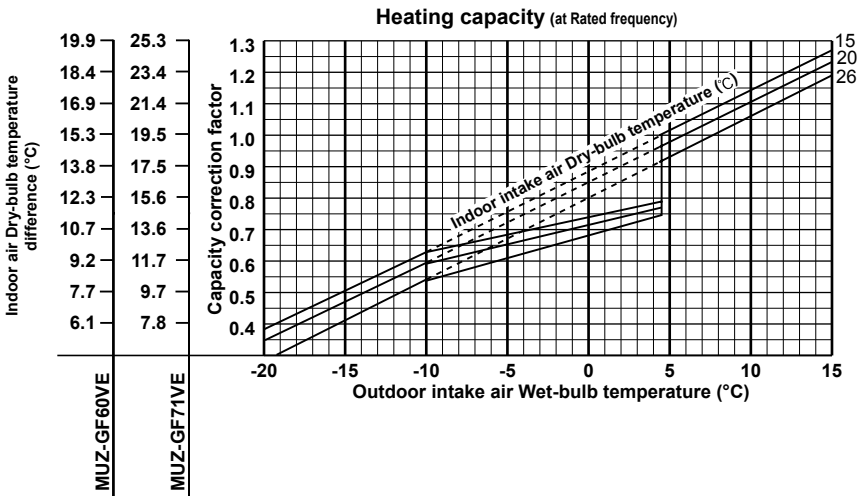
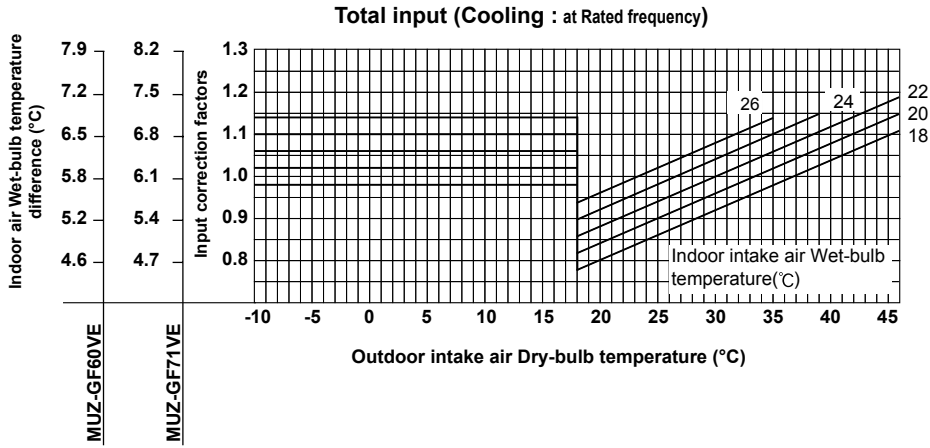

**NOTE:** The above broken lines are for the heating operation without any frost and defrost operation.

## 8-2. CAPACITY AND INPUT CORRECTION BY OPERATIONAL FREQUENCY OF COMPRESSOR

### MUZ-GF60VE

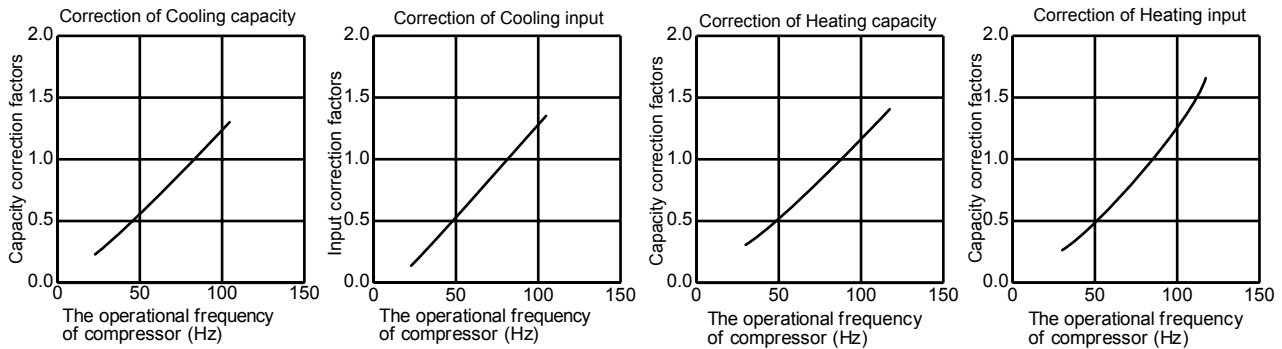

### MUZ-GF71VE

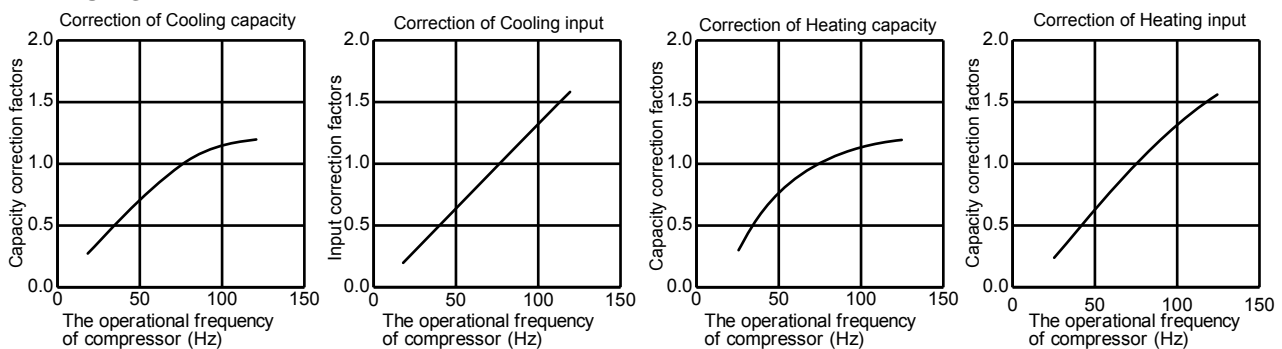

## 8-3. HOW TO OPERATE FIXED-FREQUENCY OPERATION

<Test run operation>

1. Press EMERGENCY OPERATION switch to start COOL or HEAT mode (COOL: Press once, HEAT: Press twice).
2. Test run operation starts and continues to operate for 30 minutes.
3. Compressor operates at rated frequency in COOL mode or 58 Hz (**MUZ-GF60VE**)/74 Hz (**MUZ-GF71VE**) in HEAT mode.
4. Indoor fan operates at High speed.
5. After 30 minutes, test run operation finishes and EMERGENCY OPERATION starts (operation frequency of compressor varies).
6. To cancel test run operation (EMERGENCY OPERATION), press EMERGENCY OPERATION switch or any button on remote controller.

## 8-4. OUTDOOR LOW PRESSURE AND OUTDOOR UNIT CURRENT

### COOL operation

- ① Both indoor and outdoor unit are under the same temperature/humidity condition.
- ② Operation: TEST RUN OPERATION (Refer to 8-3.)

Dry-bulb temperature (°C)	Relative humidity (%)
20	50
25	60
30	70

### MUZ-GF60VE

### MUZ-GF71VE

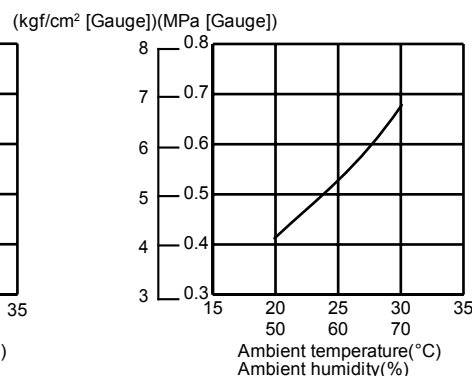
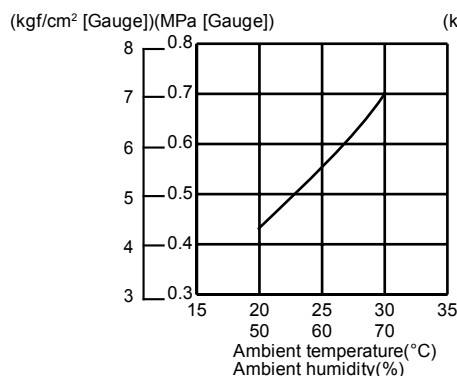

### NOTE:

The unit of pressure has been changed to MPa on the international system of units (SI unit system)  
The conversion factor is: **1 (MPa [Gauge]) = 10.2 (kgf/cm<sup>2</sup> [Gauge])**

## Outdoor unit current

### MUZ-GF60VE

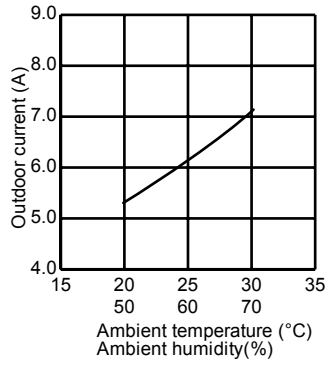

### MUZ-GF71VE

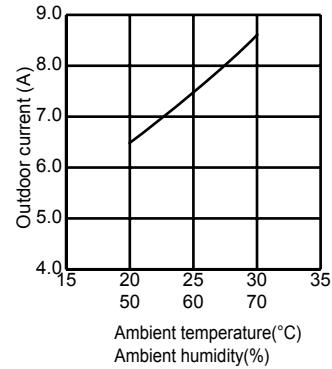

## HEAT operation

① Condition:

	Indoor	Outdoor			
		2	7	15	20.0
Dry bulb temperature (°C)	20.0	2	7	15	20.0
Wet bulb temperature (°C)	14.5	1	6	12	14.5

② Operation: Test run operation (Refer to 8-3.)

## Outdoor unit current

### MUZ-GF60VE

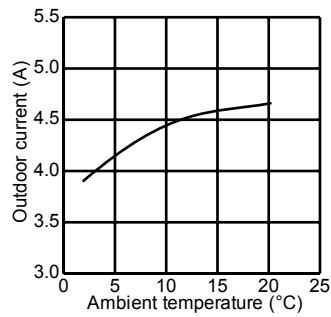

### MUZ-GF71VE

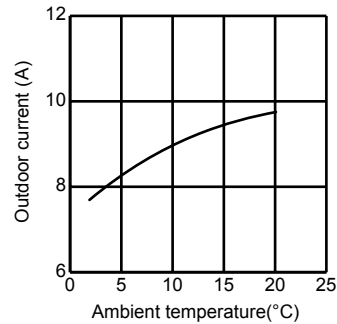

**PERFORMANCE DATA COOL operation at Rated frequency**

**MUZ-GF60VE**

CAPACITY: 6.1 kW

SHF: 0.79

INPUT: 1790 W

INDOOR DB (°C)	INDOOR WB (°C)	OUTDOOR DB (°C)															
		21				25				27				30			
		Q	SHC	SHF	INPUT	Q	SHC	SHF	INPUT	Q	SHC	SHF	INPUT	Q	SHC	SHF	INPUT
21	18	7.17	4.37	0.61	1432	6.86	4.19	0.61	1504	6.59	4.02	0.61	1575	6.34	3.87	0.61	1647
21	20	7.47	3.66	0.49	1504	7.17	3.51	0.49	1593	6.95	3.41	0.49	1629	6.71	3.29	0.49	1701
22	18	7.17	4.66	0.65	1432	6.86	4.46	0.65	1504	6.59	4.28	0.65	1575	6.34	4.12	0.65	1647
22	20	7.47	3.96	0.53	1504	7.17	3.80	0.53	1593	6.95	3.69	0.53	1629	6.71	3.56	0.53	1701
22	22	7.78	3.19	0.41	1557	7.50	3.08	0.41	1656	7.32	3.00	0.41	1701	7.01	2.88	0.41	1772
23	18	7.17	4.95	0.69	1432	6.86	4.74	0.69	1504	6.59	4.55	0.69	1575	6.34	4.38	0.69	1647
23	20	7.47	4.26	0.57	1504	7.17	4.09	0.57	1593	6.95	3.96	0.57	1629	6.71	3.82	0.57	1701
23	22	7.78	3.50	0.45	1557	7.50	3.38	0.45	1656	7.32	3.29	0.45	1701	7.01	3.16	0.45	1772
24	18	7.17	5.23	0.73	1432	6.86	5.01	0.73	1504	6.59	4.81	0.73	1575	6.34	4.63	0.73	1647
24	20	7.47	4.56	0.61	1504	7.17	4.37	0.61	1593	6.95	4.24	0.61	1629	6.71	4.09	0.61	1701
24	22	7.78	3.81	0.49	1557	7.50	3.68	0.49	1656	7.32	3.59	0.49	1701	7.01	3.44	0.49	1772
24	24	8.17	3.02	0.37	1629	7.87	2.91	0.37	1718	7.69	2.84	0.37	1772	7.44	2.75	0.37	1862
25	18	7.17	5.52	0.77	1432	6.86	5.28	0.77	1504	6.59	5.07	0.77	1575	6.34	4.88	0.77	1647
25	20	7.47	4.86	0.65	1504	7.17	4.66	0.65	1593	6.95	4.52	0.65	1629	6.71	4.36	0.65	1701
25	22	7.78	4.12	0.53	1557	7.50	3.98	0.53	1656	7.32	3.88	0.53	1701	7.01	3.72	0.53	1772
25	24	8.17	3.35	0.41	1629	7.87	3.23	0.41	1718	7.69	3.15	0.41	1772	7.44	3.05	0.41	1862
26	18	7.17	5.81	0.81	1432	6.86	5.56	0.81	1504	6.59	5.34	0.81	1575	6.34	5.14	0.81	1647
26	20	7.47	5.16	0.69	1504	7.17	4.95	0.69	1593	6.95	4.80	0.69	1629	6.71	4.63	0.69	1701
26	22	7.78	4.43	0.57	1557	7.50	4.28	0.57	1656	7.32	4.17	0.57	1701	7.01	4.00	0.57	1772
26	24	8.17	3.68	0.45	1629	7.87	3.54	0.45	1718	7.69	3.46	0.45	1772	7.44	3.35	0.45	1862
26	26	8.42	2.78	0.33	1718	8.17	2.70	0.33	1808	8.05	2.66	0.33	1862	7.81	2.58	0.33	1915
27	18	7.17	6.09	0.85	1432	6.86	5.83	0.85	1504	6.59	5.60	0.85	1575	6.34	5.39	0.85	1647
27	20	7.47	5.45	0.73	1504	7.17	5.23	0.73	1593	6.95	5.08	0.73	1629	6.71	4.90	0.73	1701
27	22	7.78	4.74	0.61	1557	7.50	4.58	0.61	1656	7.32	4.47	0.61	1701	7.01	4.28	0.61	1772
27	24	8.17	4.01	0.49	1629	7.87	3.86	0.49	1718	7.69	3.77	0.49	1772	7.44	3.65	0.49	1862
27	26	8.42	3.11	0.37	1718	8.17	3.02	0.37	1808	8.05	2.98	0.37	1862	7.81	2.89	0.37	1915
28	18	7.17	6.38	0.89	1432	6.86	6.11	0.89	1504	6.59	5.86	0.89	1575	6.34	5.65	0.89	1647
28	20	7.47	5.75	0.77	1504	7.17	5.52	0.77	1593	6.95	5.35	0.77	1629	6.71	5.17	0.77	1701
28	22	7.78	5.06	0.65	1557	7.50	4.88	0.65	1656	7.32	4.76	0.65	1701	7.01	4.56	0.65	1772
28	24	8.17	4.33	0.53	1629	7.87	4.17	0.53	1718	7.69	4.07	0.53	1772	7.44	3.94	0.53	1862
28	26	8.42	3.45	0.41	1718	8.17	3.35	0.41	1808	8.05	3.30	0.41	1862	7.81	3.20	0.41	1915
29	18	7.17	6.67	0.93	1432	6.86	6.38	0.93	1504	6.59	6.13	0.93	1575	6.34	5.90	0.93	1647
29	20	7.47	6.05	0.81	1504	7.17	5.81	0.81	1593	6.95	5.63	0.81	1629	6.71	5.44	0.81	1701
29	22	7.78	5.37	0.69	1557	7.50	5.18	0.69	1656	7.32	5.05	0.69	1701	7.01	4.84	0.69	1772
29	24	8.17	4.66	0.57	1629	7.87	4.49	0.57	1718	7.69	4.38	0.57	1772	7.44	4.24	0.57	1862
29	26	8.42	3.79	0.45	1718	8.17	3.68	0.45	1808	8.05	3.62	0.45	1862	7.81	3.51	0.45	1915
30	18	7.17	6.95	0.97	1432	6.86	6.66	0.97	1504	6.59	6.39	0.97	1575	6.34	6.15	0.97	1647
30	20	7.47	6.35	0.85	1504	7.17	6.09	0.85	1593	6.95	5.91	0.85	1629	6.71	5.70	0.85	1701
30	22	7.78	5.68	0.73	1557	7.50	5.48	0.73	1656	7.32	5.34	0.73	1701	7.01	5.12	0.73	1772
30	24	8.17	4.99	0.61	1629	7.87	4.80	0.61	1718	7.69	4.69	0.61	1772	7.44	4.54	0.61	1862
30	26	8.42	4.12	0.49	1718	8.17	4.01	0.49	1808	8.05	3.95	0.49	1862	7.81	3.83	0.49	1915
31	18	7.17	7.17	1.00	1432	6.86	6.86	1.00	1504	6.59	6.59	1.00	1575	6.34	6.34	1.00	1647
31	20	7.47	6.65	0.89	1504	7.17	6.38	0.89	1593	6.95	6.19	0.89	1629	6.71	5.97	0.89	1701
31	22	7.78	5.99	0.77	1557	7.50	5.78	0.77	1656	7.32	5.64	0.77	1701	7.01	5.40	0.77	1772
31	24	8.17	5.31	0.65	1629	7.87	5.11	0.65	1718	7.69	5.00	0.65	1772	7.44	4.84	0.65	1862
31	26	8.42	4.46	0.53	1718	8.17	4.33	0.53	1808	8.05	4.27	0.53	1862	7.81	4.14	0.53	1915
32	18	7.17	7.17	1.00	1432	6.86	6.86	1.00	1504	6.59	6.59	1.00	1575	6.34	6.34	1.00	1647
32	20	7.47	6.95	0.93	1504	7.17	6.67	0.93	1593	6.95	6.47	0.93	1629	6.71	6.24	0.93	1701
32	22	7.78	6.30	0.81	1557	7.50	6.08	0.81	1656	7.32	5.93	0.81	1701	7.01	5.68	0.81	1772
32	24	8.17	5.64	0.69	1629	7.87	5.43	0.69	1718	7.69	5.30	0.69	1772	7.44	5.13	0.69	1862
32	26	8.42	4.80	0.57	1718	8.17	4.66	0.57	1808	8.05	4.59	0.57	1862	7.81	4.45	0.57	1915

**NOTE** Q : Total capacity (kW) SHF : Sensible heat factor DB : Dry-bulb temperature  
 SHC : Sensible heat capacity (kW) INPUT : Total power input (W) WB : Wet-bulb temperature



**PERFORMANCE DATA COOL operation at Rated frequency**

**MUZ-GF60VE**

CAPACITY: 6.1 kW

SHF: 0.79

INPUT: 1790 W

INDOOR DB (°C)	INDOOR WB (°C)	OUTDOOR DB (°C)											
		35				40				46			
		Q	SHC	SHF	INPUT	Q	SHC	SHF	INPUT	Q	SHC	SHF	INPUT
21	18	5.98	3.65	0.61	1754	5.49	3.35	0.61	1862	5.06	3.09	0.61	1933
21	20	6.28	3.08	0.49	1826	5.86	2.87	0.49	1915	5.43	2.66	0.49	2023
22	18	5.98	3.89	0.65	1754	5.49	3.57	0.65	1862	5.06	3.29	0.65	1933
22	20	6.28	3.33	0.53	1826	5.86	3.10	0.53	1915	5.43	2.88	0.53	2023
22	22	6.65	2.73	0.41	1897	6.22	2.55	0.41	2005	5.79	2.38	0.41	2076
23	18	5.98	4.12	0.69	1754	5.49	3.79	0.69	1862	5.06	3.49	0.69	1933
23	20	6.28	3.58	0.57	1826	5.86	3.34	0.57	1915	5.43	3.09	0.57	2023
23	22	6.65	2.99	0.45	1897	6.22	2.80	0.45	2005	5.79	2.61	0.45	2076
24	18	5.98	4.36	0.73	1754	5.49	4.01	0.73	1862	5.06	3.70	0.73	1933
24	20	6.28	3.83	0.61	1826	5.86	3.57	0.61	1915	5.43	3.31	0.61	2023
24	22	6.65	3.26	0.49	1897	6.22	3.05	0.49	2005	5.79	2.84	0.49	2076
24	24	7.01	2.60	0.37	1969	6.59	2.44	0.37	2059	6.22	2.30	0.37	2148
25	18	5.98	4.60	0.77	1754	5.49	4.23	0.77	1862	5.06	3.90	0.77	1933
25	20	6.28	4.08	0.65	1826	5.86	3.81	0.65	1915	5.43	3.53	0.65	2023
25	22	6.65	3.52	0.53	1897	6.22	3.30	0.53	2005	5.79	3.07	0.53	2076
25	24	7.01	2.88	0.41	1969	6.59	2.70	0.41	2059	6.22	2.55	0.41	2148
26	18	5.98	4.84	0.81	1754	5.49	4.45	0.81	1862	5.06	4.10	0.81	1933
26	20	6.28	4.34	0.69	1826	5.86	4.04	0.69	1915	5.43	3.75	0.69	2023
26	22	6.65	3.79	0.57	1897	6.22	3.55	0.57	2005	5.79	3.30	0.57	2076
26	24	7.01	3.16	0.45	1969	6.59	2.96	0.45	2059	6.22	2.80	0.45	2148
26	26	7.38	2.44	0.33	2041	6.95	2.29	0.33	2130	6.53	2.15	0.33	2220
27	18	5.98	5.08	0.85	1754	5.49	4.67	0.85	1862	5.06	4.30	0.85	1933
27	20	6.28	4.59	0.73	1826	5.86	4.27	0.73	1915	5.43	3.96	0.73	2023
27	22	6.65	4.06	0.61	1897	6.22	3.80	0.61	2005	5.79	3.53	0.61	2076
27	24	7.01	3.44	0.49	1969	6.59	3.23	0.49	2059	6.22	3.05	0.49	2148
27	26	7.38	2.73	0.37	2041	6.95	2.57	0.37	2130	6.53	2.41	0.37	2220
28	18	5.98	5.32	0.89	1754	5.49	4.89	0.89	1862	5.06	4.51	0.89	1933
28	20	6.28	4.84	0.77	1826	5.86	4.51	0.77	1915	5.43	4.18	0.77	2023
28	22	6.65	4.32	0.65	1897	6.22	4.04	0.65	2005	5.79	3.77	0.65	2076
28	24	7.01	3.72	0.53	1969	6.59	3.49	0.53	2059	6.22	3.30	0.53	2148
28	26	7.38	3.03	0.41	2041	6.95	2.85	0.41	2130	6.53	2.68	0.41	2220
29	18	5.98	5.56	0.93	1754	5.49	5.11	0.93	1862	5.06	4.71	0.93	1933
29	20	6.28	5.09	0.81	1826	5.86	4.74	0.81	1915	5.43	4.40	0.81	2023
29	22	6.65	4.59	0.69	1897	6.22	4.29	0.69	2005	5.79	4.00	0.69	2076
29	24	7.01	4.00	0.57	1969	6.59	3.76	0.57	2059	6.22	3.55	0.57	2148
29	26	7.38	3.32	0.45	2041	6.95	3.13	0.45	2130	6.53	2.94	0.45	2220
30	18	5.98	5.80	0.97	1754	5.49	5.33	0.97	1862	5.06	4.91	0.97	1933
30	20	6.28	5.34	0.85	1826	5.86	4.98	0.85	1915	5.43	4.61	0.85	2023
30	22	6.65	4.85	0.73	1897	6.22	4.54	0.73	2005	5.79	4.23	0.73	2076
30	24	7.01	4.28	0.61	1969	6.59	4.02	0.61	2059	6.22	3.80	0.61	2148
30	26	7.38	3.62	0.49	2041	6.95	3.41	0.49	2130	6.53	3.20	0.49	2220
31	18	5.98	5.98	1.00	1754	5.49	5.49	1.00	1862	5.06	5.06	1.00	1933
31	20	6.28	5.59	0.89	1826	5.86	5.21	0.89	1915	5.43	4.83	0.89	2023
31	22	6.65	5.12	0.77	1897	6.22	4.79	0.77	2005	5.79	4.46	0.77	2076
31	24	7.01	4.56	0.65	1969	6.59	4.28	0.65	2059	6.22	4.04	0.65	2148
31	26	7.38	3.91	0.53	2041	6.95	3.69	0.53	2130	6.53	3.46	0.53	2220
32	18	5.98	5.98	1.00	1754	5.49	5.49	1.00	1862	5.06	5.06	1.00	1933
32	20	6.28	5.84	0.93	1826	5.86	5.45	0.93	1915	5.43	5.05	0.93	2023
32	22	6.65	5.39	0.81	1897	6.22	5.04	0.81	2005	5.79	4.69	0.81	2076
32	24	7.01	4.84	0.69	1969	6.59	4.55	0.69	2059	6.22	4.29	0.69	2148
32	26	7.38	4.21	0.57	2041	6.95	3.96	0.57	2130	6.53	3.72	0.57	2220

**NOTE** Q : Total capacity (kW) SHF : Sensible heat factor DB : Dry-bulb temperature  
 SHC : Sensible heat capacity (kW) INPUT : Total power input (W) WB : Wet-bulb temperature

**PERFORMANCE DATA COOL operation at Rated frequency**

**MUZ-GF71VE**

CAPACITY: 7.1 kW

SHF: 0.78

INPUT: 2130 W

INDOOR DB (°C)	INDOOR WB (°C)	OUTDOOR DB (°C)															
		21				25				27				30			
		Q	SHC	SHF	INPUT	Q	SHC	SHF	INPUT	Q	SHC	SHF	INPUT	Q	SHC	SHF	INPUT
21	18	8.34	5.01	0.60	1704	7.99	4.79	0.60	1789	7.67	4.60	0.60	1874	7.38	4.43	0.60	1960
21	20	8.70	4.17	0.48	1789	8.34	4.00	0.48	1896	8.09	3.89	0.48	1938	7.81	3.75	0.48	2024
22	18	8.34	5.34	0.64	1704	7.99	5.11	0.64	1789	7.67	4.91	0.64	1874	7.38	4.73	0.64	1960
22	20	8.70	4.52	0.52	1789	8.34	4.34	0.52	1896	8.09	4.21	0.52	1938	7.81	4.06	0.52	2024
22	22	9.05	3.62	0.40	1853	8.73	3.49	0.40	1970	8.52	3.41	0.40	2024	8.17	3.27	0.40	2109
23	18	8.34	5.67	0.68	1704	7.99	5.43	0.68	1789	7.67	5.21	0.68	1874	7.38	5.02	0.68	1960
23	20	8.70	4.87	0.56	1789	8.34	4.67	0.56	1896	8.09	4.53	0.56	1938	7.81	4.37	0.56	2024
23	22	9.05	3.98	0.44	1853	8.73	3.84	0.44	1970	8.52	3.75	0.44	2024	8.17	3.59	0.44	2109
24	18	8.34	6.01	0.72	1704	7.99	5.75	0.72	1789	7.67	5.52	0.72	1874	7.38	5.32	0.72	1960
24	20	8.70	5.22	0.60	1789	8.34	5.01	0.60	1896	8.09	4.86	0.60	1938	7.81	4.69	0.60	2024
24	22	9.05	4.35	0.48	1853	8.73	4.19	0.48	1970	8.52	4.09	0.48	2024	8.17	3.92	0.48	2109
24	24	9.51	3.43	0.36	1938	9.16	3.30	0.36	2045	8.95	3.22	0.36	2109	8.66	3.12	0.36	2215
25	18	8.34	6.34	0.76	1704	7.99	6.07	0.76	1789	7.67	5.83	0.76	1874	7.38	5.61	0.76	1960
25	20	8.70	5.57	0.64	1789	8.34	5.34	0.64	1896	8.09	5.18	0.64	1938	7.81	5.00	0.64	2024
25	22	9.05	4.71	0.52	1853	8.73	4.54	0.52	1970	8.52	4.43	0.52	2024	8.17	4.25	0.52	2109
25	24	9.51	3.81	0.40	1938	9.16	3.66	0.40	2045	8.95	3.58	0.40	2109	8.66	3.46	0.40	2215
26	18	8.34	6.67	0.80	1704	7.99	6.39	0.80	1789	7.67	6.13	0.80	1874	7.38	5.91	0.80	1960
26	20	8.70	5.91	0.68	1789	8.34	5.67	0.68	1896	8.09	5.50	0.68	1938	7.81	5.31	0.68	2024
26	22	9.05	5.07	0.56	1853	8.73	4.89	0.56	1970	8.52	4.77	0.56	2024	8.17	4.57	0.56	2109
26	24	9.51	4.19	0.44	1938	9.16	4.03	0.44	2045	8.95	3.94	0.44	2109	8.66	3.81	0.44	2215
26	26	9.80	3.14	0.32	2045	9.51	3.04	0.32	2151	9.37	3.00	0.32	2215	9.09	2.91	0.32	2279
27	18	8.34	7.01	0.84	1704	7.99	6.71	0.84	1789	7.67	6.44	0.84	1874	7.38	6.20	0.84	1960
27	20	8.70	6.26	0.72	1789	8.34	6.01	0.72	1896	8.09	5.83	0.72	1938	7.81	5.62	0.72	2024
27	22	9.05	5.43	0.60	1853	8.73	5.24	0.60	1970	8.52	5.11	0.60	2024	8.17	4.90	0.60	2109
27	24	9.51	4.57	0.48	1938	9.16	4.40	0.48	2045	8.95	4.29	0.48	2109	8.66	4.16	0.48	2215
27	26	9.80	3.53	0.36	2045	9.51	3.43	0.36	2151	9.37	3.37	0.36	2215	9.09	3.27	0.36	2279
28	18	8.34	7.34	0.88	1704	7.99	7.03	0.88	1789	7.67	6.75	0.88	1874	7.38	6.50	0.88	1960
28	20	8.70	6.61	0.76	1789	8.34	6.34	0.76	1896	8.09	6.15	0.76	1938	7.81	5.94	0.76	2024
28	22	9.05	5.79	0.64	1853	8.73	5.59	0.64	1970	8.52	5.45	0.64	2024	8.17	5.23	0.64	2109
28	24	9.51	4.95	0.52	1938	9.16	4.76	0.52	2045	8.95	4.65	0.52	2109	8.66	4.50	0.52	2215
28	26	9.80	3.92	0.40	2045	9.51	3.81	0.40	2151	9.37	3.75	0.40	2215	9.09	3.64	0.40	2279
29	18	8.34	7.68	0.92	1704	7.99	7.35	0.92	1789	7.67	7.05	0.92	1874	7.38	6.79	0.92	1960
29	20	8.70	6.96	0.80	1789	8.34	6.67	0.80	1896	8.09	6.48	0.80	1938	7.81	6.25	0.80	2024
29	22	9.05	6.16	0.68	1853	8.73	5.94	0.68	1970	8.52	5.79	0.68	2024	8.17	5.55	0.68	2109
29	24	9.51	5.33	0.56	1938	9.16	5.13	0.56	2045	8.95	5.01	0.56	2109	8.66	4.85	0.56	2215
29	26	9.80	4.31	0.44	2045	9.51	4.19	0.44	2151	9.37	4.12	0.44	2215	9.09	4.00	0.44	2279
30	18	8.34	8.01	0.96	1704	7.99	7.67	0.96	1789	7.67	7.36	0.96	1874	7.38	7.09	0.96	1960
30	20	8.70	7.31	0.84	1789	8.34	7.01	0.84	1896	8.09	6.80	0.84	1938	7.81	6.56	0.84	2024
30	22	9.05	6.52	0.72	1853	8.73	6.29	0.72	1970	8.52	6.13	0.72	2024	8.17	5.88	0.72	2109
30	24	9.51	5.71	0.60	1938	9.16	5.50	0.60	2045	8.95	5.37	0.60	2109	8.66	5.20	0.60	2215
30	26	9.80	4.70	0.48	2045	9.51	4.57	0.48	2151	9.37	4.50	0.48	2215	9.09	4.36	0.48	2279
31	18	8.34	8.34	1.00	1704	7.99	7.99	1.00	1789	7.67	7.67	1.00	1874	7.38	7.38	1.00	1960
31	20	8.70	7.65	0.88	1789	8.34	7.34	0.88	1896	8.09	7.12	0.88	1938	7.81	6.87	0.88	2024
31	22	9.05	6.88	0.76	1853	8.73	6.64	0.76	1970	8.52	6.48	0.76	2024	8.17	6.21	0.76	2109
31	24	9.51	6.09	0.64	1938	9.16	5.86	0.64	2045	8.95	5.73	0.64	2109	8.66	5.54	0.64	2215
31	26	9.80	5.09	0.52	2045	9.51	4.95	0.52	2151	9.37	4.87	0.52	2215	9.09	4.73	0.52	2279
32	18	8.34	8.34	1.00	1704	7.99	7.99	1.00	1789	7.67	7.67	1.00	1874	7.38	7.38	1.00	1960
32	20	8.70	8.00	0.92	1789	8.34	7.68	0.92	1896	8.09	7.45	0.92	1938	7.81	7.19	0.92	2024
32	22	9.05	7.24	0.80	1853	8.73	6.99	0.80	1970	8.52	6.82	0.80	2024	8.17	6.53	0.80	2109
32	24	9.51	6.47	0.68	1938	9.16	6.23	0.68	2045	8.95	6.08	0.68	2109	8.66	5.89	0.68	2215
32	26	9.80	5.49	0.56	2045	9.51	5.33	0.56	2151	9.37	5.25	0.56	2215	9.09	5.09	0.56	2279

**NOTE** Q : Total capacity (kW) SHF : Sensible heat factor DB : Dry-bulb temperature  
 SHC : Sensible heat capacity (kW) INPUT : Total power input (W) WB : Wet-bulb temperature

**PERFORMANCE DATA COOL operation at Rated frequency**

**MUZ-GF71VE**

CAPACITY: 7.1 kW

SHF: 0.78

INPUT: 2130 W

INDOOR DB (°C)	INDOOR WB (°C)	OUTDOOR DB (°C)											
		35				40				46			
		Q	SHC	SHF	INPUT	Q	SHC	SHF	INPUT	Q	SHC	SHF	INPUT
21	18	6.96	4.17	0.60	2087	6.39	3.83	0.60	2215	5.89	3.54	0.60	2300
21	20	7.31	3.51	0.48	2173	6.82	3.27	0.48	2279	6.32	3.03	0.48	2407
22	18	6.96	4.45	0.64	2087	6.39	4.09	0.64	2215	5.89	3.77	0.64	2300
22	20	7.31	3.80	0.52	2173	6.82	3.54	0.52	2279	6.32	3.29	0.52	2407
22	22	7.74	3.10	0.40	2258	7.24	2.90	0.40	2386	6.75	2.70	0.40	2471
23	18	6.96	4.73	0.68	2087	6.39	4.35	0.68	2215	5.89	4.01	0.68	2300
23	20	7.31	4.10	0.56	2173	6.82	3.82	0.56	2279	6.32	3.54	0.56	2407
23	22	7.74	3.41	0.44	2258	7.24	3.19	0.44	2386	6.75	2.97	0.44	2471
24	18	6.96	5.01	0.72	2087	6.39	4.60	0.72	2215	5.89	4.24	0.72	2300
24	20	7.31	4.39	0.60	2173	6.82	4.09	0.60	2279	6.32	3.79	0.60	2407
24	22	7.74	3.71	0.48	2258	7.24	3.48	0.48	2386	6.75	3.24	0.48	2471
24	24	8.17	2.94	0.36	2343	7.67	2.76	0.36	2450	7.24	2.61	0.36	2556
25	18	6.96	5.29	0.76	2087	6.39	4.86	0.76	2215	5.89	4.48	0.76	2300
25	20	7.31	4.68	0.64	2173	6.82	4.36	0.64	2279	6.32	4.04	0.64	2407
25	22	7.74	4.02	0.52	2258	7.24	3.77	0.52	2386	6.75	3.51	0.52	2471
25	24	8.17	3.27	0.40	2343	7.67	3.07	0.40	2450	7.24	2.90	0.40	2556
26	18	6.96	5.57	0.80	2087	6.39	5.11	0.80	2215	5.89	4.71	0.80	2300
26	20	7.31	4.97	0.68	2173	6.82	4.63	0.68	2279	6.32	4.30	0.68	2407
26	22	7.74	4.33	0.56	2258	7.24	4.06	0.56	2386	6.75	3.78	0.56	2471
26	24	8.17	3.59	0.44	2343	7.67	3.37	0.44	2450	7.24	3.19	0.44	2556
26	26	8.59	2.75	0.32	2428	8.09	2.59	0.32	2535	7.60	2.43	0.32	2641
27	18	6.96	5.84	0.84	2087	6.39	5.37	0.84	2215	5.89	4.95	0.84	2300
27	20	7.31	5.27	0.72	2173	6.82	4.91	0.72	2279	6.32	4.55	0.72	2407
27	22	7.74	4.64	0.60	2258	7.24	4.35	0.60	2386	6.75	4.05	0.60	2471
27	24	8.17	3.92	0.48	2343	7.67	3.68	0.48	2450	7.24	3.48	0.48	2556
27	26	8.59	3.09	0.36	2428	8.09	2.91	0.36	2535	7.60	2.73	0.36	2641
28	18	6.96	6.12	0.88	2087	6.39	5.62	0.88	2215	5.89	5.19	0.88	2300
28	20	7.31	5.56	0.76	2173	6.82	5.18	0.76	2279	6.32	4.80	0.76	2407
28	22	7.74	4.95	0.64	2258	7.24	4.63	0.64	2386	6.75	4.32	0.64	2471
28	24	8.17	4.25	0.52	2343	7.67	3.99	0.52	2450	7.24	3.77	0.52	2556
28	26	8.59	3.44	0.40	2428	8.09	3.24	0.40	2535	7.60	3.04	0.40	2641
29	18	6.96	6.40	0.92	2087	6.39	5.88	0.92	2215	5.89	5.42	0.92	2300
29	20	7.31	5.85	0.80	2173	6.82	5.45	0.80	2279	6.32	5.06	0.80	2407
29	22	7.74	5.26	0.68	2258	7.24	4.92	0.68	2386	6.75	4.59	0.68	2471
29	24	8.17	4.57	0.56	2343	7.67	4.29	0.56	2450	7.24	4.06	0.56	2556
29	26	8.59	3.78	0.44	2428	8.09	3.56	0.44	2535	7.60	3.34	0.44	2641
30	18	6.96	6.68	0.96	2087	6.39	6.13	0.96	2215	5.89	5.66	0.96	2300
30	20	7.31	6.14	0.84	2173	6.82	5.73	0.84	2279	6.32	5.31	0.84	2407
30	22	7.74	5.57	0.72	2258	7.24	5.21	0.72	2386	6.75	4.86	0.72	2471
30	24	8.17	4.90	0.60	2343	7.67	4.60	0.60	2450	7.24	4.35	0.60	2556
30	26	8.59	4.12	0.48	2428	8.09	3.89	0.48	2535	7.60	3.65	0.48	2641
31	18	6.96	6.96	1.00	2087	6.39	6.39	1.00	2215	5.89	5.89	1.00	2300
31	20	7.31	6.44	0.88	2173	6.82	6.00	0.88	2279	6.32	5.56	0.88	2407
31	22	7.74	5.88	0.76	2258	7.24	5.50	0.76	2386	6.75	5.13	0.76	2471
31	24	8.17	5.23	0.64	2343	7.67	4.91	0.64	2450	7.24	4.63	0.64	2556
31	26	8.59	4.47	0.52	2428	8.09	4.21	0.52	2535	7.60	3.95	0.52	2641
32	18	6.96	6.96	1.00	2087	6.39	6.39	1.00	2215	5.89	5.89	1.00	2300
32	20	7.31	6.73	0.92	2173	6.82	6.27	0.92	2279	6.32	5.81	0.92	2407
32	22	7.74	6.19	0.80	2258	7.24	5.79	0.80	2386	6.75	5.40	0.80	2471
32	24	8.17	5.55	0.68	2343	7.67	5.21	0.68	2450	7.24	4.92	0.68	2556
32	26	8.59	4.81	0.56	2428	8.09	4.53	0.56	2535	7.60	4.25	0.56	2641

**NOTE** Q : Total capacity (kW) SHF : Sensible heat factor DB : Dry-bulb temperature  
 SHC : Sensible heat capacity (kW) INPUT : Total power input (W) WB : Wet-bulb temperature

**PERFORMANCE DATA HEAT operation at Rated frequency**  
**MUZ-GF60VE**

CAPACITY: 6.8 kW INPUT: 1810 W

INDOOR DB (°C)	OUTDOOR WB (°C)													
	-10		-5		0		5		10		15		20	
	Q	INPUT	Q	INPUT	Q	INPUT	Q	INPUT	Q	INPUT	Q	INPUT	Q	INPUT
15	4.28	1177	5.17	1412	6.05	1593	6.94	1720	7.82	1828	8.64	1882	9.52	1919
21	4.08	1267	4.90	1502	5.78	1665	6.60	1792	7.48	1882	8.30	1937	9.15	2009
26	3.67	1358	4.56	1593	5.37	1756	6.26	1882	7.14	1973	7.96	2027	8.84	2082

**MUZ-GF71VE**

CAPACITY: 8.1 kW INPUT: 2230 W

INDOOR DB (°C)	OUTDOOR WB (°C)													
	-10		-5		0		5		10		15		20	
	Q	INPUT	Q	INPUT	Q	INPUT	Q	INPUT	Q	INPUT	Q	INPUT	Q	INPUT
15	5.10	1450	6.16	1739	7.21	1962	8.26	2119	9.32	2252	10.29	2319	11.34	2364
21	4.86	1561	5.83	1851	6.89	2052	7.86	2208	8.91	2319	9.88	2386	10.89	2475
26	4.37	1673	5.43	1962	6.40	2163	7.45	2319	8.51	2431	9.48	2498	10.53	2565

**NOTE:** Q: Total capacity (kW) INPUT : Total power input (W) DB: Dry-bulb temperature WB: Wet-bulb temperature

**MUZ-GF60VE MUZ-GF71VE**

**9-1. OUTDOOR FAN MOTOR CONTROL**

The fan motor turns ON/OFF, interlocking with the compressor.

[ON] The fan motor turns ON 5 seconds before the compressor starts up.

[OFF] The fan motor turns OFF 15 seconds after the compressor has stopped running.

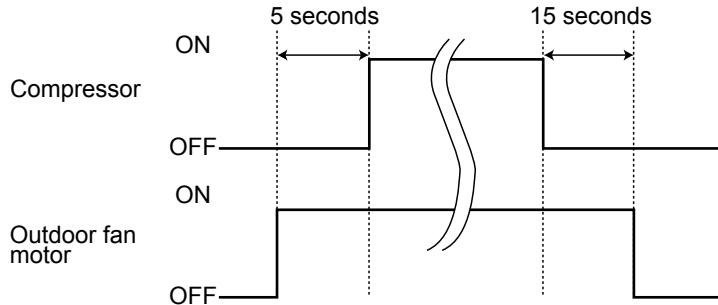

**9-2. R.V. COIL CONTROL**

Heating . . . . . ON

Cooling . . . . . OFF

Dry . . . . . OFF

**NOTE:** The 4-way valve reverses for 5 seconds right before start-up of the compressor.

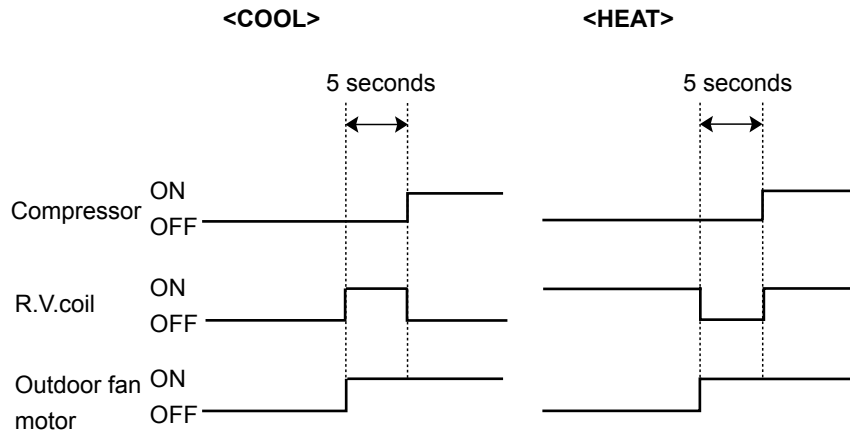

**9-3. RELATION BETWEEN MAIN SENSOR AND ACTUATOR**

Sensor	Purpose	Actuator					
		Compressor	LEV	Outdoor fan motor	R.V.coil	Indoor fan motor	Defrost heater
Discharge temperature thermistor	Protection	○	○				
Indoor coil temperature thermistor	Cooling: Coil frost prevention	○					
	Heating: High pressure protection	○	○				
Defrost thermistor	Heating: Defrosting	○	○	○	○	○	
Fin temperature thermistor	Protection	○		○			
Ambient temperature thermistor	Cooling: Low ambient temperature operation	○	○	○			
	Heating: Defrosting (Heater)						○
Outdoor heat exchanger temperature thermistor	Cooling: Low ambient temperature operation	○	○	○			
	Cooling: High pressure protection	○	○	○			

**MUZ-GF60VE MUZ-GF71VE**

**10-1. CHANGE IN DEFROST SETTING**

**Changing defrost finish temperature**

<JS> To change the defrost finish temperature, cut/solder the JS wire of the outdoor inverter P.C. board. (Refer to 11-6-1.)

Jumper wire		Defrost finish temperature (°C)	
		MUZ-GF	
		60VE	71VE
JS	Soldered (Initial setting)	10	10
	None (Cut)	18	18

**10-2. PRE-HEAT CONTROL SETTING**

**PRE-HEAT CONTROL**

Prolonged low load operation, in which the thermostat is OFF for a long time, at low outside temperature (0°C or less) may cause the following troubles. To prevent those troubles, activate the pre-heat control.

- 1) If moisture gets into the refrigerant cycle and freezes, it may interfere the start-up of the compressor.
- 2) If liquid refrigerant collects in the compressor, a failure in the compressor may occur.

The pre-heat control turns ON when the compressor temperature is 20°C or below. When the pre-heat control turns ON, the compressor is energized. (About 70 W)

**Pre-heat control setting**

<JK>

ON: To activate the pre-heat control, cut JK wire of the inverter P.C. board.

OFF: To deactivate the pre-heat control, solder JK wire of the inverter P.C. board.

(Refer to 11-6.1)

**NOTE:** When the inverter P.C. board is replaced, check JK wire, and cut/solder it if necessary.

**MUZ-GF60VE MUZ-GF71VE**

**11-1. CAUTIONS ON TROUBLESHOOTING**

**1. Before troubleshooting, check the following**

- 1) Check the power supply voltage.
- 2) Check the indoor/outdoor connecting wire for miswiring.

**2. Take care of the following during servicing**

- 1) Before servicing the air conditioner, be sure to turn OFF the main unit first with the remote controller, and after confirming the horizontal vane is closed, turn OFF the breaker and/or disconnect the power plug.
- 2) Be sure to turn OFF the power supply before removing the front panel, the cabinet, the top panel, and the electronic control P.C. board.
- 3) When removing the electrical parts, be careful of the residual voltage of smoothing capacitor.
- 4) When removing the electronic control P.C. board, hold the edge of the board with care NOT to apply stress on the components.
- 5) When connecting or disconnecting the connectors, hold the housing of the connector. DO NOT pull the lead wires.

<Incorrect>

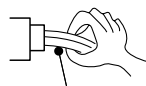

**Lead wiring**

<Correct>

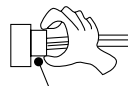

**Housing point**

**3. Troubleshooting procedure**

- 1) Check if the OPERATION INDICATOR lamp on the indoor unit is flashing on and off to indicate an abnormality. To make sure, check how many times the OPERATION INDICATOR lamp is flashing on and off before starting service work.
- 2) Before servicing, check that the connector and terminal are connected properly.
- 3) When the electronic control P.C. board seems to be defective, check the copper foil pattern for disconnection and the components for bursting and discoloration.
- 4) Refer to 11-2 and 11-3.

## 11-2. FAILURE MODE RECALL FUNCTION

Outline of the function

This air conditioner can memorize the abnormal condition which has occurred once.

Even though LED indication listed on the troubleshooting check table (11-3.) disappears, the memorized failure details can be recalled.

### 1. Flow chart of failure mode recall function for the indoor/outdoor unit

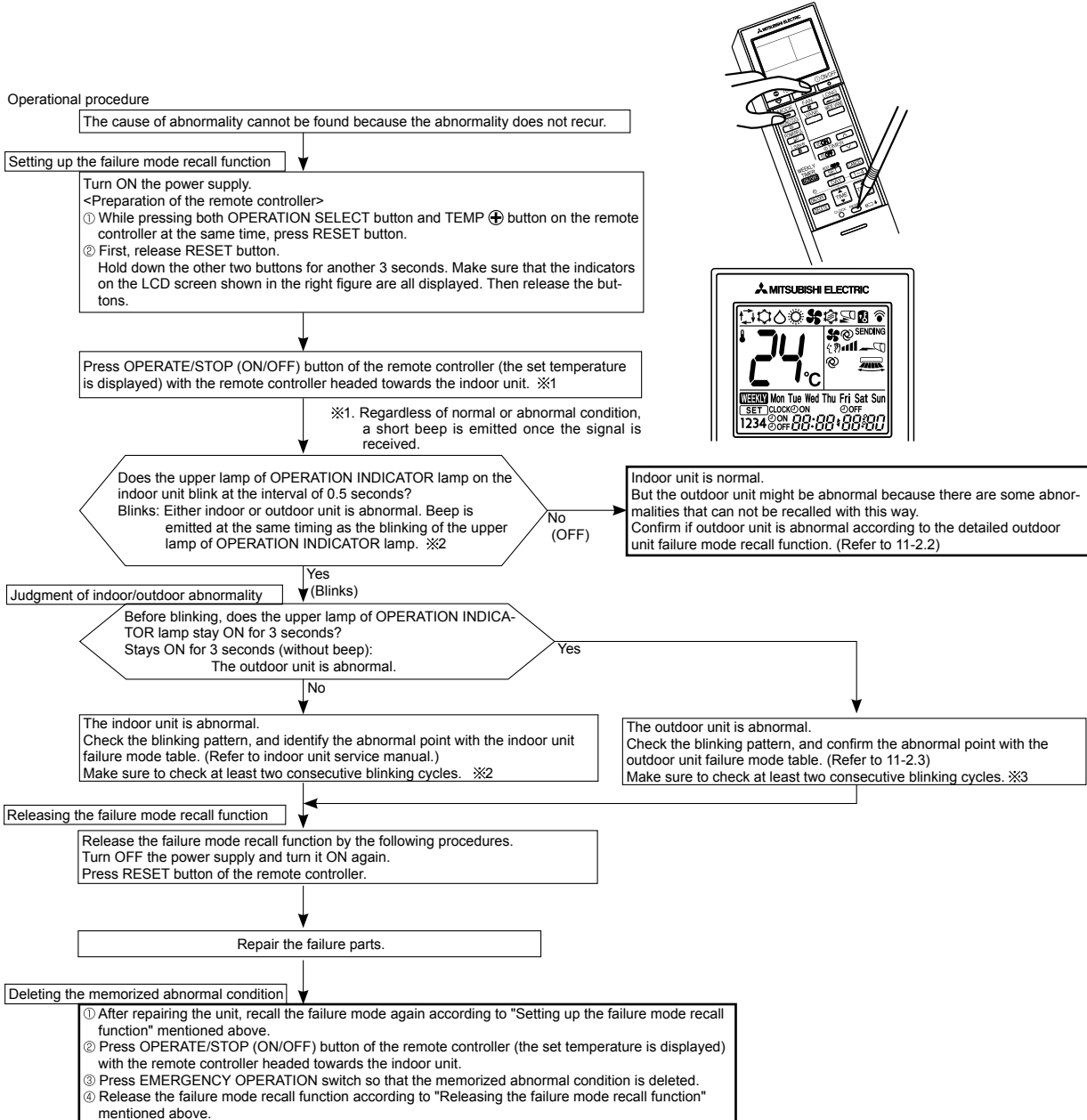

**NOTE:** 1. Make sure to release the failure mode recall function after it is set up, otherwise the unit cannot operate properly.  
2. If the abnormal condition is not deleted from the memory, the last abnormal condition is kept memorized.

※2. Blinking pattern when the indoor unit is abnormal:

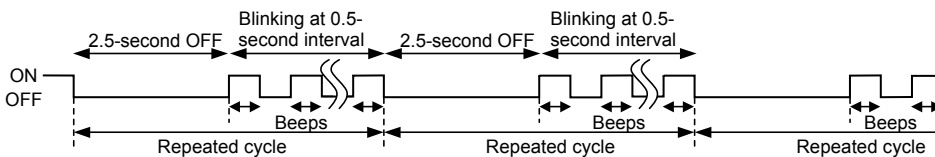

※3. Blinking pattern when the outdoor unit is abnormal:

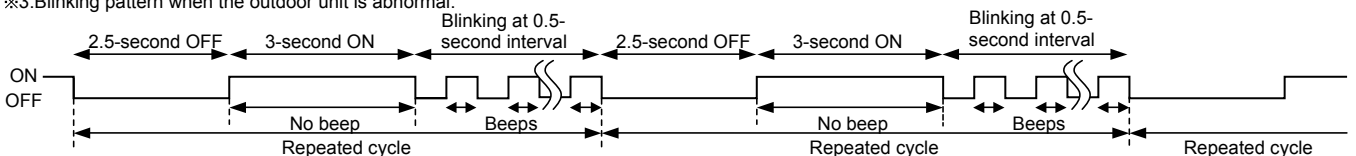

## 2. Flow chart of the detailed outdoor unit failure mode recall function

### Operational procedure

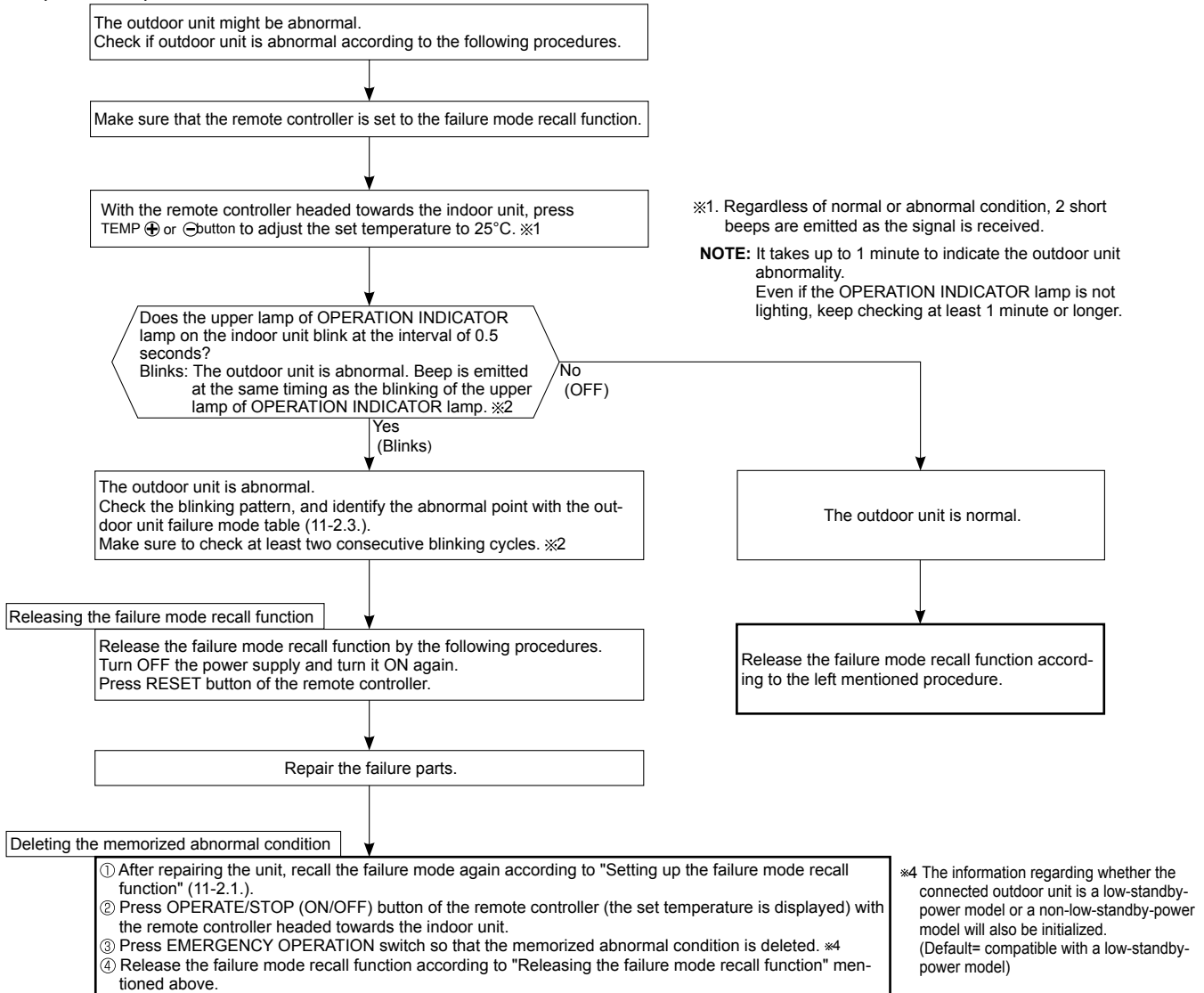

**NOTE:** 1. Make sure to release the failure mode recall function after it is set up, otherwise the unit cannot operate properly.  
2. If the abnormal condition is not deleted from the memory, the last abnormal condition is kept memorized.

※2. Blinking pattern when outdoor unit is abnormal:

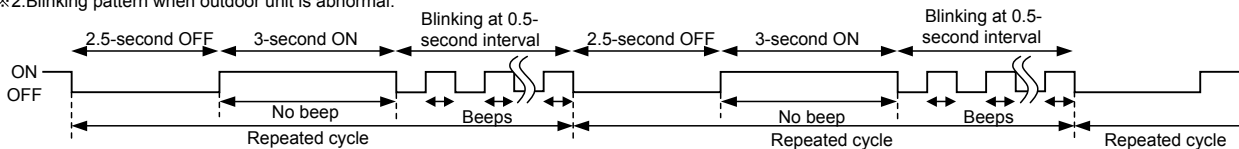



### 3. Outdoor unit failure mode table

The upper lamp of OPERATION INDICATOR lamp (Indoor unit)	Abnormal point (Failure mode / protection)	LED indication (Outdoor P.C. board)	Condition	Remedy	Indoor/outdoor unit failure mode recall function	Outdoor unit failure mode recall function
OFF	None (Normal)	—	—	—	—	—
1-time flash 2.5 seconds OFF	Indoor/outdoor communication, receiving error	—	Any signals from the inverter P.C. board cannot be received normally for 3 minutes.	•Refer to 11-5. ㉓ How to check miswiring and serial signal error.	○	○
	Indoor/outdoor communication, receiving error	—	Although the inverter P.C. board sends signal "0", signal "1" has been received 30 consecutive times.	•Refer to 11-5. ㉓ How to check miswiring and serial signal error.		
2-time flash 2.5 seconds OFF	Outdoor power system	—	Overcurrent protection cut-out operates 3 consecutive times within 1 minute after the compressor gets started.	•Reconnect connectors. •Refer to 11-5. ㉓ "How to check inverter/compressor". •Check stop valve.	○	○
3-time flash 2.5 seconds OFF	Discharge temperature thermistor	1-time flash every 2.5 seconds	Thermistor shorts or opens during compressor running.	•Refer to 11-5. ㉓ "Check of outdoor thermistors". Defective outdoor thermistors can be identified by checking the blinking pattern of LED.	○	○
	Defrost thermistor	—				
	Fin temperature thermistor	3-time flash 2.5 seconds OFF				
	P.C. board temperature thermistor	4-time flash 2.5 seconds OFF				
	Ambient temperature thermistor	2-time flash 2.5 seconds OFF				
Outdoor heat exchanger temperature thermistor	—	—				
4-time flash 2.5 seconds OFF	Overcurrent	11-time flash 2.5 seconds OFF	Large current flows into IGBT module (IC700).	•Reconnect compressor connector. •Refer to 11-5. ㉓ "How to check inverter/compressor". •Check stop valve.	—	○
	Compressor synchronous abnormality (Compressor start-up failure protection)	12-time flash 2.5 seconds OFF	Compressor current is abnormal.	•Reconnect compressor connector. •Refer to 11-5. ㉓ "How to check inverter/compressor".	—	○
5-time flash 2.5 seconds OFF	Discharge temperature	—	Temperature of discharge temperature thermistor exceeds 116°C, compressor stops. Compressor can restart if discharge temperature thermistor reads 100°C or less 3 minutes later.	•Check refrigerant circuit and refrigerant amount. •Refer to 11-5. ㉓ "Check of LEV".	—	○
6-time flash 2.5 seconds OFF	High pressure	—	Temperature indoor coil thermistor exceeds 70°C in HEAT mode. Temperature defrost thermistor exceeds 70°C in COOL mode.	•Check refrigerant circuit and refrigerant amount. •Check stop valve.	—	○
7-time flash 2.5 seconds OFF	Fin temperature/ P.C. board temperature	7-time flash 2.5 seconds OFF	Temperature of fin temperature thermistor on the inverter P.C. board exceeds 75 ~ 80°C, or temperature of P.C. board temperature thermistor on the inverter P.C. board exceeds 70 ~ 75°C.	•Check around outdoor unit. •Check outdoor unit air passage. •Refer to 11-5. ㉓ "Check of outdoor fan motor".	—	○
8-time flash 2.5 seconds OFF	Outdoor fan motor	—	Outdoor fan has stopped 3 times in a row within 30 seconds after outdoor fan start-up.	•Refer to 11-5. ㉓ "Check of outdoor fan motor". Refer to 11-5. ㉓ "Check of inverter P.C. board".	—	○
9-time flash 2.5 seconds OFF	Memory data	5-time flash 2.5 seconds OFF	Memory data cannot be read.	•Replace the inverter P.C. board.	○	○
	IGBT module (IC700)	6-time flash 2.5 seconds OFF	•Output of IGBT module (IC700) is short. •Wiring of compressor is short.	•Refer to 11-5. ㉓ "How to check inverter/compressor".		
10-time flash 2.5 seconds OFF	Discharge temperature	—	Temperature of discharge temperature thermistor has been 50°C or less for 20 minutes.	•Refer to 11-5. ㉓ "Check of LEV". •Check refrigerant circuit and refrigerant amount.	—	○
11-time flash 2.5 seconds OFF	Bus-bar voltage (DC)	8-time flash 2.5 seconds OFF	Bus-bar voltage cannot be detected normally.	•Refer to 11-5. ㉓ "How to check inverter/compressor".	—	○
	Compressor current	9-time flash 2.5 seconds OFF	Compressor current cannot be detected normally.			
14-time flash 2.5 seconds OFF	Stop valve (Closed valve)	14-time flash 2.5 seconds OFF	Closed valve is detected by compressor current.	•Check stop valve	○	○
	4-way valve/ Pipe temperature	16-time flash 2.5 seconds OFF	The 4-way valve does not work properly. The indoor coil thermistor detects an abnormal temperature.	•Check 4-way valve. •Replace inverter P.C. board.		

**NOTE:** Blinking patterns of this mode differ from the ones of Troubleshooting check table (11-3.).

### 11-3. TROUBLESHOOTING CHECK TABLE

No.	Symptom	LED indication	Abnormal point/ Condition	Condition	Remedy	
1	Outdoor unit does not operate.	1-time flash every 2.5 seconds	Outdoor power system	Overcurrent protection cut-out operates 3 consecutive times within 1 minute after the compressor gets started.	<ul style="list-style-type: none"> <li>Reconnect connector of compressor.</li> <li>Refer to 11-5.Ⓐ "How to check inverter/compressor".</li> <li>Check stop valve.</li> </ul>	
2			Outdoor thermistors	Discharge temperature thermistor, fin temperature thermistor, defrost thermistor, P.C. board temperature thermistor, outdoor heat exchanger temperature thermistor or ambient temperature thermistor shorts or opens during compressor running.	Refer to 11-5.Ⓢ "Check of outdoor thermistors".	
3			Outdoor control system	Memory data cannot be read.  (The upper lamp of OPERATION INDICATOR lamp of the indoor unit lights up or flashes 7-time.)	Replace inverter P.C. board.	
4		6-time flash 2.5 seconds OFF	Serial communication	The communication fails between the indoor and outdoor unit for 3 minutes.	<ul style="list-style-type: none"> <li>Check connection between the inverter P.C. board and relay P.C. board.</li> <li>Refer to 11-5.Ⓜ "How to check miswiring and serial signal error."</li> </ul>	
5		11-time flash 2.5 seconds OFF	Stop valve/ Closed valve	Closed valve is detected.	Check stop valve.	
6		16-time flash 2.5 seconds OFF	4-way valve/ Pipe temperature	The 4-way valve does not work properly. The indoor coil thermistor detects an abnormal temperature.	<ul style="list-style-type: none"> <li>Refer to 11-5.Ⓣ "Check of R.V. coil".</li> <li>Replace inverter P.C. board.</li> </ul>	
7	'Outdoor unit stops and restarts 3 minutes later' is repeated.	2-time flash 2.5 seconds OFF	Overcurrent protection	Large current flows into IGBT module (IC700).	<ul style="list-style-type: none"> <li>Reconnect connector of compressor.</li> <li>Refer to 11-5.Ⓐ "How to check inverter/compressor".</li> <li>Check stop valve.</li> </ul>	
8		3-time flash 2.5 seconds OFF	Discharge temperature overheat protection	Temperature of discharge temperature thermistor exceeds 116°C, compressor stops. Compressor can restart if discharge temperature thermistor reads 100°C or less 3 minutes later.	<ul style="list-style-type: none"> <li>Check refrigerant circuit and refrigerant amount.</li> <li>Refer to 11-5.Ⓚ "Check of LEV".</li> </ul>	
9		4-time flash 2.5 seconds OFF	Fin temperature /P.C. board temperature thermistor overheat protection	Temperature of fin temperature thermistor on the heat sink exceeds 75 ~ 80°C or temperature of P.C. board temperature thermistor on the inverter P.C. board exceeds 70 ~ 75°C.	<ul style="list-style-type: none"> <li>Check around outdoor unit.</li> <li>Check outdoor unit air passage.</li> <li>Refer to 11-5.Ⓛ "Check of outdoor fan motor".</li> </ul>	
10		5-time flash 2.5 seconds OFF	High pressure protection	Indoor coil thermistor exceeds 70°C in HEAT mode. Defrost thermistor exceeds 70°C in COOL mode.	<ul style="list-style-type: none"> <li>Check refrigerant circuit and refrigerant amount.</li> <li>Check stop valve.</li> </ul>	
11		8-time flash 2.5 seconds OFF	Compressor synchronous abnormality	Compressor current is abnormal.	<ul style="list-style-type: none"> <li>Reconnect connector of compressor.</li> <li>Refer to 11-5.Ⓐ "How to check inverter/compressor".</li> </ul>	
12		10-time flash 2.5 seconds OFF	Outdoor fan motor	Outdoor fan has stopped 3 times in a row within 30 seconds after outdoor fan start-up.	<ul style="list-style-type: none"> <li>Refer to 11-5.Ⓛ "Check of outdoor fan motor."</li> <li>Refer to 11-5.Ⓛ "Check of inverter P.C. board."</li> </ul>	
13		12-time flash 2.5 seconds OFF	Compressor current	Compressor current cannot be detected normally.	Refer to 11-5.Ⓐ "How to check inverter/compressor".	
14		13-time flash 2.5 seconds OFF	Bus-bar voltage (DC)	Bus-bar voltage cannot be detected normally.	<ul style="list-style-type: none"> <li>It occurs with following case. Instantaneous power voltage drop. (Short time power failure)</li> <li>Refer to 11-5.Ⓞ "Check of power supply".</li> <li>Refer to 11-5.Ⓐ "How to check inverter/compressor".</li> </ul>	
15		Outdoor unit operates.	1-time flash 2.5 seconds OFF	Frequency drop by current protection	Current from power outlet is nearing breaker capacity.	The unit is normal, but check the following.
16		3-time flash 2.5 seconds OFF	Frequency drop by high pressure protection	Temperature of indoor coil thermistor exceeds 55°C in HEAT mode, compressor frequency lowers.	<ul style="list-style-type: none"> <li>Check if indoor filters are clogged.</li> <li>Check if refrigerant is short.</li> <li>Check if indoor/outdoor unit air circulation is short cycled.</li> </ul>	
				Frequency drop by defrosting in COOL mode		Indoor coil thermistor reads 8°C or less in COOL mode, compressor frequency lowers.
17		4-time flash 2.5 seconds OFF	Frequency drop by discharge temperature protection	Temperature of discharge temperature thermistor exceeds 111°C, compressor frequency lowers.	<ul style="list-style-type: none"> <li>Check refrigerant circuit and refrigerant amount.</li> <li>Refer to 11-5.Ⓚ "Check of LEV".</li> <li>Refer to 11-5.Ⓢ "Check of outdoor thermistors".</li> </ul>	
18		7-time flash 2.5 seconds OFF	Low discharge temperature protection	Temperature of discharge temperature thermistor has been 50°C or less for 20 minutes.	<ul style="list-style-type: none"> <li>Refer to 11-5.Ⓚ "Check of LEV".</li> <li>Check refrigerant circuit and refrigerant amount.</li> </ul>	

No.	Symptom	LED indication	Abnormal point/ Condition	Condition	Remedy
19	Outdoor unit operates.	8-time flash 2.5 seconds OFF	Zero cross detecting circuit	Zero cross signal cannot be detected.	<ul style="list-style-type: none"> <li>It occurs with following cases. <ul style="list-style-type: none"> <li>1 Instantaneous power voltage drop. (Short time power failure)</li> <li>2 Distortion of primary voltage</li> </ul> </li> <li>Refer to 11-5. ㉞ "Check of power supply".</li> </ul>
20		9-time flash 2.5 seconds OFF	Inverter check mode	The connector of compressor is disconnected, inverter check mode starts.	<ul style="list-style-type: none"> <li>Check if the connector of the compressor is correctly connected. Refer to 11-5. ㉞ "How to check inverter/compressor".</li> </ul>

**NOTE:** 1. The location of LED is illustrated at the right figure. Refer to 11-6.1.  
2. LED is lighted during normal operation.

The flashing frequency shows the number of times the LED blinks after every 2.5-second OFF.  
(Example) When the flashing frequency is "2".

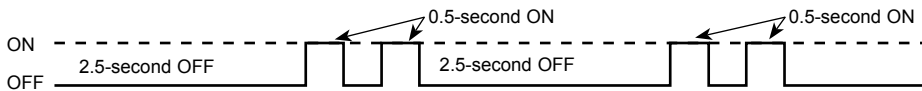

Inverter P.C. board

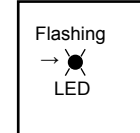

#### 11-4. TROUBLE CRITERION OF MAIN PARTS MUZ-GF60VE MUZ-GF71VE

Part name	Check method and criterion	Figure											
Defrost thermistor (RT61)		/											
Fin temperature thermistor (RT64)	Measure the resistance with a tester.												
Ambient temperature thermistor (RT65)	Refer to 11-6. "Test point diagram and voltage", 1. "Inverter P.C. board", for the chart of thermistor.												
Outdoor heat exchanger temperature thermistor (RT68)													
Discharge temperature thermistor (RT62)	Measure the resistance with a tester. Before measurement, hold the thermistor with your hands to warm it up. Refer to 11-6. "Test point diagram and voltage", 1. "Inverter P.C. board", for the chart of thermistor.	/											
Compressor	Measure the resistance between terminals using a tester. (Temperature: -10 ~ 40°C) <table border="1" style="margin-left: auto; margin-right: auto;"> <thead> <tr> <th></th> <th colspan="2">Normal (Ω)</th> </tr> <tr> <th></th> <th>MUZ-GF60VE</th> <th>MUZ-GF71VE</th> </tr> </thead> <tbody> <tr> <td>U-V</td> <td rowspan="3" style="text-align: center; vertical-align: middle;">0.78 ~ 1.11</td> <td rowspan="3" style="text-align: center; vertical-align: middle;">0.83 ~ 1.18</td> </tr> <tr> <td>U-W</td> </tr> <tr> <td>V-W</td> </tr> </tbody> </table>		Normal (Ω)			MUZ-GF60VE	MUZ-GF71VE	U-V	0.78 ~ 1.11	0.83 ~ 1.18	U-W	V-W	
	Normal (Ω)												
	MUZ-GF60VE	MUZ-GF71VE											
U-V	0.78 ~ 1.11	0.83 ~ 1.18											
U-W													
V-W													
Outdoor fan motor	Measure the resistance between lead wires using a tester. (Temperature: -10 ~ 40°C) <table border="1" style="margin-left: auto; margin-right: auto;"> <thead> <tr> <th>Color of lead wire</th> <th>Normal (Ω)</th> </tr> </thead> <tbody> <tr> <td>RED - BLK</td> <td rowspan="3" style="text-align: center; vertical-align: middle;">12 ~ 17</td> </tr> <tr> <td>BLK - WHT</td> </tr> <tr> <td>WHT - RED</td> </tr> </tbody> </table>	Color of lead wire	Normal (Ω)	RED - BLK	12 ~ 17	BLK - WHT	WHT - RED						
Color of lead wire	Normal (Ω)												
RED - BLK	12 ~ 17												
BLK - WHT													
WHT - RED													
R. V. coil (21S4)	Measure the resistance using a tester. (Temperature: -10 ~ 40°C) <table border="1" style="margin-left: auto; margin-right: auto;"> <thead> <tr> <th>Normal (kΩ)</th> </tr> </thead> <tbody> <tr> <td style="text-align: center;">1.85 ~ 2.24</td> </tr> </tbody> </table>	Normal (kΩ)	1.85 ~ 2.24	/									
Normal (kΩ)													
1.85 ~ 2.24													
Expansion valve coil (LEV)	Measure the resistance using a tester. (Temperature: -10 ~ 40°C) <table border="1" style="margin-left: auto; margin-right: auto;"> <thead> <tr> <th>Color of lead wire</th> <th>Normal (Ω)</th> </tr> </thead> <tbody> <tr> <td>RED - ORN</td> <td rowspan="5" style="text-align: center; vertical-align: middle;">37 ~ 54</td> </tr> <tr> <td>RED - WHT</td> </tr> <tr> <td>RED - BLU</td> </tr> <tr> <td>RED - YLW</td> </tr> <tr> <td>RED - YLW</td> </tr> </tbody> </table>	Color of lead wire	Normal (Ω)	RED - ORN	37 ~ 54	RED - WHT	RED - BLU	RED - YLW	RED - YLW				
Color of lead wire	Normal (Ω)												
RED - ORN	37 ~ 54												
RED - WHT													
RED - BLU													
RED - YLW													
RED - YLW													

## 11-5. TROUBLESHOOTING FLOW

### A How to check inverter/compressor

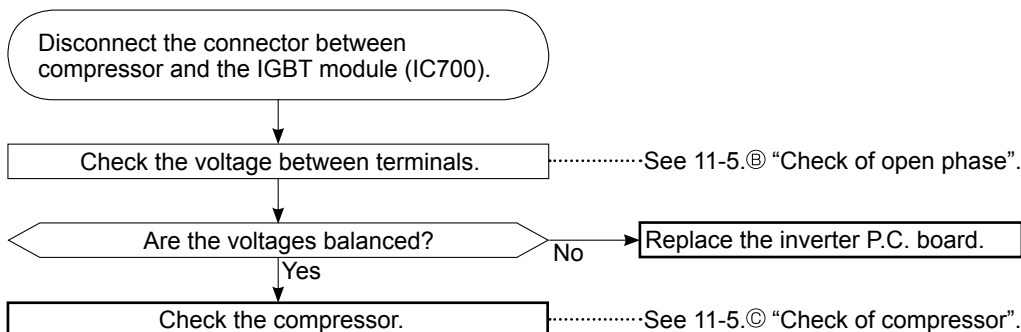

### B Check of open phase

- With the connector between the compressor and the IGBT module (IC700) disconnected, activate the inverter and check if the inverter is normal by measuring the **balance of voltage** between the terminals.

Output voltage is 50 - 130 V. (The voltage may differ according to the tester.)

<< Operation method >>

Start cooling or heating operation by pressing EMERGENCY OPERATION switch on the indoor unit. (TEST RUN OPERATION: Refer to 8-3.)

<< Measurement point >>

At 3 points

BLK (U)-WHT (V)

※ Measure AC voltage between the lead wires at 3 points.

BLK (U)-RED (W)

WHT(V)-RED (W)

- NOTE:**
- Output voltage varies according to power supply voltage.
  - Measure the voltage by analog type tester.
  - During this check, LED of the inverter P.C. board flashes 9 times. (Refer to 11-6.1.)

### C Check of compressor

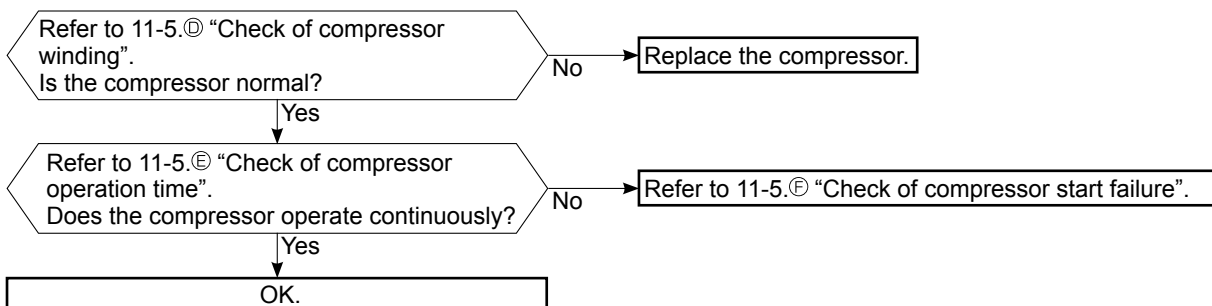

## D Check of compressor winding

- Disconnect the connector between the compressor and the IGBT module (IC700), and measure the resistance between the compressor terminals.

<<Measurement point>>

At 3 points

BLK-WHT

BLK-RED

※ Measure the resistance between the lead wires at 3 points.

WHT-RED

<<Judgement>>

Refer to 11-4.

0 [Ω] .....Abnormal [short]

Infinite [Ω] .....Abnormal [open]

**NOTE:** Be sure to zero the ohmmeter before measurement.

## E Check of compressor operation time

- Connect the compressor and activate the inverter. Then measure the time until the inverter stops due to over current.

<<Operation method>>

Start heating or cooling operation by pressing EMERGENCY OPERATION switch on the indoor unit. (TEST RUN OPERATION: Refer to 8-3.)

<<Measurement>>

Measure the time from the start of compressor to the stop of compressor due to overcurrent.

<<Judgement>>

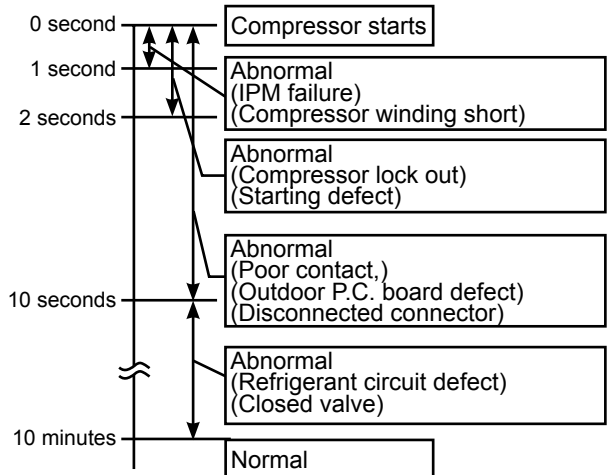

## F Check of compressor start failure

Make sure that ①~④ is normal.

•Electrical circuit check

①. Contact of the compressor connector

②. Output voltage of inverter P.C. board and balance of them (See 11-5.⑥)

③. Direct current voltage between JP715(+) and JP30(-) on the inverter P.C. board

④. Voltage between outdoor terminal block S1-S2

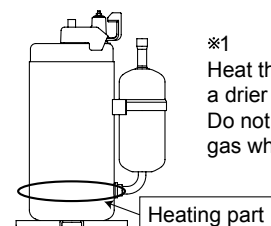
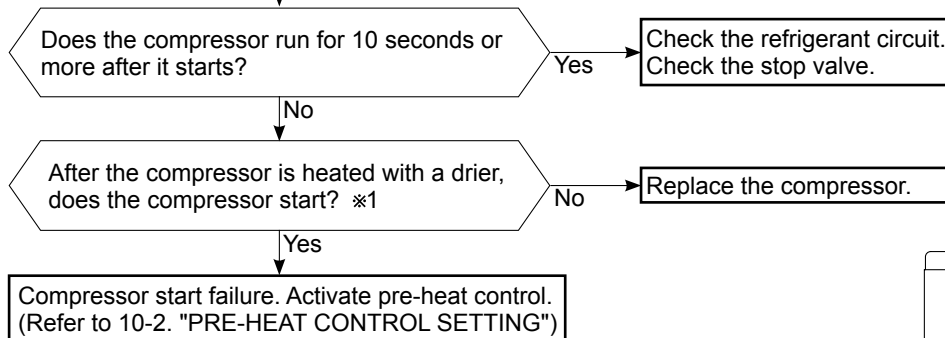

※1  
Heat the compressor with a drier for about 20 minutes. Do not recover refrigerant gas while heating.

### G Check of outdoor thermistors

Disconnect the connector of thermistor in the outdoor P.C. board (see below table), and measure the resistance of thermistor.

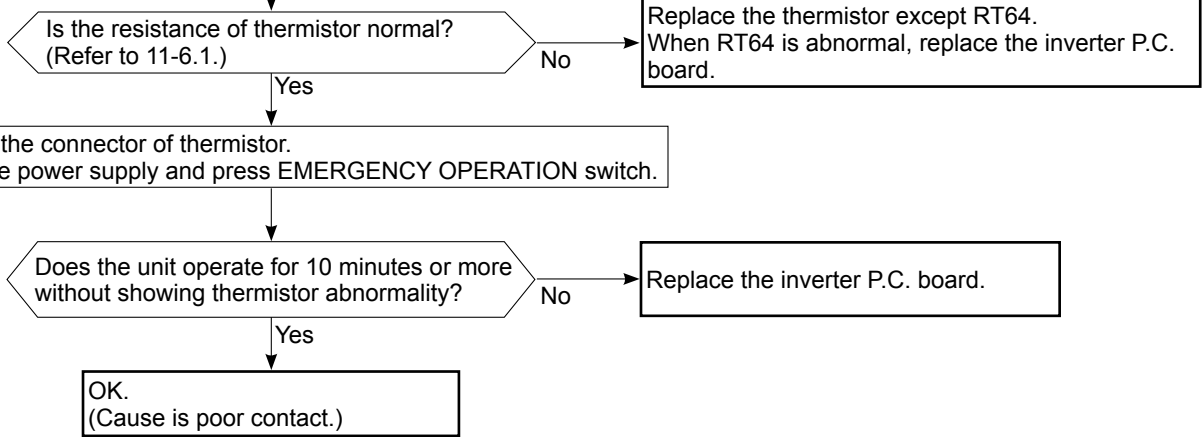

Thermistor	Symbol	Connector, Pin No.	Board
Defrost	RT61	Between CN671 pin1 and pin2	Inverter P.C. board
Discharge temperature	RT62	Between CN671 pin3 and pin4	
Fin temperature	RT64	Between CN673 pin1 and pin2	
Ambient temperature	RT65	Between CN672 pin1 and pin2	
Outdoor heat exchanger temperature	RT68	Between CN671 pin5 and pin6	

### H Check of R.V. coil

- ※ First of all, measure the resistance of R.V. coil to check if the coil is defective. Refer to 11-4.
- ※ In case CN602 is disconnected or R.V. coil is open, voltage is generated between the terminal pins of the connector although no signal is being transmitted to R.V. coil. Check if CN602 is connected.

#### Unit operates COOL mode even if it is set to HEAT mode.

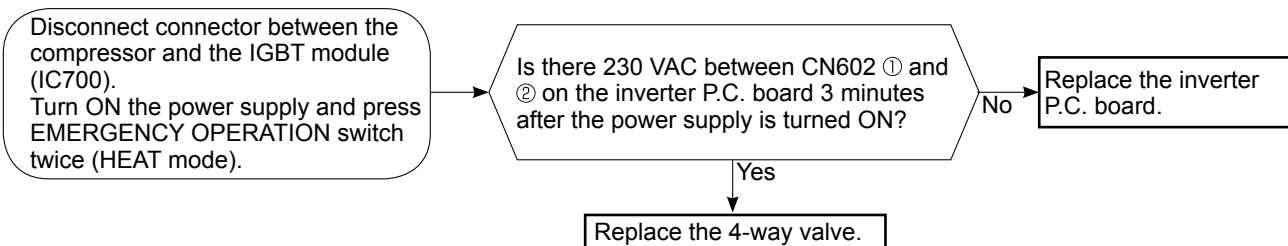

#### Unit operates HEAT mode even if it is set to COOL mode.

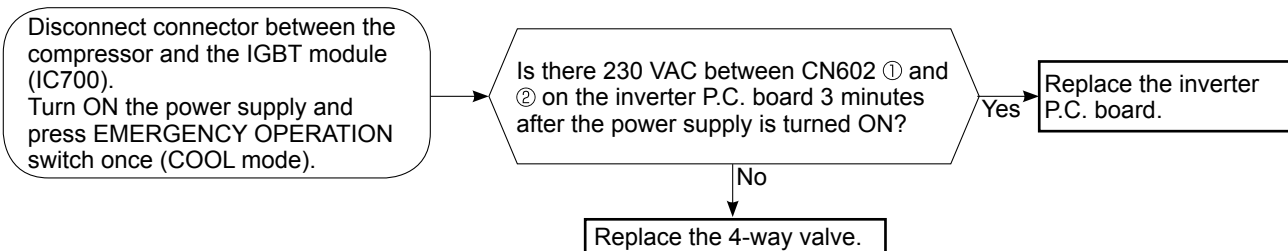



**① Check of outdoor fan motor**

Disconnect the connectors CN931 and CN932 from the inverter P.C. board.  
Check the connection between the connector CN931 and CN932.

Is the resistance between each terminal of outdoor fan motor normal?  
(Refer to 11-4.)

No

Replace the outdoor fan motor.

Yes

Disconnect CN932 from the inverter P.C. board, and turn on the power supply.

Rotate the outdoor fan motor manually and measure the voltage of CN931.  
Between 1(+) and 5(-)  
Between 2(+) and 5(-)  
Between 3(+) and 5(-)

Does the voltage between each terminal become 5 and 0 VDC repeatedly?

No

Does the outdoor fan motor rotate smoothly?

No

Replace the inverter P.C. board.

**J Check of power supply**

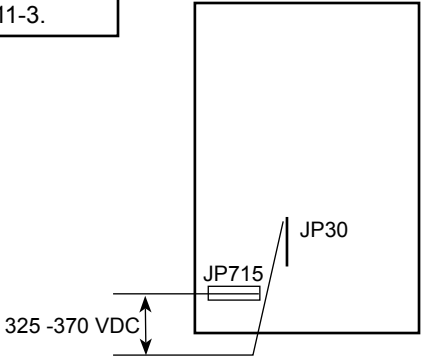
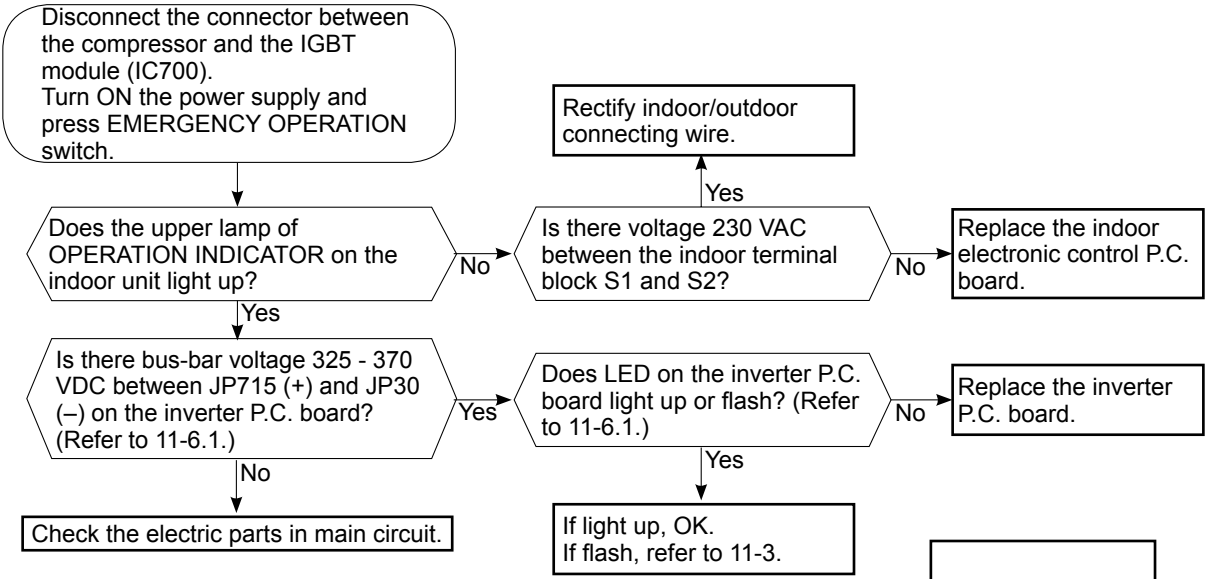



## K Check of LEV (Expansion valve)

Turn ON the power supply.  
 <Preparation of the remote controller>  
 ① While pressing both OPERATION SELECT button and TEMP  $\oplus$  button on the remote controller at the same time, press RESET button.  
 ② First, release RESET button.  
 Hold down the other two buttons for another 3 seconds. Make sure that the indicators on the LCD screen shown in the right figure are all displayed. Then release the buttons.

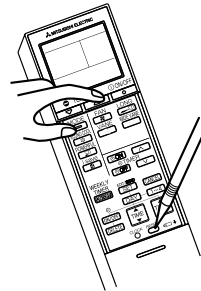

Press OPERATE/STOP (ON/OFF) button of the remote controller (the set temperature is displayed) with the remote controller headed towards the indoor unit. ※1

Expansion valve operates in full-opening direction.

Do you hear the expansion valve "click, click....."?  
 Do you feel the expansion valve vibrate on touching it?

Yes

OK

No

Is LEV coil properly fixed to the expansion valve?

No

Properly fix the LEV coil to the expansion valve.

Yes

Does the resistance of LEV coil have the characteristics? (Refer to 11-4.)

Yes

Measure each voltage between connector pins of CN724 on the inverter P.C. board.  
 1. Pin③(-) — Pin①(+)  
 2. Pin④(-) — Pin①(+)  
 3. Pin⑤(-) — Pin①(+)  
 4. Pin⑥(-) — Pin①(+)  
 Is there about 3 - 5 VAC between each?  
**NOTE:** Measure the voltage by an analog tester.

No

Replace the inverter P.C. board.

Replace the LEV coil.

Yes

Replace the expansion valve.

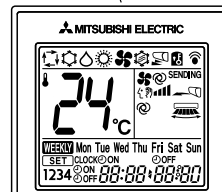

※1. Regardless of normal or abnormal condition, a short beep is emitted once the signal is received.

**NOTE:** After check of LEV, do the undermentioned operations.

1. Turn OFF the power supply and turn it ON again.
2. Press RESET button on the remote controller.

## Ⓛ Check of inverter P.C. board

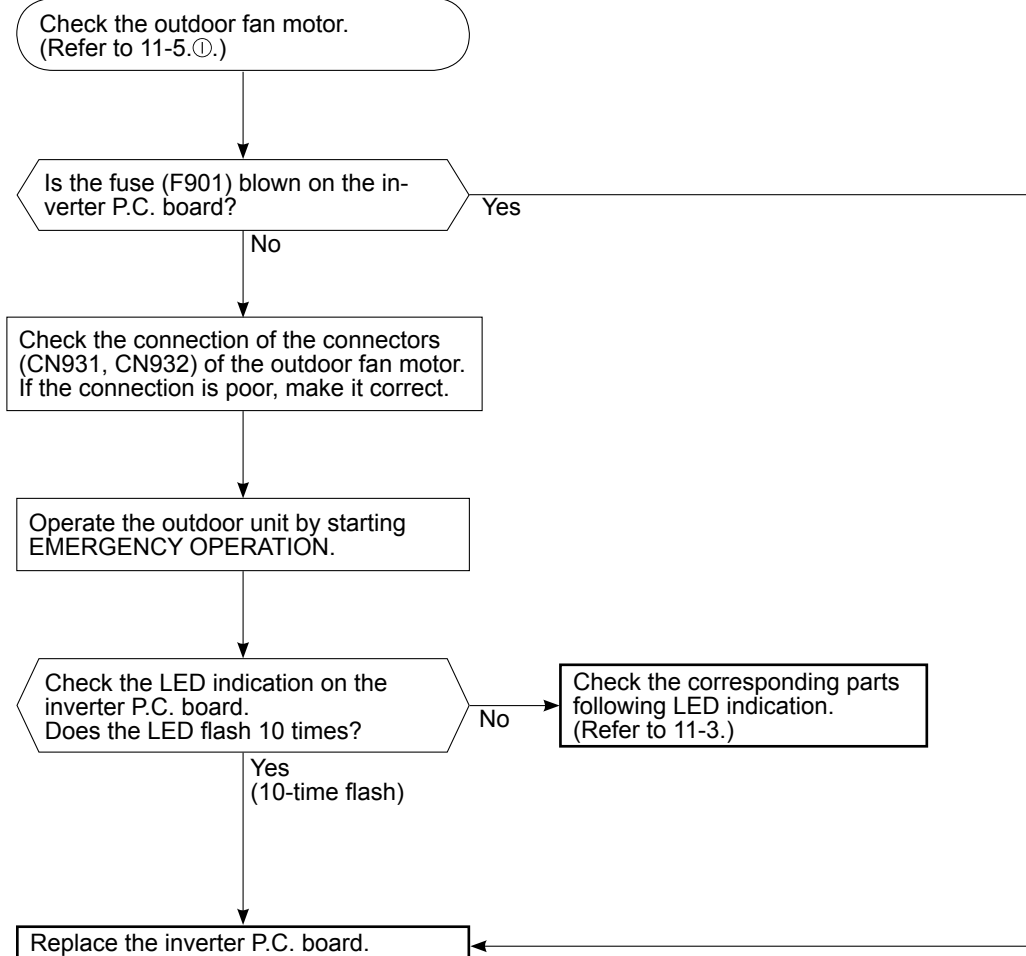

## M How to check miswiring and serial signal error

NOTE: Refer to the indoor unit service manual.

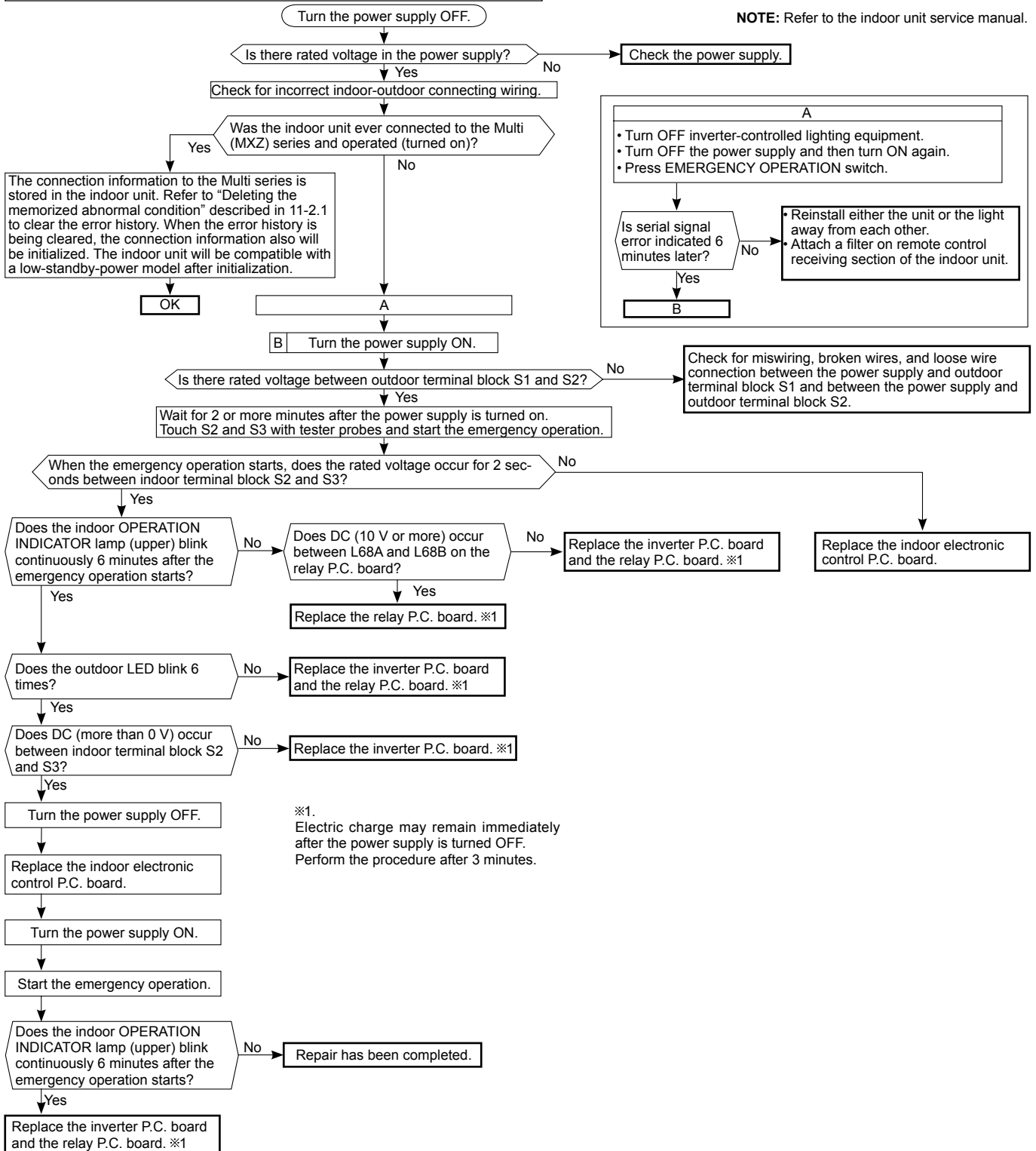

## Ⓝ Electromagnetic noise enters into TV sets or radios

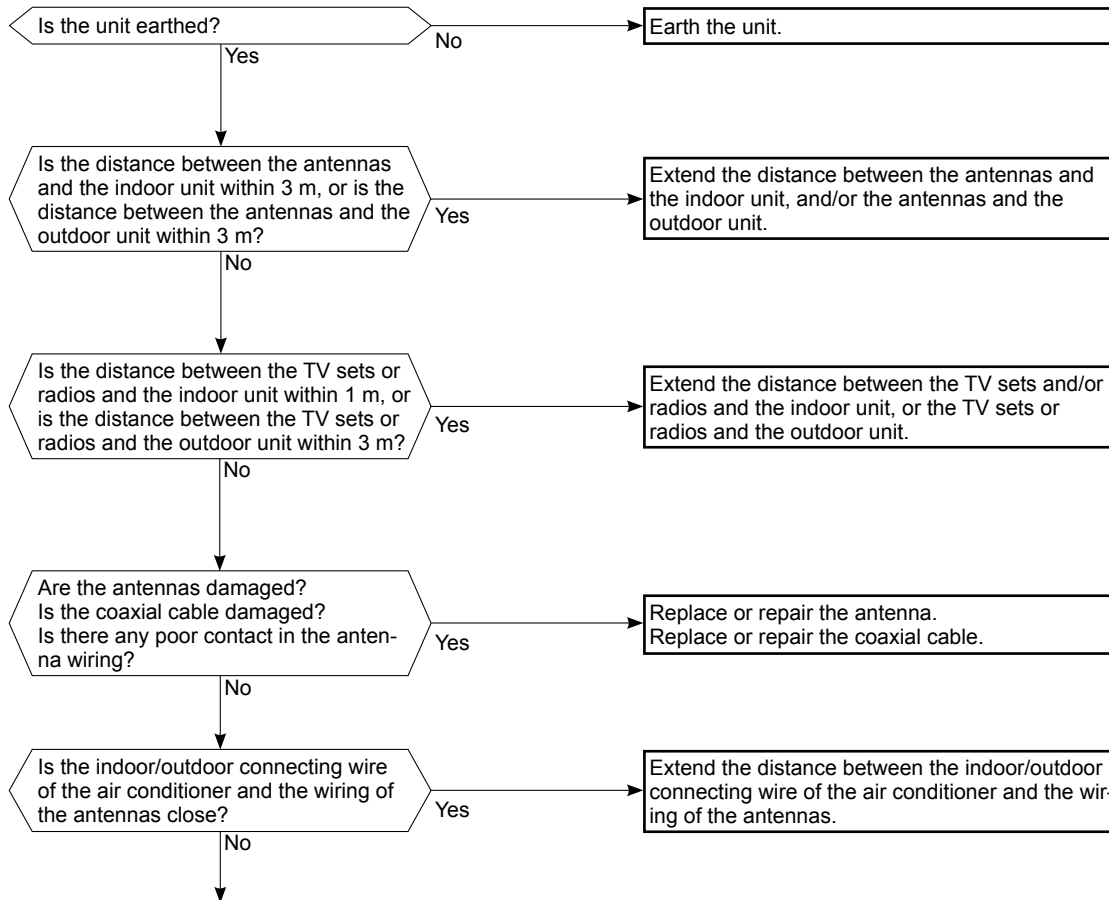

Even if all of the above conditions are fulfilled, the electromagnetic noise may enter, depending on the electric field strength or the installation condition (combination of specific conditions such as antennas or wiring). Check the following before asking for service.

1. Devices affected by the electromagnetic noise  
TV sets, radios (FM/AM broadcast, shortwave)
2. Channel, frequency, broadcast station affected by the electromagnetic noise
3. Channel, frequency, broadcast station unaffected by the electromagnetic noise
4. Layout of:  
indoor/outdoor unit of the air conditioner, indoor/outdoor wiring, earth wire, antennas, wiring from antennas, receiver
5. Electric field intensity of the broadcast station affected by the electromagnetic noise
6. Presence or absence of amplifier such as booster
7. Operation condition of air conditioner when the electromagnetic noise enters in
  - 1) Turn OFF the power supply once, and then turn ON the power supply. In this situation, check for the electromagnetic noise.
  - 2) Within 3 minutes after turning ON the power supply, press OPERATE/STOP (ON/OFF) button on the remote controller for power ON, and check for the electromagnetic noise.
  - 3) After a short time (3 minutes later after turning ON), the outdoor unit starts running. During operation, check for the electromagnetic noise.
  - 4) Press OPERATE/STOP (ON/OFF) button on the remote controller for power OFF, when the outdoor unit stops but the indoor/outdoor communication still runs on. In this situation, check for the electromagnetic noise.

**11-6. TEST POINT DIAGRAM AND VOLTAGE**  
**1. Inverter P.C. board**  
**MUZ-GF60VE MUZ-GF71VE**

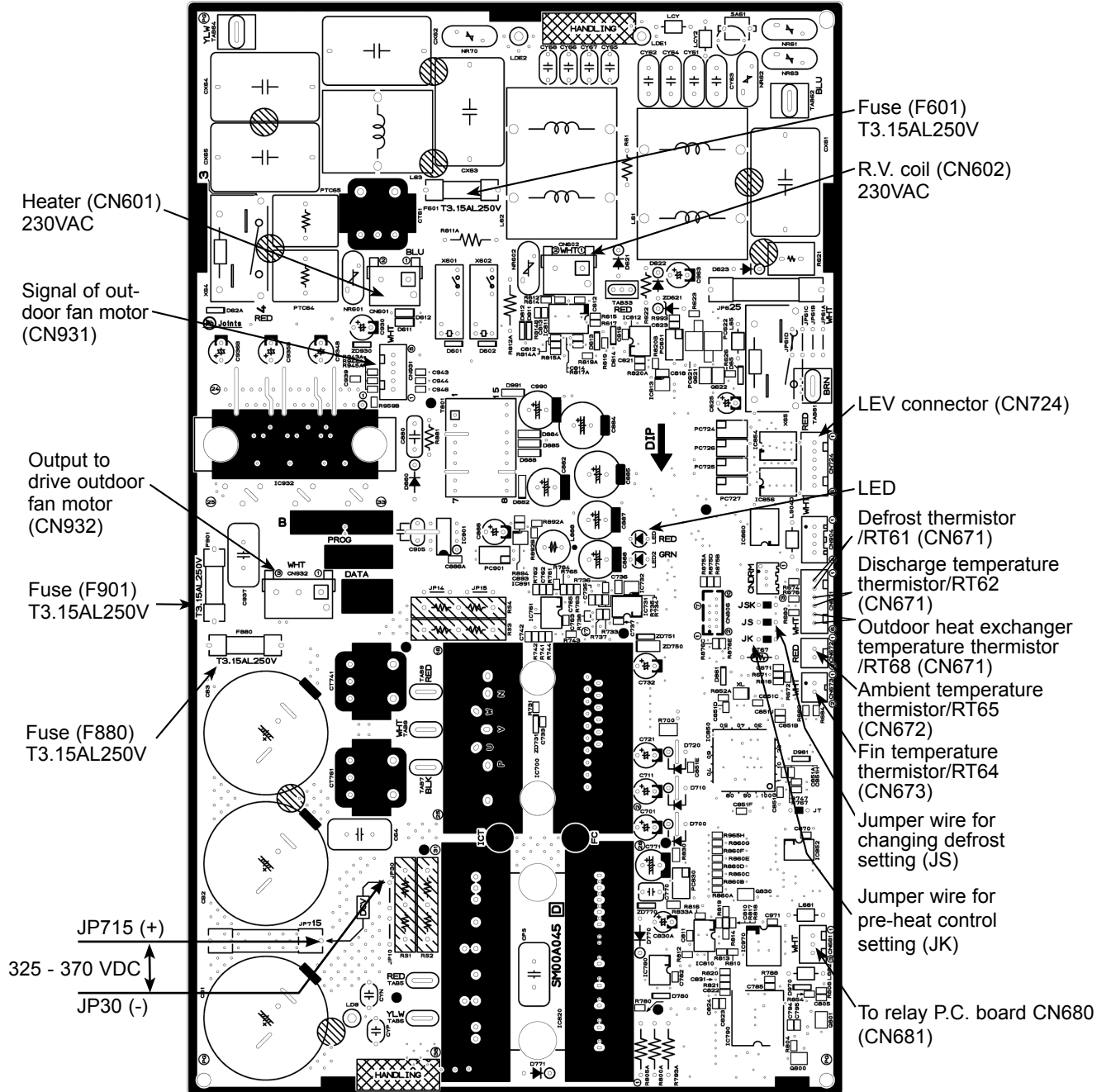

Defrost thermistor (RT61)  
 Ambient temperature thermistor (RT65)  
 Outdoor heat exchanger temperature thermistor (RT68)

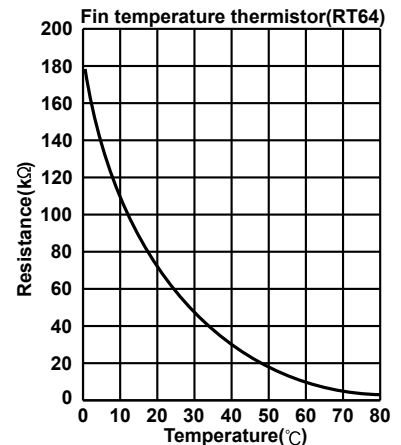
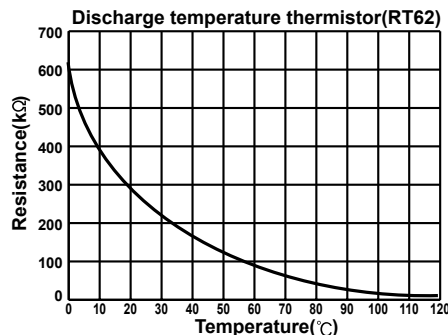
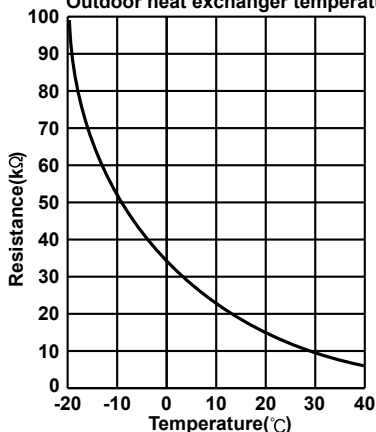

2. Relay P.C. board  
MUZ-GF60VE MUZ-GF71VE

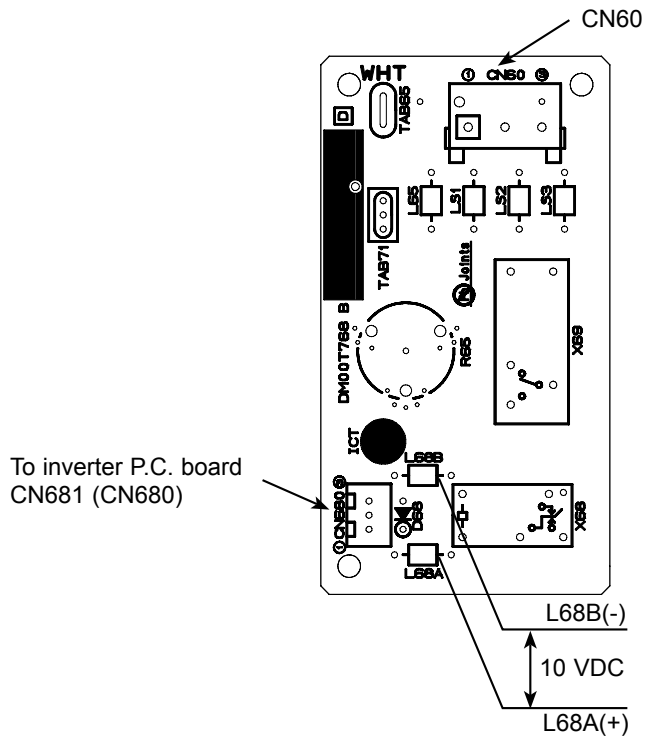

## &lt;"Terminal with locking mechanism" Detaching points&gt;

The terminal which has the locking mechanism can be detached as shown below.  
There are two types (refer to (1) and (2)) of the terminal with locking mechanism.  
The terminal without locking mechanism can be detached by pulling it out.  
Check the shape of the terminal before detaching.

(1) Slide the sleeve and check if there is a locking lever or not.

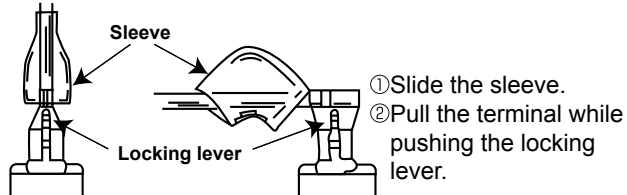

(2) The terminal with this connector has the locking mechanism.

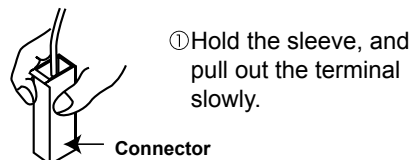

## 12-1. MUZ-GF60VE MUZ-GF71VE

**NOTE:** Turn OFF power supply before disassembly.

OPERATING PROCEDURE	PHOTOS
<p><b>1. Removing the cabinet</b></p> <ol style="list-style-type: none"> <li>(1) Remove the screws of the service panel.</li> <li>(2) Remove the screws of the top panel.</li> <li>(3) Remove the screw of the valve cover.</li> <li>(4) Remove the service panel.</li> <li>(5) Remove the top panel.</li> <li>(6) Remove the valve cover.</li> <li>(7) Disconnect the power supply and indoor/outdoor connecting wire.</li> <li>(8) Remove the screws of the cabinet.</li> <li>(9) Remove the cabinet.</li> <li>(10) Remove the screws of the back panel.</li> <li>(11) Remove the back panel.</li> </ol> <p><b>Photo 2</b></p>	<p><b>Photo 1</b></p>

## OPERATING PROCEDURE

### 2. Removing the inverter assembly, inverter P.C. board and relay P.C. board

- (1) Remove the cabinet and panels. (Refer to 1.)
- (2) Disconnect the lead wire to the reactor and the following connectors:
  - <Inverter P.C. board>
  - CN602 (R.V. coil)
  - CN931, CN932 (Fan motor)
  - CN671 (Defrost thermistor, discharge temperature thermistor and outdoor heat exchanger temperature thermistor)
  - CN672 (Ambient temperature thermistor)
  - CN724 (LEV)
- (3) Remove the compressor connector.
- (4) Remove the screws fixing the relay panel.
- (5) Remove the relay panel.
- (6) Remove the earth wires and the lead wires of the inverter P.C. board.
- (7) Remove the screws of the PB support.
- (8) Remove the inverter P.C. board from the relay panel.
- (9) Disconnect the following connectors:
  - <Relay P.C. board>
  - CN60 (Terminal block)
  - CN680 (Inverter P.C. board)
  - TAB65 (Inverter P.C. board)
  - TB71
- (10) Remove the screws fixing the P.B. holder.
- (11) Remove the relay P.C. board from the P.B. holder.

### 3. Removing R.V. coil

- (1) Remove the cabinet and panels. (Refer to 1.)
- (2) Disconnect the following connector:
  - <Inverter P.C. board>
  - CN602 (R.V. coil)
- (3) Remove the R.V. coil.

## PHOTOS

Photo 3

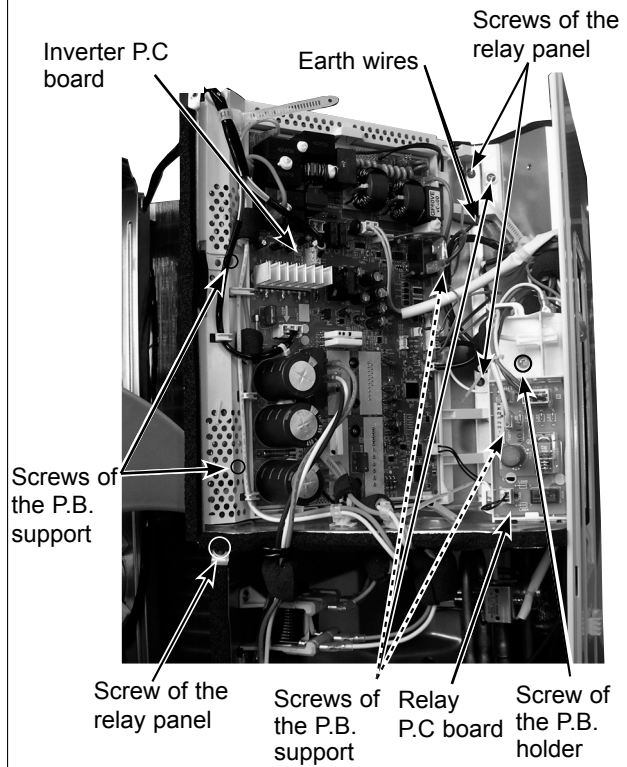

Photo 4





## OPERATING PROCEDURE

### 4. Removing the discharge temperature thermistor, defrost thermistor, outdoor heat exchanger temperature thermistor and ambient temperature thermistor

- (1) Remove the cabinet and panels. (Refer to 1.)
- (2) Disconnect the lead wire to the reactor and the following connectors:  
<Inverter P.C. board>  
CN671 (Defrost thermistor, discharge temperature thermistor and outdoor heat exchanger temperature thermistor)  
CN672 (Ambient temperature thermistor)
- (3) Pull out the discharge temperature thermistor from its holder. (Photo 7)
- (4) Pull out the defrost thermistor from its holder.
- (5) Pull out the outdoor heat exchanger temperature thermistor from its holder.
- (6) Pull out the ambient temperature thermistor from its holder.

### 5. Removing outdoor fan motor

- (1) Remove the top panel, cabinet and service panel. (Refer to 1.)
- (2) Disconnect the following connectors:  
<Inverter P.C. board>  
CN931 and CN932 (Fan motor)
- (3) Remove the propeller.
- (4) Remove the screws fixing the fan motor.
- (5) Remove the fan motor.

### 6. Removing the compressor and 4-way valve

- (1) Remove the top panel, cabinet and service panel. (Refer to 1.)
- (2) Remove the back panel. (Refer to 1.)
- (3) Remove the inverter assembly. (Refer to 2.)
- (4) Recover gas from the refrigerant circuit.  
**NOTE:** Recover gas from the pipes until the pressure gauge shows 0 kg/cm<sup>2</sup> (0 MPa).
- (5) Detach the brazed part of the suction and the discharge pipe connected with compressor.
- (6) Remove the compressor nuts.
- (7) Remove the compressor.
- (8) Detach the brazed parts of 4-way valve and pipe. (Photo 4)

## PHOTOS

Photo 5

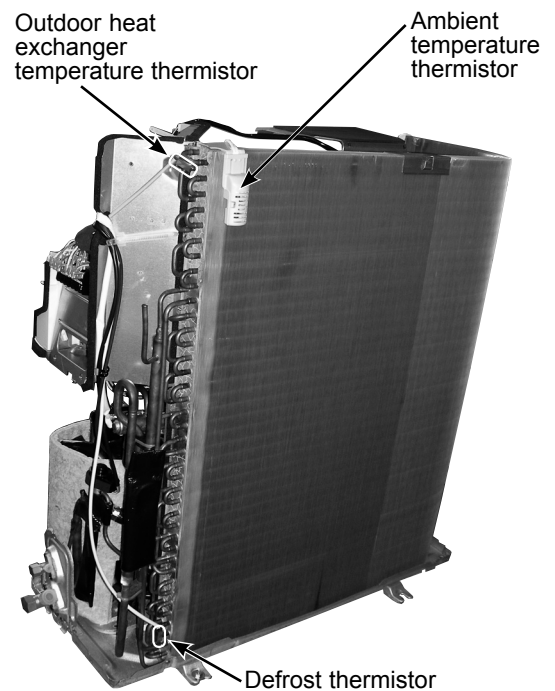

Photo 6

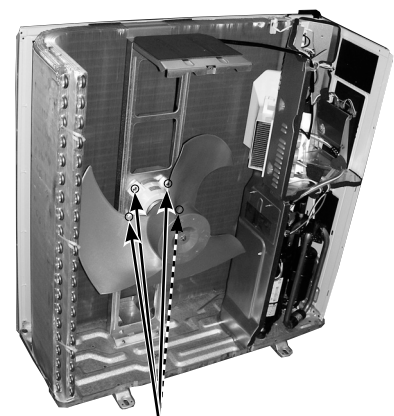
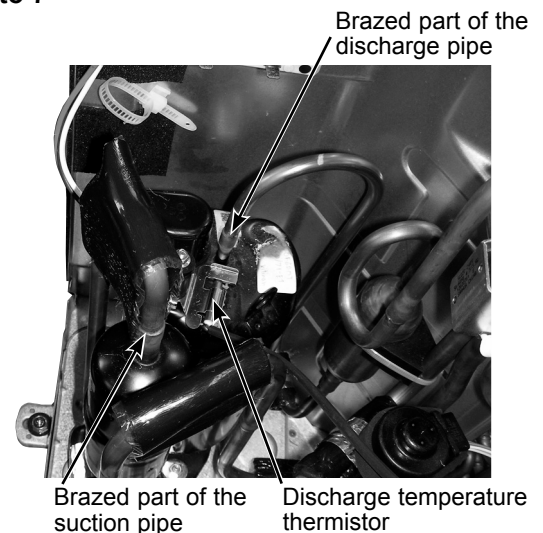

Photo 7



# **mitsubishi electric corporation**

HEAD OFFICE: TOKYO BLDG., 2-7-3, MARUNOUCHI, CHIYODA-KU, TOKYO 100-8310, JAPAN

© Copyright 2013 MITSUBISHI ELECTRIC CORPORATION  
Distributed in Mar. 2013. No. OBH635  
Made in Japan

New publication, effective Mar. 2013  
Specifications are subject to change without notice.