

# TECHNICAL & SERVICE MANUAL

## Series PCA Ceiling Suspended R407C/R410A

**Indoor unit  
[Model names]**

PCA-RP2GA  
 PCA-RP2.5GA  
 PCA-RP3GA  
 PCA-RP4GA  
 PCA-RP5GA  
 PCA-RP6GA

**[Service Ref.]**

**PCA-RP2GA  
 PCA-RP2.5GA  
 PCA-RP3GA  
 PCA-RP4GA  
 PCA-RP5GA  
 PCA-RP6GA**

**NOTE:**

- This manual does not cover outdoor units. When serving them, please refer to the service manual No.OC261 REVISED EDITION-B, OC285, OC294 REVISED EDITION-B, OC298 and this manual in a set.

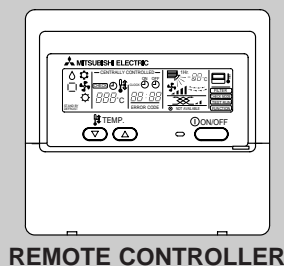
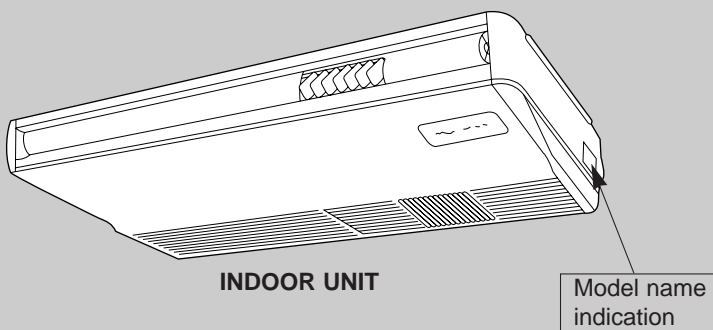

### CONTENTS

1. COMBINATION OF INDOOR AND OUTDOOR UNITS ..2	
2. SAFETY PRECAUTION .....	3
3. PART NAMES AND FUNCTIONS.....	7
4. SPECIFICATIONS .....	9
5. DATA.....	18
6. OUTLINES AND DIMENSIONS .....	50
7. WIRING DIAGRAM.....	54
8. REFRIGERANT SYSTEM DIAGRAM .....	55
9. TROUBLESHOOTING .....	56
10. DISASSEMBLY PROCEDURE .....	66
11. PARTS LIST .....	71
12. OPTIONAL PARTS .....	78

# 1 COMBINATION OF INDOOR AND OUTDOOR UNITS

(R410A Inverter)

Indoor unit	Outdoor unit [OC294 REVISED EDITION-B]					
	Heat pump type					
	PUHZ-RP					
	2VHA	2.5VHA	3VHA	4VHA 4VHA <sub>1</sub>	5VHA 5VHA <sub>1</sub>	6VHA 6VHA <sub>1</sub>
PCA-RP2GA	○	—	—	—	—	—
PCA-RP2.5GA	—	○	—	—	—	—
PCA-RP3GA	—	—	○	—	—	—
PCA-RP4GA	—	—	—	○	—	—
PCA-RP5GA	—	—	—	—	○	—
PCA-RP6GA	—	—	—	—	—	○

(R407C Fixed speed)

	Indoor unit	Outdoor unit [OC285]						Outdoor unit [OC298]							
		Heat pump type						Cooling only type							
		PUH-P						PU-P							
		2	2.5	3		4	5	6	2	2.5	3		4	5	6
VGAA	VGAA	VGAA	YGAA	YGAA	YGAA	YGAA	VGAA	VGAA	VGAA	YGAA	YGAA	YGAA	YGAA	YGAA	
Heat pump without electric heater or Cooling only	PCA-RP2GA	○	—	—	—	—	—	—	○	—	—	—	—	—	—
	PCA-RP2.5GA	—	○	—	—	—	—	—	—	○	—	—	—	—	—
	PCA-RP3GA	—	—	○	○	—	—	—	—	—	○	○	—	—	—
	PCA-RP4GA	—	—	—	—	○	—	—	—	—	—	—	○	—	—
	PCA-RP5GA	—	—	—	—	—	○	—	—	—	—	—	—	○	—
	PCA-RP6GA	—	—	—	—	—	—	○	—	—	—	—	—	—	○

(R407C Fixed speed)

	Indoor unit	Outdoor unit [OC261 REVISED EDITION-B]																	
		Heat pump type							Cooling only type										
		PUH-P · .UK							PU-P · .UK										
		2		2.5		3		4	5	6	2		2.5		3		4	5	6
VGAA	YGAA	VGAA	YGAA	VGAA	YGAA	VGAA	YGAA	YGAA	YGAA	VGAA	YGAA	VGAA	YGAA	VGAA	YGAA	VGAA	YGAA	YGAA	
VGAA <sub>1</sub>	YGAA <sub>1</sub>	VGAA <sub>1</sub>	YGAA <sub>1</sub>	VGAA <sub>1</sub>	YGAA <sub>1</sub>	VGAA <sub>1</sub>	YGAA <sub>1</sub>	YGAA <sub>1</sub>	YGAA <sub>1</sub>	VGAA <sub>1</sub>	YGAA <sub>1</sub>	VGAA <sub>1</sub>	YGAA <sub>1</sub>	VGAA <sub>1</sub>	YGAA <sub>1</sub>	VGAA <sub>1</sub>	YGAA <sub>1</sub>	YGAA <sub>1</sub>	
Heat pump without electric heater or Cooling only	PCA-RP2GA	○	○	—	—	—	—	—	—	—	—	○	○	—	—	—	—	—	—
	PCA-RP2.5GA	—	—	○	○	—	—	—	—	—	—	—	○	○	—	—	—	—	—
	PCA-RP3GA	—	—	—	—	○	○	—	—	—	—	—	—	—	○	○	—	—	—
	PCA-RP4GA	—	—	—	—	—	—	○	○	—	—	—	—	—	—	—	○	○	—
	PCA-RP5GA	—	—	—	—	—	—	—	—	○	—	—	—	—	—	—	—	—	○
	PCA-RP6GA	—	—	—	—	—	—	—	—	—	○	—	—	—	—	—	—	—	—

## CAUTIONS RELATED TO NEW REFRIGERANT

Cautions for units utilising refrigerant R407C

**Do not use the existing refrigerant piping.**

The old refrigerant and lubricant in the existing piping contains a large amount of chlorine which may cause the lubricant deterioration of the new unit.

**Use "low residual oil piping"**

If there is a large amount of residual oil (hydraulic oil, etc.) inside the piping and joints, deterioration of the lubricant will result.

**Store the piping to be used during installation indoors with keep both ends sealed until just before brazing.  
(Store elbows and other joints in a plastic bag.)**

If dust, dirt, or water enters the refrigerant cycle, deterioration of the oil and compressor trouble may result.

**Use ESTR , ETHER or HAB as the lubricant to coat flares and flange connection parts.**

If large amount of mineral oil enter, that can cause deterioration of refrigerant oil etc.

**Use liquid refrigerant to charge the system.**

If gas refrigerant is used to seal the system, the composition of the refrigerant in the cylinder will change and performance may drop.

**Do not use a refrigerant other than R407C.**

If another refrigerant (R22, etc.) is used, the chlorine in the refrigerant may cause the lubricant deterioration.

**Use a vacuum pump with a reverse flow check valve.**

The vacuum pump oil may flow back into the refrigerant cycle and cause the lubricant deterioration.

**Ventilate the room if refrigerant leaks during operation. If refrigerant comes into contact with a flame, poisonous gases will be released.****[1] Cautions for service**

- After recovering the all refrigerant in the unit, proceed to working.
- Do not release refrigerant in the air.
- After completing the repair service, recharge the cycle with the specified amount of liquid refrigerant.

**[2] Refrigerant recharging**

## (1) Refrigerant recharging process

## ①Direct charging from the cylinder.

- R407C cylinder are available on the market has a syphon pipe.
- Leave the syphon pipe cylinder standing and recharge it.  
(By liquid refrigerant)

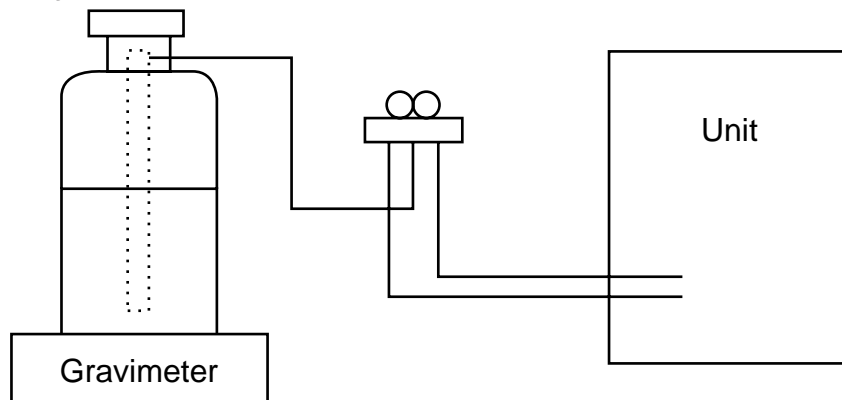

## (2) Recharge in refrigerant leakage case

- After recovering the all refrigerant in the unit, proceed to working.
- Do not release the refrigerant in the air.
- After completing the repair service, recharge the cycle with the specified amount of liquid refrigerant.

### [3] Service tools

Use the below service tools as exclusive tools for R407C refrigerant.

No.	Tool name	Specifications
①	Gauge manifold	·Only for R407C.
		·Use the existing fitting SPECIFICATIONS. (UNF7/16)
		·Use high-tension side pressure of 3.43MPa-G or over.
②	Charge hose	·Only for R407C.
		·Use pressure performance of 5.10MPa-G or over.
③	Electronic scale	
④	Gas leak detector	·Use the detector for R134a or R407C.
⑤	Adapter for reverse flow check.	·Attach on vacuum pump.
⑥	Refrigerant charge base.	
⑦	Refrigerant cylinder.	·For R407C      ·Top of cylinder (Brown)
		·Cylinder with syphon
⑧	Refrigerant recovery equipment.	

## CAUTIONS RELATED TO NEW REFRIGERANT

### Cautions for units utilising refrigerant R410A

#### Use new refrigerant pipes.

In case of using the existing pipes for R22, be careful with the followings.

- For RP4 ,5 and 6, be sure to perform replacement operation before test run.
- Change flare nut to the one provided with this product. Use a newly flared pipe.
- Avoid using thin pipes.

**Make sure that the inside and outside of refrigerant piping is clean and it has no contamination such as sulfur hazardous for use, oxides, dirt, shaving particles, etc. In addition, use pipes with specified thickness.**

Contamination inside refrigerant piping can cause deterioration of refrigerant oil etc.

**Store the piping to be used during installation indoors and keep both ends of the piping sealed until just before brazing. (Leave elbow joints, etc. in their packaging.)**

If dirt, dust or moisture enter into refrigerant cycle, that can cause deterioration of refrigerant oil or malfunction of compressor.

**Use ester oil, ether oil or alkylbenzene oil (small amount) as the refrigerant oil applied to flares and flange connections.**

If large amount of mineral oil enter, that can cause deterioration of refrigerant oil etc.

**Charge refrigerant from liquid phase of gas cylinder.**

If the refrigerant is charged from gas phase, composition change may occur in refrigerant and the efficiency will be lowered.

**Do not use refrigerant other than R410A.**

If other refrigerant (R22 etc.) is used, chlorine in refrigerant can cause deterioration of refrigerant oil etc.

**Use a vacuum pump with a reverse flow check valve.**

Vacuum pump oil may flow back into refrigerant cycle and that can cause deterioration of refrigerant oil etc.

**Use the following tools specifically designed for use with R410A refrigerant.**

The following tools are necessary to use R410A refrigerant.

Tools for R410A	
Gauge manifold	Flare tool
Charge hose	Size adjustment gauge
Gas leak detector	Vacuum pump adaptor
Torque wrench	Electronic refrigerant charging scale

**Keep the tools with care.**

If dirt, dust or moisture enter into refrigerant cycle, that can cause deterioration of refrigerant oil or malfunction of compressor.

**Do not use a charging cylinder.**

If a charging cylinder is used, the composition of refrigerant will change and the efficiency will be lowered.

**Ventilate the room if refrigerant leaks during operation. If refrigerant comes into contact with a flame, poisonous gases will be released.**

### [1] Cautions for service

- (1) Perform service after collecting the refrigerant left in unit completely.
- (2) Do not release refrigerant in the air.
- (3) After completing service, charge the cycle with specified amount of refrigerant.
- (4) When performing service, install a filter drier simultaneously.  
Be sure to use a filter drier for new refrigerant.

### [2] Additional refrigerant charge

**When charging directly from cylinder**

- Check that cylinder for R410A on the market is syphon type.
- Charging should be performed with the cylinder of syphon stood vertically. (Refrigerant is charged from liquid phase.)

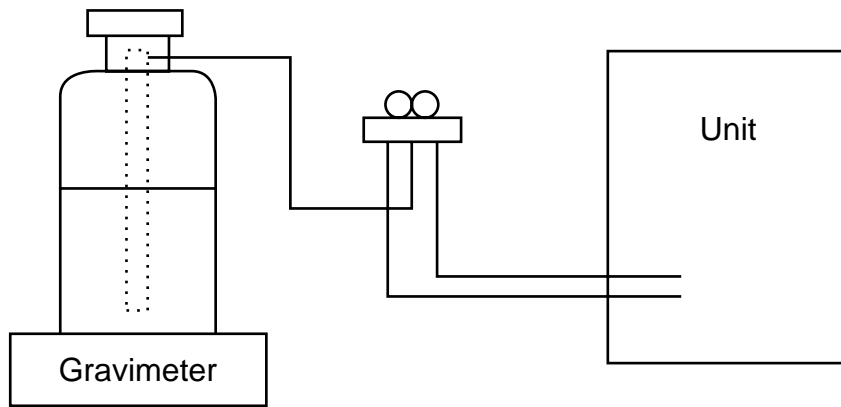

### [3] Service tools

Use the below service tools as exclusive tools for R410A refrigerant.

No.		Specifications
①	Gauge manifold	·Only for R410A
		·Use the existing fitting specifications. (UNF1/2)
		·Use high-tension side pressure of 5.3MPa-G or over.
②	Charge hose	·Only for R410A
		·Use pressure performance of 5.09MPa-G or over.
③	Electronic scale	—
④	Gas leak detector	·Use the detector for R134a, R407C or R410A.
⑤	Adaptor for reverse flow check	·Attach on vacuum pump.
⑥	Refrigerant charge base	—
⑦	Refrigerant cylinder	·Only for R410A    Top of cylinder (Pink)
		Cylinder with syphon
⑧	Refrigerant recovery equipment	—

# 3

# PART NAMES AND FUNCTIONS

## ● Indoor Unit

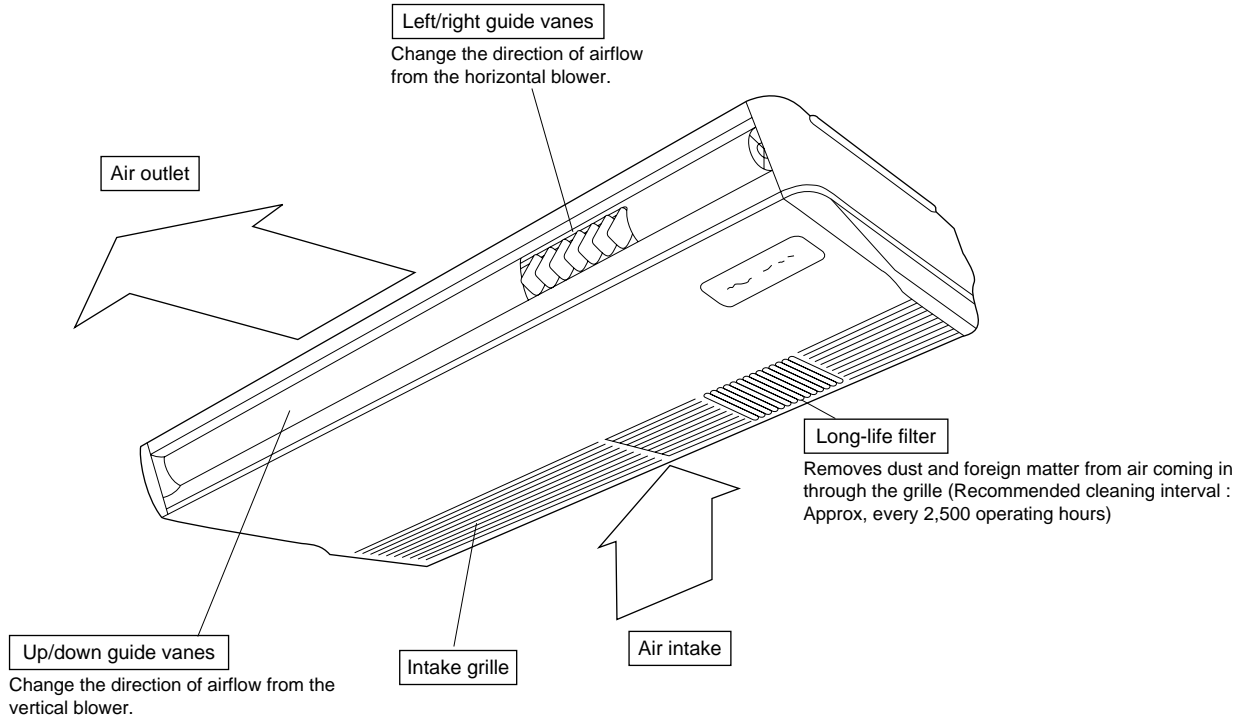

## ● Remote controller

Once the controls are set, the same operation mode can be repeated by simply pressing the ON/OFF button.

## ● Operation buttons

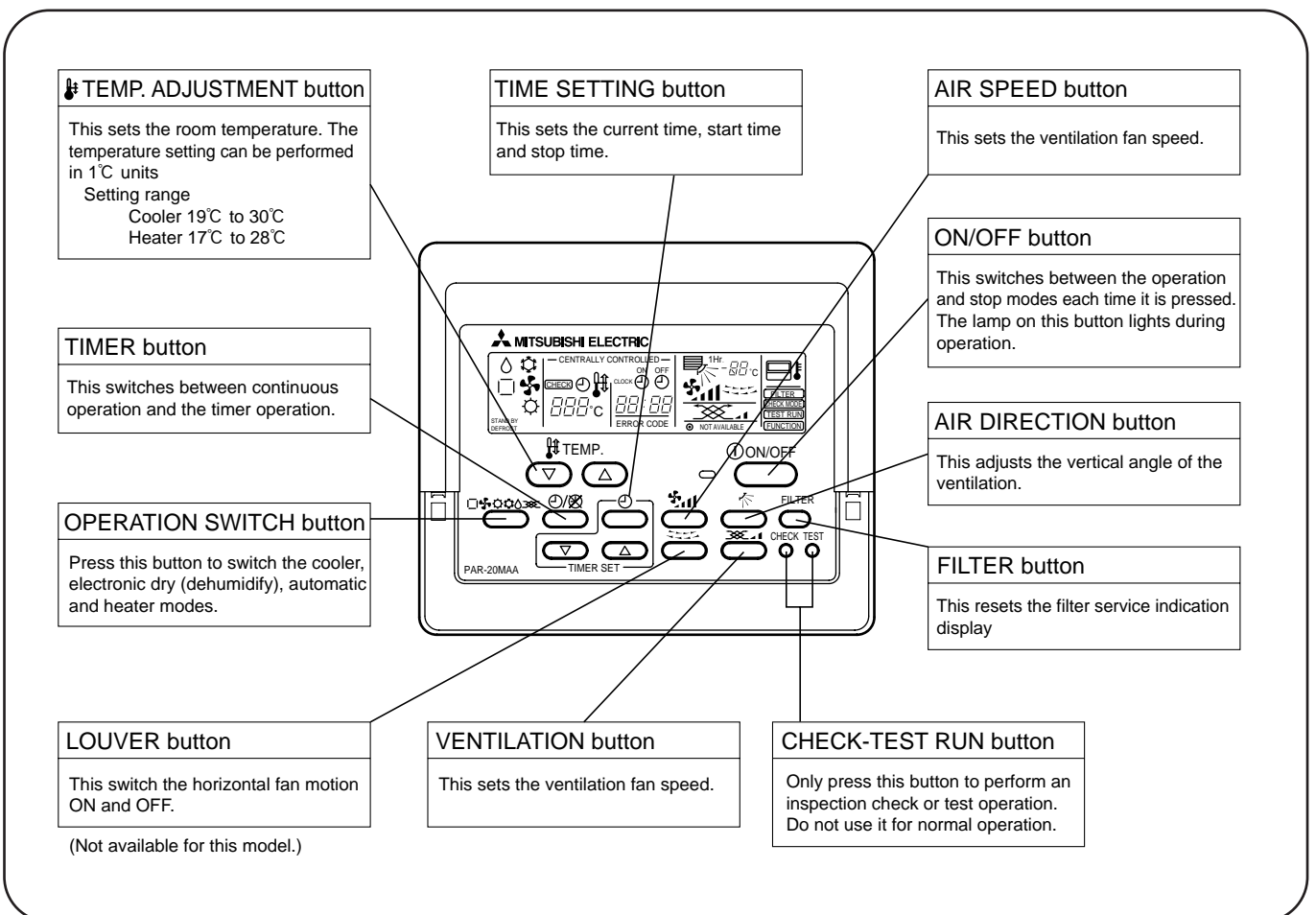

## ● Display

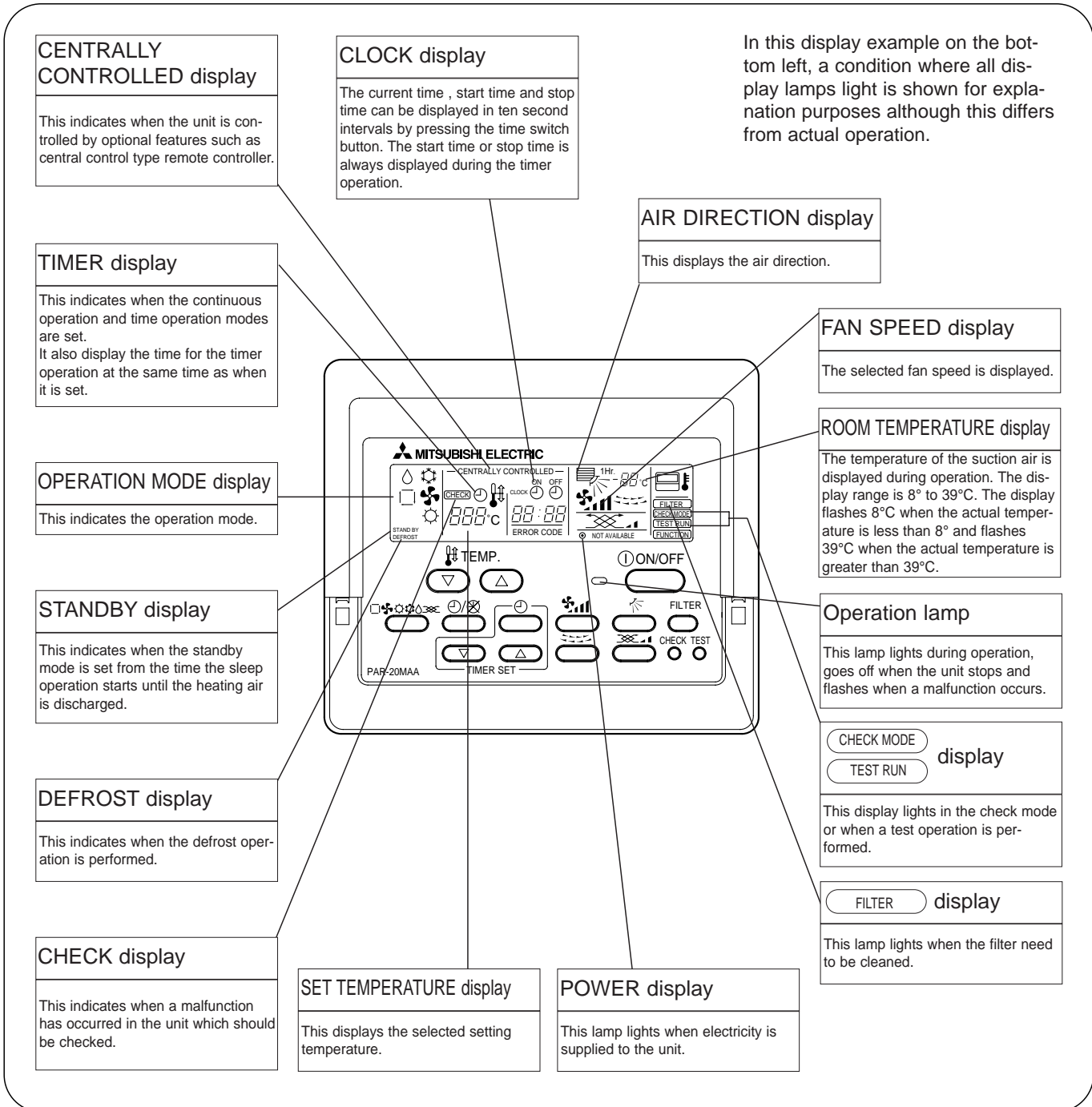

### Caution

- Only the Power display lights when the unit is stopped and power supplied to the unit.
- When power is turned ON for the first time the (CENTRAL CTRL) display appears to go off momentarily but this is not a malfunction.
- When the central control remote control unit, which is sold separately, is used the ON-OFF button, operation switch button and TEMP. adjustment button do not operate.
- "NOT AVAILABLE" is displayed when the Air speed button is pressed. This indicates that this room unit is not equipped with the fan direction adjustment function and the louver function.
- When power is turned ON for the first time, it is normal that "H0" is displayed on the room temperature indication (For max. 2minutes). Please wait until this "H0" indication disappear then start the operation.



# 4

# SPECIFICATIONS

## 4-1. Heat pump type (1)

Item		Service Ref.	PCA-RP2GA	
Function			Cooling	Heating
Capacity		Btu/h	16,000	18,800
		W	4,700(2,300~5,400)	5,500(2,500~6,600)
Total input		kW	1.67	1.71
<b>Service Ref.</b>			<b>PCA-RP2GA</b>	
Power supply(phase, cycle, voltage)			Single phase, 50Hz, 220-230-240V	
INDOOR UNIT	Input	kW	0.09	0.09
	Running current	A	0.41	0.41
	Starting current	A	1.20	1.20
External finish			Munsell 0.70Y 8.59/0.97	
Heat exchanger			Plate fin coil	
INDOOR UNIT	Fan	Fan(drive) x No.	Sirocco fan (direct) x 2	
		Fan motor output	0.054	
		Airflow(Low-Med2-Med1-High)	m <sup>3</sup> /min(CFM) 10-11-12-13(355-390-425-460)	
		External static pressure	Pa(mmAq) 0(direct blow)	
Operation control & Thermostat			Remote controller & built-in	
Noise level(Low-Med2-Med1-High)		dB	37-38-40-42	
Unit drain pipe O.D.		mm(in.)	26(1)	
INDOOR UNIT	Dimensions	W	mm(in.) 1,000(39-3/8)	
		D	mm(in.) 680(26-3/4)	
		H	mm(in.) 210(8-1/4)	
Weight		kg(lbs)	27(60)	
OUTDOOR UNIT	<b>Service Ref.</b>		<b>PUHZ-RP2VHA</b>	

Item		Service Ref.	PCA-RP2.5GA	
Function			Cooling	Heating
Capacity		Btu/h	20,500	23,900
		W	6,000(2,700~6,700)	7,000(2,800~8,200)
Total input		kW	1.63	2.03
<b>Service Ref.</b>			<b>PCA-RP2.5GA</b>	
Power supply(phase, cycle, voltage)			Single phase, 50Hz, 220-230-240V	
INDOOR UNIT	Input	kW	0.12	0.12
	Running current	A	0.53	0.53
	Starting current	A	1.27	1.27
External finish			Munsell 0.70Y 8.59/0.97	
Heat exchanger			Plate fin coil	
INDOOR UNIT	Fan	Fan(drive) x No.	Sirocco fan (direct) x 3	
		Fan motor output	0.070	
		Airflow(Low-Med2-Med1-High)	m <sup>3</sup> /min(CFM) 14-15-16-18(495-530-565-635)	
		External static pressure	Pa(mmAq) 0(direct blow)	
Operation control & Thermostat			Remote controller & built-in	
Noise level(Low-Med2-Med1-High)		dB	37-39-41-43	
Unit drain pipe O.D.		mm(in.)	26(1)	
INDOOR UNIT	Dimensions	W	mm(in.) 1,310(51-9/16)	
		D	mm(in.) 680(26-3/4)	
		H	mm(in.) 210(8-1/4)	
Weight		kg(lbs)	34(75)	
OUTDOOR UNIT	<b>Service Ref.</b>		<b>PUHZ-RP2.5VHA</b>	

Notes1. Rating Conditions (ISO T1)

Cooling : Indoor : D.B. 27°C(80°F), W.B. 19°C (66°F)      Outdoor : D.B. 35°C(95°F), W.B. 24°C (75°F)  
 Heating : Indoor : D.B. 20°C(68°F)      Outdoor : D.B. 7°C(45°F), W.B. 6°C (43°F)  
 Refrigerant piping length (one way) : 5m (16ft)

2. Guaranteed operating range

		Indoor	Outdoor
Cooling	Upper limit	D.B. 35°C, W.B. 22.5°C	D.B. 46°C
	Lower limit	D.B. 19°C, W.B. 15°C	D.B. -5°C
Heating	Upper limit	D.B. 28°C	D.B. 21°C, W.B. 15°C
	Lower limit	D.B. 17°C	D.B. -11°C, W.B. -12°C

3. Guaranteed voltage

198~264V, 50Hz

4. Above data based on indicated voltage  
 Indoor Unit Single phase 230V 50Hz  
 Outdoor Unit Single phase 230V 50Hz

5. Refer to the service manual of outdoor unit for the outdoor unit's specifications.



Item		Service Ref.	PCA-RP3GA	
Function			Cooling	Heating
Capacity		Btu/h	24,200	27,300
		W	7,100(3,300~8,100)	8,000(3,500~10,200)
Total input		kW	2.14	2.43
<b>Service Ref.</b>			<b>PCA-RP3GA</b>	
Power supply(phase, cycle, voltage)			Single phase, 50Hz, 220-230-240V	
Input		kW	0.12	0.12
Running current		A	0.53	0.53
Starting current		A	1.27	1.27
External finish			Munsell 0.70Y 8.59/0.97	
Heat exchanger			Plate fin coil	
INDOOR UNIT	Fan	Fan(drive) x No.	Sirocco fan (direct) x 3	
		Fan motor output	0.070	
		Airflow(Low-Med2-Med1-High)	m <sup>3</sup> /min(CFM) 14-15-16-18(495-530-565-635)	
		External static pressure	Pa(mmAq) 0(direct blow)	
	Operation control & Thermostat			Remote controller & built-in
Noise level(Low-Med2-Med1-High)		dB	37-39-41-43	
Unit drain pipe O.D.		mm(in.)	26(1)	
Dimensions		W	mm(in.) 1,310(51-9/16)	
		D	mm(in.) 680(26-3/4)	
		H	mm(in.) 210(8-1/4)	
Weight		kg(lbs)	34(75)	
OUTDOOR UNIT	<b>Service Ref.</b>		<b>PUHZ-RP3VHA</b>	

Item		Service Ref.	PCA-RP4GA	
Function			Cooling	Heating
Capacity		Btu/h	34,100	27,300
		W	10,000(5,000~11,400)	11,200(5,600~14,000)
		W	10,000(4,500~11,400)	11,200(4,500~14,000)
Total input		kW	2.92	3.26
<b>Service Ref.</b>			<b>PCA-RP4GA</b>	
Power supply(phase, cycle, voltage)			Single phase, 50Hz, 220-230-240V	
Input		kW	0.15	0.15
Running current		A	0.69	0.69
Starting current		A	1.48	1.48
External finish			Munsell 0.70Y 8.59/0.97	
Heat exchanger			Plate fin coil	
INDOOR UNIT	Fan	Fan(drive) x No.	Sirocco fan (direct) x 3	
		Fan motor output	0.090	
		Airflow(Low-Med2-Med1-High)	m <sup>3</sup> /min(CFM) 20-21-23-25(705-740-810-885)	
		External static pressure	Pa(mmAq) 0(direct blow)	
	Operation control & Thermostat			Remote controller & built-in
Noise level(Low-Med2-Med1-High)		dB	40-41-43-45	
Unit drain pipe O.D.		mm(in.)	26(1)	
Dimensions		W	mm(in.) 1,310(51-9/16)	
		D	mm(in.) 680(26-3/4)	
		H	mm(in.) 270(10-5/8)	
Weight		kg(lbs)	37(82)	
OUTDOOR UNIT	<b>Service Ref.</b>		<b>PUHZ-RP4VHA PUHZ-RP4VHA<sub>1</sub></b>	

Notes 1. Rating Conditions (ISO T1)

Cooling : Indoor : D.B. 27°C(80°F), W.B. 19°C (66°F) Outdoor : D.B. 35°C(95°F), W.B. 24°C (75°F)  
 Heating : Indoor : D.B. 20°C(68°F) Outdoor : D.B. 7°C(45°F), W.B. 6°C (43°F)  
 Refrigerant piping length (one way) : 5m (16ft)

2. Guaranteed operating range

		Indoor	Outdoor
Cooling	Upper limit	D.B. 35°C, W.B. 22.5°C	D.B. 46°C
	Lower limit	D.B. 19°C, W.B. 15°C	D.B. -5°C
Heating	Upper limit	D.B. 28°C	D.B. 21°C, W.B. 15°C
	Lower limit	D.B. 17°C	D.B. -11°C, W.B. -12°C

3. Guaranteed voltage  
198~264V, 50Hz

4. Above data based on indicated voltage  
 Indoor Unit Single phase 230V 50Hz  
 Outdoor Unit Single phase 230V 50Hz

5. Refer to the service manual of outdoor unit for the outdoor unit's specifications.

Item		Service Ref.	PCA-RP5GA	
Function			Cooling	Heating
		Btu/h	42,700	47,800
Capacity	PUHZ-RP5VHA	W	12,500(6,000~14,000)	14,000(6,000~16,000)
	PUHZ-RP5VHA <sub>1</sub>	W	12,500(5,500~14,000)	14,000(5,000~16,000)
Total input		kW	3.89	4.34
<b>Service Ref.</b>			<b>PCA-RP5GA</b>	
Power supply(phase, cycle, voltage)			Single phase, 50Hz, 220-230-240V	
Input		kW	0.22	0.22
Running current		A	1.01	1.01
Starting current		A	2.20	2.20
External finish			Munsell 0.70Y 8.59/0.97	
Heat exchanger			Plate fin coil	
INDOOR UNIT	Fan	Fan(drive) x No.	Sirocco fan (direct) x 4	
		Fan motor output	0.150	
		Airflow(Low-Med2-Med1-High)	m <sup>3</sup> /min(CFM) 27-30-32-34(955-1,060-1,130-1,200)	
		External static pressure	Pa(mmAq) 0(direct blow)	
Operation control & Thermostat			Remote controller & built-in	
Noise level(Low-Med2-Med1-High)		dB	41-43-45-46	
Unit drain pipe O.D.		mm(in.)	26(1)	
Dimensions	W	mm(in.)	1,620(63-3/4)	
	D	mm(in.)	680(26-3/4)	
	H	mm(in.)	270(10-5/8)	
Weight		kg(lbs)	43(95)	
OUTDOOR UNIT	<b>Service Ref.</b>		<b>PUHZ-RP5VHA PUHZ-RP5VHA<sub>1</sub></b>	

Item		Service Ref.	PCA-RP6GA	
Function			Cooling	Heating
		Btu/h	47,800	54,600
Capacity	PUHZ-RP6VHA	W	14,000(6,200~15,300)	16,000(6,200~18,000)
	PUHZ-RP6VHA <sub>1</sub>	W	14,000(5,500~15,300)	16,000(5,000~18,000)
Total input		kW	4.96	4.60
<b>Service Ref.</b>			<b>PCA-RP6GA</b>	
Power supply(phase, cycle, voltage)			Single phase, 50Hz, 220-230-240V	
Input		kW	0.22	0.22
Running current		A	1.01	1.01
Starting current		A	2.20	2.20
External finish			Munsell 0.70Y 8.59/0.97	
Heat exchanger			Plate fin coil	
INDOOR UNIT	Fan	Fan(drive) x No.	Sirocco fan (direct) x 4	
		Fan motor output	0.150	
		Airflow(Low-Med2-Med1-High)	m <sup>3</sup> /min(CFM) 27-30-32-34(955-1,060-1,130-1,200)	
		External static pressure	Pa(mmAq) 0(direct blow)	
Operation control & Thermostat			Remote controller & built-in	
Noise level(Low-Med2-Med1-High)		dB	42-44-46-48	
Unit drain pipe O.D.		mm(in.)	26(1)	
Dimensions	W	mm(in.)	1,620(63-3/4)	
	D	mm(in.)	680(26-3/4)	
	H	mm(in.)	270(10-5/8)	
Weight		kg(lbs)	45(99)	
OUTDOOR UNIT	<b>Service Ref.</b>		<b>PUHZ-RP6VHA PUHZ-RP6VHA<sub>1</sub></b>	

Notes1. Rating Conditions (ISO T1)

Cooling : Indoor : D.B. 27°C(80°F), W.B. 19°C (66°F) Outdoor : D.B. 35°C(95°F), W.B. 24°C (75°F)  
 Heating : Indoor : D.B. 20°C(68°F) Outdoor : D.B. 7°C(45°F), W.B. 6°C (43°F)  
 Refrigerant piping length (one way) : 5m (16ft)

2. Guaranteed operating range

		Indoor	Outdoor
Cooling	Upper limit	D.B. 35°C, W.B. 22.5°C	D.B. 46°C
	Lower limit	D.B. 19°C, W.B. 15°C	D.B. -5°C
Heating	Upper limit	D.B. 28°C	D.B. 21°C, W.B. 15°C
	Lower limit	D.B. 17°C	D.B. -11°C, W.B. -12°C

3. Guaranteed voltage

198~264V, 50Hz

4. Above data based on indicated voltage

Indoor Unit Single phase 230V 50Hz  
 Outdoor Unit Single phase 230V 50Hz

5. Refer to the service manual of outdoor unit for the outdoor unit's specifications.

## 4-2. Heat pump type (2)

Item		Service Ref.	PCA-RP2GA	
Function			Cooling	Heating
Capacity		Btu/h	18,300	21,200
		W	5,350	6,200
Total input		kW	2.35	2.36
<b>Service Ref.</b>			<b>PCA-RP2GA</b>	
Power supply(phase, cycle, voltage)			Single phase, 50Hz, 220-230-240V	
INDOOR UNIT	Input	kW	0.09	0.09
	Running current	A	0.41	0.41
	Starting current	A	1.20	1.20
External finish			Munsell 0.70Y 8.59/0.97	
Heat exchanger			Plate fin coil	
INDOOR UNIT	Fan	Fan(drive) x No.		Sirocco fan (direct) x 2
		Fan motor output	kW	0.054
		Airflow(Low-Med2-Med1-High)	m³/min(CFM)	10-11-12-13(355-390-425-460)
		External static pressure	Pa(mmAq)	0(direct blow)
Operation control & Thermostat			Remote controller & built-in	
Noise level(Low-Med2-Med1-High)		dB	37-38-40-42	
Unit drain pipe O.D.		mm(in.)	26(1)	
INDOOR UNIT	Dimensions	W	mm(in.)	1,000(39-3/8)
		D	mm(in.)	680(26-3/4)
		H	mm(in.)	210(8-1/4)
Weight		kg(lbs)	27(60)	
OUTDOOR UNIT	<b>Service Ref.</b>		<b>PUH-P2VGAA PUH-P2VGAA.UK / PUH-P2YGAA.UK PUH-P2VGAA<sub>1</sub>.UK / PUH-P2YGAA<sub>1</sub>.UK</b>	

Item		Service Ref.	PCA-RP2.5GA	
Function			Cooling	Heating
Capacity		Btu/h	22,500	24,700
		W	6,600	7,250
Total input		kW	2.62	2.66
<b>Service Ref.</b>			<b>PCA-RP2.5GA</b>	
Power supply(phase, cycle, voltage)			Single phase, 50Hz, 220-230-240V	
INDOOR UNIT	Input	kW	0.12	0.12
	Running current	A	0.53	0.53
	Starting current	A	1.27	1.27
External finish			Munsell 0.70Y 8.59/0.97	
Heat exchanger			Plate fin coil	
INDOOR UNIT	Fan	Fan(drive) x No.		Sirocco fan (direct) x 3
		Fan motor output	kW	0.070
		Airflow(Low-Med2-Med1-High)	m³/min(CFM)	14-15-16-18(495-530-565-635)
		External static pressure	Pa(mmAq)	0(direct blow)
Operation control & Thermostat			Remote controller & built-in	
Noise level(Low-Med2-Med1-High)		dB	37-39-41-43	
Unit drain pipe O.D.		mm(in.)	26(1)	
INDOOR UNIT	Dimensions	W	mm(in.)	1,310(51-9/16)
		D	mm(in.)	680(26-3/4)
		H	mm(in.)	210(8-1/4)
Weight		kg(lbs)	34(75)	
OUTDOOR UNIT	<b>Service Ref.</b>		<b>PUH-P2.5VGAA PUH-P2.5VGAA.UK / PUH-P2.5YGAA.UK PUH-P2.5VGAA<sub>1</sub>.UK / PUH-P2.5YGAA<sub>1</sub>.UK</b>	

### Notes1. Rating Conditions (ISO T1)

Cooling : Indoor : D.B. 27°C(80°F), W.B. 19°C (66°F)      Outdoor : D.B. 35°C(95°F), W.B. 24°C (75°F)  
 Heating : Indoor : D.B. 20°C(68°F)      Outdoor : D.B. 7°C(45°F), W.B. 6°C (43°F)  
 Refrigerant piping length (one way) : 5m (16ft)

### 2. Guaranteed operating range

		Indoor	Outdoor
Cooling	Upper limit	D.B. 35°C, W.B. 22.5°C	D.B. 46°C
	Lower limit	D.B. 19°C, W.B. 15°C	D.B. -5°C
Heating	Upper limit	D.B. 28°C	D.B. 24°C, W.B. 18°C
	Lower limit	D.B. 17°C	D.B. -11°C, W.B. -12°C

### 3. Guaranteed voltage 198~264V, 50Hz

4. Above data based on indicated voltage  
 Indoor Unit Single phase 230V 50Hz  
 Outdoor Unit Single phase 230V 50Hz / 3 phase 400V 50Hz

5. Refer to the service manual of outdoor unit for the outdoor unit's specifications.



Item			Service Ref.	PCA-RP3GA		
Function				Cooling	Heating	
Capacity			Btu/h	25,400	31,200	
			W	7,450	9,150	
Total input			kW	3.37	3.48	
INDOOR UNIT	<b>Service Ref.</b>			<b>PCA-RP3GA</b>		
	Power supply(phase, cycle, voltage)			Single phase, 50Hz, 220-230-240V		
	Input			kW	0.12	0.12
	Running current			A	0.53	0.53
	Starting current			A	1.27	1.27
	External finish			Munsell 0.70Y 8.59/0.97		
	Heat exchanger			Plate fin coil		
	Fan	Fan(drive) x No.			Sirocco fan (direct) x 3	
		Fan motor output			kW	0.070
		Airflow(Low-Med2-Med1-High)			m <sup>3</sup> /min(CFM)	14-15-16-18(495-530-565-635)
		External static pressure			Pa(mmAq)	0(direct blow)
	Operation control & Thermostat			Remote controller & built-in		
	Noise level(Low-Med2-Med1-High)			dB		37-39-41-43
	Unit drain pipe O.D.			mm(in.)		26(1)
	Dimensions	W	mm(in.)		1,310(51-9/16)	
D		mm(in.)		680(26-3/4)		
H		mm(in.)		210(8-1/4)		
Weight			kg(lbs)		34(75)	
OUTDOOR UNIT	<b>Service Ref.</b>			<b>PUH-P3VGAA / PUH-P3YGAA</b> <b>PUH-P3VGAA.UK / PUH-P3YGAA.UK</b> <b>PUH-P3VGAA<sub>1</sub>.UK / PUH-P3YGAA<sub>1</sub>.UK</b>		

Item			Service Ref.	PCA-RP4GA		
Function				Cooling	Heating	
Capacity			Btu/h	32,800	36,200	
			W	9,600	10,600	
Total input			kW	3.62	3.81	
INDOOR UNIT	<b>Service Ref.</b>			<b>PCA-RP4GA</b>		
	Power supply(phase, cycle, voltage)			Single phase, 50Hz, 220-230-240V		
	Input			kW	0.15	0.15
	Running current			A	0.69	0.69
	Starting current			A	1.48	1.48
	External finish			Munsell 0.70Y 8.59/0.97		
	Heat exchanger			Plate fin coil		
	Fan	Fan(drive) x No.			Sirocco fan (direct) x 3	
		Fan motor output			kW	0.090
		Airflow(Low-Med2-Med1-High)			m <sup>3</sup> /min(CFM)	20-21-23-25(705-740-810-885)
		External static pressure			Pa(mmAq)	0(direct blow)
	Operation control & Thermostat			Remote controller & built-in		
	Noise level(Low-Med2-Med1-High)			dB		40-41-43-45
	Unit drain pipe O.D.			mm(in.)		26(1)
	Dimensions	W	mm(in.)		1,310(51-9/16)	
D		mm(in.)		680(26-3/4)		
H		mm(in.)		270(10-5/8)		
Weight			kg(lbs)		37(82)	
OUTDOOR UNIT	<b>Service Ref.</b>			<b>PUH-P4YGAA</b> <b>PUH-P4VGAA.UK / PUH-P4YGAA.UK</b> <b>PUH-P4VGAA<sub>1</sub>.UK / PUH-P4YGAA<sub>1</sub>.UK</b>		

Notes1. Rating Conditions (ISO T1)

Cooling : Indoor : D.B. 27°C(80°F), W.B. 19°C (66°F)      Outdoor : D.B. 35°C(95°F), W.B. 24°C (75°F)  
 Heating : Indoor : D.B. 20°C(68°F)      Outdoor : D.B. 7°C(45°F), W.B. 6°C (43°F)  
 Refrigerant piping length (one way) : 5m (16ft)

2. Guaranteed operating range

		Indoor	Outdoor
Cooling	Upper limit	D.B. 35°C, W.B. 22.5°C	D.B. 46°C
	Lower limit	D.B. 19°C, W.B. 15°C	D.B. -5°C
Heating	Upper limit	D.B. 28°C	D.B. 24°C, W.B. 18°C
	Lower limit	D.B. 17°C	D.B. -11°C, W.B. -12°C

3. Guaranteed voltage  
198~264V, 50Hz

4. Above data based on indicated voltage  
Indoor Unit Single phase 240V 50Hz  
Outdoor Unit Single phase 230V 50Hz / 3 phase 400V 50Hz

5. Refer to the service manual of outdoor unit for the outdoor unit's specifications.



Item		Service Ref.	PCA-RP5GA		
Function			Cooling	Heating	
Capacity		Btu/h	42,000	50,500	
		W	12,300	14,800	
Total input		kW	4.91	5.11	
<b>Service Ref.</b>			<b>PCA-RP5GA</b>		
Power supply(phase, cycle, voltage)			Single phase, 50Hz, 220-230-240V		
Input		kW	0.22	0.22	
	Running current	A	1.01	1.01	
	Starting current	A	2.20	2.20	
External finish			Munsell 0.70Y 8.59/0.97		
Heat exchanger			Plate fin coil		
INDOOR UNIT	Fan	Fan(drive) x No.		Sirocco fan (direct) x 4	
		Fan motor output		0.150	
		Airflow(Low-Med2-Med1-High)		m <sup>3</sup> /min(CFM)	27-30-32-34(955-1,060-1,130-1,200)
		External static pressure		Pa(mmAq)	0(direct blow)
Operation control & Thermostat			Remote controller & built-in		
Noise level(Low-Med2-Med1-High)		dB	41-43-45-46		
Unit drain pipe O.D.		mm(in.)	26(1)		
Dimensions	W	mm(in.)	1,620(63-3/4)		
	D	mm(in.)	680(26-3/4)		
	H	mm(in.)	270(10-5/8)		
Weight		kg(lbs)	43(95)		
OUTDOOR UNIT	<b>Service Ref.</b>		<b>PUH-P5YGAA PUH-P5YGAA.UK PUH-P5YGAA1.UK</b>		

Item		Service Ref.	PCA-RP6GA		
Function			Cooling	Heating	
Capacity		Btu/h	48,500	58,000	
		W	14,200	17,000	
Total input		kW	5.89	6.24	
<b>Service Ref.</b>			<b>PCA-RP6GA</b>		
Power supply(phase, cycle, voltage)			Single phase, 50Hz, 220-230-240V		
Input		kW	0.22	0.22	
	Running current	A	1.01	1.01	
	Starting current	A	2.20	2.20	
External finish			Munsell 0.70Y 8.59/0.97		
Heat exchanger			Plate fin coil		
INDOOR UNIT	Fan	Fan(drive) x No.		Sirocco fan (direct) x 4	
		Fan motor output		0.150	
		Airflow(Low-Med2-Med1-High)		m <sup>3</sup> /min(CFM)	27-30-32-34(955-1,060-1,130-1,200)
		External static pressure		Pa(mmAq)	0(direct blow)
Operation control & Thermostat			Remote controller & built-in		
Noise level(Low-Med2-Med1-High)		dB	42-44-46-48		
Unit drain pipe O.D.		mm(in.)	26(1)		
Dimensions	W	mm(in.)	1,620(63-3/4)		
	D	mm(in.)	680(26-3/4)		
	H	mm(in.)	270(10-5/8)		
Weight		kg(lbs)	45(99)		
OUTDOOR UNIT	<b>Service Ref.</b>		<b>PUH-P6YGAA PUH-P6YGAA.UK PUH-P6YGAA1.UK</b>		

Notes1. Rating Conditions (ISO T1)

Cooling : Indoor : D.B. 27°C(80°F), W.B. 19°C (66°F)      Outdoor : D.B. 35°C(95°F), W.B. 24°C (75°F)  
 Heating : Indoor : D.B. 20°C(68°F)      Outdoor : D.B. 7°C(45°F), W.B. 6°C (43°F)  
 Refrigerant piping length (one way) : 5m (16ft)

2. Guaranteed operating range

		Indoor	Outdoor
Cooling	Upper limit	D.B. 35°C, W.B. 22.5°C	D.B. 46°C
	Lower limit	D.B. 19°C, W.B. 15°C	D.B. -5°C
Heating	Upper limit	D.B. 28°C	D.B. 24°C, W.B. 18°C
	Lower limit	D.B. 17°C	D.B. -11°C, W.B. -12°C

3. Guaranteed voltage

198~264V, 50Hz

4. Above data based on indicated voltage

Indoor Unit    Single phase 230V 50Hz  
 Outdoor Unit    3 phase 400V 50Hz

5. Refer to the service manual of outdoor unit for the outdoor unit's specifications.

### 4-3. Cooling type

Item		Service Ref.	PCA-RP2GA	
Function			Cooling	
Capacity		Btu/h	18,300	
		W	5,350	
Total input		kW	2.35	
INDOOR UNIT	<b>Service Ref.</b>		<b>PCA-RP2GA</b>	
	Power supply(phase, cycle, voltage)		Single phase, 50Hz, 220-230-240V	
	Input		kW	0.09
		Running current	A	0.41
		Starting current	A	1.20
	External finish			Munsell 0.70Y 8.59/0.97
	Heat exchanger			Plate fin coil
	Fan	Fan(drive) x No.		Sirocco fan (direct) x 2
		Fan motor output	kW	0.054
		Airflow(Low-Med2-Med1-High)	m³/min(CFM)	10-11-12-13(355-390-425-460)
		External static pressure	Pa(mmAq)	0(direct blow)
	Operation control & Thermostat			Remote controller & built-in
	Noise level(Low-Med2-Med1-High)		dB	37-38-40-42
	Unit drain pipe O.D.		mm(in.)	26(1)
	Dimensions	W	mm(in.)	1,000(39-3/8)
		D	mm(in.)	680(26-3/4)
H		mm(in.)	210(8-1/4)	
Weight		kg(lbs)	27(60)	
OUTDOOR UNIT	<b>Service Ref.</b>		<b>PU-P2VGAA</b> <b>PU-P2VGAA.UK / PU-P2YGAA.UK</b> <b>PU-P2VGAA<sub>1</sub>.UK / PU-P2YGAA<sub>1</sub>.UK</b>	

Item		Service Ref.	PCA-RP2.5GA	
Function			Cooling	
Capacity		Btu/h	22,500	
		W	6,600	
Total input		kW	2.62	
INDOOR UNIT	<b>Service Ref.</b>		<b>PCA-RP2.5GA</b>	
	Power supply(phase, cycle, voltage)		Single phase, 50Hz, 220-230-240V	
	Input		kW	0.12
		Running current	A	0.53
		Starting current	A	1.27
	External finish			Munsell 0.70Y 8.59/0.97
	Heat exchanger			Plate fin coil
	Fan	Fan(drive) x No.		Sirocco fan (direct) x 3
		Fan motor output	kW	0.070
		Airflow(Low-Med2-Med1-High)	m³/min(CFM)	14-15-16-18(495-530-565-635)
		External static pressure	Pa(mmAq)	0(direct blow)
	Operation control & Thermostat			Remote controller & built-in
	Noise level(Low-Med2-Med1-High)		dB	37-39-41-43
	Unit drain pipe O.D.		mm(in.)	26(1)
	Dimensions	W	mm(in.)	1,310(51-9/16)
		D	mm(in.)	680(26-3/4)
H		mm(in.)	210(8-1/4)	
Weight		kg(lbs)	34(75)	
OUTDOOR UNIT	<b>Service Ref.</b>		<b>PU-P2.5VGAA</b> <b>PU-P2.5VGAA.UK / PU-P2.5YGAA.UK</b> <b>PU-P2.5VGAA<sub>1</sub>.UK / PU-P2.5YGAA<sub>1</sub>.UK</b>	

Notes1. Rating Conditions (ISO T1)

Cooling : Indoor : D.B. 27°C(80°F), W.B. 19°C (66°F) Outdoor : D.B. 35°C(95°F), W.B. 24°C (75°F)  
Refrigerant piping length (one way) : 5m (16ft)

2. Guaranteed operating range

		Indoor	Outdoor
Cooling	Upper limit	D.B. 35°C, W.B. 22.5°C	D.B. 46°C
	Lower limit	D.B. 19°C, W.B. 15°C	D.B. -5°C

3. Guaranteed voltage

198~264V, 50Hz

4. Above data based on indicated voltage

Indoor Unit Single phase 230V 50Hz

Outdoor Unit Single phase 230V 50Hz / 3 phase 400V 50Hz

5. Refer to the service manual of outdoor unit for the outdoor unit's specifications.



Item		Service Ref.	PCA-RP3GA	
Function			Cooling	
Capacity		Btu/h	25,400	
		W	7,450	
Total input		kW	3.37	
INDOOR UNIT	<b>Service Ref.</b>		<b>PCA-RP3GA</b>	
	Power supply(phase, cycle, voltage)		Single phase, 50Hz, 220-230-240V	
	Input		kW	0.12
			A	0.53
			A	1.27
	External finish		Munsell 0.70Y 8.59/0.97	
	Heat exchanger		Plate fin coil	
	Fan	Fan(drive) x No.		Sirocco fan (direct) x 3
			kW	0.070
			m <sup>3</sup> /min(CFM)	14-15-16-18(495-530-565-635)
			Pa(mmAq)	0(direct blow)
	Operation control & Thermostat		Remote controller & built-in	
	Noise level(Low-Med2-Med1-High)		dB	37-39-41-43
	Unit drain pipe O.D.		mm(in.)	26(1)
	Dimensions	W	mm(in.)	1,310(51-9/16)
		D	mm(in.)	680(26-3/4)
H		mm(in.)	210(8-1/4)	
Weight		kg(lbs)	34(75)	
OUTDOOR UNIT	<b>Service Ref.</b>		<b>PU-P3VGAA / PU-P3YGAA</b> <b>PU-P3VGAA.UK / PU-P3YGAA.UK</b> <b>PU-P3VGAA<sub>1</sub>.UK / PU-P3YGAA<sub>1</sub>.UK</b>	

Item		Service Ref.	PCA-RP4GA	
Function			Cooling	
Capacity		Btu/h	32,800	
		W	9,600	
Total input		kW	3.62	
INDOOR UNIT	<b>Service Ref.</b>		<b>PCA-RP4GA</b>	
	Power supply(phase, cycle, voltage)		Single phase, 50Hz, 220-230-240V	
	Input		kW	0.15
			A	0.69
			A	1.48
	External finish		Munsell 0.70Y 8.59/0.97	
	Heat exchanger		Plate fin coil	
	Fan	Fan(drive) x No.		Sirocco fan (direct) x 3
			kW	0.090
			m <sup>3</sup> /min(CFM)	20-21-23-25(705-740-810-885)
			Pa(mmAq)	0(direct blow)
	Operation control & Thermostat		Remote controller & built-in	
	Noise level(Low-Med2-Med1-High)		dB	40-41-43-45
	Unit drain pipe O.D.		mm(in.)	26(1)
	Dimensions	W	mm(in.)	1,310(51-9/16)
		D	mm(in.)	680(26-3/4)
H		mm(in.)	270(10-5/8)	
Weight		kg(lbs)	37(82)	
OUTDOOR UNIT	<b>Service Ref.</b>		<b>PU-P4VGAA / PU-P4YGAA</b> <b>PU-P4VGAA.UK / PU-P4YGAA.UK</b> <b>PU-P4VGAA<sub>1</sub>.UK / PU-P4YGAA<sub>1</sub>.UK</b>	

Notes1. Rating Conditions (ISO T1)

Cooling : Indoor : D.B. 27°C(80°F), W.B. 19°C (66°F) Outdoor : D.B. 35°C(95°F), W.B. 24°C (75°F)  
Refrigerant piping length (one way) : 5m (16ft)

2. Guaranteed operating range

		Indoor	Outdoor
Cooling	Upper limit	D.B. 35°C, W.B. 22.5°C	D.B. 46°C
	Lower limit	D.B. 19°C, W.B. 15°C	D.B. -5°C

3. Guaranteed voltage  
198~264V, 50Hz

4. Above data based on indicated voltage  
Indoor Unit Single phase 230V 50Hz  
Outdoor Unit Single phase 230V 50Hz / 3 phase 400V 50Hz

5. Refer to the service manual of outdoor unit for the outdoor unit's specifications.



Item		Service Ref.	PCA-RP5GA
Function			Cooling
Capacity		Btu/h	42,000
		W	12,300
Total input		kW	4.91
<b>Service Ref.</b>			<b>PCA-RP5GA</b>
Power supply(phase, cycle, voltage)			Single phase, 50Hz, 220-230-240V
Input		kW	0.22
		A	1.01
		A	2.20
External finish			Munsell 0.70Y 8.59/0.97
Heat exchanger			Plate fin coil
INDOOR UNIT	Fan	Fan(drive) x No.	Sirocco fan (direct) x 4
		Fan motor output	0.150
		Airflow(Low-Med2-Med1-High)	m <sup>3</sup> /min(CFM) 27-30-32-34(955-1,060-1,130-1,200)
		External static pressure	Pa(mmAq) 0(direct blow)
Operation control & Thermostat			Remote controller & built-in
Noise level(Low-Med2-Med1-High)		dB	41-43-45-46
Unit drain pipe O.D.		mm(in.)	26(1)
Dimensions		W	mm(in.) 1,620(63-3/4)
		D	mm(in.) 680(26-3/4)
		H	mm(in.) 270(10/5/8)
Weight		kg(lbs)	43(95)
OUTDOOR UNIT	<b>Service Ref.</b>		<b>PU-P5YGAA PU-P5YGAA.UK PU-P5YGAA1.UK</b>

Item		Service Ref.	PCA-RP6GA
Function			Cooling
Capacity		Btu/h	48,500
		W	14,200
Total input		kW	5.89
<b>Service Ref.</b>			<b>PCA-RP6GA</b>
Power supply(phase, cycle, voltage)			Single phase, 50Hz, 220-230-240V
Input		kW	0.22
		A	1.01
		A	2.20
External finish			Munsell 0.70Y 8.59/0.97
Heat exchanger			Plate fin coil
INDOOR UNIT	Fan	Fan(drive) x No.	Sirocco fan (direct) x 4
		Fan motor output	0.150
		Airflow(Low-Med2-Med1-High)	m <sup>3</sup> /min(CFM) 27-30-32-34(955-1,060-1,130-1,200)
		External static pressure	Pa(mmAq) 0(direct blow)
Operation control & Thermostat			Remote controller & built-in
Noise level(Low-Med2-Med1-High)		dB	42-44-46-48
Unit drain pipe O.D.		mm(in.)	26(1)
Dimensions		W	mm(in.) 1,620(63-3/4)
		D	mm(in.) 680(26-3/4)
		H	mm(in.) 270(10-5/8)
Weight		kg(lbs)	45(99)
OUTDOOR UNIT	<b>Service Ref.</b>		<b>PU-P6YGAA PU-P6YGAA.UK PU-P6YGAA1.UK</b>

Notes1. Rating Conditions (ISO T1)

Cooling : Indoor : D.B. 27°C(80°F), W.B. 19°C (66°F) Outdoor : D.B. 35°C(95°F), W.B. 24°C (75°F)  
Refrigerant piping length (one way) : 5m (16ft)

2. Guaranteed operating range

		Indoor	Outdoor
Cooling	Upper limit	D.B. 35°C, W.B. 22.5°C	D.B. 46°C
	Lower limit	D.B. 19°C, W.B. 15°C	D.B. -5°C

3. Guaranteed voltage  
198~264V, 50Hz

4. Above data based on indicated voltage  
Indoor Unit Single phase 230V 50Hz  
Outdoor Unit 3 phase 400V 50Hz

5. Refer to the service manual of outdoor unit for the outdoor unit's specifications.

## 5-1. PERFORMANCE DATA (230V)

COOLING CAPACITY&lt;1&gt;

PCA-RP2GA / PUHZ-RP2VHA

(230V)

Indoor Intake air D.B.(°C)	Indoor Intake air W.B.(°C)	Outdoor intake air D.B.(°C)											
		20				25				30			
		CA	SHC(W)	SHF	P.C.	CA	SHC(W)	SHF	P.C.	CA	SHC(W)	SHF	P.C.
20	16	4653	3071	0.66	1.34	4512	2978	0.66	1.41	4371	2885	0.66	1.49
20	18	4982	2690	0.54	1.36	4841	2614	0.54	1.44	4677	2525	0.54	1.54
20	20	5358	2250	0.42	1.40	5241	2201	0.42	1.47	5100	2142	0.42	1.57
22	16	4653	3443	0.74	1.34	4512	3339	0.74	1.41	4371	3235	0.74	1.49
22	18	4982	3089	0.62	1.36	4841	3001	0.62	1.44	4677	2899	0.62	1.54
22	20	5358	2679	0.50	1.40	5241	2620	0.50	1.47	5100	2550	0.50	1.57
24	16	4653	3815	0.82	1.34	4512	3700	0.82	1.41	4371	3584	0.82	1.49
24	18	4982	3487	0.70	1.36	4841	3389	0.70	1.44	4677	3274	0.70	1.54
24	20	5358	3108	0.58	1.40	5241	3039	0.58	1.47	5100	2958	0.58	1.57
24	22	5711	2627	0.46	1.44	5593	2573	0.46	1.52	5452	2508	0.46	1.62
26	16	4653	4188	0.90	1.34	4512	4061	0.90	1.41	4371	3934	0.90	1.49
26	18	4982	3886	0.78	1.36	4841	3776	0.78	1.44	4677	3648	0.78	1.54
26	20	5358	3536	0.66	1.40	5241	3459	0.66	1.47	5100	3366	0.66	1.57
26	22	5711	3084	0.54	1.44	5593	3020	0.54	1.52	5452	2944	0.54	1.62
27	16	4653	4374	0.94	1.34	4512	4241	0.94	1.41	4371	4109	0.94	1.49
27	18	4982	4085	0.82	1.36	4841	3970	0.82	1.44	4677	3835	0.82	1.54
27	20	5358	3751	0.70	1.40	5241	3668	0.70	1.47	5100	3570	0.70	1.57
27	22	5711	3312	0.58	1.44	5593	3244	0.58	1.52	5452	3162	0.58	1.62
28	16	4653	4560	0.98	1.34	4512	4422	0.98	1.41	4371	4284	0.98	1.49
28	18	4982	4285	0.86	1.36	4841	4163	0.86	1.44	4677	4022	0.86	1.54
28	20	5358	3965	0.74	1.40	5241	3878	0.74	1.47	5100	3774	0.74	1.57
28	22	5711	3541	0.62	1.44	5593	3468	0.62	1.52	5452	3380	0.62	1.62
30	16	4653	4653	1.00	1.34	4512	4512	1.00	1.41	4371	4371	1.00	1.49
30	18	4982	4683	0.94	1.36	4841	4551	0.94	1.44	4677	4396	0.94	1.54
30	20	5358	4394	0.82	1.40	5241	4297	0.82	1.47	5100	4182	0.82	1.57
30	22	5711	3997	0.70	1.44	5593	3915	0.70	1.52	5452	3816	0.70	1.62
32	16	4653	4653	1.00	1.34	4512	4512	1.00	1.41	4371	4371	1.00	1.49
32	18	4982	4982	1.00	1.36	4841	4841	1.00	1.44	4677	4677	1.00	1.54
32	20	5358	4822	0.90	1.40	5241	4716	0.90	1.47	5100	4590	0.90	1.57
32	22	5711	4454	0.78	1.44	5593	4363	0.78	1.52	5452	4253	0.78	1.62
34	16	4653	4653	1.00	1.34	4512	4512	1.00	1.41	4371	4371	1.00	1.49
34	18	4982	4982	1.00	1.36	4841	4841	1.00	1.44	4677	4677	1.00	1.54
34	20	5358	5251	0.98	1.40	5241	5136	0.98	1.47	5100	4998	0.98	1.57
34	22	5711	4911	0.86	1.44	5593	4810	0.86	1.52	5452	4689	0.86	1.62

Notes CA : Capacity (W)  
P.C. : Power consumption (kW)

SHC(W) : Sensible heat capacity  
SHF : Sensible heat factor

**COOLING CAPACITY<2>  
PCA-RP2GA / PUHZ-RP2VHA**

**(230V)**

Indoor Intake air D.B.(°C)	Indoor Intake air W.B.(°C)	Outdoor intake air D.B.(°C)											
		35				40				45			
		CA	SHC(W)	SHF	P.C.	CA	SHC(W)	SHF	P.C.	CA	SHC(W)	SHF	P.C.
20	16	4183	2761	0.66	1.60	3995	2637	0.66	1.72	3807	2513	0.66	1.86
20	18	4512	2436	0.54	1.64	4371	2360	0.54	1.77	4089	2208	0.54	1.90
20	20	4888	2053	0.42	1.69	4700	1974	0.42	1.80	4418	1856	0.42	1.94
22	16	4183	3095	0.74	1.60	3995	2956	0.74	1.72	3807	2817	0.74	1.86
22	18	4512	2797	0.62	1.64	4371	2710	0.62	1.77	4089	2535	0.62	1.90
22	20	4888	2444	0.50	1.69	4700	2350	0.50	1.80	4418	2209	0.50	1.94
24	16	4183	3430	0.82	1.60	3995	3276	0.82	1.72	3807	3122	0.82	1.86
24	18	4512	3158	0.70	1.64	4371	3060	0.70	1.77	4089	2862	0.70	1.90
24	20	4888	2835	0.58	1.69	4700	2726	0.58	1.80	4418	2562	0.58	1.94
24	22	5264	2421	0.46	1.72	5076	2335	0.46	1.85	4794	2205	0.46	1.97
26	16	4183	3765	0.90	1.60	3995	3596	0.90	1.72	3807	3426	0.90	1.86
26	18	4512	3519	0.78	1.64	4371	3409	0.78	1.77	4089	3189	0.78	1.90
26	20	4888	3226	0.66	1.69	4700	3102	0.66	1.80	4418	2916	0.66	1.94
26	22	5264	2843	0.54	1.72	5076	2741	0.54	1.85	4794	2589	0.54	1.97
27	16	4183	3932	0.94	1.60	3995	3755	0.94	1.72	3807	3579	0.94	1.86
27	18	4512	3700	0.82	1.64	4371	3584	0.82	1.77	4089	3353	0.82	1.90
27	20	4888	3422	0.70	1.69	4700	3290	0.70	1.80	4418	3093	0.70	1.94
27	22	5264	3053	0.58	1.72	5076	2944	0.58	1.85	4794	2781	0.58	1.97
28	16	4183	4099	0.98	1.60	3995	3915	0.98	1.72	3807	3731	0.98	1.86
28	18	4512	3880	0.86	1.64	4371	3759	0.86	1.77	4089	3517	0.86	1.90
28	20	4888	3617	0.74	1.69	4700	3478	0.74	1.80	4418	3269	0.74	1.94
28	22	5264	3264	0.62	1.72	5076	3147	0.62	1.85	4794	2972	0.62	1.97
30	16	4183	4183	1.00	1.60	3995	3995	1.00	1.72	3807	3807	1.00	1.86
30	18	4512	4241	0.94	1.64	4371	4109	0.94	1.77	4089	3844	0.94	1.90
30	20	4888	4008	0.82	1.69	4700	3854	0.82	1.80	4418	3623	0.82	1.94
30	22	5264	3685	0.70	1.72	5076	3553	0.70	1.85	4794	3356	0.70	1.97
32	16	4183	4183	1.00	1.60	3995	3995	1.00	1.72	3807	3807	1.00	1.86
32	18	4512	4512	1.00	1.64	4371	4371	1.00	1.77	4089	4089	1.00	1.90
32	20	4888	4399	0.90	1.69	4700	4230	0.90	1.80	4418	3976	0.90	1.94
32	22	5264	4106	0.78	1.72	5076	3959	0.78	1.85	4794	3739	0.78	1.97
34	16	4183	4183	1.00	1.60	3995	3995	1.00	1.72	3807	3807	1.00	1.86
34	18	4512	4512	1.00	1.64	4371	4371	1.00	1.77	4089	4089	1.00	1.90
34	20	4888	4790	0.98	1.69	4700	4606	0.98	1.80	4418	4330	0.98	1.94
34	22	5264	4527	0.86	1.72	5076	4365	0.86	1.85	4794	4123	0.86	1.97

Notes CA : Capacity (W)  
P.C. : Power consumption (kW)

SHC(W) : Sensible heat capacity  
SHF : Sensible heat factor

**COOLING CAPACITY<3>**  
**PCA-RP2.5GA / PUHZ-RP2.5VHA**

**(230V)**

Indoor Intake air D.B.(°C)	Indoor Intake air W.B.(°C)	Outdoor intake air D.B.(°C)											
		20				25				30			
		CA	SHC(W)	SHF	P.C.	CA	SHC(W)	SHF	P.C.	CA	SHC(W)	SHF	P.C.
20	16	5940	4217	0.71	1.30	5760	4090	0.71	1.38	5580	3962	0.71	1.46
20	18	6360	3752	0.59	1.33	6180	3646	0.59	1.40	5970	3522	0.59	1.50
20	20	6840	3215	0.47	1.37	6690	3144	0.47	1.43	6510	3060	0.47	1.53
22	16	5940	4693	0.79	1.30	5760	4550	0.79	1.38	5580	4408	0.79	1.46
22	18	6360	4261	0.67	1.33	6180	4141	0.67	1.40	5970	4000	0.67	1.50
22	20	6840	3762	0.55	1.37	6690	3680	0.55	1.43	6510	3581	0.55	1.53
24	16	5940	5168	0.87	1.30	5760	5011	0.87	1.38	5580	4855	0.87	1.46
24	18	6360	4770	0.75	1.33	6180	4635	0.75	1.40	5970	4478	0.75	1.50
24	20	6840	4309	0.63	1.37	6690	4215	0.63	1.43	6510	4101	0.63	1.53
24	22	7290	3718	0.51	1.40	7140	3641	0.51	1.48	6960	3550	0.51	1.58
26	16	5940	5643	0.95	1.30	5760	5472	0.95	1.38	5580	5301	0.95	1.46
26	18	6360	5279	0.83	1.33	6180	5129	0.83	1.40	5970	4955	0.83	1.50
26	20	6840	4856	0.71	1.37	6690	4750	0.71	1.43	6510	4622	0.71	1.53
26	22	7290	4301	0.59	1.40	7140	4213	0.59	1.48	6960	4106	0.59	1.58
27	16	5940	5881	0.99	1.30	5760	5702	0.99	1.38	5580	5524	0.99	1.46
27	18	6360	5533	0.87	1.33	6180	5377	0.87	1.40	5970	5194	0.87	1.50
27	20	6840	5130	0.75	1.37	6690	5018	0.75	1.43	6510	4883	0.75	1.53
27	22	7290	4593	0.63	1.40	7140	4498	0.63	1.48	6960	4385	0.63	1.58
28	16	5940	5940	1.00	1.30	5760	5760	1.00	1.38	5580	5580	1.00	1.46
28	18	6360	5788	0.91	1.33	6180	5624	0.91	1.40	5970	5433	0.91	1.50
28	20	6840	5404	0.79	1.37	6690	5285	0.79	1.43	6510	5143	0.79	1.53
28	22	7290	4884	0.67	1.40	7140	4784	0.67	1.48	6960	4663	0.67	1.58
30	16	5940	5940	1.00	1.30	5760	5760	1.00	1.38	5580	5580	1.00	1.46
30	18	6360	6296	0.99	1.33	6180	6118	0.99	1.40	5970	5910	0.99	1.50
30	20	6840	5951	0.87	1.37	6690	5820	0.87	1.43	6510	5664	0.87	1.53
30	22	7290	5468	0.75	1.40	7140	5355	0.75	1.48	6960	5220	0.75	1.58
32	16	5940	5940	1.00	1.30	5760	5760	1.00	1.38	5580	5580	1.00	1.46
32	18	6360	6360	1.00	1.33	6180	6180	1.00	1.40	5970	5970	1.00	1.50
32	20	6840	6498	0.95	1.37	6690	6356	0.95	1.43	6510	6185	0.95	1.53
32	22	7290	6051	0.83	1.40	7140	5926	0.83	1.48	6960	5777	0.83	1.58
34	16	5940	5940	1.00	1.30	5760	5760	1.00	1.38	5580	5580	1.00	1.46
34	18	6360	6360	1.00	1.33	6180	6180	1.00	1.40	5970	5970	1.00	1.50
34	20	6840	6840	1.00	1.37	6690	6690	1.00	1.43	6510	6510	1.00	1.53
34	22	7290	6634	0.91	1.40	7140	6497	0.91	1.48	6960	6334	0.91	1.58

Notes CA : Capacity (W)  
P.C. : Power consumption (kW)

SHC(W) : Sensible heat capacity  
SHF : Sensible heat factor

**COOLING CAPACITY<4>  
PCA-RP2.5GA / PUHZ-RP2.5VHA**

**(230V)**

Indoor Intake air D.B.(°C)	Indoor Intake air W.B.(°C)	Outdoor intake air D.B.(°C)											
		35				40				45			
		CA	SHC(W)	SHF	P.C.	CA	SHC(W)	SHF	P.C.	CA	SHC(W)	SHF	P.C.
20	16	5340	3791	0.71	1.56	5100	3621	0.71	1.68	4860	3451	0.71	1.82
20	18	5760	3398	0.59	1.61	5580	3292	0.59	1.73	5220	3080	0.59	1.86
20	20	6240	2933	0.47	1.65	6000	2820	0.47	1.76	5640	2651	0.47	1.89
22	16	5340	4219	0.79	1.56	5100	4029	0.79	1.68	4860	3839	0.79	1.82
22	18	5760	3859	0.67	1.61	5580	3739	0.67	1.73	5220	3497	0.67	1.86
22	20	6240	3432	0.55	1.65	6000	3300	0.55	1.76	5640	3102	0.55	1.89
24	16	5340	4646	0.87	1.56	5100	4437	0.87	1.68	4860	4228	0.87	1.82
24	18	5760	4320	0.75	1.61	5580	4185	0.75	1.73	5220	3915	0.75	1.86
24	20	6240	3931	0.63	1.65	6000	3780	0.63	1.76	5640	3553	0.63	1.89
24	22	6720	3427	0.51	1.68	6480	3305	0.51	1.81	6120	3121	0.51	1.92
26	16	5340	5073	0.95	1.56	5100	4845	0.95	1.68	4860	4617	0.95	1.82
26	18	5760	4781	0.83	1.61	5580	4631	0.83	1.73	5220	4333	0.83	1.86
26	20	6240	4430	0.71	1.65	6000	4260	0.71	1.76	5640	4004	0.71	1.89
26	22	6720	3965	0.59	1.68	6480	3823	0.59	1.81	6120	3611	0.59	1.92
27	16	5340	5287	0.99	1.56	5100	5049	0.99	1.68	4860	4811	0.99	1.82
27	18	5760	5011	0.87	1.61	5580	4855	0.87	1.73	5220	4541	0.87	1.86
27	20	6240	4680	0.75	1.65	6000	4500	0.75	1.76	5640	4230	0.75	1.89
27	22	6720	4234	0.63	1.68	6480	4082	0.63	1.81	6120	3856	0.63	1.92
28	16	5340	5340	1.00	1.56	5100	5100	1.00	1.68	4860	4860	1.00	1.82
28	18	5760	5242	0.91	1.61	5580	5078	0.91	1.73	5220	4750	0.91	1.86
28	20	6240	4930	0.79	1.65	6000	4740	0.79	1.76	5640	4456	0.79	1.89
28	22	6720	4502	0.67	1.68	6480	4342	0.67	1.81	6120	4100	0.67	1.92
30	16	5340	5340	1.00	1.56	5100	5100	1.00	1.68	4860	4860	1.00	1.82
30	18	5760	5702	0.99	1.61	5580	5524	0.99	1.73	5220	5168	0.99	1.86
30	20	6240	5429	0.87	1.65	6000	5220	0.87	1.76	5640	4907	0.87	1.89
30	22	6720	5040	0.75	1.68	6480	4860	0.75	1.81	6120	4590	0.75	1.92
32	16	5340	5340	1.00	1.56	5100	5100	1.00	1.68	4860	4860	1.00	1.82
32	18	5760	5760	1.00	1.61	5580	5580	1.00	1.73	5220	5220	1.00	1.86
32	20	6240	5928	0.95	1.65	6000	5700	0.95	1.76	5640	5358	0.95	1.89
32	22	6720	5578	0.83	1.68	6480	5378	0.83	1.81	6120	5080	0.83	1.92
34	16	5340	5340	1.00	1.56	5100	5100	1.00	1.68	4860	4860	1.00	1.82
34	18	5760	5760	1.00	1.61	5580	5580	1.00	1.73	5220	5220	1.00	1.86
34	20	6240	6240	1.00	1.65	6000	6000	1.00	1.76	5640	5640	1.00	1.89
34	22	6720	6115	0.91	1.68	6480	5897	0.91	1.81	6120	5569	0.91	1.92

Notes CA : Capacity (W)  
P.C. : Power consumption (kW)

SHC(W) : Sensible heat capacity  
SHF : Sensible heat factor

**COOLING CAPACITY<5>  
PCA-RP3GA / PUHZ-RP3VHA**

**(230V)**

Indoor Intake air D.B.(°C)	Indoor Intake air W.B.(°C)	Outdoor intake air D.B.(°C)											
		20				25				30			
		CA	SHC(W)	SHF	P.C.	CA	SHC(W)	SHF	P.C.	CA	SHC(W)	SHF	P.C.
20	16	7029	4499	0.64	1.71	6816	4362	0.64	1.81	6603	4226	0.64	1.92
20	18	7526	3914	0.52	1.74	7313	3803	0.52	1.84	7065	3674	0.52	1.97
20	20	8094	3238	0.40	1.80	7917	3167	0.40	1.88	7704	3081	0.40	2.01
22	16	7029	5061	0.72	1.71	6816	4908	0.72	1.81	6603	4754	0.72	1.92
22	18	7526	4516	0.60	1.74	7313	4388	0.60	1.84	7065	4239	0.60	1.97
22	20	8094	3885	0.48	1.80	7917	3800	0.48	1.88	7704	3698	0.48	2.01
24	16	7029	5623	0.80	1.71	6816	5453	0.80	1.81	6603	5282	0.80	1.92
24	18	7526	5118	0.68	1.74	7313	4973	0.68	1.84	7065	4804	0.68	1.97
24	20	8094	4533	0.56	1.80	7917	4433	0.56	1.88	7704	4314	0.56	2.01
24	22	8627	3796	0.44	1.84	8449	3718	0.44	1.95	8236	3624	0.44	2.08
26	16	7029	6186	0.88	1.71	6816	5998	0.88	1.81	6603	5811	0.88	1.92
26	18	7526	5720	0.76	1.74	7313	5558	0.76	1.84	7065	5369	0.76	1.97
26	20	8094	5180	0.64	1.80	7917	5067	0.64	1.88	7704	4930	0.64	2.01
26	22	8627	4486	0.52	1.84	8449	4393	0.52	1.95	8236	4283	0.52	2.08
27	16	7029	6467	0.92	1.71	6816	6271	0.92	1.81	6603	6075	0.92	1.92
27	18	7526	6021	0.80	1.74	7313	5850	0.80	1.84	7065	5652	0.80	1.97
27	20	8094	5504	0.68	1.80	7917	5383	0.68	1.88	7704	5238	0.68	2.01
27	22	8627	4831	0.56	1.84	8449	4731	0.56	1.95	8236	4612	0.56	2.08
28	16	7029	6748	0.96	1.71	6816	6543	0.96	1.81	6603	6339	0.96	1.92
28	18	7526	6322	0.84	1.74	7313	6143	0.84	1.84	7065	5934	0.84	1.97
28	20	8094	5828	0.72	1.80	7917	5700	0.72	1.88	7704	5547	0.72	2.01
28	22	8627	5176	0.60	1.84	8449	5069	0.60	1.95	8236	4942	0.60	2.08
30	16	7029	7029	1.00	1.71	6816	6816	1.00	1.81	6603	6603	1.00	1.92
30	18	7526	6924	0.92	1.74	7313	6728	0.92	1.84	7065	6499	0.92	1.97
30	20	8094	6475	0.80	1.80	7917	6333	0.80	1.88	7704	6163	0.80	2.01
30	22	8627	5866	0.68	1.84	8449	5745	0.68	1.95	8236	5600	0.68	2.08
32	16	7029	7029	1.00	1.71	6816	6816	1.00	1.81	6603	6603	1.00	1.92
32	18	7526	7526	1.00	1.74	7313	7313	1.00	1.84	7065	7065	1.00	1.97
32	20	8094	7123	0.88	1.80	7917	6967	0.88	1.88	7704	6779	0.88	2.01
32	22	8627	6556	0.76	1.84	8449	6421	0.76	1.95	8236	6259	0.76	2.08
34	16	7029	7029	1.00	1.71	6816	6816	1.00	1.81	6603	6603	1.00	1.92
34	18	7526	7526	1.00	1.74	7313	7313	1.00	1.84	7065	7065	1.00	1.97
34	20	8094	7770	0.96	1.80	7917	7600	0.96	1.88	7704	7395	0.96	2.01
34	22	8627	7246	0.84	1.84	8449	7097	0.84	1.95	8236	6918	0.84	2.08

Notes CA : Capacity (W)  
P.C. : Power consumption (kW)

SHC(W) : Sensible heat capacity  
SHF : Sensible heat factor

**COOLING CAPACITY<6>  
PCA-RP3GA / PUHZ-RP3VHA**

**(230V)**

Indoor Intake air D.B.(°C)	Indoor Intake air W.B.(°C)	Outdoor intake air D.B.(°C)											
		35				40				45			
		CA	SHC(W)	SHF	P.C.	CA	SHC(W)	SHF	P.C.	CA	SHC(W)	SHF	P.C.
20	16	6319	4044	0.64	2.05	6035	3862	0.64	2.20	5751	3681	0.64	2.39
20	18	6816	3544	0.52	2.11	6603	3434	0.52	2.27	6177	3212	0.52	2.44
20	20	7384	2954	0.40	2.16	7100	2840	0.40	2.31	6674	2670	0.40	2.48
22	16	6319	4550	0.72	2.05	6035	4345	0.72	2.20	5751	4141	0.72	2.39
22	18	6816	4090	0.60	2.11	6603	3962	0.60	2.27	6177	3706	0.60	2.44
22	20	7384	3544	0.48	2.16	7100	3408	0.48	2.31	6674	3204	0.48	2.48
24	16	6319	5055	0.80	2.05	6035	4828	0.80	2.20	5751	4601	0.80	2.39
24	18	6816	4635	0.68	2.11	6603	4490	0.68	2.27	6177	4200	0.68	2.44
24	20	7384	4135	0.56	2.16	7100	3976	0.56	2.31	6674	3737	0.56	2.48
24	22	7952	3499	0.44	2.20	7668	3374	0.44	2.38	7242	3186	0.44	2.53
26	16	6319	5561	0.88	2.05	6035	5311	0.88	2.20	5751	5061	0.88	2.39
26	18	6816	5180	0.76	2.11	6603	5018	0.76	2.27	6177	4695	0.76	2.44
26	20	7384	4726	0.64	2.16	7100	4544	0.64	2.31	6674	4271	0.64	2.48
26	22	7952	4135	0.52	2.20	7668	3987	0.52	2.38	7242	3766	0.52	2.53
27	16	6319	5813	0.92	2.05	6035	5552	0.92	2.20	5751	5291	0.92	2.39
27	18	6816	5453	0.80	2.11	6603	5282	0.80	2.27	6177	4942	0.80	2.44
27	20	7384	5021	0.68	2.16	7100	4828	0.68	2.31	6674	4538	0.68	2.48
27	22	7952	4453	0.56	2.20	7668	4294	0.56	2.38	7242	4056	0.56	2.53
28	16	6319	6066	0.96	2.05	6035	5794	0.96	2.20	5751	5521	0.96	2.39
28	18	6816	5725	0.84	2.11	6603	5547	0.84	2.27	6177	5189	0.84	2.44
28	20	7384	5316	0.72	2.16	7100	5112	0.72	2.31	6674	4805	0.72	2.48
28	22	7952	4771	0.60	2.20	7668	4601	0.60	2.38	7242	4345	0.60	2.53
30	16	6319	6319	1.00	2.05	6035	6035	1.00	2.20	5751	5751	1.00	2.39
30	18	6816	6271	0.92	2.11	6603	6075	0.92	2.27	6177	5683	0.92	2.44
30	20	7384	5907	0.80	2.16	7100	5680	0.80	2.31	6674	5339	0.80	2.48
30	22	7952	5407	0.68	2.20	7668	5214	0.68	2.38	7242	4925	0.68	2.53
32	16	6319	6319	1.00	2.05	6035	6035	1.00	2.20	5751	5751	1.00	2.39
32	18	6816	6816	1.00	2.11	6603	6603	1.00	2.27	6177	6177	1.00	2.44
32	20	7384	6498	0.88	2.16	7100	6248	0.88	2.31	6674	5873	0.88	2.48
32	22	7952	6044	0.76	2.20	7668	5828	0.76	2.38	7242	5504	0.76	2.53
34	16	6319	6319	1.00	2.05	6035	6035	1.00	2.20	5751	5751	1.00	2.39
34	18	6816	6816	1.00	2.11	6603	6603	1.00	2.27	6177	6177	1.00	2.44
34	20	7384	7089	0.96	2.16	7100	6816	0.96	2.31	6674	6407	0.96	2.48
34	22	7952	6680	0.84	2.20	7668	6441	0.84	2.38	7242	6083	0.84	2.53

Notes CA : Capacity (W)  
P.C. : Power consumption (kW)

SHC(W) : Sensible heat capacity  
SHF : Sensible heat factor

**COOLING CAPACITY<7>  
PCA-RP4GA / PUAZ-RP4VHA  
PUHZ-RP4VHA<sub>1</sub>**

**(230V)**

Indoor Intake air D.B.(°C)	Indoor Intake air W.B.(°C)	Outdoor intake air D.B.(°C)											
		20				25				30			
		CA	SHC(W)	SHF	P.C.	CA	SHC(W)	SHF	P.C.	CA	SHC(W)	SHF	P.C.
20	16	9900	6435	0.65	2.34	9600	6240	0.65	2.47	9300	6045	0.65	2.61
20	18	10600	5618	0.53	2.38	10300	5459	0.53	2.51	9950	5274	0.53	2.69
20	20	11400	4674	0.41	2.45	11150	4572	0.41	2.57	10850	4449	0.41	2.74
22	16	9900	7227	0.73	2.34	9600	7008	0.73	2.47	9300	6789	0.73	2.61
22	18	10600	6466	0.61	2.38	10300	6283	0.61	2.51	9950	6070	0.61	2.69
22	20	11400	5586	0.49	2.45	11150	5464	0.49	2.57	10850	5317	0.49	2.74
24	16	9900	8019	0.81	2.34	9600	7776	0.81	2.47	9300	7533	0.81	2.61
24	18	10600	7314	0.69	2.38	10300	7107	0.69	2.51	9950	6866	0.69	2.69
24	20	11400	6498	0.57	2.45	11150	6356	0.57	2.57	10850	6185	0.57	2.74
24	22	12150	5468	0.45	2.51	11900	5355	0.45	2.66	11600	5220	0.45	2.83
26	16	9900	8811	0.89	2.34	9600	8544	0.89	2.47	9300	8277	0.89	2.61
26	18	10600	8162	0.77	2.38	10300	7931	0.77	2.51	9950	7662	0.77	2.69
26	20	11400	7410	0.65	2.45	11150	7248	0.65	2.57	10850	7053	0.65	2.74
26	22	12150	6440	0.53	2.51	11900	6307	0.53	2.66	11600	6148	0.53	2.83
27	16	9900	9207	0.93	2.34	9600	8928	0.93	2.47	9300	8649	0.93	2.61
27	18	10600	8586	0.81	2.38	10300	8343	0.81	2.51	9950	8060	0.81	2.69
27	20	11400	7866	0.69	2.45	11150	7694	0.69	2.57	10850	7487	0.69	2.74
27	22	12150	6926	0.57	2.51	11900	6783	0.57	2.66	11600	6612	0.57	2.83
28	16	9900	9603	0.97	2.34	9600	9312	0.97	2.47	9300	9021	0.97	2.61
28	18	10600	9010	0.85	2.38	10300	8755	0.85	2.51	9950	8458	0.85	2.69
28	20	11400	8322	0.73	2.45	11150	8140	0.73	2.57	10850	7921	0.73	2.74
28	22	12150	7412	0.61	2.51	11900	7259	0.61	2.66	11600	7076	0.61	2.83
30	16	9900	9900	1.00	2.34	9600	9600	1.00	2.47	9300	9300	1.00	2.61
30	18	10600	9858	0.93	2.38	10300	9579	0.93	2.51	9950	9254	0.93	2.69
30	20	11400	9234	0.81	2.45	11150	9032	0.81	2.57	10850	8789	0.81	2.74
30	22	12150	8384	0.69	2.51	11900	8211	0.69	2.66	11600	8004	0.69	2.83
32	16	9900	9900	1.00	2.34	9600	9600	1.00	2.47	9300	9300	1.00	2.61
32	18	10600	10600	1.00	2.38	10300	10300	1.00	2.51	9950	9950	1.00	2.69
32	20	11400	10146	0.89	2.45	11150	9924	0.89	2.57	10850	9657	0.89	2.74
32	22	12150	9356	0.77	2.51	11900	9163	0.77	2.66	11600	8932	0.77	2.83
34	16	9900	9900	1.00	2.34	9600	9600	1.00	2.47	9300	9300	1.00	2.61
34	18	10600	10600	1.00	2.38	10300	10300	1.00	2.51	9950	9950	1.00	2.69
34	20	11400	11058	0.97	2.45	11150	10816	0.97	2.57	10850	10525	0.97	2.74
34	22	12150	10328	0.85	2.51	11900	10115	0.85	2.66	11600	9860	0.85	2.83

Notes CA : Capacity (W)  
P.C. : Power consumption (kW)

SHC(W) : Sensible heat capacity  
SHF : Sensible heat factor



**COOLING CAPACITY<8>  
PCA-RP4GA / PUHZ-RP4VHA  
PUHZ-RP4VHA<sub>1</sub>**

**(230V)**

Indoor Intake air D.B.(°C)	Indoor Intake air W.B.(°C)	Outdoor intake air D.B.(°C)											
		35				40				45			
		CA	SHC(W)	SHF	P.C.	CA	SHC(W)	SHF	P.C.	CA	SHC(W)	SHF	P.C.
20	16	8900	5785	0.65	2.80	8500	5525	0.65	3.01	8100	5265	0.65	3.26
20	18	9600	5088	0.53	2.88	9300	4929	0.53	3.10	8700	4611	0.53	3.33
20	20	10400	4264	0.41	2.95	10000	4100	0.41	3.15	9400	3854	0.41	3.39
22	16	8900	6497	0.73	2.80	8500	6205	0.73	3.01	8100	5913	0.73	3.26
22	18	9600	5856	0.61	2.88	9300	5673	0.61	3.10	8700	5307	0.61	3.33
22	20	10400	5096	0.49	2.95	10000	4900	0.49	3.15	9400	4606	0.49	3.39
24	16	8900	7209	0.81	2.80	8500	6885	0.81	3.01	8100	6561	0.81	3.26
24	18	9600	6624	0.69	2.88	9300	6417	0.69	3.10	8700	6003	0.69	3.33
24	20	10400	5928	0.57	2.95	10000	5700	0.57	3.15	9400	5358	0.57	3.39
24	22	11200	5040	0.45	3.01	10800	4860	0.45	3.24	10200	4590	0.45	3.45
26	16	8900	7921	0.89	2.80	8500	7565	0.89	3.01	8100	7209	0.89	3.26
26	18	9600	7392	0.77	2.88	9300	7161	0.77	3.10	8700	6699	0.77	3.33
26	20	10400	6760	0.65	2.95	10000	6500	0.65	3.15	9400	6110	0.65	3.39
26	22	11200	5936	0.53	3.01	10800	5724	0.53	3.24	10200	5406	0.53	3.45
27	16	8900	8277	0.93	2.80	8500	7905	0.93	3.01	8100	7533	0.93	3.26
27	18	9600	7776	0.81	2.88	9300	7533	0.81	3.10	8700	7047	0.81	3.33
27	20	10400	7176	0.69	2.95	10000	6900	0.69	3.15	9400	6486	0.69	3.39
27	22	11200	6384	0.57	3.01	10800	6156	0.57	3.24	10200	5814	0.57	3.45
28	16	8900	8633	0.97	2.80	8500	8245	0.97	3.01	8100	7857	0.97	3.26
28	18	9600	8160	0.85	2.88	9300	7905	0.85	3.10	8700	7395	0.85	3.33
28	20	10400	7592	0.73	2.95	10000	7300	0.73	3.15	9400	6862	0.73	3.39
28	22	11200	6832	0.61	3.01	10800	6588	0.61	3.24	10200	6222	0.61	3.45
30	16	8900	8900	1.00	2.80	8500	8500	1.00	3.01	8100	8100	1.00	3.26
30	18	9600	8928	0.93	2.88	9300	8649	0.93	3.10	8700	8091	0.93	3.33
30	20	10400	8424	0.81	2.95	10000	8100	0.81	3.15	9400	7614	0.81	3.39
30	22	11200	7728	0.69	3.01	10800	7452	0.69	3.24	10200	7038	0.69	3.45
32	16	8900	8900	1.00	2.80	8500	8500	1.00	3.01	8100	8100	1.00	3.26
32	18	9600	9600	1.00	2.88	9300	9300	1.00	3.10	8700	8700	1.00	3.33
32	20	10400	9256	0.89	2.95	10000	8900	0.89	3.15	9400	8366	0.89	3.39
32	22	11200	8624	0.77	3.01	10800	8316	0.77	3.24	10200	7854	0.77	3.45
34	16	8900	8900	1.00	2.80	8500	8500	1.00	3.01	8100	8100	1.00	3.26
34	18	9600	9600	1.00	2.88	9300	9300	1.00	3.10	8700	8700	1.00	3.33
34	20	10400	10088	0.97	2.95	10000	9700	0.97	3.15	9400	9118	0.97	3.39
34	22	11200	9520	0.85	3.01	10800	9180	0.85	3.24	10200	8670	0.85	3.45

Notes CA : Capacity (W)  
P.C. : Power consumption (kW)

SHC(W) : Sensible heat capacity  
SHF : Sensible heat factor

**COOLING CAPACITY<9>**  
**PCA-RP5GA / PUHZ-RP5VHA**  
**PUHZ-RP5VHA<sub>1</sub>**

**(230V)**

Indoor Intake air D.B.(°C)	Indoor Intake air W.B.(°C)	Outdoor intake air D.B.(°C)											
		20				25				30			
		CA	SHC(W)	SHF	P.C.	CA	SHC(W)	SHF	P.C.	CA	SHC(W)	SHF	P.C.
20	16	12375	8291	0.67	3.11	12000	8040	0.67	3.29	11625	7789	0.67	3.48
20	18	13250	7288	0.55	3.17	12875	7081	0.55	3.35	12438	6841	0.55	3.58
20	20	14250	6128	0.43	3.27	13938	5993	0.43	3.42	13563	5832	0.43	3.66
22	16	12375	9281	0.75	3.11	12000	9000	0.75	3.29	11625	8719	0.75	3.48
22	18	13250	8348	0.63	3.17	12875	8111	0.63	3.35	12438	7836	0.63	3.58
22	20	14250	7268	0.51	3.27	13938	7108	0.51	3.42	13563	6917	0.51	3.66
24	16	12375	10271	0.83	3.11	12000	9960	0.83	3.29	11625	9649	0.83	3.48
24	18	13250	9408	0.71	3.17	12875	9141	0.71	3.35	12438	8831	0.71	3.58
24	20	14250	8408	0.59	3.27	13938	8223	0.59	3.42	13563	8002	0.59	3.66
24	22	15188	7138	0.47	3.35	14875	6991	0.47	3.54	14500	6815	0.47	3.77
26	16	12375	11261	0.91	3.11	12000	10920	0.91	3.29	11625	10579	0.91	3.48
26	18	13250	10468	0.79	3.17	12875	10171	0.79	3.35	12438	9826	0.79	3.58
26	20	14250	9548	0.67	3.27	13938	9338	0.67	3.42	13563	9087	0.67	3.66
26	22	15188	8353	0.55	3.35	14875	8181	0.55	3.54	14500	7975	0.55	3.77
27	16	12375	11756	0.95	3.11	12000	11400	0.95	3.29	11625	11044	0.95	3.48
27	18	13250	10998	0.83	3.17	12875	10686	0.83	3.35	12438	10323	0.83	3.58
27	20	14250	10118	0.71	3.27	13938	9896	0.71	3.42	13563	9629	0.71	3.66
27	22	15188	8961	0.59	3.35	14875	8776	0.59	3.54	14500	8555	0.59	3.77
28	16	12375	12251	0.99	3.11	12000	11880	0.99	3.29	11625	11509	0.99	3.48
28	18	13250	11528	0.87	3.17	12875	11201	0.87	3.35	12438	10821	0.87	3.58
28	20	14250	10688	0.75	3.27	13938	10453	0.75	3.42	13563	10172	0.75	3.66
28	22	15188	9568	0.63	3.35	14875	9371	0.63	3.54	14500	9135	0.63	3.77
30	16	12375	12375	1.00	3.11	12000	12000	1.00	3.29	11625	11625	1.00	3.48
30	18	13250	12588	0.95	3.17	12875	12231	0.95	3.35	12438	11816	0.95	3.58
30	20	14250	11828	0.83	3.27	13938	11568	0.83	3.42	13563	11257	0.83	3.66
30	22	15188	10783	0.71	3.35	14875	10561	0.71	3.54	14500	10295	0.71	3.77
32	16	12375	12375	1.00	3.11	12000	12000	1.00	3.29	11625	11625	1.00	3.48
32	18	13250	13250	1.00	3.17	12875	12875	1.00	3.35	12438	12438	1.00	3.58
32	20	14250	12968	0.91	3.27	13938	12683	0.91	3.42	13563	12342	0.91	3.66
32	22	15188	11998	0.79	3.35	14875	11751	0.79	3.54	14500	11455	0.79	3.77
34	16	12375	12375	1.00	3.11	12000	12000	1.00	3.29	11625	11625	1.00	3.48
34	18	13250	13250	1.00	3.17	12875	12875	1.00	3.35	12438	12438	1.00	3.58
34	20	14250	14108	0.99	3.27	13938	13798	0.99	3.42	13563	13427	0.99	3.66
34	22	15188	13213	0.87	3.35	14875	12941	0.87	3.54	14500	12615	0.87	3.77

Notes CA : Capacity (W)  
P.C. : Power consumption (kW)

SHC(W) : Sensible heat capacity  
SHF : Sensible heat factor

**COOLING CAPACITY<10>  
PCA-RP5GA / PUHZ-RP5VHA  
PUHZ-RP5VHA.**

**(230V)**

Indoor Intake air D.B.(°C)	Indoor Intake air W.B.(°C)	Outdoor intake air D.B.(°C)											
		35				40				45			
		CA	SHC(W)	SHF	P.C.	CA	SHC(W)	SHF	P.C.	CA	SHC(W)	SHF	P.C.
20	16	11125	7454	0.67	3.73	10625	7119	0.67	4.01	10125	6784	0.67	4.34
20	18	12000	6600	0.55	3.83	11625	6394	0.55	4.12	10875	5981	0.55	4.43
20	20	13000	5590	0.43	3.93	12500	5375	0.43	4.20	11750	5053	0.43	4.51
22	16	11125	8344	0.75	3.73	10625	7969	0.75	4.01	10125	7594	0.75	4.34
22	18	12000	7560	0.63	3.83	11625	7324	0.63	4.12	10875	6851	0.63	4.43
22	20	13000	6630	0.51	3.93	12500	6375	0.51	4.20	11750	5993	0.51	4.51
24	16	11125	9234	0.83	3.73	10625	8819	0.83	4.01	10125	8404	0.83	4.34
24	18	12000	8520	0.71	3.83	11625	8254	0.71	4.12	10875	7721	0.71	4.43
24	20	13000	7670	0.59	3.93	12500	7375	0.59	4.20	11750	6933	0.59	4.51
24	22	14000	6580	0.47	4.01	13500	6345	0.47	4.32	12750	5993	0.47	4.59
26	16	11125	10124	0.91	3.73	10625	9669	0.91	4.01	10125	9214	0.91	4.34
26	18	12000	9480	0.79	3.83	11625	9184	0.79	4.12	10875	8591	0.79	4.43
26	20	13000	8710	0.67	3.93	12500	8375	0.67	4.20	11750	7873	0.67	4.51
26	22	14000	7700	0.55	4.01	13500	7425	0.55	4.32	12750	7013	0.55	4.59
27	16	11125	10569	0.95	3.73	10625	10094	0.95	4.01	10125	9619	0.95	4.34
27	18	12000	9960	0.83	3.83	11625	9649	0.83	4.12	10875	9026	0.83	4.43
27	20	13000	9230	0.71	3.93	12500	8875	0.71	4.20	11750	8343	0.71	4.51
27	22	14000	8260	0.59	4.01	13500	7965	0.59	4.32	12750	7523	0.59	4.59
28	16	11125	11014	0.99	3.73	10625	10519	0.99	4.01	10125	10024	0.99	4.34
28	18	12000	10440	0.87	3.83	11625	10114	0.87	4.12	10875	9461	0.87	4.43
28	20	13000	9750	0.75	3.93	12500	9375	0.75	4.20	11750	8813	0.75	4.51
28	22	14000	8820	0.63	4.01	13500	8505	0.63	4.32	12750	8033	0.63	4.59
30	16	11125	11125	1.00	3.73	10625	10625	1.00	4.01	10125	10125	1.00	4.34
30	18	12000	11400	0.95	3.83	11625	11044	0.95	4.12	10875	10331	0.95	4.43
30	20	13000	10790	0.83	3.93	12500	10375	0.83	4.20	11750	9753	0.83	4.51
30	22	14000	9940	0.71	4.01	13500	9585	0.71	4.32	12750	9053	0.71	4.59
32	16	11125	11125	1.00	3.73	10625	10625	1.00	4.01	10125	10125	1.00	4.34
32	18	12000	12000	1.00	3.83	11625	11625	1.00	4.12	10875	10875	1.00	4.43
32	20	13000	11830	0.91	3.93	12500	11375	0.91	4.20	11750	10693	0.91	4.51
32	22	14000	11060	0.79	4.01	13500	10665	0.79	4.32	12750	10073	0.79	4.59
34	16	11125	11125	1.00	3.73	10625	10625	1.00	4.01	10125	10125	1.00	4.34
34	18	12000	12000	1.00	3.83	11625	11625	1.00	4.12	10875	10875	1.00	4.43
34	20	13000	12870	0.99	3.93	12500	12375	0.99	4.20	11750	11633	0.99	4.51
34	22	14000	12180	0.87	4.01	13500	11745	0.87	4.32	12750	11093	0.87	4.59

Notes CA : Capacity (W)  
P.C. : Power consumption (kW)

SHC(W) : Sensible heat capacity  
SHF : Sensible heat factor

**COOLING CAPACITY<11>  
PCA-RP6GA / PUHZ-RP6VHA  
PUHZ-RP6VHA<sub>1</sub>**

**(230V)**

Indoor Intake air D.B.(°C)	Indoor Intake air W.B.(°C)	Outdoor intake air D.B.(°C)											
		20				25				30			
		CA	SHC(W)	SHF	P.C.	CA	SHC(W)	SHF	P.C.	CA	SHC(W)	SHF	P.C.
20	16	13860	8870	0.64	3.97	13440	8602	0.64	4.19	13020	8333	0.64	4.44
20	18	14840	7717	0.52	4.04	14420	7498	0.52	4.27	13930	7244	0.52	4.56
20	20	15960	6384	0.40	4.17	15610	6244	0.40	4.36	15190	6076	0.40	4.66
22	16	13860	9979	0.72	3.97	13440	9677	0.72	4.19	13020	9374	0.72	4.44
22	18	14840	8904	0.60	4.04	14420	8652	0.60	4.27	13930	8358	0.60	4.56
22	20	15960	7661	0.48	4.17	15610	7493	0.48	4.36	15190	7291	0.48	4.66
24	16	13860	11088	0.80	3.97	13440	10752	0.80	4.19	13020	10416	0.80	4.44
24	18	14840	10091	0.68	4.04	14420	9806	0.68	4.27	13930	9472	0.68	4.56
24	20	15960	8938	0.56	4.17	15610	8742	0.56	4.36	15190	8506	0.56	4.66
24	22	17010	7484	0.44	4.27	16660	7330	0.44	4.51	16240	7146	0.44	4.81
26	16	13860	12197	0.88	3.97	13440	11827	0.88	4.19	13020	11458	0.88	4.44
26	18	14840	11278	0.76	4.04	14420	10959	0.76	4.27	13930	10587	0.76	4.56
26	20	15960	10214	0.64	4.17	15610	9990	0.64	4.36	15190	9722	0.64	4.66
26	22	17010	8845	0.52	4.27	16660	8663	0.52	4.51	16240	8445	0.52	4.81
27	16	13860	12751	0.92	3.97	13440	12365	0.92	4.19	13020	11978	0.92	4.44
27	18	14840	11872	0.80	4.04	14420	11536	0.80	4.27	13930	11144	0.80	4.56
27	20	15960	10853	0.68	4.17	15610	10615	0.68	4.36	15190	10329	0.68	4.66
27	22	17010	9526	0.56	4.27	16660	9330	0.56	4.51	16240	9094	0.56	4.81
28	16	13860	13306	0.96	3.97	13440	12902	0.96	4.19	13020	12499	0.96	4.44
28	18	14840	12466	0.84	4.04	14420	12113	0.84	4.27	13930	11701	0.84	4.56
28	20	15960	11491	0.72	4.17	15610	11239	0.72	4.36	15190	10937	0.72	4.66
28	22	17010	10206	0.60	4.27	16660	9996	0.60	4.51	16240	9744	0.60	4.81
30	16	13860	13860	1.00	3.97	13440	13440	1.00	4.19	13020	13020	1.00	4.44
30	18	14840	13653	0.92	4.04	14420	13266	0.92	4.27	13930	12816	0.92	4.56
30	20	15960	12768	0.80	4.17	15610	12488	0.80	4.36	15190	12152	0.80	4.66
30	22	17010	11567	0.68	4.27	16660	11329	0.68	4.51	16240	11043	0.68	4.81
32	16	13860	13860	1.00	3.97	13440	13440	1.00	4.19	13020	13020	1.00	4.44
32	18	14840	14840	1.00	4.04	14420	14420	1.00	4.27	13930	13930	1.00	4.56
32	20	15960	14045	0.88	4.17	15610	13737	0.88	4.36	15190	13367	0.88	4.66
32	22	17010	12928	0.76	4.27	16660	12662	0.76	4.51	16240	12342	0.76	4.81
34	16	13860	13860	1.00	3.97	13440	13440	1.00	4.19	13020	13020	1.00	4.44
34	18	14840	14840	1.00	4.04	14420	14420	1.00	4.27	13930	13930	1.00	4.56
34	20	15960	15322	0.96	4.17	15610	14986	0.96	4.36	15190	14582	0.96	4.66
34	22	17010	14288	0.84	4.27	16660	13994	0.84	4.51	16240	13642	0.84	4.81

Notes CA : Capacity (W)  
P.C. : Power consumption (kW)

SHC(W) : Sensible heat capacity  
SHF : Sensible heat factor

**COOLING CAPACITY<12>  
PCA-RP6GA / PUHZ-RP6VHA  
PUHZ-RP6VHA<sub>1</sub>**

**(230V)**

Indoor Intake air D.B.(°C)	Indoor Intake air W.B.(°C)	Outdoor intake air D.B.(°C)											
		35				40				45			
		CA	SHC(W)	SHF	P.C.	CA	SHC(W)	SHF	P.C.	CA	SHC(W)	SHF	P.C.
20	16	12460	7974	0.64	4.76	11900	7616	0.64	5.11	11340	7258	0.64	5.53
20	18	13440	6989	0.52	4.89	13020	6770	0.52	5.26	12180	6334	0.52	5.65
20	20	14560	5824	0.40	5.01	14000	5600	0.40	5.36	13160	5264	0.40	5.75
22	16	12460	8971	0.72	4.76	11900	8568	0.72	5.11	11340	8165	0.72	5.53
22	18	13440	8064	0.60	4.89	13020	7812	0.60	5.26	12180	7308	0.60	5.65
22	20	14560	6989	0.48	5.01	14000	6720	0.48	5.36	13160	6317	0.48	5.75
24	16	12460	9968	0.80	4.76	11900	9520	0.80	5.11	11340	9072	0.80	5.53
24	18	13440	9139	0.68	4.89	13020	8854	0.68	5.26	12180	8282	0.68	5.65
24	20	14560	8154	0.56	5.01	14000	7840	0.56	5.36	13160	7370	0.56	5.75
24	22	15680	6899	0.44	5.11	15120	6653	0.44	5.51	14280	6283	0.44	5.85
26	16	12460	10965	0.88	4.76	11900	10472	0.88	5.11	11340	9979	0.88	5.53
26	18	13440	10214	0.76	4.89	13020	9895	0.76	5.26	12180	9257	0.76	5.65
26	20	14560	9318	0.64	5.01	14000	8960	0.64	5.36	13160	8422	0.64	5.75
26	22	15680	8154	0.52	5.11	15120	7862	0.52	5.51	14280	7426	0.52	5.85
27	16	12460	11463	0.92	4.76	11900	10948	0.92	5.11	11340	10433	0.92	5.53
27	18	13440	10752	0.80	4.89	13020	10416	0.80	5.26	12180	9744	0.80	5.65
27	20	14560	9901	0.68	5.01	14000	9520	0.68	5.36	13160	8949	0.68	5.75
27	22	15680	8781	0.56	5.11	15120	8467	0.56	5.51	14280	7997	0.56	5.85
28	16	12460	11962	0.96	4.76	11900	11424	0.96	5.11	11340	10886	0.96	5.53
28	18	13440	11290	0.84	4.89	13020	10937	0.84	5.26	12180	10231	0.84	5.65
28	20	14560	10483	0.72	5.01	14000	10080	0.72	5.36	13160	9475	0.72	5.75
28	22	15680	9408	0.60	5.11	15120	9072	0.60	5.51	14280	8568	0.60	5.85
30	16	12460	12460	1.00	4.76	11900	11900	1.00	5.11	11340	11340	1.00	5.53
30	18	13440	12365	0.92	4.89	13020	11978	0.92	5.26	12180	11206	0.92	5.65
30	20	14560	11648	0.80	5.01	14000	11200	0.80	5.36	13160	10528	0.80	5.75
30	22	15680	10662	0.68	5.11	15120	10282	0.68	5.51	14280	9710	0.68	5.85
32	16	12460	12460	1.00	4.76	11900	11900	1.00	5.11	11340	11340	1.00	5.53
32	18	13440	13440	1.00	4.89	13020	13020	1.00	5.26	12180	12180	1.00	5.65
32	20	14560	12813	0.88	5.01	14000	12320	0.88	5.36	13160	11581	0.88	5.75
32	22	15680	11917	0.76	5.11	15120	11491	0.76	5.51	14280	10853	0.76	5.85
34	16	12460	12460	1.00	4.76	11900	11900	1.00	5.11	11340	11340	1.00	5.53
34	18	13440	13440	1.00	4.89	13020	13020	1.00	5.26	12180	12180	1.00	5.65
34	20	14560	13978	0.96	5.01	14000	13440	0.96	5.36	13160	12634	0.96	5.75
34	22	15680	13171	0.84	5.11	15120	12701	0.84	5.51	14280	11995	0.84	5.85

Notes CA : Capacity (W)  
P.C. : Power consumption (kW)

SHC(W) : Sensible heat capacity  
SHF : Sensible heat factor

**COOLING CAPACITY<13>**

**PCA-RP2GA / PUH-P2VGAA**

**PUH-P2VGAA.UK PUH-P2YGAA.UK**

**PUH-P2VGAA<sub>1</sub>.UK PUH-P2YGAA<sub>1</sub>.UK**

**PU-P2VGAA**

**PU-P2VGAA.UK PU-P2YGAA.UK**

**PU-P2VGAA<sub>1</sub>.UK PU-P2YGAA<sub>1</sub>.UK**

**(230V)**

Indoor Intake air D.B.(°C)	Indoor Intake air W.B.(°C)	Outdoor intake air D.B.(°C)											
		20				25				30			
		CA	SHC(W)	SHF	P.C.	CA	SHC(W)	SHF	P.C.	CA	SHC(W)	SHF	P.C.
20	16	5297	3284	0.62	1.88	5136	3184	0.62	1.99	4976	3085	0.62	2.10
20	18	5671	2836	0.50	1.92	5511	2755	0.50	2.02	5323	2662	0.50	2.16
20	20	6099	2318	0.38	1.97	5965	2267	0.38	2.07	5805	2206	0.38	2.21
22	16	5297	3708	0.70	1.88	5136	3595	0.70	1.99	4976	3483	0.70	2.10
22	18	5671	3289	0.58	1.92	5511	3196	0.58	2.02	5323	3087	0.58	2.16
22	20	6099	2806	0.46	1.97	5965	2744	0.46	2.07	5805	2670	0.46	2.21
24	16	5297	4131	0.78	1.88	5136	4006	0.78	1.99	4976	3881	0.78	2.10
24	18	5671	3743	0.66	1.92	5511	3637	0.66	2.02	5323	3513	0.66	2.16
24	20	6099	3293	0.54	1.97	5965	3221	0.54	2.07	5805	3135	0.54	2.21
24	22	6500	2730	0.42	2.02	6367	2674	0.42	2.14	6206	2607	0.42	2.28
26	16	5297	4555	0.86	1.88	5136	4417	0.86	1.99	4976	4279	0.86	2.10
26	18	5671	4197	0.74	1.92	5511	4078	0.74	2.02	5323	3939	0.74	2.16
26	20	6099	3781	0.62	1.97	5965	3698	0.62	2.07	5805	3599	0.62	2.21
26	22	6500	3250	0.50	2.02	6367	3183	0.50	2.14	6206	3103	0.50	2.28
27	16	5297	4767	0.90	1.88	5136	4622	0.90	1.99	4976	4478	0.90	2.10
27	18	5671	4423	0.78	1.92	5511	4298	0.78	2.02	5323	4152	0.78	2.16
27	20	6099	4025	0.66	1.97	5965	3937	0.66	2.07	5805	3831	0.66	2.21
27	22	6500	3510	0.54	2.02	6367	3438	0.54	2.14	6206	3351	0.54	2.28
28	16	5297	4979	0.94	1.88	5136	4828	0.94	1.99	4976	4677	0.94	2.10
28	18	5671	4650	0.82	1.92	5511	4519	0.82	2.02	5323	4365	0.82	2.16
28	20	6099	4269	0.70	1.97	5965	4176	0.70	2.07	5805	4063	0.70	2.21
28	22	6500	3770	0.58	2.02	6367	3693	0.58	2.14	6206	3599	0.58	2.28
30	16	5297	5297	1.00	1.88	5136	5136	1.00	1.99	4976	4976	1.00	2.10
30	18	5671	5104	0.90	1.92	5511	4959	0.90	2.02	5323	4791	0.90	2.16
30	20	6099	4757	0.78	1.97	5965	4653	0.78	2.07	5805	4528	0.78	2.21
30	22	6500	4290	0.66	2.02	6367	4202	0.66	2.14	6206	4096	0.66	2.28
32	16	5297	5297	1.00	1.88	5136	5136	1.00	1.99	4976	4976	1.00	2.10
32	18	5671	5558	0.98	1.92	5511	5400	0.98	2.02	5323	5217	0.98	2.16
32	20	6099	5245	0.86	1.97	5965	5130	0.86	2.07	5805	4992	0.86	2.21
32	22	6500	4810	0.74	2.02	6367	4711	0.74	2.14	6206	4592	0.74	2.28
34	16	5297	5297	1.00	1.88	5136	5136	1.00	1.99	4976	4976	1.00	2.10
34	18	5671	5671	1.00	1.92	5511	5511	1.00	2.02	5323	5323	1.00	2.16
34	20	6099	5733	0.94	1.97	5965	5607	0.94	2.07	5805	5456	0.94	2.21
34	22	6500	5330	0.82	2.02	6367	5221	0.82	2.14	6206	5089	0.82	2.28

Notes CA : Capacity (W)

P.C. : Power consumption (kW)

SHC(W) : Sensible heat capacity

SHF : Sensible heat factor

**COOLING CAPACITY<14>**

**PCA-RP2GA / PUH-P2VGAA**

**PUH-P2VGAA.UK PUH-P2YGAA.UK**

**PUH-P2VGAA<sub>1</sub>.UK PUH-P2YGAA<sub>1</sub>.UK**

**PU-P2VGAA**

**PU-P2VGAA.UK PU-P2YGAA.UK**

**PU-P2VGAA<sub>1</sub>.UK PU-P2YGAA<sub>1</sub>.UK**

**(230V)**

Indoor Intake air D.B.(°C)	Indoor Intake air W.B.(°C)	Outdoor intake air D.B.(°C)											
		35				40				45			
		CA	SHC(W)	SHF	P.C.	CA	SHC(W)	SHF	P.C.	CA	SHC(W)	SHF	P.C.
20	16	4762	2952	0.62	2.26	4548	2819	0.62	2.42	4334	2687	0.62	2.62
20	18	5136	2568	0.50	2.31	4976	2488	0.50	2.49	4655	2327	0.50	2.68
20	20	5564	2114	0.38	2.37	5350	2033	0.38	2.54	5029	1911	0.38	2.73
22	16	4762	3333	0.70	2.26	4548	3183	0.70	2.42	4334	3033	0.70	2.62
22	18	5136	2979	0.58	2.31	4976	2886	0.58	2.49	4655	2700	0.58	2.68
22	20	5564	2559	0.46	2.37	5350	2461	0.46	2.54	5029	2313	0.46	2.73
24	16	4762	3714	0.78	2.26	4548	3547	0.78	2.42	4334	3380	0.78	2.62
24	18	5136	3390	0.66	2.31	4976	3284	0.66	2.49	4655	3072	0.66	2.68
24	20	5564	3005	0.54	2.37	5350	2889	0.54	2.54	5029	2716	0.54	2.73
24	22	5992	2517	0.42	2.42	5778	2427	0.42	2.61	5457	2292	0.42	2.77
26	16	4762	4095	0.86	2.26	4548	3911	0.86	2.42	4334	3727	0.86	2.62
26	18	5136	3801	0.74	2.31	4976	3682	0.74	2.49	4655	3444	0.74	2.68
26	20	5564	3450	0.62	2.37	5350	3317	0.62	2.54	5029	3118	0.62	2.73
26	22	5992	2996	0.50	2.42	5778	2889	0.50	2.61	5457	2729	0.50	2.77
27	16	4762	4285	0.90	2.26	4548	4093	0.90	2.42	4334	3900	0.90	2.62
27	18	5136	4006	0.78	2.31	4976	3881	0.78	2.49	4655	3631	0.78	2.68
27	20	5564	3672	0.66	2.37	5350	3531	0.66	2.54	5029	3319	0.66	2.73
27	22	5992	3236	0.54	2.42	5778	3120	0.54	2.61	5457	2947	0.54	2.77
28	16	4762	4476	0.94	2.26	4548	4275	0.94	2.42	4334	4073	0.94	2.62
28	18	5136	4212	0.82	2.31	4976	4080	0.82	2.49	4655	3817	0.82	2.68
28	20	5564	3895	0.70	2.37	5350	3745	0.70	2.54	5029	3520	0.70	2.73
28	22	5992	3475	0.58	2.42	5778	3351	0.58	2.61	5457	3165	0.58	2.77
30	16	4762	4762	1.00	2.26	4548	4548	1.00	2.42	4334	4334	1.00	2.62
30	18	5136	4622	0.90	2.31	4976	4478	0.90	2.49	4655	4189	0.90	2.68
30	20	5564	4340	0.78	2.37	5350	4173	0.78	2.54	5029	3923	0.78	2.73
30	22	5992	3955	0.66	2.42	5778	3813	0.66	2.61	5457	3602	0.66	2.77
32	16	4762	4762	1.00	2.26	4548	4548	1.00	2.42	4334	4334	1.00	2.62
32	18	5136	5033	0.98	2.31	4976	4876	0.98	2.49	4655	4561	0.98	2.68
32	20	5564	4785	0.86	2.37	5350	4601	0.86	2.54	5029	4325	0.86	2.73
32	22	5992	4434	0.74	2.42	5778	4276	0.74	2.61	5457	4038	0.74	2.77
34	16	4762	4762	1.00	2.26	4548	4548	1.00	2.42	4334	4334	1.00	2.62
34	18	5136	5136	1.00	2.31	4976	4976	1.00	2.49	4655	4655	1.00	2.68
34	20	5564	5230	0.94	2.37	5350	5029	0.94	2.54	5029	4727	0.94	2.73
34	22	5992	4913	0.82	2.42	5778	4738	0.82	2.61	5457	4475	0.82	2.77

Notes CA : Capacity (W)

P.C. : Power consumption (kW)

SHC(W) : Sensible heat capacity

SHF : Sensible heat factor

**COOLING CAPACITY<15>**

**PCA-RP2.5GA / PUH-P2.5VGAA**

**PUH-P2.5VGAA.UK**

**PUH-P2.5VGAA<sub>1</sub>.UK**

**PU-P2.5VGAA**

**PU-P2.5VGAA.UK**

**PU-P2.5VGAA<sub>1</sub>.UK**

**PUH-P2.5YGAA.UK**

**PUH-P2.5YGAA<sub>1</sub>.UK**

**PU-P2.5YGAA.UK**

**PU-P2.5YGAA<sub>1</sub>.UK**

**(230V)**

Indoor Intake air D.B.(°C)	Indoor Intake air W.B.(°C)	Outdoor intake air D.B.(°C)											
		20				25				30			
		CA	SHC(W)	SHF	P.C.	CA	SHC(W)	SHF	P.C.	CA	SHC(W)	SHF	P.C.
20	16	6534	4247	0.65	2.10	6336	4118	0.65	2.21	6138	3990	0.65	2.34
20	18	6996	3708	0.53	2.14	6798	3603	0.53	2.25	6567	3481	0.53	2.41
20	20	7524	3085	0.41	2.20	7359	3017	0.41	2.31	7161	2936	0.41	2.46
22	16	6534	4770	0.73	2.10	6336	4625	0.73	2.21	6138	4481	0.73	2.34
22	18	6996	4268	0.61	2.14	6798	4147	0.61	2.25	6567	4006	0.61	2.41
22	20	7524	3687	0.49	2.20	7359	3606	0.49	2.31	7161	3509	0.49	2.46
24	16	6534	5293	0.81	2.10	6336	5132	0.81	2.21	6138	4972	0.81	2.34
24	18	6996	4827	0.69	2.14	6798	4691	0.69	2.25	6567	4531	0.69	2.41
24	20	7524	4289	0.57	2.20	7359	4195	0.57	2.31	7161	4082	0.57	2.46
24	22	8019	3609	0.45	2.25	7854	3534	0.45	2.38	7656	3445	0.45	2.54
26	16	6534	5815	0.89	2.10	6336	5639	0.89	2.21	6138	5463	0.89	2.34
26	18	6996	5387	0.77	2.14	6798	5234	0.77	2.25	6567	5057	0.77	2.41
26	20	7524	4891	0.65	2.20	7359	4783	0.65	2.31	7161	4655	0.65	2.46
26	22	8019	4250	0.53	2.25	7854	4163	0.53	2.38	7656	4058	0.53	2.54
27	16	6534	6077	0.93	2.10	6336	5892	0.93	2.21	6138	5708	0.93	2.34
27	18	6996	5667	0.81	2.14	6798	5506	0.81	2.25	6567	5319	0.81	2.41
27	20	7524	5192	0.69	2.20	7359	5078	0.69	2.31	7161	4941	0.69	2.46
27	22	8019	4571	0.57	2.25	7854	4477	0.57	2.38	7656	4364	0.57	2.54
28	16	6534	6338	0.97	2.10	6336	6146	0.97	2.21	6138	5954	0.97	2.34
28	18	6996	5947	0.85	2.14	6798	5778	0.85	2.25	6567	5582	0.85	2.41
28	20	7524	5493	0.73	2.20	7359	5372	0.73	2.31	7161	5228	0.73	2.46
28	22	8019	4892	0.61	2.25	7854	4791	0.61	2.38	7656	4670	0.61	2.54
30	16	6534	6534	1.00	2.10	6336	6336	1.00	2.21	6138	6138	1.00	2.34
30	18	6996	6506	0.93	2.14	6798	6322	0.93	2.25	6567	6107	0.93	2.41
30	20	7524	6094	0.81	2.20	7359	5961	0.81	2.31	7161	5800	0.81	2.46
30	22	8019	5533	0.69	2.25	7854	5419	0.69	2.38	7656	5283	0.69	2.54
32	16	6534	6534	1.00	2.10	6336	6336	1.00	2.21	6138	6138	1.00	2.34
32	18	6996	6996	1.00	2.14	6798	6798	1.00	2.25	6567	6567	1.00	2.41
32	20	7524	6696	0.89	2.20	7359	6550	0.89	2.31	7161	6373	0.89	2.46
32	22	8019	6175	0.77	2.25	7854	6048	0.77	2.38	7656	5895	0.77	2.54
34	16	6534	6534	1.00	2.10	6336	6336	1.00	2.21	6138	6138	1.00	2.34
34	18	6996	6996	1.00	2.14	6798	6798	1.00	2.25	6567	6567	1.00	2.41
34	20	7524	7298	0.97	2.20	7359	7138	0.97	2.31	7161	6946	0.97	2.46
34	22	8019	6816	0.85	2.25	7854	6676	0.85	2.38	7656	6508	0.85	2.54

Notes CA : Capacity (W)

P.C. : Power consumption (kW)

SHC(W) : Sensible heat capacity

SHF : Sensible heat factor



**COOLING CAPACITY<16>**

**PCA-RP2.5GA / PUH-P2.5VGAA**

**PUH-P2.5VGAA.UK      PUH-P2.5YGAA.UK**  
**PUH-P2.5VGAA<sub>1</sub>.UK    PUH-P2.5YGAA<sub>1</sub>.UK**  
**PU-P2.5VGAA**  
**PU-P2.5VGAA.UK      PU-P2.5YGAA.UK**  
**PU-P2.5VGAA<sub>1</sub>.UK    PU-P2.5YGAA<sub>1</sub>.UK**

**(230V)**

Indoor Intake air D.B.(°C)	Indoor Intake air W.B.(°C)	Outdoor intake air D.B.(°C)											
		35				40				45			
		CA	SHC(W)	SHF	P.C.	CA	SHC(W)	SHF	P.C.	CA	SHC(W)	SHF	P.C.
20	16	5874	3818	0.65	2.52	5610	3647	0.65	2.70	5346	3475	0.65	2.92
20	18	6336	3358	0.53	2.58	6138	3253	0.53	2.78	5742	3043	0.53	2.99
20	20	6864	2814	0.41	2.65	6600	2706	0.41	2.83	6204	2544	0.41	3.04
22	16	5874	4288	0.73	2.52	5610	4095	0.73	2.70	5346	3903	0.73	2.92
22	18	6336	3865	0.61	2.58	6138	3744	0.61	2.78	5742	3503	0.61	2.99
22	20	6864	3363	0.49	2.65	6600	3234	0.49	2.83	6204	3040	0.49	3.04
24	16	5874	4758	0.81	2.52	5610	4544	0.81	2.70	5346	4330	0.81	2.92
24	18	6336	4372	0.69	2.58	6138	4235	0.69	2.78	5742	3962	0.69	2.99
24	20	6864	3912	0.57	2.65	6600	3762	0.57	2.83	6204	3536	0.57	3.04
24	22	7392	3326	0.45	2.70	7128	3208	0.45	2.91	6732	3029	0.45	3.09
26	16	5874	5228	0.89	2.52	5610	4993	0.89	2.70	5346	4758	0.89	2.92
26	18	6336	4879	0.77	2.58	6138	4726	0.77	2.78	5742	4421	0.77	2.99
26	20	6864	4462	0.65	2.65	6600	4290	0.65	2.83	6204	4033	0.65	3.04
26	22	7392	3918	0.53	2.70	7128	3778	0.53	2.91	6732	3568	0.53	3.09
27	16	5874	5463	0.93	2.52	5610	5217	0.93	2.70	5346	4972	0.93	2.92
27	18	6336	5132	0.81	2.58	6138	4972	0.81	2.78	5742	4651	0.81	2.99
27	20	6864	4736	0.69	2.65	6600	4554	0.69	2.83	6204	4281	0.69	3.04
27	22	7392	4213	0.57	2.70	7128	4063	0.57	2.91	6732	3837	0.57	3.09
28	16	5874	5698	0.97	2.52	5610	5442	0.97	2.70	5346	5186	0.97	2.92
28	18	6336	5386	0.85	2.58	6138	5217	0.85	2.78	5742	4881	0.85	2.99
28	20	6864	5011	0.73	2.65	6600	4818	0.73	2.83	6204	4529	0.73	3.04
28	22	7392	4509	0.61	2.70	7128	4348	0.61	2.91	6732	4107	0.61	3.09
30	16	5874	5874	1.00	2.52	5610	5610	1.00	2.70	5346	5346	1.00	2.92
30	18	6336	5892	0.93	2.58	6138	5708	0.93	2.78	5742	5340	0.93	2.99
30	20	6864	5560	0.81	2.65	6600	5346	0.81	2.83	6204	5025	0.81	3.04
30	22	7392	5100	0.69	2.70	7128	4918	0.69	2.91	6732	4645	0.69	3.09
32	16	5874	5874	1.00	2.52	5610	5610	1.00	2.70	5346	5346	1.00	2.92
32	18	6336	6336	1.00	2.58	6138	6138	1.00	2.78	5742	5742	1.00	2.99
32	20	6864	6109	0.89	2.65	6600	5874	0.89	2.83	6204	5522	0.89	3.04
32	22	7392	5692	0.77	2.70	7128	5489	0.77	2.91	6732	5184	0.77	3.09
34	16	5874	5874	1.00	2.52	5610	5610	1.00	2.70	5346	5346	1.00	2.92
34	18	6336	6336	1.00	2.58	6138	6138	1.00	2.78	5742	5742	1.00	2.99
34	20	6864	6658	0.97	2.65	6600	6402	0.97	2.83	6204	6018	0.97	3.04
34	22	7392	6283	0.85	2.70	7128	6059	0.85	2.91	6732	5722	0.85	3.09

Notes CA : Capacity (W)

P.C. : Power consumption (kW)

SHC(W) : Sensible heat capacity

SHF : Sensible heat factor

**COOLING CAPACITY<17>**

**PCA-RP3GA / PUH-P3VGAA PUH-P3YGAA**  
**PUH-P3VGAA.UK PUH-P3YGAA.UK**  
**PUH-P3VGAA<sub>1</sub>.UK PUH-P3YGAA<sub>1</sub>.UK**  
**PU-P3VGAA PU-P3YGAA**  
**PU-P3VGAA.UK PU-P3YGAA.UK**  
**PU-P3VGAA<sub>1</sub>.UK PU-P3YGAA<sub>1</sub>.UK**

**(230V)**

Indoor Intake air D.B.(°C)	Indoor Intake air W.B.(°C)	Outdoor intake air D.B.(°C)											
		20				25				30			
		CA	SHC(W)	SHF	P.C.	CA	SHC(W)	SHF	P.C.	CA	SHC(W)	SHF	P.C.
20	16	7376	4647	0.63	2.70	7152	4506	0.63	2.85	6929	4365	0.63	3.02
20	18	7897	4027	0.51	2.75	7674	3913	0.51	2.90	7413	3781	0.51	3.10
20	20	8493	3312	0.39	2.83	8307	3240	0.39	2.97	8083	3152	0.39	3.17
22	16	7376	5237	0.71	2.70	7152	5078	0.71	2.85	6929	4919	0.71	3.02
22	18	7897	4659	0.59	2.75	7674	4527	0.59	2.90	7413	4374	0.59	3.10
22	20	8493	3992	0.47	2.83	8307	3904	0.47	2.97	8083	3799	0.47	3.17
24	16	7376	5827	0.79	2.70	7152	5650	0.79	2.85	6929	5474	0.79	3.02
24	18	7897	5291	0.67	2.75	7674	5141	0.67	2.90	7413	4967	0.67	3.10
24	20	8493	4671	0.55	2.83	8307	4569	0.55	2.97	8083	4446	0.55	3.17
24	22	9052	3892	0.43	2.90	8866	3812	0.43	3.07	8642	3716	0.43	3.27
26	16	7376	6417	0.87	2.70	7152	6222	0.87	2.85	6929	6028	0.87	3.02
26	18	7897	5923	0.75	2.75	7674	5755	0.75	2.90	7413	5560	0.75	3.10
26	20	8493	5351	0.63	2.83	8307	5233	0.63	2.97	8083	5092	0.63	3.17
26	22	9052	4616	0.51	2.90	8866	4521	0.51	3.07	8642	4407	0.51	3.27
27	16	7376	6712	0.91	2.70	7152	6508	0.91	2.85	6929	6305	0.91	3.02
27	18	7897	6239	0.79	2.75	7674	6062	0.79	2.90	7413	5856	0.79	3.10
27	20	8493	5690	0.67	2.83	8307	5566	0.67	2.97	8083	5416	0.67	3.17
27	22	9052	4978	0.55	2.90	8866	4876	0.55	3.07	8642	4753	0.55	3.27
28	16	7376	7007	0.95	2.70	7152	6794	0.95	2.85	6929	6582	0.95	3.02
28	18	7897	6555	0.83	2.75	7674	6369	0.83	2.90	7413	6153	0.83	3.10
28	20	8493	6030	0.71	2.83	8307	5898	0.71	2.97	8083	5739	0.71	3.17
28	22	9052	5341	0.59	2.90	8866	5231	0.59	3.07	8642	5099	0.59	3.27
30	16	7376	7376	1.00	2.70	7152	7152	1.00	2.85	6929	6929	1.00	3.02
30	18	7897	7186	0.91	2.75	7674	6983	0.91	2.90	7413	6746	0.91	3.10
30	20	8493	6709	0.79	2.83	8307	6562	0.79	2.97	8083	6386	0.79	3.17
30	22	9052	6065	0.67	2.90	8866	5940	0.67	3.07	8642	5790	0.67	3.27
32	16	7376	7376	1.00	2.70	7152	7152	1.00	2.85	6929	6929	1.00	3.02
32	18	7897	7818	0.99	2.75	7674	7597	0.99	2.90	7413	7339	0.99	3.10
32	20	8493	7389	0.87	2.83	8307	7227	0.87	2.97	8083	7032	0.87	3.17
32	22	9052	6789	0.75	2.90	8866	6649	0.75	3.07	8642	6482	0.75	3.27
34	16	7376	7376	1.00	2.70	7152	7152	1.00	2.85	6929	6929	1.00	3.02
34	18	7897	7897	1.00	2.75	7674	7674	1.00	2.90	7413	7413	1.00	3.10
34	20	8493	8068	0.95	2.83	8307	7891	0.95	2.97	8083	7679	0.95	3.17
34	22	9052	7513	0.83	2.90	8866	7358	0.83	3.07	8642	7173	0.83	3.27

Notes CA : Capacity (W)  
P.C. : Power consumption (kW)

SHC(W) : Sensible heat capacity  
SHF : Sensible heat factor

**COOLING CAPACITY<18>**

**PCA-RP3GA / PUH-P3VGAA PUH-P3YGAA**  
**PUH-P3VGAA.UK PUH-P3YGAA.UK**  
**PUH-P3VGAA<sub>1</sub>.UK PUH-P3YGAA<sub>1</sub>.UK**  
**PU-P3VGAA PU-P3YGAA**  
**PU-P3VGAA.UK PU-P3YGAA.UK**  
**PU-P3VGAA<sub>1</sub>.UK PU-P3YGAA<sub>1</sub>.UK**

**(230V)**

Indoor Intake air D.B.(°C)	Indoor Intake air W.B.(°C)	Outdoor intake air D.B.(°C)											
		35				40				45			
		CA	SHC(W)	SHF	P.C.	CA	SHC(W)	SHF	P.C.	CA	SHC(W)	SHF	P.C.
20	16	6631	4177	0.63	3.24	6333	3989	0.63	3.47	6035	3802	0.63	3.76
20	18	7152	3648	0.51	3.32	6929	3534	0.51	3.57	6482	3306	0.51	3.84
20	20	7748	3022	0.39	3.40	7450	2906	0.39	3.64	7003	2731	0.39	3.91
22	16	6631	4708	0.71	3.24	6333	4496	0.71	3.47	6035	4284	0.71	3.76
22	18	7152	4220	0.59	3.32	6929	4088	0.59	3.57	6482	3824	0.59	3.84
22	20	7748	3642	0.47	3.40	7450	3502	0.47	3.64	7003	3291	0.47	3.91
24	16	6631	5238	0.79	3.24	6333	5003	0.79	3.47	6035	4767	0.79	3.76
24	18	7152	4792	0.67	3.32	6929	4642	0.67	3.57	6482	4343	0.67	3.84
24	20	7748	4261	0.55	3.40	7450	4098	0.55	3.64	7003	3852	0.55	3.91
24	22	8344	3588	0.43	3.47	8046	3460	0.43	3.74	7599	3268	0.43	3.98
26	16	6631	5769	0.87	3.24	6333	5509	0.87	3.47	6035	5250	0.87	3.76
26	18	7152	5364	0.75	3.32	6929	5196	0.75	3.57	6482	4861	0.75	3.84
26	20	7748	4881	0.63	3.40	7450	4694	0.63	3.64	7003	4412	0.63	3.91
26	22	8344	4255	0.51	3.47	8046	4103	0.51	3.74	7599	3875	0.51	3.98
27	16	6631	6034	0.91	3.24	6333	5763	0.91	3.47	6035	5491	0.91	3.76
27	18	7152	5650	0.79	3.32	6929	5474	0.79	3.57	6482	5120	0.79	3.84
27	20	7748	5191	0.67	3.40	7450	4992	0.67	3.64	7003	4692	0.67	3.91
27	22	8344	4589	0.55	3.47	8046	4425	0.55	3.74	7599	4179	0.55	3.98
28	16	6631	6299	0.95	3.24	6333	6016	0.95	3.47	6035	5733	0.95	3.76
28	18	7152	5936	0.83	3.32	6929	5751	0.83	3.57	6482	5380	0.83	3.84
28	20	7748	5501	0.71	3.40	7450	5290	0.71	3.64	7003	4972	0.71	3.91
28	22	8344	4923	0.59	3.47	8046	4747	0.59	3.74	7599	4483	0.59	3.98
30	16	6631	6631	1.00	3.24	6333	6333	1.00	3.47	6035	6035	1.00	3.76
30	18	7152	6508	0.91	3.32	6929	6305	0.91	3.57	6482	5898	0.91	3.84
30	20	7748	6121	0.79	3.40	7450	5886	0.79	3.64	7003	5532	0.79	3.91
30	22	8344	5590	0.67	3.47	8046	5391	0.67	3.74	7599	5091	0.67	3.98
32	16	6631	6631	1.00	3.24	6333	6333	1.00	3.47	6035	6035	1.00	3.76
32	18	7152	7080	0.99	3.32	6929	6859	0.99	3.57	6482	6417	0.99	3.84
32	20	7748	6741	0.87	3.40	7450	6482	0.87	3.64	7003	6093	0.87	3.91
32	22	8344	6258	0.75	3.47	8046	6035	0.75	3.74	7599	5699	0.75	3.98
34	16	6631	6631	1.00	3.24	6333	6333	1.00	3.47	6035	6035	1.00	3.76
34	18	7152	7152	1.00	3.32	6929	6929	1.00	3.57	6482	6482	1.00	3.84
34	20	7748	7361	0.95	3.40	7450	7078	0.95	3.64	7003	6653	0.95	3.91
34	22	8344	6926	0.83	3.47	8046	6678	0.83	3.74	7599	6307	0.83	3.98

Notes CA : Capacity (W)

P.C. : Power consumption (kW)

SHC(W) : Sensible heat capacity

SHF : Sensible heat factor

**COOLING CAPACITY<19>**

**PCA-RP4GA /**

**PUH-P4YGAA  
PUH-P4VGAA.UK PUH-P4YGAA.UK  
PUH-P4VGAA<sub>1</sub>.UK PUH-P4YGAA<sub>1</sub>.UK  
PU-P4YGAA  
PU-P4VGAA.UK PU-P4YGAA.UK  
PU-P4VGAA<sub>1</sub>.UK PU-P4YGAA<sub>1</sub>.UK**

**(230V)**

Indoor Intake air D.B.(°C)	Indoor Intake air W.B.(°C)	Outdoor intake air D.B.(°C)											
		20				25				30			
		CA	SHC(W)	SHF	P.C.	CA	SHC(W)	SHF	P.C.	CA	SHC(W)	SHF	P.C.
20	16	9504	6273	0.66	2.90	9216	6083	0.66	3.06	8928	5892	0.66	3.24
20	18	10176	5495	0.54	2.95	9888	5340	0.54	3.11	9552	5158	0.54	3.33
20	20	10944	4596	0.42	3.04	10704	4496	0.42	3.19	10416	4375	0.42	3.40
22	16	9504	7033	0.74	2.90	9216	6820	0.74	3.06	8928	6607	0.74	3.24
22	18	10176	6309	0.62	2.95	9888	6131	0.62	3.11	9552	5922	0.62	3.33
22	20	10944	5472	0.50	3.04	10704	5352	0.50	3.19	10416	5208	0.50	3.40
24	16	9504	7793	0.82	2.90	9216	7557	0.82	3.06	8928	7321	0.82	3.24
24	18	10176	7123	0.70	2.95	9888	6922	0.70	3.11	9552	6686	0.70	3.33
24	20	10944	6348	0.58	3.04	10704	6208	0.58	3.19	10416	6041	0.58	3.40
24	22	11664	5365	0.46	3.11	11424	5255	0.46	3.29	11136	5123	0.46	3.51
26	16	9504	8554	0.90	2.90	9216	8294	0.90	3.06	8928	8035	0.90	3.24
26	18	10176	7937	0.78	2.95	9888	7713	0.78	3.11	9552	7451	0.78	3.33
26	20	10944	7223	0.66	3.04	10704	7065	0.66	3.19	10416	6875	0.66	3.40
26	22	11664	6299	0.54	3.11	11424	6169	0.54	3.29	11136	6013	0.54	3.51
27	16	9504	8934	0.94	2.90	9216	6083	0.94	3.06	8928	8392	0.94	3.24
27	18	10176	8344	0.82	2.95	9888	6083	0.82	3.11	9552	7833	0.82	3.33
27	20	10944	7661	0.70	3.04	10704	6083	0.70	3.19	10416	7291	0.70	3.40
27	22	11664	6765	0.58	3.11	11424	6083	0.58	3.29	11136	6459	0.58	3.51
28	16	9504	9314	0.98	2.90	9216	6083	0.98	3.06	8928	8749	0.98	3.24
28	18	10176	8751	0.86	2.95	9888	6083	0.86	3.11	9552	8215	0.86	3.33
28	20	10944	8099	0.74	3.04	10704	6083	0.74	3.19	10416	7708	0.74	3.40
28	22	11664	7232	0.62	3.11	11424	6083	0.62	3.29	11136	6904	0.62	3.51
30	16	9504	9504	1.00	2.90	9216	6083	1.00	3.06	8928	8928	1.00	3.24
30	18	10176	9565	0.94	2.95	9888	6083	0.94	3.11	9552	8979	0.94	3.33
30	20	10944	8974	0.82	3.04	10704	6083	0.82	3.19	10416	8541	0.82	3.40
30	22	11664	8165	0.70	3.11	11424	6083	0.70	3.29	11136	7795	0.70	3.51
32	16	9504	9504	1.00	2.90	9216	6083	1.00	3.06	8928	8928	1.00	3.24
32	18	10176	10176	1.00	2.95	9888	6083	1.00	3.11	9552	9552	1.00	3.33
32	20	10944	9850	0.90	3.04	10704	6083	0.90	3.19	10416	9374	0.90	3.40
32	22	11664	9098	0.78	3.11	11424	6083	0.78	3.29	11136	8686	0.78	3.51
34	16	9504	9504	1.00	2.90	9216	6083	1.00	3.06	8928	8928	1.00	3.24
34	18	10176	10176	1.00	2.95	9888	6083	1.00	3.11	9552	9552	1.00	3.33
34	20	10944	10725	0.98	3.04	10704	6083	0.98	3.19	10416	10208	0.98	3.40
34	22	11664	10031	0.86	3.11	11424	6083	0.86	3.29	11136	9577	0.86	3.51

Notes CA : Capacity (W)  
P.C. : Power consumption (kW)

SHC(W) : Sensible heat capacity  
SHF : Sensible heat factor

**COOLING CAPACITY<20>**

**PCA-RP4GA /**

**PUH-P4YGAA  
PUH-P4VGAA.UK PUH-P4YGAA.UK  
PUH-P4VGAA<sub>1</sub>.UK PUH-P4YGAA<sub>1</sub>.UK  
PU-P4YGAA  
PU-P4VGAA.UK PU-P4YGAA.UK  
PU-P4VGAA<sub>1</sub>.UK PU-P4YGAA<sub>1</sub>.UK**

**(230V)**

Indoor Intake air D.B.(°C)	Indoor Intake air W.B.(°C)	Outdoor intake air D.B.(°C)											
		35				40				45			
		CA	SHC(W)	SHF	P.C.	CA	SHC(W)	SHF	P.C.	CA	SHC(W)	SHF	P.C.
20	16	8544	5639	0.66	3.48	8160	5386	0.66	3.73	7776	5132	0.66	4.04
20	18	9216	4977	0.54	3.57	8928	4821	0.54	3.84	8352	4510	0.54	4.13
20	20	9984	4193	0.42	3.66	9600	4032	0.42	3.91	9024	3790	0.42	4.20
22	16	8544	6323	0.74	3.48	8160	6038	0.74	3.73	7776	5754	0.74	4.04
22	18	9216	5714	0.62	3.57	8928	5535	0.62	3.84	8352	5178	0.62	4.13
22	20	9984	4992	0.50	3.66	9600	4800	0.50	3.91	9024	4512	0.50	4.20
24	16	8544	7006	0.82	3.48	8160	6691	0.82	3.73	7776	6376	0.82	4.04
24	18	9216	6451	0.70	3.57	8928	6250	0.70	3.84	8352	5846	0.70	4.13
24	20	9984	5791	0.58	3.66	9600	5568	0.58	3.91	9024	5234	0.58	4.20
24	22	10752	4946	0.46	3.73	10368	4769	0.46	4.02	9792	4504	0.46	4.27
26	16	8544	7690	0.90	3.48	8160	7344	0.90	3.73	7776	6998	0.90	4.04
26	18	9216	7188	0.78	3.57	8928	6964	0.78	3.84	8352	6515	0.78	4.13
26	20	9984	6589	0.66	3.66	9600	6336	0.66	3.91	9024	5956	0.66	4.20
26	22	10752	5806	0.54	3.73	10368	5599	0.54	4.02	9792	5288	0.54	4.27
27	16	8544	8031	0.94	3.48	8160	7670	0.94	3.73	7776	7309	0.94	4.04
27	18	9216	7557	0.82	3.57	8928	7321	0.82	3.84	8352	6849	0.82	4.13
27	20	9984	6989	0.70	3.66	9600	6720	0.70	3.91	9024	6317	0.70	4.20
27	22	10752	6236	0.58	3.73	10368	6013	0.58	4.02	9792	5679	0.58	4.27
28	16	8544	8373	0.98	3.48	8160	7997	0.98	3.73	7776	7620	0.98	4.04
28	18	9216	7926	0.86	3.57	8928	7678	0.86	3.84	8352	7183	0.86	4.13
28	20	9984	7388	0.74	3.66	9600	7104	0.74	3.91	9024	6678	0.74	4.20
28	22	10752	6666	0.62	3.73	10368	6428	0.62	4.02	9792	6071	0.62	4.27
30	16	8544	8544	1.00	3.48	8160	8160	1.00	3.73	7776	7776	1.00	4.04
30	18	9216	8663	0.94	3.57	8928	8392	0.94	3.84	8352	7851	0.94	4.13
30	20	9984	8187	0.82	3.66	9600	7872	0.82	3.91	9024	7400	0.82	4.20
30	22	10752	7526	0.70	3.73	10368	7258	0.70	4.02	9792	6854	0.70	4.27
32	16	8544	8544	1.00	3.48	8160	8160	1.00	3.73	7776	7776	1.00	4.04
32	18	9216	9216	1.00	3.57	8928	8928	1.00	3.84	8352	8352	1.00	4.13
32	20	9984	8986	0.90	3.66	9600	8640	0.90	3.91	9024	8122	0.90	4.20
32	22	10752	8387	0.78	3.73	10368	8087	0.78	4.02	9792	7638	0.78	4.27
34	16	8544	8544	1.00	3.48	8160	8160	1.00	3.73	7776	7776	1.00	4.04
34	18	9216	9216	1.00	3.57	8928	8928	1.00	3.84	8352	8352	1.00	4.13
34	20	9984	9784	0.98	3.66	9600	9408	0.98	3.91	9024	8844	0.98	4.20
34	22	10752	9247	0.86	3.73	10368	8916	0.86	4.02	9792	8421	0.86	4.27

Notes CA : Capacity (W)

P.C. : Power consumption (kW)

SHC(W) : Sensible heat capacity

SHF : Sensible heat factor

**COOLING CAPACITY<21>**

**PCA-RP5GA / PUH-P5YGAA**

**PUH-P5YGAA.UK**

**PUH-P5YGAA.UK**

**PU-P5YGAA**

**PU-P5YGAA.UK**

**PU-P5YGAA.UK**

**(230V)**

Indoor Intake air D.B.(°C)	Indoor Intake air W.B.(°C)	Outdoor intake air D.B.(°C)											
		20				25				30			
		CA	SHC(W)	SHF	P.C.	CA	SHC(W)	SHF	P.C.	CA	SHC(W)	SHF	P.C.
20	16	12177	8159	0.67	3.93	11808	7911	0.67	4.15	11439	7664	0.67	4.39
20	18	13038	7171	0.55	4.00	12669	6968	0.55	4.22	12239	6731	0.55	4.52
20	20	14022	6029	0.43	4.12	13715	5897	0.43	4.32	13346	5739	0.43	4.62
22	16	12177	9133	0.75	3.93	11808	8856	0.75	4.15	11439	8579	0.75	4.39
22	18	13038	8214	0.63	4.00	12669	7981	0.63	4.22	12239	7710	0.63	4.52
22	20	14022	7151	0.51	4.12	13715	6994	0.51	4.32	13346	6806	0.51	4.62
24	16	12177	10107	0.83	3.93	11808	9801	0.83	4.15	11439	9494	0.83	4.39
24	18	13038	9257	0.71	4.00	12669	8995	0.71	4.22	12239	8689	0.71	4.52
24	20	14022	8273	0.59	4.12	13715	8092	0.59	4.32	13346	7874	0.59	4.62
24	22	14945	7024	0.47	4.22	14637	6879	0.47	4.47	14268	6706	0.47	4.76
26	16	12177	11081	0.91	3.93	11808	10745	0.91	4.15	11439	10409	0.91	4.39
26	18	13038	10300	0.79	4.00	12669	10009	0.79	4.22	12239	9668	0.79	4.52
26	20	14022	9395	0.67	4.12	13715	9189	0.67	4.32	13346	8941	0.67	4.62
26	22	14945	8219	0.55	4.22	14637	8050	0.55	4.47	14268	7847	0.55	4.76
27	16	12177	11568	0.95	3.93	11808	11218	0.95	4.15	11439	10867	0.95	4.39
27	18	13038	10822	0.83	4.00	12669	10515	0.83	4.22	12239	10158	0.83	4.52
27	20	14022	9956	0.71	4.12	13715	9737	0.71	4.32	13346	9475	0.71	4.62
27	22	14945	8817	0.59	4.22	14637	8636	0.59	4.47	14268	8418	0.59	4.76
28	16	12177	12055	0.99	3.93	11808	11690	0.99	4.15	11439	11325	0.99	4.39
28	18	13038	11343	0.87	4.00	12669	11022	0.87	4.22	12239	10647	0.87	4.52
28	20	14022	10517	0.75	4.12	13715	10286	0.75	4.32	13346	10009	0.75	4.62
28	22	14945	9415	0.63	4.22	14637	9221	0.63	4.47	14268	8989	0.63	4.76
30	16	12177	12177	1.00	3.93	11808	11808	1.00	4.15	11439	11439	1.00	4.39
30	18	13038	12386	0.95	4.00	12669	12036	0.95	4.22	12239	11627	0.95	4.52
30	20	14022	11638	0.83	4.12	13715	11383	0.83	4.32	13346	11077	0.83	4.62
30	22	14945	10611	0.71	4.22	14637	10392	0.71	4.47	14268	10130	0.71	4.76
32	16	12177	12177	1.00	3.93	11808	11808	1.00	4.15	11439	11439	1.00	4.39
32	18	13038	13038	1.00	4.00	12669	12669	1.00	4.22	12239	12239	1.00	4.52
32	20	14022	12760	0.91	4.12	13715	12480	0.91	4.32	13346	12144	0.91	4.62
32	22	14945	11806	0.79	4.22	14637	11563	0.79	4.47	14268	11272	0.79	4.76
34	16	12177	12177	1.00	3.93	11808	11808	1.00	4.15	11439	11439	1.00	4.39
34	18	13038	13038	1.00	4.00	12669	12669	1.00	4.22	12239	12239	1.00	4.52
34	20	14022	13882	0.99	4.12	13715	13577	0.99	4.32	13346	13212	0.99	4.62
34	22	14945	13002	0.87	4.22	14637	12734	0.87	4.47	14268	12413	0.87	4.76

Notes CA : Capacity (W)  
P.C. : Power consumption (kW)

SHC(W) : Sensible heat capacity  
SHF : Sensible heat factor

**COOLING CAPACITY<22>  
 PCA-RP5GA / PUH-P5YGAA  
 PUH-P5YGAA.UK  
 PUH-P5YGAA.UK  
 PU-P5YGAA  
 PU-P5YGAA.UK  
 PU-P5YGAA.UK**

**(230V)**

Indoor Intake air D.B.(°C)	Indoor Intake air W.B.(°C)	Outdoor intake air D.B.(°C)											
		35				40				45			
		CA	SHC(W)	SHF	P.C.	CA	SHC(W)	SHF	P.C.	CA	SHC(W)	SHF	P.C.
20	16	10947	7334	0.67	4.71	10455	7005	0.67	5.06	9963	6675	0.67	5.47
20	18	11808	6494	0.55	4.84	11439	6291	0.55	5.20	10701	5886	0.55	5.60
20	20	12792	5501	0.43	4.96	12300	5289	0.43	5.30	11562	4972	0.43	5.70
22	16	10947	8210	0.75	4.71	10455	7841	0.75	5.06	9963	7472	0.75	5.47
22	18	11808	7439	0.63	4.84	11439	7207	0.63	5.20	10701	6742	0.63	5.60
22	20	12792	6524	0.51	4.96	12300	6273	0.51	5.30	11562	5897	0.51	5.70
24	16	10947	9086	0.83	4.71	10455	8678	0.83	5.06	9963	8269	0.83	5.47
24	18	11808	8384	0.71	4.84	11439	8122	0.71	5.20	10701	7598	0.71	5.60
24	20	12792	7547	0.59	4.96	12300	7257	0.59	5.30	11562	6822	0.59	5.70
24	22	13776	6475	0.47	5.06	13284	6243	0.47	5.45	12546	5897	0.47	5.79
26	16	10947	9962	0.91	4.71	10455	9514	0.91	5.06	9963	9066	0.91	5.47
26	18	11808	9328	0.79	4.84	11439	9037	0.79	5.20	10701	8454	0.79	5.60
26	20	12792	8571	0.67	4.96	12300	8241	0.67	5.30	11562	7747	0.67	5.70
26	22	13776	7577	0.55	5.06	13284	7306	0.55	5.45	12546	6900	0.55	5.79
27	16	10947	10400	0.95	4.71	10455	9932	0.95	5.06	9963	9465	0.95	5.47
27	18	11808	9801	0.83	4.84	11439	9494	0.83	5.20	10701	8882	0.83	5.60
27	20	12792	9082	0.71	4.96	12300	8733	0.71	5.30	11562	8209	0.71	5.70
27	22	13776	8128	0.59	5.06	13284	7838	0.59	5.45	12546	7402	0.59	5.79
28	16	10947	10838	0.99	4.71	10455	10350	0.99	5.06	9963	9863	0.99	5.47
28	18	11808	10273	0.87	4.84	11439	9952	0.87	5.20	10701	9310	0.87	5.60
28	20	12792	9594	0.75	4.96	12300	9225	0.75	5.30	11562	8672	0.75	5.70
28	22	13776	8679	0.63	5.06	13284	8369	0.63	5.45	12546	7904	0.63	5.79
30	16	10947	10947	1.00	4.71	10455	10455	1.00	5.06	9963	9963	1.00	5.47
30	18	11808	11218	0.95	4.84	11439	10867	0.95	5.20	10701	10166	0.95	5.60
30	20	12792	10617	0.83	4.96	12300	10209	0.83	5.30	11562	9596	0.83	5.70
30	22	13776	9781	0.71	5.06	13284	9432	0.71	5.45	12546	8908	0.71	5.79
32	16	10947	10947	1.00	4.71	10455	10455	1.00	5.06	9963	9963	1.00	5.47
32	18	11808	11808	1.00	4.84	11439	11439	1.00	5.20	10701	10701	1.00	5.60
32	20	12792	11641	0.91	4.96	12300	11193	0.91	5.30	11562	10521	0.91	5.70
32	22	13776	10883	0.79	5.06	13284	10494	0.79	5.45	12546	9911	0.79	5.79
34	16	10947	10947	1.00	4.71	10455	10455	1.00	5.06	9963	9963	1.00	5.47
34	18	11808	11808	1.00	4.84	11439	11439	1.00	5.20	10701	10701	1.00	5.60
34	20	12792	12664	0.99	4.96	12300	12177	0.99	5.30	11562	11446	0.99	5.70
34	22	13776	11985	0.87	5.06	13284	11557	0.87	5.45	12546	10915	0.87	5.79

Notes CA : Capacity (W)

P.C. : Power consumption (kW)

SHC(W) : Sensible heat capacity

SHF : Sensible heat factor

**COOLING CAPACITY<23>**

**PCA-RP6GA / PUH-P6YGAA**

**PUH-P6YGAA.UK**

**PUH-P6YGAA.UK**

**PU-P6YGAA**

**PU-P6YGAA.UK**

**PU-P6YGAA.UK**

**(230V)**

Indoor Intake air D.B.(°C)	Indoor Intake air W.B.(°C)	Outdoor intake air D.B.(°C)											
		20				25				30			
		CA	SHC(W)	SHF	P.C.	CA	SHC(W)	SHF	P.C.	CA	SHC(W)	SHF	P.C.
20	16	14058	8997	0.64	4.71	13632	8724	0.64	4.98	13206	8452	0.64	5.27
20	18	15052	7827	0.52	4.80	14626	7606	0.52	5.07	14129	7347	0.52	5.42
20	20	16188	6475	0.40	4.95	15833	6333	0.40	5.18	15407	6163	0.40	5.54
22	16	14058	10122	0.72	4.71	13632	9815	0.72	4.98	13206	9508	0.72	5.27
22	18	15052	9031	0.60	4.80	14626	8776	0.60	5.07	14129	8477	0.60	5.42
22	20	16188	7770	0.48	4.95	15833	7600	0.48	5.18	15407	7395	0.48	5.54
24	16	14058	11246	0.80	4.71	13632	10906	0.80	4.98	13206	10565	0.80	5.27
24	18	15052	10235	0.68	4.80	14626	9946	0.68	5.07	14129	9608	0.68	5.42
24	20	16188	9065	0.56	4.95	15833	8866	0.56	5.18	15407	8628	0.56	5.54
24	22	17253	7591	0.44	5.07	16898	7435	0.44	5.36	16472	7248	0.44	5.71
26	16	14058	12371	0.88	4.71	13632	11996	0.88	4.98	13206	11621	0.88	5.27
26	18	15052	11440	0.76	4.80	14626	11116	0.76	5.07	14129	10738	0.76	5.42
26	20	16188	10360	0.64	4.95	15833	10133	0.64	5.18	15407	9860	0.64	5.54
26	22	17253	8972	0.52	5.07	16898	8787	0.52	5.36	16472	8565	0.52	5.71
27	16	14058	12933	0.92	4.71	13632	12541	0.92	4.98	13206	12150	0.92	5.27
27	18	15052	12042	0.80	4.80	14626	11701	0.80	5.07	14129	11303	0.80	5.42
27	20	16188	11008	0.68	4.95	15833	10766	0.68	5.18	15407	10477	0.68	5.54
27	22	17253	9662	0.56	5.07	16898	9463	0.56	5.36	16472	9224	0.56	5.71
28	16	14058	13496	0.96	4.71	13632	13087	0.96	4.98	13206	12678	0.96	5.27
28	18	15052	12644	0.84	4.80	14626	12286	0.84	5.07	14129	11868	0.84	5.42
28	20	16188	11655	0.72	4.95	15833	11400	0.72	5.18	15407	11093	0.72	5.54
28	22	17253	10352	0.60	5.07	16898	10139	0.60	5.36	16472	9883	0.60	5.71
30	16	14058	14058	1.00	4.71	13632	13632	1.00	4.98	13206	13206	1.00	5.27
30	18	15052	13848	0.92	4.80	14626	13456	0.92	5.07	14129	12999	0.92	5.42
30	20	16188	12950	0.80	4.95	15833	12666	0.80	5.18	15407	12326	0.80	5.54
30	22	17253	11732	0.68	5.07	16898	11491	0.68	5.36	16472	11201	0.68	5.71
32	16	14058	14058	1.00	4.71	13632	13632	1.00	4.98	13206	13206	1.00	5.27
32	18	15052	15052	1.00	4.80	14626	14626	1.00	5.07	14129	14129	1.00	5.42
32	20	16188	14245	0.88	4.95	15833	13933	0.88	5.18	15407	13558	0.88	5.54
32	22	17253	13112	0.76	5.07	16898	12842	0.76	5.36	16472	12519	0.76	5.71
34	16	14058	14058	1.00	4.71	13632	13632	1.00	4.98	13206	13206	1.00	5.27
34	18	15052	15052	1.00	4.80	14626	14626	1.00	5.07	14129	14129	1.00	5.42
34	20	16188	15540	0.96	4.95	15833	15200	0.96	5.18	15407	14791	0.96	5.54
34	22	17253	14493	0.84	5.07	16898	14194	0.84	5.36	16472	13836	0.84	5.71

Notes CA : Capacity (W)  
P.C. : Power consumption (kW)

SHC(W) : Sensible heat capacity  
SHF : Sensible heat factor



**COOLING CAPACITY<24>  
 PCA-RP6GA / PUH-P6YGAA  
 PUH-P6YGAA.UK  
 PUH-P6YGAA.UK  
 PU-P6YGAA  
 PU-P6YGAA.UK  
 PU-P6YGAA.UK**

**(230V)**

Indoor Intake air D.B.(°C)	Indoor Intake air W.B.(°C)	Outdoor intake air D.B.(°C)											
		35				40				45			
		CA	SHC(W)	SHF	P.C.	CA	SHC(W)	SHF	P.C.	CA	SHC(W)	SHF	P.C.
20	16	12638	8088	0.64	5.65	12070	7725	0.64	6.07	11502	7361	0.64	6.57
20	18	13632	7089	0.52	5.80	13206	6867	0.52	6.24	12354	6424	0.52	6.71
20	20	14768	5907	0.40	5.95	14200	5680	0.40	6.36	13348	5339	0.40	6.83
22	16	12638	9099	0.72	5.65	12070	8690	0.72	6.07	11502	8281	0.72	6.57
22	18	13632	8179	0.60	5.80	13206	7924	0.60	6.24	12354	7412	0.60	6.71
22	20	14768	7089	0.48	5.95	14200	6816	0.48	6.36	13348	6407	0.48	6.83
24	16	12638	10110	0.80	5.65	12070	9656	0.80	6.07	11502	9202	0.80	6.57
24	18	13632	9270	0.68	5.80	13206	8980	0.68	6.24	12354	8401	0.68	6.71
24	20	14768	8270	0.56	5.95	14200	7952	0.56	6.36	13348	7475	0.56	6.83
24	22	15904	6998	0.44	6.07	15336	6748	0.44	6.54	14484	6373	0.44	6.95
26	16	12638	11121	0.88	5.65	12070	10622	0.88	6.07	11502	10122	0.88	6.57
26	18	13632	10360	0.76	5.80	13206	10037	0.76	6.24	12354	9389	0.76	6.71
26	20	14768	9452	0.64	5.95	14200	9088	0.64	6.36	13348	8543	0.64	6.83
26	22	15904	8270	0.52	6.07	15336	7975	0.52	6.54	14484	7532	0.52	6.95
27	16	12638	11627	0.92	5.65	12070	11104	0.92	6.07	11502	10582	0.92	6.57
27	18	13632	10906	0.80	5.80	13206	10565	0.80	6.24	12354	9883	0.80	6.71
27	20	14768	10042	0.68	5.95	14200	9656	0.68	6.36	13348	9077	0.68	6.83
27	22	15904	8906	0.56	6.07	15336	8588	0.56	6.54	14484	8111	0.56	6.95
28	16	12638	12132	0.96	5.65	12070	11587	0.96	6.07	11502	11042	0.96	6.57
28	18	13632	11451	0.84	5.80	13206	11093	0.84	6.24	12354	10377	0.84	6.71
28	20	14768	10633	0.72	5.95	14200	10224	0.72	6.36	13348	9611	0.72	6.83
28	22	15904	9542	0.60	6.07	15336	9202	0.60	6.54	14484	8690	0.60	6.95
30	16	12638	12638	1.00	5.65	12070	12070	1.00	6.07	11502	11502	1.00	6.57
30	18	13632	12541	0.92	5.80	13206	12150	0.92	6.24	12354	11366	0.92	6.71
30	20	14768	11814	0.80	5.95	14200	11360	0.80	6.36	13348	10678	0.80	6.83
30	22	15904	10815	0.68	6.07	15336	10428	0.68	6.54	14484	9849	0.68	6.95
32	16	12638	12638	1.00	5.65	12070	12070	1.00	6.07	11502	11502	1.00	6.57
32	18	13632	13632	1.00	5.80	13206	13206	1.00	6.24	12354	12354	1.00	6.71
32	20	14768	12996	0.88	5.95	14200	12496	0.88	6.36	13348	11746	0.88	6.83
32	22	15904	12087	0.76	6.07	15336	11655	0.76	6.54	14484	11008	0.76	6.95
34	16	12638	12638	1.00	5.65	12070	12070	1.00	6.07	11502	11502	1.00	6.57
34	18	13632	13632	1.00	5.80	13206	13206	1.00	6.24	12354	12354	1.00	6.71
34	20	14768	14177	0.96	5.95	14200	13632	0.96	6.36	13348	12814	0.96	6.83
34	22	15904	13359	0.84	6.07	15336	12882	0.84	6.54	14484	12167	0.84	6.95

Notes CA : Capacity (W)  
 P.C. : Power consumption (kW)

SHC(W) : Sensible heat capacity  
 SHF : Sensible heat factor

**HEATING CAPACITY**

**PCA-RP•GA / PUHZ-RP•VHA PUHZ-RP•VHA<sub>1</sub>**

Service Ref.	Indoor Intake air D.B.(°C)	Outdoor intake air W.B.(°C)											
		-10		-5		0		5		10		15	
		CA	P.C.	CA	P.C.	CA	P.C.	CA	P.C.	CA	P.C.	CA	P.C.
PCA-RP2GA	15	3493	1.01	3795	1.11	4235	1.28	5555	1.54	6270	1.71	6985	1.85
	20	3355	1.09	3630	1.20	4015	1.39	5363	1.66	6050	1.85	6738	1.98
	25	3245	1.16	3520	1.30	3850	1.50	5060	1.76	5830	1.98	6490	2.13
PCA-RP2.5GA	15	4445	1.20	4830	1.32	5390	1.52	7070	1.83	7980	2.03	8890	2.19
	20	4270	1.30	4620	1.42	5110	1.64	6825	1.97	7700	2.19	8575	2.35
	25	4130	1.38	4480	1.54	4900	1.79	6440	2.09	7420	2.34	8260	2.53
PCA-RP3GA	15	5080	1.43	5520	1.58	6160	1.82	8080	2.19	9120	2.43	10160	2.62
	20	4880	1.56	5280	1.70	5840	1.97	7800	2.36	8800	2.62	9800	2.82
	25	4720	1.65	5120	1.85	5600	2.14	7360	2.50	8480	2.81	9440	3.03
PCA-RP4GA	15	7112	1.92	7728	2.12	8624	2.45	11312	2.93	12768	3.26	14224	3.52
	20	6832	2.09	7392	2.28	8176	2.64	10920	3.16	12320	3.52	13720	3.78
	25	6608	2.22	7168	2.48	7840	2.87	10304	3.36	11872	3.77	13216	4.06
PCA-RP5GA	15	8890	2.56	9660	2.82	10780	3.26	14140	3.91	15960	4.34	17780	4.69
	20	8540	2.78	9240	3.04	10220	3.52	13650	4.21	15400	4.69	17150	5.03
	25	8260	2.95	8960	3.30	9800	3.82	12880	4.47	14840	5.01	16520	5.40
PCA-RP6GA	15	10160	2.71	11040	2.99	12320	3.45	16160	4.14	18240	4.60	20320	4.97
	20	9760	2.94	10560	3.22	11680	3.73	15600	4.46	17600	4.97	19600	5.34
	25	9440	3.13	10240	3.50	11200	4.05	14720	4.74	16960	5.31	18880	5.73

NOTE : CA: Capacity(W) P.C. : Power consumption(kW)

**PCA-RP•GA / PUH-P•VGAA PUH-P•YGAA PUH-P•VGAA.UK PUH-P•YGAA.UK  
PUH-P•VGAA<sub>1</sub>.UK PUH-P•YGAA<sub>1</sub>.UK**

Service Ref.	Indoor Intake air D.B.(°C)	Outdoor intake air W.B.(°C)											
		-10		-5		0		5		10		15	
		CA	P.C.	CA	P.C.	CA	P.C.	CA	P.C.	CA	P.C.	CA	P.C.
PCA-RP2GA	15	3937	1.39	4278	1.53	4774	1.77	6262	2.12	7068	2.36	7874	2.55
	20	3782	1.51	4092	1.65	4526	1.91	6045	2.29	6820	2.55	7595	2.74
	25	3658	1.60	3968	1.79	4340	2.08	5704	2.43	6572	2.73	7316	2.94
PCA-RP2.5GA	15	4604	1.57	5003	1.73	5583	2.00	7323	2.39	8265	2.66	9208	2.87
	20	4423	1.70	4785	1.86	5293	2.15	7069	2.58	7975	2.87	8881	3.09
	25	4278	1.81	4640	2.02	5075	2.34	6670	2.74	7685	3.07	8555	3.31
PCA-RP3GA	15	5810	2.05	6314	2.26	7046	2.61	9242	3.13	10431	3.48	11621	3.76
	20	5582	2.23	6039	2.44	6680	2.82	8921	3.38	10065	3.76	11209	4.04
	25	5399	2.37	5856	2.64	6405	3.06	8418	3.58	9699	4.02	10797	4.33
PCA-RP4GA	15	6731	2.25	7314	2.48	8162	2.86	10706	3.43	12084	3.81	13462	4.11
	20	6466	2.44	6996	2.67	7738	3.09	10335	3.70	11660	4.11	12985	4.42
	25	6254	2.59	6784	2.90	7420	3.35	9752	3.92	11236	4.40	12508	4.74
PCA-RP5GA	15	9398	3.01	10212	3.32	11396	3.83	14948	4.60	16872	5.11	18796	5.52
	20	9028	3.27	9768	3.58	10804	4.14	14430	4.96	16280	5.52	18130	5.93
	25	8732	3.47	9472	3.88	10360	4.50	13616	5.26	15688	5.90	17464	6.36
PCA-RP6GA	15	10795	3.68	11730	4.06	13090	4.68	17170	5.62	19380	6.24	21590	6.74
	20	10370	3.99	11220	4.37	12410	5.05	16575	6.05	18700	6.74	20825	7.24
	25	10030	4.24	10880	4.74	11900	5.49	15640	6.43	18020	7.21	20060	7.77

NOTE : CA: Capacity(W) P.C. : Power consumption(kW)

## 5-2. PERFORMANCE CURVE

PCA-RP•GA / PUHZ-RP•VHA PUHZ-RP•VHA<sub>1</sub>

Cooling performance curve(50Hz)

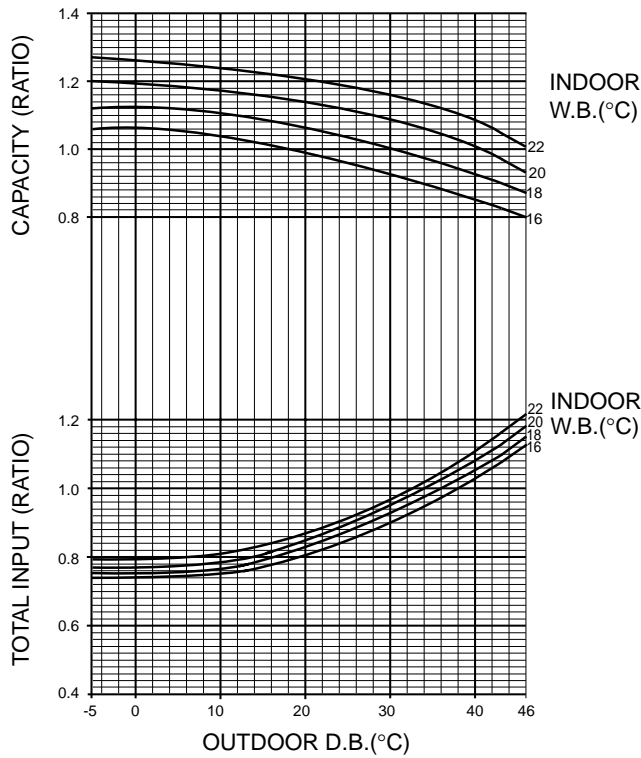

Heating performance curve(50Hz)

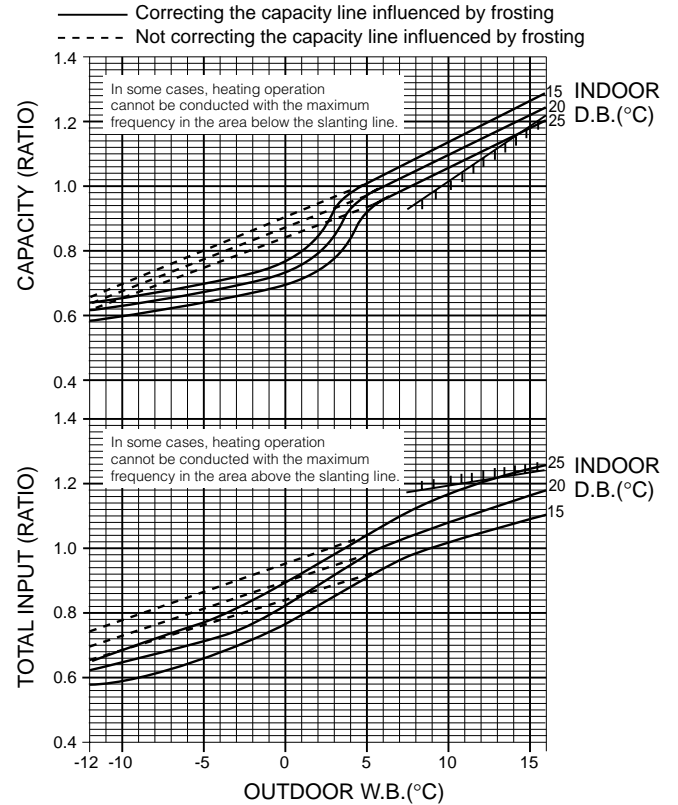

PCA-RP•GA / PUH-P•VGAA PUH-P•YGAA  
PU-P•VGAA PU-P•YGAA

PUH-P•VGAA.UK PUH-P•YGAA.UK  
PU-P•VGAA.UK PU-P•YGAA.UK  
PUH-P•VGAA<sub>1</sub>.UK PU-P•YGAA<sub>1</sub>.UK  
PU-P•VGAA<sub>1</sub>.UK PU-P•YGAA<sub>1</sub>.UK

Cooling performance curve(50Hz)

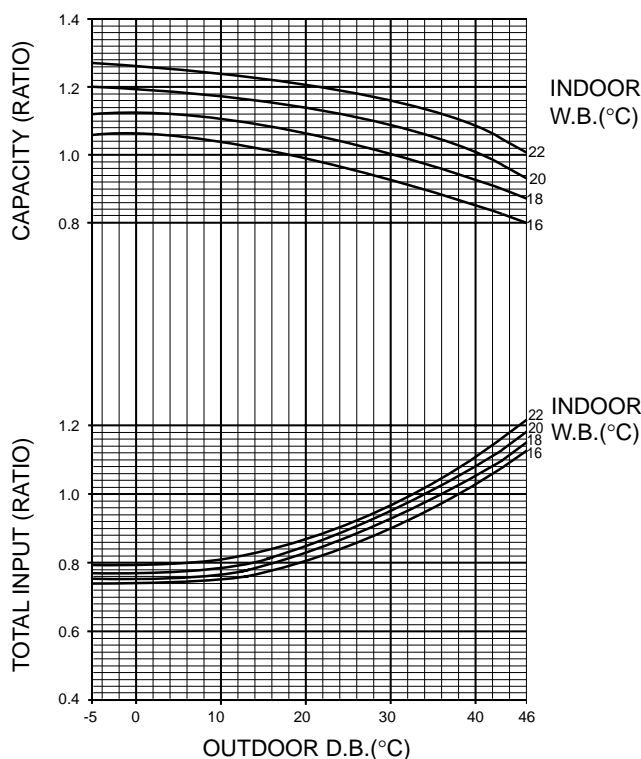

Heating performance curve(50Hz)

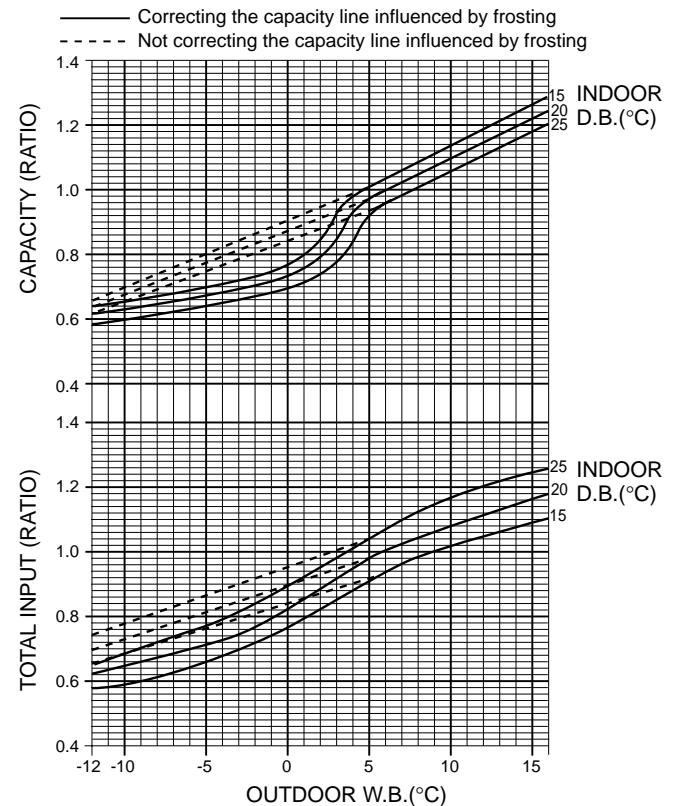

### 5-3. CORRECTION FACTORS

PCA-RP•GA / PUHZ-RP•VHA PUHZ-RP•VHA<sub>1</sub>  
Cooling capacity correction factors

Service Ref.	Refrigerant piping length (one way)									
	5m	10m	20m	30m	40m	50m	55m	60m	70m	80m
PCA-RP2GA	1.00	0.985	0.957	0.931	0.908	0.886	0.876	—	—	—
PCA-RP2.5GA	1.00	0.992	0.976	0.962	0.949	0.936	0.930	—	—	—
PCA-RP3GA	1.00	0.988	0.966	0.946	0.929	0.913	0.905	—	—	—
PCA-RP4GA	1.00	0.985	0.957	0.931	0.908	0.886	0.876	0.865	0.846	0.829
PCA-RP5GA	1.00	0.981	0.946	0.914	0.885	0.858	0.845	0.834	0.812	0.792
PCA-RP6GA	1.00	0.976	0.931	0.893	0.858	0.827	0.813	0.800	0.775	0.753

#### Heating capacity correction factors

Service Ref.	Refrigerant piping length (one way)									
	5m	10m	20m	30m	40m	50m	55m	60m	70m	80m
PCA-RP2GA	1.00	0.997	0.991	0.985	0.979	0.973	0.970	—	—	—
PCA-RP2.5GA	1.00	0.997	0.991	0.985	0.979	0.973	0.970	—	—	—
PCA-RP3GA	1.00	0.997	0.991	0.985	0.979	0.973	0.970	—	—	—
PCA-RP4GA	1.00	0.997	0.991	0.985	0.979	0.973	0.970	0.967	0.961	0.955
PCA-RP5GA	1.00	0.997	0.991	0.985	0.979	0.973	0.970	0.967	0.961	0.955
PCA-RP6GA	1.00	0.997	0.991	0.885	0.979	0.973	0.970	0.967	0.961	0.955

PCA-RP•GA / PUH-P•VGAA

PUH-P•VGAA.UK

PUH-P•VGAA<sub>1</sub>.UK

PU-P•VGAA

PU-P•VGAA.UK

PU-P•VGAA<sub>1</sub>.UK

PUH-P•YGAA

PUH-P•YGAA.UK

PUH-P•YGAA<sub>1</sub>.UK

PU-P•YGAA

PU-P•YGAA.UK

PU-P•YGAA<sub>1</sub>.UK

#### Cooling capacity correction factors

Service Ref.	Refrigerant piping length (one way)					
	5m	10m	20m	30m	40m	50m
PCA-RP2GA	1.00	0.993	0.978	0.961	0.948	—
PCA-RP2.5GA	1.00	0.989	0.970	0.950	0.930	0.910
PCA-RP3GA	1.00	0.981	0.952	0.925	0.900	0.874
PCA-RP4GA	1.00	0.989	0.970	0.950	0.930	0.910
PCA-RP5GA	1.00	0.981	0.952	0.925	0.900	0.874
PCA-RP6GA	1.00	0.975	0.935	0.900	0.869	0.840

#### Heating capacity correction factors

Service Ref.	Refrigerant piping length (one way)					
	5m	10m	20m	30m	40m	50m
PCA-RP2GA	1.00	0.998	0.993	0.988	0.983	—
PCA-RP2.5GA	1.00	0.998	0.993	0.988	0.983	—
PCA-RP3GA	1.00	0.998	0.993	0.988	0.983	0.978
PCA-RP4GA	1.00	0.998	0.993	0.988	0.983	0.978
PCA-RP5GA	1.00	0.998	0.993	0.988	0.983	0.978
PCA-RP6GA	1.00	0.998	0.993	0.988	0.983	0.978

## 5-4. STANDARD OPERATION DATA

Heat pump type(1)

Rating Conditions (ISO T1)

Service Ref.			PCA-RP2GA		PCA-RP2.5GA		PCA-RP3GA		PCA-RP4GA		PCA-RP5GA		PCA-RP6GA			
Mode			Cooling	Heating	Cooling	Heating	Cooling	Heating	Cooling	Heating	Cooling	Heating	Cooling	Heating		
Total	Capacity	W	4700	5500	6000	7000	7100	8000	10000	11200	12500	14000	14000	16000		
	Input	KW	1.67	1.71	1.63	2.03	2.14	2.43	2.92	3.26	3.89	4.34	4.96	4.60		
Electrical circuit	Indoor unit Service Ref.		PCA-RP2GA		PCA-RP2.5GA		PCA-RP3GA		PCA-RP4GA		PCA-RP5GA		PCA-RP6GA			
	Phase, Hz		1, 50		1, 50		1, 50		1, 50		1, 50		1, 50			
	Volts		V		230		230		230		230		230			
	Amperes		A		0.41	0.41	0.53	0.53	0.53	0.53	0.69	0.69	1.01	1.01	1.01	1.01
	Outdoor unit Service Ref.		PUHZ-RP2VHA		PUHZ-RP2.5VHA		PUHZ-RP3VHA		PUHZ-RP4VHA		PUHZ-RP5VHA		PUHZ-RP6VHA			
	Phase, Hz		1, 50		1, 50		1, 50		1, 50		1, 50		1, 50			
	Volts		V		230		230		230		230		230			
	Amperes		A		7.08	7.25	6.78	8.57	9.06	10.36	12.40	13.92	16.43	18.44	21.22	19.61
Refrigerant circuit	Discharge pressure		MPa		2.96	2.98	2.57	3.09	2.67	3.27	2.58	2.78	2.74	3.21	2.84	2.83
	Suction pressure		MPa		0.83	0.66	0.98	0.75	0.91	0.73	0.90	0.73	0.88	0.69	0.86	0.66
	Discharge temperature		°C		78	79	64	78	69	82	69	78	74	82	80	78
	Condensing temperature		°C		50	46	43	47	45	49	44	46	46	46	47	45
	Suction temperature		°C		4.8	-1.4	10.5	2.1	8.9	1.5	9.0	3.3	8.3	0.8	10.1	-0.2
	Ref. pipe length		m		5	5	5	5	5	5	5	5	5	5	5	5
Indoor side	Intake air temperature		D.B.	°C	27	20	27	20	27	20	27	20	27	20	27	20
			W.B.	°C	19	15	19	15	19	15	19	15	19	15	19	15
	Discharge air temperature		D.B.	°C	13.6	43.0	13.9	41.0	12.8	44.2	12.5	44.5	13.3	42.3	12.3	45.8
Outdoor side	Intake air temperature		D.B.	°C	35	7	35	7	35	7	35	7	35	7	35	7
			W.B.	°C	24	6	24	6	24	6	24	6	24	6	24	6
SHF					0.76	—	0.81	—	0.74	—	0.75	—	0.77	—	0.74	—
BF					0.11	—	0.08	—	0.09	—	0.06	—	0.08	—	0.06	—

The unit of pressure has been changed to MPa on the international system of unit (SI unit system).

The converted score against the traditional unit system can be gotten according to the formula below.

$$1(\text{MPa})=10.2(\text{kgf/cm}^2)$$

Heat pump type(2)  
Rating Conditions (ISO T1)

Service Ref.			PCA-RP2GA		PCA-RP2.5GA		PCA-RP3GA		PCA-RP4GA		PCA-RP5GA		PCA-RP6GA			
Mode			Cooling	Heating	Cooling	Heating	Cooling	Heating	Cooling	Heating	Cooling	Heating	Cooling	Heating		
Total	Capacity	W	5350	6200	6600	7250	7450	9150	9600	10600	12300	14800	14200	17000		
	Input	KW	2.35	2.36	2.62	2.66	3.37	3.48	3.62	3.81	4.91	5.11	5.89	6.24		
Electrical circuit	Indoor unit Service Ref.		PCA-RP2GA		PCA-RP2.5GA		PCA-RP3GA		PCA-RP4GA		PCA-RP5GA		PCA-RP6GA			
	Phase, Hz		1, 50		1, 50		1, 50		1, 50		1, 50		1, 50			
	Volts		230		230		230		230		230		230			
	Amperes		A		0.41	0.41	0.53	0.53	0.53	0.53	0.69	0.69	1.01	1.01	1.01	1.01
	Outdoor unit Service Ref.		PUH-P2VGAA		PUH-P2.5VGAA		PUH-P3VGAA		PUH-P4VGAA		PUH-P5YGAA		PUH-P6YGAA			
			PUH-P2VGAA.UK		PUH-P2.5VGAA.UK		PUH-P3VGAA.UK		PUH-P4VGAA.UK		PUH-P5YGAA.UK		PUH-P6YGAA.UK			
			PUH-P2YGAA.UK		PUH-P2.5YGAA.UK		PUH-P3YGAA.UK		PUH-P4YGAA.UK		PUH-P5YGAA.UK		PUH-P6YGAA.UK			
			PUH-P2YGAA.UK		PUH-P2.5YGAA.UK		PUH-P3YGAA.UK		PUH-P4YGAA.UK		PUH-P5YGAA.UK		PUH-P6YGAA.UK			
	Phase, Hz		V		1/3, 50		1/3, 50		1/3, 50		3, 50		3, 50			
	Volts		A		230/400		230/400		230/400		400		400			
Amperes		MPa		10.82/3.32	10.87/3.34	11.99/3.63	12.18/3.69	15.57/4.82	16.10/5.00	16.61/5.06	17.51/5.36	6.79	7.10	8.34	8.90	
Refrigerant circuit	Discharge pressure		MPa		2.30	2.23	2.08	2.14	2.28	2.51	1.94	2.04	2.17	2.26	2.30	2.22
	Suction pressure		°C		0.48	0.43	0.50	0.42	0.44	0.40	0.50	0.40	0.44	0.41	0.46	0.42
	Discharge temperature		°C		86	88	78	82	86	88	75	67	76	78	79	74
	Condensing temperature		°C		41	50	49	48	52	52	47	46	51	46	51	48
	Suction temperature		m		3.5	0.3	6.0	0.7	3.5	-0.5	10.0	0.2	4.2	0.5	4.0	-0.5
	Ref. pipe length		°C		5	5	5	5	5	5	5	5	5	5	5	5
Indoor side	Intake air temperature	D.B.	°C		27	20	27	20	27	20	27	20	27	20	27	20
		W.B.	°C		19	15	19	15	19	15	19	15	19	15	19	15
Discharge air temperature		D.B.	°C		12.6	46.4	13.6	41.9	12.3	48.2	12.8	43.1	13.5	44.0	12.1	47.7
Outdoor side	Intake air temperature	D.B.	°C		35	7	35	7	35	7	35	7	35	7	35	7
		W.B.	°C		24	6	24	6	24	6	24	6	24	6	24	6
SHF			0.72	—	0.75	—	0.73	—	0.76	—	0.77	—	0.74	—		
BF			0.09	—	0.08	—	0.08	—	0.06	—	0.07	—	0.07	—		

The unit of pressure has been changed to MPa on the international system of unit (SI unit system).  
The converted score against the traditional unit system can be gotten according to the formula below.  
1(MPa)=10.2(kgf/cm<sup>2</sup>)

Cooling only type  
Rating Conditions (ISO T1)

Service Ref.			PCA-RP2GA	PCA-RP2.5GA	PCA-RP3GA	PCA-RP4GA	PCA-RP5GA	PCA-RP6GA	
Mode			Cooling	Cooling	Cooling	Cooling	Cooling	Cooling	
Total	Capacity	W	5350	6600	7450	9600	12300	14200	
	Input	KW	2.35	2.62	3.37	3.62	4.91	5.89	
Indoor unit Service Ref.			PCA-RP2GA	PCA-RP2.5GA	PCA-RP3GA	PCA-RP4GA	PCA-RP5GA	PCA-RP6GA	
Phase, Hz			1, 50	1, 50	1, 50	1, 50	1, 50	1, 50	
Volts		V	230	230	230	230	230	230	
Amperes		A	0.41	0.53	0.53	0.69	1.01	1.01	
Outdoor unit Service Ref.			PU-P2VGAA PU-P2VGAA.UK PU-P2VGAA;.UK	PU-P2.5VGAA PU-P2.5VGAA.UK PU-P2.5VGAA;.UK	PU-P3VGAA PU-P3VGAA.UK PU-P3VGAA;.UK	PU-P4VGAA PU-P4VGAA.UK PU-P4VGAA;.UK	PU-P5YGAA PU-P5YGAA.UK PU-P5YGAA;.UK	PU-P6YGAA PU-P6YGAA.UK PU-P6YGAA;.UK	
Phase, Hz			V 1/3, 50	V 1/3, 50	V 1/3, 50	V 1/3, 50	V 3, 50	V 3, 50	
Volts		A	230/400	230/400	230/400	230/400	415	415	
Amperes		MPa	10.82/3.32	11.99 / 3.63	15.57 / 4.82	16.61 / 5.06	6.79	8.34	
Refrigerant circuit			MPa	°C	°C	°C	°C	°C	
Discharge pressure			2.30	2.08	2.28	1.94	2.17	2.30	
Suction pressure			0.48	0.50	0.44	0.50	0.44	0.46	
Discharge temperature			86	78	86	75	76	79	
Condensing temperature			41	49	52	47	51	51	
Suction temperature			m	3.5	6.0	3.5	10.0	4.2	4.0
Ref. pipe length			°C	5	5	5	5	5	
Indoor side			D.B. °C	27	27	27	27	27	
Intake air temperature			W.B. °C	19	19	19	19	19	
Discharge air temperature			D.B. °C	12.6	13.6	12.3	12.8	13.5	12.1
Outdoor side			D.B. °C	35	35	35	35	35	
Intake air temperature			W.B. °C	24	24	24	24	24	
SHF			0.72	0.75	0.73	0.76	0.77	0.74	
BF			0.09	0.08	0.08	0.06	0.07	0.07	

The unit of pressure has been changed to MPa on the international system of unit (SI unit system).  
The converted score against the traditional unit system can be gotten according to the formula below.  
1(MPa)=10.2(kgf/cm<sup>2</sup>)

## 5-5. OUTLET AIR SPEED AND COVERAGE RANGE

		PCA-RP2GA	PCA-RP2.5GA	PCA-RP3GA	PCA-RP4GA	PCA-RP5GA	PCA-GP6GA
Air flow	m <sup>3</sup> /min	13	18	18	25	34	34
Air speed	m/sec	3.7	3.8	3.8	4.1	4.4	4.4
Coverage range	m	8.8	10.4	10.4	12.6	15.2	15.2

## 5-6. NOISE CRITERION CURVES

### PCA-RP2GA

NOTCH	SPL(dB)	LINE
High	42	○—○
Med1	40	△—△
Med2	38	●—●
Low	37	▲—▲

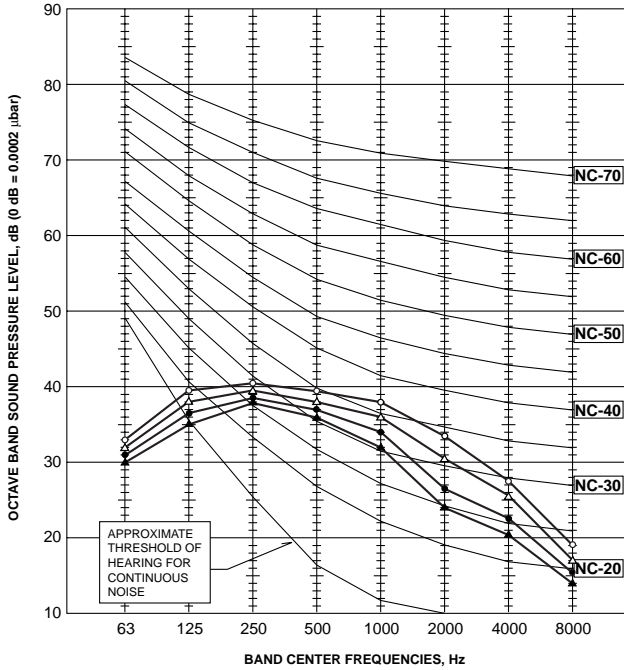

### PCA-RP2.5GA PCA-RP3GA

NOTCH	SPL(dB)	LINE
High	43	○—○
Med1	41	△—△
Med2	39	●—●
Low	37	▲—▲

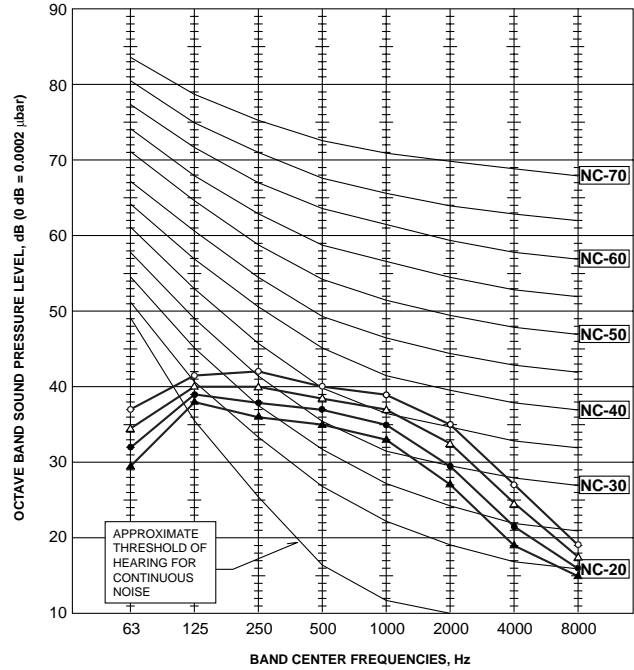

### PCA-RP4GA

NOTCH	SPL(dB)	LINE
High	45	○—○
Med1	43	△—△
Med2	41	●—●
Low	40	▲—▲

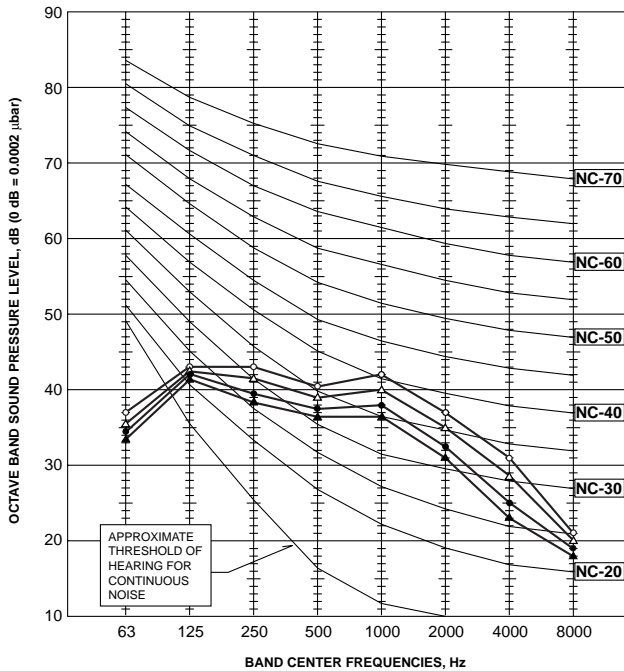

### PCA-RP5GA

NOTCH	SPL(dB)	LINE
High	46	○—○
Med1	45	△—△
Med2	43	●—●
Low	41	▲—▲

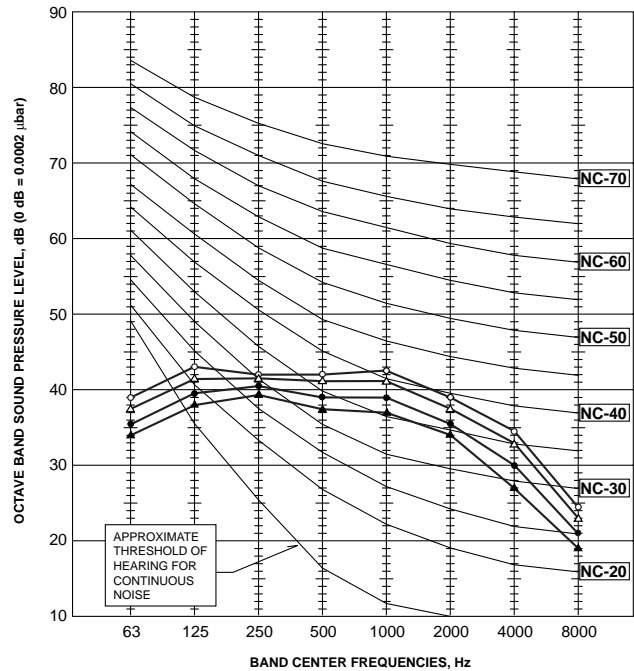



# PCA-RP6GA

NOTCH	SPL(dB)	LINE
High	48	○—○
Med1	46	△—△
Med2	44	●—●
Low	42	▲—▲

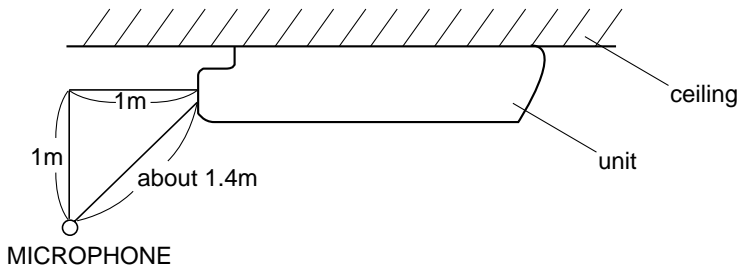
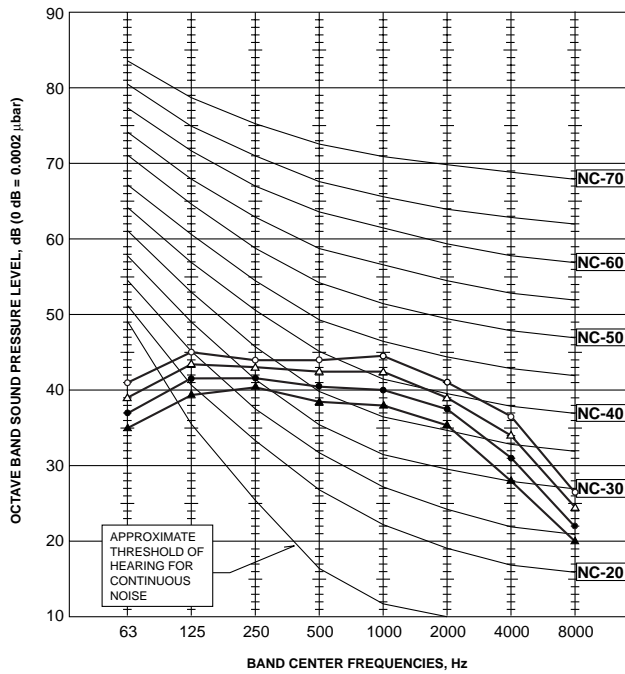

# 6

# OUTLINES AND DIMENSIONS

## INDOOR UNIT PCA-RP2GA

Unit : mm

NOTES:

1. Use M10 or W3/8 screws for anchor bolt.
2. Please be sure when installing the drain-up machine (option parts).  
Refrigerant pipe will be only upper drain pipe arrangement.

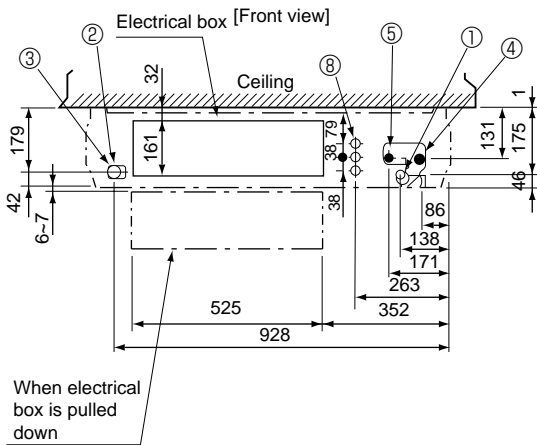
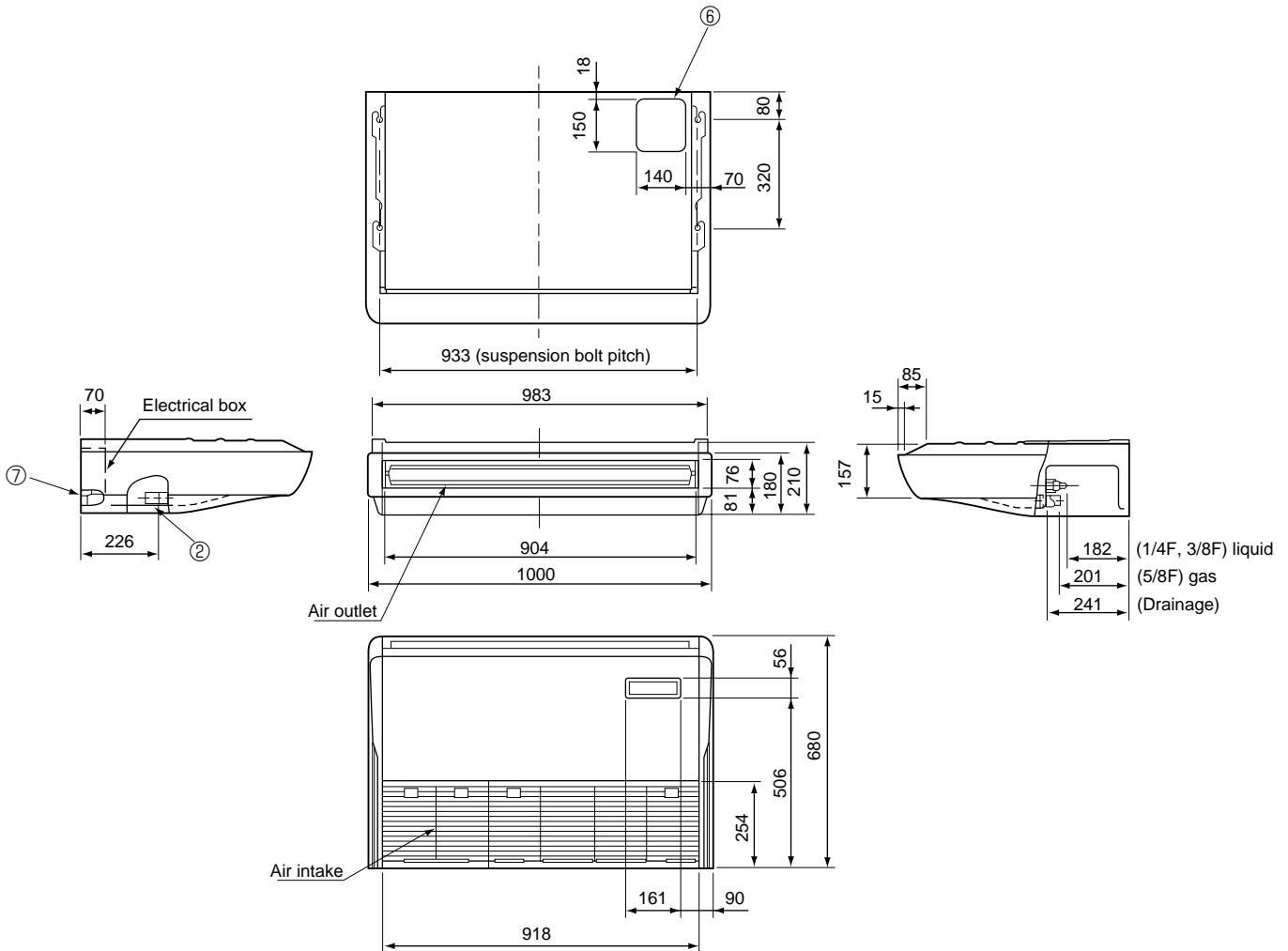

- ① Drainage pipe connection (26mm I.D.)
- ② Drainage pipe connection (for the left arrangement)
- ③ Knock out hole for left drain-piping arrangement
- ④ Refrigerant-pipe connection (gas pipe side/flared connection)
- ⑤ Refrigerant-pipe connection (liquid pipe side/flared connection)
- ⑥ Knock out hole for upper drain pipe arrangement
- ⑦ Knock out hole for left drain pipe arrangement
- ⑧ Knock out hole for wiring arrangement

**PCA-RP2.5GA**  
**PCA-RP3GA**

Unit : mm

**NOTES:**

1. Use M10 or W3/8 screws for anchor bolt.
2. Please be sure when installing the drain-up machine (option parts). Refrigerant pipe will be only upper drain pipe arrangement.

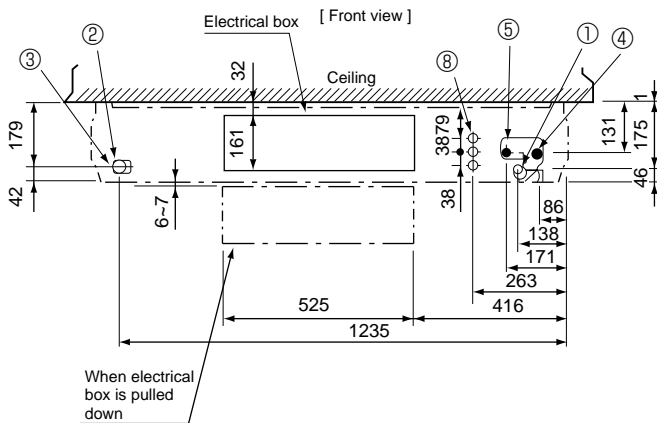
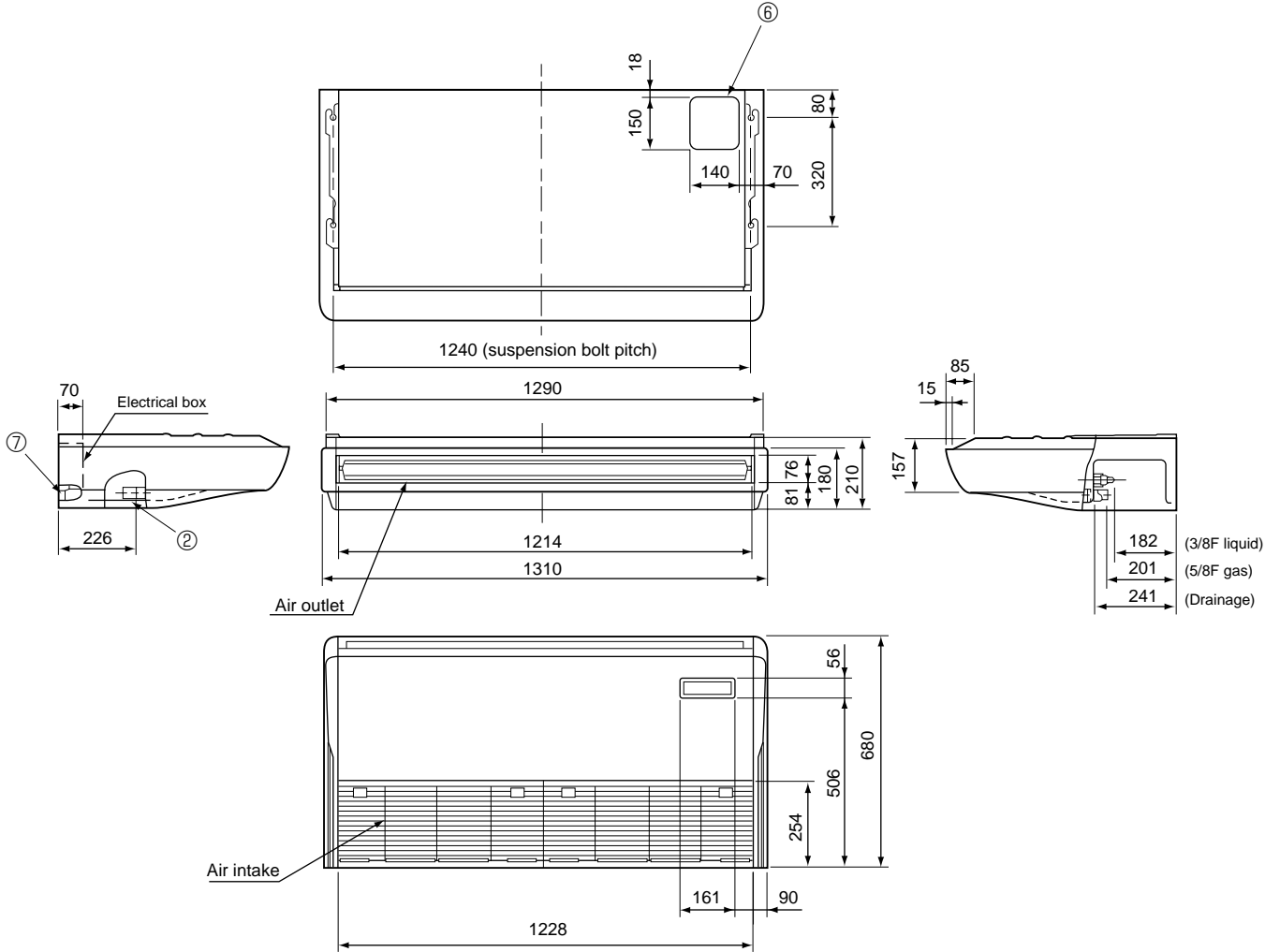

- ① Drainage pipe connection (26mm I.D.)
- ② Drainage pipe connection (for the left arrangement)
- ③ Knock out hole for left drain-piping arrangement
- ④ Refrigerant-pipe connection (gas pipe side/flared connection)
- ⑤ Refrigerant-pipe connection (liquid pipe side/flared connection)
- ⑥ Knock out hole for upper drain pipe arrangement
- ⑦ Knock out hole for left drain pipe arrangement
- ⑧ Knock out hole for wiring arrangement

# PCA-RP4GA

Unit : mm

### NOTES:

1. Use M10 or W3/8 screws for anchor bolt.
2. Please be sure when installing the drain-up machine (option parts). Refrigerant pipe will be only upper drain pipe arrangement.

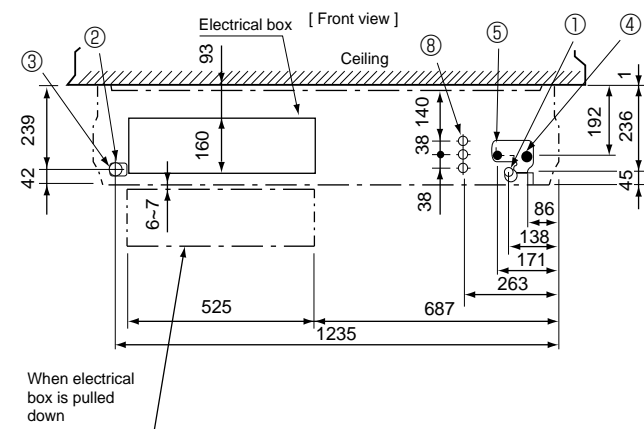
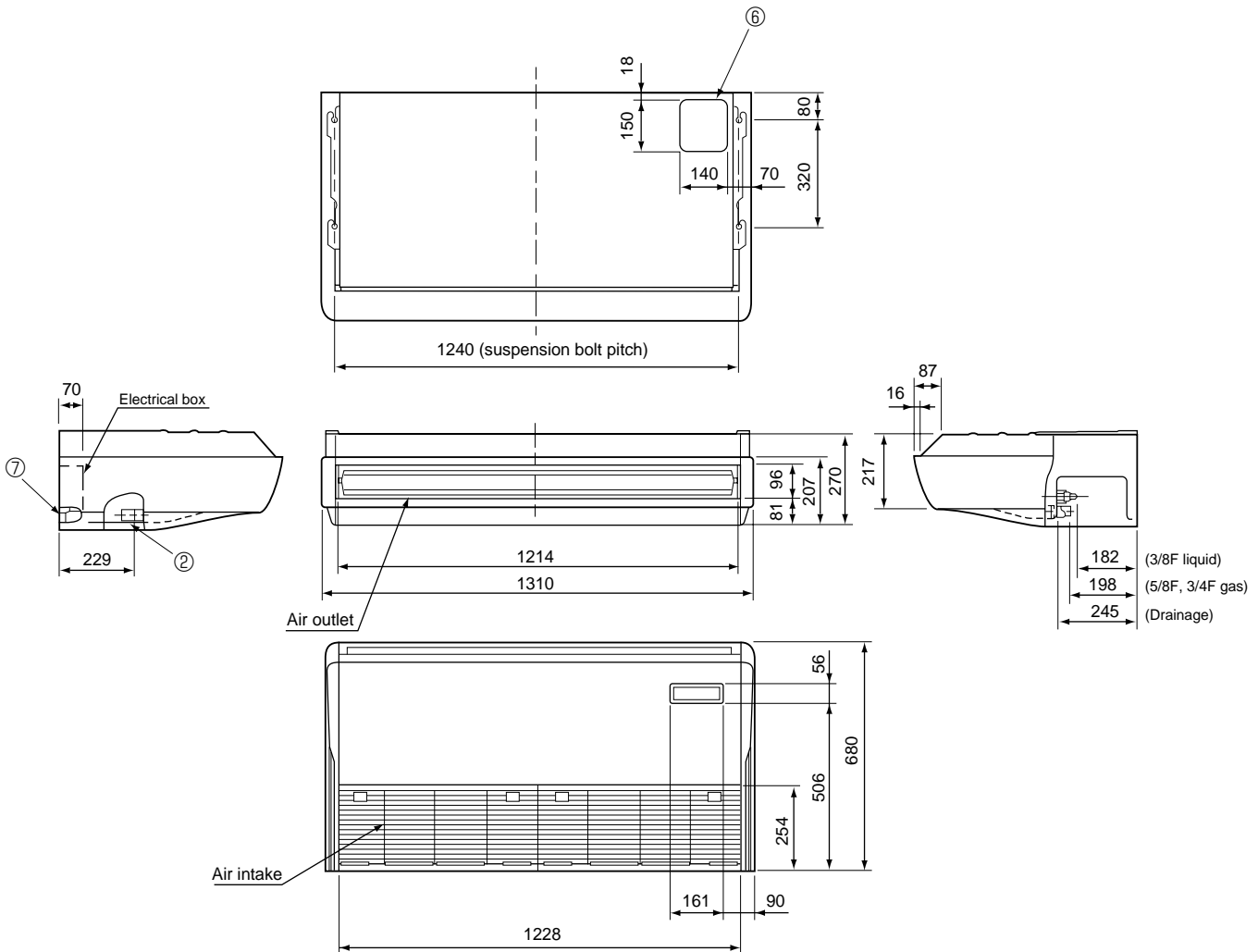

**PCA-RP5GA  
PCA-RP6GA**

Unit : mm

**NOTES:**

1. Use M10 or W3/8 screws for anchor bolt.
2. Please be sure when installing the drain-up machine (option parts).  
Refrigerant pipe will be only upper drain pipe arrangement.

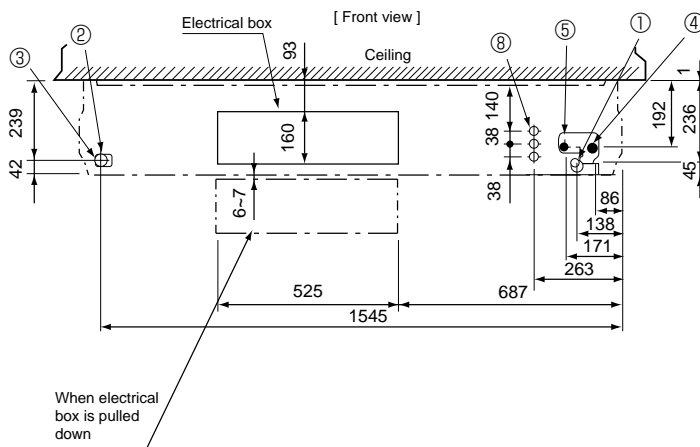
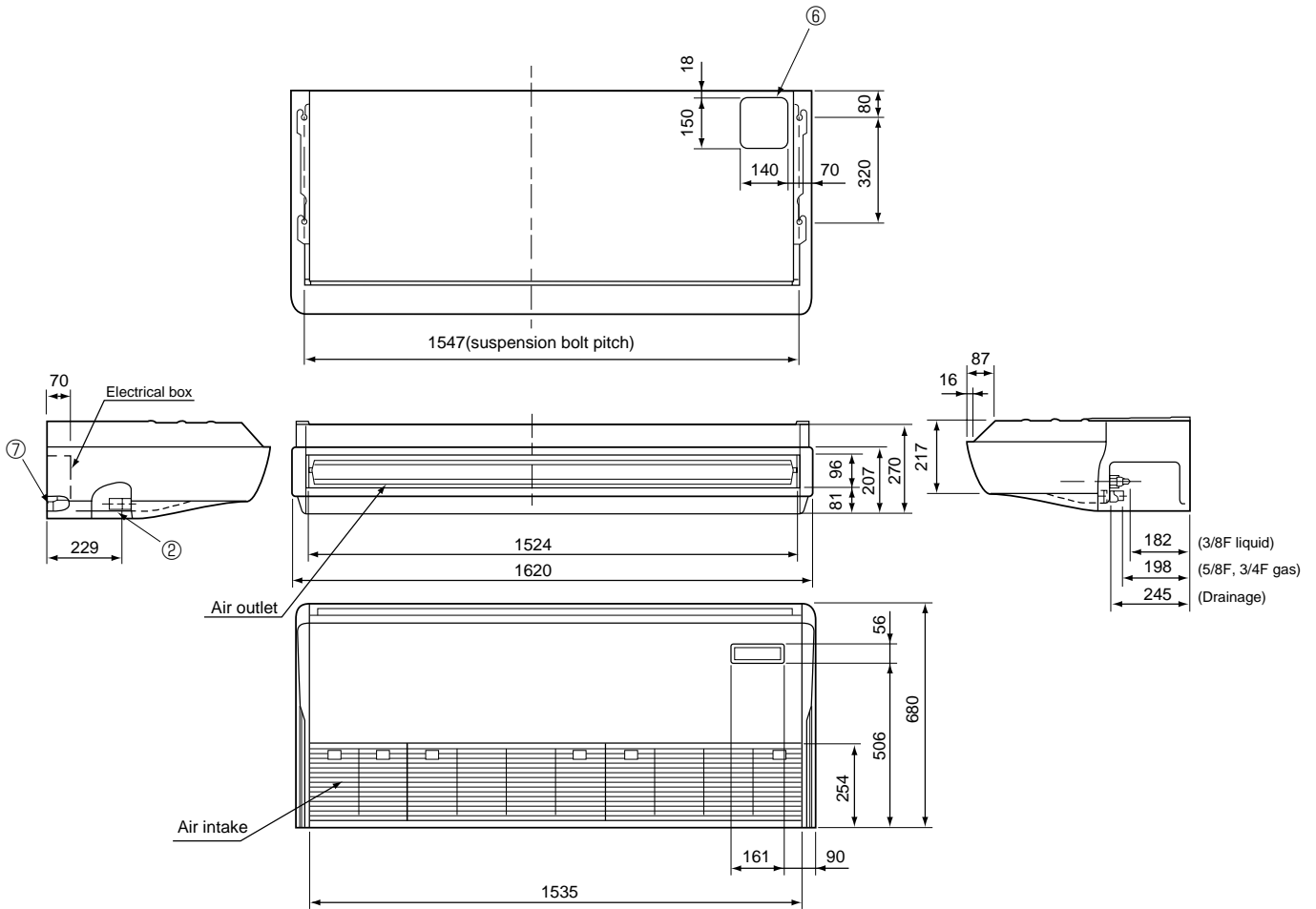

- ① Drainage pipe connection (26mm I.D.)
- ② Drainage pipe connection (for the left arrangement)
- ③ Knock out hole for left drain-piping arrangement
- ④ Refrigerant-pipe connection (gas pipe side/flared connection)
- ⑤ Refrigerant-pipe connection (liquid pipe side/flared connection)
- ⑥ Knock out hole for upper drain pipe arrangement
- ⑦ Knock out hole for left drain pipe arrangement
- ⑧ Knock out hole for wiring arrangement

PCA-RP2GA PCA-RP2.5GA PCA-RP3GA  
PCA-RP4GA PCA-RP5GA PCA-RP6GA

SYMBOL	NAME	SYMBOL	NAME	SYMBOL	NAME
P.B	INDOOR POWER BOARD	MV	VANE MOTOR	W.B	WIRELESS REMOTE CONTROLLER BOARD(OPTION)
F1	FUSE(4A)	DP	DRAIN-UP MACHINE(OPTION)	RU	RECEIVING UNIT
ZNR	VARISTOR	DS	DRAIN SENSOR(OPTION)	BZ	BUZZER
I.B	INDOOR CONTROLLER BOARD	TB4	TERMINAL BLOCK(INDOOR/OUTDOOR CONNECTING LINE)	LED1	LED(RUN INDICATOR)
CN2L	CONNECTOR(LOSSNAY)	TB5	TERMINAL BLOCK(REMOTE CONTROLLER TRANSMISSION LINE)	LED2	LED(HOT ADJUST)
CN32	CONNECTOR(REMOTE SWITCH)	TH1	ROOM TEMP.THERMISTOR (0°C/15kΩ,25°C/5.4kΩ DETECT)	SW1	SWITCH(HEATING ON/OFF)
CN41	CONNECTOR(HA TERMINAL-A)	TH2	PIPE TEMP.THERMISTOR/LIQUID (0°C/15kΩ,25°C/5.4kΩ DETECT)	SW2	SWITCH(COOLING ON/OFF)
SW1	JUMPER WIRE(MODEL SELECTION)	TH5	COND./EVA.TEMP.THERMISTOR (0°C/15kΩ,25°C/5.4kΩ DETECT)		
SW2	JUMPER WIRE(CAPACITY CORD)	R.B	REMOTE CONTROLLER BOARD		
SWE	SWITCH(EMERGENCY OPERATION)	CN2	CONNECTOR(SCHEDULE TIMER)		
X1	RELAY(DRAIN PUMP)	TB6	TERMINAL BLOCK(REMOTE CONTROLLER TRANSMISSION LINE)		
X4	RELAY(FAN MOTOR)				
FC	FAN PHASE CONTROL				
LED1	POWER SUPPLY(I.B)				
LED2	POWER SUPPLY(R.B)				
LED3	TRANSMISSION(INDOOR-OUTDOOR)				
C	CAPACITOR(FAN MOTOR)	TB2	TERMINAL BLOCK(HEATER)		
MF	FAN MOTOR				

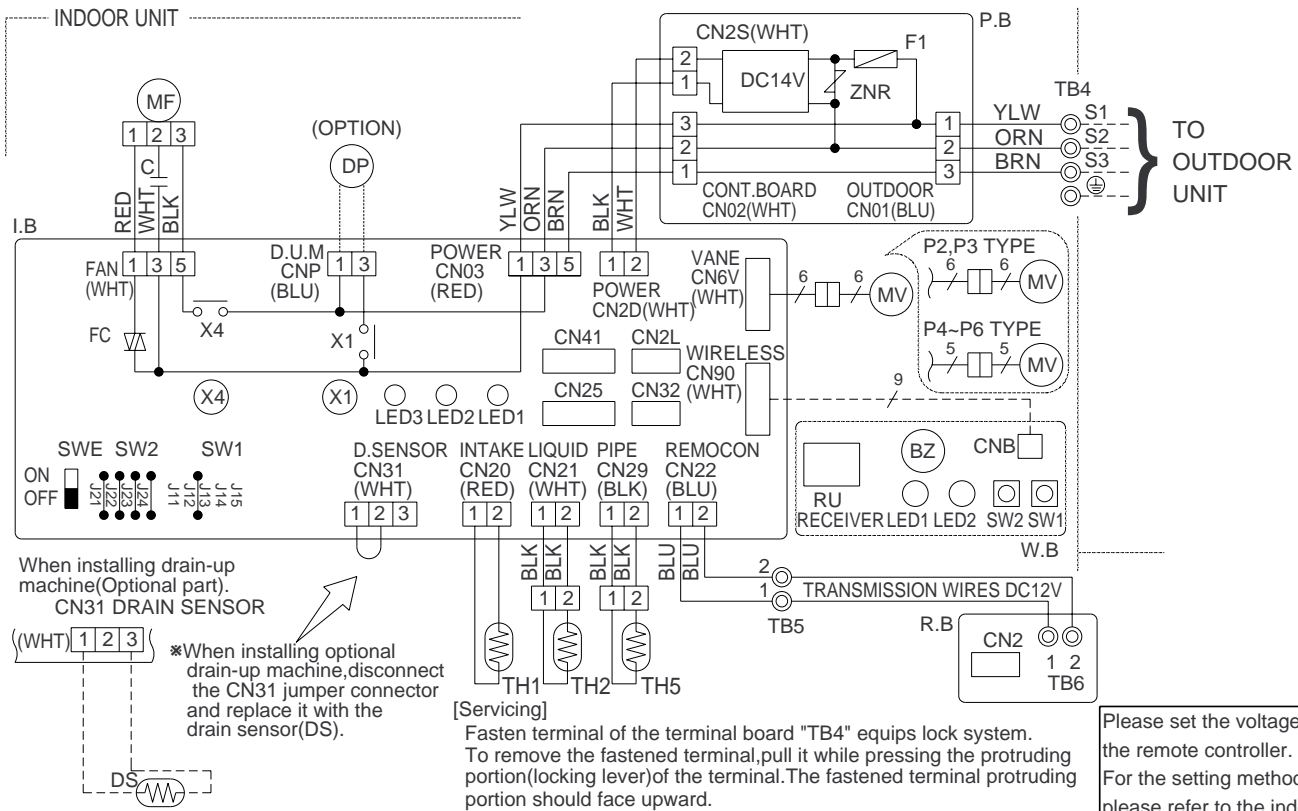

MODELS	SW1	SW2	
		Manufacture	Service board
2GA	<For manufacture> J11 J12 J13 J14 J15	J21 J22 J23 J24	1 2 3 4 ON OFF
2.5GA		J21 J22 J23 J24	1 2 3 4 ON OFF
3GA		J21 J22 J23 J24	1 2 3 4 ON OFF
4GA	<For service board>	J21 J22 J23 J24	1 2 3 4 ON OFF
5GA		J21 J22 J23 J24	1 2 3 4 5 ON OFF
6GA		J21 J22 J23 J24	1 2 3 4 ON OFF

[Self-diagnosis]

- For details on how to operate self-diagnosis with the wireless remote control, refer to the technical manuals etc.

NOTES:

- Since the outdoor side electric wiring may change be sure to check the outdoor unit electric wiring for servicing.
- Indoor and outdoor connecting wires are made with polarities, make wiring matching terminal numbers(S1, S2, S3).
- Make sure that the main power supply of the booster heater is independent.
- Symbols used in wiring diagram above are,  
□ : Connector, ⊙ : Terminal (block).

[Emergency operation procedure]

- When the wired remote control or the indoor unit microcomputer has failed, but all other components work properly, if you set the switch(SWE) on the indoor control panel ON, the indoor unit will begin Emergency Operation. When Emergency Operation is activated, the indoor unit operates as follows:  
(1) Indoor fan is running at high speed.  
(2) Drain-up machine(optional) is working.

# 8

# REFRIGERANT SYSTEM DIAGRAM

PCA-RP2GA PCA-RP2.5GA PCA-RP3GA  
PCA-RP4GA PCA-RP5GA PCA-RP6GA

Unit : mm

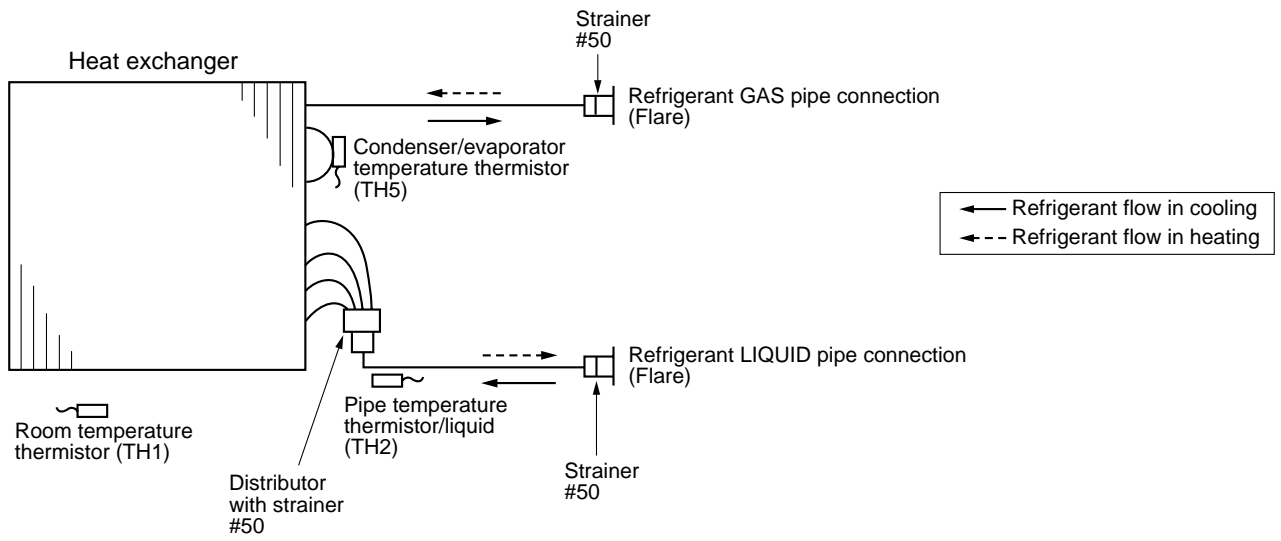

### 9-1. TROUBLESHOOTING

#### <Error code display by self-diagnosis and actions to be taken for service (summary)>

Present and past error codes are logged and displayed on the wired remote controller or controller board of outdoor unit. Actions to be taken for service and the inferior phenomenon reoccurrence at field are summarised in the table below. Check the contents below before investigating details.

Unit conditions at service	Error code	Actions to be taken for service (summary)
The inferior phenomenon is reoccurring.	Displayed	Judge what is wrong and take a corrective action according to 9-2. "Self-diagnosis action table".
	Not displayed	Identify the cause of the inferior phenomenon and take a corrective action according to 9-3. "Trouble shooting by inferior phenomena".
The inferior phenomenon is not reoccurring.	Logged	<ul style="list-style-type: none"> <li>①Consider the temporary defects such as the work of protection devices in the refrigerant circuit including compressor, poor connection of wiring, noise and etc. Re-check the symptom, and check the installation environment, refrigerant amount, weather when the inferior phenomenon occurred, and wiring related.</li> <li>②Reset error code logs and restart the unit after finishing service.</li> <li>③There is no abnormality in electrical components, controller boards, and remote controller.</li> </ul>
	Not logged	<ul style="list-style-type: none"> <li>①Recheck the abnormal symptom.</li> <li>②Identify the cause of the inferior phenomenon and take a corrective action according to 9-3. "Trouble shooting by inferior phenomena".</li> <li>③Continue to operate unit for the time being if the cause is not ascertained.</li> <li>④There is no abnormality in electrical components, controller boards, remote controller etc.</li> </ul>



Note: Refer to the manual of outdoor unit for the details of display such as F, U, and other E.

## 9-2. SELF-DIAGNOSIS ACTION TABLE

Error Code	Meaning of error code and detection method	Cause	Countermeasure
P1	<p><b>Abnormality of room temperature thermistor (TH1)</b></p> <p>① The unit is in three-minute resume prevention mode if short/open of thermistor is detected. Abnormal if the unit does not reset normally after three minutes. (The unit returns to normal operation, if it has normally reset.)</p> <p>② Constantly detected during cooling, drying, and heating operation. Short: 90°C or more Open: -40°C or less</p>	<p>① Defective thermistor characteristics.</p> <p>② Contact failure of connector (CN20) on the indoor controller board. (Insert failure)</p> <p>③ Breaking of wire or contact failure of thermistor wiring.</p> <p>④ Defective indoor controller board.</p>	<p>①-③ Check resistance value of thermistor. 0°C .....15.0kΩ 10°C ....9.6kΩ 20°C ....6.3kΩ 30°C ....4.3kΩ 40°C ....3.0kΩ</p> <p>If you put force on (draw or bend) the lead wire with measuring resistance value of thermistor breaking of wire or contact failure can be detected.</p> <p>② Check contact failure of connector (CN20) on the indoor controller board. Refer to 9-6-2. Turn the power on again and check restart after inserting connector again.</p> <p>④ Check room temperature display on remote controller. Replace indoor controller board if there is abnormal difference with actual room temperature.</p> <p>Turn the power off, and on again to operate after check.</p>
P2	<p><b>Abnormality of pipe temperature thermistor/Liquid (TH2)</b></p> <p>① The unit is in three-minute resume prevention mode if short/open of thermistor is detected. Abnormal if the unit does not reset normally after three minutes. (The unit returns to normal operation, if it has normally reset.)</p> <p>② Constantly detected during cooling, drying, and heating (except defrosting) operation. Short: 90°C or more Open: -40°C or less</p>	<p>① Defective thermistor characteristics.</p> <p>② Contact failure of connector (CN21) on the indoor controller board. (Insert failure)</p> <p>③ Breaking of wire or contact failure of thermistor wiring.</p> <p>④ Defective refrigerant circuit is causing thermistor temperature of 90°C or more or -40°C or less.</p> <p>⑤ Defective indoor controller board.</p>	<p>①-③ Check resistance value of thermistor. For characteristics, refer to (P1) above.</p> <p>② Check contact failure of connector (CN21) on the indoor controller board. Refer to 9-6-2. Turn the power on and check restart after inserting connector again.</p> <p>④ Check pipe &lt;liquid&gt; temperature with remote controller in test run mode. If pipe &lt;liquid&gt; temperature is exclusively low (in cooling mode) or high (in heating mode), refrigerant circuit may have defective.</p> <p>⑤ Check pipe &lt;liquid&gt; temperature with remote controller in test run mode. If there is exclusive difference with actual pipe &lt;liquid&gt; temperature, replace indoor controller board.</p> <p>Turn the power off, and on again to operate after check.</p>
P4	<p><b>Abnormality of drain sensor (DS)</b></p> <p>① Suspensive abnormality, if short/open of thermistor is detected for 30 seconds continuously. Turn off compressor and indoor fan.</p> <p>② Short/open is detected for 30 seconds continuously during suspensive abnormality. (The unit returns to normal operation, if it has normally reset.)</p> <p>③ Detect the following condition.</p> <ul style="list-style-type: none"> <li>• During cooling and drying operation.</li> <li>• In case that pipe &lt;liquid&gt; temperature - room temperature &lt;-10 deg (Except defrosting)</li> <li>• When pipe &lt;liquid&gt; temperature or room temperature is short/open temperature.</li> <li>• During drain pump operation.</li> </ul>	<p>① Defective thermistor characteristics</p> <p>② Contact failure of connector (CN31) on the indoor controller board. (Insert failure).</p> <p>③ Breaking of wire or contact failure of drain sensor wiring.</p> <p>④ Defective indoor controller board.</p>	<p>①-③ Check resistance value of thermistor. 0°C .....6.0kΩ 10°C ....3.9kΩ 20°C ....2.6kΩ 30°C ....1.8kΩ 40°C ....1.3kΩ</p> <p>② Check contact failure of connector (CN31) on the indoor controller board. Refer to 9-6-2. Turn the power on again and check restart after inserting connector again.</p> <p>④ Replace indoor controller board if drain pump operates with the line of drain sensor connector CN31-① and ② is short-circuited, and abnormality reappears.</p> <p>Turn the power off, and on again to operate after check.</p>
P5	<p><b>Malfunction of drain pump (DP)</b></p> <p>① Suspensive abnormality, if thermistor of drain sensor is let heat itself and temperature rises slightly. Turn off compressor and indoor fan.</p> <p>② Drain pump is abnormal if the condition above is detected during suspensive abnormality.</p> <p>③ Constantly detected during drain pump operation.</p>	<p>① Malfunction of drain pump</p> <p>② Defective drain Clogged drain pump Clogged drain pipe</p> <p>③ Attached drop of water at the drain sensor</p> <ul style="list-style-type: none"> <li>• Drops of drain trickles from lead wire.</li> <li>• Clogged filter is causing wave of drain.</li> </ul> <p>④ Defective indoor controller board.</p>	<p>① Check if drain-up machine works.</p> <p>② Check drain function.</p> <p>③ Check the setting of lead wire of drain sensor and check clogs of the filter.</p> <p>④ Replace indoor controller board if drain pump operates with the line of drain sensor connector CN31-① and ② is short-circuited and abnormality reappears. Refer to 9-6-2.</p> <p>Turn the power off, and on again to operate after check.</p>

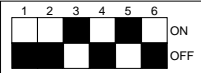
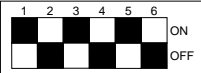
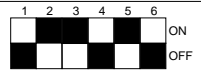
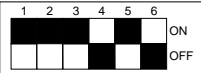
Error Code	Meaning of error code and detection method	Cause	Countermeasure
P6	<p><b>Freezing/overheating protection is working</b></p> <p>① Freezing protection (Cooling mode) The unit is in six-minute resume prevention mode if pipe &lt;liquid or condenser/evaporator&gt; temperature stays under -15°C for three minutes, three minutes after the compressor started. Abnormal if it stays under -15°C for three minutes again within 16 minutes after six-minute resume prevention mode.</p> <p>② Overheating protection (Heating mode) The units is in six-minute resume prevention mode if pipe &lt;condenser / evaporator&gt; temperature is detected as over 74°C after the compressor started. Abnormal if the temperature of over 74°C is detected again within 10 minutes after six-minute resume prevention mode.</p>	<p>(Cooling or drying mode)</p> <p>① Clogged filter (reduced airflow) ② Short cycle of air path ③ Low-load (low temperature) operation beyond the tolerance range ④ Defective indoor fan motor • Fan motor is defective. • Indoor controller board is defective.</p> <p>⑤ Overcharge of refrigerant ⑥ Defective refrigerant circuit (clogs)</p> <p>(Heating mode)</p> <p>① Clogged filter (reduced airflow) ② Short cycle of air path ③ Over-load (high temperature) operation beyond the tolerance range ④ Defective indoor fan motor • Fan motor is defective. • Indoor controller board is defective.</p> <p>⑤ Overcharge of refrigerant ⑥ Defective refrigerant circuit (clogs) ⑦ Bypass circuit of outdoor unit is defective.</p>	<p>(Cooling or drying mode)</p> <p>① Check clogs of the filter. ② Remove shields.</p> <p>④ Measure the resistance of fan motor's winding. Measure the output voltage of fan's connector (FAN) on the indoor controller board. *The indoor controller board should be normal when voltage of AC 100~240V is detected while fan motor is connected. Refer to 9-6-2. ⑤⑥ Check operating condition of refrigerant circuit.</p> <p>(Heating mode)</p> <p>① Check clogs of the filter. ② Remove shields.</p> <p>④ Measure the resistance of fan motor's winding. Measure the output voltage of fan's connector (FAN) on the indoor controller board. *The indoor controller board should be normal when voltage of AC 220~240V is detected while fan motor is connected. Refer to 9-6-2. ⑤~⑦ Check operating condition of refrigerant circuit.</p>
P8	<p><b>Abnormality of pipe temperature</b> &lt;Cooling mode&gt; Detected as abnormal when the pipe temperature is not in the cooling range 3 minutes later of compressor start and 6 minutes later of the liquid or condenser/evaporator pipe is out of cooling range. Note 1) It takes at least 9 min. to detect. Note 2) Abnormality P8 is not detected in drying mode. Cooling range : Indoor pipe temperature (TH2 or TH5) – intake temperature (TH1) <math>\leq</math> -3 deg TH: Lower temperature between: liquid pipe temperature and condenser/evaporator temperature</p> <p>&lt;Heating mode&gt; When 10 seconds have passed after the compressor starts operation and the hot adjustment mode has finished, the unit is detected as abnormal when condenser/evaporator pipe temperature is not in heating range within 20 minutes.</p> <p>Note 3) It takes at least 27 minutes to detect abnormality. Note 4) It excludes the period of defrosting (Detection restarts when defrosting mode is over) Heating range : 3 deg <math>\leq</math> (Condenser/ Evaporator temperature(TH5) – intake temperature(TH1))</p>	<p>① Slight temperature difference between indoor room temperature and pipe &lt;liquid or condenser / evaporator&gt; temperature thermistor • Shortage of refrigerant • Disconnected holder of pipe &lt;liquid or condenser / evaporator&gt; thermistor • Defective refrigerant circuit</p> <p>② Converse connection of extension pipe (on plural units connection)</p> <p>③ Converse wiring of indoor/outdoor unit connecting wire (on plural units connection)</p> <p>④ Defective detection of indoor room temperature and pipe &lt;condenser / evaporator&gt; temperature thermistor</p> <p>⑤ Stop valve is not opened completely.</p>	<p>①~④ Check pipe &lt;liquid or condenser / evaporator&gt; temperature with room temperature display on remote controller and outdoor controller circuit board. Pipe &lt;liquid or condenser / evaporator&gt; temperature display is indicated by setting SW2 of outdoor controller circuit board as follows.</p> <p>(Conduct temperature check with outdoor controller circuit board after connecting 'A-Control Service Tool(PAC-SK52ST)').</p> <div style="display: flex; justify-content: space-around;"> <div style="text-align: center;"> <p>Temperature display of indoor liquid pipe Indoor 1</p>  </div> <div style="text-align: center;"> <p>Temperature display of indoor condenser/evaporator pipe Indoor 1</p>  </div> </div> <div style="display: flex; justify-content: space-around;"> <div style="text-align: center;"> <p>Temperature display of indoor liquid pipe Indoor 2</p>  </div> <div style="text-align: center;"> <p>Temperature display of indoor condenser/evaporator pipe Indoor 2</p>  </div> </div> <p style="text-align: center;">A-Control Service Tool SW2 setting</p> <p>②③ Check converse connection of extension pipe or converse wiring of indoor/outdoor unit connecting wire.</p>



Error Code	Meaning of error code and detection method	Cause	Countermeasure
P9	<p><b>Abnormality of pipe temperature thermistor / Condenser-Evaporator (TH5)</b></p> <p>① The unit is in three-minute resume protection mode if short/open of thermistor is detected. Abnormal if the unit does not get back to normal within three minutes. (The unit returns to normal operation, if it has normally reset.)</p> <p>② Constantly detected during cooling, drying, and heating operation (except defrosting) Short: 90°C or more Open: -40°C or less</p>	<p>① Defective thermistor characteristics</p> <p>② Contact failure of connector (CN29) on the indoor controller board. (Insert failure)</p> <p>③ Breaking of wire or contact failure of thermistor wiring.</p> <p>④ Temperature of thermistor is 90°C or more or -40°C or less caused by defective refrigerant circuit.</p> <p>⑤ Defective indoor controller board.</p>	<p>①-③ Check resistance value of thermistor. For characteristics, refer to (P1) above.</p> <p>② Check contact failure of connector (CN29) on the indoor controller board. Refer to 9-6-2. Turn the power on and check restart after inserting connector again.</p> <p>④ Operate in test run mode and check pipe &lt;condenser / evaporator&gt; temperature with outdoor controller circuit board. If pipe &lt;condenser / evaporator&gt; temperature is exclusively low (in cooling mode) or high (in heating mode), refrigerant circuit may have defective.</p> <p>⑤ Operate in test run mode and check pipe &lt;condenser / evaporator&gt; temperature with outdoor control circuit board. If there is exclusive difference with actual pipe &lt;condenser / evaporator&gt; temperature replace indoor controller board. There is no abnormality if none of above comes within the unit. Turn the power off and on again to operate.</p> <p>( In case of checking pipe temperature with outdoor controller circuit board, be sure to connect A-control service tool (PAC-SK52ST). )</p> <div style="display: flex; justify-content: space-around;"> <div style="text-align: center;"> <p>Temperature display of indoor condenser/ evaporator pipe Indoor 1</p> </div> <div style="text-align: center;"> <p>Temperature display of indoor condenser/ evaporator pipe Indoor 2</p> </div> </div> <p style="text-align: center; font-size: small;">A-Control Service Tool SW2 setting</p>
E4	<p><b>Remote controller signal receiving error</b></p> <p>① Abnormal if indoor controller board can not receive normally any data from remote controller or from other indoor controller board for three minutes.</p> <p>② Indoor control board cannot receive any signal from remote controller for two minutes.</p>	<p>① Contact failure at transmission wire of remote controller</p> <p>② All remote controllers are set as "sub" remote controller. In this case, E0 is displayed on remote controller, and E4 is displayed at LED (LED1, LED2) on the outdoor controller circuit board.</p> <p>③ Defective transmitting receiving circuit of remote controller</p> <p>④ Defective transmitting receiving circuit of indoor controller board.</p> <p>⑤ Noise has entered into the transmission wire of remote controller.</p>	<p>① Check disconnection or looseness of indoor unit or transmission wire of remote controller.</p> <p>② Set one of the remote controllers "main". If there is no problem with the action above.</p> <p>③ Diagnose remote controllers.</p> <p>a) When "RC OK" is displayed, Remote controllers have no problem. Put the power off, and on again to check. If abnormality generates again, replace indoor controller board.</p> <p>b) When "RC NG" is displayed, Replace remote controller.</p> <p>c) When "RC E3" is displayed,</p> <p>d) When "ERC 00-06" is displayed, [ c),d)→Noise may be causing abnormality. ]</p> <p>* If the unit is not normal after replacing indoor controller board in group control, indoor controller board of address "0" may be abnormal.</p>
E5	<p><b>Remote controller transmitting error</b></p> <p>① Abnormal if indoor controller board cannot check the blank of transmission path for three minutes.</p> <p>② Abnormal if indoor controller board cannot finish transmitting 30 times consecutively.</p>	<p>① Defective transmitting receiving circuit of indoor controller board.</p> <p>② Noise has entered into the transmission wire of remote controller.</p>	<p>①② Turn the power off, and on again to check. If abnormality generates again, replace indoor controller board.</p>
E6	<p><b>Indoor/outdoor unit communication error (Signal receiving error)</b></p> <p>① Abnormal if indoor controller board cannot receive any signal normally for six minutes after putting the power on.</p> <p>② Abnormal if indoor controller board cannot receive any signal normally for three minutes.</p> <p>③ Consider the unit abnormal under the following condition: When two or more indoor units are connected to one outdoor unit, indoor controller board cannot receive a signal for three minutes from outdoor controller circuit board, a signal which allows outdoor controller circuit board to transmit signals.</p>	<p>① Contact failure, short circuit or, mis-wiring (converse wiring) of indoor/outdoor unit connecting wire</p> <p>② Defective transmitting receiving circuit of indoor controller board</p> <p>③ Defective transmitting receiving circuit of indoor controller board</p> <p>④ Noise has entered into indoor/ outdoor unit connecting wire.</p>	<p>* Check LED display on the outdoor control circuit board. (Connect A-control service tool, PAC-SK52ST.) Refer to EA-EC item if LED displays EA-EC.</p> <p>① Check disconnection or looseness of indoor/ outdoor unit connecting wire of indoor unit or outdoor unit. Check all the units in case of twin triple indoor unit system.</p> <p>②-④ Turn the power off, and on again to check. If abnormality generates again, replace indoor controller board or outdoor controller circuit board.</p> <p>* Other indoor controller board may have defective in case of twin triple indoor unit system.</p>
E7	<p><b>Indoor/outdoor unit communication error (Transmitting error)</b></p> <p>Abnormal if "1" receiving is detected 30 times continuously though indoor controller board has transmitted "0".</p>	<p>① Defective transmitting receiving circuit of indoor controller board</p> <p>② Noise has entered into power supply.</p> <p>③ Noise has entered into outdoor control wire.</p>	<p>①-③ Turn the power off, and on again to check. If abnormality generates again, replace indoor controller board.</p>

### 9-3. TROUBLESHOOTING BY INFERIOR PHENOMENA

Note: Refer to the manual of outdoor unit for the detail of remote controller.

Phenomena	Cause	Countermeasure
(1)LED2 on indoor controller board is off.	<ul style="list-style-type: none"> <li>• When LED1 on indoor controller board is also off.</li> </ul> <p>① Power supply of 220~240V is not supplied to outdoor unit.</p> <p>② Defective outdoor controller circuit board.</p> <p>③ Power supply of 220~240V is not supplied to indoor unit.</p> <p>④ Defective indoor power board.</p> <p>⑤ Defective indoor controller board.</p>	<p>① Check the voltage of outdoor power supply terminal block (L, N)</p> <ul style="list-style-type: none"> <li>• When AC 220~240V is not detected. Check the power wiring to outdoor unit and the breaker.</li> <li>• When AC 220~240V is detected. —Check ② (below).</li> </ul> <p>② Check the voltage between outdoor terminal block S1 and S2.</p> <ul style="list-style-type: none"> <li>• When AC 220~240V is not detected. Check the fuse on outdoor controller circuit board (10A). Check the wiring connection.</li> <li>• When AC 220~240V is detected. —Check ③ (below).</li> </ul> <p>③ Check the voltage between indoor terminal block S1 and S2.</p> <ul style="list-style-type: none"> <li>• When AC 220~240V is not detected. Check indoor/outdoor unit connecting wire for mis-wiring.</li> <li>• When AC 220~240V is detected. —Check ④ (below).</li> </ul> <p>④ Check voltage output from CN2S on indoor power board (DC14V). Refer to 9-6-1.</p> <ul style="list-style-type: none"> <li>• When no voltage is output. Check the fuse on indoor power board. Check the wiring connection.</li> <li>• When output voltage is between 12V and 16V. —Check ⑤ (below).</li> </ul> <p>⑤ Check the wiring connection between indoor controller board and indoor power board. If no problems are found, indoor controller board is defective.</p>
	<ul style="list-style-type: none"> <li>• When LED1 on indoor controller board is lit.</li> </ul> <p>① Mis-setting of refrigerant address for outdoor unit (There is no unit corresponding to refrigerant address "0".)</p>	<p>① Reconfirm the setting of refrigerant address for outdoor unit Set the refrigerant address to "0". (For grouping control system under which 2 or more outdoor units are connected, set one of the units to "0".) Set refrigerant address using SW1 (2-6) on outdoor controller circuit board.</p>
(2)LED2 on indoor controller board is blinking.	<ul style="list-style-type: none"> <li>• When LED1 on indoor controller board is also blinking. Connection failure of indoor/outdoor unit connecting wire</li> <li>• When LED1 is lit. Mis-wiring of remote controller wires Under twin triple indoor unit system, 2 or more indoor units are wired together.</li> </ul> <p>① Refrigerant address for outdoor unit is wrong or not set. Under grouping control system, there are some units whose refrigerant address is 0.</p> <p>② Short-cut of remote controller wires</p> <p>③ Defective remote controller</p>	<p>Check indoor/outdoor unit connecting wire for connection failure. Check the connection of remote controller wires in case of twin triple indoor unit system. When 2 or more indoor units are wired in one refrigerant system, connect remote controller wires to one of those units.</p> <p>① Check the setting of refrigerant address in case of grouping control system. If there are some units whose refrigerant addresses are 0 in one group, set one of the units to 0 using SW1 (2-6) on outdoor controller circuit board.</p> <p>②③ Remove remote controller wires and check LED2 on indoor controller board.</p> <ul style="list-style-type: none"> <li>• When LED2 is blinking, check the short-cut of remote controller wires.</li> <li>• When LED2 is lit, connect remote controller wires again and: if LED2 is blinking, remote controller is defective; if LED2 is lit, connection failure of remote controller terminal block etc. has returned to normal.</li> </ul>
(3)Upward/downward vane performance failure	<p>① The vane is not downward during defrosting and heat preparation and when the thermostat is OFF in HEAT mode. (Working of COOL protection function)</p> <p>② Vane motor does not rotate.</p> <ul style="list-style-type: none"> <li>• Defective vane motor</li> <li>• Breaking of wire or connection failure of connector</li> </ul> <p>③ Upward/downward vane does not work.</p> <ul style="list-style-type: none"> <li>• The vane is set to fixed position.</li> </ul>	<p>① Normal operation (The vane is set to horizontal regardless of remote control.)</p> <p>② Check ② (left).</p> <ul style="list-style-type: none"> <li>• Check the vane motor. (Refer to "How to check the parts".)</li> <li>• Check for breaking of wire or connection failure of connector.</li> </ul> <p>③ Normal operation (Each connector on vane motor side is disconnected.)</p>

## 9-4. When wired remote controller or indoor unit micro computer troubles

1. If there is not any other wrong when trouble occurs, emergency operation starts as the indoor controller board switch (SWE) is set to ON.

During the emergency operation the indoor unit is as follows;

- (1) Indoor fan high speed operation                      (2) Drain-up machine operation

2. When emergency operating for COOL or HEAT, setting of the switch (SWE) in the indoor controller board and outdoor unit emergency operation are necessary.

3. Check items and notices as the emergency operation

(1) Emergency operation cannot be used as follows;

- When the outdoor unit is something wrong.
- When the indoor fan is something wrong.
- When drain over flow protected operation is detected during self-diagnosis. (Error code : P5)

(2) Emergency operation will be serial operation by the power supply ON/OFF.

ON/OFF or temperature, etc. adjustment is not operated by the remote controller.

(3) Do not operate for a long time as cold air is blown when the outdoor unit starts defrosting operation during heat emergency operation.

(4) Cool emergency operation must be within 10 hours at most. It may cause heat exchanger frosting in the indoor unit.

(5) After completing the emergency operation, return the switch setting, etc. in former state.

(6) Since vane does not work at emergency operation, position the vane manually and slowly.

## 9-5. HOW TO CHECK THE PARTS

PCA-RP2GA

PCA-RP2.5GA

PCA-RP3GA

PCA-RP4GA

PCA-RP5GA

PCA-RP6GA

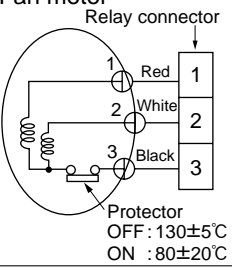
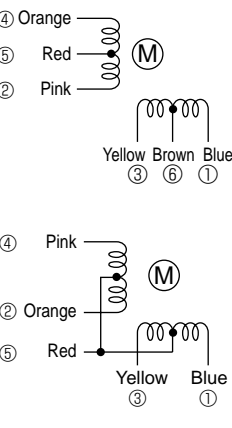
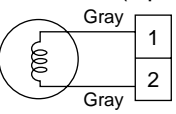
Parts name	Check points																							
Room temperature thermistor (TH1) Pipe temperature thermistor (TH2) Condenser/evaporator temperature thermistor (TH5)	Disconnect the connector then measure the resistance using a tester. (Surrounding temperature 10°C ~30°C) <table border="1" style="margin-top: 10px;"> <thead> <tr> <th>Normal</th> <th>Abnormal</th> </tr> </thead> <tbody> <tr> <td>4.3kΩ~9.6kΩ</td> <td>Open or short</td> </tr> </tbody> </table> Refer to the next page for the details.	Normal	Abnormal	4.3kΩ~9.6kΩ	Open or short																			
Normal	Abnormal																							
4.3kΩ~9.6kΩ	Open or short																							
Fan motor  Relay connector Protector OFF : 130±5°C ON : 80±20°C	Measure the resistance between the terminals using a tester. (Winding temperature 20°C) <table border="1" style="margin-top: 10px;"> <thead> <tr> <th rowspan="2">Motor terminal or Relay connector</th> <th colspan="4">Normal</th> <th rowspan="2">Abnormal</th> </tr> <tr> <th>RP2</th> <th>RP2.5, RP3</th> <th>RP4</th> <th>RP5, RP6</th> </tr> </thead> <tbody> <tr> <td>Red-Black</td> <td>70.6Ω</td> <td>45.0Ω</td> <td>43.7Ω</td> <td>20.4Ω</td> <td rowspan="2">Open or short</td> </tr> <tr> <td>White-Black</td> <td>69.6Ω</td> <td>44.8Ω</td> <td>55.3Ω</td> <td>20.7Ω</td> </tr> </tbody> </table>	Motor terminal or Relay connector	Normal				Abnormal	RP2	RP2.5, RP3	RP4	RP5, RP6	Red-Black	70.6Ω	45.0Ω	43.7Ω	20.4Ω	Open or short	White-Black	69.6Ω	44.8Ω	55.3Ω	20.7Ω		
Motor terminal or Relay connector	Normal				Abnormal																			
	RP2	RP2.5, RP3	RP4	RP5, RP6																				
Red-Black	70.6Ω	45.0Ω	43.7Ω	20.4Ω	Open or short																			
White-Black	69.6Ω	44.8Ω	55.3Ω	20.7Ω																				
Vane motor 	<table border="1" style="margin-top: 10px;"> <thead> <tr> <th rowspan="2">Connector</th> <th colspan="2">Normal</th> <th rowspan="2">Abnormal</th> </tr> <tr> <th>RP2</th> <th>RP2.5, RP3</th> </tr> </thead> <tbody> <tr> <td>Brown-Yellow</td> <td rowspan="4">186~214Ω</td> <td rowspan="4">140~160Ω</td> <td rowspan="4">Open or short</td> </tr> <tr> <td>Brown-Blue</td> </tr> <tr> <td>Red-Orange</td> </tr> <tr> <td>Red-Pink</td> </tr> </tbody> </table> <table border="1" style="margin-top: 10px;"> <thead> <tr> <th rowspan="2">Connector</th> <th>Normal</th> <th rowspan="2">Abnormal</th> </tr> <tr> <th>RP4, RP5, RP6</th> </tr> </thead> <tbody> <tr> <td>Brown-Yellow</td> <td rowspan="4">140~160Ω</td> <td rowspan="4">Open or short</td> </tr> <tr> <td>Brown-Blue</td> </tr> <tr> <td>Red-Orange</td> </tr> <tr> <td>Red-Pink</td> </tr> </tbody> </table>	Connector	Normal		Abnormal	RP2	RP2.5, RP3	Brown-Yellow	186~214Ω	140~160Ω	Open or short	Brown-Blue	Red-Orange	Red-Pink	Connector	Normal	Abnormal	RP4, RP5, RP6	Brown-Yellow	140~160Ω	Open or short	Brown-Blue	Red-Orange	Red-Pink
Connector	Normal		Abnormal																					
	RP2	RP2.5, RP3																						
Brown-Yellow	186~214Ω	140~160Ω	Open or short																					
Brown-Blue																								
Red-Orange																								
Red-Pink																								
Connector	Normal	Abnormal																						
	RP4, RP5, RP6																							
Brown-Yellow	140~160Ω	Open or short																						
Brown-Blue																								
Red-Orange																								
Red-Pink																								
Drain-up mechanism (Option) 	Measure the resistance between the terminals using a tester. (Winding temperature 20°C) <table border="1" style="margin-top: 10px;"> <thead> <tr> <th>Normal</th> <th>Abnormal</th> </tr> </thead> <tbody> <tr> <td>195Ω</td> <td>Open or short</td> </tr> </tbody> </table>	Normal	Abnormal	195Ω	Open or short																			
Normal	Abnormal																							
195Ω	Open or short																							

<Thermistor Characteristic graph>

Thermistor for lower temperature

Room temperature thermistor (TH1)  
 Pipe temperature thermistor (TH2)  
 Condenser/evaporator temperature thermistor (TH5)

Thermistor  $R_0 = 15k\Omega \pm 3\%$   
 Fixed number of  $B = 3480K \pm 2\%$

$$R_t = 15 \exp \left\{ 3480 \left( \frac{1}{273+t} - \frac{1}{273} \right) \right\}$$

0°C	15kΩ
10°C	9.6kΩ
20°C	6.3kΩ
25°C	5.4kΩ
30°C	4.3kΩ
40°C	3.0kΩ

< Thermistor for lower temperature >

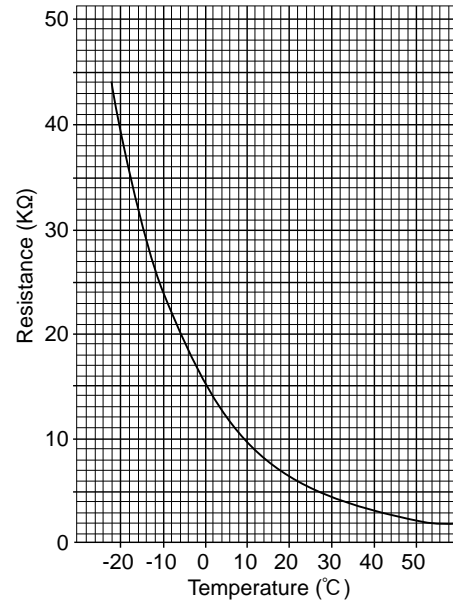

9-6. TEST POINT DIAGRAM

9-6-1. Power board

- PCA-RP2GA
- PCA-RP2.5GA
- PCA-RP3GA
- PCA-RP4GA
- PCA-RP5GA
- PCA-RP6GA

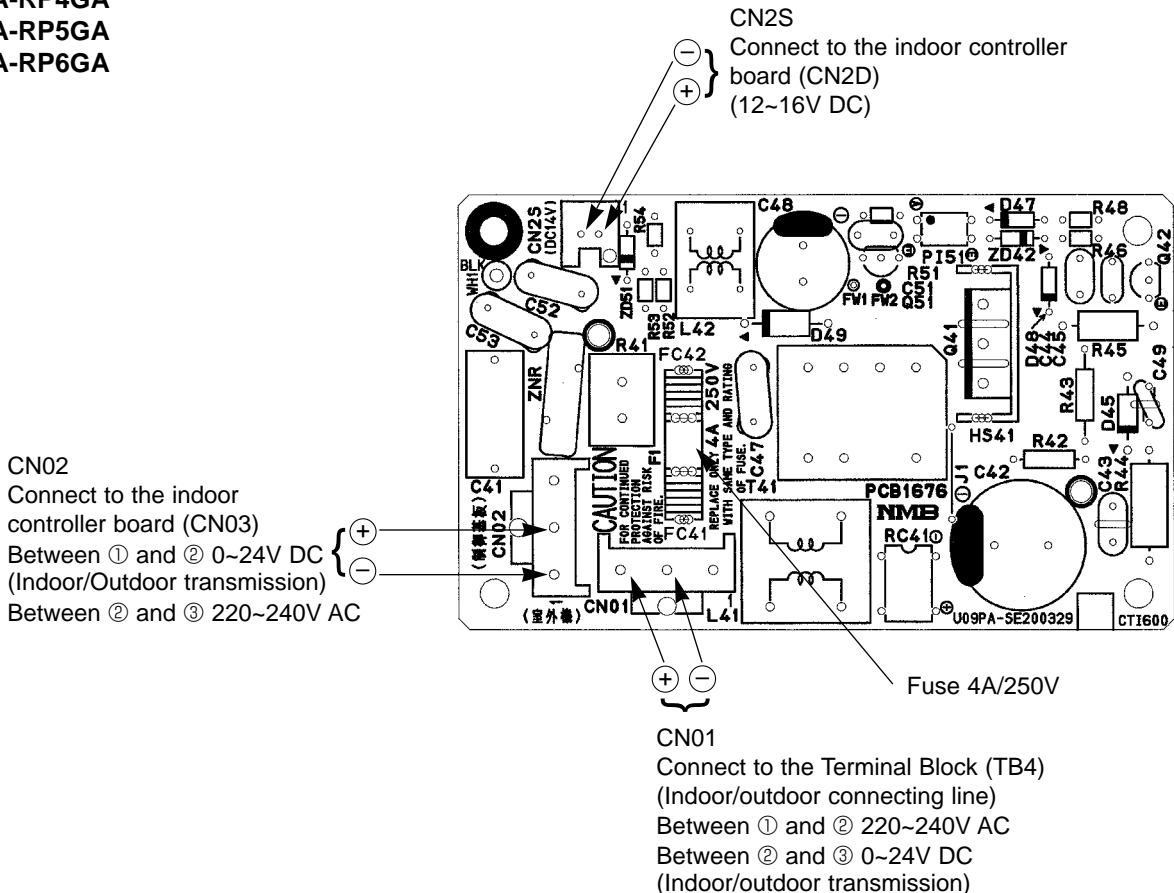

## 9-6-2. Indoor controller board

PCA-RP2GA  
PCA-RP2.5GA  
PCA-RP3GA  
PCA-RP4GA  
PCA-RP5GA  
PCA-RP6GA

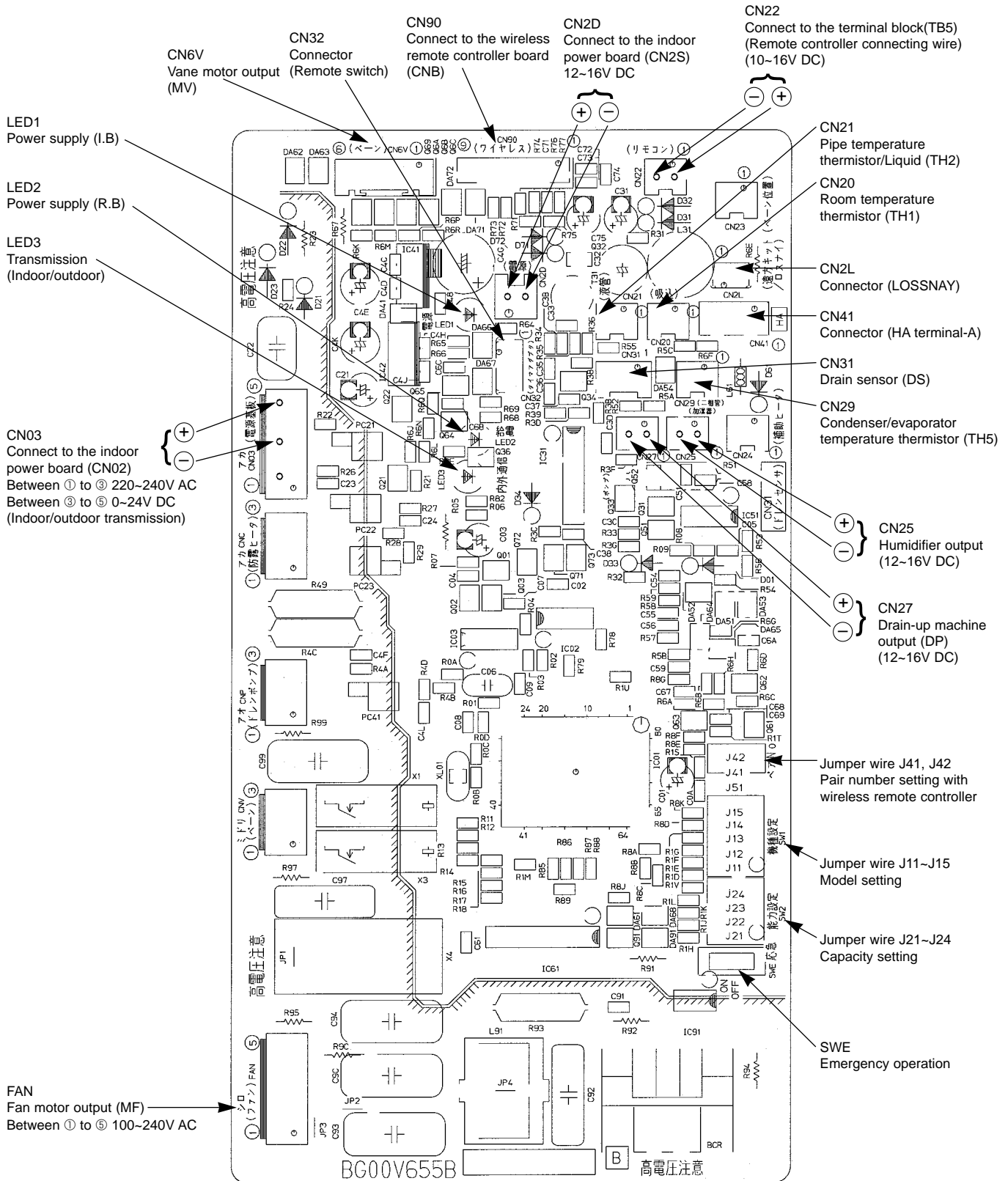



## 9-7. FUNCTIONS OF JUMPER WIRE

Each function is controlled by the jumper wire on control p.c. board. For service parts, J11- J15 and J21-J24, DIP switches (SW1 and SW2) are equipped with jumper wire.

(Marks in the table below) Jumper wire (○ : Short × : Open)  
DIP switch (○ : ON × : OFF)

Jumper wire	Functions	Open/short of jumper wire	Remarks																																			
J11~J15 (SW1)	Model settings	Models : PCA-RP2~6 <table border="1"> <thead> <tr> <th>J11</th> <th>J12</th> <th>J13</th> <th>J14</th> <th>J15</th> </tr> </thead> <tbody> <tr> <td>×</td> <td>○</td> <td>×</td> <td>×</td> <td>×</td> </tr> </tbody> </table>	J11	J12	J13	J14	J15	×	○	×	×	×																										
J11	J12	J13	J14	J15																																		
×	○	×	×	×																																		
J21~J24 (SW2)	Capacity settings	<table border="1"> <thead> <tr> <th>Models</th> <th>J21</th> <th>J22</th> <th>J23</th> <th>J24</th> </tr> </thead> <tbody> <tr> <td>RP2</td> <td>○</td> <td>×</td> <td>○</td> <td>×</td> </tr> <tr> <td>RP2.5</td> <td>○</td> <td>○</td> <td>○</td> <td>×</td> </tr> <tr> <td>RP3</td> <td>○</td> <td>×</td> <td>×</td> <td>○</td> </tr> <tr> <td>RP4</td> <td>×</td> <td>×</td> <td>○</td> <td>○</td> </tr> <tr> <td>RP5</td> <td>×</td> <td>○</td> <td>○</td> <td>○</td> </tr> <tr> <td>RP6</td> <td>○</td> <td>○</td> <td>○</td> <td>○</td> </tr> </tbody> </table>	Models	J21	J22	J23	J24	RP2	○	×	○	×	RP2.5	○	○	○	×	RP3	○	×	×	○	RP4	×	×	○	○	RP5	×	○	○	○	RP6	○	○	○	○	
Models	J21	J22	J23	J24																																		
RP2	○	×	○	×																																		
RP2.5	○	○	○	×																																		
RP3	○	×	×	○																																		
RP4	×	×	○	○																																		
RP5	×	○	○	○																																		
RP6	○	○	○	○																																		

PCA-RP3GA

OPERATING PROCEDURE	PHOTOS&ILLUSTRATIONS
<p><b>1. Removing the air intake grille</b></p> <ol style="list-style-type: none"> <li>(1) Slide the intake grille holding knobs (at two locations) backward to open the intake grill.</li> <li>(2) When the intake grille left open, push the stoppers on the rear hinges (at two locations) to pull out the intake grille.</li> </ol>	<p><b>Figure 1</b></p> <p>Intake grill Intake grill Holding knobs</p> <p>Hinges Pull out the intake grill</p>
<p><b>2. Removing the electrical box</b></p> <ol style="list-style-type: none"> <li>(1) Remove the air intake grille.</li> <li>(2) Remove the screw from the beam and remove the beam.</li> <li>(3) Remove the screws from the electrical cover, and remove the electrical cover.</li> <li>(4) Disconnect CN6V and CN21.</li> <li>(5) Remove the screws from the electrical box and pull out the electrical box.</li> </ol> <p>&lt;Electrical parts in the electrical box&gt; Terminal block (for indoor / outdoor connecting line) Terminal block (for remote controller) Fan motor capacitor Indoor control board</p>	<p><b>Figure 2</b></p> <p>Beam Slide to the left Screw(electrical cover) Clamp Electrical cover Screw(electrical box)</p> <p><b>Photo 1</b></p> <p>Fan motor capacitor Power board Indoor control board Terminal block (Indoor / outdoor connecting line) Terminal block (remote control)</p>



**OPERATING PROCEDURE**

**3. Removing the fan motor**

- (1) Remove the intake grille.
- (2) Disconnect the fan motor connector.
- (3) Unscrew screws for removing the motor guard.
- (4) Unscrew screws for removing the fan guard.
- (5) Remove the screw for removing the motor support at both left and right side.
- (6) Loosen the set screws at the fan motor side of the connecting joint.
- (7) Slide the fan motor to the left side and pull it out.

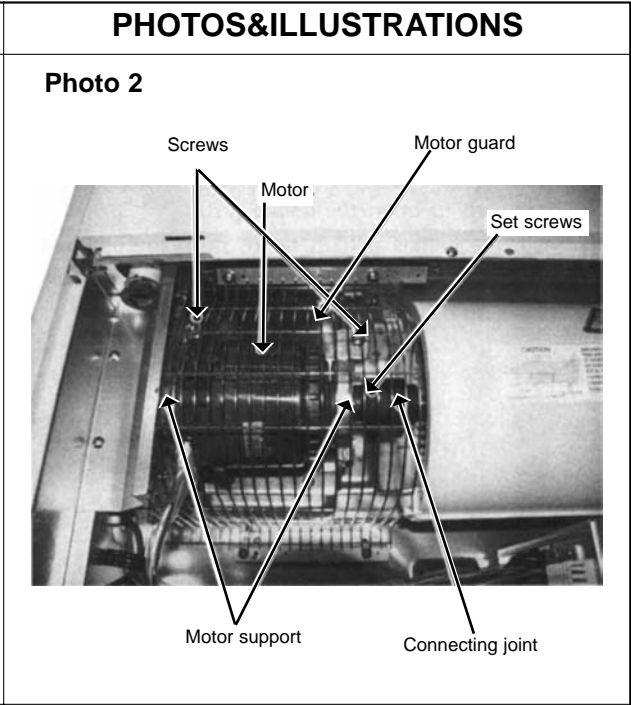

**4. Removing the sirocco fan**

- (1) Remove the air intake grille.
- (2) Remove 1 beam.
- (3) Unscrew screws for removing the motor guard.
- (4) Unscrew screws for removing the fan guard.
- (5) Remove the lower casing while pressing the stoppers at upper side of the casing.
- (6) Loosen the set screws at the connecting joint.
- (7) Remove the sirocco fan and shaft together by sliding the shaft to the left.

(Note)  
Make sure that the upper side casing is snapped to the fan plate securely with catch.

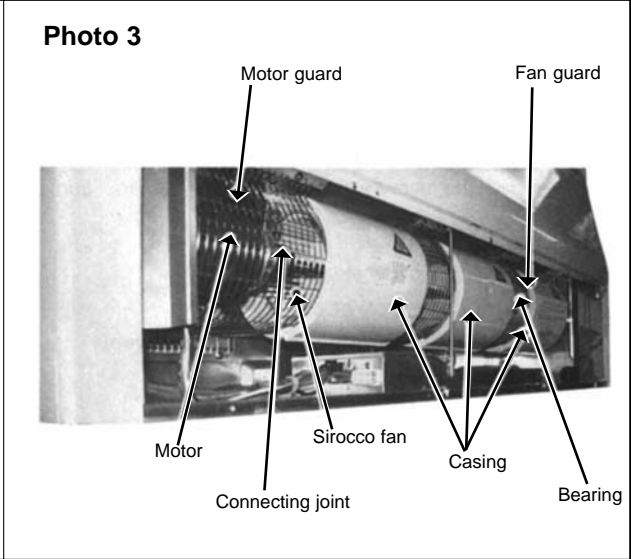

**5. Removing the side panel**

- (1) Remove the air intake grille.
- (2) Remove the screw from the side panel, and remove the side panel by sliding the panel to the front.

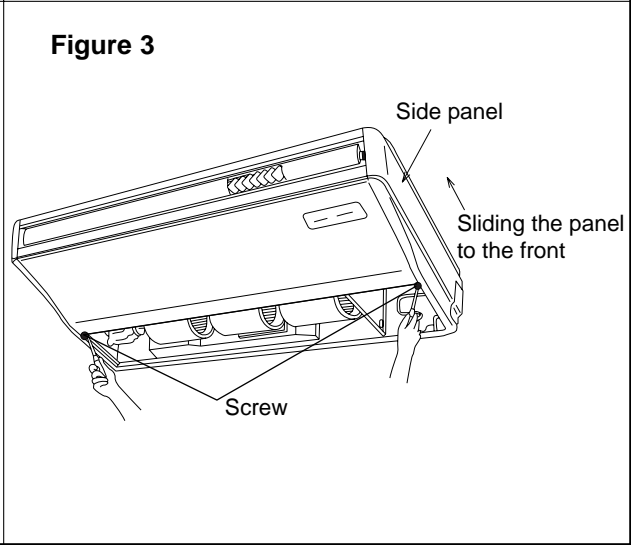

## OPERATING PROCEDURE

### 6. Removing the vane motor

- (1) Remove the air intake grille.
- (2) Remove the left side panel.
- (3) Remove the relay connector of vane motor.
- (4) Remove the electrical box.
- (5) Remove the screws of vane motor, then remove vane motor.

(Note)

Connect the lead wires and connectors properly and place them in the proper position so that the wires are not pinched by other parts.

### 7. Removing the Indoor coil thermistor

- (1) Remove the air intake grille.
- (2) Remove the right side panel.
- (3) Remove the relay connector of the pipe thermistor.
- (4) Remove the screw, and remove the check panel.
- (5) Extract the indoor coil thermistor from the holder.

<Caution for the installation>

There is a possibility for the short circuit when connector gets wet by water through the thermistor lead wire.

Therefore, lead wire of the indoor coil thermistor should be tied as shown in the photo 5.

### 8. Removing the Under panel

- (1) Remove the air intake grille.
- (2) Remove the beam.
- (3) Remove the side panel (right and left).
- (4) Unscrew the screws of the under panel, then remove the under panel.

※ Weight of the under panel : approx. 2kg.

## PHOTOS

Photo 4

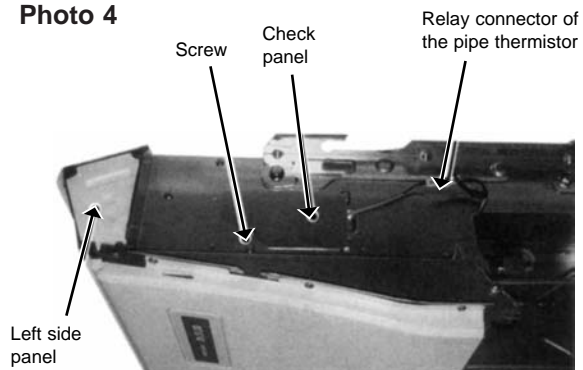

Photo 5

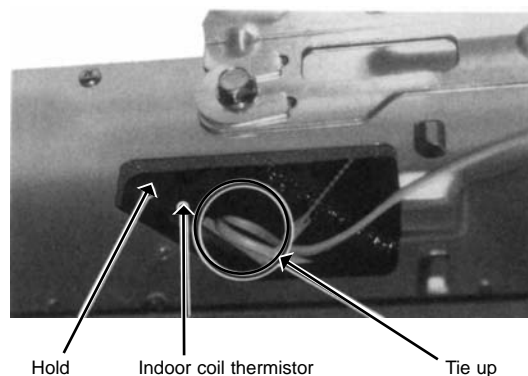

Photo 6

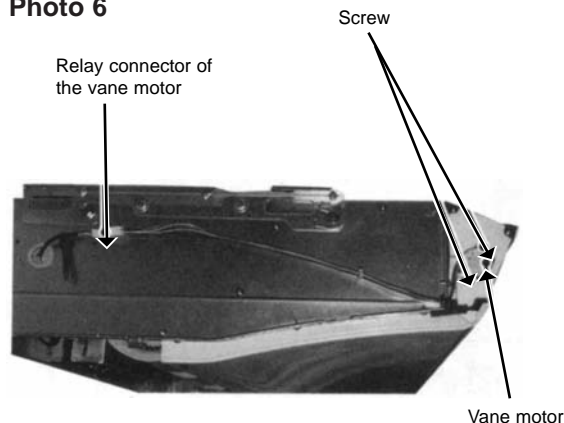
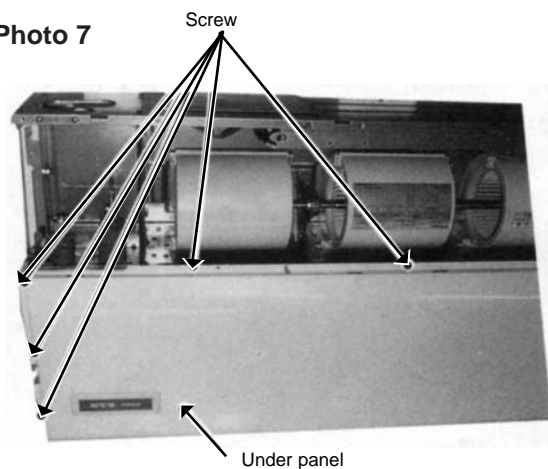

Photo 7





**OPERATING PROCEDURE**

**PHOTOS**

- 9. Removing the drain pan**
- (1) Remove the air intake grille.
  - (2) Remove the beam.
  - (3) Remove the side panel (right and left).
  - (4) Remove the under panel. Remove the screws of the right and left side drain pan.
  - (5) Remove the insulation in centre of the drain pan, and after removing the screw, remove the drain pan.

(Note)  
Please aware that there might be drain left in the drain pan when you remove the drain pump (option).

**Photo 8**

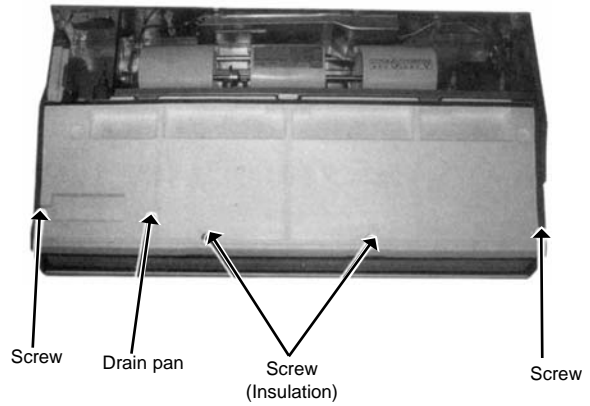

- 10. Removing the guide vane**
- (1) Remove the intake grille.
  - (2) Remove the beam.
  - (3) Remove the side panel (right and left).
  - (4) Remove the under panel.
  - (5) Remove the drain pan.
  - (6) Remove the screw from the guide vane, then remove the guide vane.

**Photo 9**

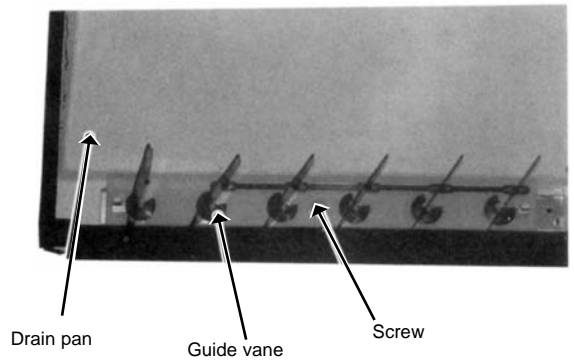

- 11. Removing the Auto vane**
- (1) Remove the intake grille.
  - (2) Remove the left side panel.
  - (3) Remove the left side box.
  - (4) Remove the under panel.
  - (5) Remove the screw from the auto vane.
  - (6) Slide the auto vane to the right side and pull the auto vane out.

**Photo 10**

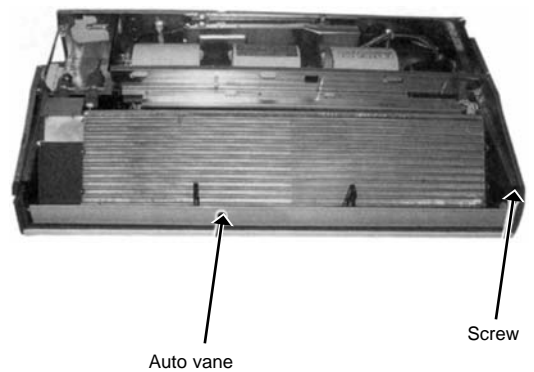

## OPERATING PROCEDURE

### 12. Removing the heat exchanger.

- (1) Remove the air intake grille.
- (2) Remove the beam.
- (3) Remove the side panel (right and left).
- (4) Disconnect the relay connector.
- (5) Remove the under panel.
- (6) Remove the drain pan.
- (7) Unscrew the screw of the pipe cover, and remove the pipe cover.
- (8) Unscrew the screw of the pipe support, and remove the pipe support.
- (9) Unscrew the screw of the heat exchanger, and remove the heat exchanger.

Remove the heat exchanger with care. Since this is quite heavy, removing work should be done with more than 2 people.

\*Weight of heat exchanger : approx. 5.3kg

## PHOTOS

Photo 11

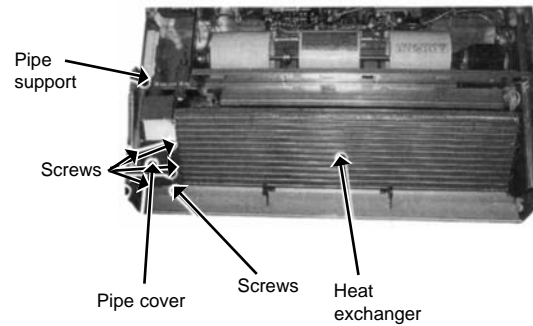

## ELECTRICAL PARTS

PCA-RP2GA

PCA-RP2.5GA

PCA-RP3GA

PCA-RP4GA

PCA-RP5GA

PCA-RP6GA

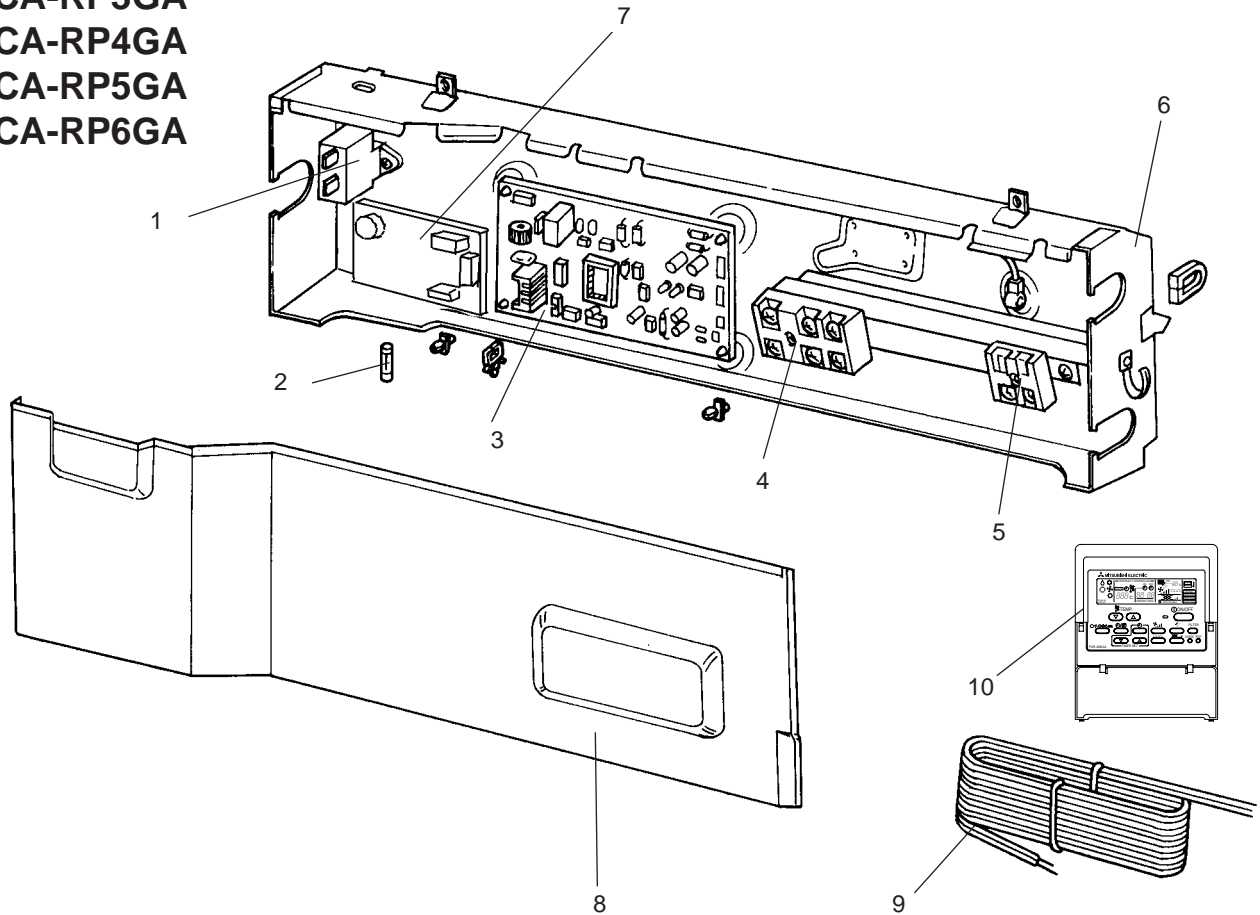

No.	Parts No.	Parts Name	Specifications	Q,ty/set				Remarks (Drawing No.)	Wiring Diagram Symbol	Recom- mended Q'ty	Price	
				PCA-RP							Unit	Amount
				2GA	2.5GA 3GA	4GA	5GA 6GA					
1	R01 30L 255	CAPACITOR	3 $\mu$ F 440V	1					C1			
	T7W 39J 255	CAPACITOR	4 $\mu$ F 440V		1	1			C1			
	R01 A13 255	CAPACITOR	6 $\mu$ F 440V				1		C1			
2	R01 E00 239	FUSE	250V 4A	1	1	1	1					
3	T7W E36 310	INDOOR CONTROLLER BOARD		1	1	1	1		I.B			
4	T7W E13 716	TERMINAL BLOCK	3P(S1,S2,S3)	1	1	1	1		TB4			
5	T7W 512 716	TERMINAL BLOCK	2P(1,2)	1	1	1	1		TB5			
6	—	CONTROL BOX		1	1	1	1	(BG00N015G25)				
8	—	CONTROL COVER		1				(BG02A804G20)				
	—	CONTROL COVER			1		1	(BG02A804G21)				
	—	CONTROL COVER				1		(BG02A804G22)				
9	T7W A00 305	REMOTE CONTROLLER CORD		1	1	1	1					
10	T7W E06 713	REMOTE CONTROLLER	PAR-20MAA	1	1	1	1					

# STRUCTURAL PART PCA-RP2GA

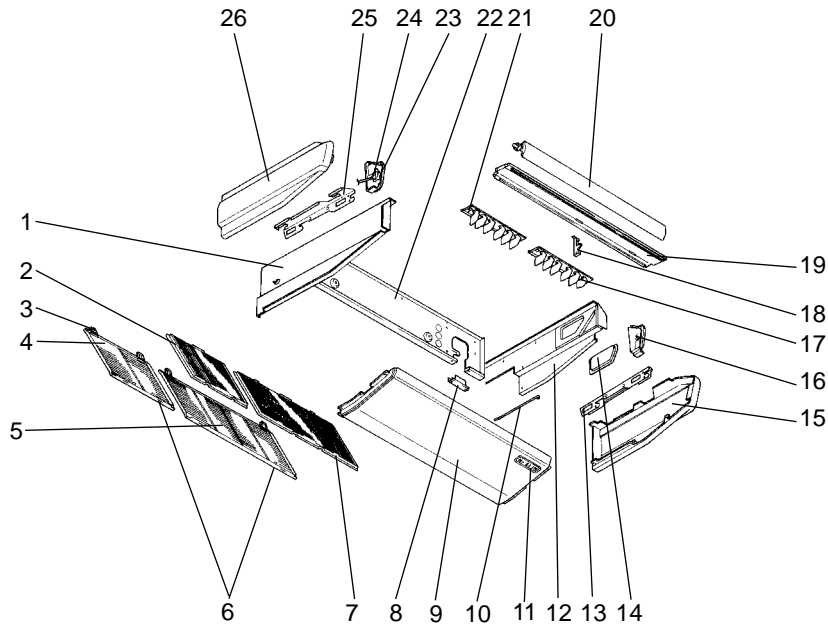

Part number that is circled is not shown in the figure.

No.	Parts No.	Parts Name	Specifications	Q'ty/set	Remarks (Drawing No.)	Wiring Diagram Symbol	Recom- mended Q'ty	Price	
				PCA-RP2GA				Unit	Amount
1	R01 57N 666	S.PLATE-L		1					
2	R01 A15 500	L.L FILTER		1					
3	R01 17J 061	GRILLE HINGE		4					
4	R01 18J 691	GRILLE ASSY		1					
5	R01 17J 691	GRILLE ASSY		1					
6	R01 17J 054	GRILLE CATCH		4					
7	R01 A14 500	L.L FILTER		1					
8	—	REAR SUPPORT		1	(BG02H454K01)				
9	R01 17J 669	UNDER PANEL		1					
10	—	BEAM(GA)		2	(BG17H464H08)				
11	T7W E01 070	W.BOARD CASE		1					
12	R01 18J 665	S.PLATE-R		1					
13	R01 17J 808	RIGHT LEG (R)		1					
14	R01 17J 668	SERVICE PANEL		1					
15	R01 17J 661	RIGHT SIDE PANEL		1					
16	R01 17J 067	RIGHT SIDE BOX		1					
17	R01 37J 085	G.V ASSY-6R		1					
18	R01 E00 033	VANE SUPPORT		1					
19	R01 17J 651	FRONT PANEL		1					
20	R01 17J 002	AUTO VANE		1					
21	R01 37J 086	G.V ASSY-6L		1					
22	R01 A14 676	REAR PANEL		1					
23	R01 17J 068	LEFT SIDE BOX		1					
24	R01 E03 223	VANE MOTOR		1		MV			
25	R01 17J 809	LEFT LEG (L)		1					
26	R01 17J 662	LEFT SIDE PANEL		1					
27	R01 17J 523	JOINT SOCKET		1					



**STRUCTURAL PART**  
**PCA-RP2.5GA**  
**PCA-RP3GA**  
**PCA-RP4GA**

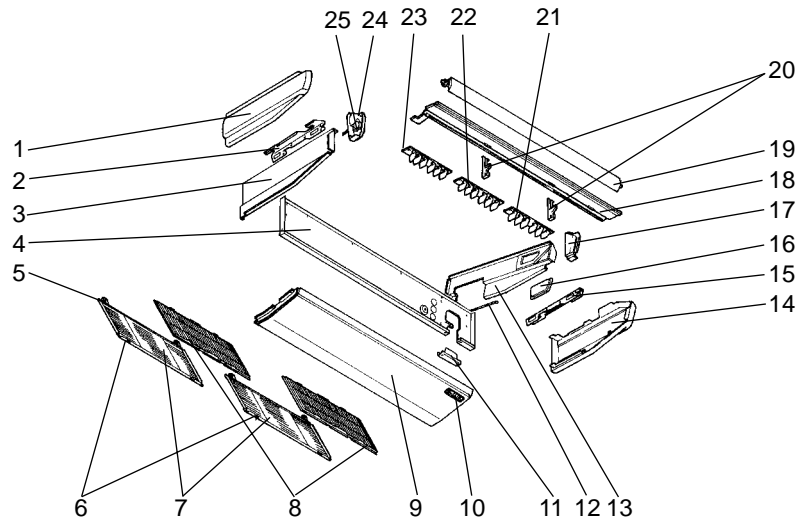

Part number that is circled is not show in the figure.

No.	Parts No.	Parts Name	Specifications	Q'ty/set		Remarks (Drawing No.)	Wiring Diagram Symbol	Recom- mended Q'ty	Price	
				PCA-RP					Unit	Amount
				2.5GA 3GA	4GA					
1	R01 17J 662	LEFT SIDE PANEL		1						
	R01 35J 662	LEFT SIDE PANEL			1					
2	R01 17J 809	LEFT LEG		1	1					
3	R01 57N 666	S.PLATE-L		1						
	R01 35J 666	S.PLATE-L			1					
4	R01 A15 676	REAR PANEL		1						
	R01 A16 676	REAR PANEL			1					
5	R01 17J 061	GRILLE HINGE		4	4					
6	R01 17J 054	GRILLE CATCH		4	4					
7	R01 17J 691	GRILLE ASSY		2	2					
8	R01 A14 500	L.L FILTER		2	2					
9	R01 29J 669	UNDER PANEL		1	1					
10	T7W E01 070	W.BOARD CASE		1	1					
11	—	REAR SUPPORT		1	1	(BG02H454K01)				
12	—	BEAM (GA)		2	2	(BG17H464H08)				
13	R01 18J 665	S.PLATE-R		1						
	R01 E00 665	S.PLATE-R			1					
14	R01 17J 661	RIGHT SIDE PANEL		1						
	R01 35J 661	RIGHT SIDE PANEL			1					
15	R01 17J 808	RIGHT LEG		1	1					
16	R01 17J 668	SERVICE PANEL		1						
	R01 18J 668	SERVICE PANEL			1					
17	R01 17J 067	RIGHT SIDE BOX		1						
	R01 35J 067	RIGHT SIDE BOX			1					
18	R01 29J 651	FRONT PANEL		1						
	R01 36J 651	FRONT PANEL			1					
19	R01 29J 002	AUTO VANE		1						
	R01 E03 002	AUTO VANE			1					
20	R01 E00 033	VANE SUPPORT		2						
	R01 E01 033	VANE SUPPORT			2					
21	R01 37J 085	G.V ASSY-6R		1	1					
22	R01 37J 087	G.V ASSY-6C		1	1					
23	R01 37J 086	G.V ASSY-6L		1	1					
24	R01 17J 068	LEFT SIDE BOX		1						
	R01 E00 068	LEFT SIDE BOX			1					
25	R01 29J 223	VANE MOTOR		1			MV			
	R01 35J 223	VANE MOTOR			1		MV			
26	R01 17J 523	JOINT SOCKET		1	1					

**STRUCTURAL PART**  
**PCA-RP5GA**  
**PCA-RP6GA**

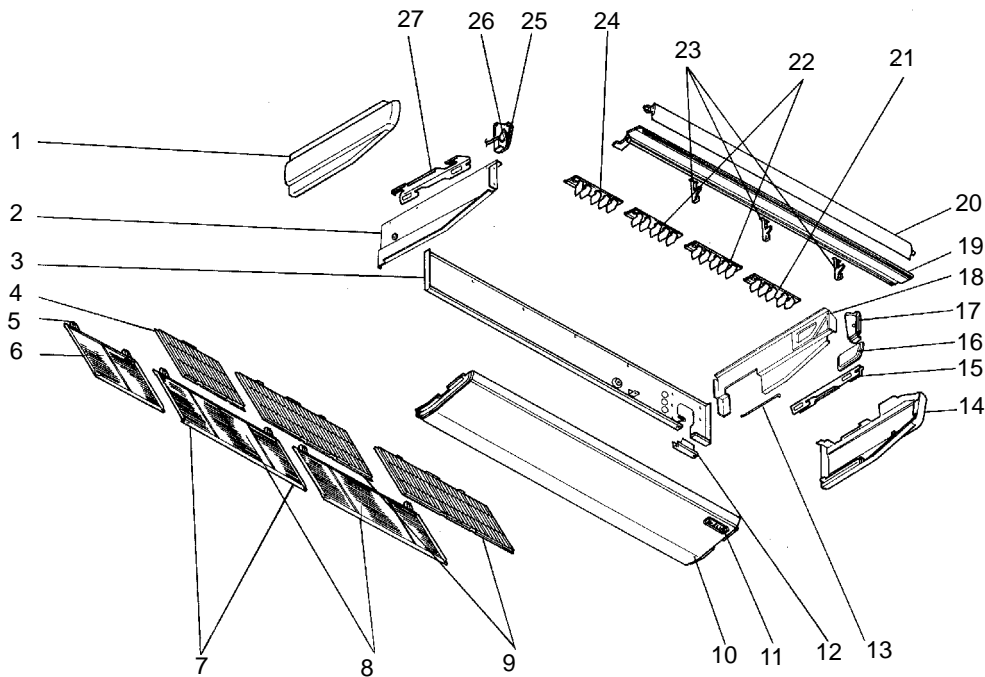

Part number that is circled is not shown in the figure.

No.	Parts No.	Parts Name	Specifications	Q'ty/set		Remarks (Drawing No.)	Wiring Diagram Symbol	Recom- mended Q'ty	Price	
				PCA-RP5GA	PCA-RP6GA				Unit	Amount
1	R01 35J 662	LEFT SIDE PANEL		1						
2	R01 35J 666	S.PLATE-L		1						
3	R01 A17 676	REAR PANEL		1						
4	R01 A15 500	L.L FILTER		1						
5	R01 17J 061	GRILLE HINGE		6						
6	R01 18J 691	GRILLE ASSY		1						
7	R01 17J 054	GRILLE CATCH		6						
8	R01 17J 691	GRILLE ASSY		2						
9	R01 A14 500	L.L FILTER		2						
10	R01 41J 669	UNDER PANEL		1						
11	T7W E01 070	W.BOARD CASE		1						
12	—	REAR SUPPORT		1	(BG02H454K01)					
13	—	BEAM(GA)		3	(BG17H464H08)					
14	R01 35J 661	RIGHT SIDE PANEL		1						
15	R01 17J 808	RIGHT LEG		1						
16	R01 18J 668	SERVICE PANEL		1						
17	R01 35J 067	RIGHT SIDE BOX		1						
18	R01 E00 665	S.PLATE-R		1						
19	R01 41J 651	FRONT PANEL		1						
20	R01 E04 002	AUTO VANE		1						
21	R01 41J 085	G.V ASSY-5R		1						
22	R01 43J 087	G.V ASSY-5C		2						
23	R01 E01 033	VANE SUPPORT		3						
24	R01 42J 086	G.V ASSY-5L		1						
25	R01 E00 068	LEFT SIDE BOX		1						
26	R01 35J 223	VANE MOTOR		1			MV			
27	R01 17J 809	LEFT LEG		1						
28	R01 17J 523	JOINT SOCKET		1						

# FAN AND HEATER PARTS PCA-RP2GA

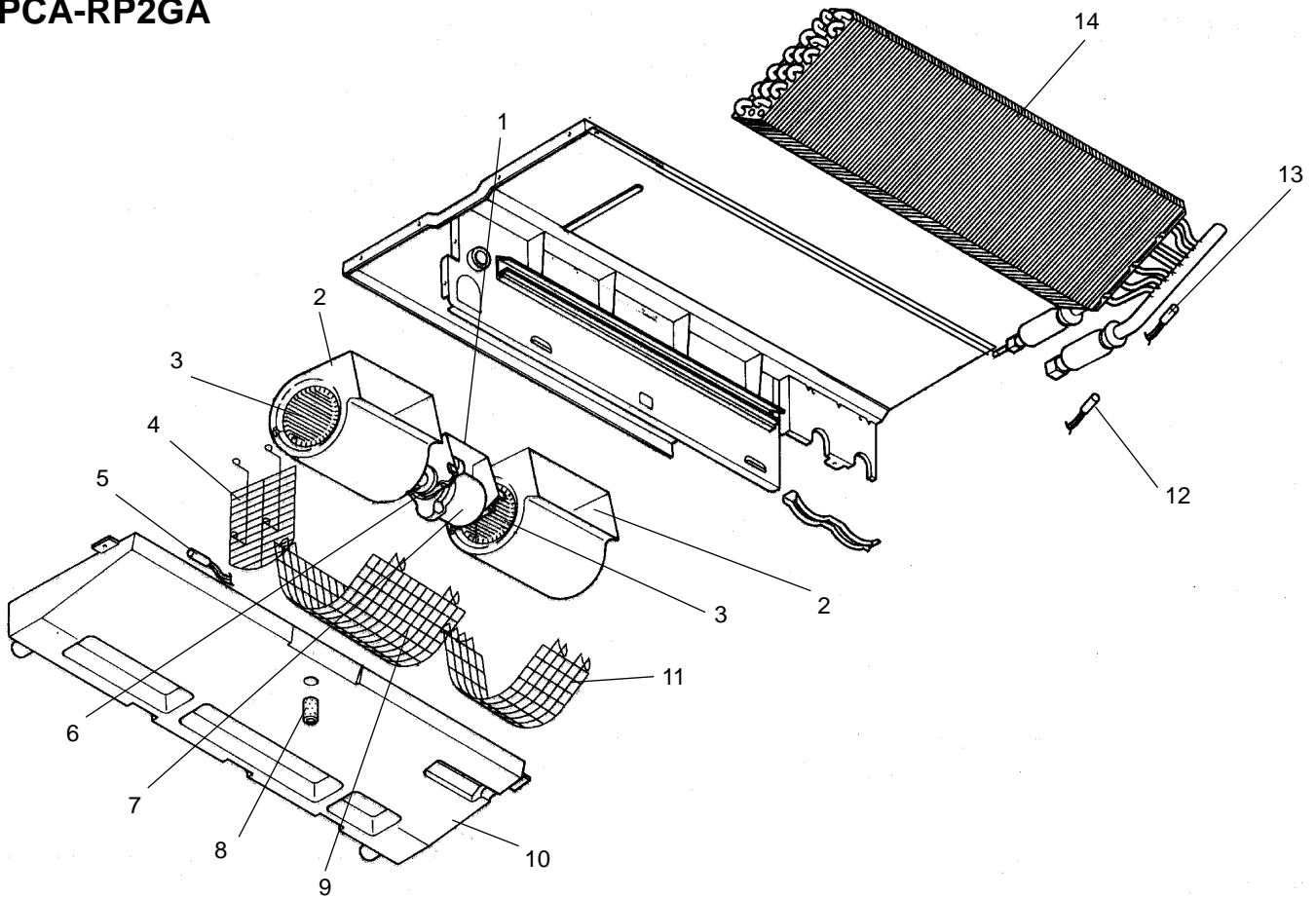

Part number that is circled is not shown in the figure.

No.	Parts No.	Parts Name	Specifications	Q'ty/set	Remarks (Drawing No.)	Wiring Diagram Symbol	Recom- mended Q'ty	Price	
				PCA-RP2GA				Unit	Amount
1	R01 17J 130	MOTOR LEG		1					
2	T7W B06 110	CASING		2					
3	R01 17J 114	SIROCCO FAN		2					
4	T7W 19J 675	FAN GUARD		1					
5	R01 E26 202	ROOM TEMPERATURE THERMISTOR		1		TH1			
6	R01 43E 126	PIECE (MOTOR)	2pcs/set	1					
7	T7W 23J 762	FAN MOTOR	D09B4P54MS	1		MF			
8	R01 17J 524	DRAIN PLUG		1					
9	T7W 17J 675	FAN GUARD		1					
10	R01 A14 529	DRAIN PAN ASSY		1					
11	T7W 18J 675	FAN GUARD		1					
12	R01 17J 202	LIQUID PIPE TEMPERATURE THERMISTOR		1		TH2			
13	T7W E08 202	CONDENSER / EVAPORTOR TEMPERATURE THERMISTOR		1		TH5			
14	T7W E51 480	HEAT EXCHANGER		1					
15	T7W E00 072	DRAIN HOSE COVER		1					

**FAN AND HEATER PARTS**  
**PCA-RP2.5GA**  
**PCA-RP3GA**  
**PCA-RP4GA**

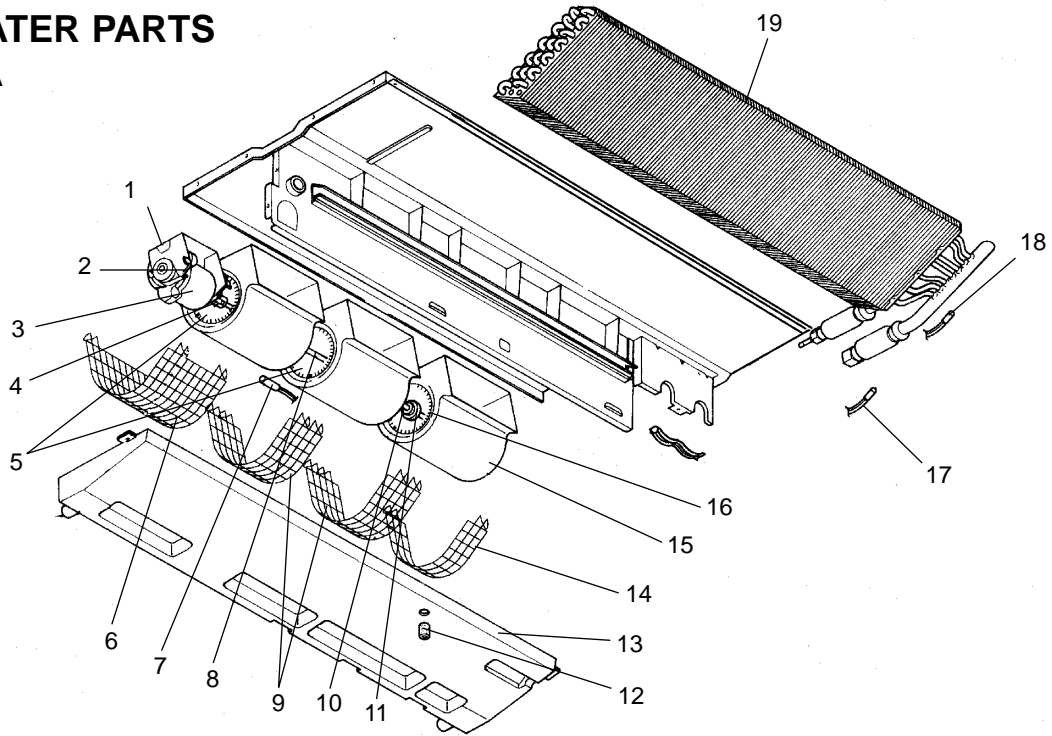

Part number that is circled is not shown in the figure.

No.	Parts No.	Parts Name	Specifications	Q'ty/set		Remarks (Drawing No.)	Wiring Diagram Symbol	Recom- mended Q'ty	Price	
				PCA-RP					Unit	Amount
				2.5GA 3GA	4GA					
1	R01 29J 130	MOTOR LEG		1						
	R01 35J 130	MOTOR LEG			1					
2	R01 43E 126	PIECE(MOTOR)	2pcs/set	1	1					
3	T7W 30J 762	FAN MOTOR	D09C4P70MS	1			MF			
	T7W 39J 762	FAN MOTOR	D10B4P90MS		1		MF			
4	R01 700 116	FAN JOINT		1	1					
5	R01 29J 114	SIROCCO FAN		2						
	R01 35J 114	SIROCCO FAN			2					
6	T7W 20J 675	FAN GUARD		1						
	T7W 22J 675	FAN GUARD			1					
7	R01 E26 202	ROOM TEMPERATURE THERMISTOR		1	1		TH1			
8	R01 29J 100	SHAFT		1	1					
9	T7W 21J 675	FAN GUARD		2						
	T7W 23J 675	FAN GUARD			2					
10	R01 E00 103	SLEEVE BEARING		1	1					
11	R01 29J 145	BEARING SUPPORT		1						
	R01 35J 145	BEARING SUPPORT			1					
12	R01 17J 524	DRAIN PLUG		1	1					
13	R01 A15 529	DRAIN PAN ASSY		1						
	R01 A16 529	DRAIN PAN ASSY			1					
14	T7W 18J 675	FAN GUARD		1						
	T7W 24J 675	FAN GUARD			1					
15	T7W B06 110	CASING		3						
	T7W B07 110	CASING			3					
16	R01 33J 114	SIROCCO FAN		1						
	R01 41J 114	SIROCCO FAN			1					
17	R01 17J 202	LIQUID PIPE TEMPERATURE THERMISTOR		1	1		TH2			
18	T7W E08 202	CONDENSER / EVAPORTOR TEMPERATURE THERMISTOR		1	1		TH5			
19	R01 H00 480	HEAT EXCHANGER		1						
	T7W E52 480	HEAT EXCHANGER			1					
20	T7W E00 072	DRAIN HOSE COVER		1	1					

# FAN AND HEATER PARTS

## PCA-RP5GA

## PCA-RP6GA

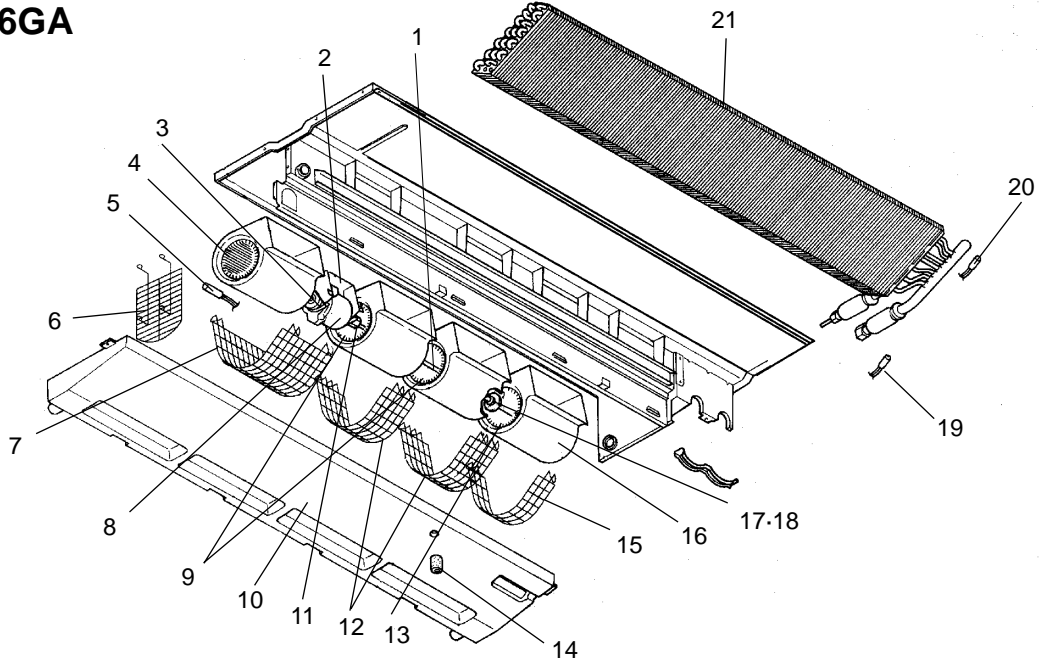

Part number that is circled is not shown in the figure.

No.	Parts No.	Parts Name	Specifications	Q'ty/set		Remarks (Drawing No.)	Wiring Diagram Symbol	Recom- mended Q'ty	Price	
				PCA-RP					Unit	Amount
				5GA	6GA					
1	R01 29J 100	SHAFT		1	1					
2	R01 41J 130	MOTOR LEG		1	1					
3	R01 43E 126	PIECE (MOTOR)	2pcs/set	1	1					
4	R01 41J 114	SIROCCO FAN		1	1					
5	R01 E26 202	ROOM TEMPERATURE THERMISTOR		1	1		TH1			
6	T7W 26J 675	FAN GUARD		1	1					
7	T7W 25J 675	FAN GUARD		1	1					
8	T7W 43J 762	FAN MOTOR	D10B4P150MS	1	1		MF			
9	R01 35J 114	SIROCCO FAN		2	2					
10	R01 A17 529	DRAIN PAN ASSY		1	1					
11	R01 700 116	FAN JOINT		1	1					
12	T7W 23J 675	FAN GUARD		2	2					
13	R01 39J 114	SIROCCO FAN		1	1					
14	R01 17J 524	DRAIN PLUG		1	1					
15	T7W 24J 675	FAN GUARD		1	1					
16	T7W B07 110	CASING		4	4					
17	R01 E00 103	SLEEVE BEARING		1	1					
18	R01 35J 145	BEARING SUPPORT		1	1					
19	R01 17J 202	LIQUID PIPE TEMPERATURE THERMISTOR		1	1		TH2			
20	T7W E08 202	CONDENSER / EVAPORTOR TEMPERATURE THERMISTOR		1	1		TH5			
21	T7W E53 480	HEAT EXCHANGER		1						
	T7W E54 480	HEAT EXCHANGER			1					
(22)	T7W E00 072	DRAIN HOSE COVER		1	1					

12-1. TIMER

Part No.	PAC-SC32PTA (with set back function)
Model Name	Program timer

12-1-1. Program timer specifications

Part name	Program timer
Parts No.	PAC-SC32PTA
Exterior dimensions (inch)	5-4/32X4-23/32X23/32 (130X120X18mm)
Installation	Wall mount
Type of clock	Quartz
Clock accuracy	±50 second / month at 25°C
Display-Time	Liquid crystal display
-Week	Liquid crystal display
-Timer setting unit	Liquid crystal display
Program cycle	24 hours
Timer setting unit	30 minutes
No. of set points	48 / day
Power rating	5V DC ±5% (Supplied by Remote Controller)

12-1-2. Feature of program timer

- (1) Daily timer function  
Daily timer can be set in 30 minutes units for up to 24 hours.  
Each unit can be set for unit ON, unit OFF, or setback operation.
- (2) Setback operation  
Set back operation is useful for reducing running costs  
e.g. At a hotel with a 24-hour system  
8:00~23:00 Cooling operation with set temperature at 26°C  
23:00~8:00 Setback operation with 2 degrees of setback  
As shown in the chart on the right, the set temperature rises 2 degrees automatically during the setback operation. When the setback operation ends, normal operation will begin.
- (3) Weekly timer function  
Daily timer function can apply to each day of the week.

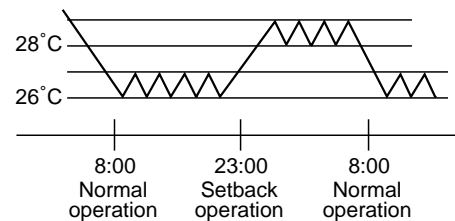

### 12-1-3. How to connect program timer

- (1) Install the program timer next to the remote controller the same way as the remote controller is installed.
- (2) Connect the program timer and the remote controller with a 5-wire cable as shown in the figure below

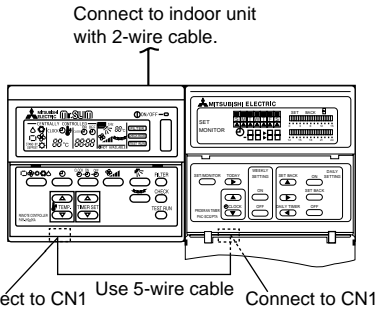

NOTE: While the program timer is connected to the remote controller, the 24hour ON/OFF timer on the remote controller will not operate.

### 12-1-4. Names and functions

<PAC-SC32PTA>

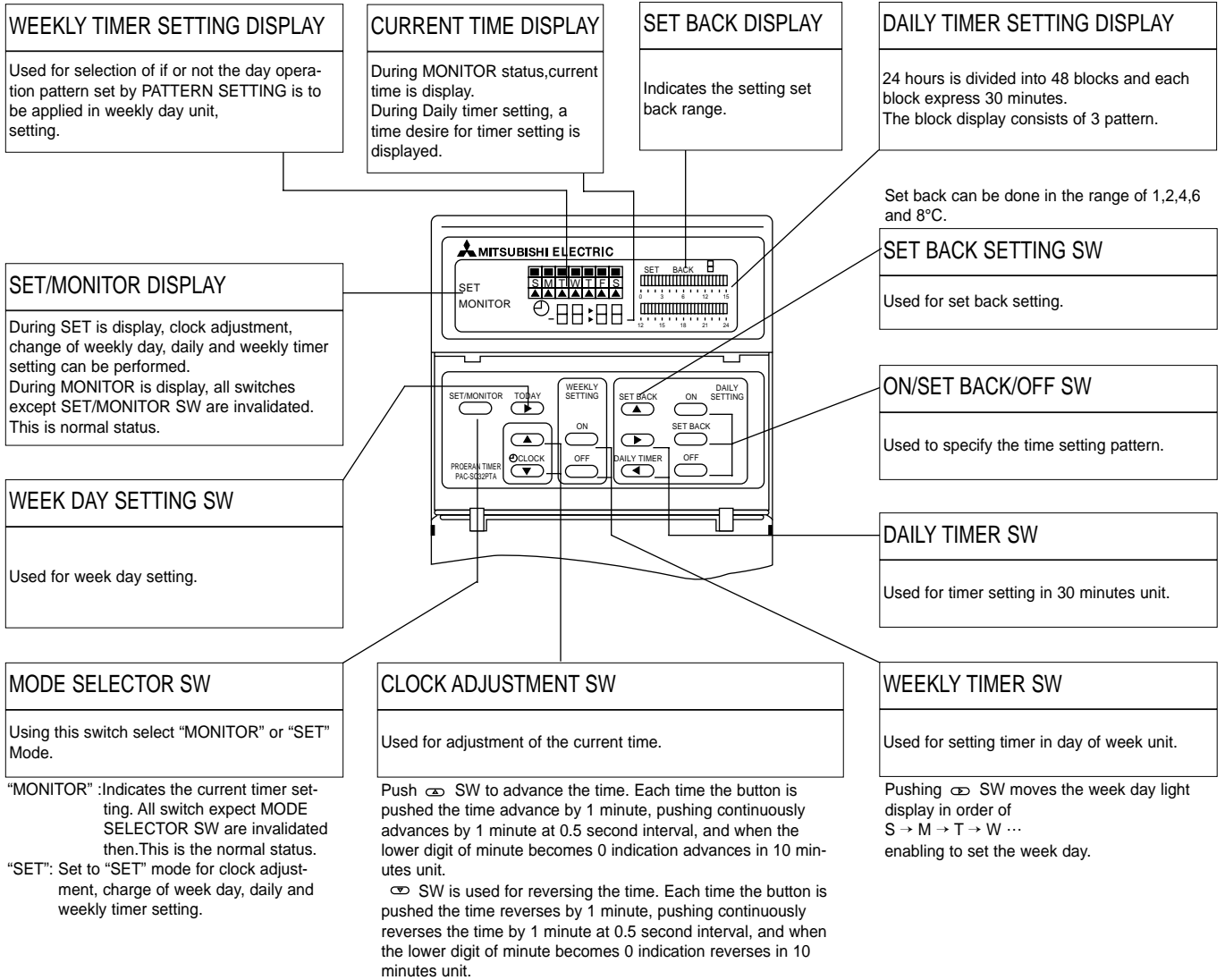

## 12-2. Drain Lift Up Mechanism

Part No.	PAC-SE85DMA-E	PAC-SE86DMA-E
Applied Service Ref.	PCA-RP2, 2.5, 3GA	PCA-RP4, 5 ,6GA

## 12-3. High-Efficiency Filter

Part No.	PAC-SE80KF-E	PAC-SE81KF-E	PAC-SE82KF-E
Applied Service Ref.	PCA-RP2GA	PCA-RP2.5, 3, 4GA	PCA-RP5, 6GA

## 12-4. Wireless Remote Controller + Wireless Adapter

Part No.	PAR-SL99A-E
Applied Service Ref.	PCA-RP2, 2.5, 3, 4, 5, 6GA

## 12-5. Remote Sensor

Part No.	PAC-SE41TS-E
Applied Service Ref.	PCA-RP2, 2.5, 3, 4, 5, 6GA

## 12-6. Remote Operation Adapter

Part No.	PAC-SF40RM-E
Applied Service Ref.	PCA-RP2, 2.5, 3, 4, 5, 6GA

## 12-7. Remote ON/OFF Adapter

Part No.	PAC-SF55RA-E
Applied Service Ref.	PCA-RP2, 2.5, 3, 4, 5, 6GA



HEAD OFFICE : MITSUBISHI DENKI BLDG., 2-2-3, MARUNOUCHI,CHIYODA-KU TOKYO 100-8310, JAPAN