



PEAD-RP100EA2

Standard Inverter Heat Pump

R410A Ceiling Concealed Ducted System

The new Standard Inverter range provides inverter solutions for customers who want all the benefits that inverters offer, but do not have the budget available for the more expensive Power Inverter range.



Pictures not to scale

Product Details

PEAD-RP100EA2 Indoor Unit

Capacity (kW):	
Heating (Nominal) (Low - High)	11.20 (4.50 - 12.50)
Cooling (Nominal) (Low - High)	9.40 (4.90 - 11.20)
Heating (UK) (Low - High)	9.50 (3.85 - 10.65)
Cooling (UK) (Low - High)	8.45 (4.40 - 10.10)
SHF R410A (Nominal)	0.86
COP / EER (Nominal)	3.41 / 3.01
Energy Label Heating / Cooling	B / B
Width - mm	1415
Depth - mm	740
Height - mm	325
Weight - kg	65
Airflow (m3/min) - Lo-Hi	33.5-42
External Static Pressure Pa - Lo-Hi	70-130
Noise (dBA) - Lo-Hi	44-50
Pipe Size Gas mm (in)	15.88 (5/8)
Pipe Size Liquid mm (in)	9.52 (3/8)
Electrical Supply	Fed by Outdoor Unit
Phase	Single
Fuse Rating (BS88) - HRC (A)	6
Interconnecting Cable No. Cores	4
Remote Controller Ref	PAR-21MAA

PUHZ-P100VHA2 Outdoor Unit

Width - mm	950
Depth - mm	330 + 30
Height - mm	943
Weight - kg	75
Noise (dBA) (Heating /Cooling)	54 /50
Electrical Supply	220-240v, 50Hz
Phase	Single
Fuse Rating (BS88) - HRC (A)	32
SystemPower Input (kW) - Heating (Nominal)	3.28
SystemPower Input (kW) - Cooling (Nominal)	3.12
SystemPower Input (kW) - Heating (UK)	2.92
SystemPower Input (kW) - Cooling (UK)	2.65
Starting Current (A)	4
SystemRunning Current (A) - Heating / Cooling	15.24 / 14.88
Mains Cable No. Cores	3
Max Pipe Length (m)	50
Max Height Difference (m)	30
Charge (kg) - 20m	2.7

Dimensions

PEAD-RP100EA2

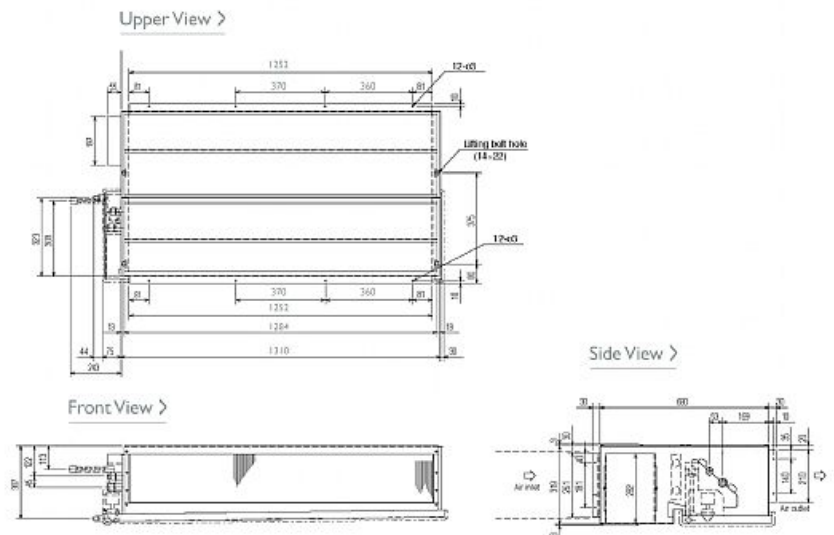

PUHZ-P100VHA2

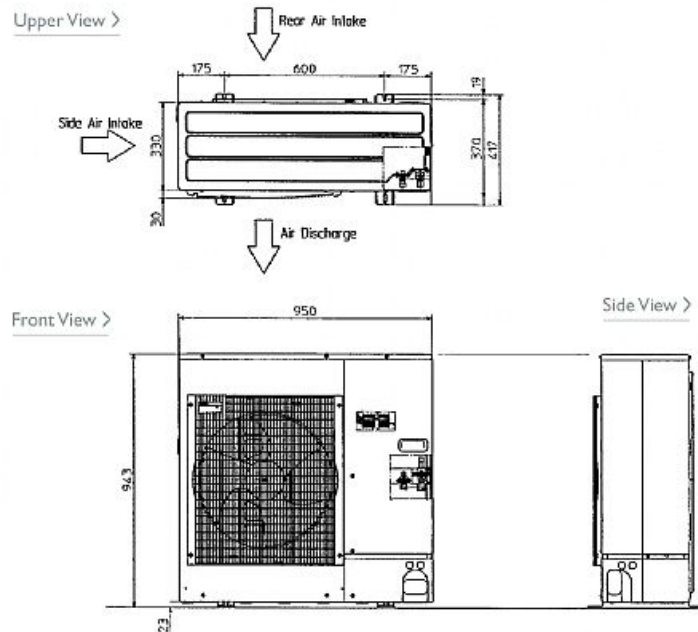

Telephone: 01707 282880

Email: air.conditioning@meuk.mee.com Website: <http://www.mitsubishielectric.co.uk/aircon>

Mitsubishi Electric reserves the right to make any variation in technical specification to the equipment described, or to withdraw or replace products without prior notification or public announcement.

Tel:
Fax:

