

TECHNICAL & SERVICE MANUAL

Series PKA **Wall Mounted** **R407C/R410A**
**Indoor unit
[Model names]**

PKA-RP1.6GAL

PKA-RP2GAL

[Service Ref.]
**PKA-RP1.6GAL
PKA-RP2GAL**

• This manual does not cover outdoor units. When servicing them, please refer to service manual OC261 REVISED EDITION-B, OC285, OC294 REVISED EDITION-A, OC298 and this manual in a set.

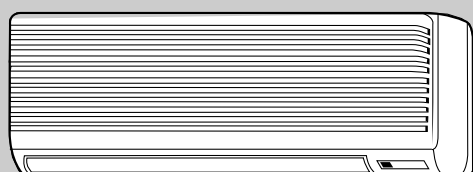

Indoor unit

Model name indication

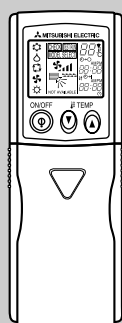

Remote controller

CONTENTS

1. COMBINATION OF INDOOR AND OUTDOOR UNITS	2
2. SAFETY PRECAUTION	3
3. PART NAMES AND FUNCTIONS	6
4. SPECIFICATIONS	8
5. DATA	11
6. OUTLINES AND DIMENSIONS	26
7. WIRING DIAGRAM	27
8. REFRIGERANT SYSTEM DIAGRAM	28
9. TROUBLE SHOOTING	29
10. DISASSEMBLY PROCEDURE	39
11. PARTS LIST	42
12. OPTIONAL PARTS	BACK COVER

1 COMBINATION OF INDOOR AND OUTDOOR UNITS

(R410A Inverter)

Indoor unit	Outdoor unit [OC294 REVISÉD EDITION-A]	
	Heat pump type	
	PUHZ-RP	
	1.6VHA	2VHA
PKA-RP1.6GAL	○	—
PKA-RP2GAL	—	○

(R407C Fixed speed)

	Indoor unit	Outdoor unit [OC285]		Outdoor unit [OC298]	
		Heat pump type		Cooling only type	
		PUH-P		PU-P	
		1.6VGAA	2VGAA	1.6VGAA	2VGAA
Heat pump without electric heater or Cooling only	PKA-RP1.6GAL	○	—	○	—
	PKA-RP2GAL	—	○	—	○

(R407C Fixed speed)

	Indoor unit	Outdoor unit [OC261 REVISÉD EDITION-B]							
		Heat pump type				Cooling only type			
		PUH-P				PU-P			
		1.6		2		1.6		2	
		VGAA.UK	YGAA.UK	VGAA.UK	YGAA.UK	VGAA.UK	YGAA.UK	VGAA.UK	YGAA.UK
		VGAA ₁ .UK	YGAA ₁ .UK	VGAA ₁ .UK	YGAA ₁ .UK	VGAA ₁ .UK	YGAA ₁ .UK	VGAA ₁ .UK	YGAA ₁ .UK
Heat pump without electric heater or Cooling only	PKA-RP1.6GAL	○	○	—	—	○	○	—	—
	PKA-RP2GAL	—	—	○	○	—	—	○	○

CAUTIONS RELATED TO NEW REFRIGERANT

Cautions for units utilizing refrigerant R407C

Do not use the existing refrigerant piping.

The old refrigerant and lubricant in the existing piping contains a large amount of chlorine which may cause the lubricant deterioration of the new unit.

Use "low residual oil piping"

If there is a large amount of residual oil (hydraulic oil, etc.) inside the piping and joints, deterioration of the lubricant will result.

Store the piping to be used during installation indoors with keep both ends sealed until just before brazing. (Store elbows and other joints in a plastic bag.)

If dust, dirt, or water enters the refrigerant cycle, deterioration of the oil and compressor trouble may result.

Use ESTR , ETHER or HAB as the lubricant to coat flares and flange connection parts.

If large amount of mineral oil enter, that can cause deterioration of refrigerant oil etc.

Use liquid refrigerant to seal the system.

If gas refrigerant is used to seal the system, the composition of the refrigerant in the cylinder will change and performance may drop.

Do not use a refrigerant other than R407C.

If another refrigerant (R22, etc.) is used, the chlorine in the refrigerant may cause the lubricant deterioration.

Use a vacuum pump with a reverse flow check valve.

The vacuum pump oil may flow back into the refrigerant cycle and cause the lubricant deterioration.

Ventilate the room if refrigerant leaks during operation. If refrigerant comes into contact with a flame, poisonous gases will be released.**[1] Cautions for service**

- After recovering the all refrigerant in the unit, proceed to working.
- Do not release refrigerant in the air.
- After completing the repair service, recharge the cycle with the specified amount of liquid refrigerant.

[2] Refrigerant recharging

(1) Refrigerant recharging process

①Direct charging from the cylinder.

- R407C cylinder are available on the market has a syphon pipe.
 - Leave the syphon pipe cylinder standing and recharge it.
- (By liquid refrigerant)

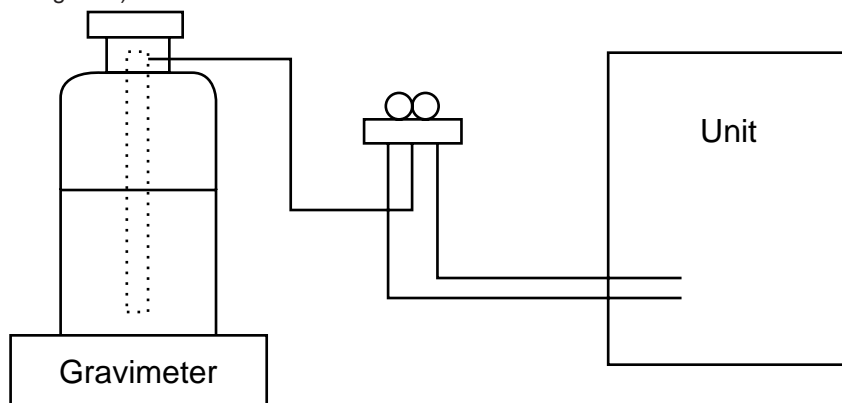

(2) Recharge in refrigerant leakage case

- After recovering the all refrigerant in the unit, proceed to working.
- Do not release the refrigerant in the air.
- After completing the repair service, recharge the cycle with the specified amount of liquid refrigerant.

[3] Service tools

Use the below service tools as exclusive tools for R407C refrigerant.

No.	Tool name	Specifications
①	Gauge manifold	·Only for R407C.
		·Use the existing fitting SPECIFICATIONS. (UNF7/16)
		·Use high-tension side pressure of 3.43MPa-G or over.
②	Charge hose	·Only for R407C.
		·Use pressure performance of 5.10MPa-G or over.
③	Electronic scale	
④	Gas leak detector	·Use the detector for R134a or R407C.
⑤	Adapter for reverse flow check.	·Attach on vacuum pump.
⑥	Refrigerant charge base.	
⑦	Refrigerant cylinder.	·For R407C ·Top of cylinder (Brown)
		·Cylinder with syphon
⑧	Refrigerant recovery equipment.	

CAUTIONS RELATED TO NEW REFRIGERANT

Cautions for units utilizing refrigerant R410A

Use new refrigerant pipes.

In case of using the existing pipes for R22, be careful with the followings.

- Change flare nut to the one provided with this product.
Use a newly flared pipe.
- Avoid using thin pipes.

Make sure that the inside and outside of refrigerant piping is clean and it has no contamination such as sulfur hazardous for use, oxides, dirt, shaving particles, etc. In addition, use pipes with specified thickness.

Contamination inside refrigerant piping can cause deterioration of refrigerant oil etc.

Store the piping to be used during installation indoors and keep both ends of the piping sealed until just before brazing. (Leave elbow joints, etc. in their packaging.)

If dirt, dust or moisture enter into refrigerant cycle, that can cause deterioration of refrigerant oil or malfunction of compressor.

Use ester oil, ether oil or alkylbenzene oil (small amount) as the refrigerant oil applied to flares and flange connections.

If large amount of mineral oil enter, that can cause deterioration of refrigerant oil etc.

Charge refrigerant from liquid phase of gas cylinder.

If the refrigerant is charged from gas phase, composition change may occur in refrigerant and the efficiency will be lowered.

Do not use refrigerant other than R410A.

If other refrigerant (R22 etc.) is used, chlorine in refrigerant can cause deterioration of refrigerant oil etc.

Use a vacuum pump with a reverse flow check valve.

Vacuum pump oil may flow back into refrigerant cycle and that can cause deterioration of refrigerant oil etc.

Use the following tools specifically designed for use with R410A refrigerant.

The following tools are necessary to use R410A refrigerant.

Tools for R410A	
Gauge manifold	Flare tool
Charge hose	Size adjustment gauge
Gas leak detector	Vacuum pump adaptor
Torque wrench	Electronic refrigerant charging scale

Keep the tools with care.

If dirt, dust or moisture enter into refrigerant cycle, that can cause deterioration of refrigerant oil or malfunction of compressor.

Do not use a charging cylinder.

If a charging cylinder is used, the composition of refrigerant will change and the efficiency will be lowered.

Ventilate the room if refrigerant leaks during operation. If refrigerant comes into contact with a flame, poisonous gases will be released.

[1] Cautions for service

- (1) Perform service after collecting the refrigerant left in unit completely.
- (2) Do not release refrigerant in the air.
- (3) After completing service, charge the cycle with specified amount of refrigerant.
- (4) When performing service, install a filter drier simultaneously.
Be sure to use a filter drier for new refrigerant.

[2] Additional refrigerant charge

When charging directly from cylinder

- Check that cylinder for R410A on the market is syphon type.
- Charging should be performed with the cylinder of syphon stood vertically. (Refrigerant is charged from liquid phase.)

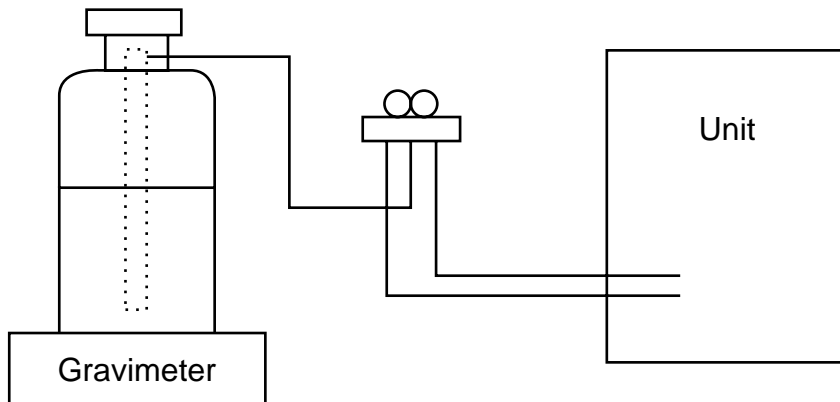

[3] Service tools

Use the below service tools as exclusive tools for R410A refrigerant.

No.		Specifications
①	Gauge manifold	-Only for R410A
		-Use the existing fitting specifications. (UNF1/2)
		-Use high-tension side pressure of 5.3MPa-G or over.
②	Charge hose	-Only for R410A
		-Use pressure performance of 5.09MPa-G or over.
③	Electronic scale	—
④	Gas leak detector	-Use the detector for R134a, R407C or R410A.
⑤	Adaptor for reverse flow check	-Attach on vacuum pump.
⑥	Refrigerant charge base	—
⑦	Refrigerant cylinder	-Only for R410A
		Top of cylinder (Pink) Cylinder with syphon
⑧	Refrigerant recovery equipment	—

3 PART NAMES AND FUNCTIONS

● Indoor Unit

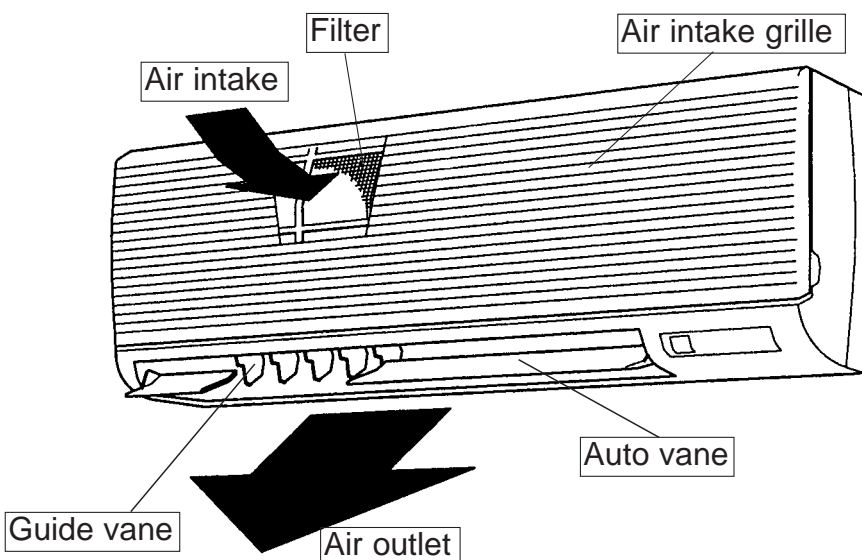

●Wireless remote controller

- When cover is open.

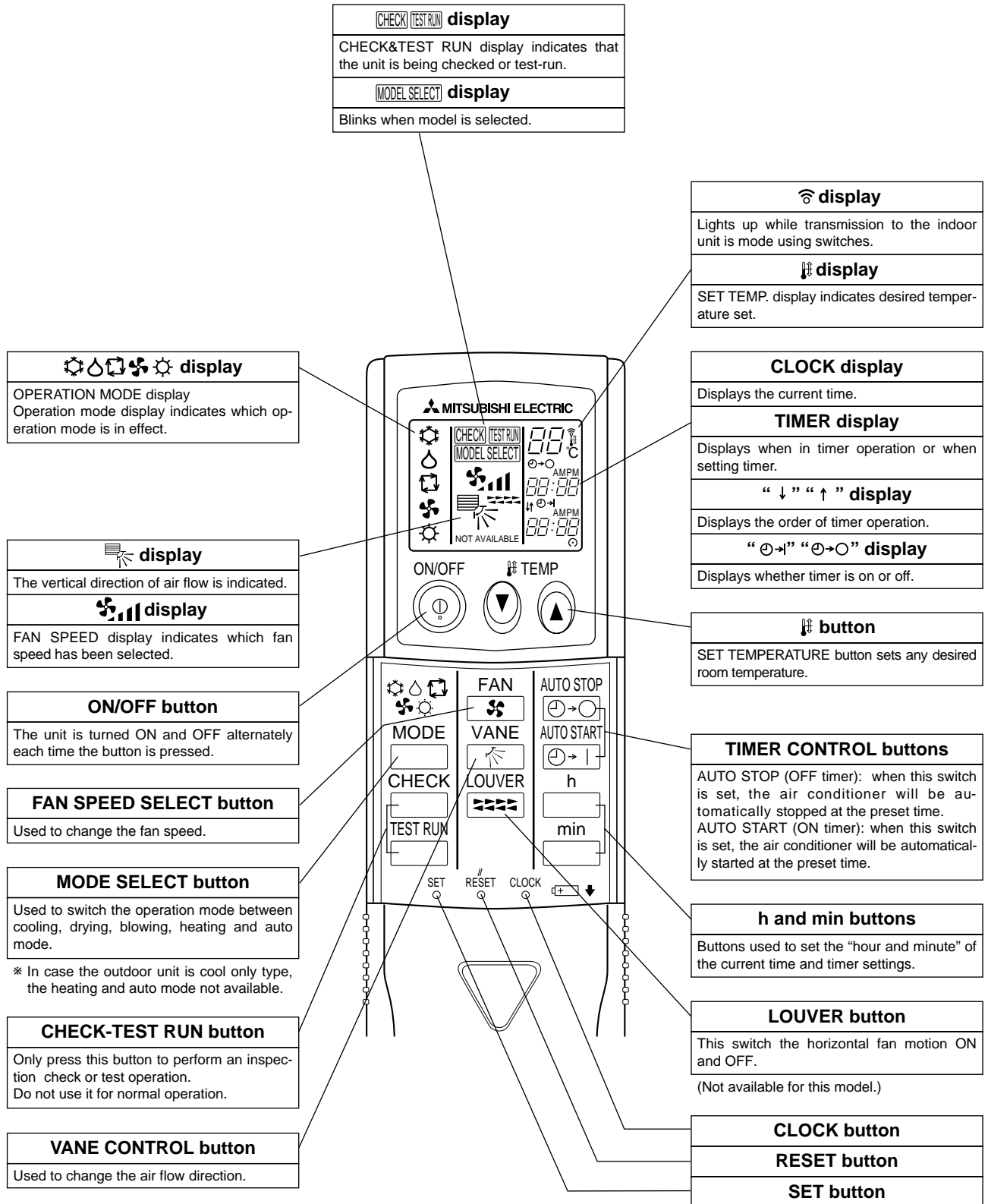

4

SPECIFICATIONS

4-1. Heat pump type (1)

Item		Service Ref.	PKA-RP1.6GAL	
Function			Cooling	Heating
Capacity		Btu/h	12,300	14,000
		W	3,600(1,600~4,500)	4,100(1,600~5,200)
Total input		kW	1.03	1.27
Service Ref.			PKA-RP1.6GAL	
Power supply(phase, cycle, voltage)			Single phase, 50Hz, 220-230-240V	
	Input	kW	0.07	0.07
	Running current	A	0.33	0.33
	Starting current	A	0.40	0.40
External finish			Munsell 0.70Y 8.59/0.97	
Heat exchanger			Plate fin coil	
INDOOR UNIT	Fan	Fan(drive) x No.		Line flow (direct) x 1
		Fan motor output		0.030
		Airflow(Lo-Mi2-Mi1-Hi)		9-10-11-12(320-355-390-425)
		External static pressure		0(direct blow)
Operation control & Thermostat			Wireless remote controller & built-in	
Noise level(Lo-Mi2-Mi1-Hi)		dB	36-38-41-43	
Unit drain pipe O.D.		mm(in.)	26(1)	
Dimensions	W	mm(in.)	990(39)	
	D	mm(in.)	235(9-1/4)	
	H	mm(in.)	340(13-3/8)	
Weight		kg(lbs)	16(35)	
OUTDOOR UNIT	Service Ref.		PUHZ-RP1.6VHA	

Item		Service Ref.	PKA-RP2GAL	
Function			Cooling	Heating
Capacity		Btu/h	15,700	15,400
		W	4,600(2,300~5,400)	4,500(2,500~6,200)
Total input		kW	1.63	1.40
Service Ref.			PKA-RP2GAL	
Power supply(phase, cycle, voltage)			Single phase, 50Hz, 220-230-240V	
	Input	kW	0.07	0.07
	Running current	A	0.33	0.33
	Starting current	A	0.40	0.40
External finish			Munsell 0.70Y 8.59/0.97	
Heat exchanger			Plate fin coil	
INDOOR UNIT	Fan	Fan(drive) x No.		Line flow (direct) x 1
		Fan motor output		0.030
		Airflow(Lo-Mi2-Mi1-Hi)		9-10-11-12(320-355-390-425)
		External static pressure		0(direct blow)
Operation control & Thermostat			Wireless remote controller & built-in	
Noise level(Lo-Mi2-Mi1-Hi)		dB	36-38-41-43	
Unit drain pipe O.D.		mm(in.)	26(1)	
Dimensions	W	mm(in.)	990(39)	
	D	mm(in.)	235(9-1/4)	
	H	mm(in.)	340(13-3/8)	
Weight		kg(lbs)	16(35)	
OUTDOOR UNIT	Service Ref.		PUHZ-RP2VHA	

Notes1. Rating Conditions (ISO T1)

Cooling : Indoor : D.B. 27°C(80°F), W.B. 19°C (66°F) Outdoor : D.B. 35°C(95°F), W.B. 24°C (75°F)
 Heating : Indoor : D.B. 20°C(68°F) Outdoor : D.B. 7°C(45°F), W.B. 6°C (43°F)
 Refrigerant piping length (one way) : 5m (16ft)

2. Guaranteed operating range

		Indoor	Outdoor
Cooling	Upper limit	D.B. 35°C, W.B. 22.5°C	D.B. 46°C
	Lower limit	D.B. 19°C, W.B. 15°C	D.B. -5°C
Heating	Upper limit	D.B. 28°C	D.B. 21°C, W.B. 15°C
	Lower limit	D.B. 17°C	D.B. -11°C, W.B. -12°C

3. Guaranteed voltage

198~264V, 50Hz

4. Above data based on indicated voltage

Indoor Unit Single phase 230V 50Hz
 Outdoor Unit Single phase 230V 50Hz

5. Refer to the service manual of outdoor unit for the outdoor unit's specifications.

4-2. Heat pump type (2)

Item		Service Ref.	PKA-RP1.6GAL	
Function			Cooling	Heating
Capacity		Btu/h	15,200	16,900
		W	4,450	4,950
Total input		kW	1.70	1.79
Service Ref.			PKA-RP1.6GAL	
Power supply(phase, cycle, voltage)			Single phase, 50Hz, 220-230-240V	
INDOOR UNIT	Input	kW	0.07	0.07
	Running current	A	0.33	0.33
	Starting current	A	0.40	0.40
External finish			Munsell 0.70Y 8.59/0.97	
Heat exchanger			Plate fin coil	
INDOOR UNIT	Fan	Fan(drive) x No.	Line flow (direct) x 1	
		Fan motor output	0.030	
		Airflow(Lo-Mi2-Mi1-Hi)	9-10-11-12(320-355-390-425)	
		External static pressure	0(direct blow)	
Operation control & Thermostat			Wireless remote controller & built-in	
Noise level(Lo-Mi2-Mi1-Hi)		dB	36-38-41-43	
Unit drain pipe O.D.		mm(in.)	26(1)	
INDOOR UNIT	Dimensions	W	990(39)	
		D	235(9-1/4)	
		H	340(13-3/8)	
Weight		kg(lbs)	16(35)	
OUTDOOR UNIT	Service Ref.		PUH-P1.6VGAA PUH-P1.6VGAA.UK / PUH-P1.6YGAA.UK PUH-P1.6VGAA₁.UK / PUH-P1.6YGAA₁.UK	

Item		Service Ref.	PKA-RP2GAL	
Function			Cooling	Heating
Capacity		Btu/h	18,300	21,200
		W	5,350	6,200
Total input		kW	2.33	2.34
Service Ref.			PKA-RP2GAL	
Power supply(phase, cycle, voltage)			Single phase, 50Hz, 220-230-240V	
INDOOR UNIT	Input	kW	0.07	0.07
	Running current	A	0.33	0.33
	Starting current	A	0.40	0.40
External finish			Munsell 0.70Y 8.59/0.97	
Heat exchanger			Plate fin coil	
INDOOR UNIT	Fan	Fan(drive) x No.	Line flow (direct) x 1	
		Fan motor output	0.030	
		Airflow(Lo-Mi2-Mi1-Hi)	9-10-11-12(320-355-390-425)	
		External static pressure	0(direct blow)	
Operation control & Thermostat			Wireless remote controller & built-in	
Noise level(Lo-Mi2-Mi1-Hi)		dB	36-38-41-43	
Unit drain pipe O.D.		mm(in.)	26(1)	
INDOOR UNIT	Dimensions	W	990(39)	
		D	235(9-1/4)	
		H	340(13-3/8)	
Weight		kg(lbs)	16(35)	
OUTDOOR UNIT	Service Ref.		PUH-P2VGAA PUH-P2VGAA.UK / PUH-P2YGAA.UK PUH-P2VGAA₁.UK / PUH-P2YGAA₁.UK	

Notes1. Rating Conditions (ISO T1)

Cooling : Indoor : D.B. 27°C(80°F), W.B. 19°C (66°F) Outdoor : D.B. 35°C(95°F), W.B. 24°C (75°F)
 Heating : Indoor : D.B. 20°C(68°F) Outdoor : D.B. 7°C(45°F), W.B. 6°C (43°F)
 Refrigerant piping length (one way) : 5m (16ft)

2. Guaranteed operating range

		Indoor	Outdoor
Cooling	Upper limit	D.B. 35°C, W.B. 22.5°C	D.B. 46°C
	Lower limit	D.B. 19°C, W.B. 15°C	D.B. -5°C
Heating	Upper limit	D.B. 28°C	D.B. 24°C, W.B. 18°C
	Lower limit	D.B. 17°C	D.B. -11°C, W.B. -12°C

3. Guaranteed voltage 198-264V, 50Hz

4. Above data based on indicated voltage
 Indoor Unit Single phase 230V 50Hz
 Outdoor Unit 3 phase 400V 50Hz

5. Refer to the service manual of outdoor unit for the outdoor unit's specifications.

4-3. Cooling only type

Item		Service Ref.	PKA-RP1.6GAL
Function			Cooling
Capacity		Btu/h	15,200
		W	4,450
Total input		kW	1.70
Service Ref.			PKA-RP1.6GAL
Power supply(phase, cycle, voltage)			Single phase, 50Hz, 220-230-240V
	Input	kW	0.07
	Running current	A	0.33
	Starting current	A	0.40
External finish			Munsell 0.70Y 8.59/0.97
Heat exchanger			Plate fin coil
INDOOR UNIT	Fan	Fan(drive) x No.	Line flow (direct) x 1
		Fan motor output	kW
		Airflow(Lo-Mi2-Mi1-Hi)	m ³ /min(CFM)
		External static pressure	Pa(mmAq)
Operation control & Thermostat			Wireless remote controller & built-in
Noise level(Lo-Mi2-Mi1-Hi)		dB	36-38-41-43
Unit drain pipe O.D.		mm(in.)	26(1)
Dimensions	W	mm(in.)	990(39)
	D	mm(in.)	235(9-1/4)
	H	mm(in.)	340(13-3/8)
Weight		kg(lbs)	16(35)
OUTDOOR UNIT	Service Ref.		PU-P1.6VGAA PU-P1.6VGAA.UK / PU-P1.6YGAA.UK PU-P1.6VGAA₁.UK / PU-P1.6YGAA₁.UK

Item		Service Ref.	PKA-RP2GAL
Function			Cooling
Capacity		Btu/h	18,300
		W	5,350
Total input		kW	2.33
Service Ref.			PKA-RP2GAL
Power supply(phase, cycle, voltage)			Single phase, 50Hz, 220-230-240V
	Input	kW	0.07
	Running current	A	0.33
	Starting current	A	0.40
External finish			Munsell 0.70Y 8.59/0.97
Heat exchanger			Plate fin coil
INDOOR UNIT	Fan	Fan(drive) x No.	Line flow (direct) x 1
		Fan motor output	kW
		Airflow(Lo-Mi2-Mi1-Hi)	m ³ /min(CFM)
		External static pressure	Pa(mmAq)
Operation control & Thermostat			Wireless remote controller & built-in
Noise level(Lo-Mi2-Mi1-Hi)		dB	36-38-41-43
Unit drain pipe O.D.		mm(in.)	26(1)
Dimensions	W	mm(in.)	990(39)
	D	mm(in.)	235(9-1/4)
	H	mm(in.)	340(13-3/8)
Weight		kg(lbs)	16(35)
OUTDOOR UNIT	Service Ref.		PU-P2VGAA PU-P2VGAA.UK / PU-P2YGAA.UK PU-P2VGAA₁.UK / PU-P2YGAA₁.UK

Notes1. Rating Conditions (ISO T1)

Cooling : Indoor : D.B. 27°C(80°F), W.B. 19°C (66°F) Outdoor : D.B. 35°C(95°F), W.B. 24°C (75°F)
Refrigerant piping length (one way) : 5m (16ft)

2. Guaranteed operating range

		Indoor	Outdoor
Cooling	Upper limit	D.B. 35°C, W.B. 22.5°C	D.B. 46°C
	Lower limit	D.B. 19°C, W.B. 15°C	D.B. -5°C

3. Guaranteed voltage
198~264V, 50Hz

4. Above data based on indicated voltage
Indoor Unit Single phase 230V 50Hz
Outdoor Unit 3 phase 400V 50Hz

5. Refer to the service manual of outdoor unit for the outdoor unit's specifications.

5-1. PERFORMANCE DATA

COOLING CAPACITY(1)

PKA-RP1.6GAL / PUHZ-RP1.6VHA

(230V)

Indoor Intake air D.B.(°C)	Indoor Intake air W.B.(°C)	Outdoor intake air D.B.(°C)											
		20				25				30			
		CA	SHC(W)	SHF	P.C.	CA	SHC(W)	SHF	P.C.	CA	SHC(W)	SHF	P.C.
20	16	3,564	2,637	0.74	0.82	3,456	2,257	0.74	0.87	3,348	2,478	0.74	0.92
20	18	3,816	2,366	0.62	0.84	3,708	2,299	0.62	0.89	3,582	2,221	0.62	0.95
20	20	4,104	2,052	0.50	0.87	4,014	2,007	0.50	0.91	3,906	1,953	0.50	0.97
22	16	3,564	2,922	0.82	0.82	3,456	2,834	0.82	0.87	3,348	2,745	0.82	0.92
22	18	3,816	2,671	0.70	0.84	3,708	2,596	0.70	0.89	3,582	2,507	0.70	0.95
22	20	4,104	2,380	0.58	0.87	4,014	2,328	0.58	0.91	3,906	2,265	0.58	0.97
24	16	3,564	3,208	0.90	0.82	3,456	3,110	0.90	0.87	3,348	3,013	0.90	0.92
24	18	3,816	2,976	0.78	0.84	3,708	2,892	0.78	0.89	3,582	2,794	0.78	0.95
24	20	4,104	2,709	0.66	0.87	4,014	2,649	0.66	0.91	3,906	2,578	0.66	0.97
24	22	4,374	2,362	0.54	0.89	4,284	2,313	0.54	0.94	4,176	2,255	0.54	1.00
26	16	3,564	3,493	0.98	0.82	3,456	3,387	0.998	0.87	3,348	3,281	0.98	0.92
26	18	3,816	3,282	0.86	0.84	3,708	3,189	0.86	0.89	3,582	3,081	0.86	0.95
26	20	4,104	3,037	0.74	0.87	4,014	2,970	0.74	0.91	3,906	2,890	0.74	0.97
26	22	4,374	2,712	0.62	0.89	4,284	2,656	0.62	0.94	4,176	2,589	0.62	1.00
27	16	3,564	3,564	1.00	0.82	3,456	3,456	1.00	0.87	3,348	3,348	1.00	0.92
27	18	3,816	3,434	0.90	0.84	3,708	3,337	0.90	0.89	3,582	3,224	0.90	0.95
27	20	4,104	3,201	0.78	0.87	4,014	3,131	0.78	0.91	3,906	3,047	0.78	0.97
27	22	4,374	2,887	0.66	0.89	4,284	2,827	0.66	0.94	4,176	2,756	0.65	1.00
28	16	3,564	3,564	1.00	0.82	3,456	3,456	1.00	0.87	3,348	3,348	1.00	0.92
28	18	3,816	3,587	0.94	0.84	3,708	3,486	0.94	0.89	3,582	3,367	0.94	0.95
28	20	4,104	3,356	0.82	0.87	4,014	3,291	0.82	0.91	3,906	3,203	0.82	0.97
28	22	4,374	3,062	0.70	0.89	4,284	2,999	0.70	0.94	4,176	2,923	0.70	1.00
30	16	3,564	3,564	1.00	0.82	3,456	3,456	1.00	0.87	3,348	3,348	1.00	0.92
30	18	3,816	3,816	1.00	0.84	3,708	3,708	1.00	0.89	3,582	3,582	1.00	0.95
30	20	4,104	3,694	0.90	0.87	4,014	3,613	0.90	0.91	3,906	3,515	0.90	0.97
30	22	4,374	3,412	0.78	0.89	4,284	3,342	0.78	0.94	4,176	3,257	0.78	1.00
32	16	3,564	3,564	1.00	0.82	3,456	3,456	1.00	0.87	3,348	3,348	1.00	0.92
32	18	3,816	3,816	1.00	0.84	3,708	3,708	1.00	0.89	3,582	3,582	1.00	0.95
32	20	4,104	4,022	0.98	0.87	4,014	3,934	0.98	0.91	3,906	3,828	0.98	0.97
32	22	4,374	3,762	0.86	0.89	4,284	3,684	0.86	0.94	4,176	3,591	0.86	1.00
34	16	3,564	3,564	1.00	0.82	3,456	3,456	1.00	0.87	3,348	3,348	1.00	0.92
34	18	3,816	3,816	1.00	0.84	3,708	3,708	1.00	0.89	3,582	3,582	1.00	0.95
34	20	4,104	4,104	1.00	0.87	4,014	4,014	1.00	0.91	3,906	3,906	1.00	0.97
34	22	4,374	4,112	0.94	0.89	4,284	4,027	0.94	0.94	4,176	3,925	0.94	1.00

CA : Capacity (W)

P.C. : Power consumption (kW)

SHC(W) : Sensible heat capacity

SHF : Sensible heat factor

**COOLING CAPACITY(2)
PKA-RP1.6GAL / PUHZ-RP1.6VHA**

(230V)

Indoor Intake air D.B.(°C)	Indoor Intake air W.B.(°C)	Outdoor intake air D.B.(°C)											
		35				40				45			
		CA	SHC(W)	SHF	P.C.	CA	SHC(W)	SHF	P.C.	CA	SHC(W)	SHF	P.C.
20	16	3,204	2,371	0.74	0.99	3,060	2,264	0.74	1.06	2,916	2,158	0.74	1.15
20	18	3,456	2,143	0.62	1.01	3,348	2,076	0.62	1.09	3,132	1,942	0.62	1.17
20	20	3,744	1,872	0.50	1.04	3,600	1,800	0.50	1.11	3,384	1,692	0.50	1.19
22	16	3,204	2,627	0.82	0.99	3,060	2,509	0.82	1.06	2,916	2,391	0.82	1.15
22	18	3,456	2,419	0.70	1.01	3,348	2,344	0.70	1.09	3,132	2,192	0.70	1.17
22	20	3,744	2,172	0.58	1.04	3,600	2,088	0.58	1.11	3,384	1,963	0.58	1.19
24	16	3,204	2,884	0.90	0.99	3,060	2,754	0.90	1.06	2,916	2,624	0.90	1.15
24	18	3,456	2,696	0.78	1.01	3,348	2,611	0.78	1.09	3,132	2,443	0.78	1.17
24	20	3,744	2,471	0.66	1.04	3,600	2,376	0.66	1.11	3,384	2,233	0.66	1.19
24	22	4,032	2,177	0.54	1.06	3,888	2,100	0.54	1.14	3,672	1,983	0.54	1.22
26	16	3,204	3,140	0.98	0.99	3,060	2,999	0.98	1.06	2,916	2,858	0.98	1.15
26	18	3,456	2,972	0.86	1.01	3,348	2,879	0.86	1.09	3,132	2,694	0.86	1.17
26	20	3,744	2,771	0.74	1.04	3,600	2,664	0.74	1.11	3,384	2,504	0.74	1.19
26	22	4,032	2,500	0.62	1.06	3,888	2,411	0.62	1.14	3,672	2,277	0.62	1.22
27	16	3,204	3,204	1.00	0.99	3,060	3,060	1.00	1.06	2,916	2,916	1.00	1.15
27	18	3,456	3,110	0.90	1.01	3,348	3,013	0.90	1.09	3,132	2,819	0.90	1.17
27	20	3,744	2,920	0.78	1.04	3,600	2,808	0.78	1.11	3,384	2,640	0.78	1.19
27	22	4,032	2,661	0.66	1.06	3,888	2,566	0.66	1.14	3,672	2,424	0.66	1.22
28	16	3,204	3,204	1.00	0.99	3,060	3,060	1.00	1.06	2,916	2,916	1.00	1.15
28	18	3,456	3,249	0.94	1.01	3,348	3,147	0.94	1.09	3,132	2,944	0.94	1.17
28	20	3,744	3,070	0.82	1.04	3,600	2,952	0.82	1.11	3,384	2,775	0.82	1.19
28	22	4,032	2,822	0.70	1.06	3,888	2,722	0.70	1.14	3,672	2,570	0.70	1.22
30	16	3,204	3,204	1.00	0.99	3,060	3,060	1.00	1.06	2,916	2,916	1.00	1.15
30	18	3,456	3,456	1.00	1.01	3,348	3,348	1.00	1.09	3,132	3,132	1.00	1.17
30	20	3,744	3,370	0.90	1.04	3,600	3,240	0.90	1.11	3,384	3,046	0.90	1.19
30	22	4,032	3,145	0.78	1.06	3,888	3,033	0.78	1.14	3,672	2,864	0.78	1.22
32	16	3,204	3,204	1.00	0.99	3,060	3,060	1.00	1.06	2,916	2,916	1.00	1.15
32	18	3,456	3,456	1.00	1.01	3,348	3,488	1.00	1.09	3,132	3,132	1.00	1.17
32	20	3,744	3,669	0.98	1.04	3,600	3,528	0.98	1.11	3,384	3,316	0.98	1.19
32	22	4,032	3,468	0.86	1.06	3,888	3,344	0.86	1.14	3,672	3,158	0.86	1.22
34	16	3,204	3,204	1.00	0.99	3,060	3,060	1.00	1.06	2,916	2,916	1.00	1.15
34	18	3,456	3,456	1.00	1.01	3,348	3,348	1.00	1.09	3,132	3,132	1.00	1.17
34	20	3,744	3,744	1.00	1.04	3,600	3,600	1.00	1.11	3,384	3,384	1.00	1.19
34	22	4,032	3,790	0.94	1.06	3,888	3,655	0.94	1.14	3,672	3,452	0.94	1.22

CA : Capacity (W)
P.C. : Power consumption (kW)

SHC(W) : Sensible heat capacity
SHF : Sensible heat factor

**COOLING CAPACITY(3)
PKA-RP2GAL / PUHZ-RP2VHA**

(230V)

Indoor Intake air D.B.(°C)	Indoor Intake air W.B.(°C)	Outdoor intake air D.B.(°C)											
		20				25				30			
		CA	SHC(W)	SHF	P.C.	CA	SHC(W)	SHF	P.C.	CA	SHC(W)	SHF	P.C.
20	16	4,554	2,915	0.64	1.30	4,416	2,826	0.64	1.38	4,278	2,738	0.64	1.46
20	18	4,876	2,536	0.52	1.33	4,738	2,464	0.52	1.40	4,577	2,380	0.52	1.50
20	20	5,244	2,098	0.40	1.37	5,129	2,052	0.40	1.43	4,991	1,996	0.40	1.53
22	16	4,554	3,279	0.72	1.30	4,416	3,180	0.72	1.38	4,278	3,080	0.72	1.46
22	18	4,876	2,926	0.60	1.33	4,738	2,843	0.60	1.40	4,577	2,746	0.60	1.50
22	20	5,244	2,517	0.48	1.37	5,129	2,462	0.48	1.43	4,991	2,396	0.48	1.53
24	16	4,554	3,643	0.80	1.30	4,416	3,533	0.80	1.38	4,278	3,422	0.80	1.46
24	18	4,876	3,316	0.68	1.33	4,738	3,222	0.68	1.40	4,577	3,112	0.68	1.50
24	20	5,244	2,937	0.56	1.37	5,129	2,872	0.56	1.43	4,991	2,795	0.56	1.53
24	22	5,589	2,459	0.44	1.40	5,474	2,409	0.44	1.48	5,336	2,348	0.44	1.58
26	16	4,554	4,008	0.88	1.30	4,416	3,886	0.88	1.38	4,278	3,765	0.88	1.46
26	18	4,876	3,706	0.76	1.33	4,738	3,601	0.76	1.40	4,577	3,479	0.76	1.50
26	20	5,244	3,356	0.64	1.37	5,129	3,283	0.64	1.43	4,991	3,194	0.64	1.53
26	22	5,589	2,906	0.52	1.40	5,474	2,846	0.52	1.48	5,336	2,775	0.52	1.58
27	16	4,554	4,190	0.92	1.30	4,416	4,063	0.92	1.38	4,278	3,936	0.92	1.46
27	18	4,876	3,901	0.80	1.33	4,738	3,790	0.80	1.40	4,577	3,662	0.80	1.50
27	20	5,244	3,566	0.68	1.37	5,129	3,488	0.68	1.43	4,991	3,394	0.68	1.53
27	22	5,589	3,130	0.56	1.40	5,474	3,065	0.56	1.48	5,336	2,988	0.56	1.58
28	16	4,554	4,372	0.96	1.30	4,416	4,239	0.96	1.38	4,278	4,107	0.96	1.46
28	18	4,876	4,096	0.84	1.33	4,738	3,980	0.84	1.40	4,577	3,845	0.84	1.50
28	20	5,244	3,776	0.72	1.37	5,129	3,693	0.72	1.43	4,991	3,594	0.72	1.53
28	22	5,589	3,353	0.60	1.40	5,474	3,284	0.60	1.48	5,336	3,202	0.60	1.58
30	16	4,554	4,554	1.00	1.30	4,416	4,416	1.00	1.38	4,278	4,278	1.00	1.46
30	18	4,876	4,486	0.92	1.33	4,738	4,359	0.92	1.40	4,577	4,211	0.92	1.50
30	20	5,244	4,195	0.80	1.37	5,129	4,103	0.80	1.43	4,991	3,993	0.80	1.53
30	22	5,589	3,801	0.68	1.40	5,474	3,722	0.68	1.48	5,336	3,628	0.68	1.58
32	16	4,554	4,554	1.00	1.30	4,416	4,416	1.00	1.38	4,278	4,278	1.00	1.46
32	18	4,876	4,876	1.00	1.33	4,738	4,738	1.00	1.40	4,577	4,577	1.00	1.50
32	20	5,244	4,615	0.88	1.37	5,129	4,514	0.88	1.43	4,991	4,392	0.88	1.53
32	22	5,589	4,248	0.76	1.40	5,474	4,160	0.76	1.48	5,336	4,055	0.76	1.58
34	16	4,554	4,554	1.00	1.30	4,416	4,416	1.00	1.38	4,278	4,278	1.00	1.46
34	18	4,876	4,876	1.00	1.33	4,738	4,738	1.00	1.40	4,577	4,577	1.00	1.50
34	20	5,244	5,034	0.96	1.37	5,129	4,924	0.96	1.43	4,991	4,791	0.96	1.53
34	22	5,589	4,695	0.84	1.40	5,474	4,598	0.84	1.48	5,336	4,482	0.84	1.58

CA : Capacity (W)

P.C. : Power consumption (kW)

SHC(W) : Sensible heat capacity

SHF : Sensible heat factor

**COOLING CAPACITY(4)
PKA-RP2GAL / PUAZ-RP2VHA**

(230V)

Indoor Intake air D.B.(°C)	Indoor Intake air W.B.(°C)	Outdoor intake air D.B.(°C)											
		35				40				45			
		CA	SHC(W)	SHF	P.C.	CA	SHC(W)	SHF	P.C.	CA	SHC(W)	SHF	P.C.
20	16	4,094	2,620	0.64	1.56	3,910	2,502	0.64	1.68	3,726	2,385	0.64	1.82
20	18	4,416	2,296	0.52	1.61	4,278	2,225	0.52	1.73	4,022	2,081	0.52	1.86
20	20	4,784	1,914	0.40	1.65	4,600	1,840	0.40	1.76	4,324	1,730	0.40	1.89
22	16	4,094	2,948	0.72	1.56	3,910	2,815	0.72	1.68	3,726	2,683	0.72	1.82
22	18	4,416	2,650	0.60	1.61	4,278	2,567	0.60	1.73	4,002	2,401	0.60	1.86
22	20	4,784	2,296	0.48	1.65	4,600	2,208	0.48	1.76	4,324	2,076	0.48	1.89
24	16	4,094	3,275	0.80	1.56	3,910	3,128	0.80	1.68	3,726	2,981	0.80	1.82
24	18	4,416	3,003	0.68	1.61	4,278	2,909	0.68	1.73	4,002	2,721	0.68	1.86
24	20	4,784	2,679	0.56	1.65	4,600	2,576	0.56	1.76	4,324	2,421	0.56	1.89
24	22	5,152	2,267	0.44	1.68	4,968	2,186	0.44	1.81	4,692	2,064	0.44	1.92
26	16	4,094	3,603	0.88	1.56	3,910	3,441	0.88	1.68	3,726	3,279	0.88	1.82
26	18	4,416	3,356	0.76	1.61	4,278	3,251	0.76	1.73	4,002	3,042	0.76	1.86
26	20	4,784	3,062	0.64	1.65	4,600	2,944	0.64	1.76	4,324	2,767	0.64	1.89
26	22	5,152	2,679	0.52	1.68	4,968	2,583	0.52	1.81	4,692	2,440	0.52	1.92
27	16	4,094	3,766	0.92	1.56	3,910	3,597	0.92	1.68	3,726	3,428	0.92	1.82
27	18	4,416	3,533	0.80	1.61	4,278	3,594	0.80	1.73	4,002	3,202	0.80	1.86
27	20	4,784	3,253	0.68	1.65	4,600	3,312	0.68	1.76	4,324	2,940	0.68	1.89
27	22	5,152	2,885	0.56	1.68	4,968	2,981	0.56	1.81	4,692	2,628	0.56	1.92
28	16	4,094	3,930	0.96	1.56	3,910	3,754	0.96	1.68	3,726	3,577	0.96	1.82
28	18	4,416	3,709	0.84	1.61	4,278	3,594	0.84	1.73	4,002	3,362	0.84	1.86
28	20	4,784	3,444	0.72	1.65	4,600	3,312	0.72	1.76	4,324	3,113	0.72	1.89
28	22	5,152	3,091	0.60	1.68	4,968	2,981	0.60	1.81	4,692	2,815	0.60	1.92
30	16	4,094	4,094	1.00	1.56	3,910	3,910	1.00	1.68	3,726	3,726	1.00	1.82
30	18	4,416	4,063	0.92	1.61	4,278	3,936	0.92	1.73	4,002	3,682	0.92	1.86
30	20	4,784	3,827	0.80	1.65	4,600	3,680	0.80	1.76	4,324	3,459	0.80	1.89
30	22	5,152	3,503	0.68	1.68	4,968	3,378	0.68	1.81	4,692	3,191	0.68	1.92
32	16	4,094	4,094	1.00	1.56	3,910	3,910	1.00	1.68	3,726	3,726	1.00	1.82
32	18	4,416	4,416	1.00	1.61	4,278	4,278	1.00	1.73	4,002	4,002	1.00	1.86
32	20	4,784	4,210	0.88	1.65	4,600	4,048	0.88	1.76	4,324	3,805	0.88	1.89
32	22	5,152	3,916	0.76	1.68	4,968	3,776	0.76	1.81	4,692	3,566	0.76	1.92
34	16	4,094	4,094	1.00	1.56	3,910	3,910	1.00	1.68	3,726	3,726	1.00	1.82
34	18	4,416	4,416	1.00	1.61	4,278	4,278	1.00	1.73	4,002	4,002	1.00	1.86
34	20	4,784	4,593	0.96	1.65	4,600	4,416	0.96	1.76	4,324	4,151	0.96	1.89
34	22	5,152	4,328	0.84	1.68	4,968	4,173	0.84	1.81	4,692	3,941	0.84	1.92

CA : Capacity (W)
P.C. : Power consumption (kW)

SHC(W) : Sensible heat capacity
SHF : Sensible heat factor

COOLING CAPACITY(5)

PKA-RP1.6GAL / PUH-P1.6VGAA

PUH-P1.6VGAA.UK PUH-P1.6YGAA.UK

PUH-P1.6VGAA₁.UK PUH-P1.6YGAA₁.UK

PU-P1.6VGAA

PU-P1.6VGAA.UK PU-P1.6YGAA.UK

PU-P1.6VGAA₁.UK PU-P1.6YGAA₁.UK

(230V)

Indoor Intake air D.B.(°C)	Indoor Intake air W.B.(°C)	Outdoor intake air D.B.(°C)											
		20				25				30			
		CA	SHC(W)	SHF	P.C.	CA	SHC(W)	SHF	P.C.	CA	SHC(W)	SHF	P.C.
20	16	4,406	2,952	0.67	1.36	4,272	2,862	0.67	1.44	4,139	2,773	0.67	1.52
20	18	4,417	2,594	0.55	1.39	4,584	2,521	0.55	1.46	4,428	2,435	0.55	1.56
20	20	5,073	2,181	0.43	1.43	4,962	2,134	0.43	1.50	4,828	2,076	0.43	1.60
22	16	4,406	3,304	0.75	1.36	4,272	3,204	0.75	1.44	4,139	3,104	0.75	1.52
22	18	4,717	2,972	0.63	1.39	4,584	2,888	0.63	1.46	4,428	2,789	0.63	1.56
22	20	5,073	2,587	0.51	1.43	4,962	2,530	0.51	1.50	4,828	2,462	0.51	1.60
24	16	4,406	3,657	0.83	1.36	4,272	3,546	0.83	1.44	4,139	3,435	0.83	1.52
24	18	4,717	3,349	0.71	1.39	4,584	3,254	0.71	1.46	4,428	3,144	0.71	1.56
24	20	5,073	2,993	0.59	1.43	4,962	2,927	0.59	1.50	4,828	2,849	0.59	1.60
24	22	5,407	2,541	0.47	1.46	5,296	2,489	0.47	1.55	5,162	2,426	0.47	1.65
26	16	4,406	4,009	0.91	1.36	4,272	3,888	0.91	1.44	4,139	3,766	0.91	1.52
26	18	4,717	3,726	0.79	1.39	4,584	3,621	0.79	1.46	4,428	3,498	0.79	1.56
26	20	5,073	3,399	0.67	1.43	4,962	3,324	0.67	1.50	4,828	3,235	0.67	1.60
26	22	5,407	2,974	0.55	1.46	5,296	2,913	0.55	1.55	5,162	2,839	0.55	1.65
27	16	4,406	4,185	0.95	1.36	4,272	4,058	0.95	1.44	4,139	3,932	0.95	1.52
27	18	4,717	3,915	0.83	1.39	4,584	3,804	0.83	1.46	4,428	3,675	0.83	1.56
27	20	5,073	3,602	0.71	1.43	4,962	3,523	0.71	1.50	4,828	3,428	0.71	1.60
27	22	5,407	3,190	0.59	1.46	5,296	3,124	0.59	1.55	5,162	3,046	0.59	1.65
28	16	4,406	4,361	0.99	1.36	4,272	4,229	0.99	1.44	4,139	4,097	0.99	1.52
28	18	4,717	4,104	0.87	1.39	4,584	3,988	0.87	1.46	4,428	3,852	0.87	1.56
28	20	5,073	3,805	0.75	1.43	4,962	3,721	0.75	1.50	4,828	3,621	0.75	1.60
28	22	5,407	3,406	0.63	1.46	5,296	3,336	0.63	1.55	5,162	3,252	0.63	1.65
30	16	4,406	4,406	1.00	1.36	4,272	4,272	1.00	1.44	4,139	4,139	1.00	1.52
30	18	4,717	4,481	0.95	1.39	4,584	4,354	0.95	1.46	4,428	4,206	0.95	1.56
30	20	5,073	4,211	0.83	1.43	4,962	4,118	0.83	1.50	4,828	4,007	0.83	1.60
30	22	5,407	3,839	0.71	1.46	5,296	3,760	0.71	1.55	5,162	3,665	0.71	1.65
32	16	4,406	4,406	1.00	1.36	4,272	4,272	1.00	1.44	4,139	4,139	1.00	1.52
32	18	4,717	4,717	1.00	1.39	4,584	4,584	1.00	1.46	4,428	4,428	1.00	1.56
32	20	5,073	4,616	0.91	1.43	4,962	4,515	0.91	1.50	4,828	4,394	0.91	1.60
32	22	5,407	4,271	0.79	1.46	5,296	4,183	0.79	1.55	5,162	4,078	0.79	1.65
34	16	4,406	4,406	1.00	1.36	4,272	4,272	1.00	1.44	4,139	4,139	1.00	1.52
34	18	4,717	4,717	1.00	1.39	4,584	4,584	1.00	1.46	4,428	4,428	1.00	1.56
34	20	5,073	5,022	0.99	1.43	4,962	4,912	0.99	1.50	4,828	4,780	0.99	1.60
34	22	5,407	4,704	0.87	1.46	5,296	4,607	0.87	1.55	5,162	4,491	0.87	1.65

CA : Capacity (W)

P.C. : Power consumption (kW)

SHC(W) : Sensible heat capacity

SHF : Sensible heat factor

COOLING CAPACITY(6)

PKA-RP1.6GAL / PUH-P1.6VGAA

PUH-P1.6VGAA.UK PUH-P1.6YGAA.UK
PUH-P1.6VGAA₁.UK PUH-P1.6YGAA₁.UK
PU-P1.6VGAA
PU-P1.6VGAA.UK PU-P1.6YGAA.UK
PU-P1.6VGAA₁.UK PU-P1.6YGAA₁.UK

(230V)

Indoor Intake air D.B.(°C)	Indoor Intake air W.B.(°C)	Outdoor intake air D.B.(°C)											
		35				40				45			
		CA	SHC(W)	SHF	P.C.	CA	SHC(W)	SHF	P.C.	CA	SHC(W)	SHF	P.C.
20	16	3,961	2,654	0.67	1.63	3,783	2,534	0.67	1.75	3,605	2,415	0.67	1.90
20	18	4,272	2,350	0.55	1.67	4,139	2,276	0.55	1.80	3,872	2,129	0.55	1.94
20	20	4,628	1,990	0.43	1.72	4,450	1,914	0.43	1.84	4,183	1,799	0.43	1.97
22	16	3,961	2,970	0.75	1.63	3,783	2,837	0.75	1.75	3,605	2,703	0.75	1.90
22	18	4,272	2,691	0.63	1.67	4,139	2,607	0.63	1.80	3,872	2,439	0.63	1.94
22	20	4,628	2,360	0.51	1.72	4,450	2,270	0.51	1.84	4,183	2,133	0.51	1.97
24	16	3,961	3,287	0.83	1.63	3,783	3,139	0.83	1.75	3,605	2,992	0.83	1.90
24	18	4,272	3,033	0.71	1.67	4,139	2,938	0.71	1.80	3,872	2,749	0.71	1.94
24	20	4,628	2,731	0.59	1.72	4,450	2,626	0.59	1.84	4,183	2,468	0.59	1.97
24	22	4,984	2,342	0.47	1.75	4,806	2,259	0.47	1.89	4,539	2,133	0.47	2.01
26	16	3,961	3,604	0.91	1.63	3,783	3,442	0.91	1.75	3,605	3,280	0.91	1.90
26	18	4,272	3,375	0.79	1.67	4,139	3,269	0.79	1.80	3,872	3,058	0.79	1.94
26	20	4,628	3,101	0.67	1.72	4,450	2,982	0.67	1.84	4,183	2,803	0.67	1.97
26	22	4,984	2,741	0.55	1.75	4,806	2,643	0.55	1.89	4,539	2,496	0.55	2.01
27	16	3,961	3,762	0.95	1.63	3,783	3,593	0.95	1.75	3,605	3,424	0.95	1.90
27	18	4,272	3,546	0.83	1.67	4,139	3,435	0.83	1.80	3,872	3,213	0.83	1.94
27	20	4,628	3,286	0.71	1.72	4,450	3,160	0.71	1.84	4,183	2,970	0.71	1.97
27	22	4,984	2,941	0.59	1.75	4,806	2,836	0.59	1.89	4,539	2,678	0.59	2.01
28	16	3,961	3,921	0.99	1.63	3,783	3,745	0.99	1.75	3,605	3,568	0.99	1.90
28	18	4,272	3,717	0.87	1.67	4,139	3,600	0.87	1.80	3,872	3,368	0.87	1.94
28	20	4,628	3,471	0.75	1.72	4,450	3,338	0.75	1.84	4,183	3,137	0.75	1.97
28	22	4,984	3,140	0.63	1.75	4,806	3,028	0.63	1.89	4,539	2,860	0.63	2.01
30	16	3,961	3,961	1.00	1.63	3,783	3,783	1.00	1.75	3,605	3,605	1.00	1.90
30	18	4,272	4,058	0.95	1.67	4,139	3,932	0.95	1.80	3,872	3,678	0.95	1.94
30	20	4,628	3,841	0.83	1.72	4,450	3,694	0.83	1.84	4,183	3,472	0.83	1.97
30	22	4,984	3,539	0.71	1.75	4,806	3,412	0.71	1.89	4,539	3,223	0.71	2.01
32	16	3,961	3,961	1.00	1.63	3,783	3,783	1.00	1.75	3,605	3,605	1.00	1.90
32	18	4,272	4,272	1.00	1.67	4,139	4,139	1.00	1.80	3,872	3,872	1.00	1.94
32	20	4,628	4,211	0.91	1.72	4,450	4,050	0.91	1.84	4,183	3,807	0.91	1.97
32	22	4,984	3,937	0.79	1.75	4,806	3,797	0.79	1.89	4,539	3,586	0.79	2.01
34	16	3,961	3,961	1.00	1.63	3,783	3,783	1.00	1.75	3,605	3,605	1.00	1.90
34	18	4,272	4,272	1.00	1.67	4,139	4,139	1.00	1.80	3,872	3,872	1.00	1.94
34	20	4,628	4,582	0.99	1.72	4,450	4,406	0.99	1.84	4,183	4,141	0.99	1.97
34	22	4,984	4,336	0.87	1.75	4,806	4,181	0.87	1.89	4,539	3,949	0.87	2.01

CA : Capacity (W)
P.C. : Power consumption (kW)

SHC(W) : Sensible heat capacity
SHF : Sensible heat factor

COOLING CAPACITY(7)

PKA-RP2GAL / PUH-P2VGAA

PUH-P2VGAA.UK

PUH-P2YGAA.UK

PUH-P2VGAA₁.UK

PUH-P2YGAA₁.UK

PU-P2VGAA

PU-P2VGAA.UK

PU-P2YGAA.UK

PU-P2VGAA₁.UK

PU-P2YGAA₁.UK

(230V)

Indoor Intake air D.B.(°C)	Indoor Intake air W.B.(°C)	Outdoor intake air D.B.(°C)											
		20				25				30			
		CA	SHC(W)	SHF	P.C.	CA	SHC(W)	SHF	P.C.	CA	SHC(W)	SHF	P.C.
20	16	5,297	3,178	0.60	1.86	5,136	3,082	0.60	1.97	4,976	2,985	0.60	2.09
20	18	5,671	2,722	0.48	1.90	5,511	2,645	0.48	2.00	5,323	2,555	0.48	2.14
20	20	6,099	2,196	0.36	1.96	5,965	2,147	0.36	2.05	5,805	2,090	0.36	2.19
22	16	5,297	3,602	0.68	1.86	5,136	3,492	0.68	1.97	4,976	3,383	0.68	2.09
22	18	5,671	3,176	0.56	1.90	5,511	3,086	0.56	2.00	5,323	2,981	0.56	2.14
22	20	6,099	2,684	0.44	1.96	5,965	2,625	0.44	2.05	5,805	2,554	0.44	2.19
24	16	5,297	4,025	0.76	1.86	5,136	3,903	0.76	1.97	4,976	3,781	0.76	2.09
24	18	5,671	3,629	0.64	1.90	5,511	3,527	0.64	2.00	5,323	3,407	0.64	2.14
24	20	6,099	3,171	0.52	1.96	5,965	3,102	0.52	2.05	5,805	3,018	0.52	2.19
24	22	6,500	2,600	0.40	2.00	6,367	2,547	0.40	2.12	6,206	2,482	0.40	2.26
26	16	5,297	4,449	0.84	1.86	5,136	4,314	0.84	1.97	4,976	4,179	0.84	2.09
26	18	5,671	4,083	0.72	1.90	5,511	3,968	0.72	2.00	5,323	3,833	0.72	2.14
26	20	6,099	3,659	0.60	1.96	5,965	3,579	0.60	2.05	5,805	3,483	0.60	2.19
26	22	6,500	3,120	0.48	2.00	6,367	3,056	0.48	2.12	6,206	2,979	0.48	2.26
27	16	5,297	4,661	0.88	1.86	5,136	4,520	0.88	1.97	4,976	4,378	0.88	2.09
27	18	5,671	4,310	0.76	1.90	5,511	4,188	0.76	2.00	5,323	4,046	0.76	2.14
27	20	6,099	3,903	0.64	1.96	5,965	3,818	0.64	2.05	5,805	3,715	0.64	2.19
27	22	6,500	3,380	0.52	2.00	6,367	3,311	0.52	2.12	6,206	3,227	0.52	2.26
28	16	5,297	4,873	0.92	1.86	5,136	4,725	0.92	1.97	4,976	4,577	0.92	2.09
28	18	5,671	4,537	0.80	1.90	5,511	4,408	0.80	2.00	5,323	4,259	0.80	2.14
28	20	6,099	4,147	0.68	1.96	5,965	4,056	0.68	2.05	5,805	3,947	0.68	2.19
28	22	6,500	3,640	0.56	2.00	6,367	3,565	0.56	2.12	6,206	3,475	0.56	2.26
30	16	5,297	5,297	1.00	1.86	5,136	5,136	1.00	1.97	4,976	4,976	1.00	2.09
30	18	5,671	4,990	0.88	1.90	5,511	4,849	0.88	2.00	5,323	4,684	0.88	2.14
30	20	6,099	4,635	0.76	1.96	5,965	4,534	0.76	2.05	5,805	4,412	0.76	2.19
30	22	6,500	4,160	0.64	2.00	6,367	4,075	0.64	2.12	6,206	3,972	0.64	2.26
32	16	5,297	5,297	1.00	1.86	5,136	5,136	1.00	1.97	4,976	4,976	1.00	2.09
32	18	5,671	5,444	0.96	1.90	5,511	5,290	0.96	2.00	5,323	5,110	0.96	2.14
32	20	6,099	5,123	0.84	1.96	5,965	5,011	0.84	2.05	5,805	4,876	0.84	2.19
32	22	6,500	4,680	0.72	2.00	6,367	4,584	0.72	2.12	6,206	4,468	0.72	2.26
34	16	5,297	5,297	1.00	1.86	5,136	5,136	1.00	1.97	4,976	4,976	1.00	2.09
34	18	5,671	5,671	1.00	1.90	5,511	5,511	1.00	2.00	5,323	5,323	1.00	2.14
34	20	6,099	5,611	0.92	1.96	5,965	5,488	0.92	2.05	5,805	5,340	0.92	2.19
34	22	6,500	5,200	0.80	2.00	6,367	5,093	0.80	2.12	6,206	4,965	0.80	2.26

CA : Capacity (W)

P.C. : Power consumption (kW)

SHC(W) : Sensible heat capacity

SHF : Sensible heat factor

COOLING CAPACITY(8)

PKA-RP2GAL / PUH-P2VGAA

PUH-P2VGAA.UK

PUH-P2VGAA₁.UK

PU-P2VGAA

PU-P2VGAA.UK

PU-P2VGAA₁.UK

PUH-P2YGAA.UK

PUH-P2YGAA₁.UK

PU-P2YGAA.UK

PU-P2YGAA₁.UK

(230V)

Indoor Intake air D.B.(°C)	Indoor Intake air W.B.(°C)	Outdoor intake air D.B.(°C)											
		35				40				45			
		CA	SHC(W)	SHF	P.C.	CA	SHC(W)	SHF	P.C.	CA	SHC(W)	SHF	P.C.
20	16	4,762	2,857	0.60	2.24	4,548	2,729	0.60	2.40	4,334	2,600	0.60	2.60
20	18	5,136	2,465	0.48	2.30	4,976	2,388	0.48	2.47	4,655	2,234	0.48	2.66
20	20	5,564	2,003	0.36	2.35	5,350	1,926	0.36	2.52	5,029	1,810	0.36	2.70
22	16	4,762	3,238	0.68	2.24	4,548	3,092	0.68	2.40	4,334	2,947	0.68	2.60
22	18	5,136	2,876	0.56	2.30	4,976	2,786	0.56	2.47	4,655	2,607	0.56	2.66
22	20	5,564	2,448	0.44	2.35	5,350	2,354	0.44	2.52	5,029	2,213	0.44	2.70
24	16	4,762	3,619	0.76	2.24	4,548	3,456	0.76	2.40	4,334	3,293	0.76	2.60
24	18	5,136	3,287	0.64	2.30	4,976	3,184	0.64	2.47	4,655	2,979	0.64	2.66
24	20	5,564	2,893	0.52	2.35	5,350	2,782	0.52	2.52	5,029	2,615	0.52	2.70
24	22	5,992	2,397	0.40	2.40	5,778	2,311	0.40	2.59	5,457	2,183	0.40	2.75
26	16	4,762	4,000	0.84	2.24	4,548	3,820	0.84	2.40	4,334	3,640	0.84	2.60
26	18	5,136	3,698	0.72	2.30	4,976	3,582	0.72	2.47	4,655	3,351	0.72	2.66
26	20	5,564	3,338	0.60	2.35	5,350	3,210	0.60	2.52	5,029	3,017	0.60	2.70
26	22	5,992	2,876	0.48	2.40	5,778	2,773	0.48	2.59	5,457	2,619	0.48	2.75
27	16	4,762	4,190	0.88	2.24	4,548	4,002	0.88	2.40	4,334	3,813	0.88	2.60
27	18	5,136	3,903	0.76	2.30	4,976	3,781	0.76	2.47	4,655	3,537	0.76	2.66
27	20	5,564	3,561	0.64	2.35	5,350	3,424	0.64	2.52	5,029	3,219	0.64	2.70
27	22	5,992	3,116	0.52	2.40	5,778	3,005	0.52	2.59	5,457	2,838	0.52	2.75
28	16	4,762	4,381	0.92	2.24	4,548	4,184	0.92	2.40	4,334	3,987	0.92	2.60
28	18	5,136	4,109	0.80	2.30	4,976	3,980	0.80	2.47	4,655	3,724	0.80	2.66
28	20	5,564	3,784	0.68	2.35	5,350	3,638	0.68	2.52	5,029	3,420	0.68	2.70
28	22	5,992	3,356	0.56	2.40	5,778	3,236	0.56	2.59	5,457	3,056	0.56	2.75
30	16	4,762	4,762	1.00	2.24	4,548	4,548	1.00	2.40	4,334	4,334	1.00	2.60
30	18	5,136	4,520	0.88	2.30	4,976	4,378	0.88	2.47	4,655	4,096	0.88	2.66
30	20	5,564	4,229	0.76	2.35	5,350	4,066	0.76	2.52	5,029	3,822	0.76	2.70
30	22	5,992	3,835	0.64	2.40	5,778	3,698	0.64	2.59	5,457	3,492	0.64	2.75
32	16	4,762	4,762	1.00	2.24	4,548	4,548	1.00	2.40	4,334	4,334	1.00	2.60
32	18	5,136	4,931	0.96	2.30	4,976	4,776	0.96	2.47	4,655	4,468	0.96	2.66
32	20	5,564	4,674	0.84	2.35	5,350	4,494	0.84	2.52	5,029	4,224	0.84	2.70
32	22	5,992	4,314	0.72	2.40	5,778	4,160	0.72	2.59	5,457	3,929	0.72	2.75
34	16	4,762	4,762	1.00	2.24	4,548	4,548	1.00	2.40	4,334	4,334	1.00	2.60
34	18	5,136	5,136	1.00	2.30	4,976	4,976	1.00	2.47	4,655	4,655	1.00	2.66
34	20	5,564	5,119	0.92	2.35	5,350	4,922	0.92	2.52	5,029	4,627	0.92	2.70
34	22	5,992	4,794	0.80	2.40	5,778	4,622	0.80	2.59	5,457	4,366	0.80	2.75

CA : Capacity (W)
P.C. : Power consumption (kW)

SHC(W) : Sensible heat capacity
SHF : Sensible heat factor

HEATING CAPACITY (1)

PKA-RP•GAL / PUHZ-RP•VHA

(230V)

Service Ref.	Indoor intake air D.B. (°C)	Outdoor intake air W.B. (°C)											
		-10		-5		0		5		10		15	
		CA	P.C.	CA	P.C.	CA	P.C.	CA	P.C.	CA	P.C.	CA	P.C.
PKA-RP1.6GAL	15	2,604	0.75	2,829	0.83	3,157	0.95	4,141	1.14	4,674	1.27	5,207	1.37
	20	2,501	0.81	2,706	0.89	2,993	1.03	3,998	1.23	4,510	1.37	5,023	1.47
	25	2,419	0.86	2,624	0.97	2,870	1.12	3,772	1.31	4,346	1.47	4,838	1.58
PKA-RP2GAL	15	2,858	0.83	3,105	0.91	3,465	1.05	4,545	1.26	5,130	1.40	5,715	1.51
	20	2,745	0.90	2,970	0.98	3,285	1.13	4,388	1.36	4,950	1.51	5,513	1.62
	25	2,655	0.95	2,880	1.06	3,150	1.23	4,140	1.44	4,770	1.62	5,310	1.74

NOTE: CA: Capacity (W) P.C.: Power consumption (kW)

HEATING CAPACITY (2)

PKA-RP•GAL / PUH-P•VGAA PUH-P•VGAA.UK PUH-P•YGAA.UK
PUH-P•VGAA₁.UK PUH-P•YGAA₁.UK

(230V)

Service Ref.	Indoor intake air D.B. (°C)	Outdoor intake air W.B. (°C)											
		-10		-5		0		5		10		15	
		CA	P.C.	CA	P.C.	CA	P.C.	CA	P.C.	CA	P.C.	CA	P.C.
PKA-RP1.6GAL	15	3,143	1.06	3,416	1.16	3,812	1.34	5,000	1.61	5,643	1.79	6,287	1.93
	20	3,020	1.15	3,267	1.25	3,614	1.45	4,826	1.74	5,445	1.93	6,064	2.08
	25	2,921	1.22	3,168	1.36	3,465	1.58	4,554	1.84	5,247	2.07	5,841	2.23
PKA-RP2GAL	15	3,937	1.38	4,278	1.52	4,774	1.76	6,262	2.11	7,068	2.34	7,874	2.53
	20	3,782	1.50	4,092	1.64	4,526	1.90	6,045	2.27	6,820	2.53	7,595	2.71
	25	3,658	1.59	3,968	1.78	4,340	2.06	5,704	2.41	6,572	2.70	7,316	2.91

NOTE: CA: Capacity (W) P.C.: Power consumption (kW)

5-2. PERFORMANCE CURVE

PKA-RP•GAL / PUHZ-RP•VHA

Cooling performance curve(50Hz)

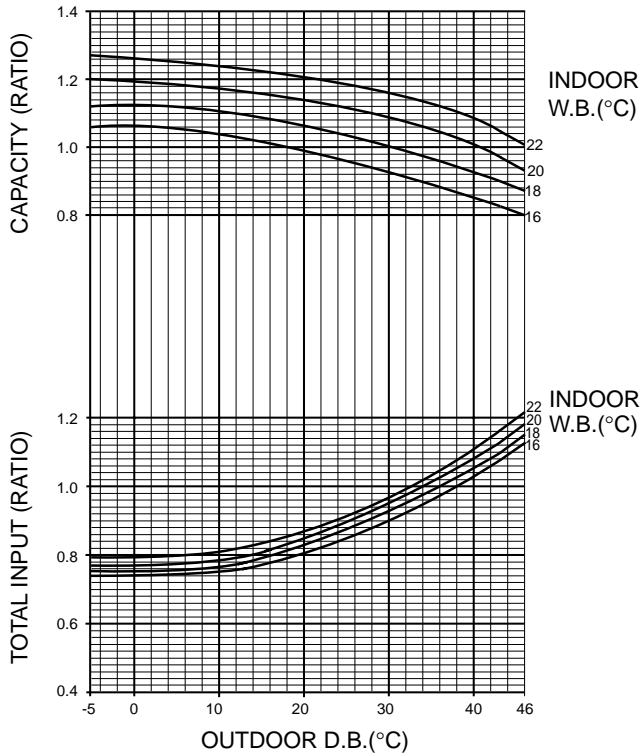

Heating performance curve(50Hz)

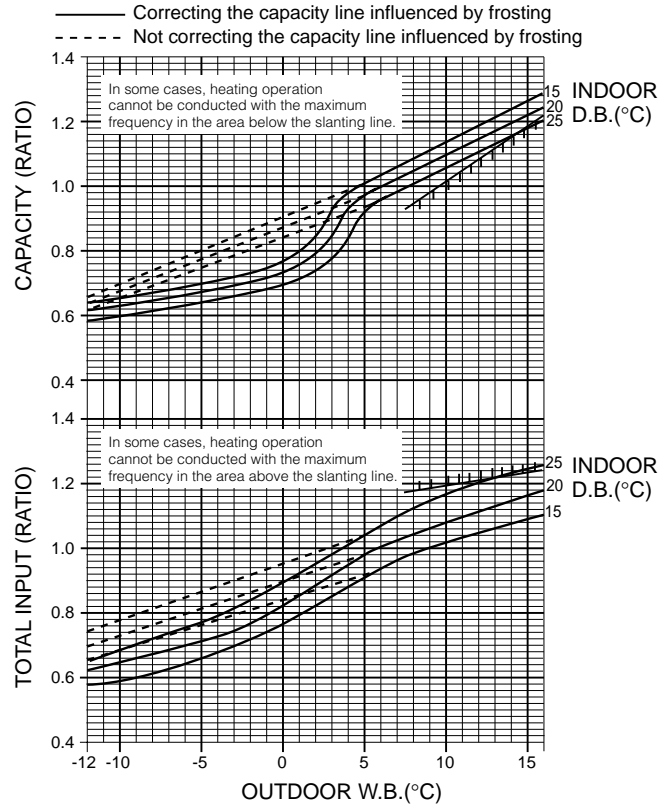

PKA-RP•GAL / PUH-P•VGAA PUH-P•VGAA.UK PUH-P•YGAA.UK
 PU-P•VGAA PU-P•VGAA.UK PU-P•YGAA.UK
 PUH-P•VGAA₁.UK PUH-P•YGAA₁.UK
 PU-P•VGAA₁.UK PU-P•YGAA₁.UK

Cooling performance curve(50Hz)

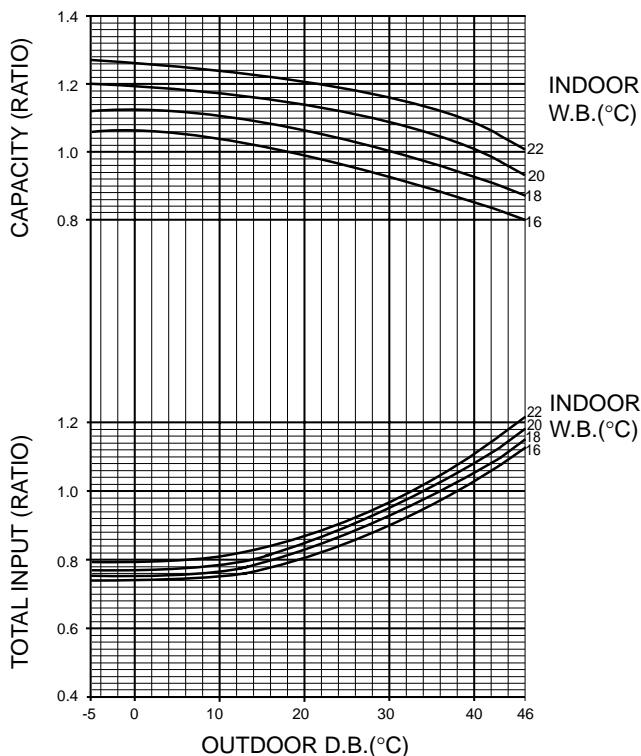

Heating performance curve(50Hz)

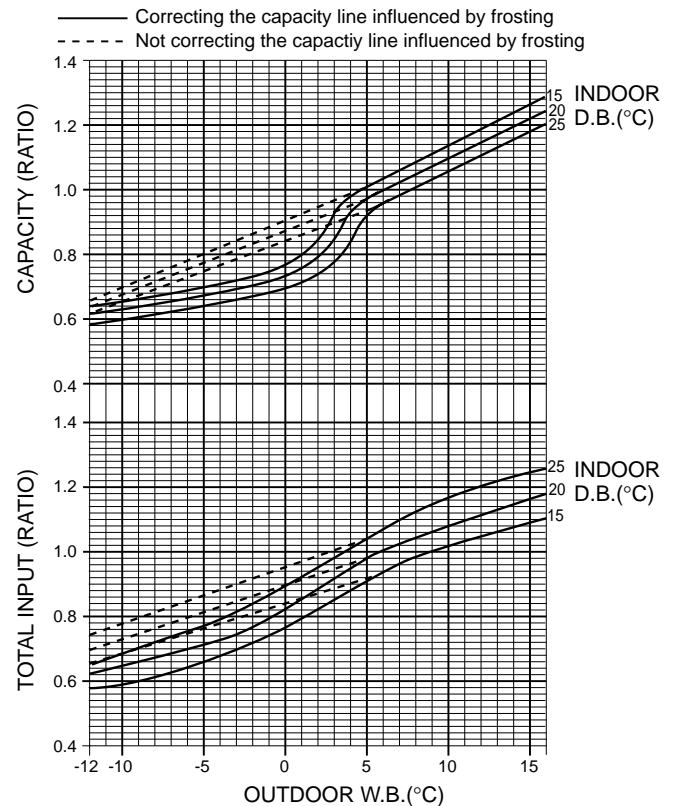

5-3. Correction factors

PKA-RP•GAL / PUHZ-RP•VHA

Cooling capacity correction factors

Service Ref.	Refrigerant piping length (one way)									
	5m	10m	20m	30m	40m	50m	55m	60m	70m	80m
PKA-RP1.6GAL	1.00	0.992	0.976	0.962	0.949	0.936	0.930	—	—	—
PKA-RP2GAL	1.00	0.985	0.957	0.931	0.908	0.886	0.876	—	—	—

Heating capacity correction factors

Service Ref.	Refrigerant piping length (one way)									
	5m	10m	20m	30m	40m	50m	55m	60m	70m	80m
PKA-RP1.6GAL	1.00	0.997	0.991	0.985	0.979	0.973	0.970	—	—	—
PKA-RP2GAL	1.00	0.997	0.991	0.985	0.979	0.973	0.970	—	—	—

PKA-RP•GAL / PUH-P•VGAA PUH-P•VGAA.UK PUH-P•YGAA.UK
 PU-P•VGAA PU-P•VGAA.UK PU-P•YGAA.UK
 PUH-P•VGAA₁.UK PUH-P•YGAA₁.UK
 PU-P•VGAA₁.UK PU-P•YGAA₁.UK

Cooling capacity correction factors

Service Ref.	Refrigerant piping length(one way)					
	5m	10m	20m	30m	40m	50m
PKA-RP1.6GAL	1.00	0.993	0.978	0.961	0.948	—
PKA-RP2GAL	1.00	0.993	0.978	0.961	0.948	—

Heating capacity correction factors

Service Ref.	Refrigerant piping length(one way)					
	5m	10m	20m	30m	40m	50m
PKA-RP1.6GAL	1.00	0.998	0.993	0.988	0.983	—
PKA-RP2GAL	1.00	0.998	0.993	0.988	0.983	—

5-4. STANDARD OPERATION DATA

Heat pump type (1)

Service Ref.			PKA-RP1.6GAL		PKA-RP2GAL		
Mode			Cooling	Heating	Cooling	Heating	
Total	Capacity	W	3,600	4,100	4,600	4,500	
	Input	kW	1.03	1.27	1.63	1.40	
Electrical circuit	Indoor unit Service Ref.		PKA-RP1.6GAL		PKA-RP2GAL		
	Phase , Hz		1 , 50		1 , 50		
	Volts		230		230		
	Amperes		0.33	0.33	0.33	0.33	
	Outdoor unit Service Ref.		PUHZ-RP1.6VHA		PUHZ-RP2VHA		
	Phase , Hz		1 , 50		1 , 50		
	Volts		230		230		
	Amperes		4.29	5.36	6.98	5.95	
Refrigerant circuit	Discharge pressure	MPa	2.68	3.05	2.89	3.18	
	Suction pressure	MPa	1.01	0.73	0.79	0.72	
	Dischahrge temperature	°C	70	81	76	82	
	Condensing temperature	°C	46	48	49	53	
	Suction temperature	°C	15	2	3	2	
	Ref.pipe length	m	5	5	5	5	
Indoor side	Intake air temperature	D.B.	°C	27	20	27	20
		W.B.	°C	19	15	19	15
	Discharge air temperature	D.B.	°C	14.8	38.3	13.3	40.2
Outdoor side	Intake air temperature	D.B.	°C	35	7	35	7
		W.B.	°C	24	6	24	6
SHF			0.84	—	0.74	—	
BF			0.11	—	0.13	—	

The unit of pressure has been changed to Mpa on the international system of unit (SI system).
The converted score against the traditional unit system can be gotten according to the formula below.
1(Mpa) = 10.2(kgf/cm²)

Heat pump type (2)

Service Ref.			PKA-RP1.6GAL				PKA-RP2GAL				
Mode			Cooling	Heating	Cooling	Heating	Cooling	Heating	Cooling	Heating	
Total	Capacity	W	4,450	4,950	4,450	4,950	5,350	6,200	5,350	6,200	
	Input	kW	1.70	1.79	1.70	1.79	2.33	2.34	2.33	2.34	
Electrical circuit	Indoor unit Service Ref.		PKA-RP1.6GAL				PKA-RP2GAL				
	Phase , Hz		1 , 50				1 , 50				
	Volts		230				230				
	Amperes		0.33	0.33	0.33	0.33	0.33	0.33	0.33	0.33	
	Outdoor unit Service Ref.		PUH-P1.6VGAA PUH-P1.6VGAA.UK PUH-P1.6VGAA.UK	PUH-P1.6YGAA.UK PUH-P1.6YGAA.UK		PUH-P2VGAA PUH-P2VGAA.UK PUH-P2VGAA.UK		PUH-P2YGAA.UK PUH-P2YGAA.UK			
	Phase , Hz		1 , 50		3 , 50		1 , 50		3 , 50		
	Volts		230		400		230		400		
	Amperes		7.79	8.22	2.37	2.51	10.80	10.85	3.37	3.39	
Refrigerant circuit	Discharge pressure	MPa	2.11	2.10	2.11	2.10	2.38	2.56	2.38	2.56	
	Suction pressure	MPa	0.53	0.47	0.53	0.47	0.48	0.44	0.48	0.44	
	Discharge temperature	°C	80	77	80	77	88	95	88	95	
	Condensing temperature	°C	49	47	49	47	53	55	53	55	
	Suction temperature	°C	8	2	8	2	4	1	4	1	
	Ref.pipe length	m	5	5	5	5	5	5	5	5	
Indoor side	Intake air temperature	D.B.	°C	27	20	27	20	27	20	27	20
		W.B.	°C	19	15	19	15	19	15	19	15
	Discharge air temperature	D.B.	°C	13.3	42.5	13.3	42.5	11.9	48.9	11.9	48.9
Outdoor side	Intake air temperature	D.B.	°C	35	7	35	7	35	7	35	7
		W.B.	°C	24	6	24	6	24	6	24	6
SHF			0.77	—	0.77	—	0.70	—	0.70	—	
BF			0.09	—	0.09	—	0.11	—	0.11	—	

The unit of pressure has been changed to Mpa on the international system of unit (SI system).
The converted score against the traditional unit system can be gotten according to the formula below.
1(Mpa) = 10.2(kgf/cm²)

Cooling only type

Service Ref.			PKA-RP1.6GAL		PKA-RP2GAL	
Mode			Cooling	Cooling	Cooling	Cooling
Total	Capacity	W	4,450	4,450	5,350	5,350
	Input	kW	1.70	1.70	2.33	2.33
Electrical circuit	Indoor unit Service Ref.		PKA-RP1.6GAL		PKA-RP2GAL	
	Phase , Hz		1 , 50		1 , 50	
	Volts		230		230	
	Amperes		0.33	0.33	0.33	0.33
	Outdoor unit Service Ref.		PU-P1.6VGAA PU-P1.6VGAA.UK PU-P1.6VGAA;.UK	PU-P1.6YGAA.UK PU-P1.6YGAA;.UK	PU-P2VGAA PU-P2VGAA.UK PU-P2VGAA;.UK	PU-P2YGAA.UK PU-P2YGAA;.UK
	Phase , Hz		1 , 50	3 , 50	1 , 50	3 , 50
	Volts		230	400	230	400
	Amperes		7.79	2.37	10.80	3.37
Refrigerant circuit	Discharge pressure	MPa	2.11	2.11	2.38	2.38
	Suction pressure	MPa	0.53	0.53	0.48	0.48
	Discharge temperature	°C	80	80	88	88
	Condensing temperature	°C	49	49	53	53
	Suction temperature	°C	8	8	4	4
	Ref.pipe length	m	5	5	5	5
Indoor side	Intake air temperature	D.B.	°C	27	27	27
		W.B.	°C	19	19	19
	Discharge air temperature	D.B.	°C	13.3	13.3	11.9
Outdoor side	Intake air temperature	D.B.	°C	35	35	35
		W.B.	°C	24	24	24
SHF			0.77	0.77	0.70	0.70
BF			0.09	0.09	0.11	0.11

The unit of pressure has been changed to Mpa on the international system of unit (SI system).
The converted score against the traditional unit system can be gotten according to the formula below.
 $1(\text{Mpa}) = 10.2(\text{kgf/cm}^2)$

5-5. OUTLET AIR SPEED COVERAGE RANGE

	PKA-RP1.6GAL	PKA-RP2GAL
Air flow m ³ /min	12	12
Air speed m/sec	5.3	5.3
Coverage range m (ft)	10(32.8)	10(32.8)

The air coverage range is the value up to the position where the air speed is 0.25m/sec. when air is blown out horizontally from the unit at the Hi notch position.

The coverage range should be used only as a general guideline since it varies according to the size of the room and the furniture inside the room.

5-6. NOISE CRITERION CURVES

PKA-RP1.6GAL
PKA-RP2GAL

NOTCH	SPL(dB)	LINE
Hi	43	○—○
Mi1	41	△—△
Mi2	38	●—●
Lo	36	▲—▲

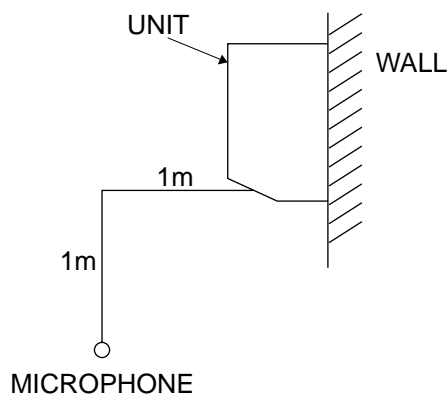
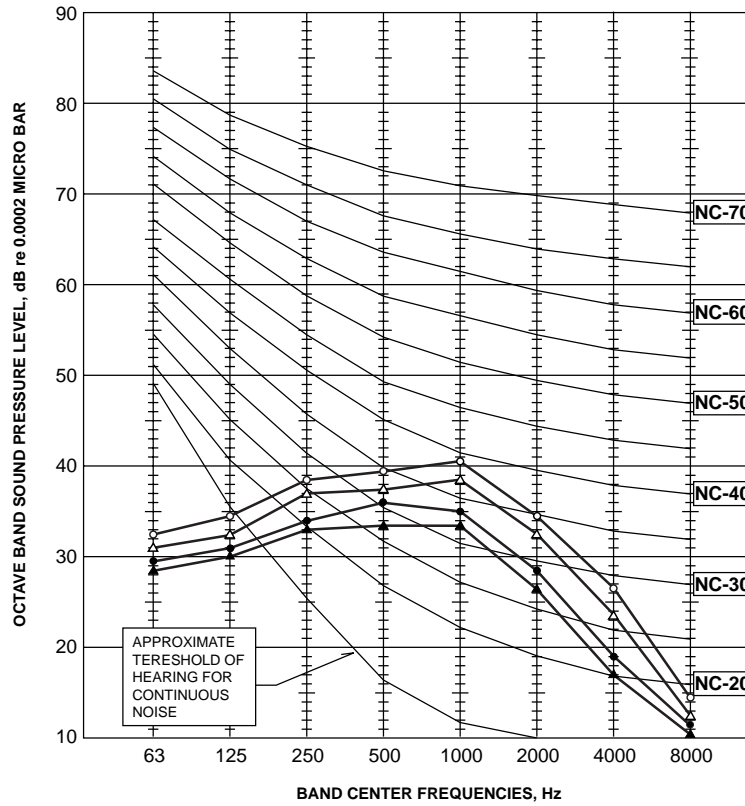

INDOOR UNIT
PKA-RP1.6GAL
PKA-RP2GAL

Unit : mm

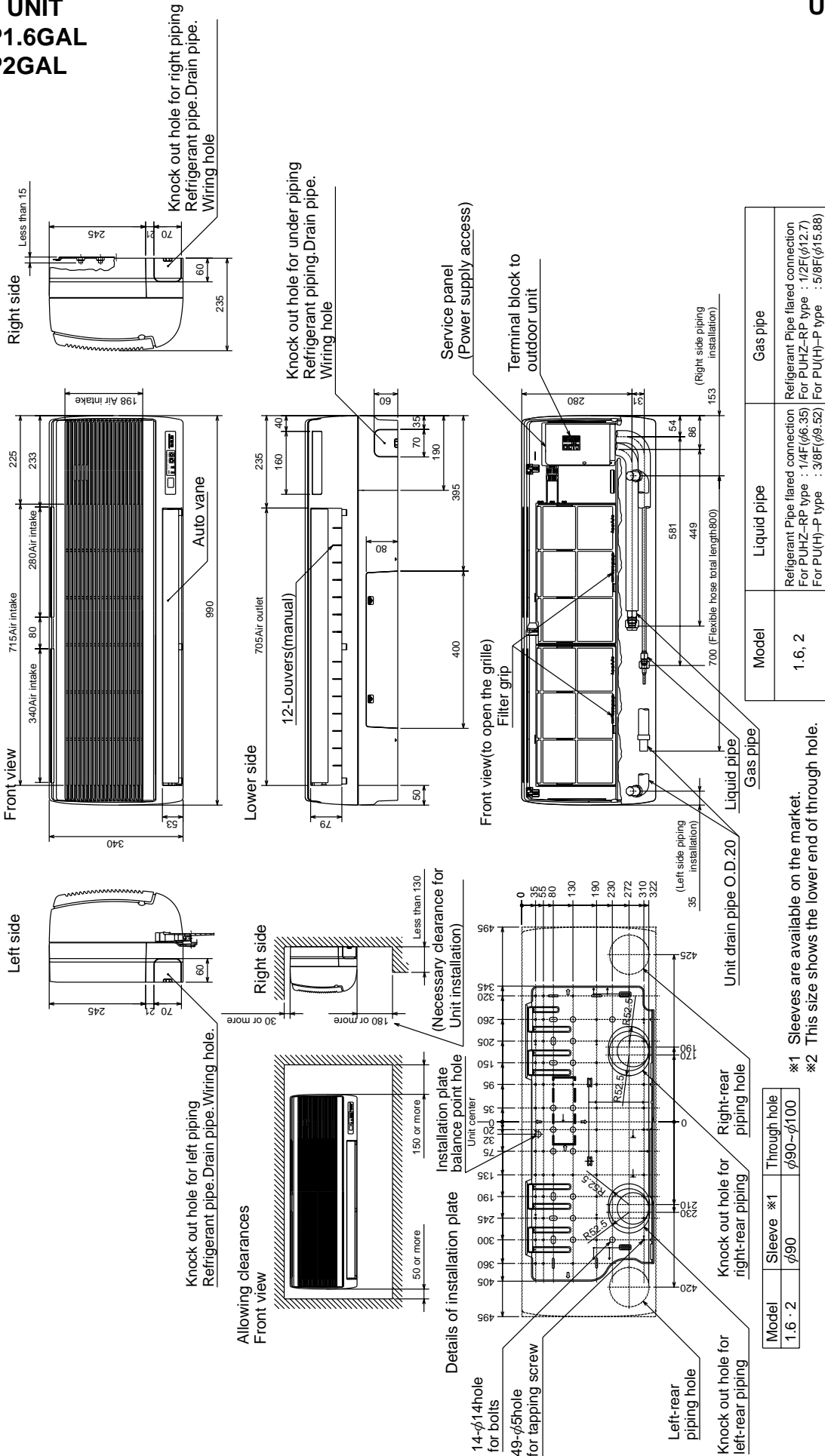

7

WIRING DIAGRAM

PKA-RP1.6GAL PKA-RP2GAL

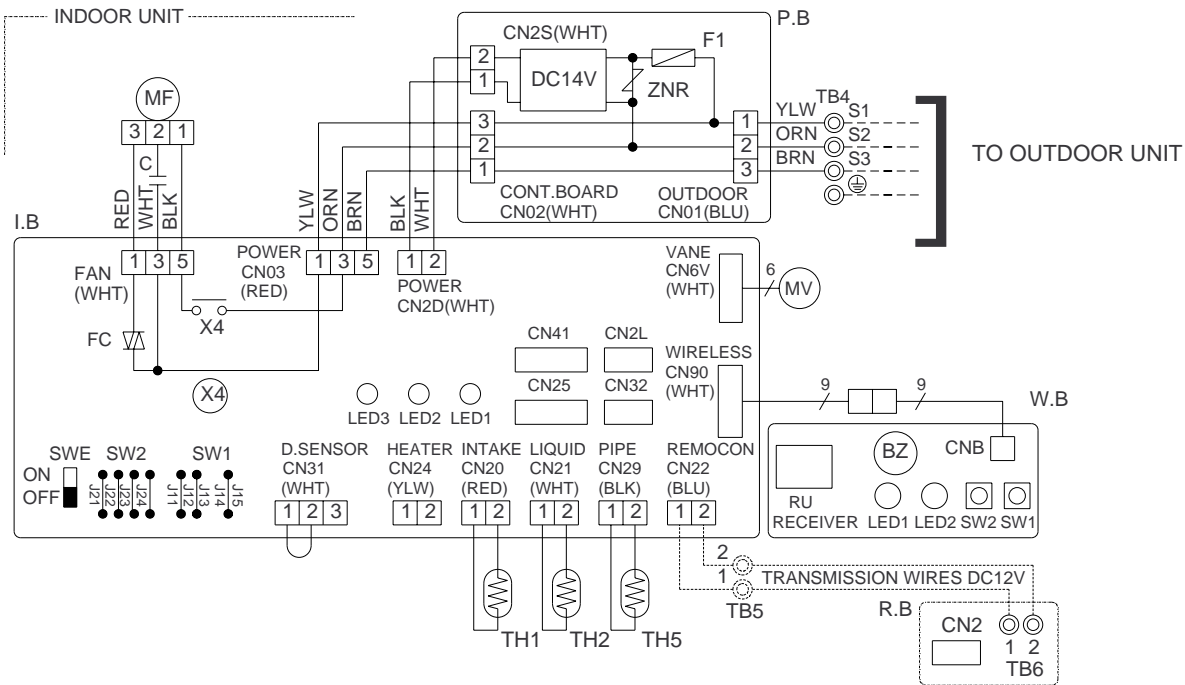

Please set the voltage using the remote controller.
For the setting method, please refer to the indoor unit Installation Manual.

SW1		MODELS	SW2		MODELS	SW2	
Manufacture	Service board		Manufacture	Service board		Manufacture	Service board
J11 J12 J13 J14 J15	1 2 3 4 5 ON OFF	1.6GAL	J21 J22 J23 J24	1 2 3 4 ON OFF	2GAL	J21 J22 J23 J24	1 2 3 4 ON OFF

SYMBOL	NAME	SYMBOL	NAME	SYMBOL	NAME
P.B	INDOOR POWER BOARD	C	CAPACITOR(FAN MOTOR)	W.B	WIRELESS REMOTE CONTROLLER BOARD
F1	FUSE(4A)	MF	FAN MOTOR	RU	RECEIVING UNIT
ZNR	VARISTOR	MV	VANE MOTOR	BZ	BUZZER
I.B	INDOOR CONTROLLER BOARD	TB4	TERMINAL BLOCK(INDOOR/OUTDOOR CONNECTING LINE)	LED1	LED(RUN INDICATOR)
CN2L	CONNECTOR(LOSSNAY)	TB5	TERMINAL BLOCK(REMOTE CONTROLLER TRANSMISSION LINE)(OPTION)	LED2	LED(HOT ADJUST)
CN32	CONNECTOR(REMOTE SWITCH)	TH1	ROOM TEMP.THERMISTOR (0°C/15kΩ,25°C/5.4kΩ DETECT)	SW1	SWITCH(HEATING ON/OFF)
CN41	CONNECTOR(HA TERMINAL-A)	TH2	PIPE TEMP.THERMISTOR/LIQUID (0°C/15kΩ,25°C/5.4kΩ DETECT)	SW2	SWITCH(COOLING ON/OFF)
SW1	JUMPER WIRE(MODEL SELECTION)	TH5	COND./EVA.TEMP.THERMISTOR (0°C/15kΩ,25°C/5.4kΩ DETECT)	R.B	REMOTE CONTROLLER BOARD(OPTION)
SW2	JUMPER WIRE(CAPACITY CORD)			CN2	CONNECTOR(PROGRAM TIMER)
SWE	SWITCH(EMERGENCY OPERATION)			TB6	TERMINAL BLOCK(REMOTE CONTROLLER TRANSMISSION LINE)
X4	RELAY(FAN MOTOR)				
FC	FAN PHASE CONTROL				
LED1	POWER SUPPLY(I.B)				
LED2	POWER SUPPLY(R.B)				
LED3	TRANSMISSION(INDOOR-OUTDOOR)				

NOTES:

- Since the outdoor side electric wiring may change be sure to check the outdoor unit electric wiring for servicing.
- Indoor and outdoor connecting wires are made with polarities, make wiring matching terminal numbers(S1, S2, S3).
- Make sure that the main power supply of the booster heater is independent.
- Symbols used in wiring diagram above are, □□□ :Connector, ⊙ :Terminal (block).

[Self-diagnosis]

An explanation of the wireless remote controller self checking operations, check codes, buzzer sounds and LED signals are given below. For check codes and symptom see the table below please.

- Press the **CHECK** button twice continuously.
 - CHECK** begins to light and refrigerant address display "00" begins to blink.
 - Start this operation from the status of remote controller display turned off.
- Press the **TEMP** buttons.
 - Set the refrigerant address of the indoor unit that is to be self-diagnosed.
 - Set the refrigerant address of outdoor unit by outdoor unit dip switch "SW1". (Refer to installation manual of outdoor unit for the detail.)
- While pointing the remote controller toward the unit's receiver, press the **(h)** button.
 - The check code will be indicated by the number of times that the buzzer sounds from the receiver section and the number of blinks of the operation lamp.
- While pointing the remote controller toward the unit's receiver, press the **ON/OFF** button.
 - Self-check mode is canceled.

Check code	Operation lamp	Buzzer sound	Symptom
P1	1SEC.FLASH×1	Single beep×1	Abnormality of room temperature thermistor(TH1).
P2	1SEC.FLASH×2	Single beep×2	Abnormality of pipe temperature thermistor/Liquid(TH2).
P6	1SEC.FLASH×6	Single beep×6	Freezing /overheating protection is working.
P8	1SEC.FLASH×8	Single beep×8	Abnormality of pipe temperature.
P9	1SEC.FLASH×2	Single beep×2	Abnormality of pipe temperature thermistor/ Cond./Eva.(TH5).
U0-UL	(0.4+0.4)SEC.FLASH×1	Double beep×1	Abnormality in outdoor unit. Refer to outdoor unit wiring diagram.
F1-F9			
E6-EF	DIFFERENT FROM ABOVE	Sounds other than above	Abnormality of signal transmission between indoor unit and outdoor unit ("EE" indicates abnormality of combination).
----	OFF	No sound	No trouble generated in the past.
FFFF	OFF	Triple beep	No corresponding unit.

PKA-RP1.6GAL
 PKA-RP2GAL

Unit : mm

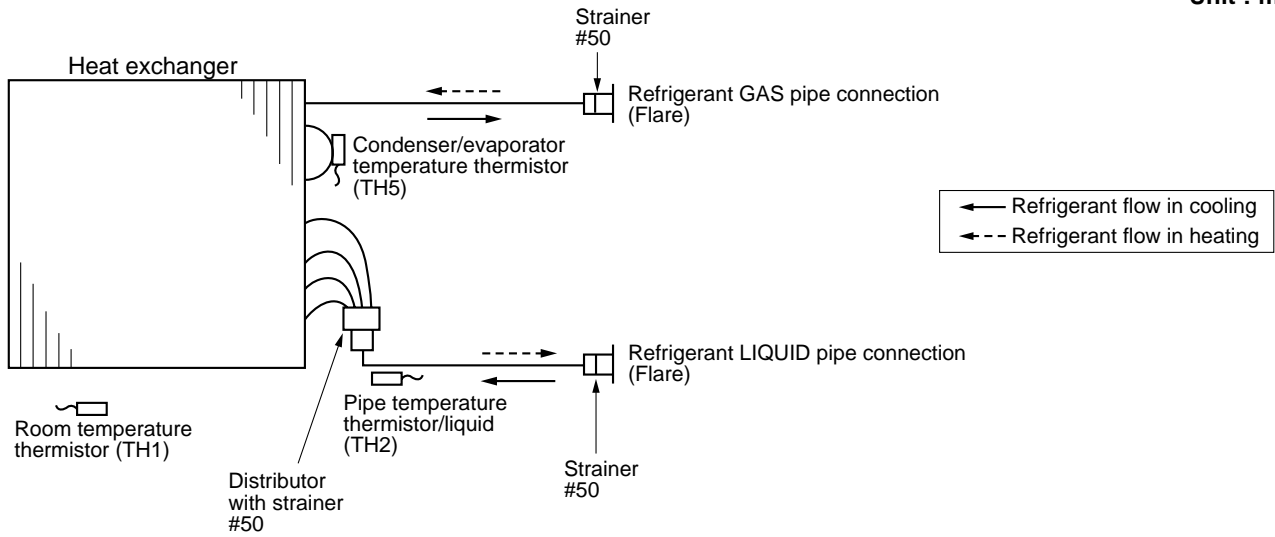

9-1. TROUBLESHOOTING

<Error code display by self-diagnosis and actions to be taken for service (summary)>

Present and past error codes are logged and displayed on the wired remote controller or controller board of outdoor unit. Actions to be taken for service and the inferior phenomenon reoccurrence at field are summarized in the table below. Check the contents below before investigating details.

Unit conditions at service	Error code	Actions to be taken for service (summary)
The inferior phenomenon is reoccurring.	Displayed	Judge what is wrong and take a corrective action according to "Self-diagnosis action table" (Page 31).
	Not displayed	Identify the cause of the inferior phenomenon and take a corrective action according to "Trouble shooting by inferior phenomena" (Page 34).
The inferior phenomenon is not reoccurring.	Logged	<ul style="list-style-type: none"> ① Consider the temporary defects such as the work of protection devices in the refrigerant circuit including compressor, poor connection of wiring, noise and etc. Re-check the symptom, and check the installation environment, refrigerant amount, weather when the inferior phenomenon occurred, and wiring related. ② Reset error code logs and restart the unit after finishing service. ③ There is no abnormality in electrical components, controller boards, and remote controller.
	Not logged	<ul style="list-style-type: none"> ① Recheck the abnormal symptom. ② Identify the cause of the inferior phenomenon and take a corrective action according to "Trouble shooting by inferior phenomena" (Page 34). ③ Continue to operate unit for the time being if the cause is not ascertained. ④ There is no abnormality in electrical components, controller boards, remote controller etc.

9-2. Malfunction-diagnosis method by remote controller

<In case of trouble during operation>

When a malfunction occurs to air conditioner, both indoor unit and outdoor unit will stop and operation lamp blinks to inform unusual stop.

<Malfunction-diagnosis method at maintenance service>

[Procedure]

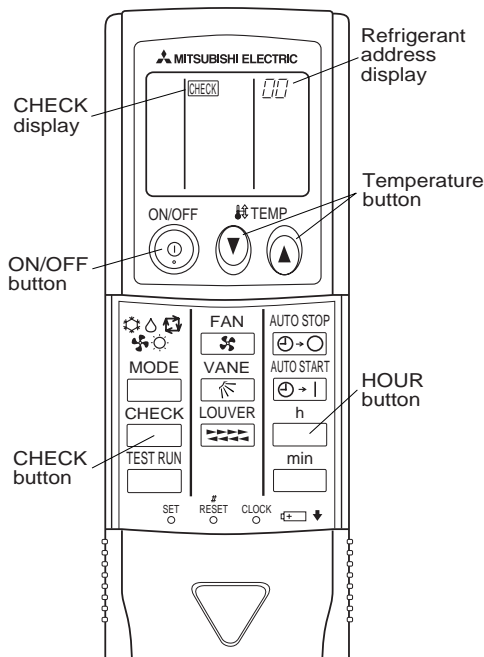

1. Press the CHECK button twice.
 - "CHECK" lights, and refrigerant address "00" flashes.
 - Check that the remote controller's display has stopped before continuing.
2. Press the temperature \downarrow \uparrow buttons.
 - Select the refrigerant address of the indoor unit for the self-diagnosis.
 - Note: Set refrigerant address using the outdoor unit's DIP switch (SW1). (For more information, see the outdoor unit installation manual.)
3. Point the remote controller at the sensor on the indoor unit and press the HOUR button.
 - If an air conditioner error occurs, the indoor unit's sensor emits an intermittent buzzer sound, the operation light flashes, and the error code is output. (It takes 3 seconds at most for error code to appear.)
4. Point the remote controller at the sensor on the indoor unit and press the ON/OFF button.
 - The check mode is cancelled.

* Malfunction diagnosis can be performed only for refrigerant system controlling wireless units.

Inspected unit	Check code	Beep output	Operation LED	Inspected unit	Check code	Beep output	Operation LED
Indoor unit	P1	beep × 1 time	1 sec. × 1 time	Outdoor unit	F1–F9	beep beep × 1 time	(0.4sec+0.4sec) × 1 time
	P2	beep × 2 times	1 sec. × 2 times		U0–UP		
	P4	beep × 4 times	1 sec. × 4 times		E6–EE	Other than above	Other than above
	P5	beep × 5 times	1 sec. × 5 times	—	No check code (normal)	No output	Lights off
	P6	beep × 6 times	1 sec. × 6 times		No check code (mistake of matching with refrigerant address)	beep beep beep	Lights off
	P8	beep × 8 times	1 sec. × 8 times				
	P9	beep × 2 times	1 sec. × 2 times				
E4, E5	Other than above	Other than above					

Note: Refer to the manual of outdoor unit for the details of display such as F, U, and other E.

9-3. SELF-DIAGNOSIS ACTION TABLE

Error Code	Meaning of error code and detection method	Cause	Countermeasure
P1	<p>Abnormality of room temperature thermistor (TH1)</p> <p>① The unit is in three-minute resume prevention mode if short/open of thermistor is detected. Abnormal if the unit does not reset normally after three minutes. (The unit returns to normal operation, if it has normally reset.)</p> <p>② Constantly detected during cooling, drying, and heating operation. Short: 90°C or more Open: -40°C or less</p>	<p>① Defective thermistor characteristics.</p> <p>② Contact failure of connector (CN20) on the indoor controller board. (Insert failure)</p> <p>③ Breaking of wire or contact failure of thermistor wiring.</p> <p>④ Defective indoor controller board.</p>	<p>①-③ Check resistance value of thermistor. 0°C15.0kΩ 10°C9.6kΩ 20°C6.3kΩ 30°C4.3kΩ 40°C3.0kΩ</p> <p>If you put force on (draw or bend) the lead wire with measuring resistance value of thermistor breaking of wire or contact failure can be detected.</p> <p>② Check contact failure of connector (CN20) on the indoor controller board. Refer to page 37. Turn the power on again and check restart after inserting connector again.</p> <p>④ Check room temperature display on remote controller. Replace indoor controller board if there is abnormal difference with actual room temperature.</p> <p>Turn the power off, and on again to operate after check.</p>
P2	<p>Abnormality of pipe temperature thermistor/Liquid (TH2)</p> <p>① The unit is in three-minute resume prevention mode if short/open of thermistor is detected. Abnormal if the unit does not reset normally after three minutes. (The unit returns to normal operation, if it has normally reset.)</p> <p>② Constantly detected during cooling, drying, and heating (except defrosting) operation. Short: 90°C or more Open: -40°C or less</p>	<p>① Defective thermistor characteristics.</p> <p>② Contact failure of connector (CN21) on the indoor controller board. (Insert failure)</p> <p>③ Breaking of wire or contact failure of thermistor wiring.</p> <p>④ Defective refrigerant circuit is causing thermistor temperature of 90°C or more or -40°C or less.</p> <p>⑤ Defective indoor controller board.</p>	<p>①-③ Check resistance value of thermistor. For characteristics, refer to (P1) above.</p> <p>② Check contact failure of connector (CN21) on the indoor controller board. Refer to page 37. Turn the power on and check restart after inserting connector again.</p> <p>④ Check pipe <liquid> temperature with remote controller in test run mode. If pipe <liquid> temperature is exclusively low (in cooling mode) or high (in heating mode), refrigerant circuit may have defective.</p> <p>⑤ Check pipe <liquid> temperature with remote controller in test run mode. If there is exclusive difference with actual pipe <liquid> temperature, replace indoor controller board.</p> <p>Turn the power off, and on again to operate after check.</p>
P4	<p>Abnormality of drain sensor (DS)</p> <p>① Suspensive abnormality, if short/open of thermistor is detected for 30 seconds continuously. Turn off compressor and indoor fan.</p> <p>② Short/open is detected for 30 seconds continuously during suspensive abnormality. (The unit returns to normal operation, if it has normally reset.)</p> <p>③ Detect the following condition.</p> <ul style="list-style-type: none"> • During cooling and drying operation. • In case that pipe <liquid> temperature - room temperature <-10deg (Except defrosting) • When pipe <liquid> temperature or room temperature is short/open temperature. • During drain pump operation. 	<p>① Defective thermistor characteristics</p> <p>② Contact failure of connector (CN31) on the indoor controller board. (Insert failure).</p> <p>③ Breaking of wire or contact failure of drain sensor wiring.</p> <p>④ Defective indoor controller board.</p>	<p>①-③ Check resistance value of thermistor. 0°C6.0kΩ 10°C3.9kΩ 20°C2.6kΩ 30°C1.8kΩ 40°C1.3kΩ</p> <p>② Check contact failure of connector (CN31) on the indoor controller board. Refer to page 37. Turn the power on again and check restart after inserting connector again.</p> <p>④ Replace indoor controller board if drain pump operates with the line of drain sensor connector CN31-① and ② is short-circuited, and abnormality reappears.</p> <p>Turn the power off, and on again to operate after check.</p>
P5	<p>Malfunction of drain pump (DP)</p> <p>① Suspensive abnormality, if thermistor of drain sensor is let heat itself and temperature rises slightly. Turn off compressor and indoor fan.</p> <p>② Drain pump is abnormal if the condition above is detected during suspensive abnormality.</p> <p>③ Constantly detected during drain pump operation.</p>	<p>① Malfunction of drain pump</p> <p>② Defective drain Clogged drain pump Clogged drain pipe</p> <p>③ Attached drop of water at the drain sensor</p> <ul style="list-style-type: none"> • Drops of drain trickles from lead wire. • Clogged filter is causing wave of drain. <p>④ Defective indoor controller board.</p>	<p>① Check if drain-up machine works.</p> <p>② Check drain function.</p> <p>③ Check the setting of lead wire of drain sensor and check clogs of the filter.</p> <p>④ Replace indoor controller board if drain pump operates with the line of drain sensor connector CN31-① and ② is short-circuited and abnormality reappears. Refer to page 37.</p> <p>Turn the power off, and on again to operate after check.</p>



Error Code	Meaning of error code and detection method	Cause	Countermeasure
P6	<p>Freezing/overheating protection is working</p> <p>① Freezing protection (Cooling mode) The unit is in six-minute resume prevention mode if pipe <liquid or condenser/evaporator> temperature stays under -15°C for three minutes, three minutes after the compressor started. Abnormal if it stays under -15°C for three minutes again within 16 minutes after six-minute resume prevention mode.</p> <p>② Frost abnormality (Only for the combination with inverter-type outdoor unit) Suspensive abnormal if unit operates in frost prevention mode (below) for 9 minutes or more. After that, when frost prevention mode is released and compressor restarts its operation, unit is not detected as abnormal if compressor keeps operating for 20 minutes continuously and abnormal if compressor stops operating within 20 minutes and unit operates in frost prevention mode for more than 9 minutes again. (Not abnormal if unit stops operating in frost prevention mode within 9 minutes) <Frost prevention mode> If pipe <liquid or condenser-evaporator> temperature is 2°C or below when 16 minutes has passed after compressor starts operating, unit will start operating in frost prevention mode which stops compressor operation. After that, when pipe <liquid or condenser/evaporator> temperature stays 10°C or more for 3 minutes, frost prevention mode will be released and compressor will restart its operation.</p> <p>③ Overheating protection (Heating mode) The units is in six-minute resume prevention mode if pipe <condenser / evaporator> temperature is detected as over 74°C after the compressor started. Abnormal if the temperature of over 74°C is detected again within 10 minutes after six-minute resume prevention mode.</p>	<p>(Cooling or drying mode)</p> <p>① Clogged filter (reduced airflow) ② Short cycle of air path ③ Low-load (low temperature) operation beyond the tolerance range ④ Defective indoor fan motor • Fan motor is defective. • Indoor controller board is defective.</p> <p>⑤ Overcharge of refrigerant ⑥ Defective refrigerant circuit (clogs)</p> <p>(Heating mode)</p> <p>① Clogged filter (reduced airflow) ② Short cycle of air path ③ Over-load (high temperature) operation beyond the tolerance range ④ Defective indoor fan motor • Fan motor is defective. • Indoor controller board is defective.</p> <p>⑤ Overcharge of refrigerant ⑥ Defective refrigerant circuit (clogs) ⑦ Bypass circuit of outdoor unit is defective.</p>	<p>(Cooling or drying mode)</p> <p>① Check clogs of the filter. ② Remove shields.</p> <p>④ Measure the resistance of fan motor's winding. Measure the output voltage of fan's connector (FAN) on the indoor controller board. *The indoor controller board should be normal when voltage of AC 220~240V is detected while fan motor is connected. Refer to page 37.</p> <p>⑤⑥ Check operating condition of refrigerant circuit.</p> <p>(Heating mode)</p> <p>① Check clogs of the filter. ② Remove shields.</p> <p>④ Measure the resistance of fan motor's winding. Measure the output voltage of fan's connector (FAN) on the indoor controller board. *The indoor controller board should be normal when voltage of AC 220~240V is detected while fan motor is connected. Refer to page 37.</p> <p>⑤~⑦ Check operating condition of refrigerant circuit.</p>
P8	<p>Abnormality of pipe temperature <Cooling mode> Detected as abnormal when the pipe temperature is not in the cooling range 3 minutes later of compressor start and 6 minutes later of the liquid or condenser/evaporator pipe is out of cooling range. Note 1) It takes at least 9 min. to detect. Note 2) Abnormality P8 is not detected in drying mode. Cooling range : Indoor pipe temperature (TH2 or TH5) – intake temperature (TH1) \leq -3 deg TH: Lower temperature between: liquid pipe temperature and condenser/evaporator temperature</p> <p><Heating mode> When 10 seconds have passed after the compressor starts operation and the hot adjustment mode has finished, the unit is detected as abnormal when condenser/evaporator pipe temperature is not in heating range within 20 minutes.</p> <p>Note 3) It takes at least 27 minutes to detect abnormality. Note 4) It excludes the period of defrosting (Detection restarts when defrosting mode is over) Heating range : 3 deg \leq (Condenser/ Evaporator temperature(TH5) – intake temperature(TH1))</p>	<p>① Slight temperature difference between indoor room temperature and pipe <liquid or condenser / evaporator> temperature thermistor • Shortage of refrigerant • Disconnected holder of pipe <liquid or condenser / evaporator> thermistor • Defective refrigerant circuit</p> <p>② Converse connection of extension pipe (on plural units connection)</p> <p>③ Converse wiring of indoor/outdoor unit connecting wire (on plural units connection)</p> <p>④ Defective detection of indoor room temperature and pipe <condenser / evaporator> temperature thermistor</p> <p>⑤ Stop valve is not opened completely.</p>	<p>①~④ Check pipe <liquid or condenser / evaporator> temperature with room temperature display on remote controller and outdoor controller circuit board. Pipe <liquid or condenser / evaporator> temperature display is indicated by setting SW2 of outdoor controller circuit board as follows.</p> <p>(Conduct temperature check with outdoor controller circuit board after connecting 'A-Control Service Tool(PAC-SK52ST)').</p> <div style="display: flex; justify-content: space-around;"> <div style="text-align: center;"> <p>Temperature display of indoor liquid pipe Indoor 1</p> </div> <div style="text-align: center;"> <p>Temperature display of indoor condensers/ evaporator pipe Indoor 1</p> </div> </div> <div style="display: flex; justify-content: space-around; margin-top: 10px;"> <div style="text-align: center;"> <p>Temperature display of indoor liquid pipe Indoor 2</p> </div> <div style="text-align: center;"> <p>Temperature display of indoor condensers/ evaporator pipe Indoor 2</p> </div> </div> <p style="text-align: center; font-size: small;">A-Control Service Tool SW2 setting</p> <p>②③ Check converse connection of extension pipe or converse wiring of indoor/outdoor unit connecting wire.</p>



Error Code	Meaning of error code and detection method	Cause	Countermeasure
P9	<p>Abnormality of pipe temperature thermistor / Condenser-Evaporator (TH5)</p> <p>① The unit is in three-minute resume protection mode if short/open of thermistor is detected. Abnormal if the unit does not get back to normal within three minutes. (The unit returns to normal operation, if it has normally reset.)</p> <p>② Constantly detected during cooling, drying, and heating operation (except defrosting) Short: 90°C or more Open: -40°C or less</p>	<p>① Defective thermistor characteristics</p> <p>② Contact failure of connector (CN29) on the indoor controller board. (Insert failure)</p> <p>③ Breaking of wire or contact failure of thermistor wiring.</p> <p>④ Temperature of thermistor is 90°C or more or -40°C or less caused by defective refrigerant circuit.</p> <p>⑤ Defective indoor controller board.</p>	<p>①-③ Check resistance value of thermistor. For characteristics, refer to (P1) above.</p> <p>② Check contact failure of connector (CN29) on the indoor controller board. Refer to page 37. Turn the power on and check restart after inserting connector again.</p> <p>④ Operate in test run mode and check pipe <condenser / evaporator> temperature with outdoor controller circuit board. If pipe <condenser / evaporator> temperature is exclusively low (in cooling mode) or high (in heating mode), refrigerant circuit may have defective.</p> <p>⑤ Operate in test run mode and check pipe <condenser / evaporator> temperature with outdoor control circuit board. If there is exclusive difference with actual pipe <condenser / evaporator> temperature replace indoor controller board. There is no abnormality if none of above comes within the unit. Turn the power off and on again to operate.</p> <p>(In case of checking pipe temperature with outdoor controller circuit board, be sure to connect A-control service tool (PAC-SK52ST).)</p> <div style="display: flex; justify-content: space-around;"> <div style="text-align: center;"> <p>Temperature display of indoor condenser/ evaporator pipe Indoor 1</p> </div> <div style="text-align: center;"> <p>Temperature display of indoor condenser/ evaporator pipe Indoor 2</p> </div> </div> <p style="text-align: center; font-size: small;">A-Control Service Tool SW2 setting</p>
E4	<p>Remote controller signal receiving error</p> <p>① Abnormal if indoor controller board can not receive normally any data from remote controller or from other indoor controller board for three minutes.</p> <p>② Indoor control board cannot receive any signal from remote controller for two minutes.</p>	<p>① Contact failure at transmission wire of remote controller</p> <p>② All remote controllers are set as "sub" remote controller. In this case, E0 is displayed on remote controller, and E4 is displayed at LED (LED1, LED2) on the outdoor controller circuit board.</p> <p>③ Defective transmitting receiving circuit of remote controller</p> <p>④ Defective transmitting receiving circuit of indoor controller board.</p> <p>⑤ Noise has entered into the transmission wire of remote controller.</p>	<p>① Check disconnection or looseness of indoor unit or transmission wire of remote controller.</p> <p>② Set one of the remote controllers "main". If there is no problem with the action above.</p> <p>③ Diagnose remote controllers.</p> <p>a) When "RC OK" is displayed, Remote controllers have no problem. Put the power off, and on again to check. If abnormality generates again, replace indoor controller board.</p> <p>b) When "RC NG" is displayed, Replace remote controller.</p> <p>c) When "RC E3" is displayed,</p> <p>d) When "ERC 00-06" is displayed, [c),d)→Noise may be causing abnormality.]</p> <p>* If the unit is not normal after replacing indoor controller board in group control, indoor controller board of address "0" may be abnormal.</p>
E5	<p>Remote controller transmitting error</p> <p>① Abnormal if indoor controller board cannot check the blank of transmission path for three minutes.</p> <p>② Abnormal if indoor controller board cannot finish transmitting 30 times consecutively.</p>	<p>① Defective transmitting receiving circuit of indoor controller board.</p> <p>② Noise has entered into the transmission wire of remote controller.</p>	<p>①② Turn the power off, and on again to check. If abnormality generates again, replace indoor controller board.</p>
E6	<p>Indoor/outdoor unit communication error (Signal receiving error)</p> <p>① Abnormal if indoor controller board cannot receive any signal normally for six minutes after putting the power on.</p> <p>② Abnormal if indoor controller board cannot receive any signal normally for three minutes.</p> <p>③ Consider the unit abnormal under the following condition: When two or more indoor units are connected to one outdoor unit, indoor controller board cannot receive a signal for three minutes from outdoor controller circuit board, a signal which allows outdoor controller circuit board to transmit signals.</p>	<p>① Contact failure, short circuit or, mis-wiring (converse wiring) of indoor/outdoor unit connecting wire</p> <p>② Defective transmitting receiving circuit of indoor controller board</p> <p>③ Defective transmitting receiving circuit of indoor controller board</p> <p>④ Noise has entered into indoor/ outdoor unit connecting wire.</p>	<p>* Check LED display on the outdoor control circuit board. (Connect A-control service tool, PAC-SK52ST.) Refer to EA-EC item if LED displays EA-EC.</p> <p>① Check disconnection or looseness of indoor/ outdoor unit connecting wire of indoor unit or outdoor unit. Check all the units in case of twin triple indoor unit system.</p> <p>②-④ Turn the power off, and on again to check. If abnormality generates again, replace indoor controller board or outdoor controller circuit board.</p> <p>* Other indoor controller board may have defective in case of twin triple indoor unit system.</p>
E7	<p>Indoor/outdoor unit communication error (Transmitting error)</p> <p>Abnormal if "1" receiving is detected 30 times continuously though indoor controller board has transmitted "0".</p>	<p>① Defective transmitting receiving circuit of indoor controller board</p> <p>② Noise has entered into power supply.</p> <p>③ Noise has entered into outdoor control wire.</p>	<p>①-③ Turn the power off, and on again to check. If abnormality generates again, replace indoor controller board.</p>



9-4. TROUBLESHOOTING BY INFERIOR PHENOMENA

Note: Refer to the manual of outdoor unit for the detail of remote controller.

Phenomena	Cause	Countermeasure
(1)LED2 on indoor controller board is off.	<ul style="list-style-type: none"> • When LED1 on indoor controller board is also off. <p>① Power supply of 220~240V is not supplied to outdoor unit.</p> <p>② Defective outdoor controller circuit board.</p> <p>③ Power supply of 220~240V is not supplied to indoor unit.</p> <p>④ Defective indoor power board.</p> <p>⑤ Defective indoor controller board.</p>	<p>① Check the voltage of outdoor power supply terminal block (L, N)</p> <ul style="list-style-type: none"> • When AC 220~240V is not detected. Check the power wiring to outdoor unit and the breaker. • When AC 220~240V is detected. —Check ② (below). <p>② Check the voltage between outdoor terminal block S1 and S2.</p> <ul style="list-style-type: none"> • When AC 220~240V is not detected. Check the fuse on outdoor controller circuit board (10A). Check the wiring connection. • When AC 220~240V is detected. —Check ③ (below). <p>③ Check the voltage between indoor terminal block S1 and S2.</p> <ul style="list-style-type: none"> • When AC 220~240V is not detected. Check indoor/outdoor unit connecting wire for mis-wiring. • When AC 220~240V is detected. —Check ④ (below). <p>④ Check voltage output from CN2S on indoor power board (DC14V). Refer to page 38.</p> <ul style="list-style-type: none"> • When no voltage is output. Check the fuse on indoor power board. Check the wiring connection. • When output voltage is between 12V and 16V. —Check ⑤ (below). <p>⑤ Check the wiring connection between indoor controller board and indoor power board. If no problems are found, indoor controller board is defective.</p>
	<ul style="list-style-type: none"> • When LED1 on indoor controller board is lit. <p>① Mis-setting of refrigerant address for outdoor unit (There is no unit corresponding to refrigerant address "0".)</p>	<p>① Reconfirm the setting of refrigerant address for outdoor unit Set the refrigerant address to "0". (For grouping control system under which 2 or more outdoor units are connected, set one of the units to "0".) Set refrigerant address using SW1 (3-6) on outdoor controller circuit board.</p>
(2)LED2 on indoor controller board is blinking.	<ul style="list-style-type: none"> • When LED1 on indoor controller board is also blinking. Connection failure of indoor/outdoor unit connecting wire • When LED1 is lit. Mis-wiring of remote controller wires Under twin triple indoor unit system, 2 or more indoor units are wired together. <p>① Refrigerant address for outdoor unit is wrong or not set. Under grouping control system, there are some units whose refrigerant address is 0.</p> <p>② Short-cut of remote controller wires</p> <p>③ Defective remote controller</p>	<p>Check indoor/outdoor unit connecting wire for connection failure. Check the connection of remote controller wires in case of twin triple indoor unit system. When 2 or more indoor units are wired in one refrigerant system, connect remote controller wires to one of those units.</p> <p>① Check the setting of refrigerant address in case of grouping control system. If there are some units whose refrigerant addresses are 0 in one group, set one of the units to 0 using SW1 (3-6) on outdoor controller circuit board.</p> <p>②③ Remove remote controller wires and check LED2 on indoor controller board.</p> <ul style="list-style-type: none"> • When LED2 is blinking, check the short-cut of remote controller wires. • When LED2 is lit, connect remote controller wires again and: if LED2 is blinking, remote controller is defective; if LED2 is lit, connection failure of remote controller terminal block etc. has returned to normal.
(3)Upward/downward vane performance failure	<p>① The vane is not downward during defrosting and heat preparation and when the thermostat is OFF in HEAT mode. (Working of COOL protection function)</p> <p>② Vane motor does not rotate.</p> <ul style="list-style-type: none"> • Defective vane motor • Breaking of wire or connection failure of connector <p>③ Upward/downward vane does not work.</p> <ul style="list-style-type: none"> • The vane is set to fixed position. 	<p>① Normal operation (The vane is set to horizontal regardless of remote control.)</p> <p>② Check ② (left).</p> <ul style="list-style-type: none"> • Check the vane motor. (Refer to "How to check the parts".) • Check for breaking of wire or connection failure of connector. <p>③ Normal operation (Each connector on vane motor side is disconnected.)</p>

9-5. EMERGENCY OPERATION

9-5-1. When wireless remote controller troubles or its battery is exhausted

- Emergency operation is available in such a case using emergency operation switch equipped next to the receiver of indoor unit.
 - To start operation
 - Cooling Operation.....Press  (Cooling) switch.
 - Heating Operation.....Press  (Heating) switch.
- ※When the unit starts operating, the power lamp is lit.

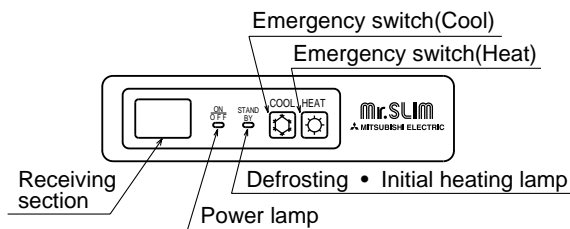

※Emergency operation will be performed as follows.

Mode	Cooling	Heating
Set temperature	24°C	24°C
Fan speed	High	High
Airflow direction	Horizontal (30deg)	Downward (70deg)

- To stop operation
 - Press either emergency operation switch (cooling/heating).

9-5-2. When wired remote controller or indoor unit micro computer troubles

- If there is not any other wrong when trouble occurs, emergency operation starts as the indoor controller board switch (SWE) is set to ON.
During the emergency operation the indoor unit is as follows;
 - Indoor fan high speed operation
- When emergency operating for COOL or HEAT, setting of the switch (SWE) in the indoor controller board and outdoor unit emergency operation are necessary.
- Check items and notices as the emergency operation
 - Emergency operation cannot be used as follows;
 - When the outdoor unit is something wrong.
 - When the indoor fan is something wrong.
 - When drain over flow protected operation is detected during self-diagnosis. (Error code : P5)
 - Emergency operation will be serial operation by the power supply ON/OFF.
ON/OFF or temperature, etc. adjustment is not operated by the remote controller.
 - Do not operate for a long time as cold air is blown when the outdoor unit starts defrosting operation during heat emergency operation.
 - Cool emergency operation must be within 10 hours at most. It may cause heat exchanger frosting in the indoor unit.
 - After completing the emergency operation, return the switch setting, etc. in former state.
 - Since vane does not work at emergency operation, position the vane manually and slowly.

9-6. How to check the parts

PKA-RP1.6GAL

PKA-RP2GAL

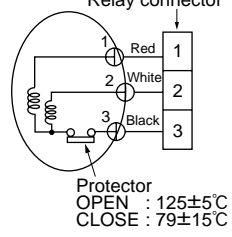
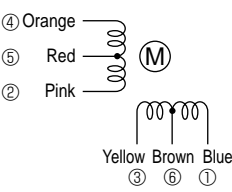
Parts name	Check points									
Room temperature thermistor (TH1) Pipe temperature thermistor/liquid (TH2) Condenser/evaporator temperature thermistor (TH5)	Disconnect the connector then measure the resistance using a tester. (Surrounding temperature 10°C ~30°C) <table border="1" style="margin-top: 10px;"> <thead> <tr> <th>Normal</th> <th>Abnormal</th> </tr> </thead> <tbody> <tr> <td>4.3kΩ~9.6kΩ</td> <td>Open or short</td> </tr> </tbody> </table>	Normal	Abnormal	4.3kΩ~9.6kΩ	Open or short					
Normal	Abnormal									
4.3kΩ~9.6kΩ	Open or short									
Fan motor (MF) 	Measure the resistance between the terminals using a tester. (Winding temperature 20°C) <table border="1" style="margin-top: 10px;"> <thead> <tr> <th rowspan="2">Motor terminal or Relay connector</th> <th>Normal</th> <th rowspan="2">Abnormal</th> </tr> <tr> <th>RP1.6, RP2</th> </tr> </thead> <tbody> <tr> <td>Red-Black</td> <td>120.5Ω</td> <td rowspan="2">Open or short</td> </tr> <tr> <td>White-Black</td> <td>111.3Ω</td> </tr> </tbody> </table>	Motor terminal or Relay connector	Normal	Abnormal	RP1.6, RP2	Red-Black	120.5Ω	Open or short	White-Black	111.3Ω
Motor terminal or Relay connector	Normal		Abnormal							
	RP1.6, RP2									
Red-Black	120.5Ω	Open or short								
White-Black	111.3Ω									
Vane motor (MV) 	Measure the resistance between the terminals using a tester. (Surrounding temperature 20°C ~30°C) <table border="1" style="margin-top: 10px;"> <thead> <tr> <th>Connector</th> <th>Normal</th> <th>Abnormal</th> </tr> </thead> <tbody> <tr> <td>Brown-Yellow</td> <td rowspan="4">186~214Ω</td> <td rowspan="4">Open or short</td> </tr> <tr> <td>Brown-Blue</td> </tr> <tr> <td>Red-Orange</td> </tr> <tr> <td>Red-Pink</td> </tr> </tbody> </table>	Connector	Normal	Abnormal	Brown-Yellow	186~214Ω	Open or short	Brown-Blue	Red-Orange	Red-Pink
Connector	Normal	Abnormal								
Brown-Yellow	186~214Ω	Open or short								
Brown-Blue										
Red-Orange										
Red-Pink										

<Thermistor Characteristic graph>

Thermistor for lower temperature

- Room temperature thermistor (TH1)
- Pipe temperature thermistor/liquid (TH2)
- Condenser/evaporator temperature thermistor (TH5)

Thermistor $R_0 = 15k\Omega \pm 3\%$

Fixed number of $B = 3480K \pm 2\%$

$$R_t = 15 \exp \left\{ 3480 \left(\frac{1}{273+t} - \frac{1}{273} \right) \right\}$$

0°C	15kΩ
10°C	9.6kΩ
20°C	6.3kΩ
25°C	5.4kΩ
30°C	4.3kΩ
40°C	3.0kΩ

< Thermistor for lower temperature >

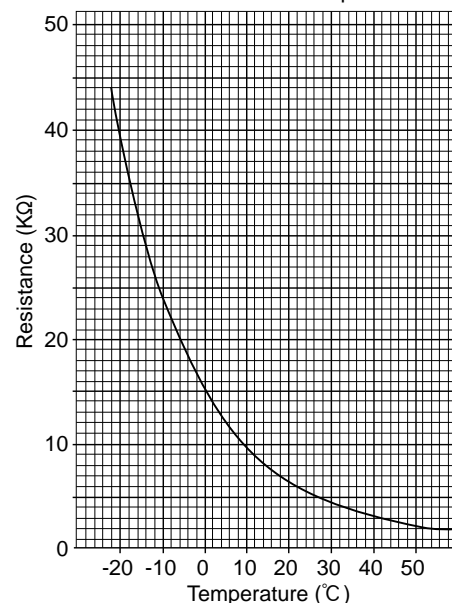

9-7. TEST POINT DIAGRAM

9-7-1. Indoor controller board

PKA-RP1.6GAL

PKA-RP2GAL

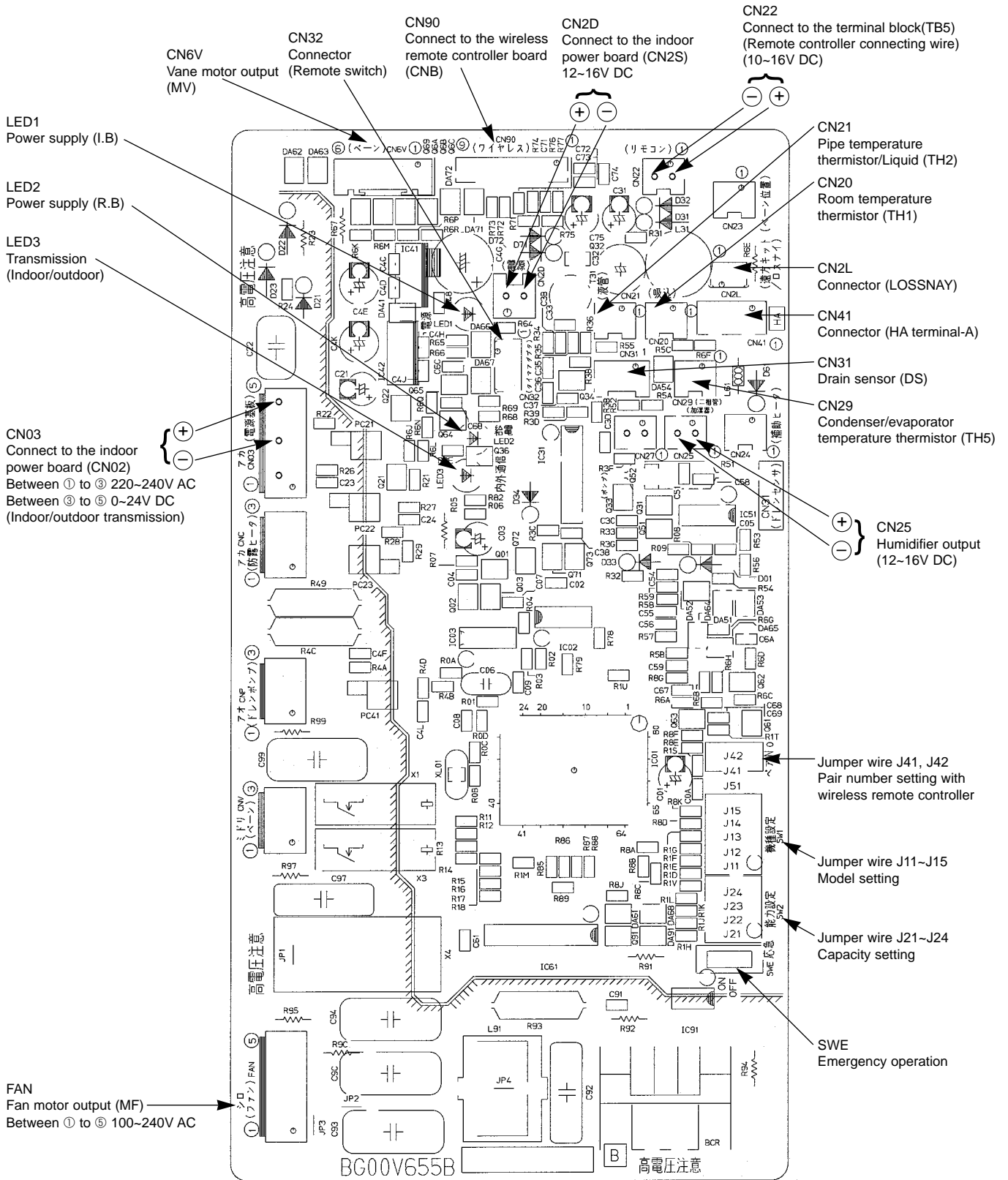

9-7-2. Indoor power board
PKA-RP1.6GAL
PKA-RP2GAL

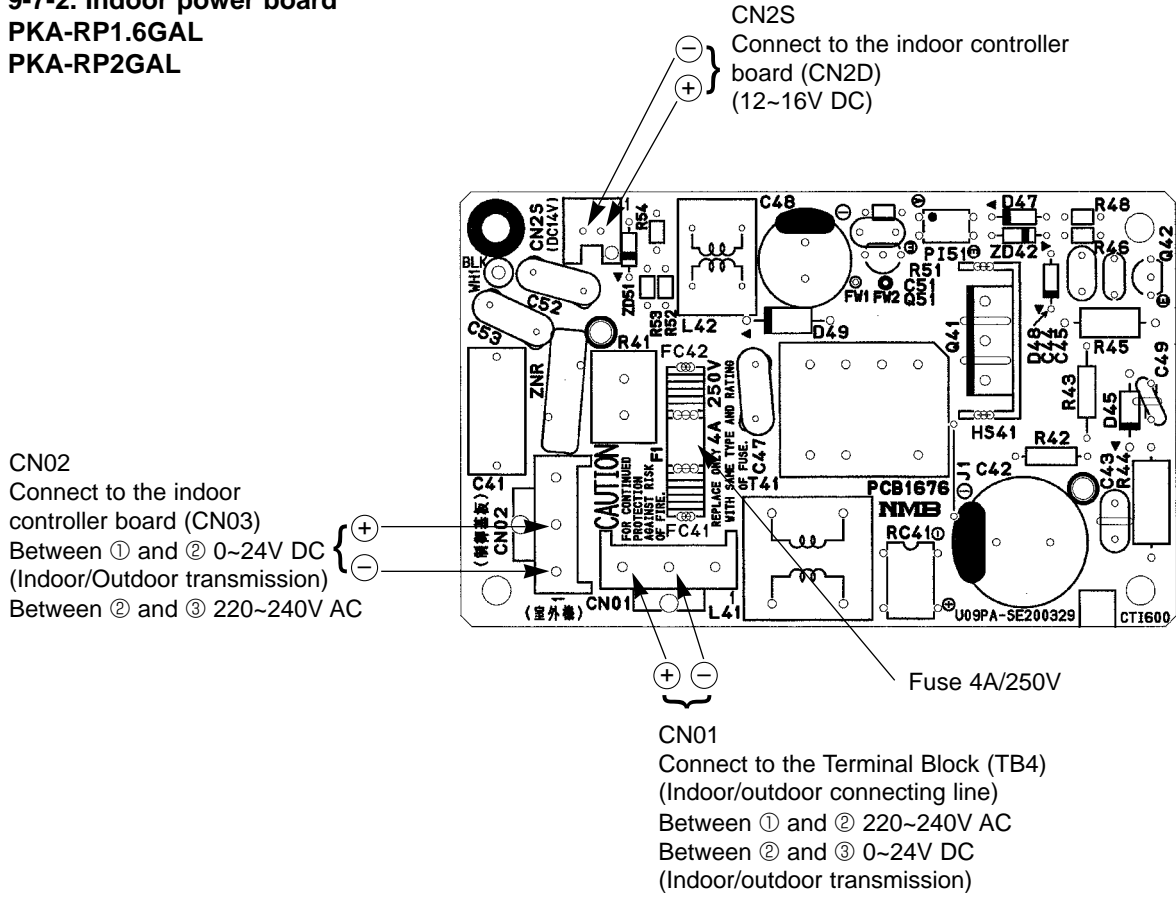

9-8. FUNCTIONS OF JUMPER WIRE

Each function is controlled by the jumper wire on control p.c. board. For service parts, J11- J15 and J21-J24, DIP switches (SW1 and SW2) are equipped with jumper wire.



(Marks in the table below) Jumper wire (○ : Short × : Open)
 DIP switch (○ : ON × : OFF)

Jumper wire	Functions	Open/short of jumper wire	Remarks																	
J11~J15 (SW1)	Model settings	Models : PKA-RP1.6, RP2 <table border="1"> <tr> <td></td> <td>J11</td> <td>J12</td> <td>J13</td> <td>J14</td> <td>J15</td> </tr> <tr> <td>Heater-less</td> <td>○</td> <td>○</td> <td>×</td> <td>○</td> <td>×</td> </tr> </table>		J11	J12	J13	J14	J15	Heater-less	○	○	×	○	×						
	J11	J12	J13	J14	J15															
Heater-less	○	○	×	○	×															
J21~J24 (SW2)	Capacity settings	<table border="1"> <tr> <td>Models</td> <td>J21</td> <td>J22</td> <td>J23</td> <td>J24</td> </tr> <tr> <td>RP1.6</td> <td>○</td> <td>○</td> <td>×</td> <td>×</td> </tr> <tr> <td>RP2</td> <td>○</td> <td>×</td> <td>○</td> <td>×</td> </tr> </table>	Models	J21	J22	J23	J24	RP1.6	○	○	×	×	RP2	○	×	○	×			
Models	J21	J22	J23	J24																
RP1.6	○	○	×	×																
RP2	○	×	○	×																
J41 J42	Pair number setting with wireless remote controller	<table border="1"> <tr> <td rowspan="2">Wireless remote controller setting</td> <td colspan="2">Control PCB setting</td> </tr> <tr> <td>J41</td> <td>J42</td> </tr> <tr> <td>0</td> <td>○</td> <td>○</td> </tr> <tr> <td>1</td> <td>×</td> <td>○</td> </tr> <tr> <td>2</td> <td>○</td> <td>×</td> </tr> <tr> <td>3 ~ 9</td> <td>×</td> <td>×</td> </tr> </table>	Wireless remote controller setting	Control PCB setting		J41	J42	0	○	○	1	×	○	2	○	×	3 ~ 9	×	×	<Settings at time of factory shipment> Wireless remote controller: 0 Control PCB: ○ (for both J41 and J42) Four pair number settings are supported. The pair number settings of the wireless remote controller and indoor control PCB (J41/J42) are given in the table on the left. ('×' in the table indicates the jumper line is disconnected.)
Wireless remote controller setting	Control PCB setting																			
	J41	J42																		
0	○	○																		
1	×	○																		
2	○	×																		
3 ~ 9	×	×																		

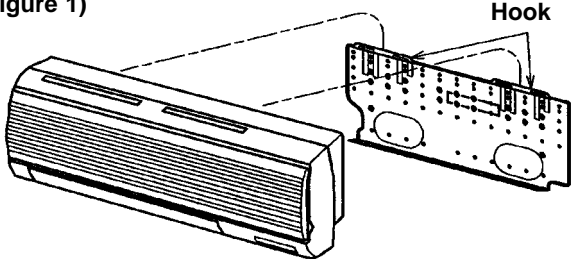
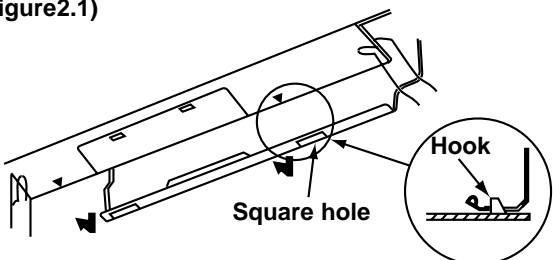
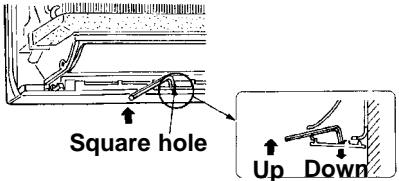
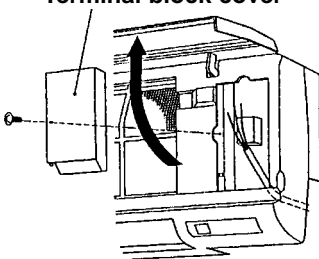
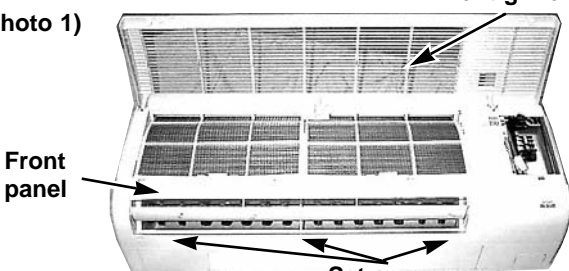
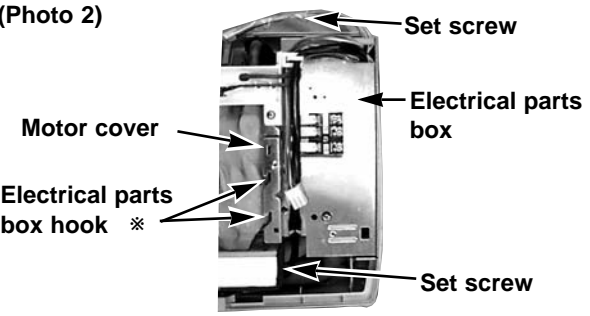
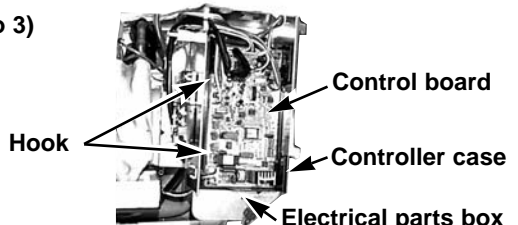
PKA-RP1.6GAL
PKA-RP2GAL

OPERATION PROCEDURE	PHOTOS & ILLUSTRATION
<p>1. REMOVE THE LOWER SIDE OF THE INDOOR UNIT FROM THE INSTALLATION PLATE.</p> <p>(1) Remove the left / right corner box of the indoor unit.</p> <p>(2) Hold and pull down the lower and both ends of the indoor unit, and remove the ▼ section from the square hole. (Refer to the figure 2.1) Or remove the front panel and push the ▼ section down by using hexagonal wrench ,etc. from the front side. (Refer to the figure 2.2).</p> <p>(3) Unhook the top of the indoor unit from the back plate catch.</p>	<p>(Figure 1)</p>  <p>(Figure2.1)</p> 
<p>(Figure 2.2)</p>  <p>2. REMOVING THE FRONT PANEL.</p> <p>(1) Open the front grille.</p> <p>(2) Remove the terminal block cover with a screw.</p> <p>(3) Remove the screw 3caps then remove the set 3screws.</p> <p>(4) After removing the lower side of the front panel a little, remove it as pulling toward upper.</p>	<p>(Figure 3)</p>  <p>(Photo 1)</p> 
<p>3. REMOVING THE INDOOR CONTROLLER BOARD.</p> <p>(1) Remove the terminal block cover.</p> <p>(2) Remove the front panel. (see the photo 1)</p> <p>(3) Remove the electrical parts box(2screws).</p> <p>(4) Remove the electrical parts box cover(1screw).</p> <p>(5) Disconnect the connector on the controller board and remove the controller board by Pulling up the hook of the controller case.</p> <p>※ To smooth works, hang the side hooks of the electrical parts box on the hook of the motor cover. (see the photo 3)</p>	<p>(Photo 2)</p>  <p>(Photo 3)</p> 

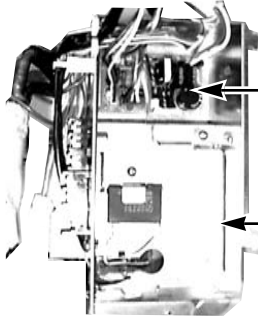

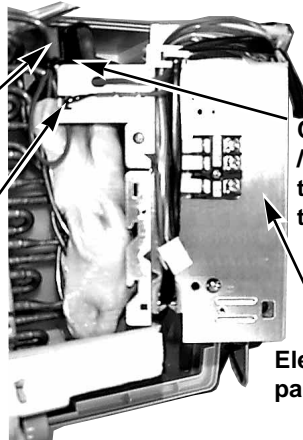
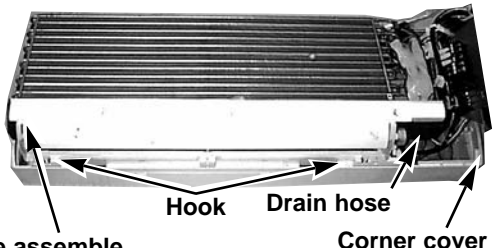
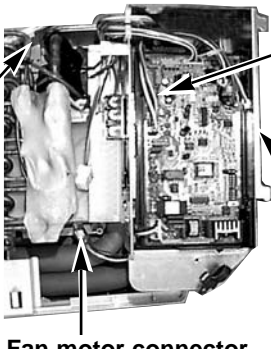
OPERATION PROCEDURE	PHOTOS & ILLUSTRATION
<p>4. REMOVING THE POWER BOARD</p> <ol style="list-style-type: none">(1) Remove the front panel.(see the photo 1)(2) Remove the electrical parts box(2screws).(see the photo 2)(3) Disconnect the whole connector in the control board.(4) After lifting the controller case with pressing it's convex section, remove the controller case and the control board simultaneously.(see the photo 3)(5) Disconnect the connector in the power board.(6) Remove the power board.	<p>(Photo 4)</p>  <p>Power board</p> <p>Electrical parts box</p>
<p>5. REMOVING THE VANE MOTOR</p> <ol style="list-style-type: none">(1) Disconnect the connector CN6V on the indoor controller board.(2) Remove the 2screws of the vane motor, disconnect the lead wire and remove the vane motor from the shaft.	<p>(Photo 5)</p>  <p>Nozzle assemble</p> <p>Set screws</p> <p>Van motor</p> <p>Lead wire</p>
<p>6. REMOVING THE THERMISTOR</p> <ol style="list-style-type: none">(1) Removing the room temperature thermistor TH1.<ol style="list-style-type: none">①Disconnect the connector CN20<red> on the indoor controller board.②Remove the room temperature thermistor from the holder.(2) Removing the pipe temperature thermistor TH2.<ol style="list-style-type: none">①Disconnect the connector CN21<white> on the controller board.②Remove the pipe temperature thermistor with set to the pipe.(3) Removing the indoor coil temperature thermistor TH5.<ol style="list-style-type: none">①Disconnect the connector CN29<black> on the indoor controller board.②Remove the gas pipe thermistor with set to the pipe.	<p>(Photo 6)</p>  <p>Pipe temperature thermistor</p> <p>Room temperature thermistor</p> <p>Condenser /evaporator temperature thermistor</p> <p>Electrical parts box</p>
<p>7. REMOVING THE NOZZLE ASSEMBLY</p> <ol style="list-style-type: none">(1) Disconnect the connector CN6V on the controller board.(2) Disconnect the lead wire of the vane motor.(3) Remove the corner cover.(4) Pull the drain hose out from the nozzle assemble.(5) Unhook the hook of the lower nozzle assemble and pull the nozzle assemble toward you,then remove the nozzle assemble by sliding it down.	<p>(Photo 7)</p>  <p>Nozzle assemble</p> <p>Hook</p> <p>Drain hose</p> <p>Corner cover</p>
<p>8. REMOVING THE ELECTRICAL PARTS BOX</p> <ol style="list-style-type: none">(1) Remove the terminal block cover.(2) Remove the front panel.(see the photo 1)(3) Disconnect the vane motor connector.(4) Disconnect the fan motor connector from the fan motor.(5) Remove the liquid / gas pipe thermistor.(see the photo 6)(6) Remove the electrical parts box (2screws).	<p>(Photo 8)</p>  <p>Pipe temperature thermistor</p> <p>Fan motor connector</p> <p>Vane motor connector</p> <p>Electrical parts box</p>



OPERATION PROCEDURE

PHOTOS & ILLUSTRATION

- 9. REMOVING THE FAN MOTOR.**
- (1) Remove the terminal block cover.
 - (2) Remove the front panel.(see the photo 1)
 - (3) Remove the electrical parts box.(see the photo 8)
 - (4) Remove the nozzle assemble.(see the photo 7)
 - (5) Remove the fan motor leg fixing 3screws.
 - (6) Unscrew the set screws using by alankey and remove it by sliding the fan motor to right.
 - (7) Remove the 4screws and remove the motor cover from the fan motor leg.

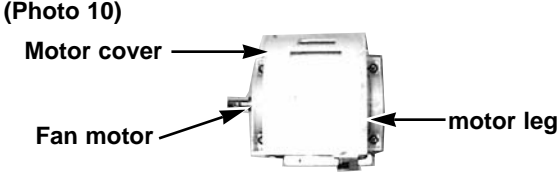
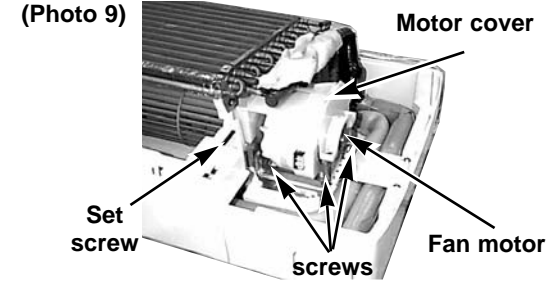

- 10. REMOVING THE LINE FLOW FAN**
- (1) Remove the terminal block cover.
 - (2) Remove the front panel.(see the photo 1)
 - (3) Remove the electrical parts box.(see the photo 8)
 - (4) Remove the nozzle assembly.(see the photo 7)
 - (5) Remove the fan motor.(see the photo 9)
 - (6) Remove the pipe fixture with 2screws.(see the photo12)
 - (7) Remove the left / right screws of the heat exchanger and pull the left-hand side up.
 - (8) Remove the 2screws by sliding it toward you remove the fixture(fixing bearing).
- ※ The fan motor is removable first , when the fan removing is hard.
- ※ When resetting the fan to the fan motor. Locate and fix the shaft after installing the fan.

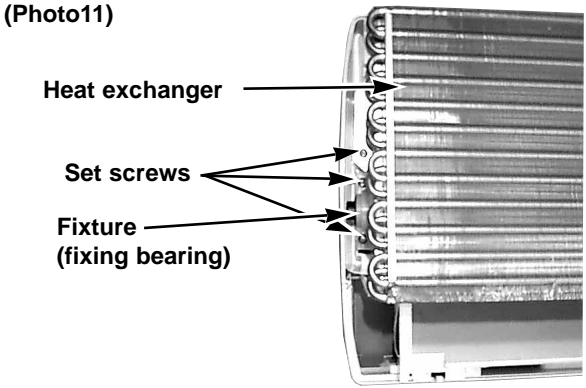

- 11. REMOVING THE HEAT EXCHANGER**
- (1) Remove the terminal block cover.
 - (2) Remove the front panel.(see the photo 1)
 - (3) Remove the electrical parts box.(see the photo 8)
 - (4) Remove the corner box.
 - (5) Remove the nozzle assemble.(see the photo 7)
 - (6) Remove the 2screws and the pipe fixture.
 - (7) Remove the 2screws and heat exchanger.

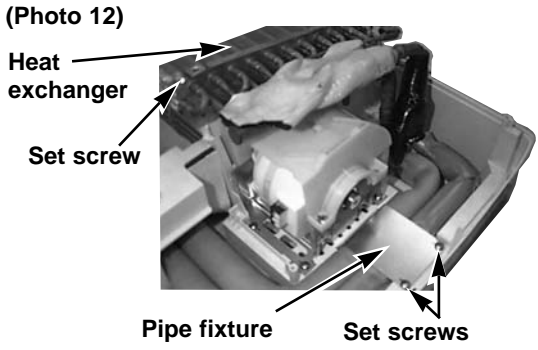

- 12. REMOVING the SIGNAL RECEIVING P.C. BOARD**
- (1) Remove the terminal block cover.
 - (2) Disconnect the connector <yellow> for the wireless remote controller.
 - (3) Remove the front panel.(see the photo 1)
 - (4) Remove the 2screws and signal receiving p.c. board cover.
 - (5) Remove the signal receiving p.c. board.

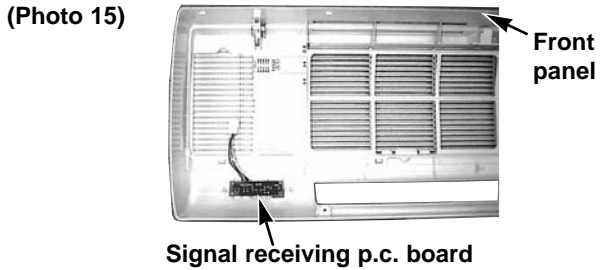
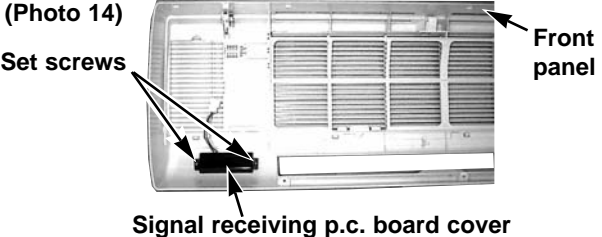

STRUCTURAL PARTS
PKA-RP1.6GAL
PKA-RP2GAL

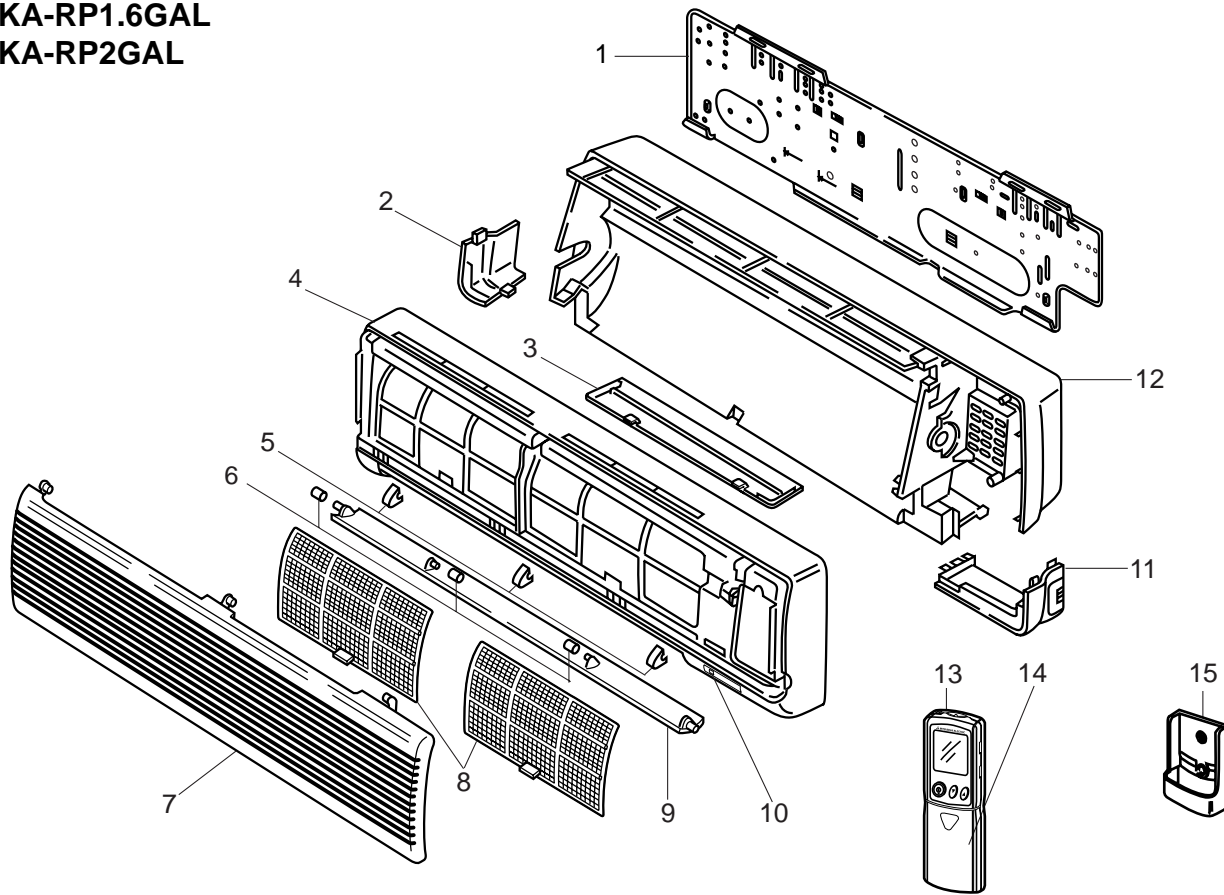

No.	Parts No.	Parts Name	Specifications	Q'ty/set	Remarks (Drawing No.)	Wiring Diagram Symbol	Recom- mended Q'ty	Price	
				PKA-RP1.6GAL PKA-RP2GAL				Unit	Amount
1	R01 07Y 808	BACK PLATE		1					
2	R01 09Y 658	CORNER COVER		1					
3	R01 07Y 623	UNDER COVER		1					
4	R01 89Y 651	FRONT PANEL		1					
5	R01 07Y 096	SCREW CAP		3					
6	R01 07Y 092	VANE SLEEVE		1					
7	R01 07Y 691	FRONT GRILLE		1					
8	R01 A16 500	AIR FILTER		2					
9	R01 07Y 002	AUTO VANE		1					
10	R01 24K 658	RECEIVING UNIT		1		RU			
11	R01 07Y 658	CORNER COVER		1					
12	R01 07Y 635	BOX ASSEMBLY		1					
13	T7W E06 714	WIRELESS REMOTE CONTROLLER		1					
14	R01 E01 049	WIRELESS REMOTE CONTROLLER DOOR		1					
15	R01 E00 075	WIRELESS REMOTE CONTROLLER HOLDER		1					

ELECTRICAL PARTS
PKA-RP1.6GAL
PKA-RP2GAL

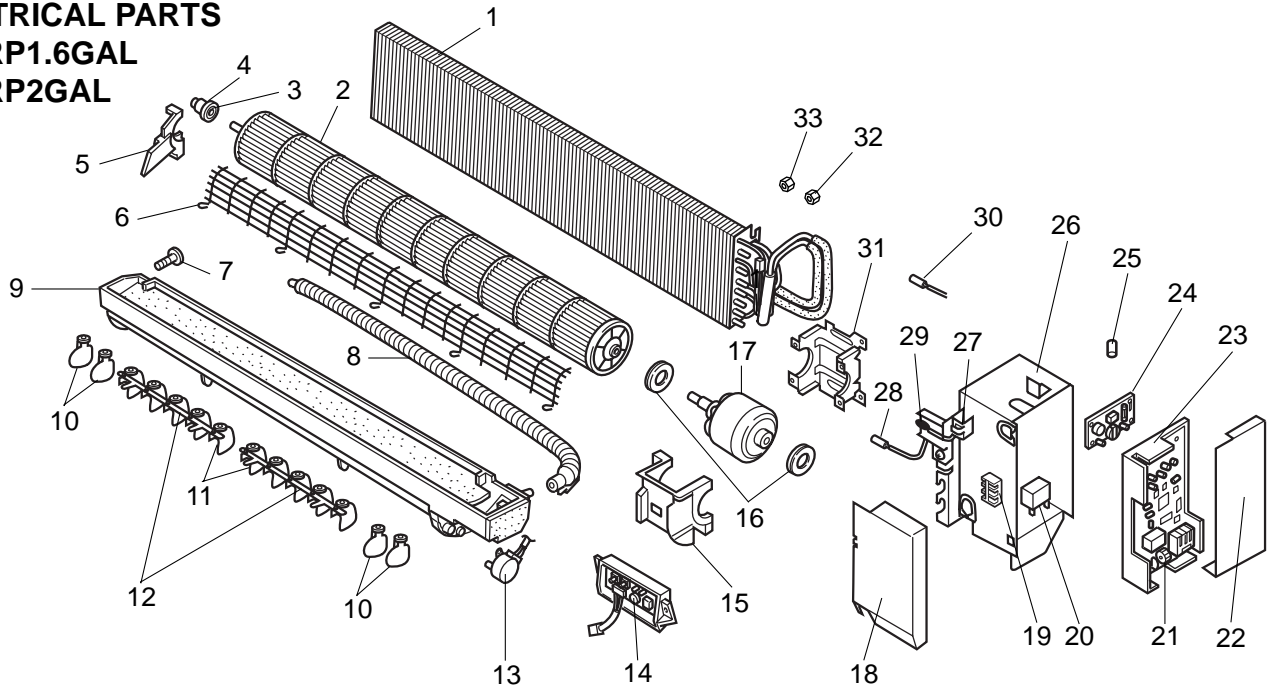

No.	Parts No.	Parts Name	Specifications	Q'ty/set	Remarks (Drawing No.)	Wiring Diagram Symbol	Recom- mended Q'ty	Price	
				PKA-PR1.6GAL PKA-RP2GAL				Unit	Amount
1	T7W E50 480	HEAT EXCHANGER		1					
2	R01 07Y 114	LINE FLOW FAN		1					
3	R01 07Y 102	BEARING MOUNT		1					
4	R01 005 103	SLEEVE BEARING		1					
5	R01 07Y 106	BEARING SUPPORT		1					
6	T7W A00 675	FAN GUARD		1					
7	R01 07Y 524	DRAIN PLUG		1					
8	R01 07Y 527	DRAIN HOSE		1					
9	T7W E13 530	NOZZLE		1					
10	R01 09Y 038	GUIDE VANE		4					
11	R01 07Y 038	GUIDE VANE		10					
12	R01 07Y 059	ARM		2					
13	R01 E02 223	VANE MOTOR		1		MV			
14	R01 50J 317	WIRERLESS ADAPTER CONTROLLER BOARD		1		W.B			
15	R01 07Y 135	MOTOR COVER		1					
16	R01 07Y 105	RUBBER MOUNT		2					
17	T7W A01 762	FAN MOTOR	PM4V30-K	1		MF			
18	—	TERMINAL COVER		1	(BG02V195H10)				
19	T7W E13 716	TERMINAL BLOCK	3P(S1, S2, S3)	1		TB4			
20	R01 588 255	CAPACITOR	2.0 μ F X440V	1		C			
21	T7W E36 310	INDOOR CONTROLLER BOARD		1		I.B			
22	—	CONTROLLER COVER		1	(BG02V194H05)				
23	—	CONTROLLER CASE		1	(BG25B573H06)				
24	T7W E01 313	POWER BOARD		1		P.B			
25	T7W E00 239	FUSE	250V 4A	1		F1			
26	—	ELECTRICAL PARTS COVER		1	(BG00V196G41)				
27	—	SENSOR HOLDER		1	(RG25C546H06)				
28	R01 E32 202	CONDENSER / EVAPORATOR TEMPERATURE THERMISTOR		1		TH5			
29	T7W E05 202	ROOM TEMPERATURE THERMISTOR		1		TH1			
30	T7W E06 202	PIPE TEMPERATUER THERMISTOR		1		TH2			
31	R01 07Y 130	MOTOR SUPPORT		1					
32	T7W E02 457	FLARE NUT	1/2	1					
33	T7W E01 457	FLARE NUT	1/4	1					

12-1. Wired Remote Controller (with terminal bed).

Part No.	PAR-20MAAT-E
----------	--------------

12-2. Program Timer

Part No.	PAC-SC32PTA
----------	-------------

12-3. Remote Sensor

Part No.	PAC-SE41TS-E
----------	--------------

12-4. Remote Operation Adapter

Part No.	PAC-SF40RM-E
----------	--------------

12-5. Remote ON/OFF Adapter

Part No.	PAC-SE55RA-E
----------	--------------



HEAD OFFICE : MITSUBISHI DENKI BLDG., 2-2-3, MARUNOUCHI, CHIYODA-KU, TOKYO100-8310, JAPAN