

Air-Conditioners

SLZ- KA25, KA35, KA50VAQ KA25, KA35, KA50VAL

INSTALLATION MANUAL

For safe and correct use, please read this manual and the outdoor unit installation manual thoroughly before installing the air-conditioner unit.

FOR INSTALLER

INSTALLATIONSHANDBUCH

Aus Sicherheitsgründen und zur richtigen Anwendung vor Installation der Klimaanlage die vorliegende Bedienungsanleitung und das Installationshandbuch gründlich durchlesen.

FÜR INSTALLATEURE

MANUEL D'INSTALLATION

Avant d'installer le climatiseur, lire attentivement ce manuel, ainsi que le manuel d'installation de l'appareil extérieur pour une utilisation sûre et correcte.

POUR L'INSTALLATEUR

INSTALLATIEHANDLEIDING

Lees deze handleiding en de installatiehandleiding van het buitenapparaat zorgvuldig door voordat u met het installeren van de airconditioner begint.

VOOR DE INSTALLATEUR

MANUAL DE INSTALACIÓN

Para un uso seguro y correcto, lea detalladamente este manual de instalación antes de montar la unidad de aire acondicionado.

PARA EL INSTALADOR

MANUALE DI INSTALLAZIONE

Per un uso sicuro e corretto, prima di installare il condizionatore d'aria leggere attentamente il presente manuale ed il manuale d'installazione dell'unità esterna.

PER L'INSTALLATORE

ΕΓΧΕΙΡΙΔΙΟ ΟΔΗΓΙΩΝ ΕΓΚΑΤΑΣΤΑΣΗΣ

Για σωστή και ασφαλή χρήση, διαβάστε προσεκτικά αυτό το εγχειρίδιο, καθώς και το εγχειρίδιο εγκατάστασης της εξωτερικής μονάδας, πριν από την εγκατάσταση της μονάδας κλιματιστικού.

ΓΙΑ ΑΥΤΟΝ ΠΟΥ ΚΑΝΕΙ ΤΗΝ ΕΓΚΑΤΑΣΤΑΣΗ

MANUAL DE INSTALAÇÃO

Para uma utilização segura e correcta, leia atentamente este manual e o manual de instalação da unidade exterior antes de instalar o aparelho de ar condicionado.

PARA O INSTALADOR

INSTALLATIONSMANUAL

Läs bruksanvisningen och utomhusenhetens installationshandbok noga innan luftkonditioneringen installeras så att den används på ett säkert och korrekt sätt.

FÖR INSTALLATÖREN

РУКОВОДСТВО ПО УСТАНОВКЕ

Для обеспечения безопасной и надлежащей эксплуатации внимательно прочтите данное руководство и руководство по установке наружного прибора перед установкой кондиционера.

ДЛЯ УСТАНОВИТЕЛЯ**English****Deutsch****Français****Nederlands****Español****Italiano****Ελληνικά****Português****Svenska****Русский**

Contents

1. Safety precautions	2	6. Drainage piping work	6
2. Selecting the installation location	2	7. Electrical work	7
3. Installation diagram	3	8. Installing the grille	10
4. Installing the indoor unit	3	9. Test run	12
5. Refrigerant piping work	5		

Note:
The phrase "Wired remote controller" in this installation manual refers only to the PAR-21MAA. If you need any information for the PAR-30MAA, please refer to either the installation manual or initial setting manual which are included in PAR-30MAA box.

1. Safety precautions

- Be sure to read "Safety precautions" before installing the air conditioner.
- Be sure to observe the cautions specified here as they include important items related to safety.
- The indications and meanings are as follows.

⚠ Warning:
Could lead to death, serious injury, etc.

⚠ Caution:
Could lead to serious injury in particular environments when operated incorrectly.

- **⚠ Warning:**
Do not install it by yourself (customer). Incomplete installation could cause injury due to fire, electric shock, the unit falling or leakage of water. Consult the dealer from whom you purchased the unit or special installer.
- Install the unit securely in a place which can bear the weight of the unit. When installed in an insufficient strong place, the unit could fall causing injured.
- Use the specified wires to connect the indoor and outdoor units securely and attach the wires firmly to the terminal board connecting sections so the stress of the wires is not applied to the sections. Incomplete connecting and fixing could cause fire.
- Do not use intermediate connection of the power cord or the extension cord and do not connect many devices to one AC outlet. It could cause a fire or an electric shock due to defective contact, defective insulation, exceeding the permissible current, etc.
- Check that the refrigerant gas does not leak after installation has completed.

- **⚠ Caution:**
Perform grounding. Do not connect the ground wire to a gas pipe, water pipe arrester or telephone ground wire. Defective grounding could cause an electric shock.
- Do not install the unit in a place where an inflammable gas leaks. If gas leaks and accumulates in the area surrounding the unit, it could cause an explosion.
- Install a ground leakage breaker depending on the installation place (where it is humid). If a ground leakage breaker is not installed, it could cause an electric shock.

- After reading this manual, be sure to keep it together with the instruction manual in a handy place on the customer's site.

⚡ : Indicates a part which must be grounded.

⚠ Warning:
Carefully read the labels affixed to the main unit.

- Perform the installation securely referring to the installation manual. Incomplete installation could cause a personal injury due to fire, electric shock, the unit falling or leakage of water.
- Perform electrical work according to the installation manual and be sure to use an exclusive circuit. If the capacity of the power circuit is insufficient or there is incomplete electrical work, it could result in a fire or an electric shock.
- Attach the electrical part cover to the indoor unit and the service panel to the outdoor unit securely. If the electrical part cover in the indoor unit and/or the service panel in the outdoor unit are not attached securely, it could result in a fire or an electric shock due to dust, water, etc.
- Be sure to use the part provided or specified parts for the installation work. The use of defective parts could cause an injury or leakage of water due to a fire, an electric shock, the unit falling, etc.
- Ventilate the room if refrigerant leaks during operation. If the refrigerant comes in contact with a flame, poisonous gases will be released.

- Perform the drainage/piping work securely according to the installation manual. If there is a defect in the drainage/piping work, water could drop from the unit and household goods could be wet and damaged.
- Fasten a flare nut with a torque wrench as specified in this manual. When fastened too tight, a flare nut may be broken after a long period and cause a leakage of refrigerant.

2. Selecting the installation location

2.1. Indoor unit

- Where airflow is not blocked.
- Where cool air spreads over the entire room.
- Where it is not exposed to direct sunshine.
- At a distance 1 m or more away from your TV and radio (to prevent picture from being distorted or noise from being generated).
- In a place as far away as possible from fluorescent and incandescent lights (so the infrared remote control can operate the air conditioner normally).

- Where the air filter can be removed and replaced easily.

⚠ Warning:
Mount the indoor unit into a ceiling strong enough to withstand the weight of the unit.

2.2. Wireless remote controller mounting (For SLZ-KA25/KA35/KA50VAL)

- Place of mounting
 - Where it is easy to operate and easily visible.
 - Where children can not touch.
- Mounting
Select a position about 1.2 m above the floor, check that signals from the remote controller are surely received by the indoor unit from that position ('beep' or 'beep-beep' receiving tone sounds). After that, attach remote controller holder to a pillar or wall and set the wireless remote controller.

In rooms where inverter type fluorescent lamps are used, the signal from the wireless remote controller may not be received.

3. Installation diagram

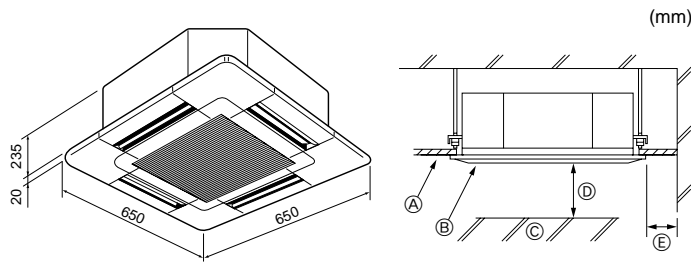

Fig. 3-1

3.1. Indoor unit (Fig. 3-1)

- Ⓐ Ceiling
 - Ⓑ Grille
 - Ⓒ Obstacle
 - Ⓓ Min. 1000 mm
 - Ⓔ Min. 500 mm (Entire periphery)
- If setting the maintenance space for Ⓔ, be sure to leave is a minimum of 700 mm.

Warning:
Mount the indoor unit on a ceiling strong enough to withstand the weight of the unit.

3.2. Outdoor unit

Refer to the outdoor unit installation manual.

4. Installing the indoor unit

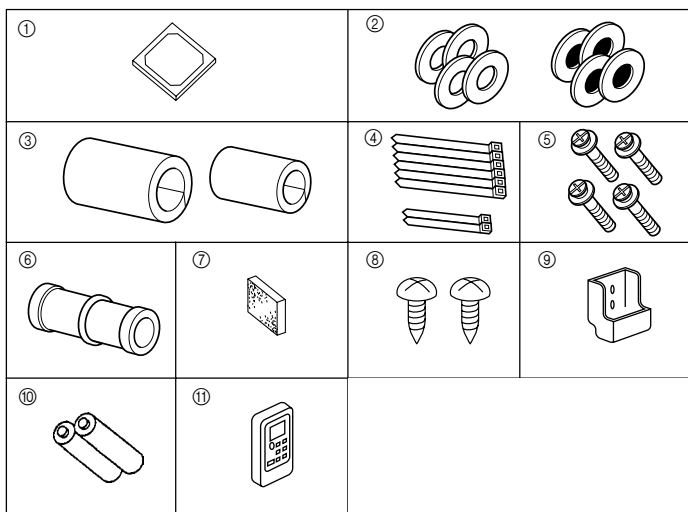

Fig. 4-1

4.1. Check the indoor unit accessories (Fig. 4-1)

The indoor unit should be supplied with the following accessories.

	Accessory name	Q'ty
①	Installation template	1
②	Washers (with insulation)	4
	Washers (without insulation)	4
③	Pipe cover (for refrigerant piping joint)	
	small diameter (liquid)	1
	large diameter (gas)	1
④	Band (large)	6
	Band (small)	2
⑤	Screw with washer (M5 × 25) for mounting grille	4
⑥	Drain socket	1
⑦	Insulation	1
⑧	Fixing screw for ⑨ 3.5 × 16 (Black) (for SLZ-KA-VAL)	2
⑨	Remote controller holder (for SLZ-KA-VAL)	1
⑩	Battery (AAA) (for SLZ-KA-VAL)	2
⑪	Wireless remote controller (for SLZ-KA-VAL)	1

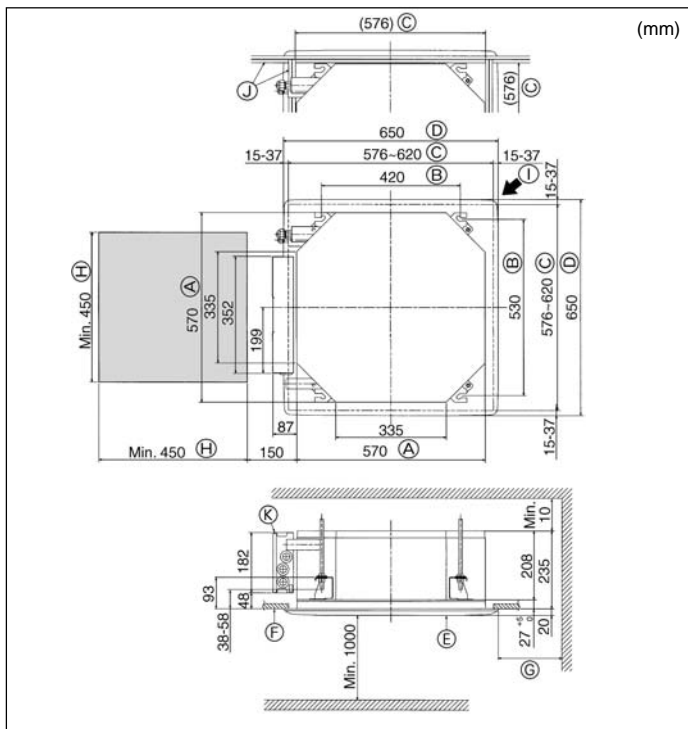

Fig. 4-2

4.2. Ceiling openings and suspension bolt installation locations (Fig. 4-2)

- Using the installation template (top of the package) and the gauge (supplied as an accessory with the grille), make an opening in the ceiling so that the main unit can be installed as shown in the diagram. (The method for using the template and the gauge are shown.)
 - * Before using, check the dimensions of template and gauge, because they change due to fluctuations of temperature and humidity.
 - * The dimensions of ceiling opening can be regulated within the range shown in following diagram; so center the main unit against the opening of ceiling, ensuring that the respective opposite sides on all sides of the clearance between them becomes identical.
 - Use M10 (3/8") suspension bolts.
 - * Suspension bolts are to be procured at the field.
 - Install securely, ensuring that there is no clearance between the ceiling panel & grille, and between the main unit & grille.
 - Ⓐ Outer side of main unit
 - Ⓑ Bolt pitch
 - Ⓒ Ceiling opening
 - Ⓓ Outer side of Grille
 - Ⓔ Grille
 - Ⓕ Ceiling
 - Ⓖ Min. 500 mm (Entire periphery)
 - Ⓗ Maintenance space
 - Ⓘ Fresh air intake
 - Ⓚ Angle
 - Ⓛ Electric component box
- * Note that the space between ceiling panel of the unit and ceiling slab, etc., must be 10 to 15 mm to be left.
- * Leave the maintenance space at the electric component box end.

4. Installing the indoor unit

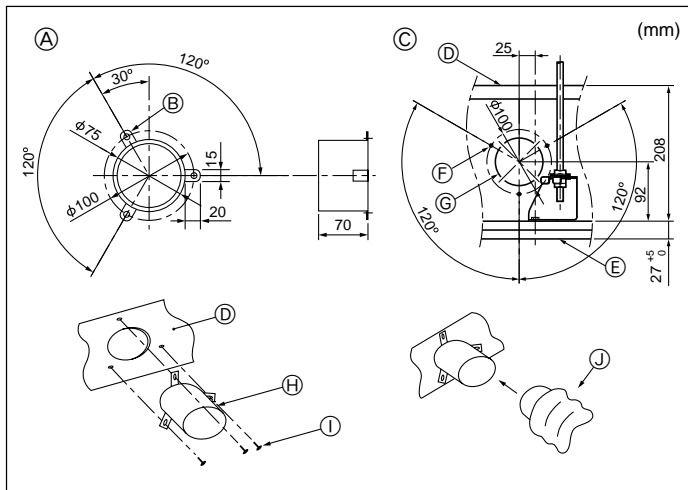

Fig. 4-3

4.3. Installation of duct (in case of fresh air intake) (Fig. 4-3)

⚠ Caution:

Linkage of duct fan and air conditioner

In case that a duct fan is used, be sure to make it linked with the air conditioner when outside air is taken.

Do not run the duct fan only. It can cause dew drop.

Making a duct flange (prepared locally)

- The shape of duct flange shown left is recommended.

Installation of duct flange

- Cut out the cutout hole. Do not knock it out.
- Install a duct flange to the cutout hole of the indoor unit with three 4 × 10 tapping screws which should be prepared locally.

Installation of duct (should be prepared locally)

- Prepare a duct of which inner diameter fits into the outer diameter of the duct flange.
- In case that the environment above the ceiling is high temperature and high humidity, wrap the duct in a heat insulate to avoid causing dew drop on the wall.

- | | |
|--|---|
| (A) Duct flange recommended shape
(Thickness:0.8 or more) | (F) 3-ø2.8 Burring hole |
| (B) 3-ø5 hole | (G) ø73.4 cutout hole |
| (C) Detail drawing of fresh air intake | (H) Duct flange (Prepared locally) |
| (D) Indoor unit | (I) 4 × 10 Tapping screw (Prepared locally) |
| (E) Ceiling surface | (J) Duct |

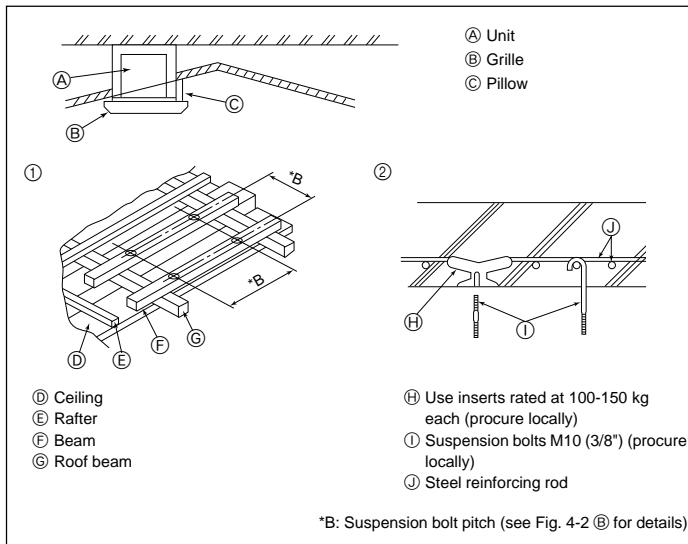

Fig. 4-4

4.4. Suspension structure (Give site of suspension strong structure) (Fig. 4-4)

- The ceiling work differs according to the construction of the building. Building constructors and interior decorators should be consulted for details.

- Extent of ceiling removal: The ceiling must be kept completely horizontal and the ceiling foundation (framework: wooden slats and slat holders) must be reinforced in order to protect the ceiling from vibration.
- Cut and remove the ceiling foundation.
- Reinforce the ends of the ceiling foundation where it has been cut and add ceiling foundation for securing the ends of the ceiling board.
- When installing the unit on a slanting ceiling, interlock a pillow between the ceiling and the grille and set so that the unit is installed horizontally.

① Wooden structures

- Use tie beams (single-story houses) or second floor beams (two story houses) as reinforcing members.
- Wooden beams for suspending air conditioners must be sturdy and their sides must be at least 6 cm long if the beams are separated by not more than 90 cm and their sides must be at least 9 cm long if the beams are separated by as much as 180 cm. The size of the suspension bolts should be ø10 (3/8"). (The bolts do not come with the unit.)

② Ferroconcrete structures

Secure the suspension bolts using the method shown, or use steel or wooden hangers, etc. to install the suspension bolts.

4.5. Unit suspension procedures (Fig. 4-5)

Suspend the main unit as shown in the diagram.

- In advance, set the parts onto the suspension bolts in the order of the washers (with insulation), washers (without insulation) and nuts (double).
 - Fit the washer with cushion so that the insulation faces downward.
 - In case of using upper washers to suspend the main unit, the lower washers (with insulation) and nuts (double) are to be set later.
- Lift the unit to the proper height of the suspension bolts to insert the mounting plate between washers and then fasten it securely.
- When the main unit can not be aligned against the mounting hole on the ceiling, it is adjustable owing to a slot provided on the mounting plate. (Fig. 4-6)
 - Make sure that step A is performed within 27-32 mm. Damage could result by failing to adhere to this range.

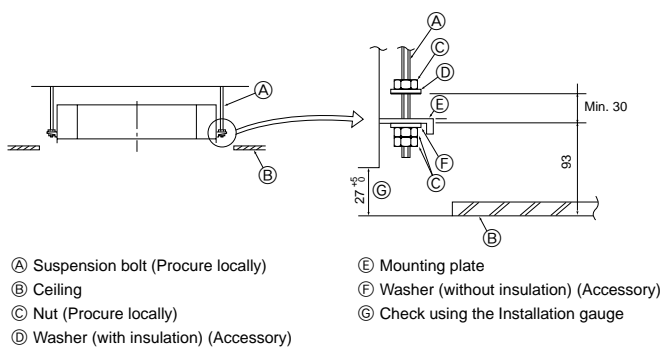

Fig. 4-5

4.6. Confirming the position of main unit and tightening the suspension bolts (Fig. 4-7)

- Using the gauge attached to the grille, ensure that the bottom of the main unit is properly aligned with the opening of the ceiling. Be sure to confirm this, otherwise condensation may form and drip due to air leakage etc.
- Confirm that the main unit is horizontally levelled, using a level or a vinyl tube filled with water.
- After checking the position of the main unit, tighten the nuts of the suspension bolts securely to fasten the main unit.
- The installation template can be used as a protective sheet to prevent dust from entering the main unit when the grilles are left unattached for a while or when the ceiling materials are to be lined after installation of the unit is finished.

* As for the details of fitting, refer to the instructions given on the Installation template.

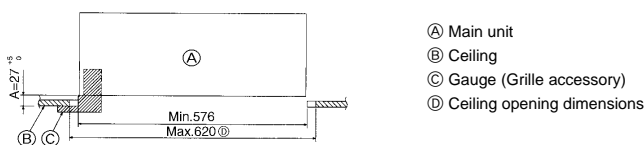

Fig. 4-6

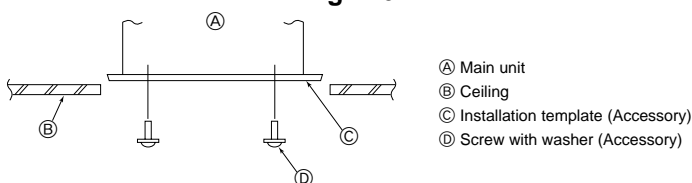

Fig. 4-7

5. Refrigerant piping work

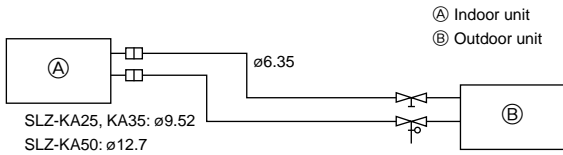

Fig. 5-1

5.1. Refrigerant pipe (Fig. 5-1)

Piping preparation

- Refrigerant pipes of 3, 5, 7, 10 and 15 m are available as optional items.

(1) Table below shows the specifications of pipes commercially available.

Model	Pipe	Outside diameter		Min. wall thickness	Insulation thickness	Insulation material
		mm	inch			
SLZ-KA25	For liquid	6.35	1/4	0.8 mm	8 mm	Heat resisting foam plastic 0.045 specific gravity
	For gas	9.52	3/8	0.8 mm	8 mm	
SLZ-KA35	For liquid	6.35	1/4	0.8 mm	8 mm	
	For gas	9.52	3/8	0.8 mm	8 mm	
SLZ-KA50	For liquid	6.35	1/4	0.8 mm	8 mm	
	For gas	12.7	1/2	0.8 mm	8 mm	

(2) Ensure that the 2 refrigerant pipes are well insulated to prevent condensation.

(3) Refrigerant pipe bending radius must be 100 mm or more.

⚠ Caution:

Using careful insulation of specified thickness. Excessive thickness prevents storage behind the indoor unit and smaller thickness causes dew drippage.

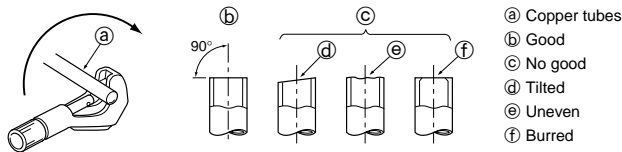

Fig. 5-2

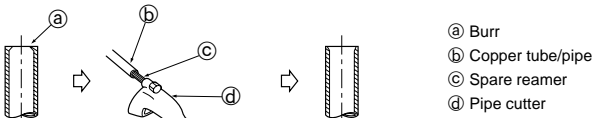

Fig. 5-3



Fig. 5-4

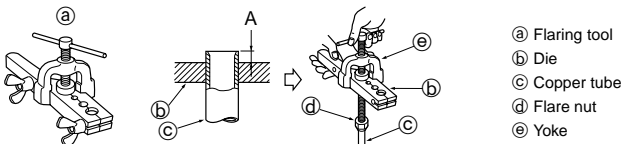

Fig. 5-5

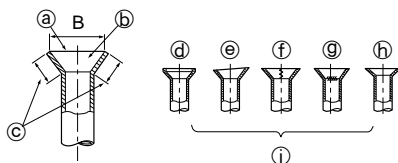

Fig. 5-6

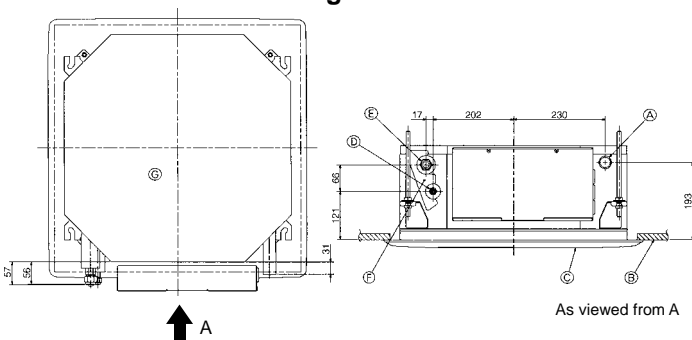

Fig. 5-7

5.2. Flaring work

- Main cause of gas leakage is defect in flaring work. Carry out correct flaring work in the following procedure.

5.2.1. Pipe cutting (Fig. 5-2)

- Using a pipe cutter cut the copper tube correctly.

5.2.2. Burrs removal (Fig. 5-3)

- Completely remove all burrs from the cut cross section of pipe/tube.
- Put the end of the copper tube/pipe to downward direction as you remove burrs in order to avoid burrs drop in the tubing.

5.2.3. Putting nut on (Fig. 5-4)

- Remove flare nuts attached to indoor and outdoor unit, then put them on pipe/tube having completed burr removal. (not possible to put them on after flaring work)

5.2.4. Flaring work (Fig. 5-5)

- Carry out flaring work using flaring tool as shown at the right.

Pipe diameter (mm)	Dimension	
	A (mm)	
	When the tool for R410A is used	B ± 0.4 (mm)
6.35	0 - 0.5	9.1
9.52	0 - 0.5	13.2
12.7	0 - 0.5	16.6

Firmly hold copper tube in a die in the dimension shown in the table at above.

5.2.5. Check (Fig. 5-6)

- Compare the flared work with a figure in right side hand.
- If flare is noted to be defective, cut off the flared section and do flaring work again.

- (a) Smooth all around
- (b) Inside is shining without any scratches
- (c) Even length all around
- (d) Too much
- (e) Tilted
- (f) Scratch on flared plane
- (g) Cracked
- (h) Uneven
- (i) Bad examples

5.3. Refrigerant and drainage piping locations (Fig.5-7)

- (A) Drain pipe
- (B) Ceiling
- (C) Grille
- (D) Refrigerant pipe (liquid)
- (E) Refrigerant pipe (gas)
- (F) Water supply inlet
- (G) Main unit

5. Refrigerant piping work

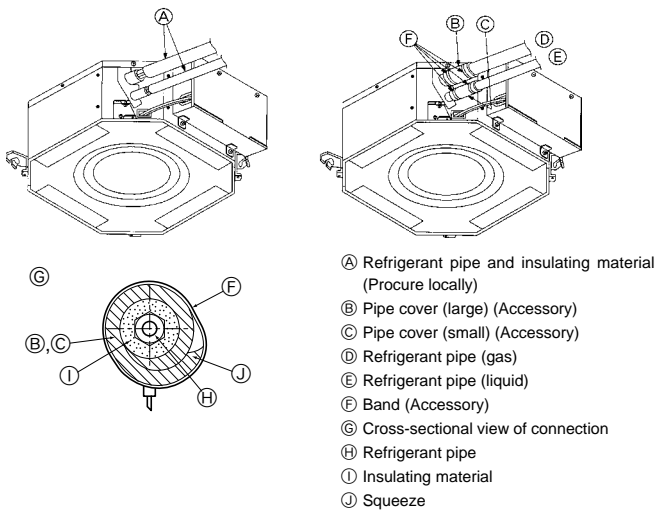

Fig. 5-8

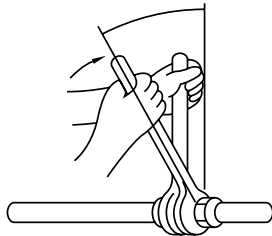

Fig. 5-9

5.4. Pipe connection (Fig. 5-8)

Indoor unit

1) When using commercially available copper pipes:

- Apply thin layer of refrigerant oil to pipe and joint seating surface before tightening flare nut.
- Use two wrenches to tighten piping connections.
- Air-purge the refrigerant piping using your own refrigerant gas (don't air-purge the refrigerant charged in the outdoor unit).
- Use leak detector or soapy water to check for gas leaks after connections are completed.
- Use refrigerant piping insulation provided to insulate indoor unit connections. Insulate carefully following shown below.

2) Heat insulation for refrigerant pipes:

- ① Wrap the enclosed large-sized pipe cover around the gas pipe, making sure that the end of the pipe cover touches the side of the unit.
- ② Wrap the enclosed small-sized pipe cover around the liquid pipe, making sure that the end of the pipe cover touches the side of the unit.
- ③ Secure both ends of each pipe cover with the enclosed bands. (Attach the bands 20 mm from the ends of the pipe cover.)

See that stop valve on outdoor unit is fully shut (unit is shipped with valve shut). After all piping connections between indoor and outdoor unit have been completed, vacuum-purge air from system through the service port for the stop valve on the outdoor unit. After completing procedures above, open outdoor unit stop valves stem fully. This completes connection of refrigerant circuit between indoor and outdoor units. Stop valve instructions are marked on outdoor unit.

- Apply a thin coat of refrigeration oil on the seat surface of pipe. (Fig. 5-9)
- For connection first align the center, then tighten the first 3 to 4 turns of flare nut.
- Use tightening torque table below as a guideline for indoor unit side union joint section, and tighten using two wrenches. Excessive tightening damages the flare section.

Copper pipe O.D. (mm)	Flare nut O.D. (mm)	Tightening torque (N·m)
ø6.35	17	14 - 18
ø9.52	22	34 - 42
ø12.7	26	49 - 61

⚠ Warning:

Be careful of flying flare nut! (Internally pressurized)

Remove the flare nut as follows:

1. Loosen the nut until you hear a hissing noise.
2. Do not remove the nut until the gas has been completely released (i.e., hissing noise stops).
3. Check that the gas has been completely released, and then remove the nut.

6. Drainage piping work

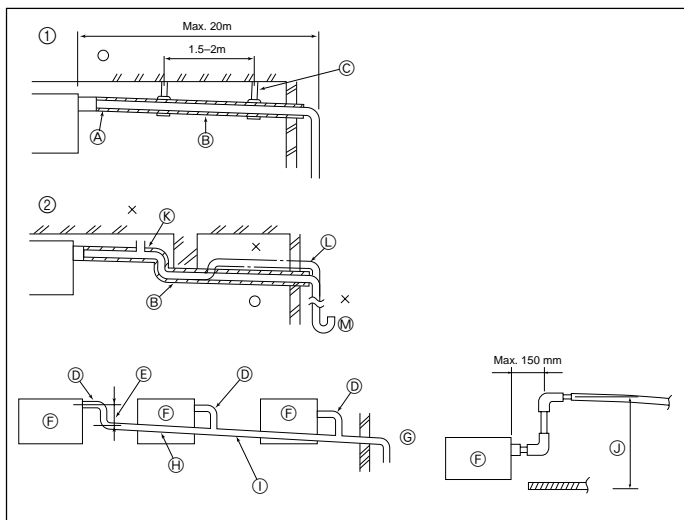

Fig. 6-1

6.1. Drainage piping work (Fig. 6-1)

- Use VP25 (O. D. ø32 PVC TUBE) for drain piping and provide 1/100 or more downward slope.
- Be sure to connect the piping joints using a polyvinyl type adhesive.
- Observe the figure for piping work.
- Use the included drain hose to change the extraction direction.

- ① Correct piping
- ② Wrong piping
- A Insulation (9 mm or more)
- B Downward slope (1/100 or more)
- C Support metal
- K Air bleeder
- L Raised
- M Odor trap

Grouped piping

- ① O. D. ø32 PVC TUBE
- ② Make it as large as possible
- F Indoor unit
- G Make the piping size large for grouped piping.
- H Downward slope (1/100 or more)
- I O. D. ø38 PVC TUBE for grouped piping. (9 mm or more insulation)
- J Up to 500 mm

6. Drainage piping work

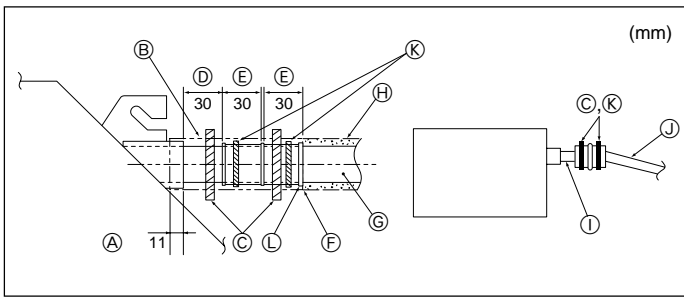

Fig. 6-2

1. Connect the drain socket (supplied with the unit) to the drain port. (Fig. 6-2) (Affix the tube using PVC adhesive then secure it with a band.)
2. Install a locally purchased drain pipe (PVC pipe, O.D. ø32). (Affix the pipe using PVC adhesive then secure it with a band.)
3. Insulate the tube and pipe. (PVC pipe, O.D. ø32 and socket)
4. Check that drain flows smoothly.
5. Insulate the drain port with insulating material, then secure the material with a band. (Both insulating material and band are supplied with the unit.)

- Ⓐ Main unit
- Ⓑ Insulating material
- Ⓒ Band (large)
- Ⓓ Drain port (transparent)
- Ⓔ Insertion margin
- Ⓕ Matching
- Ⓖ Drain pipe (O.D. ø32 PVC TUBE)
- Ⓗ Insulating material (purchased locally)
- Ⓘ Transparent PVC pipe
- Ⓝ O.D. ø32 PVC TUBE (Slope 1/100 or more)
- Ⓚ Band (small)
- Ⓛ Drain socket

7. Electrical work

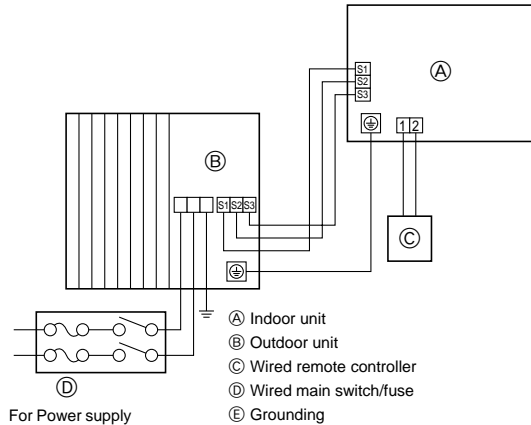

Fig. 7-1

7.1. Precautions (Fig. 7-1)

Electrical specification	Input capacity Main Switch/Fuse (A)		
	SLZ-KA25	SLZ-KA35	SLZ-KA50
Power supply (1 phase ~/N, 230V, 50Hz)	10	10	20

- The compressor will not operate unless the power supply phase connection is correct.
- Grounding protection with a no-fuse breaker (earth leakage breaker [ELB]) is usually installed for Ⓓ.
- The connection wiring between the outdoor and indoor units can be extended up to a maximum of 50 meters, and the total extension including the crossover wiring between rooms is a maximum of 80 m.

A switch with at least 3.5 mm contact separation in each pole shall be provided by the air conditioner installation.

* Label each breaker according to purpose (heater, unit etc.).

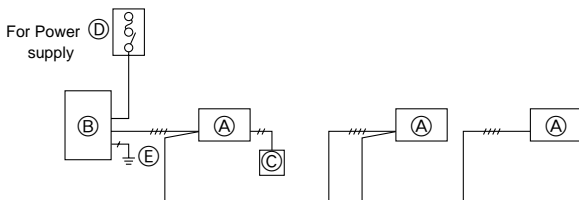

Fig. 7-2

7.2. Indoor unit (Fig. 7-2) (Fig. 7-3)

Work procedure

1. Remove 2 screws to detach the electric component cover.
 2. Route each cable through the wiring intake into the electric component box. (Procure power supply cable and indoor/outdoor connecting cable locally.)
 3. Securely connect the power supply cable and the indoor/outdoor connecting cable to the terminal blocks.
 4. Secure the cables with clamps outside the electric component box.
 5. Attach the electric component cover as it was.
- Fix power supply cable and indoor/outdoor connecting cable to electric component box by using buffer bushing for tensile force. (PG connection or the like.)

⚠ Warning:

- **Attach the electric component cover securely. If it is attached incorrectly, it could result in a fire, electric shock due to dust, water, etc.**
- **Use the specified indoor/outdoor unit connecting cable to connect the indoor and outdoor units and fix the cable to the terminal block securely so that no stress is applied to the connecting section of the terminal block. Incomplete connection or fixing of the cable could result in a fire.**

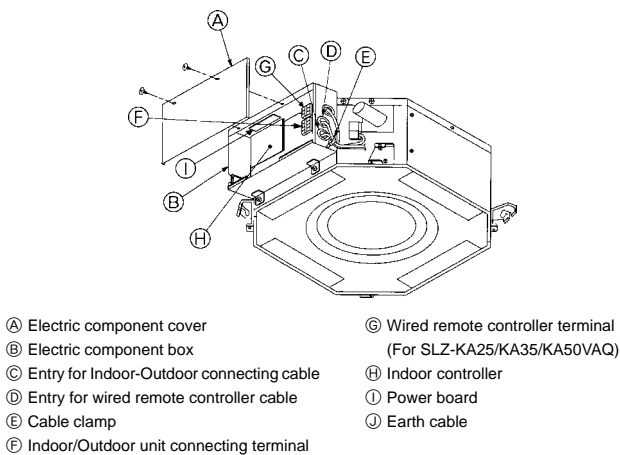
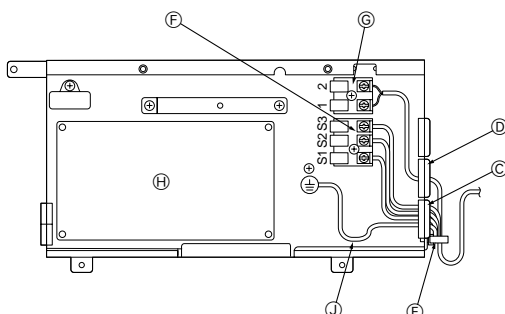

Fig. 7-3



7. Electrical work

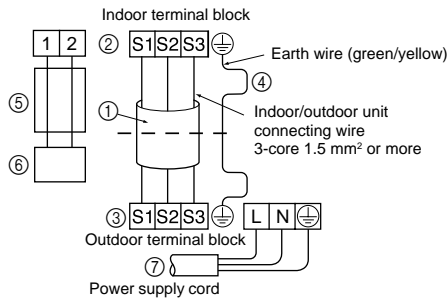

Fig. 7-4

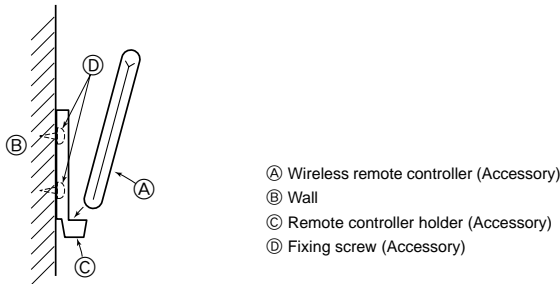

Fig. 7-5

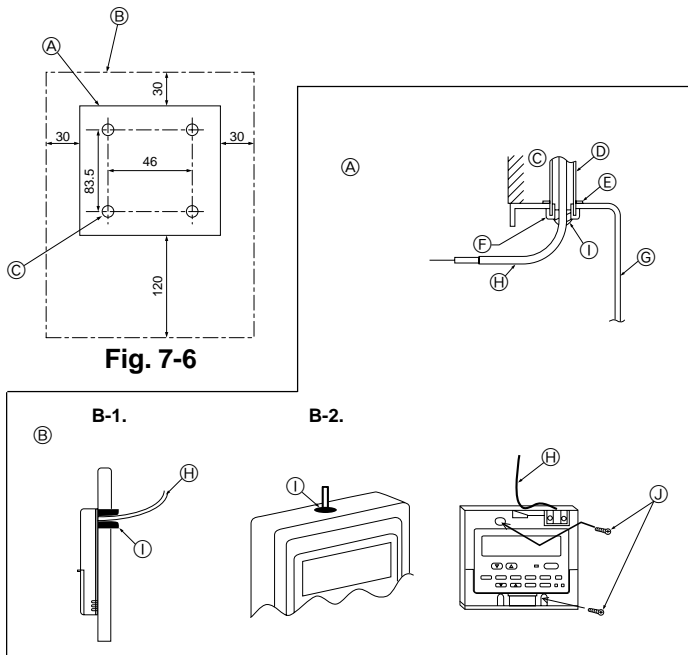

Fig. 7-7

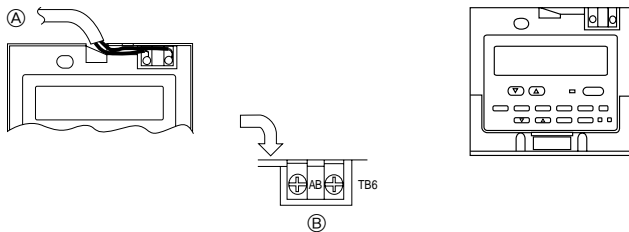

Fig. 7-8

- Perform wiring as shown in the diagram to the lower left. (Procure the cable locally). (Fig. 7-4)

Make sure to use cables of the correct polarity only.

- ① Connecting cable
Cable 3-core 1.5 mm², in conformity with Design 245 IEC 57.
- ② Indoor terminal block
- ③ Outdoor terminal block
- ④ Always install an earth wire (1-core 1.5 mm²) longer than other cables
- ⑤ Remote controller cable (non-polar)
Cable 2-core 0.3 mm²
The 10 m wire is attached in the remote controller accessory. Max. 500 m
- ⑥ Wired remote controller
- ⑦ Power supply cord

⚠ Caution:

- Use care not to make miswiring.
- Firmly tighten the terminal screws to prevent them from loosening.
- After tightening, pull the wires lightly to confirm that they do not move.

7.3. Remote controller

7.3.1. Wireless remote controller (Fig. 7-5)

1) Installation area

- Area in which the remote controller is not exposed to direct sunshine.
- Area in which there is no nearby heating source.
- Area in which the remote controller is not exposed to cold (or hot) winds.
- Area in which the remote controller can be operated easily.
- Area in which the remote controller is beyond the reach of children.

2) Installation method

- ① Attach the remote controller holder to the desired location using two tapping screws.
- ② Place the lower end of the controller into the holder.
- The signal can travel up to approximately 7 meters (in a straight line) within 45 degrees to both right and left of the center line of the receiver.
- In addition, the signal may not be received if there is interference of light of fluorescent lights or strong sunlight.

7.3.2. Wired remote controller

1) Installing procedures

- (1) Select an installing position for the remote controller. (Fig. 7-6)

The temperature sensors are located on both remote controller and indoor unit.

▶ Procure the following parts locally:

- Two piece switch box
- Thin copper conduit tube
- Lock nuts and bushings
- Ⓐ Remote controller profile
- Ⓑ Required clearances surrounding the remote controller
- Ⓒ Installation pitch

- (2) Seal the service entrance for the remote controller cord with putty to prevent possible invasion of dew drops, water, cockroaches or worms. (Fig. 7-7)

Ⓐ For installation in the switch box:

Ⓑ For direct installation on the wall select one of the following:

- Prepare a hole through the wall to pass the remote controller cord (in order to run the remote controller cord from the back), then seal the hole with putty.
- Run the remote controller cord through the cutout in the upper case, then seal the cutout notch with putty similarly as above.

B-1. To lead the remote controller cord from the back of the controller:

B-2. To run the remote controller cord through the upper portion:

- (3) For direct installation on the wall

- Ⓒ Wall
- Ⓓ Conduit
- Ⓔ Lock nut
- Ⓕ Bushing
- Ⓖ Switch box
- Ⓗ Remote controller cord
- Ⓘ Seal with putty
- ⓵ Wood screw

2) Connecting procedures (Fig. 7-8)

- ① Connect the remote controller cord to the terminal block.

- Ⓐ To the terminal block on the indoor unit
- Ⓑ TB6 (No polarity)

3) Function selection of remote controller

If two remote controllers are connected, set one to "Main" and the other to "Sub". For setting procedures, refer to "Function selection of remote controller" in the operation manual for the indoor unit.

7. Electrical work

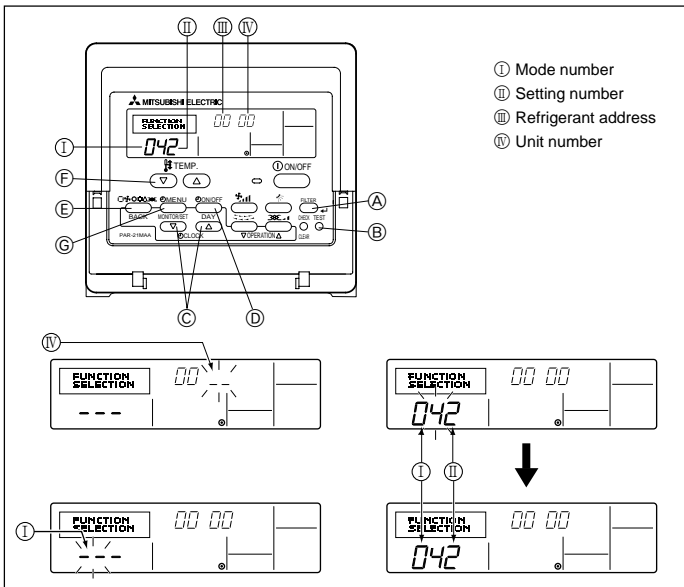

Fig. 7-9

7.4. Function settings

7.4.1 Function setting on the unit (Selecting the unit functions)

1) AUTO RESTART FUNCTION

Indoor controller board

This model is equipped with the AUTO RESTART FUNCTION.

(the DIP switch on the indoor controller board)

When the indoor unit is controlled with the remote controller, the operation mode, set temperature, and the fan speed are memorized by the indoor controller board. The auto restart function sets to work the moment the power has restored after power failure, then, the unit will restart automatically.

SW3

1	2	3	4	5	ON
					OFF

↑ Power failure automatic recovery

OFF : Not available

ON : Available (Initial setting)

* When the power supply returns, the air conditioner will start 3 minutes later.

2) Other functions

For wired remote controller only (Fig. 7-9)

Changing the power voltage setting

• Be sure to change the power voltage setting depending on the voltage used.

① Go to the function setting mode.

Switch OFF the remote controller.

Press the (A) and (B) buttons simultaneously and hold them for at least 2 seconds. FUNCTION will start to flash.

② Use the (C) button to set the refrigerant address (III) to 00.

③ Press (D) and [-] will start to flash in the unit number (IV) display.

④ Use the (C) button to set the unit number (IV) to 00.

⑤ Press the (E) MODE button to designate the refrigerant address/unit number. [-] will flash in the mode number (I) display momentarily.

⑥ Press the (F) buttons to set the mode number (I) to 04.

⑦ Press the (G) button and the current set setting number (II) will flash.

Use the (F) button to switch the setting number in response to the power supply voltage to be used.

Power supply voltage

240 V : setting number = 1

220 V, 230 V : setting number = 2

⑧ Press the MODE button (E) and mode and the setting number (I) and (II) will change to being on constantly and the contents of the setting can be confirmed.

⑨ Press the FILTER (A) and TEST RUN (B) buttons simultaneously for at least two seconds. The function selection screen will disappear momentarily and the air conditioner OFF display will appear.

Function table

Select unit number 00

Mode	Settings	Mode no.	Setting no.	Initial setting	Setting
Power failure automatic recovery *1 (AUTO RESTART FUNCTION)	Not available	01	1	*1	
	Available		2	*1	
Indoor temperature detecting	Indoor unit operating average	02	1	○	
	Set by indoor unit's remote controller		2		
	Remote controller's internal sensor		3		
LOSSNAY connectivity	Not Supported	03	1	○	
	Supported (indoor unit is not equipped with outdoor-air intake)		2		
	Supported (indoor unit is equipped with outdoor-air intake)		3		
Power voltage	240 V	04	1		
	220 V, 230 V		2	○	

Select unit numbers 01 to 03 or all units (AL)

Mode	Settings	Mode no.	Setting no.	Initial setting	Setting
Filter sign	100 Hr	07	1		
	2500 Hr		2	○	
	No filter sign indicator		3		

*1 For this model, mode no. 1 cannot be set using the remote controller. Set this mode using DIP switch SW3-1 of the indoor controller board.

8. Installing the grille

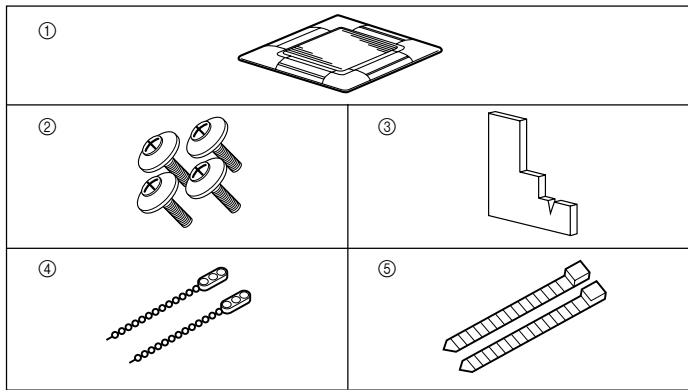

Fig. 8-1

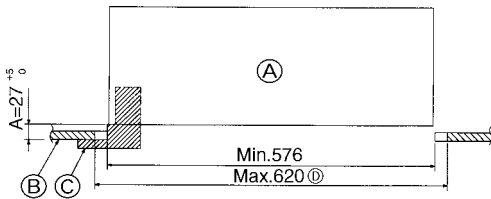

Fig. 8-2

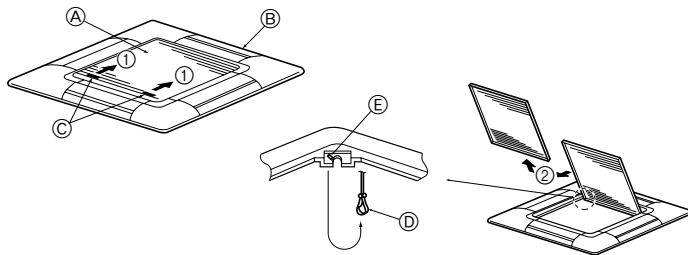

Fig. 8-3

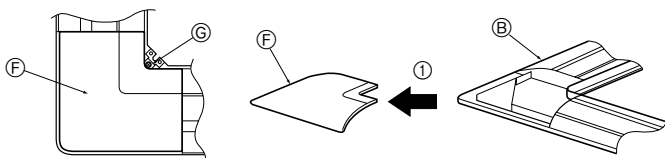

Fig. 8-4

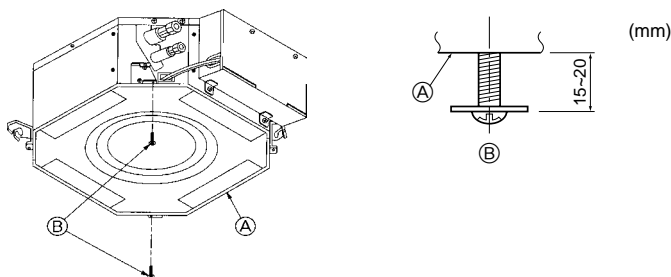

Fig. 8-5

8.1. Check the grille accessories (Fig. 8-1)

- The grille should be supplied with the following accessories.

	Accessory name	Q'ty	Remark
①	Grille	1	650 × 650 (mm)
②	Screw with washer	4	M5 × 0.8 × 25 (mm)
③	Gauge	1	
④	Fastener	2	
⑤	Band	2	

8.2. Preparing to attach the grille (Fig. 8-2)

- With the gauge supplied with this kit, adjust and check the positioning of the unit relative to the ceiling. If the unit is not properly positioned in the ceiling, there may be air leaks, condensation may form, or the up/down vanes may not operate correctly.
- Make sure that the opening in the ceiling is within the following tolerances: 576 × 576 - 620 × 620
- Make sure that step A is performed within 27-32 mm. Damage could result by failing to adhere to this range.
 - Ⓐ Main unit
 - Ⓑ Ceiling
 - Ⓒ Gauge (Accessory)
 - Ⓓ Ceiling opening dimensions

8.2.1. Removing the intake grille (Fig. 8-3)

- Slide the levers in the direction indicated by the arrow ① to open the intake grille.
- Unlatch the hook that secures the grille.
 - * Do not unlatch the hook for the intake grille.
- With the intake grille in the "open" position, remove the hinge of the intake grille from the grille as indicated by the arrow ②.

8.2.2. Removing the corner panel (Fig. 8-4)

- Remove the screw from the corner of the corner panel. Slide the corner panel as indicated by the arrow ① to remove the corner panel.
 - Ⓐ Intake grille
 - Ⓑ Grille
 - Ⓒ Intake grille levers
 - Ⓓ Grille hook
 - Ⓔ Hole for the grille's hook
 - Ⓕ Corner panel
 - Ⓖ Screw

8.3. Installing the grille

- Please pay attention because there is a restriction in the attachment position of the grille.

8.3.1. Preparations (Fig. 8-5)

- Install the two enclosed screws with washer in the main unit (at the corner refrigerant pipe area and at the opposite corner) as shown in the diagram.
 - Ⓐ Main unit
 - Ⓑ Detailed diagram of installed screw with washer (accessory).

8. Installing the grille

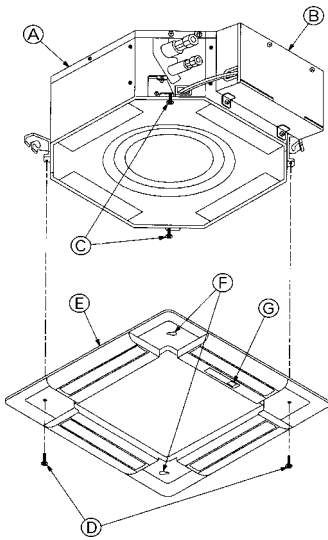

Fig. 8-6

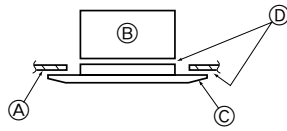

Fig. 8-7

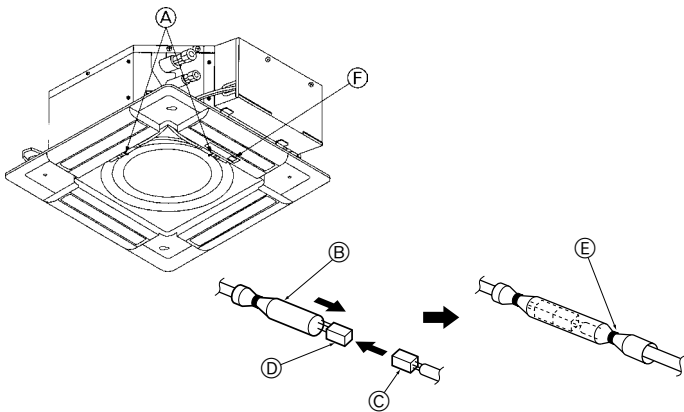

Fig. 8-8

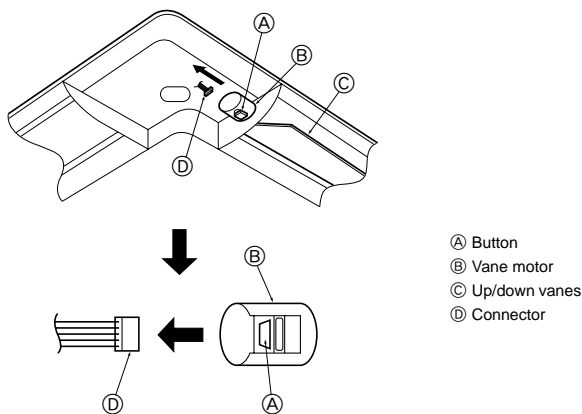

Fig. 8-9

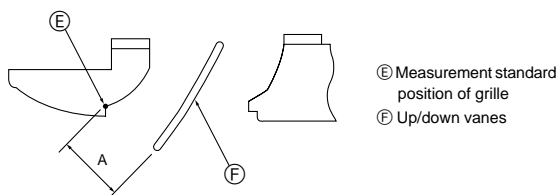

Fig. 8-10

8.3.2. Temporary installation of the grille (Fig. 8-6)

- Align the electric component box of the main unit and the receiver of the grille, and then temporarily secure the grille using the bell shaped holes.
 - * Make sure that the lead wiring of the grille does not get pinched between the grille and the main unit.

- Ⓐ Main unit
- Ⓑ Electric component box
- Ⓒ Screw with washer (for temporary use)
- Ⓓ Screw with washer (Accessory)
- Ⓔ Grille
- Ⓕ Bell shaped hole
- Ⓖ Receiver (For SLZ-KA25/KA35/KA50VAL)

8.3.3. Securing the grille (Fig. 8-7)

- Secure the grille to the main unit by tightening the previously installed two screws (with captive washer) as well as the two remaining screws (with captive washer).
 - * Make sure that there are no gaps between the main unit and the grille or the grille and the ceiling.

- Ⓐ Ceiling
- Ⓑ Main unit
- Ⓒ Grille
- Ⓓ Make sure that there are no gaps.

8.3.4. Wire connection (Fig. 8-8)

- Be sure to connect the unit to the connector (white:10-pole/red:9-pole). Next, attach the white glass tube that comes with the main unit so that the tube covers the connector. Close the opening of the glass tube with the band.
- Make sure that there is no slack in the each lead wire at the fastener on the grille.

- Ⓐ Fastener (Accessory)
- Ⓑ White glass tube
- Ⓒ Connector of the main unit
- Ⓓ Connector of the grille
- Ⓔ Band (Accessory)
- Ⓖ Receiver (For SLZ-KA25/KA35/KA50VAL)

8.4. Locking the up/down airflow direction (Fig. 8-9)

The vanes of the unit can be set and locked in on up or down orientation depending upon the environment of use.

- Set according to the preference of the customer.
 - The operation of the fixed up/down vanes and all automatic controls cannot be performed using the remote controller. In addition, the actual position of the vanes may differ from the position indicated on the remote controller.
- ① Turn off the main power switch.
 - Injuries and or an electrical shock may occur while the fan of the unit is rotating.
- ② Disconnect the connector for the vane motor of the vent that you want to lock.
 - (While pressing the button, remove the connector in the direction indicated by the arrow as shown in the diagram.) After removing the connector, insulate it with tape.
- ③ To adjust the desired airflow direction, slowly move the up/down vanes within the specified range. (Fig. 8-10)

Specified range

Up/down airflow direction	Horizontal 30°	Downward 45°	Downward 55°	Downward 70°
A (mm)	21	25	28	30

- The vanes can be set between 21 and 30 mm.

⚠ Caution:

Do not set the up/down vanes passed the specified range. Condensation could form on and drop from the ceiling, or the unit could malfunction.

8. Installing the grille

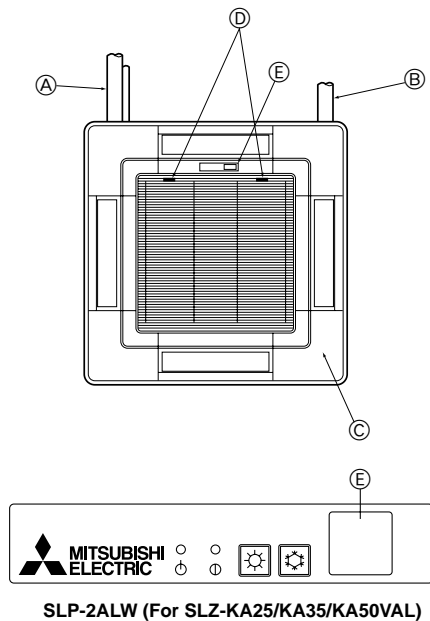

Fig. 8-11

8.5. Installing the intake grille (Fig. 8-11)

- Perform the procedure that is described in "8.2. Preparing to attach the grille" in reverse order to install the intake grille and the corner panel.
 - Ⓐ Refrigerant piping of the main unit
 - Ⓑ Drain piping of the main unit
 - Ⓒ Corner panel
 - * Installation in any position is possible.
 - Ⓓ Position of the levers on the intake grille when sent from the factory.
 - * Although the clips can be installed in any of four positions.
 - Ⓔ Receiver (For SLZ-KA25/KA35/KA50VAL)

8.6. Check

- Make sure that there is no gap between the unit and the grille, or between the grille and the surface of the ceiling. If there is any gap between the unit and the grille, or between the grille and the surface of the ceiling, it may cause dew to collect.
- Make sure that the wires have been securely connected.

9. Test run

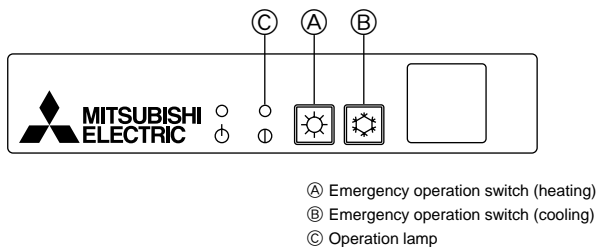

SLP-2ALW (For SLZ-KA25/KA35/KA50VAL)

Fig. 9-1

9.1. Before test run

- After installation of indoor and outdoor units, and piping and electric wiring work, recheck that the unit is free from leaks of refrigerant, loosened connections, and incorrect polarity.
- Measure an impedance between the power supply terminal block (L, N, ⊕) on the units and the ground with a 500 V Megger and check that it is equal to or greater than 1.0 MΩ.

9.2. Test run

9.2.1. For wireless remote controller (Fig. 9-1)

- Measure an impedance between the power supply terminal block on the outdoor unit and the ground with a 500 V Megger and check that it is equal to or greater than 1.0 MΩ.
- Before performing the test run, recheck for any wrong wiring.
 - Wrong wiring prevents normal operation or results in blown fuse disabling operation.
 - Perform test run in the following procedure.

Procedure

- Press the ❄️ button Ⓑ for more than 3 seconds to start the cooling operation.

If the operation lamp Ⓒ blinks every 0.5 seconds, inspect the indoor/outdoor connecting wire for miswiring.

- Check that the vanes operate properly when cool air is blown out.
- Press it once more, and the operation stops.
- Press the ☀️ button Ⓐ for more than 3 seconds to start the heating operation. Check that warm air blows out.
- In starting the heating operation, indoor unit fan may not operate to prevent blowing cool air. Please wait for a few minutes until the temperature of heat exchanger rises and warm air blows out.
- Press it once more, and the operation stops.

Checking the remote (infrared) signal reception

Press the ON/OFF button on the remote controller and check that an electronic sound is heard from the indoor unit. Press the ON/OFF button again to turn the air conditioner off.

Emergency operation (when wireless remote controller is lost)

The emergency operation can be started by pressing the button Ⓑ/Ⓐ (cooling/heating). When the button is once pressed, the unit will start the emergency operation at a fixed temperature setting of 24°C in cooling mode or heating mode.

Note:

- Emergency operation does not stop automatically.
- Although the thermostat is forcibly set to on during the test run, the temperature is set to 24°C during emergency operation and the thermostat operates according to the room temperature.

If the indoor unit is operated with the remote controller, both the test run and the emergency operation are released by commands from the remote controller.

Once the compressor stops, the restart preventive device operates so the compressor will not operate for three minutes to protect the air conditioner.

9. Test run

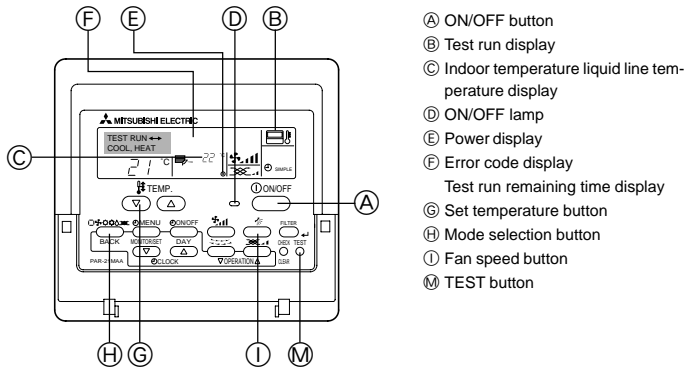

Fig. 9-2

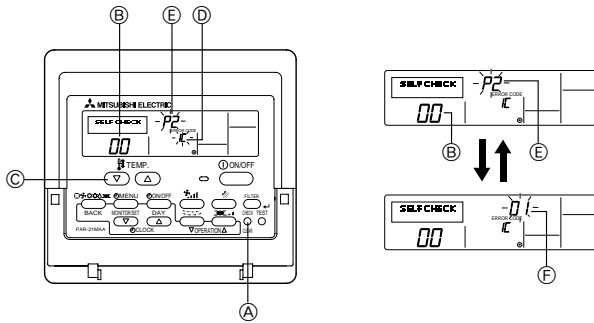
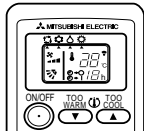

Fig. 9-3



The OPERATION INDICATOR lamp comes on regardless of the remote controller display.

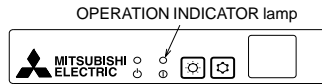

Fig. 9-4

9.2.2. Wired remote controller (Fig. 9-2)

- ① Turn on the power at least 12 hours before the test run.
- ② Press the [TEST] button twice. → "TEST RUN" liquid crystal display
- ③ Press the [Mode selection] button. → Make sure that wind is blown out.
- ④ Press the [Mode selection] button and switch to the cooling (or heating) mode. → Make sure that cold (or warm) wind is blown out.
- ⑤ Press the [Fan speed] button. → Make sure that the wind speed is switched.
- ⑥ Check operation of the outdoor unit fan.
- ⑦ Release test run by pressing the [ON/OFF] button. → Stop
- ⑧ Register a telephone number.

The telephone number of the repair shop, sales office, etc., to contact if an error occurs can be registered in the remote controller. The telephone number will be displayed when an error occurs. For registration procedures, refer to the operation manual for the indoor unit.

9.3. Self-check

9.3.1. Wired remote controller (Fig. 9-3)

- ① Turn on the power.
- ② Press the [CHECK] button twice.
- ③ Set refrigerant address with [TEMP] button if system control is used.
- ④ Press the [ON/OFF] button to stop the self-check.

- A CHECK button
- B Refrigerant address
- C TEMP. button
- D IC: Indoor unit
- E OC: Outdoor unit
- F Check code
- G Unit address

9.3.2. Wireless remote controller (Fig. 9-4)

- ① Turn ON the power.
- ② While pressing both the MODE SELECT button and TOO COOL button on the remote controller at the same time, press the RESET button.
- ③ Release the RESET button.
- ④ Release the other two buttons. After three seconds, all items in the LCD are displayed.
- ⑤ Transmit the signal of remote controller by pressing the OPERATE/STOP (ON/OFF) button on the remote controller.
(The above procedure allows OPERATION INDICATOR lamp to indicate the failure-mode.)
- ⑥ Transmit the signal of remote controller by pressing the OPERATE/STOP (ON/OFF) button to stop the self-check.

9. Test run

- Refer to the following tables for details on the check codes.

[Output pattern A]

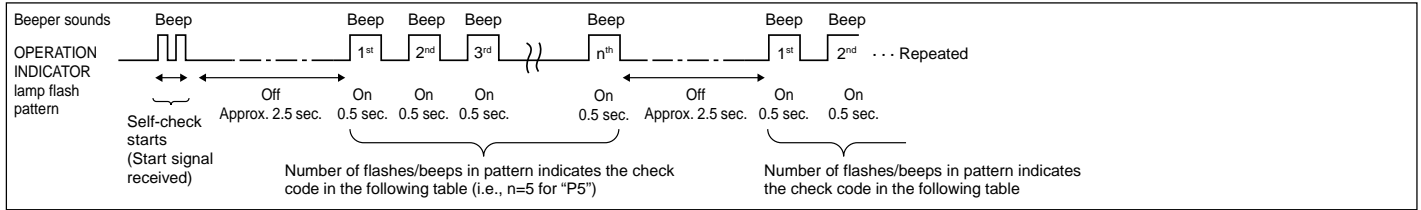

[Output pattern B]

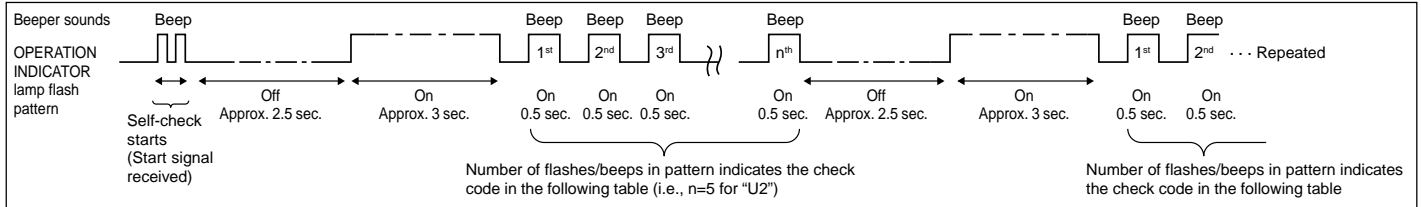

[Output pattern A] Errors detected by indoor unit

Wireless remote controller	Wired remote controller	Symptom	Remark
Beeper sounds/OPERATION INDICATOR lamp flashes (Number of times)	Check code		
1	P1	Intake sensor error	For details, check the LED display of the outdoor controller board.
2	P2	Pipe (TH2) sensor error	
	P9	Pipe (TH5) sensor error	
3	E6, E7	Indoor/outdoor unit communication error	
4	P4	Drain sensor error	
5	P5	Drain pump error	
	PA	Forced compressor error	
6	P6	Freezing/Overheating safeguard operation	
7	EE	Communication error between indoor and outdoor units	
8	P8	Pipe temperature error	
9	E4	Remote controller signal receiving error	
10	—	—	
11	—	—	
12	Fb	Indoor unit control system error (memory error, etc.)	

[Output pattern B] Errors detected by unit other than indoor unit (outdoor unit, etc.)

Wireless remote controller	Wired remote controller	Symptom	Remark
Beeper sounds/OPERATION INDICATOR lamp flashes (Number of times)	Check code		
1	E9	Indoor/outdoor unit communication error (Transmitting error) (Outdoor unit)	For details, check the LED display of the outdoor controller board.
2	UP	Compressor overcurrent interruption	
3	U3, U4	Open/short of outdoor unit thermistors	
4	UF	Compressor overcurrent interruption (When compressor locked)	
5	U2	Abnormal high discharging temperature/49C worked/insufficient refrigerant	
6	U1, Ud	Abnormal high pressure (63H worked)/Overheating safeguard operation	
7	U5	Abnormal temperature of heat sink	
8	U8	Outdoor unit fan safeguard stop	
9	U6	Compressor overcurrent interruption/Abnormal of power module	
10	U7	Abnormality of super heat due to low discharge temperature	
11	U9, UH	Abnormality such as overvoltage or voltage shortage and abnormal synchronous signal to main circuit/Current sensor error	
12	—	—	
13	—	—	
14	Others	Other errors (Refer to the technical manual for the outdoor unit.)	

*1 If the beeper does not sound again after the initial two beeps to confirm the self-check start signal was received and the OPERATION INDICATOR lamp does not come on, there are no error records.

2 If the beeper sounds three times continuously "beep, beep, beep (0.4 + 0.4 + 0.4 sec.)" after the initial two beeps to confirm the self-check start signal was received, the specified refrigerant address is incorrect.

9. Test run

- On wireless remote controller
The continuous buzzer sounds from receiving section of indoor unit.
Blink of operation lamp
- On wired remote controller
Check code displayed in the LCD.
- If the unit cannot be operated properly after the above test run has been performed, refer to the following table to remove the cause.

Symptom		Cause
Wired remote controller		
PLEASE WAIT	For about 2 minutes following power-on	• For about 2 minutes following power-on, operation of the remote controller is not possible due to system start-up. (Correct operation)
PLEASE WAIT → Error code	After about 2 minutes has expired following power-on	• Connector for the outdoor unit's protection device is not connected. • Reverse or open phase wiring for the outdoor unit's power terminal block
Display messages do not appear even when operation switch is turned ON (operation lamp does not light up).		• Incorrect wiring between indoor and outdoor units (incorrect polarity of S1, S2, S3) • Remote controller wire short

On the wireless remote controller with condition above, following phenomena takes place.

- No signals from the remote controller are accepted.
- OPE lamp is blinking.
- The buzzer makes a short piping sound.

Note:

Operation is not possible for about 30 seconds after cancellation of function selection. (Correct operation)

For description of each LED (LED1, 2, 3) provided on the indoor controller, refer to the following table.

LED1 (power for microcomputer)	Indicates whether control power is supplied. Make sure that this LED is always lit.
LED2 (power for wired remote controller)	Indicates whether power is supplied to the wired remote controller.
LED3 (communication between indoor and outdoor units)	Indicates state of communication between the indoor and outdoor units. Make sure that this LED is always blinking.

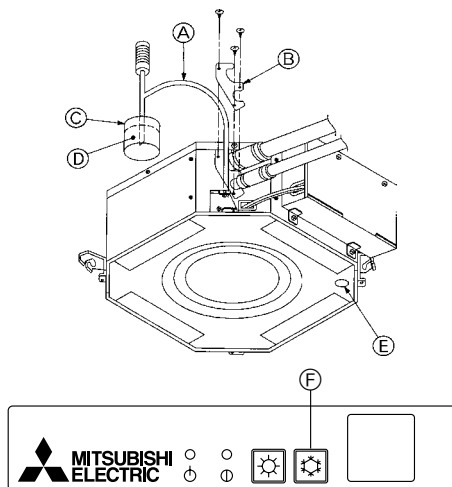

SLP-2ALW (For SLZ-KA25/KA35/KA50VAL)

Fig. 9-5

9.4. Check drainage

9.4.1. For wireless remote controller (Fig. 9-5)

- During the test run, ensure the water is being properly drained out and that no water is leaking from joints.
 - Always check this during installation even if the unit is not required to provide cooling/drying at that time.
 - Similarly, check the drainage before finishing ceiling installation in a new premises.
- (1) Remove the cover of the water supply inlet and add about 1000 cc of water using a water supply pump etc. During this process, be careful not to spray water into the drain pump mechanism.
 - (2) Switching on emergency operation switch (cooling) on the grille.
 - (3) Confirm that water is being drained out through the drainage outlet.
 - (4) After checking the drainage, ensure that the cover is replaced and the power supply is isolated.
 - (5) After confirming the drainage system is functioning, replace the drain plug.

- Ⓐ Insert the pump end 3 to 5 cm
- Ⓑ Cover of water supply inlet
- Ⓒ About 1000 cc
- Ⓓ Water
- Ⓔ Drain plug
- Ⓕ Emergency operation switch (cooling)

9.4.2. For wired remote controller

- (1) Remove the cover of the water supply inlet and add about 1000 cc of water using a water supply pump etc. During this process, be careful not to spray water into the drain pump mechanism.
- (2) Confirm that water is being drained out through the drainage outlet, after switching over from remote control mode to test run mode (cooling mode).
- (3) After checking the drainage, ensure that the cover is replaced and the power supply is isolated.
- (4) After confirming the drainage system is functioning, replace the drain plug.

This product is designed and intended for use in the residential,
commercial and light-industrial environment.

The product at hand is based on the following EU regulations:

- Low Voltage Directive 2006/95/ EC
- Electromagnetic Compatibility Directive 2004/108/ EC

Please be sure to put the contact address/telephone number on
this manual before handing it to the customer.

 **MITSUBISHI ELECTRIC CORPORATION**

HEAD OFFICE: TOKYO BLDG., 2-7-3, MARUNOUCHI, CHIYODA-KU, TOKYO 100-8310, JAPAN

Authorized representative in EU: MITSUBISHI ELECTRIC EUROPE.B.V.

HARMAN HOUSE, 1 GEORGE STREET, UXBRIDGE, MIDDLESEX, UB8 1QQ, U.K.