

Air Conditioning

Product Information

SLZ-KA35VAQ : Inverter Heat Pump

R410A 4-Way Blow Ceiling Cassette System

Mr.SLIM™



The SLZ series is perfect for both residential and small business applications, as it offers inverter technology alongside quiet operation. The compact size of this unit is ideal for 600 x 600mm ceilings and with a height of 208mm, this lightweight unit makes installation a breeze. This unit also comes complete with a long life filter that will last for approximately 2,500 hours.

FEATURES



INDOOR

Heating Capacity (kW) (nominal)	3.9 (0.9 - 5)
Cooling Capacity (kW) (nominal)	3.5 (1 - 3.9)
Heating Capacity (kW) (UK)	3.3 (0.75 - 4.15)
Cooling Capacity (kW) (UK)	3.45 (1 - 3.85)
SHF (nominal and UK)	0.77
COP / EER (nominal)	3.47 / 3.36
SCOP / SEER	3.5 / 4.7
Energy Efficiency Class - Heating / Cooling	A / B
Pipe Size Gas (mm [in])	9.52 (3/8")
Pipe Size Liquid (mm [in])	6.35 (1/4")
Airflow (m ³ /min) Lo-Mi-Hi	8 - 9 - 11
Sound Pressure Level (dBA) Lo-Mi-Hi	29 - 33 - 38
Sound Power Level (dBA) Cooling	57
Weight (kg)	17
Dimensions (mm) Width x Depth x Height	570(650) x 570(650) x 235(20)

Electrical Supply	FED BY OUTDOOR UNIT
Phase	SINGLE
Fuse Rating (BS88) - HRC (A)	6
Interconnecting Cable No. Cores	4

OUTDOOR

Sound Pressure Level (dBA) Heating / Cooling	50 / 49
Sound Power Level (dBA) Cooling	62
Weight (kg)	35
Dimensions (mm) Width x Depth x Height	800 x 285 x 550
Electrical Supply	220-240V, 50HZ
Phase	SINGLE
System Power Input (kW) - Heating / Cooling (nominal)	1.12 / 1.04
System Power Input (kW) - Heating / Cooling (UK)	1.02 / 0.83
Starting Current (A)	5
System Running Current (A) [MAX] - Heating / Cooling	4.77 / 4.75 [8.6]
Fuse Rating (BS88) - HRC (A)	10
Mains Cable No. Cores	3
Max Pipe Length (m)	20
Max Height Difference (m)	12
Charge R410A (kg) - pre charged length (m)	1.15 - 7

DIMENSIONS

SLZ-KA35VAQ

Lower View >

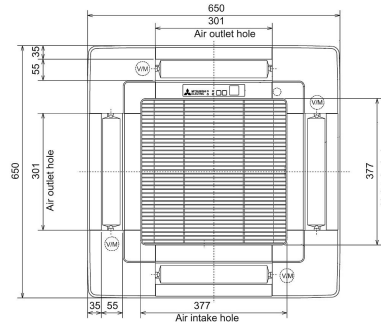

Side View >

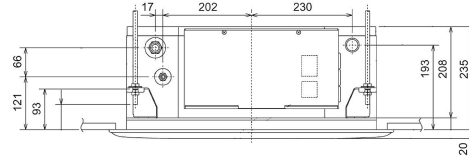

DIMENSIONS

SUZ-KA35VA3

Upper View >

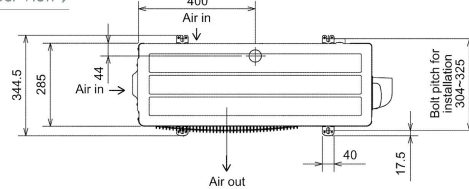

Front View >

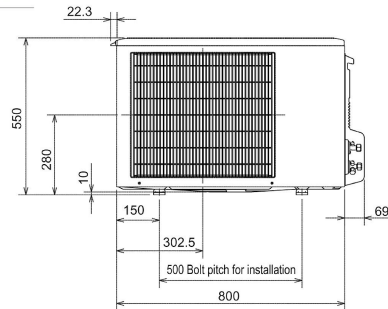

Side View >

