

PARTS CATALOG

R410A

Outdoor unit

[model name]

[Service Ref.]

PUHZ-RP35VHA4

PUHZ-RP35VHA4

PUHZ-RP50VHA4

PUHZ-RP50VHA4

PUHZ-RP60VHA4

PUHZ-RP60VHA4

PUHZ-RP71VHA4

PUHZ-RP71VHA4

PUHZ-RP100VKA

PUHZ-RP100VKA

PUHZ-RP125VKA

PUHZ-RP125VKA

PUHZ-RP140VKA

PUHZ-RP140VKA

PUHZ-RP100YKA

PUHZ-RP100YKA

PUHZ-RP125YKA

PUHZ-RP125YKA

PUHZ-RP140YKA

PUHZ-RP140YKA

PUHZ-RP200YKA

PUHZ-RP200YKA

PUHZ-RP250YKA

PUHZ-RP250YKA

Note:

- RoHS compliant products have <G> mark on the spec name plate.

CONTENTS

1. RoHS PARTS LIST 2

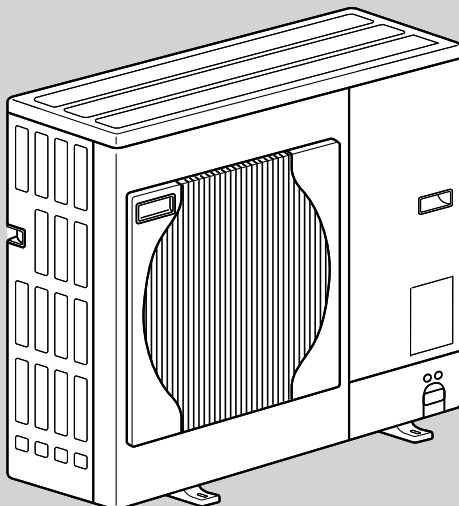
SERVICE MANUAL (OCH451)

 PUHZ-RP60VHA4
 PUHZ-RP71VHA4

FUNCTIONAL AND ELECTRICAL PARTS

PUHZ-RP35VHA4

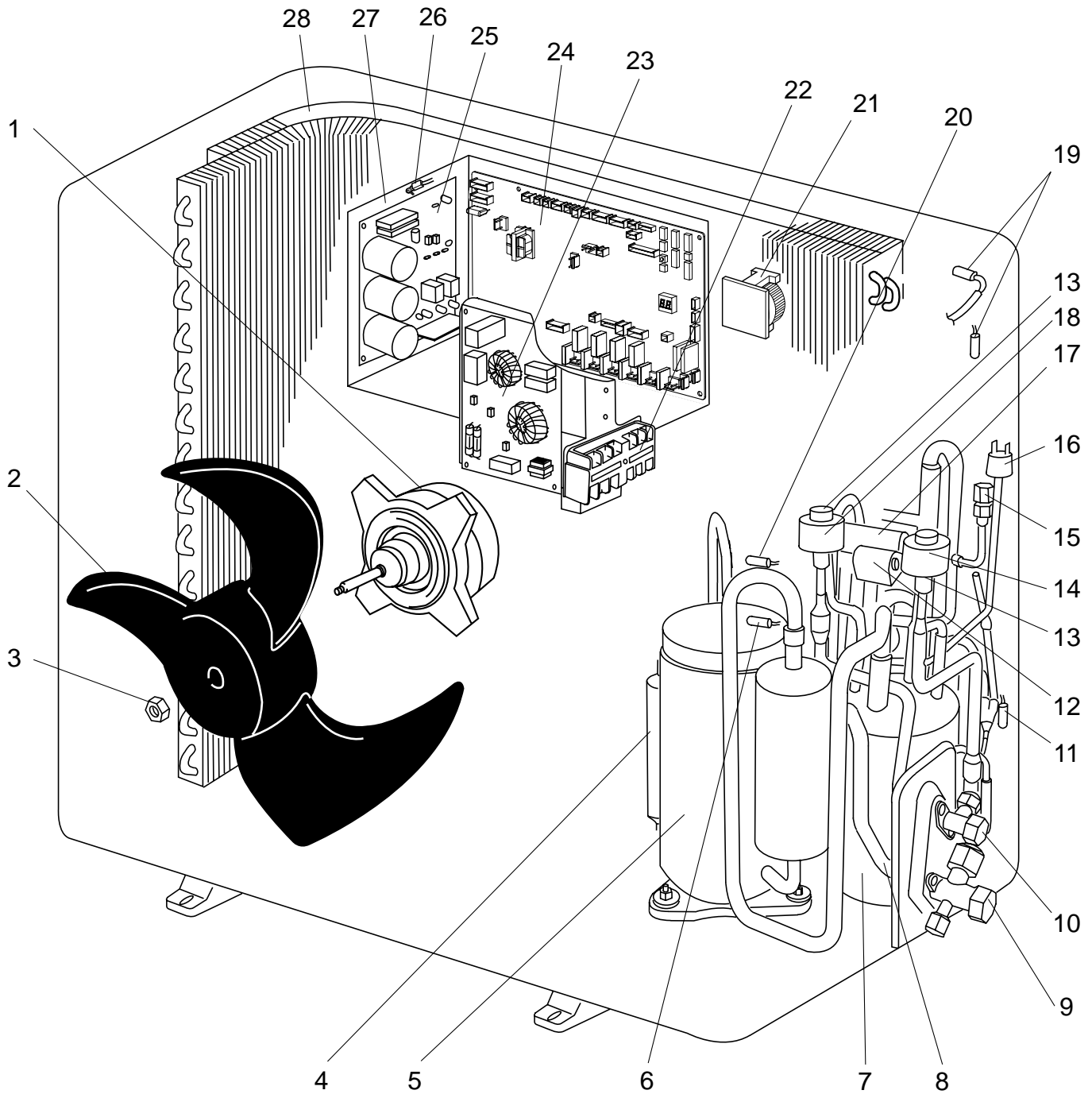
PUHZ-RP50VHA4



Part numbers that are circled are not shown in the figure.

No.	RoHS	Part No.	Part Name	Specification	Q'ty/set		Remarks (Drawing No.)	Wiring Diagram Symbol	Recom- mended Q'ty
					PUHZ-RP35, 50	VHA4			
1	G	R01 E47 221	FAN MOTOR			1		MF1	
2	G	R01 E07 115	PROPELLER FAN			1			
3	G	R01 E08 097	NUT			1			
4	G	R01 E25 467	MUFFLER			1			
5	G	T92 574 280	COMPRESSOR	SNB130FGCH		1	Including RUBBER MOUNT	MC	
6	G	T7W E10 201	SHELL THERMISTOR			1		TH32	
7	G	R01 E41 440	POWER RECEIVER			1			
8	G	R01 31L 450	STRAINER			1			
9	G	R01 E23 410	STOP VALVE (GAS)	1/2		1			
10	G	R01 E10 411	STOP VALVE (LIQUID)	1/4		1			
11	G	R01 E98 202	THERMISTOR (OUTDOOR PIPE)			1		TH3	
12	G	T7W E34 242	SOLENOID COIL <4-WAY VALVE>			1		21S4	
13	G	R01 E75 401	LEV			2			
14	G	R01 E36 242	LEV COIL			1		LEV(A)	
15	G	R01 E24 413	CHARGE PLUG			1			
16	G	R01 E06 208	HIGH PRESUURE SWITCH			1		63H	
17	G	R01 E29 403	4-WAY VALVE			1			
18	G	R01 E37 242	LEV COIL			1		LEV(B)	
19	G	R01 E97 202	THERMISTOR (OUTDOOR 2PHASE PIPE, OUTDOOR)			1		TH6, 7	
20	G	R01 E18 201	THERMISTOR (DISCHARGE)			1		TH4	
21	G	R01 E22 259	REACTOR			1		ACL	
22	G	T7W E28 716	TERMINAL BLOCK	6P (L,N,0,S1,S2,S3)		1		TB1	
23	G	T7W E20 346	NOISE FILTER			1		N.F.	
24	G	T7W E80 315	CONTROLLER CIRCUIT BOARD			1		C.B.	
25	G	T7W E54 313	POWER CIRCUIT BOARD			1		P.B.	
26	G	R01 E99 202	THERMISTOR (HEATSINK)			1		TH8	
27	G	—	ELECTRICAL PARTS BOX			1	(RG00N040G12)		
28	G	R01 E88 408	HEAT EXCHANGER			1			
29	G	R01 E06 239	FUSE	250V 6.3A		4		F1,2,3,4	
30	G	T7W E51 202	THERMISTOR (OUTDOOR PIPE)			1		TH33	

FUNCTIONAL AND ELECTRICAL PARTS
PUHZ-RP60VHA4
PUHZ-RP71VHA4

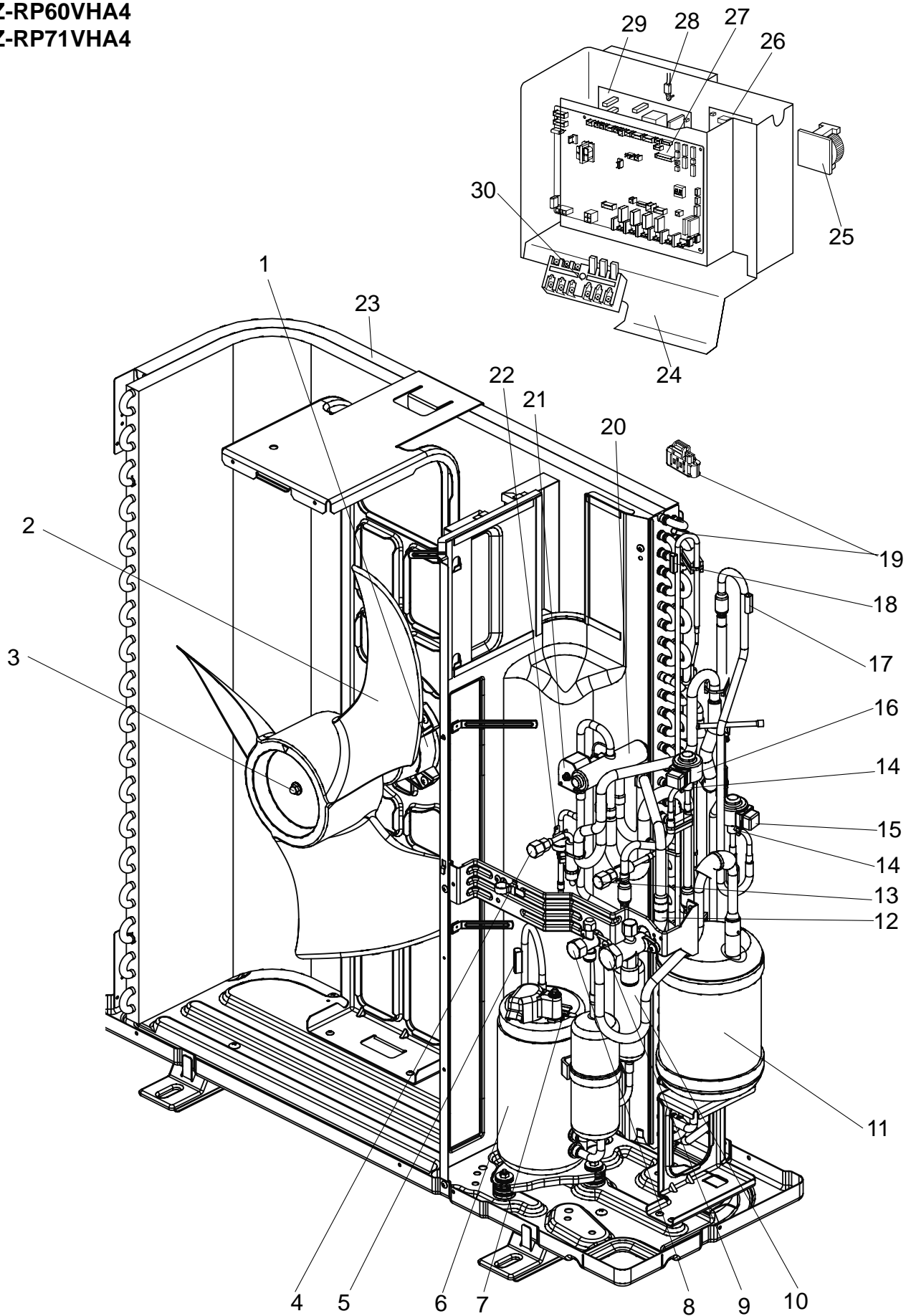

Part numbers that are circled are not shown in the figure.

No.	RoHS	Part No.	Part Name	Specification	Q'ty/set		Remarks (Drawing No.)	Wiring Diagram Symbol	Recom- mended Q'ty
					PUHZ-RP60, 71	VHA4			
					1	G			
2	G	R01 E08 115	PROPELLER FAN		1				
3	G	R01 E09 097	NUT		1				
4	G	R01 E24 413	CHARGE PLUG		1				
5	G	T7W E04 201	THERMISTOR (DISCHARGE)		1		TH4		
6	G	T92 576 280	COMPRESSOR	SNB172FDHM1	1	Including RUBBER MOUNT	MC		
7	G	T7W E11 201	SHELL THERMISTOR		1		TH32		
8	G	R01 E25 410	STOP VALVE	3/8	1				
9	G	R01 E24 410	STOP VALVE	5/8	1				
10	G	R01 E25 467	MUFFLER						
11	G	R01 E42 440	POWER RECEIVER		1				
12	G	R01 32L 450	STRAINER		1				
13	G	T7W E09 413	CHARGE PLUG		1				
14	G	R01 E79 401	LEV		2				
15	G	R01 E85 242	LEV COIL		1		LEV(A)		
16	G	T7W E46 242	LEV COIL		1		LEV(B)		
17	G	T7W E52 202	THERMISTOR (OUTDOOR PIPE)		1		TH33		
18	G	R01 N03 202	THERMISTOR (OUTDOOR PIPE)		1		TH3		
19	G	R01 E94 202	THERMISTOR (OUTDOOR 2PHASE PIPE, OUTDOOR)		1		TH6, 7		
20	G	R01 E13 403	4-WAY VALVE		1				
21	G	T7W E29 242	SOLENOID COIL <4-WAY VALVE>		1		21S4		
22	G	R01 E06 208	HIGH PRESSURE SWITCH		1		63H		
23	G	R01 E83 408	HEAT EXCHANGER		1				
24	G	—	ELECTRICAL PARTS BOX		1	(BK00B055G21)			
25	G	R01 E33 259	REACTOR		1		ACL		
26	G	T7W E21 346	NOISE FILTER CIRCUIT BOARD		1		N.F.		
27	G	T7W E80 315	CONTROLLER CIRCUIT BOARD		1		C.B.		
28	G	R01 E99 202	THERMISTOR (HEATSINK)		1		TH8		
29	G	T7W E55 313	POWER CIRCUIT BOARD		1		P.B.		
30	G	T7W E29 716	TERMINAL BLOCK	6P (L,N,0,S1,S2,S3)	1		TB1		
31	G	R01 E06 239	FUSE	250V 6.3A	4		F1,2,3,4		

FUNCTIONAL AND ELECTRICAL PARTS
PUHZ-RP100VKA
PUHZ-RP125VKA

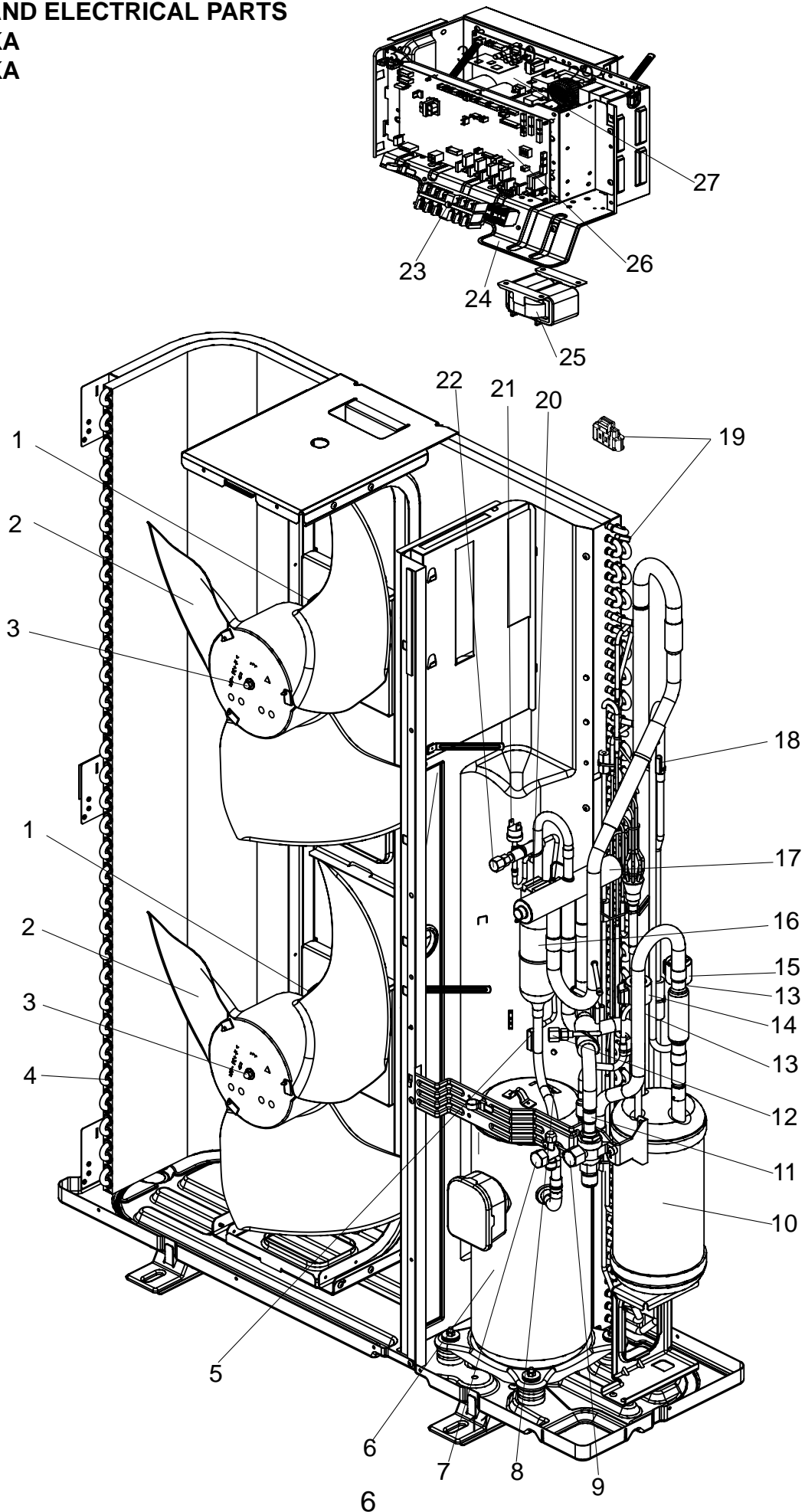

Part numbers that are circled are not shown in the figures.

No.	RoHS	Part No.	Part Name	Specification	Q'ty/set	Remarks (Drawing No.)	Wiring Diagram Symbol	Recom- mended Q'ty
					PUHZ-RP100VKA PUHZ-RP125VKA			
1	G	R01 E50 221	FAN MOTOR		2		MF1,2	
2	G	R01 E10 115	PROPELLER FAN		2			
3	G	R01 E09 097	NUT		2			
4	G	R01 H10 408	HEAT EXCHANGER		1			
5	G	T7W E04 201	THERMISTOR (DISCHARGE)		1		TH4	
6	G	T97 415 773	COMPRESSOR	ANB33FDUMT	1	With RUBBER MOUNTS	MC	
7	G	R01 E25 410	STOP VALVE	3/8	1			
8	G	T7W E11 201	THERMISTOR (SHELL)		1		TH32	
9	G	R01 E12 410	BALL VALVE	5/8	1			
10	G	R01 E43 440	POWER RECEIVER		1			
11	G	R01 32L 450	STRAINER		1			
12	G	R01 E24 413	CHARGE PLUG		1			
13	G	R01 H20 401	LEV		2			
14	G	R01 E88 242	LEV COIL		1		LEV(B)	
15	G	R01 E86 242	LEV COIL		1		LEV(A)	
16	G	R01 E10 467	MUFFLER		1			
17	G	R01 E15 403	4-WAY VALVE		1			
18	G	T7W E52 202	THERMISTOR (OUTDOOR PIPE)		1		TH33	
19	G	R01 E94 202	THERMISTOR (OUTDOOR 2PHASE PIPE, OUTDOOR)		1		TH6,7	
20	G	T7W E41 242	SOLENOID COIL <4-WAY VALVE>		1		21S4	
21	G	R01 E06 208	HIGH PRESSURE SWITCH		1		63H	
22	G	T7W E09 413	CHARGE PLUG		1			
23	G	T7W E29 716	TERMINAL BLOCK	6P (L,N,0,S1,S2,S3)	1		TB1	
24	G	—	ELECTRICAL PARTS BOX		1	(BK00B055G44)		
25	G	T7W E20 259	REACTOR		1		DCL	
26	G	T7W E81 315	CONTROLLER CIRCUIT BOARD		1		C.B.	
27	G	T7W E56 313	POWER CIRCUIT BOARD		1		P.B.	
28	G	R01 E06 239	FUSE	250V 6.3A	4		F1,2,3,4	
29	G	R01 H00 202	THERMISTOR (OUTDOOR PIPE)		1		TH3	
30	G	R01 E20 254	MAIN SMOOTHING CAPACITOR		1		CB	

FUNCTIONAL AND ELECTRICAL PARTS
PUHZ-RP100YKA
PUHZ-RP125YKA

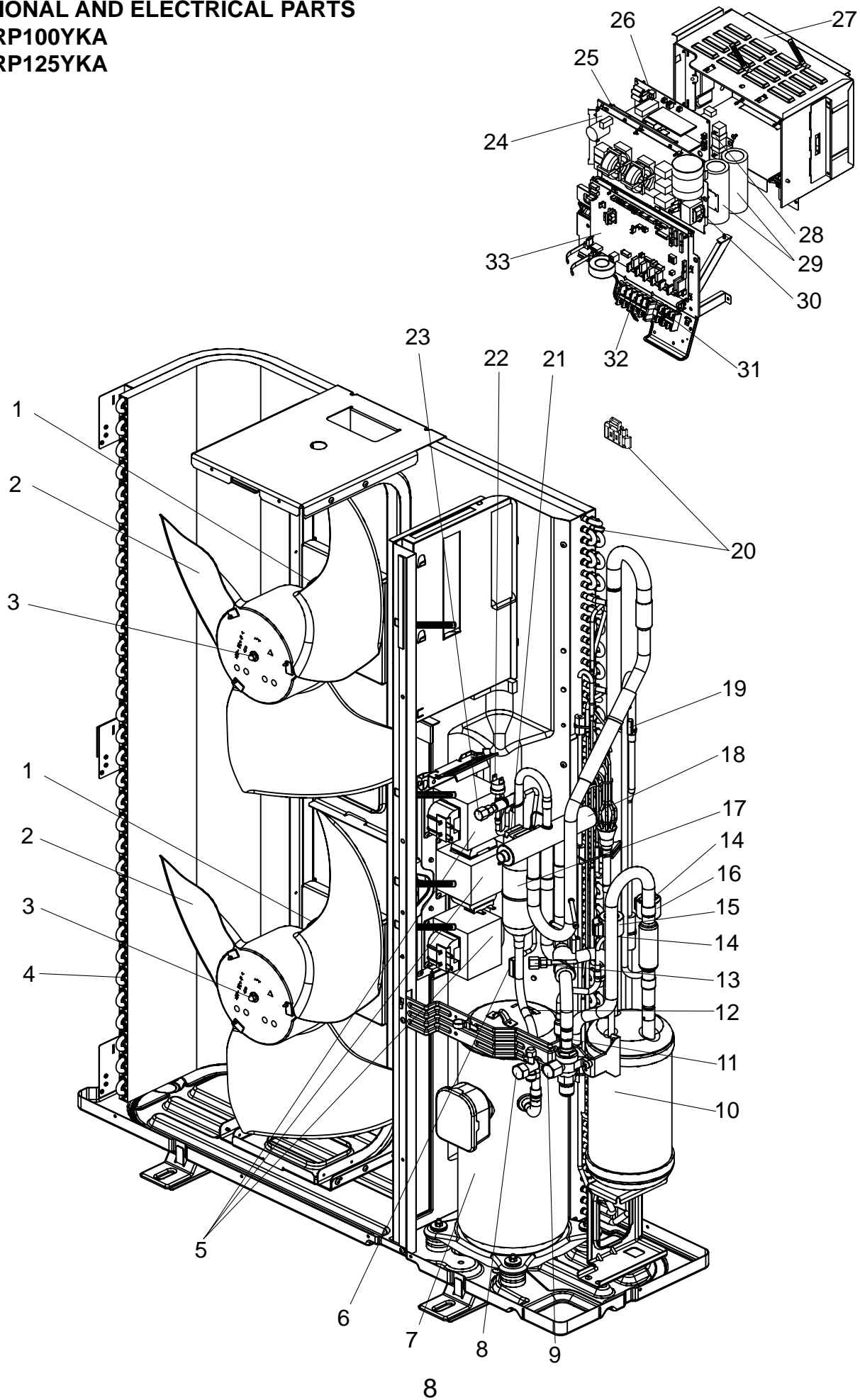

Part numbers that are circled are not shown in the figures.

No.	R/CHS	Part No.	Part Name	Specification	Q'ty/set		Remarks (Drawing No.)	Wiring Diagram Symbol	Recom- mended Q'ty
					PUHZ-RP-YKA				
					100	125			
1	G	R01 E50 221	FAN MOTOR		2	2		MF1,2	
2	G	R01 E10 115	PROPELLER FAN		2	2			
3	G	R01 E09 097	NUT		2	2			
4	G	R01 H10 408	HEAT EXCHANGER		1	1			
5	G	T7W E21 259	REACTOR		3			ACL1,2,3	
	G	T7W E22 259	REACTOR			3		ACL1,2,3	
6	G	T7W E04 201	THERMISTOR (DISCHARGE)		1	1		TH4	
7	G	T97 415 774	COMPRESSOR	ANB33FDVMT	1	1	With RUBBER MOUNTS	MC	
8	G	R01 E25 410	STOP VALVE	3/8	1	1			
9	G	R01 E12 410	BALL VALVE	5/8	1	1			
10	G	R01 E43 440	POWER RECEIVER		1	1			
11	G	R01 32L 450	STRAINER		1	1			
12	G	T7W E11 201	THERMISTOR (SHELL)		1	1		TH32	
13	G	R01 E24 413	CHARGE PLUG		1	1			
14	G	R01 H20 401	LEV		2	2			
15	G	R01 E49 242	LEV COIL		1	1		LEV(B)	
16	G	R01 E50 242	LEV COIL		1	1		LEV(A)	
17	G	R01 E10 467	MUFFLER		1	1			
18	G	R01 E15 403	4-WAY VALVE		1	1			
19	G	T7W E52 202	THERMISTOR (OUTDOOR PIPE)		1	1		TH33	
20	G	R01 H01 202	THERMISTOR (OUTDOOR 2PHASE PIPE, OUTDOOR)		1	1		TH6,7	
21	G	T7W E41 242	SOLENOID COIL <4-WAY VALVE>		1	1		21S4	
22	G	R01 E06 208	HIGH PRESUURE SWITCH		1	1		63H	
23	G	T7W E09 413	CHARGE PLUG		1	1			
24	G	T7W E23 346	NOISE FILTER CIRCUIT BOARD		1	1		N.F.	
25	G	T7W E75 310	CONVERTER CIRCUIT BOARD		1	1		CONV.B.	
26	G	T7W E58 313	POWER CIRCUIT BOARD		1	1		P.B.	
27	G	—	ELECTRICAL PARTS BOX		1	1	(BK00C410G09)		
28	G	R01 E10 233	RESISTOR		1	1		RS	
29	G	R01 E02 254	MAIN SMOOTHING CAPACITOR		2	2		CB1,CB2	
30	G	R01 E31 259	REACTOR		1	1		ACL4	
31	G	R01 E18 246	TERMINAL BLOCK	3P (S1,S2,S3)	1	1		TB2	
32	G	T7W E30 716	TERMINAL BLOCK	5P (L1,L2,L3,N,⊙)	1	1		TB1	
33	G	T7W E81 315	CONTROLLER CIRCUIT BOARD		1	1		C.B.	
34	G	R01 E06 239	FUSE	250V 6.3A	4	4		F1,2,3,4	
35	G	R01 H00 202	THERMISTOR (OUTDOOR PIPE)		1	1		TH3	
36	G	T7W E10 254	CAPACITOR		1	1		CK	

FUNCTIONAL AND ELECTRICAL PARTS PUHZ-RP140VKA

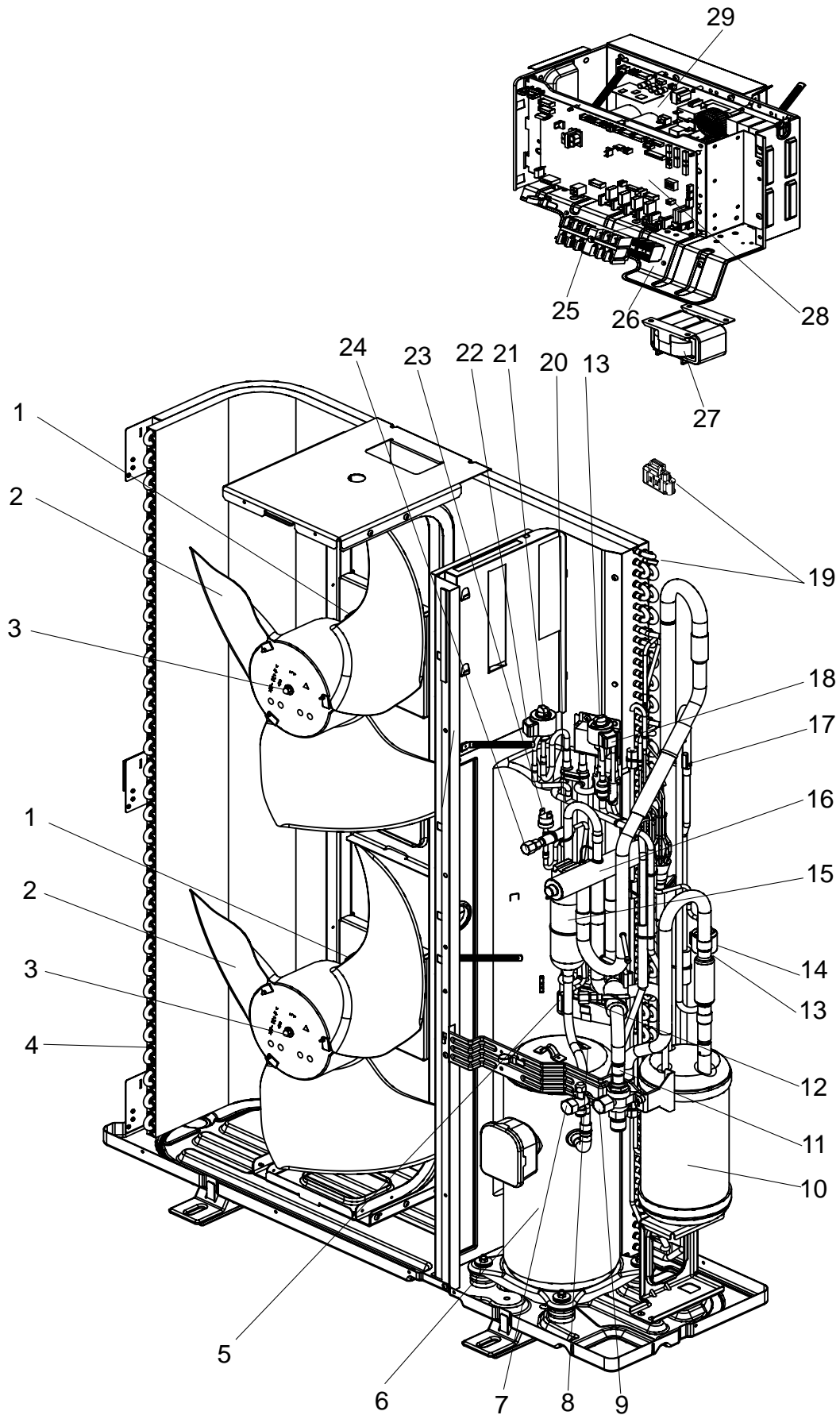

Part numbers that are circled are not shown in the figures.

No.	RoHS	Part No.	Part Name	Specification	Q'ty/set	Remarks (Drawing No.)	Wiring Diagram Symbol	Recom- mended Q'ty
					PUHZ-RP140VKA			
1	G	R01 E50 221	FAN MOTOR		2		MF1,2	
2	G	R01 E10 115	PROPELLER FAN		2			
3	G	R01 E09 097	NUT		2			
4	G	R01 H10 408	HEAT EXCHANGER		1			
5	G	T7W E04 201	THERMISTOR (DISCHARGE)		1		21S4	
6	G	T97 415 775	COMPRESSOR	ANB42FDWMT	1	With RUBBER MOUNTS	MC	
7	G	R01 E25 410	STOP VALVE	3/8	1			
8	G	T7W E11 201	THERMISTOR (SHELL)		1		TH32	
9	G	R01 E12 410	BALL VALVE	5/8	1			
10	G	R01 E43 440	POWER RECEIVER		1			
11	G	R01 32L 450	STRAINER		1			
12	G	R01 E24 413	CHARGE PLUG		1			
13	G	R01 H20 401	LEV		2			
14	G	R01 E86 242	LEV COIL		1		LEV(A)	
15	G	R01 E10 467	MUFFLER		1			
16	G	R01 E15 403	4-WAY VALVE		1			
17	G	T7W E52 202	THERMISTOR (OUTDOOR PIPE)		1		TH33	
18	G	R01 E49 242	LEV COIL		1		LEV(B)	
19	G	R01 E94 202	THERMISTOR (OUTDOOR 2PHASE PIPE, OUTDOOR)		1		TH6,7	
20	G	T7W E41 242	SOLENOID COIL <4-WAY VALVE>		1		21S4	
21	G	T7W E26 401	LEV		1			
22	G	R01 E68 242	LEV COIL		1		LEV(C)	
23	G	R01 E06 208	HIGH PRESSURE SWITCH		1		63H	
24	G	T7W E09 413	CHARGE PLUG		1			
25	G	T7W E29 716	TERMINAL BLOCK	6P (L,N,0,S1,S2,S3)	1		TB1	
26	G	—	ELECTRICAL PARTS BOX		1	(BK00B055G44)		
27	G	T7W E20 259	REACTOR		1		DCL	
28	G	T7W E81 315	CONTROLLER CIRCUIT BOARD		1		C.B.	
29	G	T7W E57 313	POWER CIRCUIT BOARD		1		P.B.	
30	G	R01 E06 239	FUSE	250V 6.3A	4		F1,2,3,4	
31	G	R01 H00 202	THERMISTOR (OUTDOOR PIPE)		1		TH3	
32	G	R01 E20 254	MAIN SMOOTHING CAPACITOR		1		CB	

**FUNCTIONAL AND ELECTRICAL PARTS
PUHZ-RP140YKA**

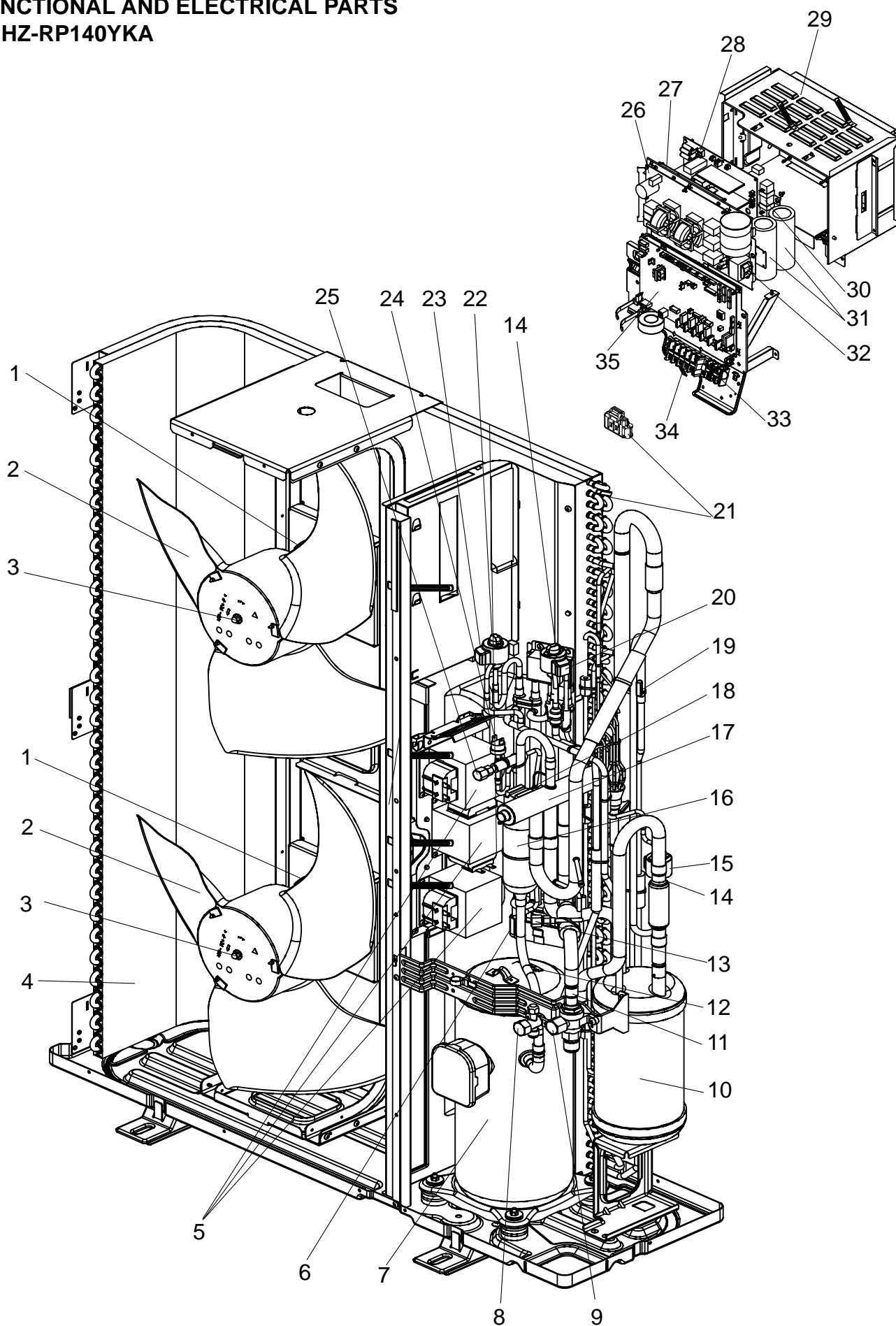

Part numbers that are circled are not shown in the figures.

No.	RoHS	Part No.	Part Name	Specification	Q'ty/set	Remarks (Drawing No.)	Wiring Diagram Symbol	Recom- mended Q'ty
					PUHZ-RP140YKA			
1	G	R01 E50 221	FAN MOTOR		2		MF1,2	
2	G	R01 E10 115	PROPELLER FAN		2			
3	G	R01 E09 097	NUT		2			
4	G	R01 H10 408	HEAT EXCHANGER		1			
5	G	T7W E12 259	REACTOR		3		ACL1,2,3	
6	G	T7W E04 201	THERMISTOR (DISCHARGE)		1		TH4	
7	G	T97 415 776	COMPRESSOR	ANB42FDXMT	1	With RUBBER MOUNTS	MC	
8	G	R01 E25 410	STOP VALVE	3/8	1			
9	G	R01 E12 410	BALL VALVE	5/8	1			
10	G	R01 E43 440	POWER RECEIVER		1			
11	G	R01 32L 450	STRAINER		1			
12	G	T7W E11 201	THERMISTOR (SHELL)		1		TH32	
13	G	R01 E24 413	CHARGE PLUG		1			
14	G	R01 H20 401	LEV		2			
15	G	R01 E50 242	LEV COIL		1		LEV(A)	
16	G	R01 E10 467	MUFFLER		1			
17	G	R01 E15 403	4-WAY VALVE		1			
18	G	T7W E41 242	SOLENOID COIL <4-WAY VALVE>		1		21S4	
19	G	T7W E52 202	THERMISTOR (OUTDOOR PIPE)		1		TH33	
20	G	R01 E49 242	LEV COIL		1		LEV(B)	
21	G	R01 H01 202	THERMISTOR (OUTDOOR 2PHASE PIPE, OUTDOOR)		1		TH6,7	
22	G	T7W E26 401	LEV		1			
23	G	R01 E68 242	LEV COIL		1		LEV(C)	
24	G	R01 E06 208	HIGH PRESSURE SWITCH		1		63H	
25	G	T7W E09 413	CHARGE PLUG		1			
26	G	T7W E23 346	NOISE FILTER CIRCUIT BOARD		1		N.F.	
27	G	T7W E75 310	CONVERTER CIRCUIT BOARD		1		CONV.B.	
28	G	T7W E58 313	POWER CIRCUIT BOARD		1		P.B.	
29	G	—	ELECTRICAL PARTS BOX		1	(BK00C410G09)		
30	G	R01 E10 233	RESISTOR		1		RS	
31	G	R01 E02 254	MAIN SMOOTHING CAPACITOR		2		CB1,CB2	
32	G	R01 E31 259	REACTOR		1		ACL4	
33	G	R01 E18 246	TERMINAL BLOCK	3P (S1,S2,S3)	1		TB2	
34	G	T7W E30 716	TERMINAL BLOCK	5P (L1,L2,L3,N,⊙)	1		TB1	
35	G	T7W E81 315	CONTROLLER CIRCUIT BOARD		1		C.B.	
36	G	R01 E06 239	FUSE	250V 6.3A	4		F1,2,3,4	
37	G	R01 H00 202	THERMISTOR (OUTDOOR PIPE)		1		TH3	
38	G	T7W E10 254	CAPACITOR		1		CK	

FUNCTIONAL AND ELECTRICAL PARTS
PUHZ-RP200YKA
PUHZ-RP250YKA

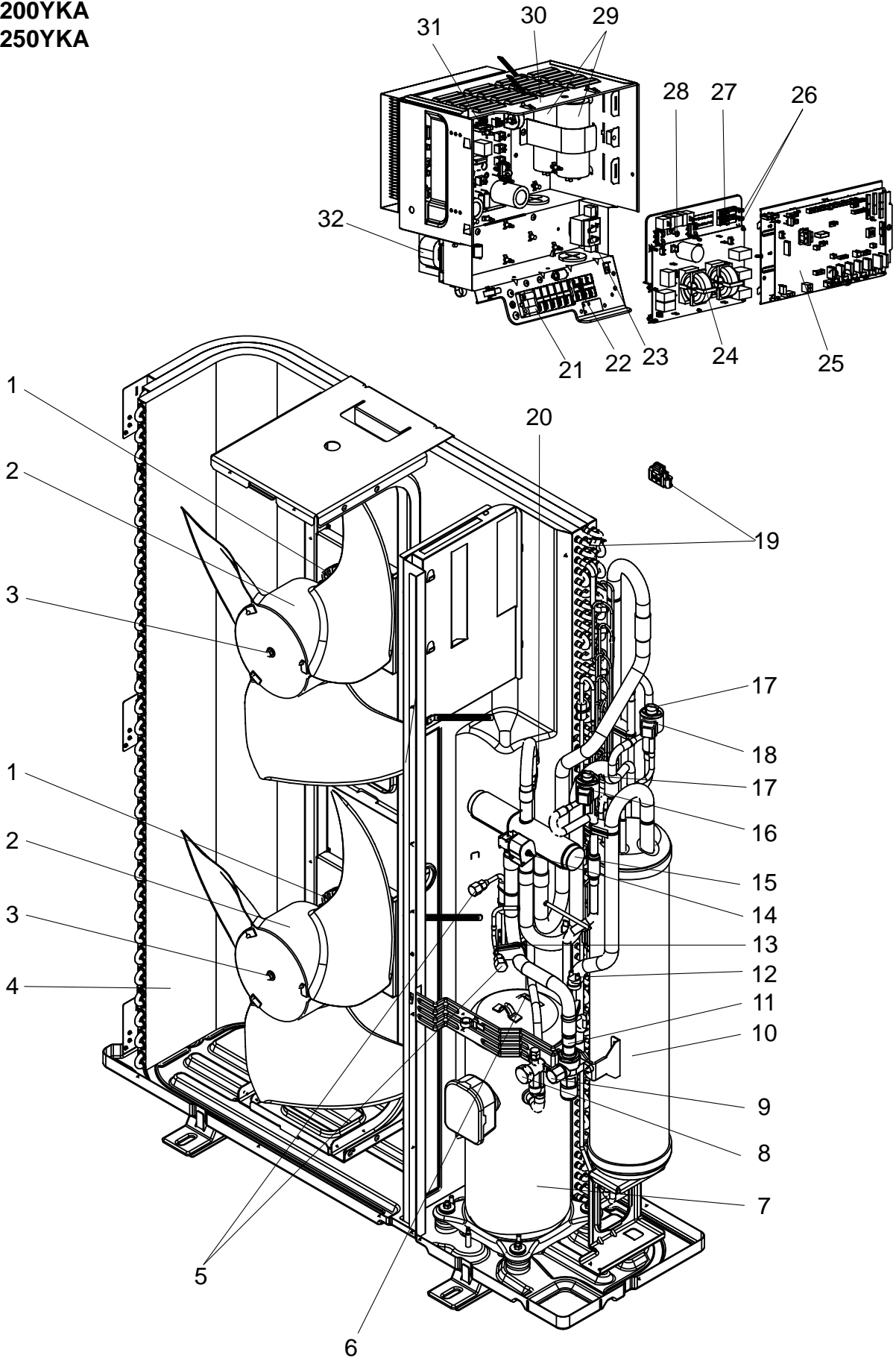

Part numbers that are circled are not shown in the figures.

No.	RCHS	Part No.	Part Name	Specification	Q'ty/set		Remarks (Drawing No.)	Wiring Diagram Symbol	Recom- mended Q'ty
					PUHZ-RP-YKA				
					200	250			
1	G	R01 H11 408	HEAT EXCHANGER		1	1			
2	G	R01 E46 221	FAN MOTOR		2	2		MF1,2	
3	G	R01 E10 115	PROPELLER FAN		2	2			
4	G	R01 E09 097	NUT	M6	2	2			
5	G	R01 E24 413	CHARGE PLUG		2	2			
6	G	T7W E11 201	SHELL THERMISTOR		1	1		TH32	
7	G	T97 415 770	COMPRESSOR	ANB52FFQMT	1		With RUBBER MOUNTS	MC	
	G	T97 415 777	COMPRESSOR	ANB66FFRMT		1	With RUBBER MOUNTS	MC	
8	G	R01 E25 410	STOP VALVE 3/8		1				
	G	R01 E23 410	STOP VALVE 1/2			1			
9	G	R01 E13 411	BALL VALVE 3/4		1	1			
10	G	T7W E19 440	POWER RECEIVER		1	1			
11	G	R01 45L 450	STRAINER		1	1			
12	G	T7W E06 208	HIGH PRESSURE SWITCH	OFF 3.6MPa		1		63H2	
13	G	T7W E04 201	THERMISTOR (DISCHARGE)		1	1		TH4	
14	G	T7W E53 242	SOLENOID COIL		1	1		21S4	
15	G	R01 E12 403	4-WAY VALVE		1	1			
16	G	T7W E54 242	LEV COIL		1	1		LEV-B	
17	G	R01 H27 401	LEV		2	2			
18	G	R01 E50 242	LEV COIL		1	1		LEV-A	
19	G	R01 N00 202	THERMISTOR (OUTDOOR 2PHASE PIPE, OUTDOOR)		1	1		TH6,7	
20	G	T7W E06 208	HIGH PRESSURE SWITCH	OFF 3.6MPa	1			63H	
	G	R01 E06 208	HIGH PRESSURE SWITCH	OFF 4.14MPa		1		63H1	
21	G	T7W E30 716	TERMINAL BLOCK	5P (L1,L2,L3,N,⊙)	1	1		TB1	
22	G	R01 E19 246	TERMINAL BLOCK	3P (S1,S2,S3)	1	1		TB2	
23	G	T7W E16 259	REACTOR		1	1		ACL4	
24	G	T7W E24 346	NOISE FILTER		1	1		N.F.	
25	G	T7W E82 315	CONTROLLER BOARD		1	1		C.B.	
26	G	R01 30L 241	FUSE HOLDER		2	2			
27	G	R01 E07 239	FUSE	250V 15A	2	2		FUSE1,2	
28	G	R01 E10 233	RESISTOR		1	1		RS	
29	G	R01 E02 254	MAIN SMOOTHING CAPACITOR		2	2		CB1,2	
30	G	—	ELECTRICAL PARTS BOX		1	1	(BK00B702G08)		
31	G	T7W E59 313	POWER BOARD		1	1		P.B.	
32	G	T7W E13 259	REACTOR		1	1		DCL	
33	G	R01 E96 202	THERMISTOR (OUTDOOR PIPE)		1	1		TH3	
34	G	R01 E06 239	FUSE	250V 6.3A	2	2		F3,4	
35	G	R01 E10 467	MUFFLER		1	1			

STRUCTURAL PARTS
PUHZ-RP35VHA4
PUHZ-RP50VHA4

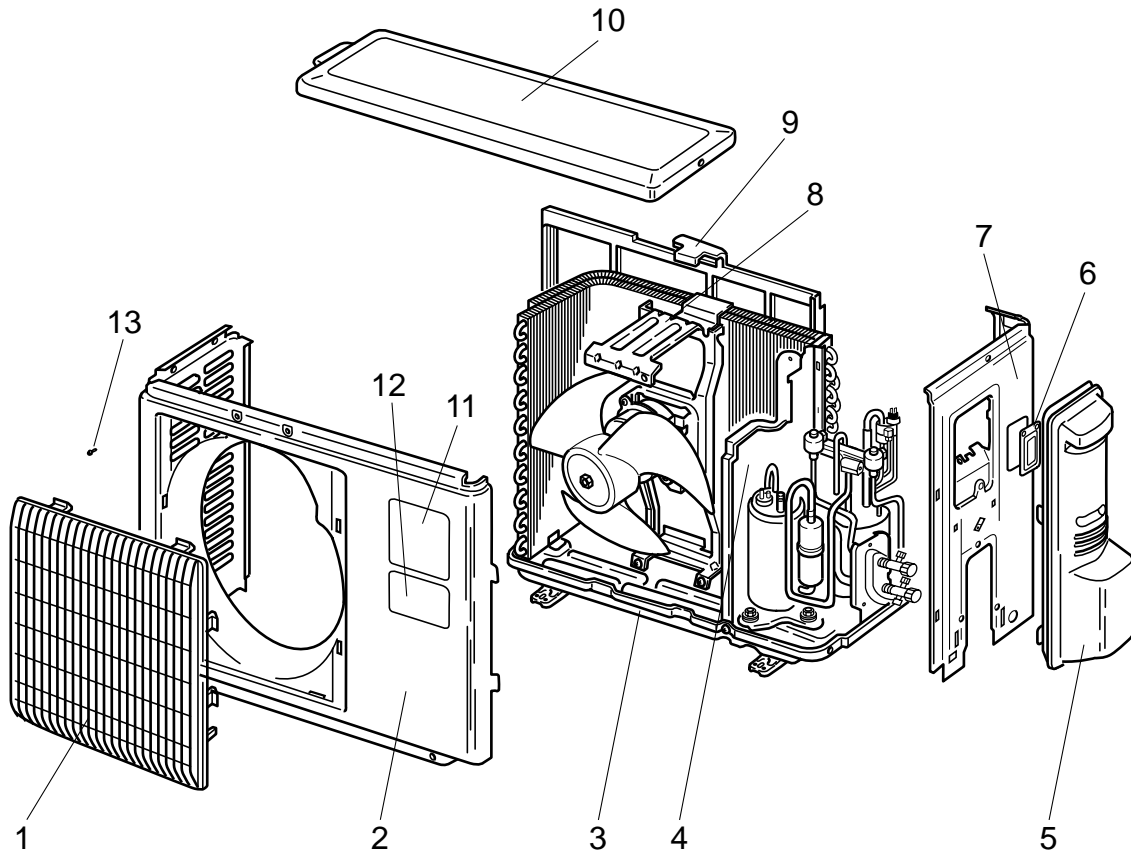

No.	RoHS	Part No.	Part Name	Specification	Q'ty/set		Remarks (Drawing No.)	Wiring Diagram Symbol	Recom- mended Q'ty
					PUHZ-RP35VHA4	PUHZ-RP50VHA4			
1	G	R01 E30 691	GRILLE			1			
2	G	R01 E09 668	FRONT PANEL			1			
3	G	R01 E29 686	BASE ASSY			1			
4	G	—	SEPARATOR			1	(SU00B229G37)		
5	G	T7W E12 668	SERVICE PANEL			1			
6	G	R01 E02 518	SERVICE PANEL			1			
7	G	R01 E06 682	BACK PANEL			1			
8	G	R01 E29 130	MOTOR SUPPORT			1			
9	G	R01 E02 684	CONDENSER NET			1			
10	G	T7W E05 641	TOP PANEL			1			
11	G	—	LABEL (MITSUBISHI)			1	(DG79R130H01)		
12	G	—	LABEL (INVERTER)			1	(BK79C208G02)		
13	G	—	F.ST SCREW	(4×10)		12	(Z504K189H37)		

STRUCTURAL PARTS
PUHZ-RP60VHA4
PUHZ-RP71VHA4

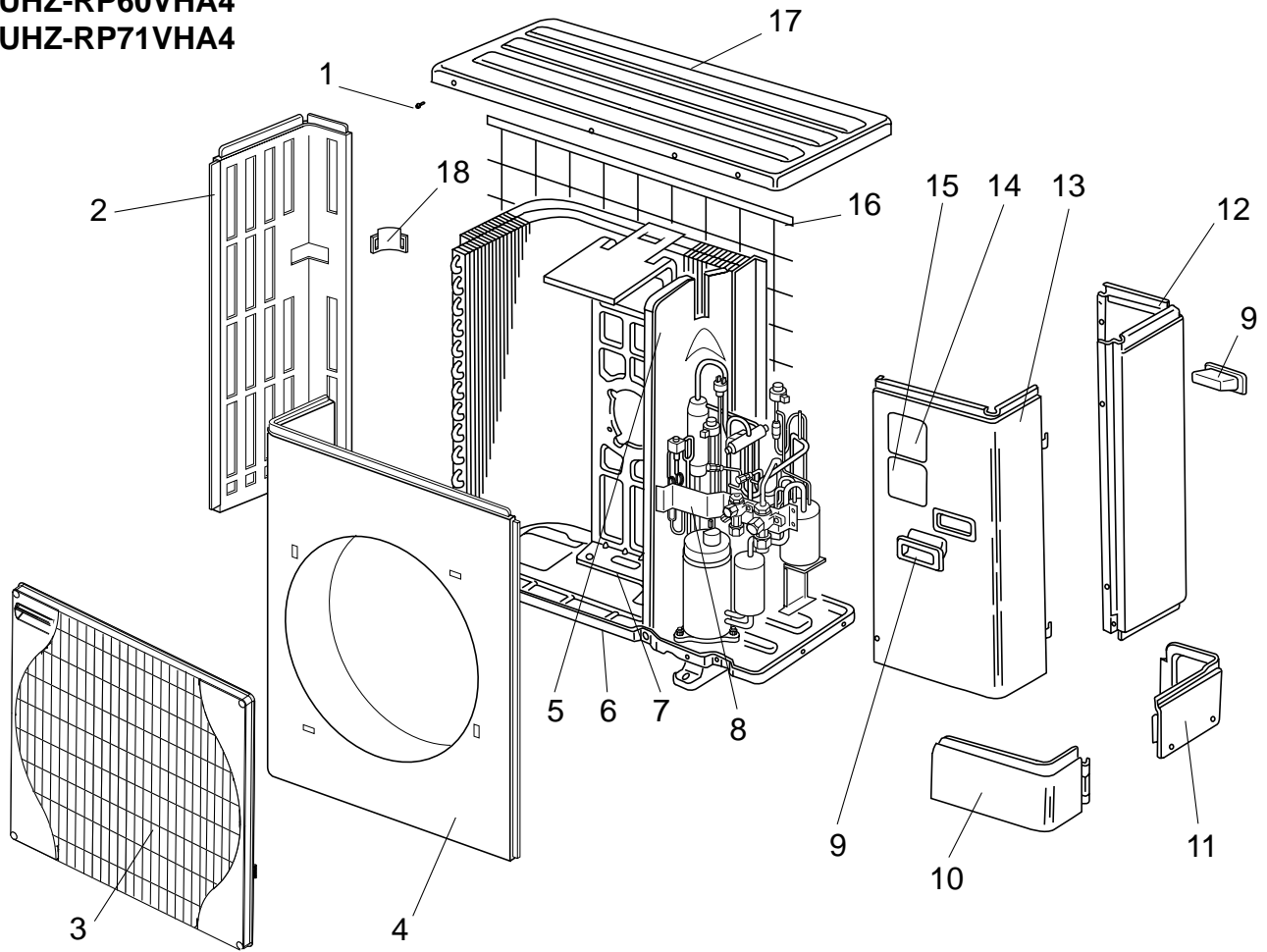

No.	RoHS	Part No.	Part Name	Specification	Q'ty/set		Remarks (Drawing No.)	Wiring Diagram Symbol	Recom- mended Q'ty
					PUHZ-RP60VHA4	PUHZ-RP71VHA4			
1	G	—	F.ST SCREW	(5x10)	31		(DG12F536H10)		
2	G	R01 E16 662	SIDE PANEL (L)		1				
3	G	R01 E33 691	FAN GRILLE		1				
4	G	R01 E13 668	FRONT PANEL		1				
5	G	—	SEPARATOR		1		(BK00C143GE2)		
6	G	R01 E32 686	BASE ASSY		1				
7	G	R01 E30 130	MOTOR SUPPORT		1				
8	G	—	VALVE BED ASSY		1		(BK00C375G06)		
9	G	R01 E01 655	HANDLE		2				
10	G	R01 E12 658	COVER PANEL (FRONT)		1				
11	G	R01 E11 658	COVER PANEL (REAR)		1				
12	G	R01 E46 661	SIDE PANEL (R)		1				
13	G	T7W E07 668	SERVICE PANEL		1				
14	G	—	LABEL (MITSUBISHI)		1		(DG79R130H01)		
15	G	—	LABEL (INVERTER)		1		(BK79C208G02)		
16	G	R01 E06 698	REAR GUARD		1				
17	G	R01 E14 641	TOP PANEL		1				
18	G	R01 E02 655	HANDLE		1				

STRUCTURAL PARTS

- PUHZ-RP100VKA
- PUHZ-RP125VKA
- PUHZ-RP140VKA
- PUHZ-RP100YKA
- PUHZ-RP125YKA
- PUHZ-RP140YKA
- PUHZ-RP200YKA
- PUHZ-RP250YKA

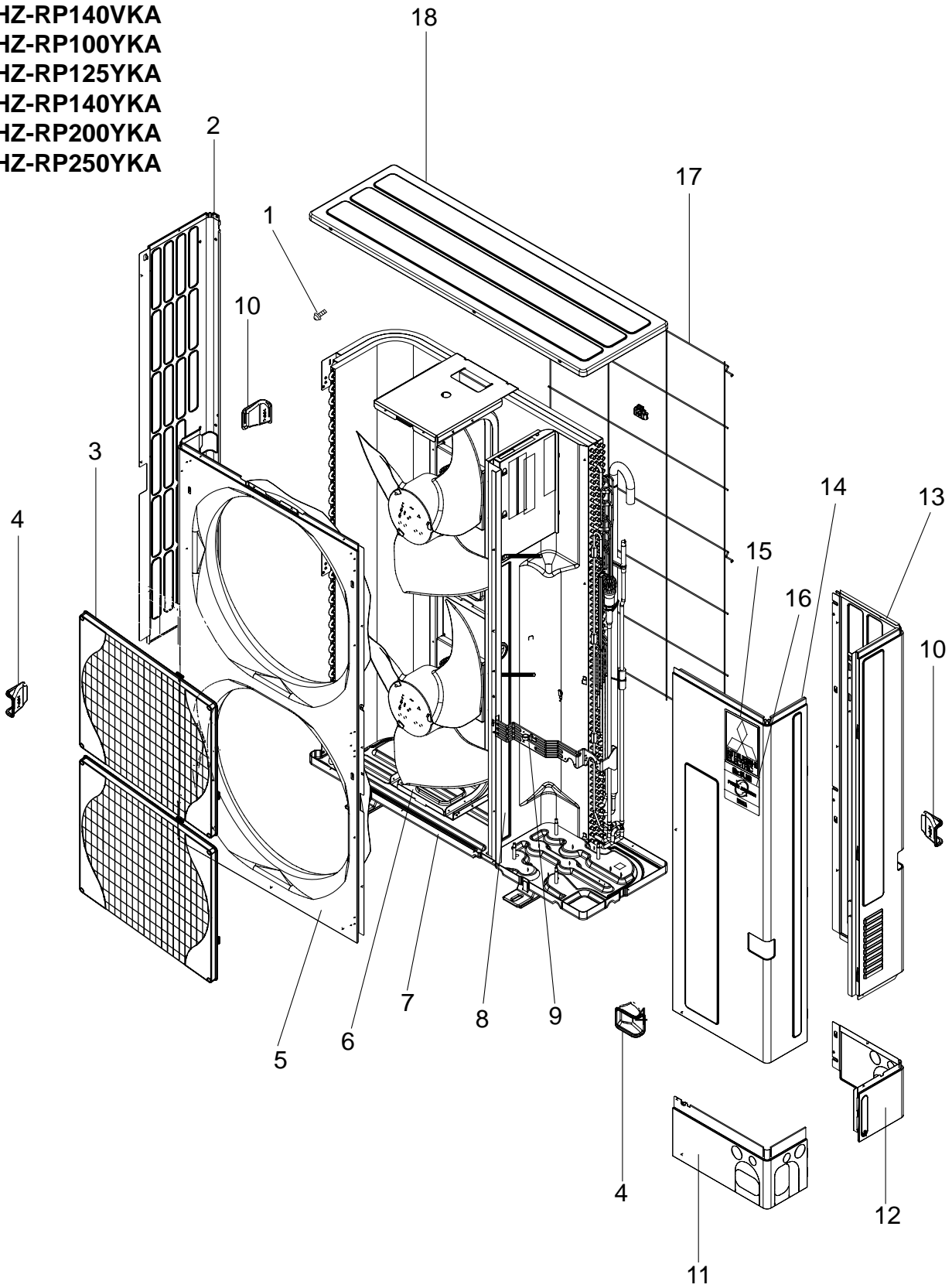



No.	RoHS	Part No.	Part Name	Specifi- cation	Q'ty/set						Remarks (Drawing No.)	Wiring Diagram Symbol	Recom- mended Q'ty
					PUHZ-RP-KA								
					100/ 125V	140V	100/ 125Y	140Y	200Y	250Y			
1	G	—	F.ST SCREW	(5x10)	37	37	37	37	37	37	(DG12F536H10)		
2	G	R01 E29 662	SIDE PANEL (L)		1	1	1	1	1	1			
3	G	T7W E08 691	FAN GRILLE		2	2	2	2	2	2			
4	G	R01 E04 655	HANDLE		2	2	2	2	2	2			
5	G	T7W E13 667	FRONT PANEL		1	1	1	1	1	1			
6	G	R01 E42 130	MOTOR SUPPORT		1	1	1	1					
	G	R01 E43 130	MOTOR SUPPORT						1	1			
7	G	R01 E41 686	BASE ASSY		1	1	1	1	1	1			
8	G	—	SEPARATOR		1						(BK00B817G52)		
	G	—	SEPARATOR			1					(BK00B817G53)		
	G	—	SEPARATOR				1				(BK00B817G55)		
	G	—	SEPARATOR					1			(BK00B817G56)		
	G	—	SEPARATOR						1	1	(BK00B817G54)		
9	G	—	VALVE BED ASSY		1	1	1	1	1	1	(BK00C375G07)		
10	G	R01 E03 655	HANDLE		2	2	2	2	2	2			
11	G	T7W E13 658	COVER PANEL (FRONT)		1	1	1	1		1			
	G	R01 E28 658	COVER PANEL (FRONT)						1				
12	G	R01 E27 658	COVER PANEL (REAR)		1	1	1	1	1				
	G	T7W E12 658	COVER PANEL (REAR)							1			
13	G	R01 E49 661	SIDE PANEL (R)		1	1							
	G	T7W E28 661	SIDE PANEL (R)				1	1					
	G	T7W E29 661	SIDE PANEL (R)						1	1			
14	G	T7W E15 668	SERVICE PANEL		1	1	1	1	1	1			
15	G	—	LABEL (MITSUBISHI)		1	1	1	1	1	1	(DG79R130H01)		
16	G	—	LABEL (INVERTER)		1	1	1	1	1	1	(BK79C208G02)		
17	G	R01 E10 698	REAR GUARD		1	1	1	1	1	1			
18	G	R01 E30 641	TOP PANEL		1	1	1	1	1	1			

Mr. SLIM™

 **mitsubishi electric corporation**

HEAD OFFICE : TOKYO BLDG., 2-7-3, MARUNOUCHI, CHIYODA-KU, TOKYO 100-8310, JAPAN